



PRONAR SP. Z O.O.

17-210 NAREW, UL. MICKIEWICZA 101A, WOJ. PODLASKIE

TEL.: +48 085 681 63 29

+48 085 681 64 29

+48 085 681 63 81

+48 085 681 63 82

FAX: +48 085 681 63 83

+48 085 682 71 10

USER MANUAL

SEPTIC TANKER

PRONAR TG214

TRANSLATION OF THE ORIGINAL MANUAL

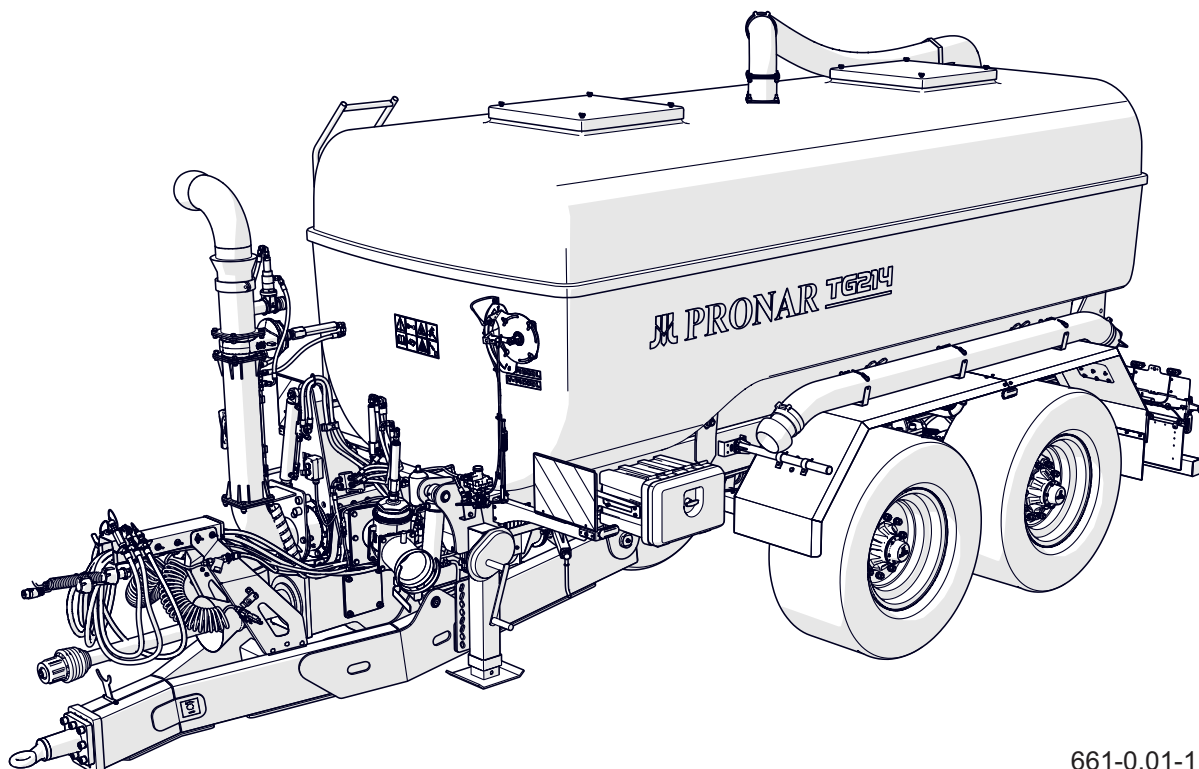

661-0.01-1

ISSUE 1A

11-2021

EDITION NO. 661.01.UM.1A.EN

EN

Manufacturer's address

*PRONAR Sp. z o.o.
ul. Mickiewicza 101A
17-210 Narew*

Contact phones

*+48 085 681 63 29
+48 085 681 64 29
+48 085 681 63 81
+48 085 681 63 82*

Website

*www.pronar.pl
<https://pronar-recycling.com/pl/>*

Service hotline

*+48 085 682 71 14
+48 085 682 71 93
+48 085 682 71 20
serwis@pronar.pl*

This manual contains important safety and operating instructions for the machine. The manual should be kept near the machine so that it is accessible to persons authorized to operate it.

Keep this manual for future reference. If the manual is lost or damaged, contact the seller or the manufacturer for a duplicate.

Copyright © PRONAR Sp. z o.o. All rights reserved.

This study is the property of PRONAR Sp. z o.o. and is a work within the meaning of the Copyright and Related Rights Act.

Any part of this document may not be distributed or copied in any way (electronic, mechanical or otherwise) without the written consent of PRONAR Sp. z o.o.

Table of contents

| | |
|---|------------|
| CHAPTER 1 | |
| INTRODUCTION | 1.1 |
| 1.1 Dear User | 1.2 |
| 1.2 Rules for using the User's Manual | 1.4 |
| 1.3 Target group | 1.5 |
| 1.3.1 End user (User, Authorized User, Operator) | 1.5 |
| 1.3.2 Qualified person (qualified personnel) | 1.6 |
| 1.3.3 Service personnel | 1.6 |
| 1.3.4 Unauthorized user | 1.7 |
| 1.4 Symbols and tags used in the manual | 1.8 |
| 1.4.1 Danger | 1.8 |
| 1.4.2 Caution | 1.8 |
| 1.4.3 Advice | 1.8 |
| 1.4.4 Personal protective equipment pictograms | 1.9 |
| 1.4.5 Qualification pictograms | 1.9 |
| 1.4.6 Typography of the User Manual | 1.10 |
| 1.5 Glossary | 1.12 |
| 1.6 Definition of directions in the manual | 1.14 |
| 1.7 Final acceptance | 1.15 |
| 1.7.1 Preliminary information | 1.15 |
| 1.7.2 Checking the machine after delivery | 1.15 |
| 1.7.3 The first start of the machine | 1.16 |
| 1.8 Environmental hazard | 1.18 |
| CHAPTER 2 | |
| BASIC INFORMATION | 2.1 |
| 2.1 Identification | 2.2 |
| 2.1.1 Machine identification | 2.2 |
| 2.1.2 Identification of the driving axle | 2.5 |
| 2.2 Intended use of the machine | 2.6 |
| 2.2.1 Using the machine in accordance with intended use | 2.6 |
| 2.2.2 Expected misuse | 2.7 |
| 2.3 Agricultural tractor requirements | 2.9 |
| 2.3.1 Minimum load on the front axle of the tractor | 2.9 |
| 2.4 Machine equipment | 2.11 |
| 2.5 Transport | 2.12 |
| 2.5.1 Trucking | 2.12 |
| 2.5.2 Own transport | 2.13 |

| | | |
|-----|-------------------------|------|
| 2.6 | Terms of warranty..... | 2.15 |
| 2.7 | Environmental risk..... | 2.16 |
| 2.8 | Withdrawal..... | 2.17 |

CHAPTER 3

SAFETY OF USE..... 3.1

| | | |
|-----|--|------|
| 3.1 | Basic safety rules..... | 3.2 |
| 3.2 | Safety during coupling of the machine..... | 3.4 |
| 3.3 | Safety when operating the hydraulic and pneumatic systems..... | 3.6 |
| 3.4 | Principles of safe maintenance..... | 3.8 |
| 3.5 | Description of residual risk..... | 3.11 |
| 3.6 | Driving on public roads..... | 3.12 |
| 3.7 | Working with the machine with the power take-off (PTO)..... | 3.15 |
| 3.8 | Information and warning stickers..... | 3.17 |

CHAPTER 4

DESIGN AND OPERATION..... 4.1

| | | |
|-------|--|------|
| 4.1 | Technical specifications..... | 4.2 |
| 4.2 | Machine construction..... | 4.4 |
| 4.3 | Pneumatic brake system..... | 4.6 |
| 4.4 | Parking brake..... | 4.9 |
| 4.5 | Tank..... | 4.10 |
| 4.6 | Hydraulic drawbar system..... | 4.11 |
| 4.7 | Liquid distribution system..... | 4.12 |
| 4.7.1 | Construction of the pumping system..... | 4.12 |
| 4.7.2 | Hydraulic liquid distribution system..... | 4.13 |
| 4.8 | Docking mechanism..... | 4.15 |
| 4.8.1 | Construction of the docking mechanism..... | 4.15 |
| 4.8.2 | Hydraulic system of the docking mechanism..... | 4.16 |
| 4.9 | Rear hydraulic outlets..... | 4.18 |
| 4.10 | Hydraulic steering lock system..... | 4.19 |
| 4.11 | Electrical lighting installation..... | 4.20 |

CHAPTER 5

CORRECT USE..... 5.1

| | | |
|-------|---|------|
| 5.1 | Height adjustment of the drawbar..... | 5.2 |
| 5.2 | Handling of the parking stand..... | 5.4 |
| 5.3 | Coupling and uncoupling of the machine..... | 5.6 |
| 5.3.1 | Coupling of the machine..... | 5.6 |
| 5.3.2 | Disconnecting of the trailer..... | 5.11 |
| 5.4 | Loading..... | 5.12 |

| | |
|---|------|
| 5.4.1 Loading via suction connection (left or right)..... | 5.12 |
| 5.4.2 Loading via docking system (left or right)..... | 5.14 |
| 5.5 Transport..... | 5.17 |
| 5.6 Unloading..... | 5.20 |
| 5.7 Feed pump..... | 5.22 |
| 5.8 Rules for the use of tires..... | 5.23 |
| 5.9 Cleaning..... | 5.25 |
| 5.10 Storage..... | 5.27 |

CHAPTER 6

| | |
|---|------|
| PERIODIC INSPECTIONS AND THE TECHNICAL SUPPORT..... | 6.1 |
| 6.1 General..... | 6.2 |
| 6.2 High-risk places..... | 6.3 |
| 6.3 Maintenance and inspection schedule..... | 6.4 |
| 6.4 Preparing of the trailer..... | 6.7 |
| 6.5 Air tank drainage..... | 6.9 |
| 6.6 Guard inspection..... | 6.10 |
| 6.7 Checking plugs and connection sockets..... | 6.12 |
| 6.8 Machine check before starting to drive..... | 6.14 |
| 6.9 Air pressure measurement, tire and rim inspection..... | 6.16 |
| 6.10 Inspection and cleaning of the delivery pump..... | 6.18 |
| 6.11 Cleaning the air filters..... | 6.20 |
| 6.12 Cleaning the drainage valve..... | 6.21 |
| 6.13 Checking brake lining wear..... | 6.22 |
| 6.14 Checking of the clearance of the axle bearings..... | 6.23 |
| 6.15 Checking of mechanical brakes..... | 6.25 |
| 6.16 Adjusting of the parking brake cable tension..... | 7.27 |
| 6.17 Hydraulic system Checking..... | 6.29 |
| 6.18 The pneumatic braking system inspection..... | 6.31 |
| 6.19 Tightening torques for screw connections..... | 6.32 |
| 6.20 Tightening road wheels..... | 6.34 |
| 6.21 Replacement of hydraulic hoses..... | 6.36 |
| 6.22 Boogie suspension control..... | 6.37 |
| 6.23 Adjustment of the clearance of wheel axle bearings..... | 6.40 |
| 6.24 Brake adjustment..... | 6.42 |
| 6.25 Lubrication..... | 6.47 |
| 6.26 Maintenance of electrical installation and warning elements..... | 6.51 |
| 6.27 Consumables..... | 6.52 |
| 6.27.1 Hydraulic oil..... | 6.52 |
| 6.27.2 Lubricants..... | 6.53 |
| 6.28 Tires..... | 6.54 |

| | |
|---|------|
| 6.29 Faults and methods to remove them..... | 6.55 |
| CHAPTER 7 | |
| CONTROL PANEL..... | 7.1 |
| 7.1 Control system..... | 7.2 |
| 7.1.1 Main control pilot..... | 7.3 |
| 7.1.2 Additional remote control..... | 7.3 |
| 7.1.3 Inductive sensors..... | 7.5 |
| CHAPTER 8 | |
| ATTACHMENTS AND ADDITIONAL MATERIALS..... | 8.1 |



PRONAR Sp. z o.o.
ul. Mickiewicza 101 A
17-210 Narew, Polska
tel./fax (+48 85) 681 71 00,
fax (+48 85) 681 63 83
<http://www.pronar.pl>
e-mail: pronar@pronar.pl

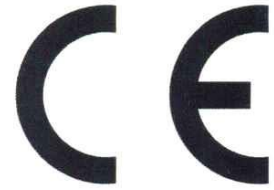

EC Declaration of Conformity

PRONAR Sp. z o.o. declares, with full responsibility, that the machine:

| Machine description and identification data | |
|---|---|
| General description and purpose: | SLURRY TANKER |
| Type: | TG01 |
| Model: | TG214 |
| VIN number: | |
| Commercial name: | TG214 or PRONAR TG214 or slurry tanker TG214 or slurry tanker PRONAR TG214 |

referred to in this declaration meets the requirements of the Directive **2006/42/EC** of The European Parliament and of The Council of 17 May 2006 on machinery.

The machine has been designed for and meets the requirements of the following standards:

PN-EN ISO 12100:2012, PN-EN 707:2019-03

This declaration applies exclusively to the machine in the condition, in which it was sold and does not include components or parts added or subsequent modifications made by the final user.

The operator's manual is an integral part of the machine.

The Implementation Department Manager of PRONAR Sp. z o.o., 17-210 Narew, ul. Mickiewicza 101A is authorised to provide the technical documentation.

Narew, on 2022-03-31
Date and place issued

PRONAR Spółka z o.o.
17- 10 Narew ul. Mickiewicza 101A
Tel. (85) 681 63 29 , 682 72 54
Fax: (85) 681 63 83
NIP 517-02-09-939, KRS 000139188
000700014169

OSOBA DYREKTORA
d/s technicznych
działań zarządu

Dominik Dzielniuk

Full name of the authorised person,
position, signature

Chapter 1

Introduction

PRONAR TG214

1.1 DEAR USER

The manual instruction is intended for the end user. For this reason, some required maintenance is listed in the inspection tables but the procedure is not described in this publication. To perform them, call the manufacturer's authorized service center.

Before starting the machine, you will be familiarized with its construction, principle of operation, available equipment and operation, and above all safety rules. The operator and qualified personnel should be trained during final reception.

Remember!!! You can run the machine only when you have read the content of this „User Manual”, you have been trained and you can handle it safely. In case of any doubts, contact the seller to clarify the problem.

The most important thing during operation is your safety, therefore, regardless of everything, all recommendations

contained in the „User's Manual” should be observed and guided by reasonable procedure.

Remember that the correct service, in accordance with the manufacturer's instructions, reduces the risk of an accident to a minimum, and working with the machine is more efficient and less emergency.

When buying machines, check the compatibility of serial numbers placed on the machine with the number entered in the “Warranty card” and in the sales documents. For information on identifying the machine, see “Basic information” chapter. We recommend that you have the most important serial numbers entered the field below.

Machine serial number:

| | | | | | | | | | | | | | | | | |
|--|--|--|--|--|--|--|--|--|--|--|--|--|--|--|--|--|
| | | | | | | | | | | | | | | | | |
|--|--|--|--|--|--|--|--|--|--|--|--|--|--|--|--|--|

WST.3.B-001.01.EN

1.2 RULES FOR USING THE USER'S MANUAL

The information contained in the publication is current as at the date of publication. As a result of improvement, some sizes and illustrations contained in this publication may not correspond to the actual state of the machine delivered to the user.

The drawings contained in this publication are aimed at clarifying the principle of machine operation and may differ from the facts. This can not be a reason for any claims for this. The manufacturer reserves the right to introduce constructional changes in the manufactured machines to facilitate operation and improve the quality of their work, without making any current changes to this publication.

The operating instruction is the basic equipment of the machine. If the information contained in this study prove not fully understandable to ask for aid to the point of sale in which the machine has been purchased or directly to the manufacturer.

The machine was constructed in accordance with applicable standards, documents and current legal regulations.

Separate studies can be attached to this manual that can be found in the chapter "*Attachments and additional materials*".

WST.3.B-002.01.EN

1.3 TARGET GROUP

The User Manual is intended for staff operating the machine called end users, and qualified persons (electrician, mechanic, plumber). Detailed information on the competences and liability of end users and qualified personnel can be found later in this chapter.

1.3.1 End user (User, Authorized User, Operator)

Who is the end user?

An end user, otherwise known as the user or operator, call the person authorized to operate the machine. The user can be authorized to handle the machine if the following conditions have been met.

- The user has familiarized with the content of the "User's Manual".
- He gets acquainted with the contents of the farm tractor instruction manual and observes its recommendations.
- He complies with road traffic regulations and transport regulations in force in the country in which the machine is used,
- He has been trained in terms of compliance with established maintenance and regulation plans.
- He has authorizations to drive vehicles (vehicle assemblies) required in the country of use.

Responsibilities and permissions

The user acquired by the user allows for safe handling of the machine. In unforeseen cases, the user should follow a reasonable procedure and take care of their safety, people located near a working machine and other traffic users.

The knowledge and skills are entitled to the end user to handle the machine, carry out maintenance and repair or adjustment procedures in the scope specified by the manufacturer.

1.3.2 Qualified person (qualified personnel)

Who is a qualified person?

We call a qualified person any person admitted to perform some maintenance, repair or regulatory work in the scope specified by the machine manufacturer and who gained appropriate technical education in a specific profession and confirmed by the relevant document, completed the training carried out by the authorized manufacturer's or seller staff, can see threats and counteract them. Professional experience and professional skills entitle a qualified person to carry out some repairs of the machine and perform basic maintenance procedures in the scope provided by the manufacturer. A qualified person in addition to the necessary knowledge has the skills to use the specialized accessories necessary to perform the obligations. The following persons include qualified persons:

- Qualified mechanic.
- Qualified electrician.
- Qualified plumber.

1.3.3 Service personnel

Who is the service personnel?

Service personnel, otherwise known as the manufacturer's service or service, is a person or a group of qualified persons who have a much greater experience and knowledge to perform certain corrective and maintenance activities than qualified personnel. It has the right tools necessary to carry out work. The manufacturer's service has the required permissions

and is a representative of a machine manufacturer or other equipment.

1.3.4 Unauthorized user

Who is an unauthorized user?

An unauthorized user also known as a bystander is a person who has not been trained by the manufacturer or an authorized seller, has not been familiarized with the basic issues of security, knowledge of the machine, did not familiarize with the entire content of the operating instructions, and therefore there are no authorizations to operate the machine. A bystander can not be admitted to work with the machine.

WST.3.B-003.01.EN

1.4 SYMBOLS AND TAGS USED IN THE MANUAL

1.4.1 Danger

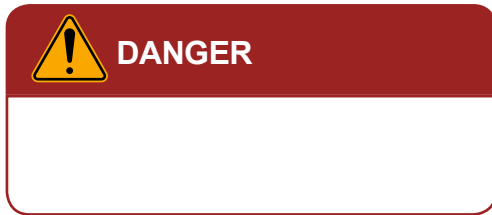

Information, descriptions of hazards and precautions as well as instructions and orders related to the safety of use in the content of the manual are marked with a frame with the word **DANGER**. Failure to comply with these recommendations may endanger the health or life of persons operating the machine or bystanders.

1.4.2 Caution

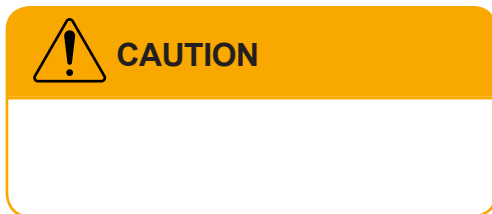









Particularly important information and recommendations, the observance of which is absolutely necessary, are highlighted in the text with a frame and word **CAUTION**. Failure to comply with these recommendations creates the risk of damage to the machine due to improper handling, adjustment or use.

1.4.3 Advice







Additional instructions contained in the manual describe useful information on operating the machine and are marked with a frame with the word **ADVICE**.

1.4.4 Personal protective equipment pictograms

| | |
|---|------------------------|
|  | Work shoes |
|  | reflective vest |
|  | industrial helmet |
|  | working clothes |
|  | respiratory protection |
|  | safety goggles |
|  | protective gloves |
|  | hearing protectors |

1.4.5 Qualification pictograms

| | |
|---|-----------------------|
|  | operator |
|  | qualified mechanic |
|  | qualified plumber |
|  | qualified electrician |

1.4.6 Typography of the User Manual

Bulleted list

The bulleted list presents actions to perform whose order is not relevant.

Example of using a bulleted list

-
- Check the condition of connections and hydraulic and pneumatic hoses. Hydraulic oil leaks and air defects from a leaky installation are unacceptable.
- In the event of a hydraulic or pneumatic installation failure, the trailer should be turned off from operation until the failure is removed.
-

Comment on the text

Comment is most often a supplement and additional explanation to order a specific activity. Additional information can also be included in the comment.

An example of a comment

The required air pressure is described on the sticker placed on the machine frame, over the wheel.

Defined list

List shows the to-do, which execution order is important.

Example of using a defined list

1.
2. Unscrew the handles (2) securing the crank (1).
3. Insert the crank into a square shaft of the gear and turning the clock clockwise on the direction of the clock.
4.

References to pages

Reference to chapter (place in the manual) related thematically

An example of a reference application

 **page 9.4**

WST.3.B-004.02.EN

1.5 GLOSSARY

Agricultural tractor

A motor vehicle constructed for use in conjunction with equipment for agricultural, forestry or horticultural work; such a tractor may also be adapted for pulling trailers and for earthworks.

Truck tractor

A motor vehicle designed exclusively for towing a trailer; the term includes a semi-trailer tractor and a ballast tractor.

Load capacity

A motor vehicle made in a special way so that it not only pulls the tools but also carries them on itself, it can work with attachable or hanging tools at the rear or front of the vehicle.

Final acceptance

The set of activities involved in the preparation and actual handover of the finished product for use. The final acceptance includes the handover of documentation, basic training, acceptance under transport and the first commissioning of the machine.

Bystander

see - unauthorised user

qualified person

A person who is authorised to carry out certain maintenance, repair or adjustment work within the scope defined by the manufacturer of the machine and who has acquired the relevant technical training in the specified profession and confirmed by a relevant document, has completed training provided

by authorised personnel of the manufacturer or the dealer, and is able to recognise and prevent risks.

Truck

A motor vehicle designed for the carriage of goods; the term also includes a lorry designed for the carriage of goods and passengers between 4 and 9 including the driver.

Danger zone

A danger zone is a designated area around a machine in which people are at risk of losing their health or life.

TPL

TPL - Three-point linkage - a lever system used on agricultural tractors for the aggregation of machinery and equipment suspended from a hydraulic linkage.

end user

Otherwise known as the user, authorised user or operator is the person permitted to operate the machine.

Unauthorised user

Also referred to as a bystander, this is a person who has not been trained and allowed to operate the machine.

PTO

PTO - Power take-off - the shaft that transmits drive from the vehicle to the machine being moved.

ALB

Automatic load-dependent brake force regulator, or ALB. (Automatischer Lastabhängiger Bremskraftregler).

1.6 DEFINITION OF DIRECTIONS IN THE MANUAL

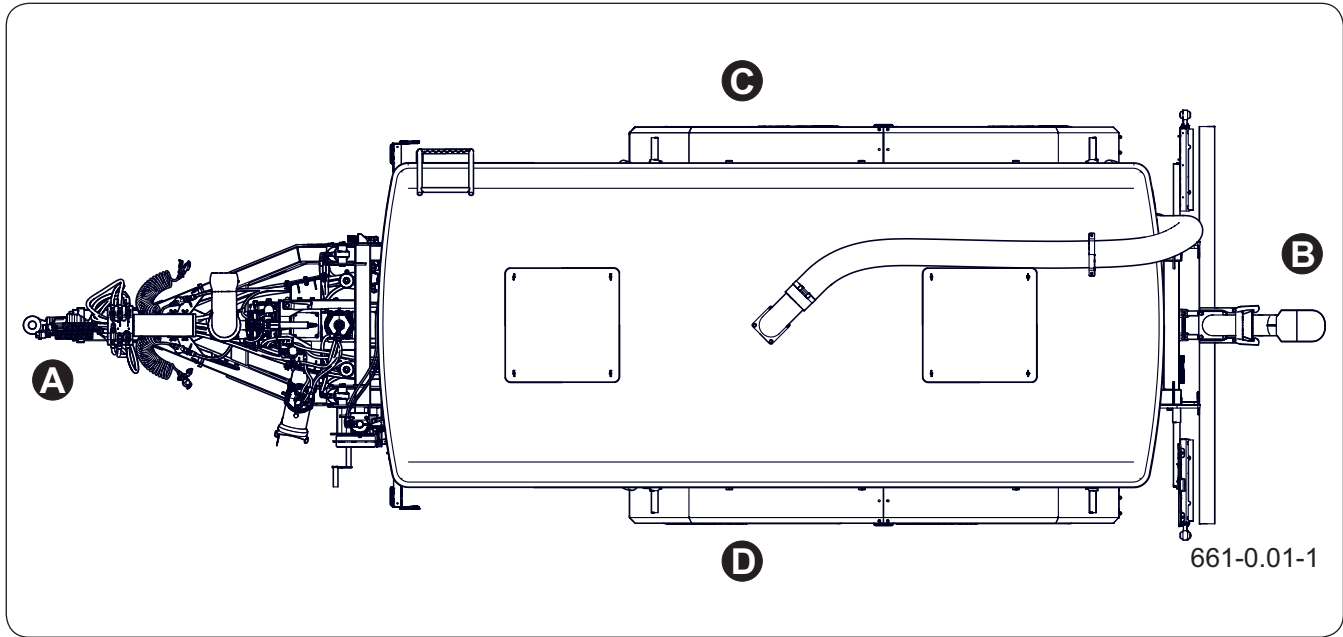

Figure 1.1 Definition of directions on the machine

(A) front

(B) rear

(C) right side

(D) left side

Left side - the side on the left hand of the observer facing the forward direction of the machine.

Right side - the side to the right of the observer facing the forward direction of the machine.

Right-hand rotation - clockwise rotation of the mechanism (operator facing the mechanism).

Left-hand rotation - counterclockwise rotation of the mechanism (operator facing the mechanism).

WST.3.B-006.01.EN

1.7 FINAL ACCEPTANCE

1.7.1 Preliminary information

Final acceptance takes place after the machine has been delivered. The acceptance covers the following issues:

- providing the required documents, including the "User Manual", "Warranty Card" and others,
- information from the seller about the method of use, hazards resulting from using the machine contrary to its intended use and about aggregating the machine with a tractor and working with it.
- checking the machine after delivery,
- first start-up of the machine and discussion of machine operation.

1.7.2 Checking the machine after delivery

The scope of control

- Check the completion of the machine in accordance with the order.
- Check technical condition of guards.
- Check the condition of the paint coating, check for any signs of corrosion.
- Check the machine for missing parts or damage resulting from incorrect transport of the machine to its destination point (dents, punctures, bends or broken parts, etc.).
- Check the condition of the tires on the road wheels and the air pressure in the tires. Check the correct tightening of the wheels.
- Check the technical condition of flexible conduits of the hydraulic and pneumatic systems. Make sure the layouts are tight.
- Inspect the hydraulic and/or pneumatic

cylinders for leaks and leaks.

1.7.3 The first start of the machine

The start-up must be preceded by training conducted by the Seller or authorized employees of the Seller.

The scope of activities for the first start-up

- Make sure that the pneumatic, hydraulic and electrical connections on the agricultural tractor comply with the manufacturer's requirements.
- Check all lubrication points, re lubricate if necessary.
- Drain the air reservoir the brake system.

If the condition of the machine does not raise any objections, go to the test drive:

- Connect the machine to the tractor hitch.
- Connect the pneumatic, hydraulic and electrical conduits.
- By activating the individual lights, check the correct operation of the electrical system.
- Control the correct operation of the hydraulic system by controlling the appropriate circuits of the tractor's hydraulic distributor.

Optionally, start the PTO and check the operation of the hydraulic system of the machine driven by the tractor's PTO shaft.

- Apply the brake.
- While moving off, check the operation of the main brake system.
- Release the tractor parking brake.

If during the test run, alarming symptoms appear, such as:

- Noise and unnatural sounds coming from the rubbing of moving parts against the machine structure,
- Leaking braking system,
- hydraulic oil leaks,

- Incorrect operation of hydraulic and/or pneumatic actuators,

or other faults, diagnose the problem. If the fault cannot be repaired or repairing it may void the warranty, contact the point of sale to explain the problem or make repairs.

After completing the test run, check the tightness of the wheel nuts.

WST.3.B-007.01.EN

1.8 ENVIRONMENTAL HAZARD



DANGER

Used oil or collected residues mixed with absorbent material should be stored in an accurately marked container. Do not use food packaging for this purpose.



CAUTION

Oil waste may only be delivered to a point dealing with the utilization or regeneration of oils. Under no circumstances should oils be poured into drains or water bodies.

A leakage of hydraulic, lubricating or diesel oil is a direct threat to the natural environment due to the limited biodegradability of the substance.

When carrying out maintenance and repair works where there is a risk of leakage, perform these works in rooms with an oil-resistant surface. In the event of a substance leak into the environment, first secure the source of the leak, and then collect the spilled substance using available means. Collect the remaining oil with sorbents or mix with sand, sawdust or other absorbent materials. The collected contaminants should be stored in a sealed and marked container, resistant to hydrocarbons, and then transferred to a disposal point. The container should be kept away from heat sources, flammable materials and food.

Used oils or oils that cannot be reused due to the loss of their properties are recommended to be stored in their original packaging in the same conditions as described above.

WST.3.B-008.01.EN

Chapter 2

Basic information

PRONAR TG214

2.1 IDENTIFICATION

2.1.1 Machine identification

ADVICE

You should require the seller to carefully fill out the Warranty Card and complaint coupons. The lack of e.g. date of sale or point of sale stamp exposes the user to not accept any complaints.

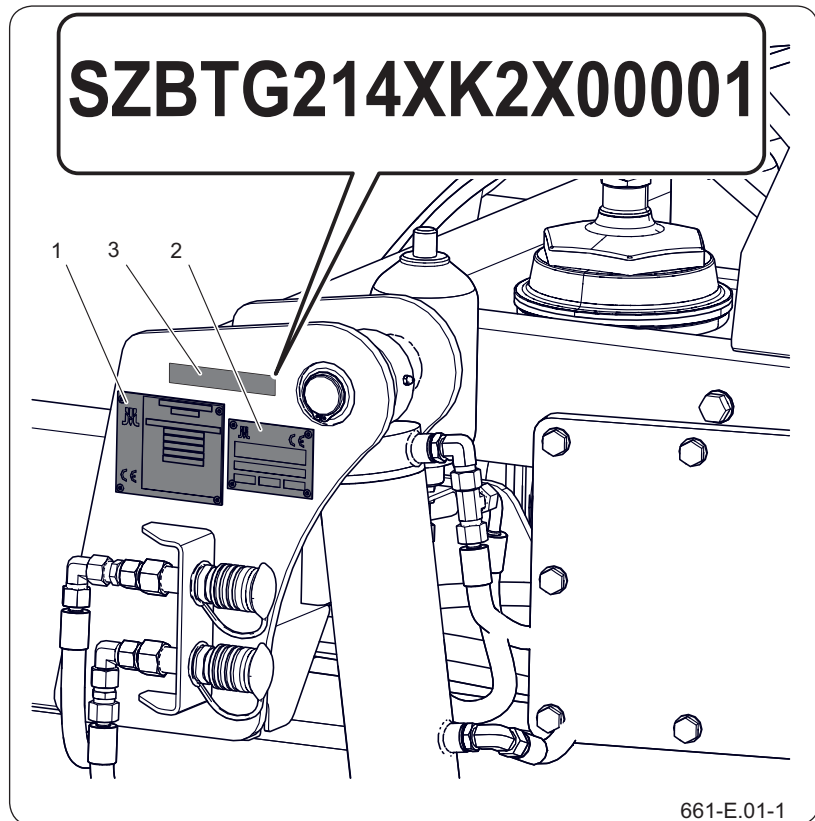

Figure 2.1 Machine identification

- (1) Nameplate (2) CE plate
(3) Location of VIN number

The machine was marked with nameplates (1) and (2), as well as the serial number (2) on a highlighted rectangular field on the machine frame. The serial number and nameplates can be found as shown in Figure (2.1).

When purchasing the machine, check the conformity of the serial numbers on the machine with the number written on the WARRANTY CARD, in the sales documents and in the USER MANUAL. The meaning of the individual fields on the nameplates is shown in the tables.

Record the serial number of the trailer in the top field.

Table 2.1 UE nameplate markings

| ITEM | Meaning |
|------|--|
| A | Category, subcategory and vehicle speed rating |
| B | Approval number |
| C | Product VIN number |
| D | Permissible total weight |
| E | Permissible load per coupling |
| F | Maximum permissible mass per axle 1 |
| G | Maximum permissible mass per axle 2 |
| H | Maximum permissible mass per axle 3 |
| I | Technically permissible towable masses |

**Figure 2.2** Nameplate

Table 2.2 CE nameplate markings

| ITEM | Meaning |
|------|--|
| A | Product trade name or generic designation and function |
| B | Product VIN number |
| C | Product type (granted in the EU type-approval process) |
| D | Year of production |
| E | Product model |

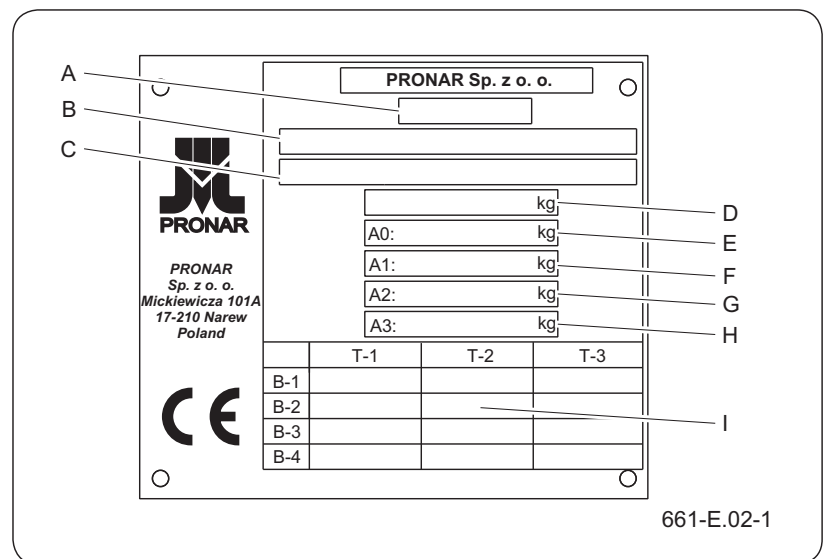
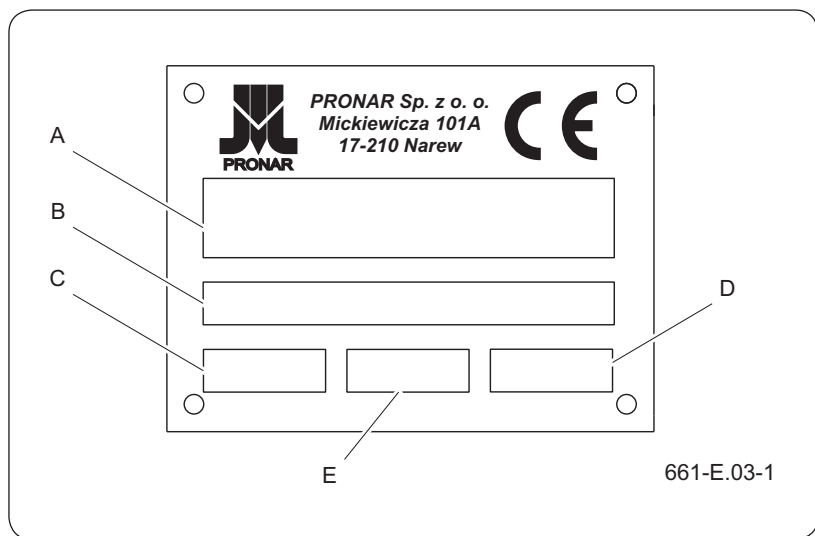

Figure 2.3 CE Nameplate

2.2 INTENDED USE OF THE MACHINE

2.2.1 Using the machine in accordance with intended use



DANGER

The machine may not be used for purposes other than those for which it is intended.

The septic tanker is designed for work related to the transport, pumping and spreading of liquid substances such as slurry, water (not intended for food purposes), municipal sewage and clarified sludge. The machine can be used in field work, within the farm and for driving on public roads.

Failure to comply with the recommendations for the transport and loading of goods specified by the Manufacturer and the regulations on road transport in force in the country in which the machine is used will invalidate the warranty and is treated as using the vehicle contrary to its intended use.

The septic tanker is not adapted and intended for the transport of people, animals and goods classified as hazardous materials.

The braking system as well as the lighting and signalling system meet the requirements arising from traffic regulations.

In the countries where the machine is used, the limits stipulated by the road traffic law in force in a given country must be observed.

The machine speed cannot exceed the maximum design speed of 40 km/h.

Intended use also includes all activities related to the correct and safe operation and maintenance of the machine. Therefore, the user is obliged to:

- read the content of trailer's *USER MANUAL* and with *WARRANTY CARD* and to the guidelines contained in these documents,
- understanding of the principle of machine operation and the safe and proper operation of the vehicle,
- act in compliance with established maintenance and adjustment plans,

- work in compliance with general safety regulations,
- accident prevention,
- comply with the road traffic regulations and transport regulations in force in the country in which the machine is used,
- become familiar with the content of the tractor unit operator's manual and follow its recommendations,
- couple the vehicle only with such an agricultural tractor that meets all the requirements set by the machine's Manufacturer.

The septic tanker may only be used by persons who:

- become familiar with the contents of publications and documents attached to the machine and the contents of manual of agricultural tractor,
- have been trained in the use of the machine and work safety,
- have the required driving license and are familiar with the road traffic regulations and transport regulations.

2.2.2 Expected misuse

The expected improper use of the machine is related primarily to the transport of materials that do not comply with the manufacturer's recommendations, for example:

- transport of people, animals,
- slurry storage (gas production and accumulation),
- transport of dangerous materials, loads that have an aggressive effect as a result of chemical reactions on the structural elements of the machine (causing steel corrosion, damaging paint coatings, dissolving plastic elements, destroying rubber elements, etc.),

- transport of improperly secured cargo that could cause road and environmental pollution while driving,
- driving with improperly secured elements of the machine's equipment, which could cause dangerous road situations while driving,

An employee who has not been trained in the field of operation and safety at work, does not have appropriate qualifications and the required skills cannot be allowed to operate the machine.

When operating the machine, it is strictly forbidden to:

- stay in the danger zone,
- climb onto the machine while it is working,
- make any unauthorized design changes,
- repairs and service by unauthorized and unqualified personnel.

INF.3.G-002.01.EN

2.3 AGRICULTURAL TRACTOR REQUIREMENTS

Table 2.3 Agricultural tractor requirements

| Content | Unit | Requirements |
|---|---------|--|
| | | TG110 |
| Braking system - sockets | | |
| Pneumatic 2 - line | - | in accordance with ISO 1728 |
| Maximum pressure of the system | | |
| Hydraulic | bar/MPa | 200 / 20 |
| Pneumatic | bar/kPa | 8 / 800 |
| The hydraulic system | | |
| Hydraulic oil | - | L HL 32 Lotos ⁽¹⁾ |
| Maximum pressure of the system | bar/MPa | 200 / 20 |
| Electrical system | | |
| Connection of electrical installation | V | 12 |
| Lighting socket | - | 7-pole according to ISO 1724 |
| Remote control power socket | | 3-pole |
| Tractor hitch required | | |
| Type of hitch | - | lower transport hitch |
| Minimum vertical load capacity of the hitch | kg | 3,000 |
| Rear power take-off (PTO) | | |
| Type | - | Type 1 (1 3/8") according to ISO 730-1 |
| Rotational speed | rpm | 540 |
| Number of splines on the shaft | pcs | 6 |
| Rotation direction | - | clockwise |
| Other requirements | | |
| Minimum tractor power requirement | kW/HP | 59 / 80 |

⁽¹⁾ – it is allowed to use other oil, provided that it can be mixed with the oil flooded in the trailer. Detailed information can be found in the product information sheet.

2.3.1 Minimum load on the front axle of the tractor

The front axle of the agricultural tractor must always be loaded with at least 20% of the empty weight of



CAUTION

The load on the front axle of the tractor must be at least 20% of its own weight - this also applies to transporting a loaded trailer. If this condition is not met, additionally load the front axle. danger



DANGER

Inadequate weighting of the front axle of the tractor may cause damage, insufficient stability and the ability to steer and brake the tractor.

the tractor.

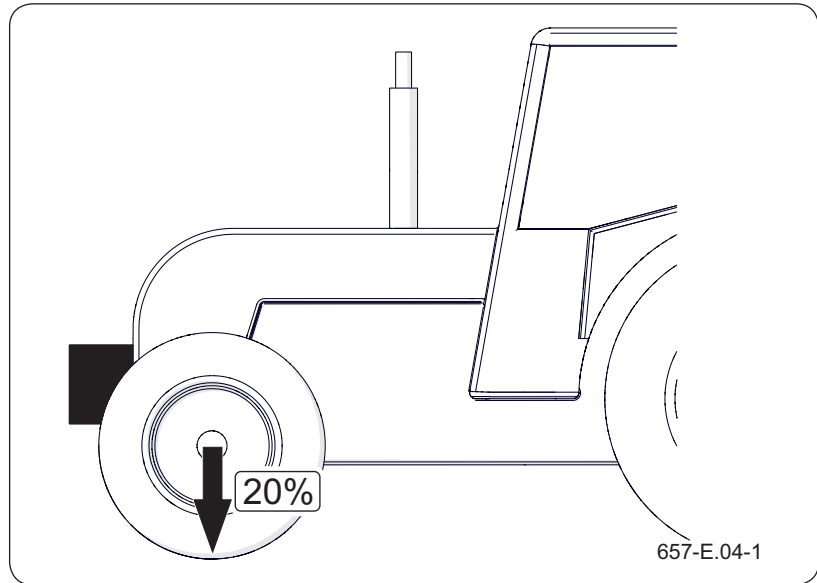

Figure 2.5 Minimum load on the front axle of the tractor

INF.3.G-003.01.EN

2.4 MACHINE EQUIPMENT

Table 2.4 Slurry tank equipment

| Content | STANDARD | ADDITIONAL | OPTIONAL |
|---|----------|------------|----------|
| User Manual | • | | |
| Warranty Card | • | | |
| Electrical connection cable | • | | |
| Electrical installation of the lighting | • | | |
| Wheel chocks | • | | |
| Ladder | • | | |
| Drawbar support | • | | |
| Pivot tension member (50 | • | | |
| Ball tension member K80 | | | • |
| Tank made of plastic | • | | |
| Suction pipes | • | | |
| Parking brake | • | | |
| Articulated shaft | • | | |
| Rear steering axle with hydraulic steering lock | | | • |
| Two-line air brake system | • | | |
| Dosage system (spreader) | • | | |
| Filling and mixing system | • | | |
| Docking mechanism | | • | |
| Filling level indicator | • | | |
| Toolbox | • | | |
| Hydraulic outlets to the rear | | • | |

⁽¹⁾ - Some items of standard equipment, which are listed in the table, may not be present in the trailer supplied. This is due to the possibility of ordering a new machine with a different set - optional equipment, replacing standard equipment.

Information on tyres is included at the end of the publication in ANNEX A.

2.5 TRANSPORT

2.5.1 Trucking



DANGER

During road transport, the machine must be secured on the platform of the means of transport in accordance with safety requirements and regulations.

When driving, the driver of the car should exercise extreme caution. This is due to the fact that the centre of gravity of the vehicle with the loaded machine has been shifted upwards.

Use only approved and technically reliable securing measures. Familiarise yourself with the contents of the attachment manufacturer's Operating Instructions.

Improper use of restraints can cause an accident.

The machine is prepared for sale fully assembled and requires no packaging. Only the machine's technical and operating documentation and possibly some accessories are packaged. Delivery to the user is made by truck or self-transport (towing the machine with a carrier).

Load and unload the machine from the vehicle using the loading ramp with the help of an agricultural tractor. Follow the general health and safety rules for handling work when working. Persons operating handling equipment must have the required authorisation to use the equipment. The machine must be correctly connected to the tractor in accordance with the requirements in this manual. The braking system of the machine must be applied and checked before driving down or up the ramp.

The machine should be attached firmly to the platform of the vehicle using straps, chains, lashings or other fastening devices equipped with a tensioning

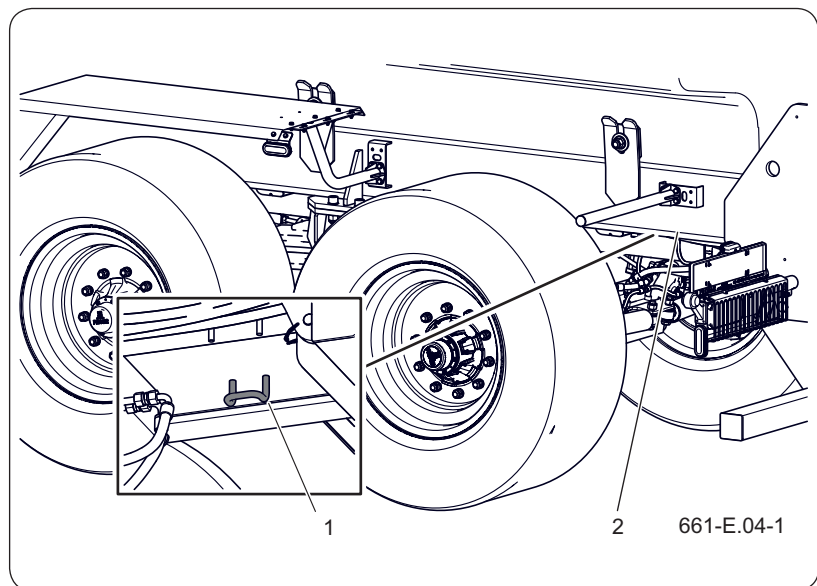

Figure 2.6 Fixing points
(1) handle (2) bottom frame

**CAUTION**

It is forbidden to attach slings and fastenings of any kind to hydraulic, electrical or flaccid machine components (e.g. guards, cables).

mechanism. Secure the fastening elements in the transport fixtures (1) intended for this purpose.

Place chocks or other items without sharp edges under the wheels of the machine to prevent the machine from rolling. Wheel locks must be fixed to the vehicle's load platform in such a way that they cannot move.

Use approved and technically sound means of fastening. Wear on the straps, cracked fixing lugs, bent or corroded hooks or other damage may disqualify a measure for use. Refer to the manufacturer's instructions for the fixing agent used. The number of fastening elements (ropes, belts, chains, lashings, etc.) and the force needed for their tension depends, among others, on the weight of the trailer, the construction of the car carrying the machine, the speed of travel and other conditions. For this reason, it is not possible to define the attachment plan in detail.

For optimum attachment of the machine on the load platform, support the drawbar with a wooden block underneath. A correctly secured machine will not change its position in relation to the transporting vehicle. The fixing means must be selected according to the guidelines of the manufacturer of these components. In case of doubt, a larger number of attachment and securing points for the machine should be used. If necessary, protect the sharp edges of the machine, thus protecting the means of attachment from damage during transport.

When handling, take special care not to damage the machine's fittings and paintwork.

2.5.2 Own transport

If you decide to transport the machine yourself after purchasing it, read and follow the machine's User Manual. Self-transport involves towing the machine with its own agricultural tractor to its destination.



CAUTION

When transporting yourself as an operator, read and follow the contents of this Operating Manual.

When driving, adapt your speed to the prevailing road conditions, but do not exceed the permitted design speed.

INF.3.G-005.01.EN

2.6 TERMS OF WARRANTY

ADVICE

You should require the seller to carefully fill out the Warranty Card and complaint coupons. The lack of e.g. date of sale or point of sale stamp exposes the user to not accept any complaints.

PRONAR Sp. z o.o. in Narew guarantees smooth operation of the machine when it is used in accordance with the technical and operational conditions described in the *USER MANUAL*. Deadline for completion of repairs is specified in the *Warranty Card*.

The warranty does not apply to parts and sub-assemblies of the machine, which are subject to wear in normal operating conditions, regardless of the warranty period.

The warranty services only apply to such cases as: mechanical damage not caused by the fault of the user, factory defects of parts, etc.

In the event that damage occurs as a result of:

- mechanical damage caused by the user's fault, road accident,
- from improper operation, adjustment and maintenance, using the machine contrary to its purpose,
- use of a damaged machine,
- repairs carried out by unauthorized persons, improper repairs,
- execution of user changes in machine design,

the user loses the warranty.

Modifications to the machine without the written consent of the Manufacturer are prohibited. In particular, welding, reaming, cutting and heating of major structural components of the machine that directly affect safety during use is not permitted.

Detailed warranty conditions are given in the *WARRANTY CARD* attached to the newly purchased machine.

INF.3.B-006.02.EN

2.7 ENVIRONMENTAL RISK



DANGER

Do not store oil waste in containers for food.

Store used oil in hydrocarbon-resistant containers.



ATTENTION

Waste oil should only be taken to the appropriate facility dealing with the re-use of this type of waste. Do NOT dispose of or pour oil into sewerage drains or water reservoirs.

A hydraulic oil leak constitutes a direct threat to the natural environment owing to its limited biodegradability. Maintenance and repair work which involves the risk of an oil leak should be performed in the rooms with oil resistant surface. In the event of oil leaking into the environment, first of all contain the source of the leak, and then collect the leaked oil using available means. Remaining oil should be collected using sorbents, or by mixing the oil with sand, sawdust or other absorbent materials. The oil contaminations, once gathered up, should be kept in a sealed, marked, hydrocarbon resistant container, and then passed on to the appropriate oil waste recycling centre. The container should be kept away from heat sources, flammable materials and food.

Oil which has been used up or is unsuitable for further use owing to loss of its properties should be stored in its original packaging in the conditions described above. Detailed information on hydraulic oils can be found in the Material Safety Data Sheets.

INF.3.B-007.02.EN

2.8 WITHDRAWAL



DANGER

During dismantling, use appropriate tools and equipment (overhead cranes, elevators, lifts, etc.) and use personal protective equipment, i.e. protective clothing, footwear, gloves, glasses, etc.

Avoid oil contact with skin. Do not allow oil to leak.



DANGER

Before commencing dismantling, reduce residual pressure in pneumatic and hydraulic systems.

In the event of decision by the user to withdraw the machine from use, comply with the regulations on withdrawal from use and recycling of machines withdrawn from use in force in a given country.

Before proceeding to dismantling, reduce the residual pressure in the hydraulic system, drain the oil completely. Remove all air from the pneumatic system of the machine by draining the air reservoir.

In the event of replacement of parts, take the worn or damaged elements to a collection point for recyclable materials. Take used oil as well as rubber or plastic elements to plants dealing with the utilization of this type of waste.

Table 2.5 Codes of waste generated by dismantling of the machine

| Item | Code | Meaning |
|------|-----------|---|
| 1 | 07 02 13 | Plastic waste |
| 2 | 13 01 10 | Other hydraulic oils |
| 3 | 13 02 04* | Mineral engine, gear and lubricating oils containing halogenated organic compounds |
| 4 | 13 02 06* | Synthetic engine, gear and lubricating oils |
| 5 | 13 02 08* | Other engine, gear and lubricating oils |
| 6 | 13 05 02* | Sludges from oil dewatering in separators |
| 7 | 13 05 08* | A mixture of sand trap waste and oil dewatering in separators |
| 8 | 15 01 10* | Packaging containing residues of or contaminated by hazardous substances |
| 9 | 15 02 02* | Sorbents, filter materials and protective clothing contaminated with hazardous substances |
| 10 | 16 01 03 | Worn tires |
| 11 | 17 04 05 | Iron and steel |
| 12 | 17 04 11 | Cables other than those mentioned in 17 04 10 |

Chapter 3

Safety of use

PRONAR TG214

3.1 BASIC SAFETY RULES



CAUTION

The machine may only be used and operated by **persons qualified** to drive agricultural tractors with a trailer.

- Before using the machine, please read carefully the content of this publication and the „*Warranty Card*“. During operation, follow all recommendations.
- The user manual should be available to the operator for all the time. Protect the manual from damage.
- If the information contained in the User's Manual is difficult to understand, contact a seller who runs an authorized technical service on behalf of the manufacturer, or contact the manufacturer directly.
- If you ignore the recommendations contained in these document, you create a threat to the health and life of bystanders and/or the machine operator.
- Use and operate the machine carefully! By a careless work, you create a threat to the health and life of bystanders and/or the machine operator.
- You are obliged to familiarize yourself with the construction, operation principles and safe operation of the machine.
- Familiarize yourself with all machine controls before starting work. Do not use the machine without knowing its function.
- Before each start-up of the machine, check that it is properly prepared for work, first of all in terms of safety.
- There is a residual risk of threats, therefore the basic principle of using the machine should be the application of the principles of safe use and sensible behaviour. Remember that your safety is the most important thing.
- It is forbidden to use the machine by persons

who are not authorized to drive carriers, including children, people under the influence of alcohol, drugs or other intoxicating substances, etc.

- The machine may not be used for purposes other than those for which it was intended. Everyone who uses the machine in a manner contrary to its intended use, thus takes full responsibility for all consequences arising from its use.
- Use of the machine for purposes other than envisaged by the Manufacturer is inconsistent with the intended use and may void the warranty.

BHP.3.G-001.01.EN

3.2 SAFETY DURING COUPLING OF THE MACHINE



DANGER

Be especially careful when connecting the machine.

- Do not connect the machine to the tractor, if it does not meet the requirements set by the Manufacturer (minimum power demand of the tractor, inadequate connections, etc.) - see the section "*Tractor requirements*".
- Before connecting the machine, make sure that the oil in the external hydraulic system of the tractor may be mixed with the hydraulic oil of the machine.
- Before coupling of the machine, make sure that both machines are technically sound.

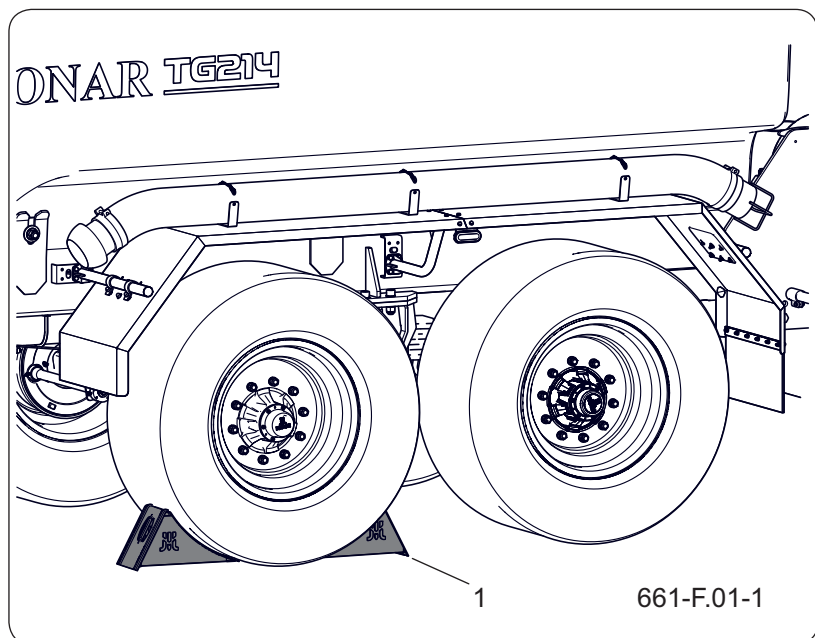

Figure 3.1 Position of the locking wedges

(1) support wedge

- When connecting of the machine to the tractor, use the the appropriate hitch of the tractor. After completing the coupling of the machines, check the coupling protection. Familiarize yourself with the content of the tractor operator's manual. If it is equipped with an automatic hitch, make sure the aggregation operation is complete.



CAUTION

Place wedges only under the wheels of the rigid axle.

- Be especially careful when connecting the machine.
- When attaching, there must be nobody between the machine and the tractor.
- You may couple and uncouple the machine only when the machine is immobilized with the parking brake. If the trailer is standing on a slope or hill, additionally protect it against rolling by placing chocks or other elements without sharp edges under the wheels. Secure the thru-axle wheels. Make sure that the wedges are on the machine.
- Do not move the machine when the support is extended and rests on the ground. While the machine is moving, there is a risk of damage to the support.
- It is forbidden to support the loaded machine with the parking stand. Unload the load before disconnecting the machine from the tractor.

BHP.3.G-002.01.EN

3.3 SAFETY WHEN OPERATING THE HYDRAULIC AND PNEUMATIC SYSTEMS



DANGER

The hydraulic and pneumatic systems are under high pressure during operation.

- Regularly check the technical condition of the connections and the hydraulic and pneumatic lines. Machine operation with a leaking system is forbidden.
- In the event of a hydraulic or pneumatic installation failure, the trailer should be turned off from operation until the failure is removed.
- When connecting the hydraulic conduits to the tractor, make sure that the tractor and machine hydraulic systems are not under pressure. If necessary, reduce the residual pressure in the installation. See chapter „*Hydraulic system handling...*”.
- Use hydraulic oil recommended by the manufacturer.
- After changing the hydraulic oil, the used oil must be disposed of. Used oil or oil which has lost its properties should be stored in original containers or replacement packaging resistant to hydrocarbons. Replacement containers must be accurately described and properly stored.
- It is forbidden to store oil in packaging intended for food storage.
- Rubber hydraulic hoses should be replaced every 4 years regardless of their technical condition.

Procedure in the event of an accident

- In the event of injuries being caused by pressurized hydraulic oil, contact a doctor immediately. Hydraulic oil can penetrate the skin and cause infection.
- If the oil gets into the eyes, rinse with plenty of

water and if irritation occurs, contact a doctor.

- In the event of contact of oil with skin wash the area of contact with water and soap. Do not use organic solvents (petrol, kerosene).

BHP.3.G-003.01.EN

3.4 PRINCIPLES OF SAFE MAINTENANCE

- Keep the machine clean.
- During the warranty period, any repairs should be performed only by Warranty Service authorized by the manufacturer. After the end of the warranty period, it is recommended that any repairs shall be carried out by specialized workshops.
- Whenever you find any faults in operation or damage to the machine, do not use it until it is repaired.
- During maintenance work, use appropriate, close-fitting protective clothing, gloves, shoes, glasses and the right tools.
- Any modifications to the machine release the Manufacturer Pronar Sp. z z. o company from liability for any damage or health detriment.
- The machine may only be entered when it is absolutely motionless and the tractor engine is turned off. Secure the set with the parking brake. Secure the tractor cabin against access by unauthorized persons.
- Regularly check the technical condition of the safety devices and the correct tightening of the screw connections (in particular the drawbar eye and wheels).
- Carry out inspections of the machine in accordance with the frequency specified in this manual.
- Before commencing repair works on hydraulic or pneumatic systems, reduce residual oil or air pressure completely. How to proceed See chapter „*Hydraulic system handling...*” , „*Pneumatic system handling...*”
- Carry out repair, maintenance and cleaning works only with the tractor engine turned off

and the ignition key removed. Secure the tractor and the machine with the parking brake and additionally place chocks under the machine wheel. Secure the tractor cabin against access by unauthorized persons.

- Should it be necessary to replace individual elements, use only the parts recommended by the Manufacturer. If you do not comply with these requirements, you may pose a threat to the health or life of bystanders or machine operators, and contribute to machine damage. This is grounds for voiding the warranty.
- Before welding or electric works, disconnect the machine from the power supply. Clean the paint coating. Burning paint fumes are poisonous to humans and animals. Perform welding work in a well-lit and ventilated room.
- During welding work pay attention to flammable or fusible elements (elements of pneumatic, electric and hydraulic systems, elements made of plastics). If there is a risk that they will catch fire or be damaged, remove them or cover them with non-flammable material before welding. Before starting work, have a CO₂ fire extinguisher or foam extinguisher ready.
- In the event of work requiring the machine to be raised, use properly certified hydraulic or mechanical lifts for this purpose. After lifting the machine use additional stable and durable supports. You cannot perform any work under the machine, which has only been lifted with the jack.
- Do not support the machine with fragile elements (bricks, hollow blocks, concrete blocks).
- After completing work connected with lubrication, remove excess oil or grease. Keep the

machine clean.

- You cannot repair elements of the hydraulic or pneumatic system yourself, i.e. control valves, actuators and regulators. In the event of damage to these elements, have them repaired at an authorized repair point or replace the elements with new ones.
- You may not install additional devices or accessories that do not comply with the specifications defined by the Manufacturer.
- You may tow the machine only when the axle, lighting and braking systems are functional.

BHP.3.G-004.01.EN

3.5 DESCRIPTION OF RESIDUAL RISK

Pronar Sp. z o. o. in Narew has made every effort to eliminate the risk of an accident. However, there is some residual risk that can lead to an accident and is primarily associated with the following activities:

- using the machine for purposes other than described in the manual,
- being between the tractor and the machine when the engine is running and when connecting the machine,
- operation of the machine by people under the influence of alcohol or other intoxicants,
- operation of the machine by unauthorized persons,
- being on the machine during work,
- cleaning, maintenance and technical inspection of the machine.

Residual risk can be reduced to a minimum by following these recommendations:

- prudent and unhurried operation of the machine,
- reasonable use of the notes contained in the User Manual,
- keeping a safe distance from prohibited and dangerous places,
- a ban on being on the machine while it is working,
- maintenance work carried out by trained personnel,
- using appropriate fitted protective clothing,
- securing the machine against access by unauthorized persons, especially children.

BHP.3.G-005.01.EN

3.6 DRIVING ON PUBLIC ROADS

- When driving on public roads, you must make sure that the machine and tractor are equipped with a certified or approved reflective warning triangle.
- Place a triangular sign on the rear wall.
- Before driving on the road, remove the tail light covers.
- When driving on public roads, comply with the road traffic regulations and transport regulations in force in the country in which the machine is used.
- Do not exceed the maximum design speed 40km/h. The driving speed must be adapted to the environmental conditions and the load. If possible avoid driving over rough terrain and unexpected turns.
- Never leave the machine unsecured. The machine disconnected from the tractor must be without load, immobilized with the parking brake and secured against rolling away with the use of wedges or other elements without sharp edges placed under the vehicle wheel.
- Before driving, make sure that the machine is correctly attached to the tractor, especially that the hitch pins are secured.
- Vertical load carried by the machine drawbar eye affects the steering of the agricultural tractor.
- Before each use of the machine, check its technical condition, especially in terms of safety. In particular, check the technical condition of the hitch system, chassis, braking system and light signaling, as well as connection elements of the hydraulic, pneumatic and electrical systems.

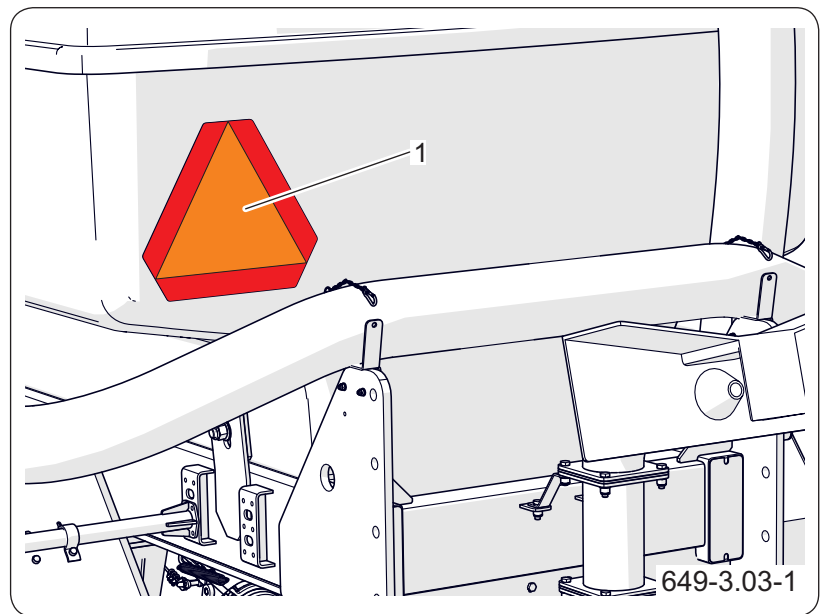

Figure 3.2 Warning triangle

(1) Plate for slow-moving vehicles

- Make sure the parking brake is released before driving.
- The machine is adapted for driving on slopes up to a maximum of 8°. Driving with machine on steeper slopes may of the machine the set to tip over as a result of loss of stability.
- Periodically drain the air reservoir in the pneumatic system. During frosts, freezing water may cause damage to pneumatic system components.
- Reckless driving and high speed can cause an accident.
- It is forbidden to transfer materials not permitted by the Manufacturer.
- Do not exceed the maximum machine loading capacity. Exceeding of the loading capacity may lead to damage to the machine, loss of stability and cause a hazard while driving. The braking system of the machine has been adjusted to the total weight of the machine, exceeding which will drastically reduce the operation of the main brake.

- Prolonged driving on slopes creates the risk of losing braking effectiveness.
- When reversing, use the help of another person. While manoeuvring, the helping person must keep a safe distance from the danger zones and be visible to the tractor operator at all times.
- It is forbidden to get on the machine while driving.
- It is forbidden to park the trailer on a slope without proper securing. Secure the machine against rolling using the parking brake. Place wedges or other elements without sharp edges under the wheels.

BHP.3.G-006.01.EN

3.7 WORKING WITH THE MACHINE WITH THE POWER TAKE-OFF (PTO)



CAUTION

Before starting work, read the operator's manual of the drive shaft provided by the shaft manufacturer.

- Before starting work, read the operator's manual of the drive shaft provided by the shaft's manufacturer and follow the recommendations contained therein.
- If necessary, adjust the length of the articulated telescopic shaft to the cooperating tractor in accordance with the shaft's instruction manual.
- The machine may only be connected to the tractor with the use of a properly selected articulated telescopic shaft recommended by the Manufacturer.
- The drive shaft must be equipped with guards. It is forbidden to use the shaft with damaged or missing safety elements.
- Some parts of the PTO shaft (especially the clutch) can become very hot. Do not touch hot parts.
- After installing the shaft, make sure that it is correctly and securely connected to the tractor and the machine.
- Do not wear loose clothing, loose belts or anything that could get caught in a rotating shaft. Contact with the rotating articulated telescopic shaft may cause serious injuries.
- Before disconnecting the shaft, turn off the tractor engine and remove the key from the ignition switch.
- When working in conditions of limited visibility, use the tractor's working lights to illuminate the articulated telescopic shaft and its surroundings.
- During transport, the shaft should be stored in a horizontal position so as to avoid damaging the guards and other securing elements.
- When using the shaft and the machine, do not

use PTO rotation speed other than 540 rpm. Do not overload the shaft and the machine, do not engage the clutch suddenly. Before starting the articulated telescopic shaft, make sure that the PTO rotation direction is correct.

- Do not go over or under the shaft and do not stand on it, both during operation and when the machine is stopped.
- The articulated telescopic shaft has markings on the casing, indicating which end of the shaft should be connected to the tractor.
- Never use a damaged PTO shaft, it may cause an accident. Repair the damaged shaft or replace it with a new one.
- Do not use PTO shaft extensions / adapters.
- Disconnect the drive of the shaft each time when there is no need to drive the machine, or when the tractor and the machine are in an unfavourable angular position to each other.
- Prevent the shaft cover securing chain from turning while the shaft is working, and attach it to a fixed structural element of the machine.
- Do not use safety chains to support the shaft when the machine is parked or transported, use the handle on the drawbar of the machine.

BHP.3.G-007.01.EN

3.8 INFORMATION AND WARNING STICKERS

- The machine is marked with the information and warning stickers listed in the table below.
- The layout of the symbols is shown in the figure. The user is obliged to take care of the legibility of inscriptions, warning and information symbols placed on the trailer during the entire period of use.
- If they are damaged, they should be replaced with new ones. Information and warning stickers can be purchased directly from the Manufacturer or from the place where the machine was purchased.
- The part numbers of the stickers can be found in the table and in the Spare Parts Catalogue. New assemblies replaced during repair must be marked again with the appropriate safety signs. When cleaning the machine, do not use solvents that can damage the coating of the labels and do not direct a strong jet of water at them.

Table 3.1 Information and warning stickers







| ITEM | Sticker | Meaning |
|------|---|---|
| 1 |  | PTO shaft speed and direction of rotation 75N-00000004 |
| 2 |  | Read the contents of the operating instructions before use. Before carrying out any maintenance or repair work, switch off the tractor engine and remove the keys from the ignition. Danger of poisoning and explosion. High-pressure fluid. Risk of electric shock. Keep a safe distance from overhead power lines 661N-00000003 |
| 3 |  | Corporate labelling. 566N-97000003-03 |
| 4 |  | Trailer type TG214. 661N-00000001 |
| 5 |  | Tank capacity sticker 661N-00000002 |
| 6 |  | Warning sticker, left. (282x423) |
| 7 |  | Warning sticker, right. (282x423) |



Figure 3.3 Positioning of information and warning stickers

661-F.03-1

BHP.3.G-008.01.EN

Chapter 4

Design and operation

PRONAR TG214

4.1 TECHNICAL SPECIFICATIONS

Table 4.1 Basic technical data

| Content | Unit | TG214 |
|----------------------------------|-------------------|--|
| Dimensions | | |
| Overall length | mm | 8,300 |
| Overall width | mm | 2,550 |
| Overall height | mm | 3,375 |
| Tank parameters | | |
| Length | mm | 5,050 |
| Width | mm | 2,085 |
| Height | mm | 2,000 |
| Capacity | l | 14000 |
| Tank suspension | - | rigid to the chassis frame |
| Tank material | - | Plastics |
| Performance parameters | | |
| Permissible total weight | kg | 20,500 |
| Curb weight | kg | 5,800 |
| Filling - emptying pump | - | cavitation pump (screw) |
| Maximum pump capacity | m ³ /h | 240 |
| Tank filling time | min | 4 |
| PTO speed | rpm | 540 |
| Direction of rotation of the PTO | mm | clockwise |
| Suction coupling | - | 6" Perrot type, left/right side |
| The hydraulic system | | |
| Slider control | - | hydraulic, automatic by remote control |
| Installation pressure | bar | 200 |
| Hydraulic oil | - | L-HL32 Lotus |
| Other information | | |
| Construction speed | km/h | 40 |
| Wheel base | mm | 1,480 |
| Drawbar eye load | kg | 3,000 |
| Power demand | hpm/ kW | 140 / 103 |
| Electrical system voltage | V | 12 |
| Noise level emitted | dB | less than 70 |

*- depending on the legal restrictions in the country of sale and on the completion of the trailer, the above data may differ.

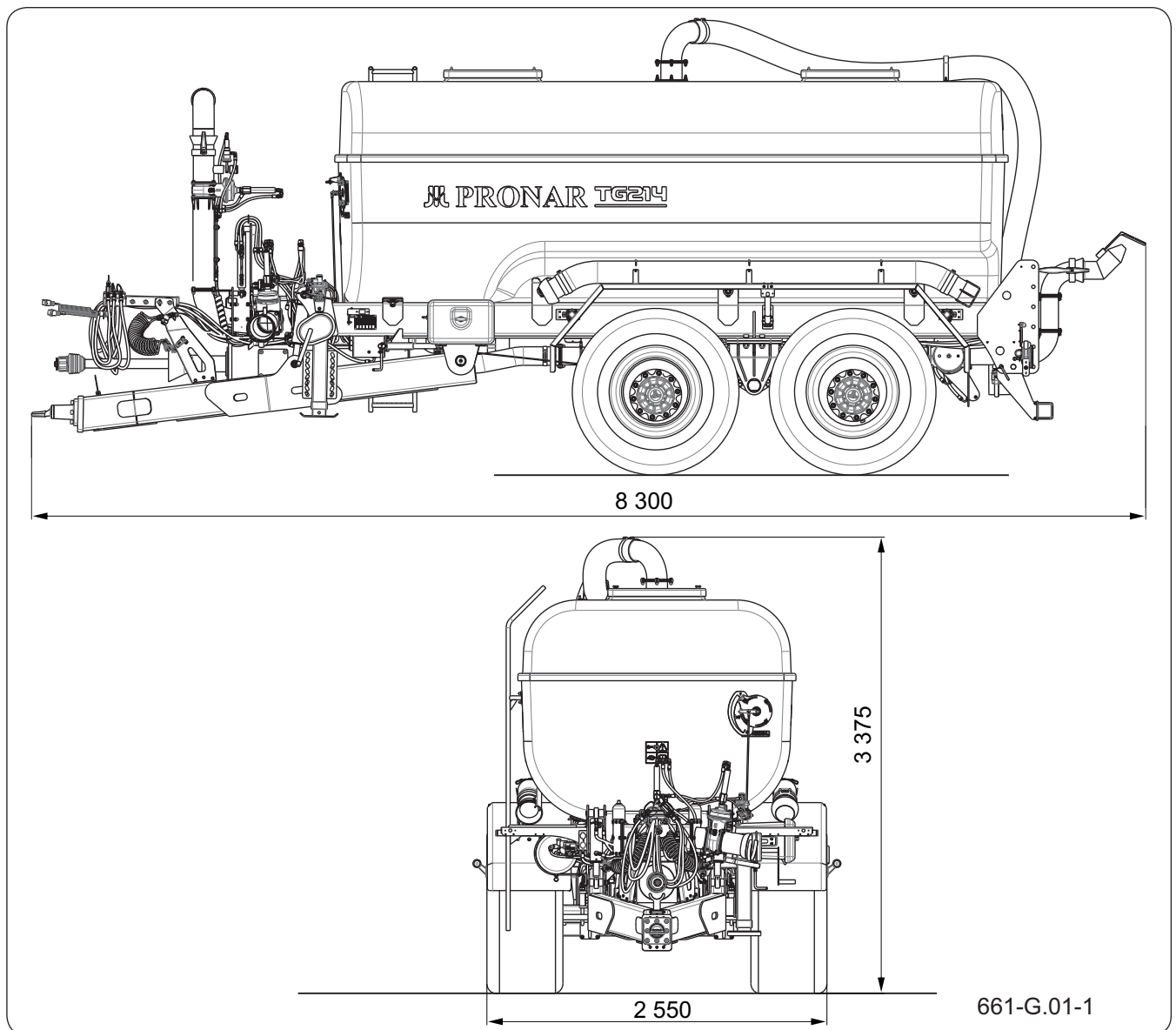

Figure 4.1 Dimensions of the slurry tanker

Table 4.2 Main dimensions of the machine

| Content | Unit | TG214 |
|---------|------|-------|
| Length | mm | 8,300 |
| Height | mm | 3,375 |
| Width | mm | 2,550 |

BIZ.3.G-001.01.EN



CAUTION

Depending on the trailer's accessories, some technical parameters may change.

4.2 MACHINE CONSTRUCTION

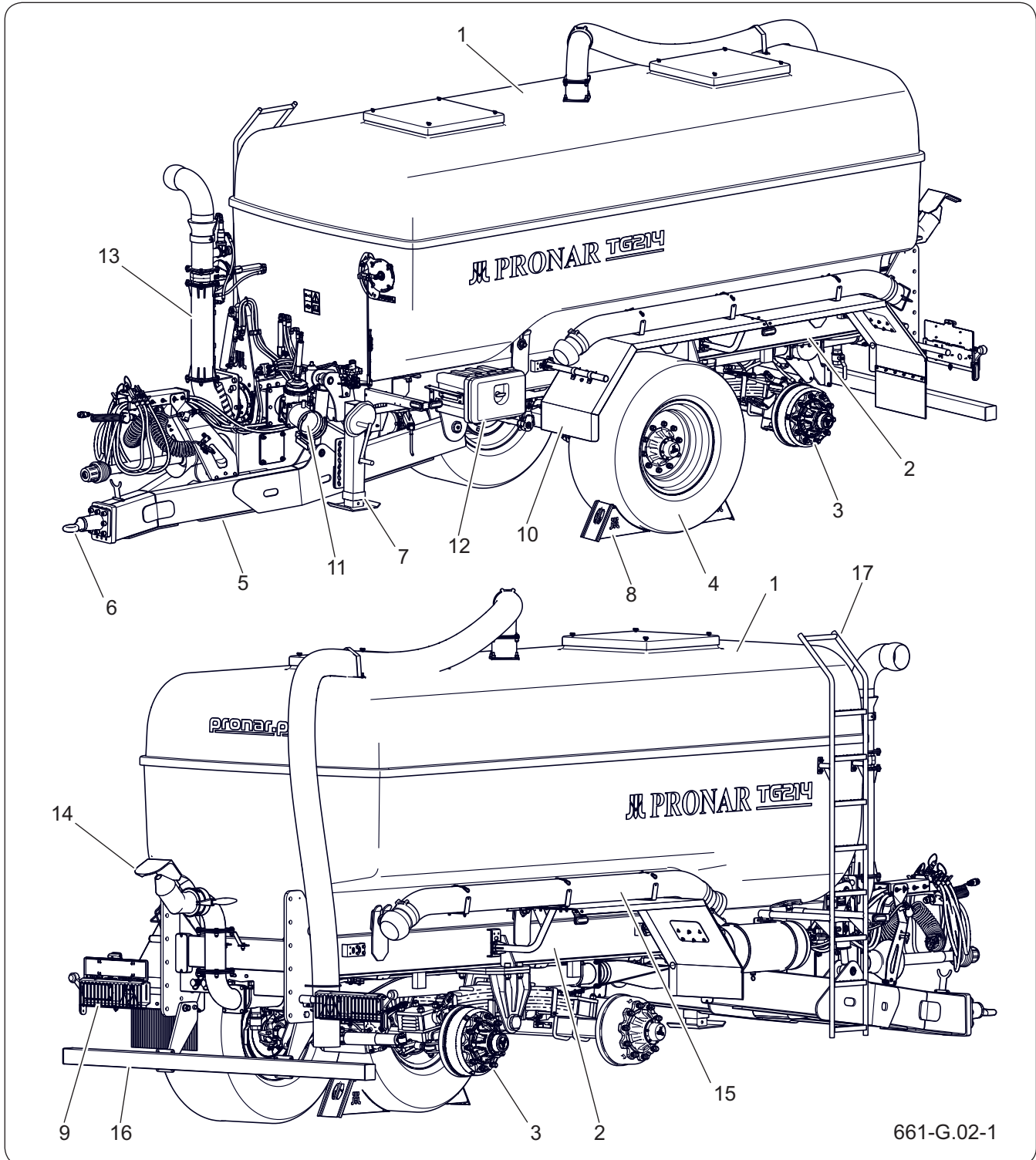

661-G.02-1

Figure 4.2 Machine construction

- | | | |
|---------------------|---------------------|---------------------|
| (1) tank | (2) base frame | (3) running axle |
| (4) wheel | (5) drawbar | (6) drawbar linkage |
| (7) parking support | (8) support wedges | (9) light bar |
| (10) mudguards | (11) filling system | (12) toolbox |
| (13) docking system | (14) spreader | (15) suction pipes |
| (16) rear beam | (17) ladder | |

The machine's running gear is formed by wheels (4) mounted on axles (3), which in turn are attached to a bogie-type pendulum suspension. The running gear was attached to the downframe. A tank (1) made of plastic was set on the frame (2) with screws. The tank is filled and unloaded via a system (11) driven by the tractor's power take-off. Control is by remote control, which carries out the various functions of the filling system.

The machine is coupled to the tractor via a hydraulically suspended drawbar (5).

BIZ.3.G-002.01.EN

4.3 PNEUMATIC BRAKE SYSTEM

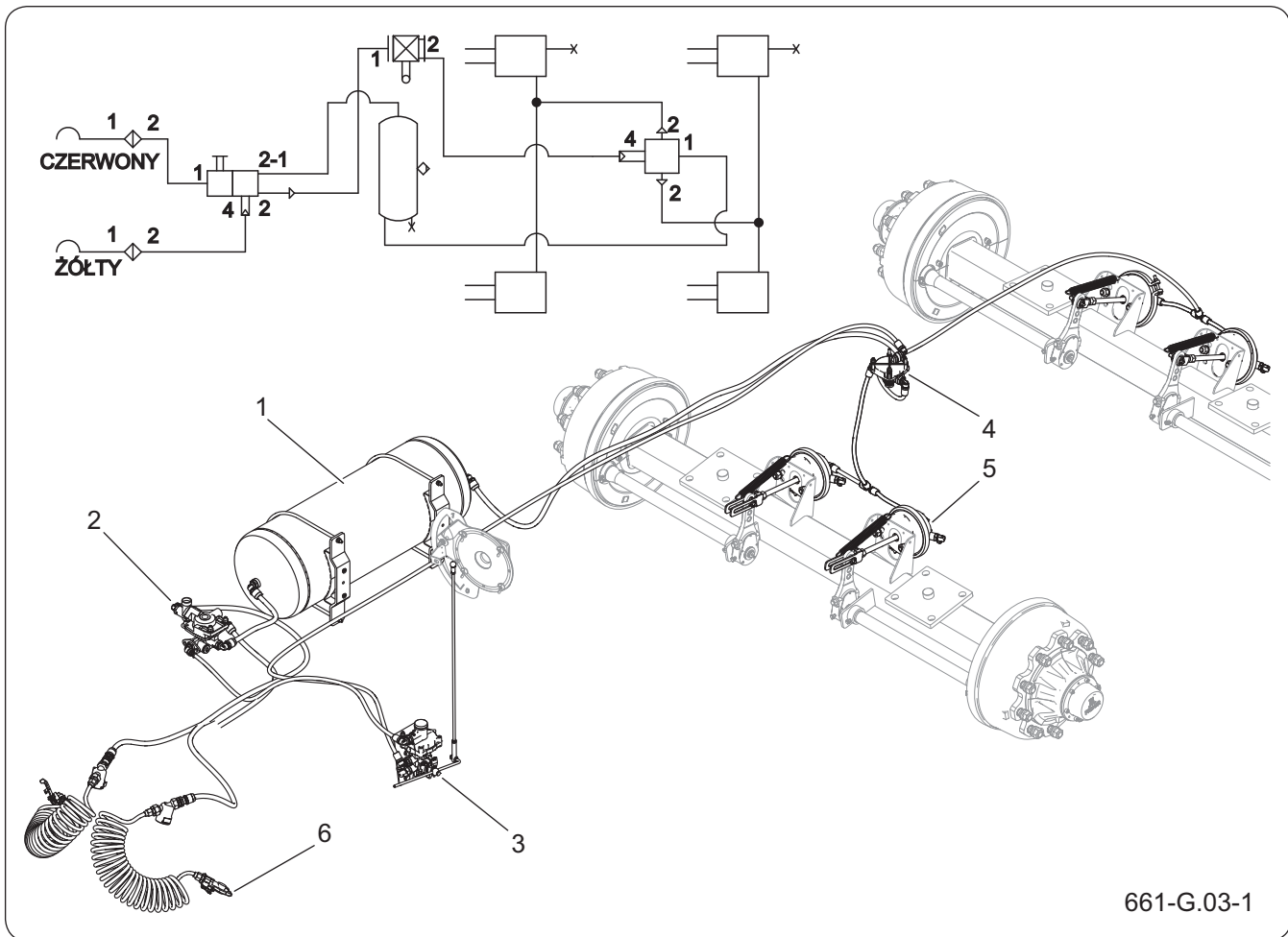

661-G.03-1

Figure 4.3 Diagram and construction of the air brake system

- | | | |
|-------------------|--------------------|---------------------------|
| (1) air reservoir | (2) control valve | (3) brake force regulator |
| (4) relay valve | (5) brake actuator | (6) pneumatic connection |

ADVICE

Connect the yellow wire first, then the red wire.













Disconnect the pneumatic hoses in reverse order.

The pneumatic service brake is operated from the operator's cab by pressing the tractor's brake pedal. In the event of an unforeseen disconnection of the brake line between the machine and the tractor, the control valve (2) automatically operates the machine brake.

The braking system has an automatic brake force regulator (3) that adjusts the braking force of the machine according to the weight of the load being transported.

The control valve - (Figure 4.4) has a button (2) that releases the brake, used when the trailer is uncoupled

Table 4.3 List of symbols used in the diagrams

| Symbol | Description |
|---|---------------------------------|
|  | Pneumatic connection, plug |
|  | Pneumatic connection, socket |
|  | Drainage valve |
|  | Main control valve |
|  | Relay valve |
|  | Automatic brake force regulator |
|  | Manual brake force regulator |
|  | Connection of cables |
|  | Air reservoir |
|  | Brake actuator |
|  | Control valve (connector) |
|  | Air filter |

from the tractor. When the air line is connected to the tractor, the release device automatically moves to a position that allows the brakes to operate normally.

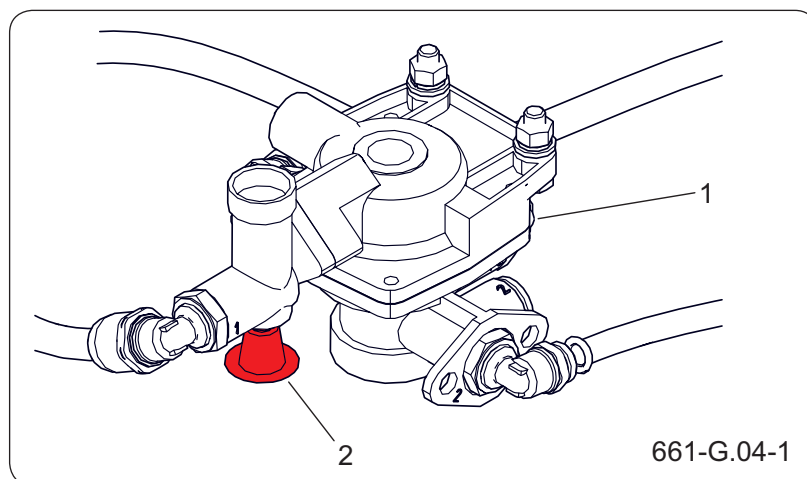

Figure 4.4 Control valve
(1) control valve (2) release button

BIZ.3.G-003.01.EN

4.4 PARKING BRAKE

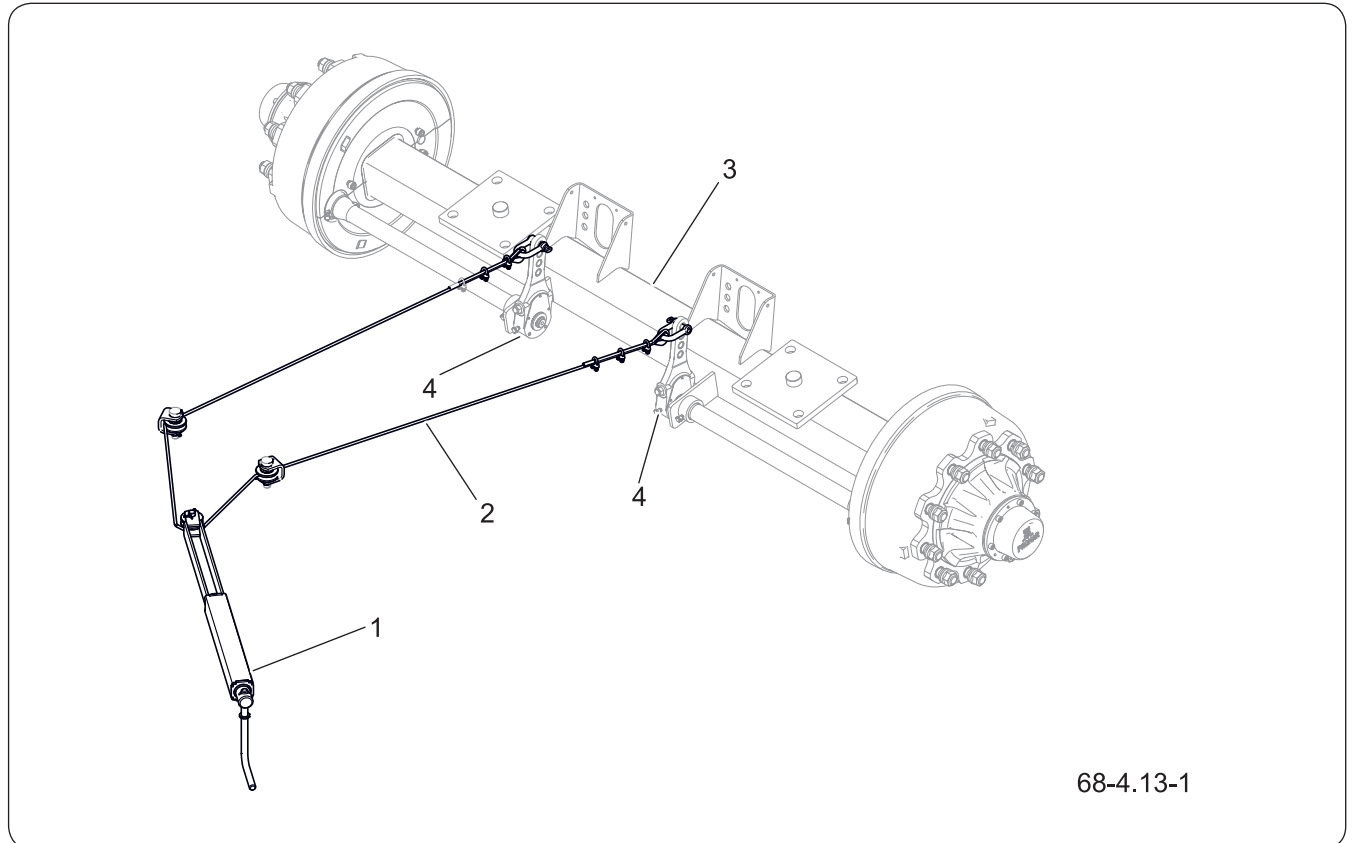

Figure 4.5 Construction of the parking brake

(1) brake mechanism

(2) cable

(3) lever

(4) expander lever

The parking brake is used to immobilize the machine when parked. The brake crank mechanism (1) is connected with steel cables to the levers of the wheel axle expanders (4). By turning the crank of the mechanism (1) clockwise, the steel cable is tightened, causing the lever of the brake expanders to deflect, which, by spreading the brake shoes, immobilizes the machine. Before driving, release the parking brake - the steel cable must hang loosely.

BIZ.3.G-004.01.EN

4.5 TANK

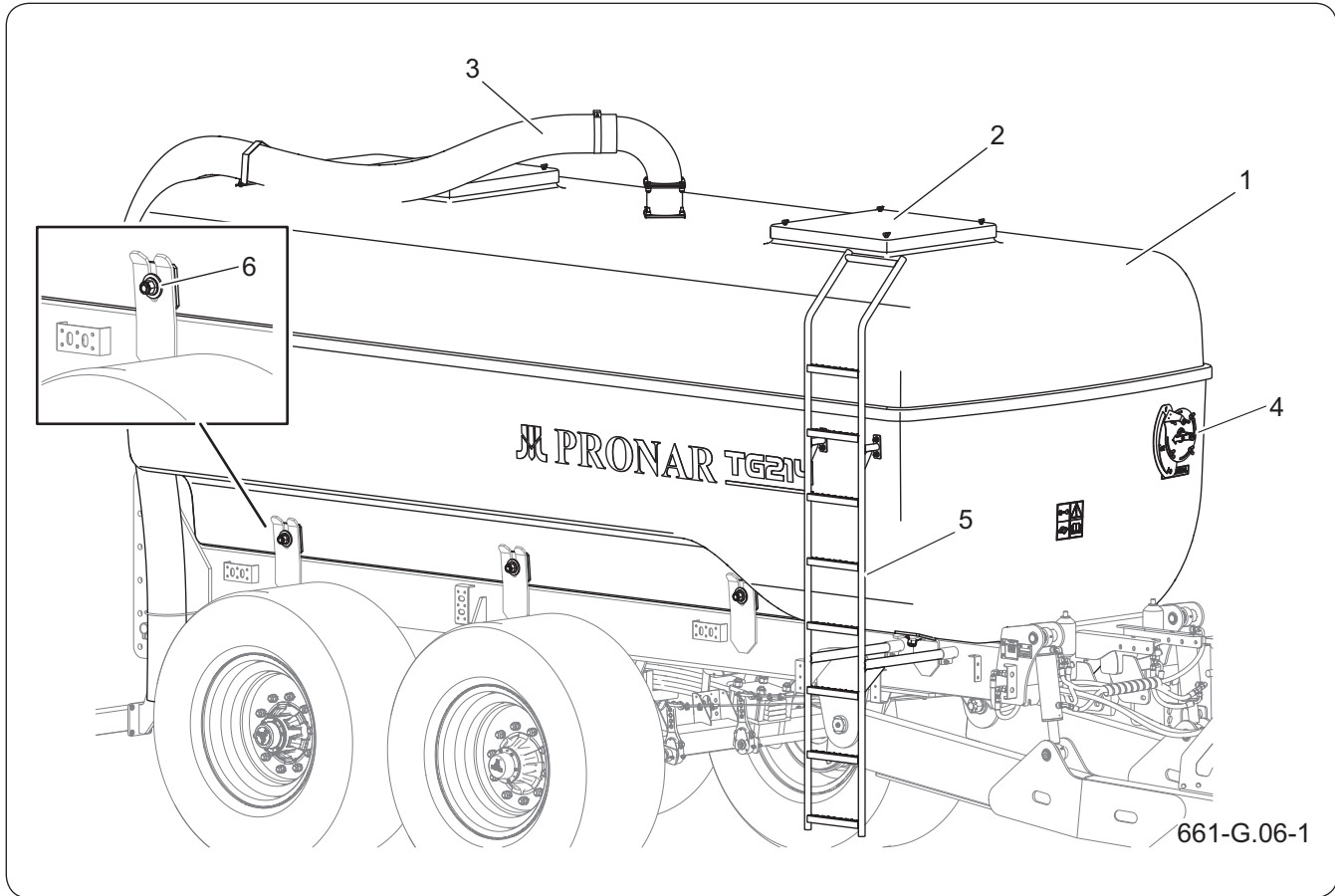

Figure 4.6 Tank construction

- | | | |
|-----------------------------|-------------|------------------------|
| (1) tank | (2) manhole | (3) vent pipe |
| (4) filling level indicator | (5) ladder | (6) fastening elements |



DANGER

Never leave the tank full due to the possibility of toxic vapours and gases accumulating.



CAUTION

After several load runs, check the tightness of the screw connections (6).

The tank (1) is made of a plastic material that is resistant to the aggressive effects of the loads carried. It was fixed to the subframe with screw connections (6). A vent line (3) is fitted to the top of the tank for pressure-free operation of the machine. Pressure or vacuum generated inside the tank can lead to damage. Ensure that the vent is unobstructed. Access to the vent pipe (3) and manholes (2) is provided by a ladder (5). On the front side there is a float-type filling indicator (4)

BIZ.3.G-005.01.EN

4.6 HYDRAULIC DRAWBAR SYSTEM

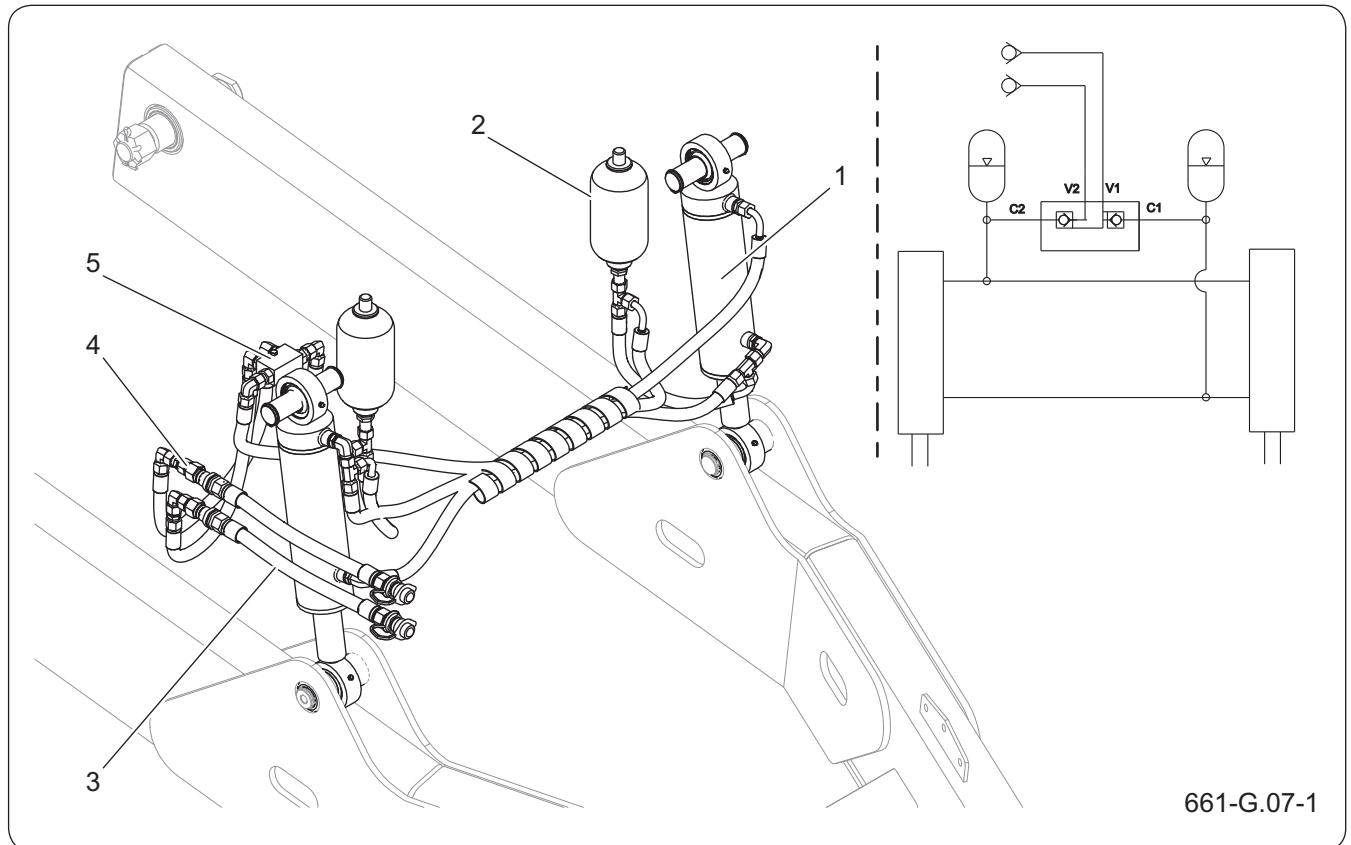

661-G.07-1

Figure 4.7 Structure and diagram of drawbar hydraulic system

- (1) hydraulic actuator (2) hydraulic accumulator (3) hydraulic line
 (4) quick coupling (5) non-return valve

ADVICE

The trailer tipping hydraulic system was filled with L-HL32 Lotos hydraulic oil.

Once the drawbar is set to the correct height, disconnect the hydraulic lines (3). Secure quick-release couplings with plugs.

The hydraulic drawbar suspension system is made up of two hydraulic actuators (1) connected to hydraulic accumulators (2). The connection lines (3) feed the hydraulic suspension system via quick-connectors (4).

BIZ.3.G-006.01.EN



DANGER

Reduce the pressure in the tractor and machine hydraulic system before connecting the lines.

4.7 LIQUID DISTRIBUTION SYSTEM

4.7.1 Construction of the pumping system

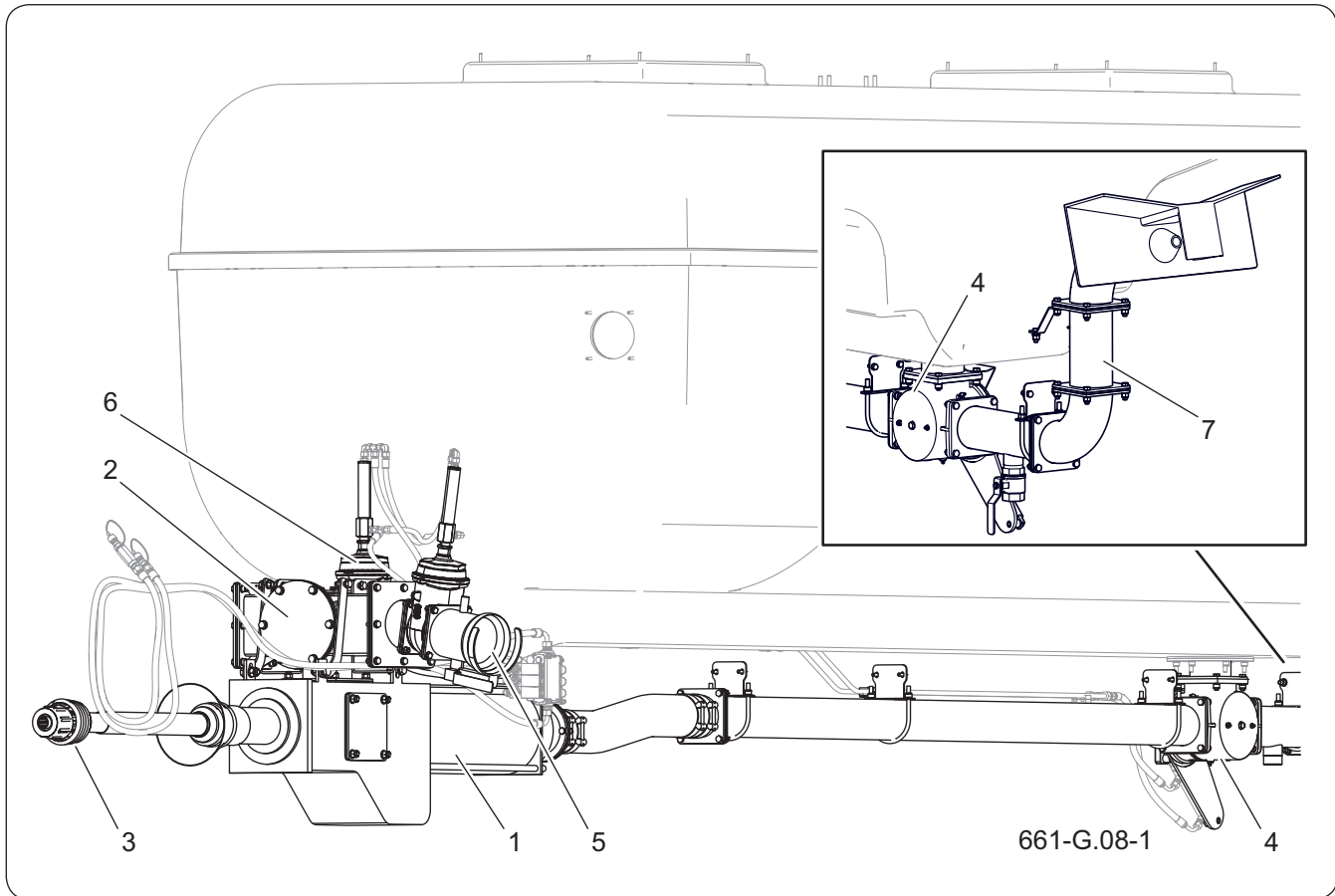

Figure 4.8 Construction of the liquid distribution system

- | | | |
|--------------------------|------------------------|---------------------|
| (1) pump | (2) hose connection | (3) PTO shaft |
| (4) three-way gate valve | (5) suction gate valve | (6) tank gate valve |
| (7) spreader | | |



CAUTION

Before starting the PTO drive, check that the shaft is properly secured, that the direction of rotation is clockwise and that the rotation value is 540 rpm.

It is unacceptable to start the PTO drive in the event of a malfunction of the shaft, damaged shields and when there are bystanders in the vicinity. Be especially careful!

The drive from the tractor is transmitted by means of the PTO shaft (3) to the cavitation (screw) pump (1), which fills or empties the tank by means of gate valves. Appropriate setting of the gate valves mixes the transported medium. The design of the system allows the suction of liquid from the right or left side of the machine.

A spreader (7) is installed in the rear part of the vehicle.

Table 4.4 Rear power take-off PTO

| Parameter | Unit | Requirements |
|--------------------------------|------|--|
| Type | - | Type 1 (1 3/8") according to ISO 730-1 |
| Rotational speed | rpm | 540 |
| Number of splines on the shaft | pcs | 6 |
| Rotation direction | - | clockwise |

4.7.2 Hydraulic liquid distribution system

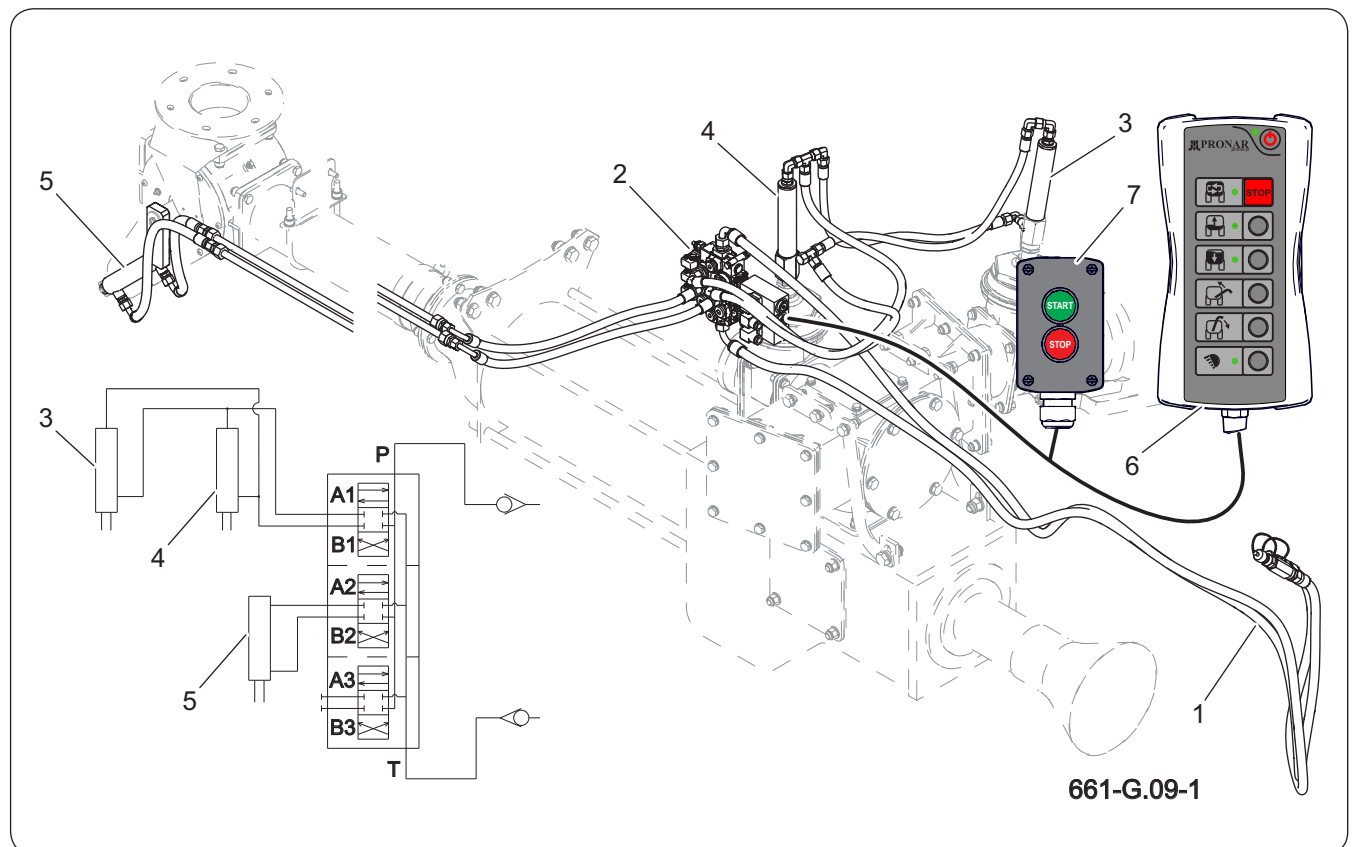
**Figure 4.9** Hydraulic liquid distribution system

- (1) hydraulic conduits (2) hydraulic distributor (3) suction slide actuator
 (4) tank gate valve actuator (5) three-way valve actuator (6) remote control
 (7) external remote control

ADVICE

The hydraulic system has been filled with L-HL32 Lotos hydraulic oil.

The individual functions of the machine are performed by means of a hydraulic distributor (2), whose individual sections are controlled by remote controls (6) and (7). The oil from the appropriate sections of the distributor goes to the next actuators of the gate valves. In this way, the functions of loading, mixing and



CAUTION

Connect the hydraulic hoses first. Then start the remote control, in the last step turn on the tractor's PTO drive.

unloading of the transported medium are performed.

BIZ.3.G-007.01.EN

4.8 DOCKING MECHANISM

4.8.1 Construction of the docking mechanism

ADVICE

The hydraulic system of the docking mechanism has been filled with L-HL32 Lotos hydraulic oil.



DANGER

Before driving, make sure that the docking mechanism is disconnected from the auxiliary suction hoses and folded to the transport (vertical) position.

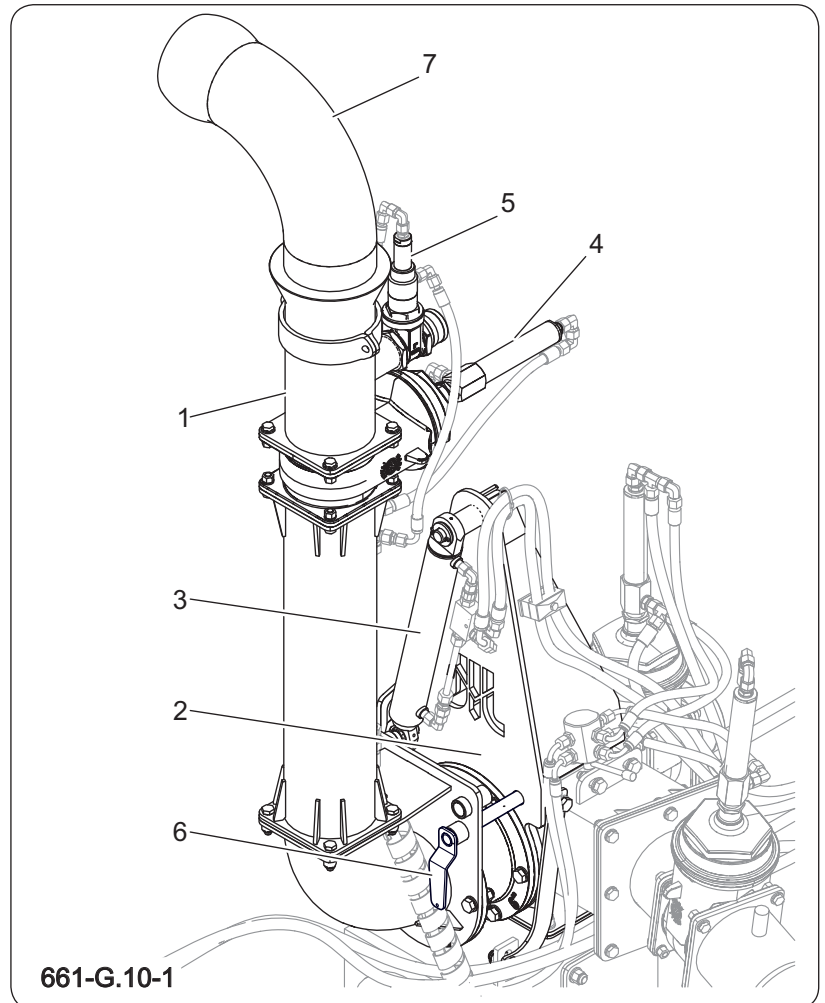

Figure 4.10 Construction of the docking mechanism

- | | |
|------------------------|------------------|
| (1) suction pipe | (2) mast |
| (3) hydraulic cylinder | (4) suction gate |
| (5) vent valve | (6) pin |
| (7) suction elbow | |

The docking mechanism is used to load the medium using the suction pipe (1) placed on the mast (2). Lowering and lifting is carried out by means of a hydraulic system operated from the remote control.

The design of the mechanism allows the medium to be sucked from the right or left side of the machine. Changing of the working side of the machine consists in changing the position of the actuator (3) in relation

to the mounting mast (2) and rotating the suction elbow (7).

The control of individual gate valves and the change of the position of the docking mechanism are described in the further part of the study. After finishing work, fold the docking mechanism and block its rotation with the pin (6).

4.8.2 Hydraulic system of the docking mechanism

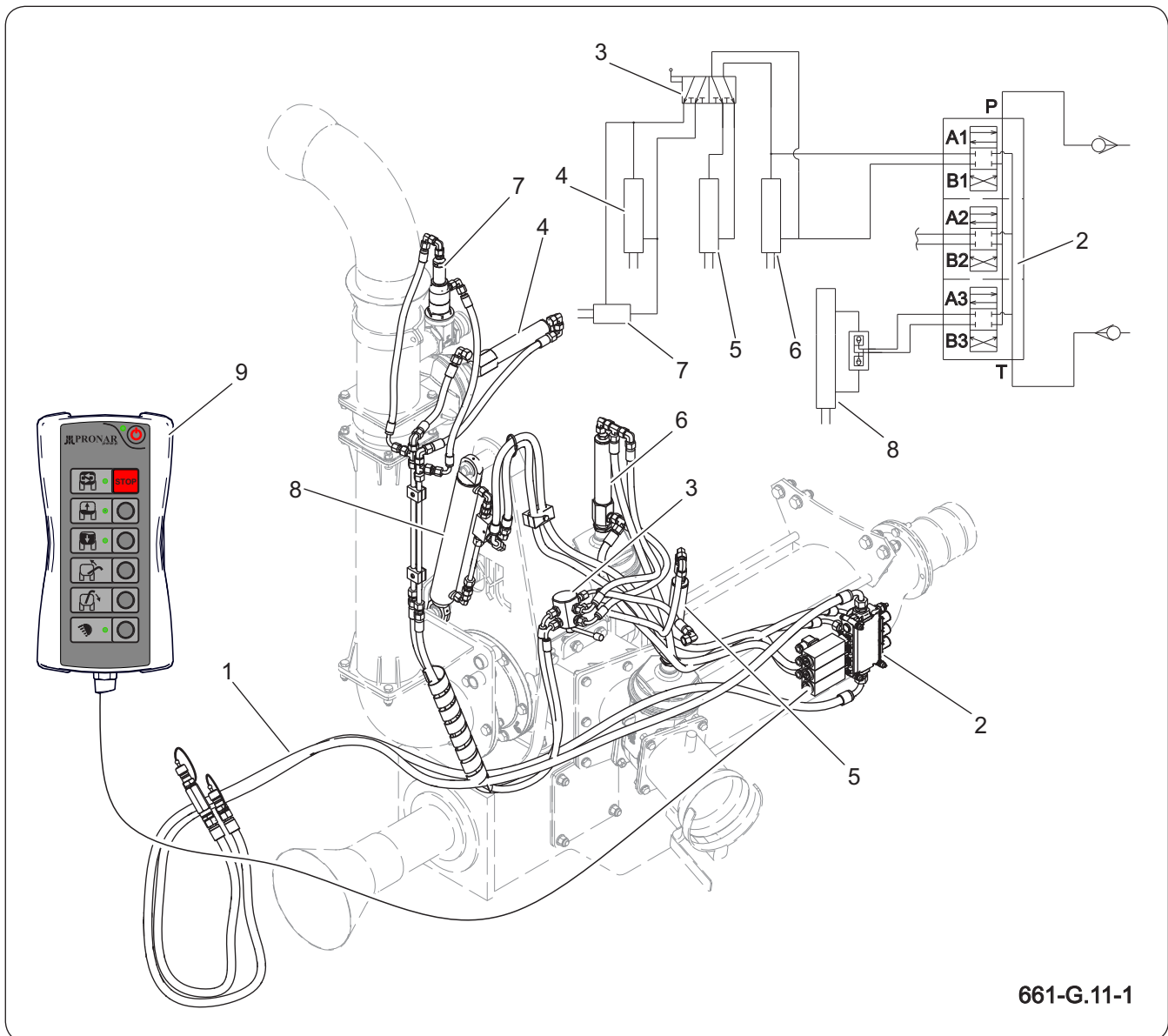

661-G.11-1

Figure 4.11 Hydraulic system of the docking mechanism

- | | | |
|--|-------------------------------------|-----------------|
| (1) hydraulic conduits | (2) hydraulic distributor | (3) 6-way valve |
| (4) docking latch actuator | (5) suction latch actuator | |
| (6) tank latch actuator | (7) docking mechanism vent actuator | |
| (8) cylinder lifting / lowering the docking mechanism tube | (9) remote control | |

The hydraulic oil is supplied through the hydraulic conduits (1) to the hydraulic distributor (2), which is controlled by the remote control (9). Individual work functions are performed by means of appropriate hydraulic gate valves. The valve (3) switches the side suction to the docking mechanism.

BIZ.3.G-008.01.EN

4.9 REAR HYDRAULIC OUTLETS

ADVICE

The hydraulic system has been filled with L-HL32 Lotos hydraulic oil.



DANGER

Depressurize the system before connecting the hydraulic hoses.

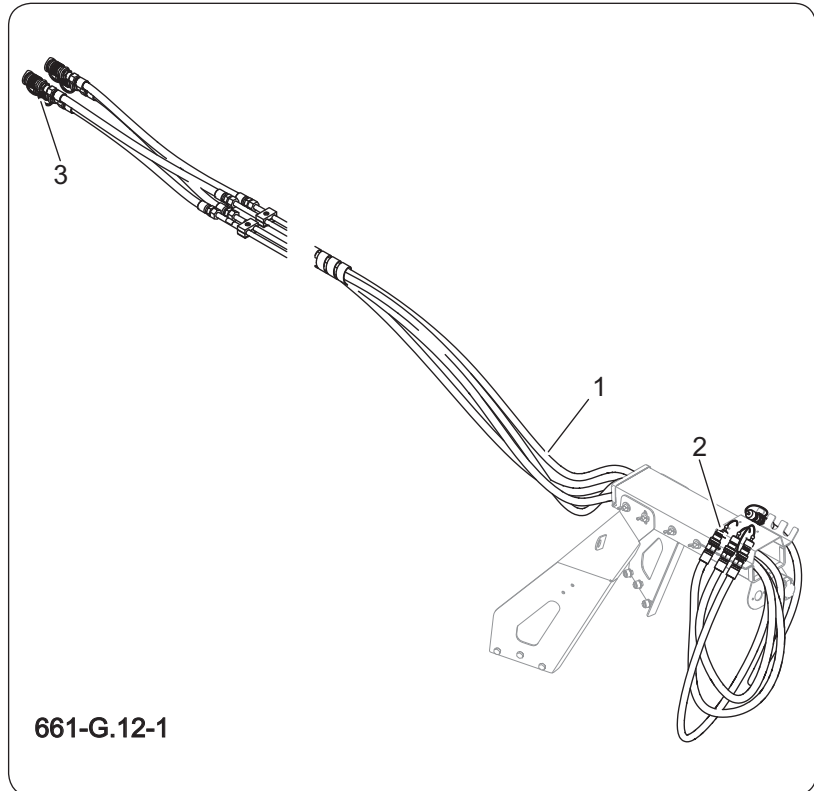

Figure 4.12 Rear hydraulic outlets

- (1) hydraulic hoses (2) hydraulic plug
(3) hydraulic socket

The machine can be equipped with additional hydraulic outputs to operate the car's accessories, e.g. applicators, sprinklers, etc. It is possible to place two hydraulic sections controlled from the agricultural tractor's external hydraulic manifold.

BIZ.3.G-009.01.EN

4.10 HYDRAULIC STEERING LOCK SYSTEM

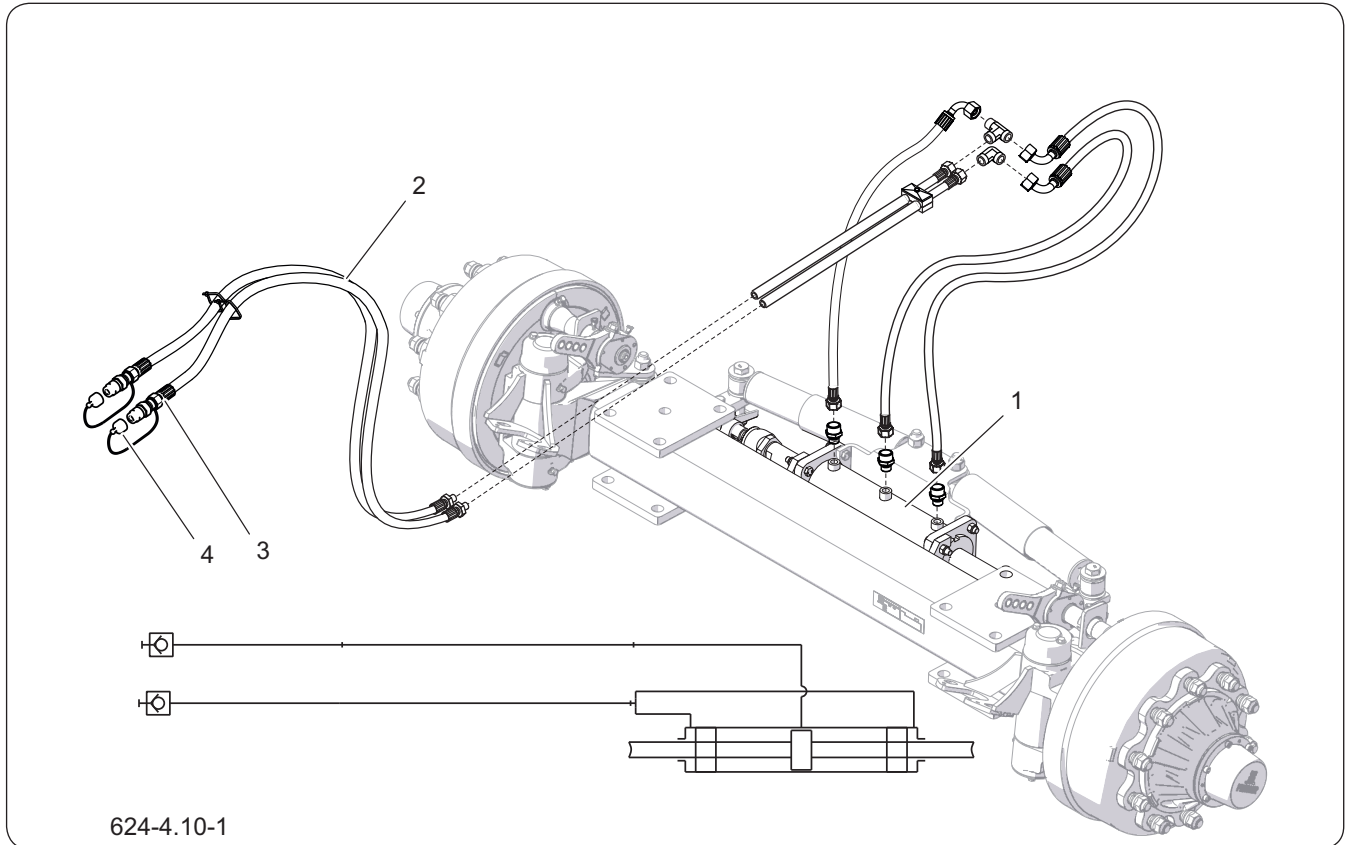

Figure 4.13 Construction and design of the hydraulic steering lock system
 (1) hydraulic actuator (2) hose (3) quick coupling plug

ADVICE

The hydraulic steering lock system was filled with L-HL32 Lotos hydraulic oil.

Easier off-road manoeuvring of the machine and less wear on the tyres will be achieved thanks to the released steering axle. When reversing, the axle knuckles must be locked, otherwise the machine will tend to turn left or right uncontrollably when reversing.

BIZ.3.G-010.01.EN



CAUTION

When moving a loaded machine at high speed, you must lock the torsion axle.

Lock the steering axle during reverse travel.

4.11 ELECTRICAL LIGHTING INSTALLATION

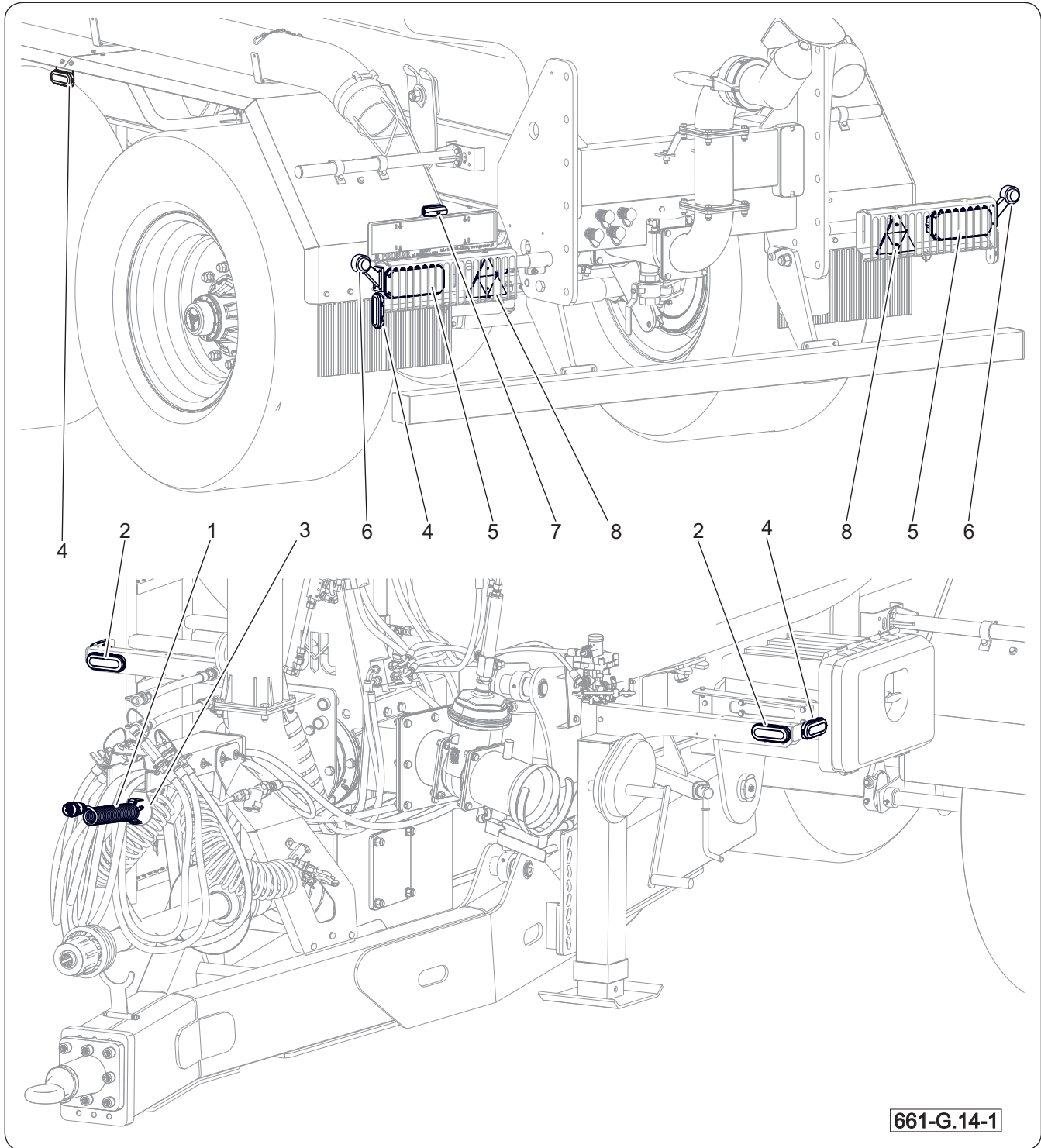

Figure 4.14 Arrangement of electrical system components and reflective elements

(1) 7 pin connection cable

(2) front position lamp

(3) 7 pin socket

(4) side marker lamp

(5) rear combination lamp

(6) rear marker lamp

(7) license plate lamp

(8) rear triangle reflector

The electrical lightning installation of the machine is adapted to be supplied from a DC source with

**CAUTION**

Before driving, check the operation and completeness of the electrical system.

Driving with faulty lighting installation is forbidden.

a voltage of 12V.

Connect the electrical system of the machine with the tractor using the connection cable (1) attached to the machine.

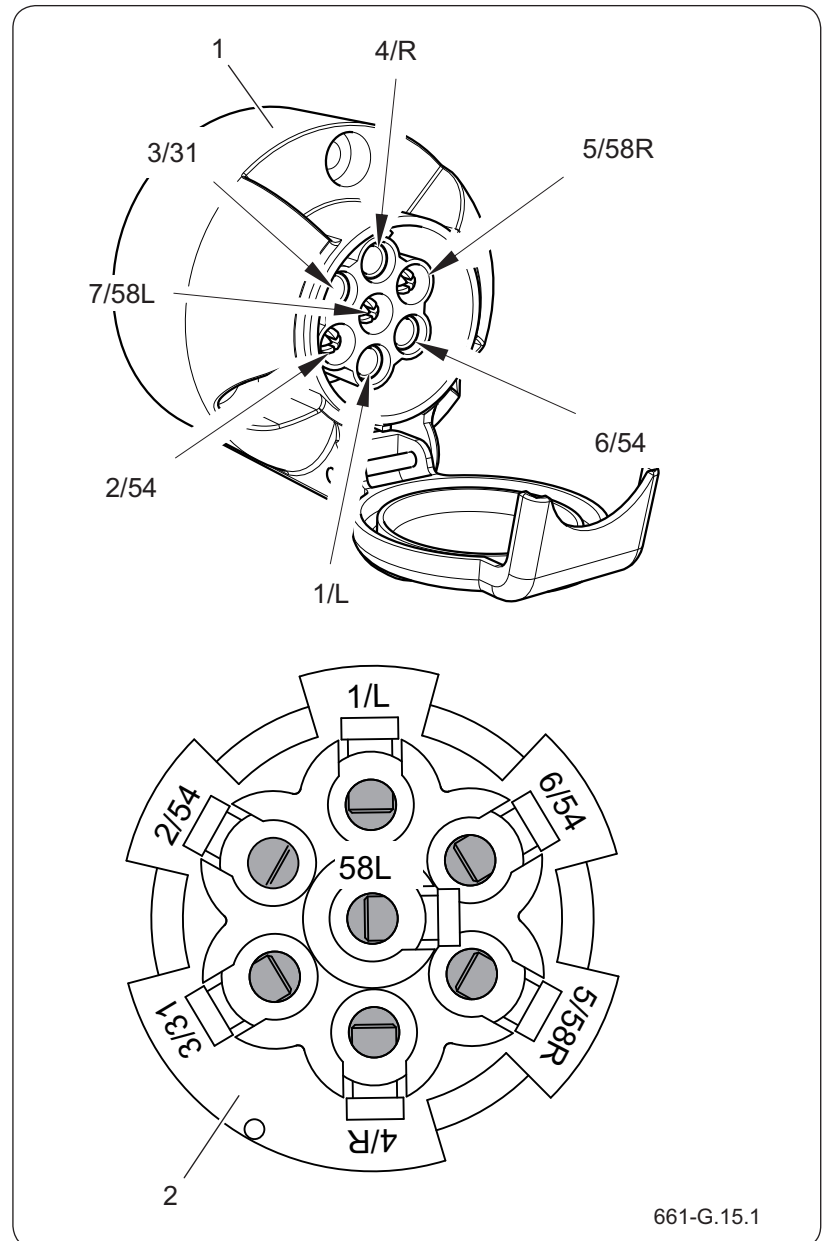

661-G.15.1

Figure 4.15 7 pin socket

(1) socket

(2) view from the beam side

Table 4.5 Connection markings for the connection socket

| Marking | Function (wire colour) |
|-------------------|-----------------------------------|
| 1/L | Left indicator (yellow) |
| 2/54 is cancelled | Not used |
| 3/31 is cancelled | Ground (white) |
| 4/R | Left indicator (yellow) |
| 5/58R | Rear right position light (brown) |
| 6/54 is cancelled | STOP light (red) |
| 58L | Left rear position lamp (black) |

BIZ.3.G-011.01.EN

Chapter 5

Correct use

PRONAR TG214

5.1 HEIGHT ADJUSTMENT OF THE DRAWBAR



DANGER

Use extreme caution when making adjustments due to the possibility of crushing limbs.



CAUTION

Regularly check the condition of the hitch pins and their protection. Pay attention to the condition of the drawbar linkage and its bolted connections. Lubricate the recommended lubrication points.

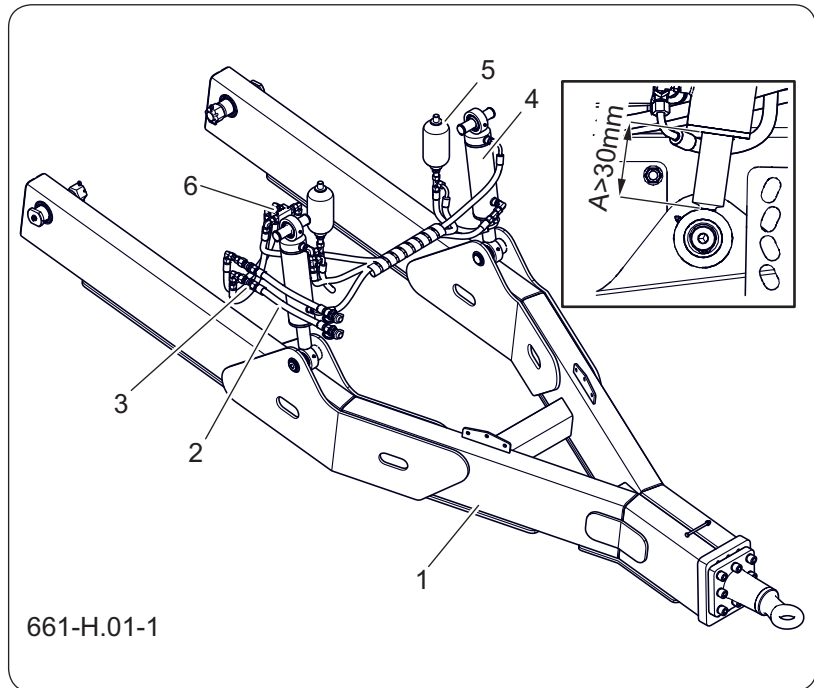

Figure 5.1 Height adjustment of the drawbar

- (1) drawbar
- (2) connecting hoses
- (3) quick coupling socket
- (4) sticker
- (5) hydraulic accumulator

Select the position of the drawbar individually according to the size of the machine's tyres, and according to the type and height of the hitch of the agricultural tractor with which the machine will be coupled. Adjust the height so that the machine is level when coupled to the tractor, which ensures that the weight of the machine is evenly distributed over the running axles.

Before adjusting, lock the slurry tanker with the parking brake, put the support wedges under the wheel of the rigid axle. Support the front of the machine frame so that the machine stands firmly. Fold the parking support into the transport position.

Adjusting the drawbar height

- Connect the hoses (2) to the quick couplings (3), then place the hose plugs in the appropriate section of the tractor's hydraulic distributor,
- Use the distributor lever to set the correct drawbar height.
- Check the distance between the piston rod eye and its housing - figure (5.1).

Due to the hydraulic cushioning of the hitch system and the stroke of the actuators, a clearance of $A > 30\text{mm}$ is required.

- Once the hitch height has been set, disconnect the hydraulic lines (2) and secure them with the covers.
- Place the protective caps on the quick couplings (3).

OBS.3.G-001.01.EN

5.2 HANDLING OF THE PARKING STAND

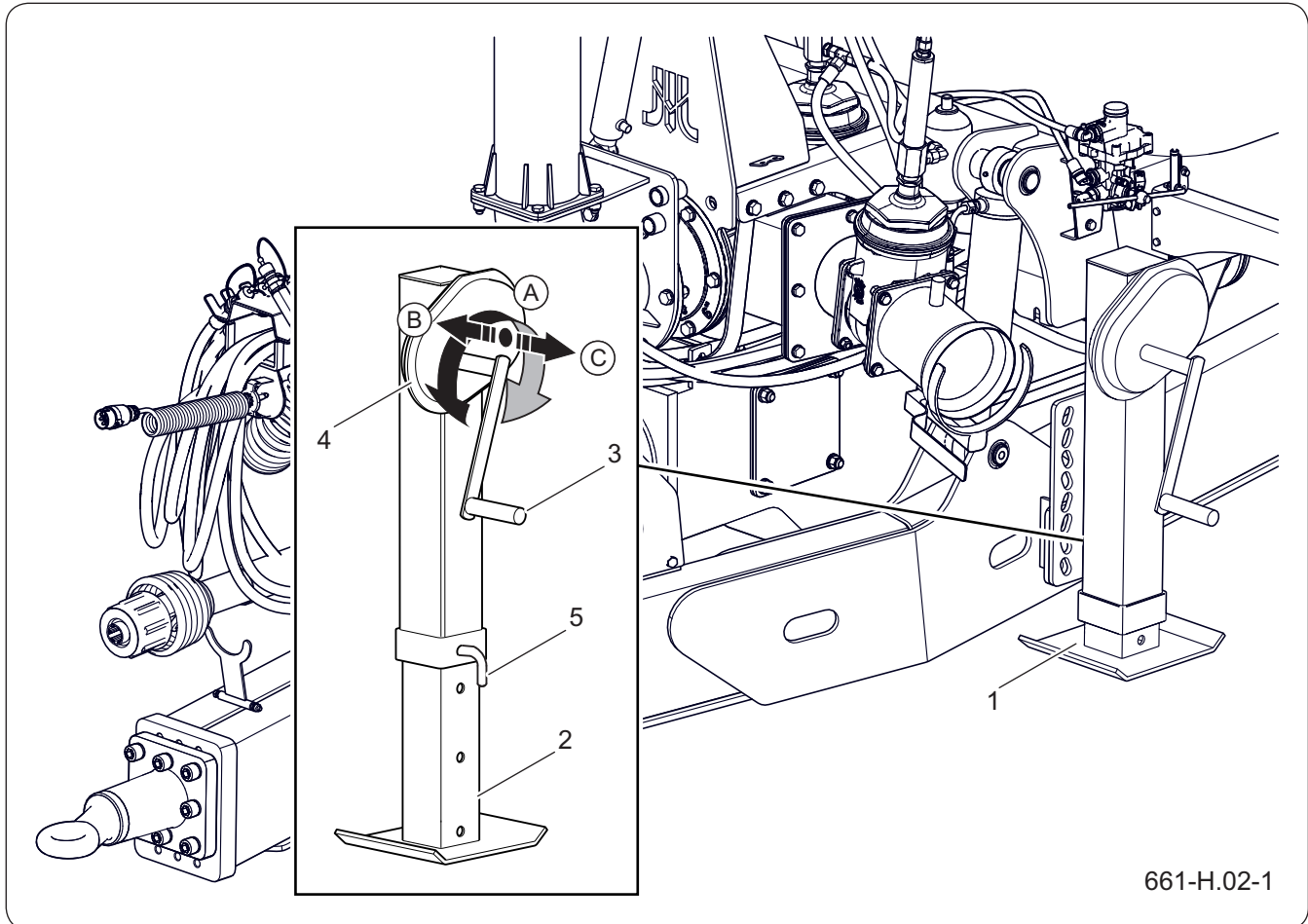

Figure 5.2 Telescopic stand

- | | | |
|---------------------|---------------------|----------------------|
| (1) stand | (2) foot | (3) crank |
| (4) gearbox | (5) securing pin | (A) neutral position |
| (B) 1st gear (slow) | (C) 2nd gear (fast) | |



DANGER

Take special care when operating the support - it also applies to bystanders or assistants.

Determining the correct height of the drawbar eye relative to the tractor's hitch can be achieved by means of a telescopic support with a mechanical transmission.

Use position (C) to quickly lower and raise the support foot. Position (C) is used to lower and raise the unladen machine. In position (B), the support foot (2) extends more slowly and you do not need to apply much force to raise the machine.

**CAUTION**

It is forbidden to start and drive with the support lowered.

Before driving, make sure that the support is fully raised and the crank is in the neutral position (A). Be sure to secure the support foot with the safety pin.

Lifting up of the support

- Remove the pin (5).
- Move the crank (3) of the support from neutral (A) to position (B) - slowly.
- By turning the crank counterclockwise, raise the support foot (2) as far as possible.
- Put on the safety pin (5), turn the crank to the neutral position (A).

Lowering of the support

- Remove the pin (5).
- Move the crank (3) of the support from the neutral position (A) to the position (B) - slow or (C) fast.
- By turning the crank clockwise, lower the support to the ground or adjust the height of the hitch in relation to the hitch (if the machine is to be hitched to a tractor).
- Put on the safety pin (5), turn the crank to the neutral position (A).

OBS.3.G-002.01.EN

5.3 COUPLING AND UNCOUPLING OF THE MACHINE

5.3.1 Coupling of the machine



CAUTION

After connecting the machine but before starting to drive, carry out a daily inspection of the machine.

An external inspection of the machine without connecting it to the tractor will not make it possible to verify its technical condition.

You can connect the machine to an agricultural tractor if all the connections (electric, pneumatic, hydraulic) on the tractor comply with the machine manufacturer's requirements as indicated in the Agricultural Tractor Requirements table.

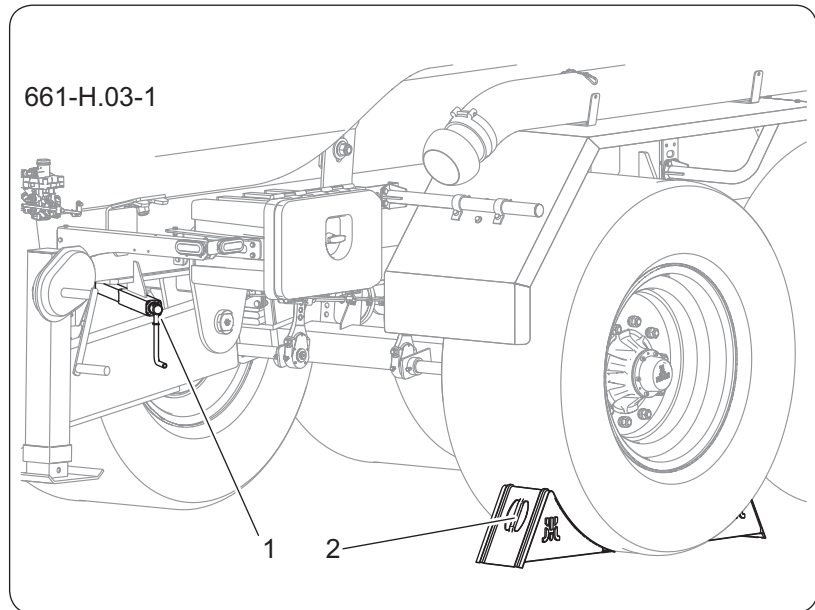

Figure 5.3 Parking brake

(1) parking brake

(2) support wedges

Preparation

- Make sure the machine is immobilised with the parking brake.
Turn the brake mechanism (1) clockwise as far as it will go.
- Make sure you place the locking chocks (2) under the trailer wheel.
- Position the agricultural tractor in front of the drawbar linkage.

**DANGER**

No bystanders are allowed between the machine and the tractor during coupling. The operator of the agricultural tractor, when coupling the machine, should ensure that no bystanders are in the danger zone during coupling.

Take special care when connecting the machine.

Ensure adequate visibility when coupling.

Once the coupling is complete, check the pin hitch protection.

Height adjustment of the trailer drawbar

- Use the parking stand to set the correct height of the drawbar linkage in relation to the hitch of the aggregated agricultural tractor. Follow the *Handling the support* section.

Height adjustment of the drawbar

- Adjust the height of the drawbar using the parking support with mechanical transmission; the height is changed using the support transmission—see *Mechanical support*.

Connecting the machine to the tractor hitch

Figure 5.4 Drawbar linkage protection

(1) swivel link

(2) ball link

(3) chain

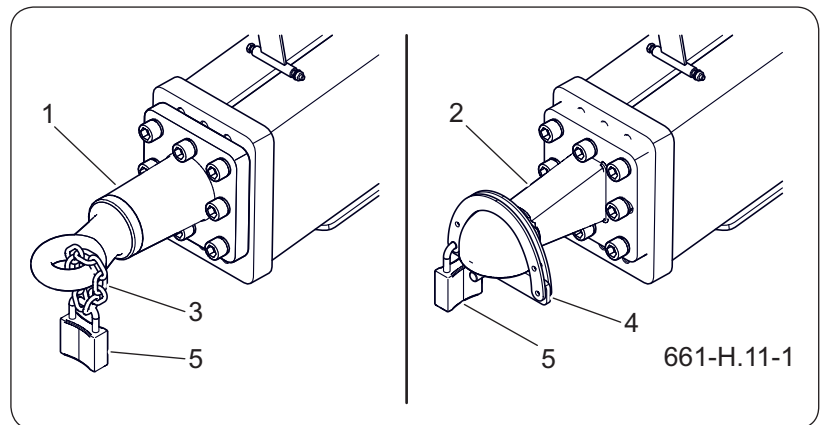
(5) padlock

(4) protection

**CAUTION**

If the machine is parked for a long time, the air pressure in the air brake system may not be sufficient to release the brake shoes. In this case, after starting the tractor and air compressor, wait until the air in the air system tank has been replenished.

- Dismantle the linkage protection.
Unfasten the padlock (5) and unfasten the chain (3) or safety device (4).
- Reverse the tractor and connect the machine to the appropriate hitch.
- Check the coupling protection protecting the machine from accidental disconnection.
- If an automatic coupling is used on the tractor, make sure that the aggregation operation is completed and the drawbar linkage is secured.
- Move the parking support to the transport



CAUTION

When connecting the pneumatic lines of a two-wire system, first connect the line marked yellow and then the line marked red.

position.

- Turn off the tractor engine and remove the ignition key. Secure the tractor with the parking brake. Secure the tractor cab against unauthorised access.

Connecting of the brake system

- Connect the hoses of the pneumatic system.
First connect the plug marked yellow to the yellow socket on the tractor and then the plug marked red to the red socket on the tractor. When the second line is connected, the brake release system will switch to

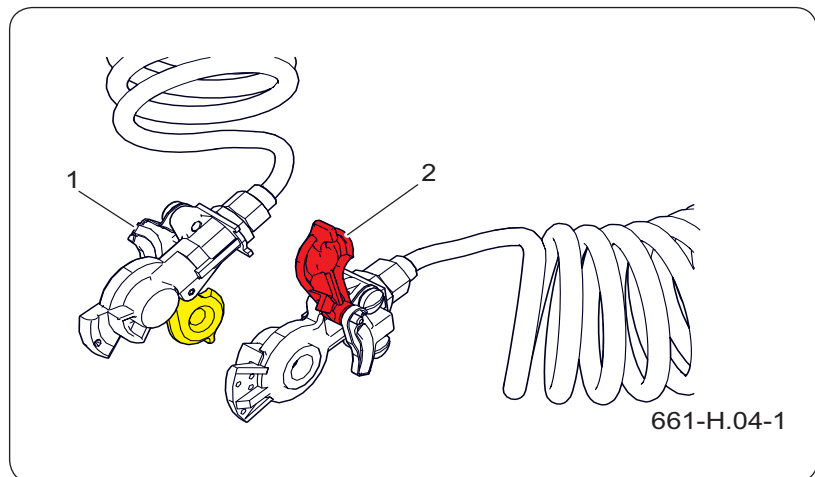

Figure 5.5 Air brake lines

(1) yellow plug

(2) red plug



DANGER

Driving with a faulty or defective hydraulic system is prohibited.

Take special care, the hydraulic system may be under high pressure.

normal operation (disconnecting or interrupting the air lines causes the machine control valve to automatically switch to the position that activates the machine brakes).

- If the brakes do not respond when the air lines are connected, this may indicate low air pressure in the reservoir. The air in the tank needs to be topped up to the correct pressure for the system to become operational.

**DANGER**

It is forbidden to use a faulty machine.

**CAUTION**

The original PTO manufacturer's operating manual is supplied with the PTO, which describes all maintenance operations for the product supplied.

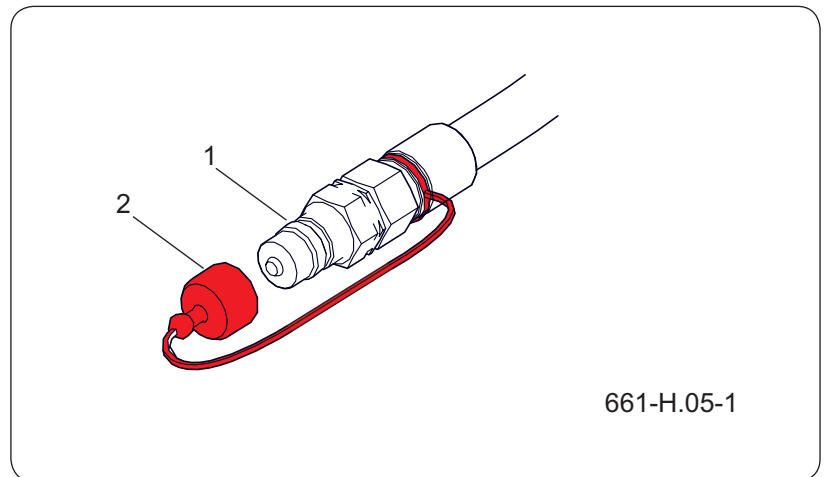

Figure 5.6 Plumbing connection
(1) hydraulic plug (2) cap

Connecting of the hydraulic system

Depending on how the machine is assembled, connect the hydraulic system connections to the corresponding sockets on the tractor.

- Connect the hydraulic system couplings marked with red plugs.
- If necessary, connect the hydraulic lines of the additional rear outlets, the pairs of which are marked with yellow and blue plugs
- Connect the hoses of the hydraulic steering lock installation marked with green plugs.

PTO power take-off connection.

The liquid distribution system is an independent installation driven by the PTO shaft of the agricultural tractor.

- Connect the pre-matched shaft to the PTO of the agricultural tractor.
- Check the shaft covers and the condition of the fixing chains.
- Connect the 3-pin cable, place the remote control in the tractor cab - Figure(5.8).

Set the PTO speed of the agricultural tractor to 540 rpm



CAUTION

When coupling is complete, secure the hoses of the hydraulic, brake and electrical systems so that they do not become entangled in moving parts of the agricultural tractor while driving and are not liable to kink or cut when turning.



DANGER

Take extra care when uncoupling the trailer from the tractor.

Ensure good visibility. Ensure that no one is between the trailer and the tractor.

Before disconnecting the cables, shaft and drawbar linkage, close the tractor cab and secure it against unauthorised access. Switch off the tractor engine.



CAUTION

When disconnecting the pneumatic hoses of a two-wire system, disconnect the red-coloured hose first and then the yellow-coloured hose.

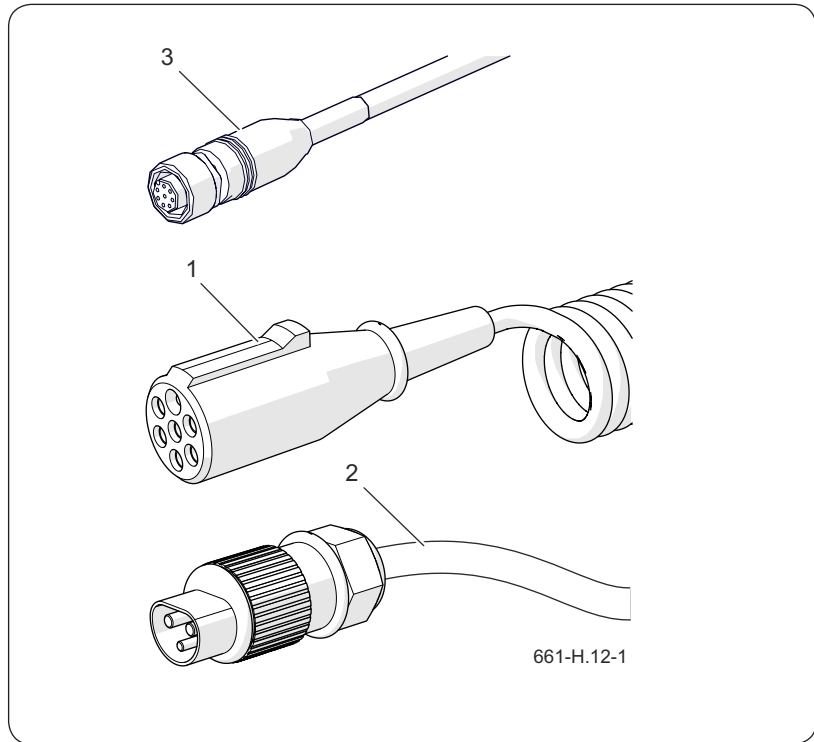

Figure 5.7 Electrical connection

- (1) 7-pin cable
- (2) 3-pin cable
- (3) remote control cable

Connection of electrical lighting installation.

- Connect the main cable (1) supplying the lighting wiring (7-pin).
- If the tractor does not have such sockets, or if the sockets are of a different type, have them fitted by qualified persons in accordance with the tractor manufacturer's recommendations.

Additional information

- Check that connected cables do not become entangled in moving parts of the tractor or machine during operation. If necessary, secure the connection.
- Carry out a daily inspection of the machine.
- If the machine is operational, you can proceed.
- Immediately before starting to drive, remove the wheel chocks and release the parking brake on the machine.

Turn the crank of the brake mechanism

counterclockwise as far as it will go.

5.3.2 Disconnecting of the trailer



CAUTION

Always secure the uncoupled machine against unauthorised use by attaching a linkage protection device.

- Place the machine on a hard and flat surface.
- Switch off the tractor engine and remove the ignition key, secure the tractor with the parking brake.
- Lower the support to the parking position.
- Immobilise the machine with the parking brake.
- Place locking chocks under one wheel of the machine's rigid axle, one at the rear and one at the front of the wheel.
- Disconnect all the hoses one by one, securing the ends by putting plugs on the hydraulic connectors.
- Place the cables on the cable support.
- Disconnect the power take-off.
- Unhook the linkage hitch, start the tractor and drive it away.
- Fit the drawbar linkage protection.

OBS.3.G-003.01.EN

5.4 LOADING



DANGER

It is forbidden to transport people and animals.



CAUTION

It is forbidden to exceed the permissible load capacity of the machine, as it threatens safety while driving and may cause serious damage.



CAUTION

Dry operation of the screw pump is unacceptable and leads to the destruction of the device.

Always check that the pump is filled with liquid before starting work.

Pumping medium into a closed line / gate valve will irreparably damage the pump.

Freezing temperatures will damage the pump, empty the device when the device is not in use during the freezing temperature period.

Load the machine when the septic tanker is connected to the tractor and placed on level ground.

Before loading, check that the 3-way gate valve is closed. Check whether the cavitation pump is flooded - it is unacceptable to run it "dry". Check the setting of the gate valves before starting the pump. Check the patency of the vent line. Inspect the tank carefully for leaks and damage. Any leak disqualifies the machine from further operation.

The septic tanker is designed for work related to the transport, pumping and spreading of liquid substances such as slurry, water (not intended for food purposes), municipal sewage and clarified sludge.

The use of loads other than those intended by the Manufacturer is prohibited.

Due different density of materials, the use of the total capacity of the load area may exceed the allowable capacity of the machine.

Suction of the medium

A well-mixed medium free of foreign particles should be sucked up. Solid impurities, stones, etc. will damage the cavitation pump, so use suitable suction hoses with inlet protection.

The cavitation (screw) pressure pump cannot work without the medium, before starting work, flood the pump with water. If there is a risk of temperatures below zero and freezing of the medium, there is a possibility of damage to the pump. Drain the pump. You cannot pump the medium into the closed pipe, the pump will fail. Always check that the discharge line is open before starting the pump.

5.4.1 Loading via suction connection (left or right)

Load the machine by performing the following steps:

- Set the tractor with the machine to drive

**DANGER**

When loading of the machine, the drawbar eye and the tractor hitch are subjected to high vertical loads.

**DANGER**

The transported load must be protected against spillage and contamination of the road during the journey. If the septic tanker is not sealed, it is forbidden to use it.

**DANGER**

When working with slurry, pay attention to adequate ventilation of places where loading work is carried out. Use forced ventilation in confined spaces.

During loading and unloading, harmful gases such as carbon dioxide, ammonia, hydrogen sulphide and methane may be released.

Escaping gases are poisonous and explosive.

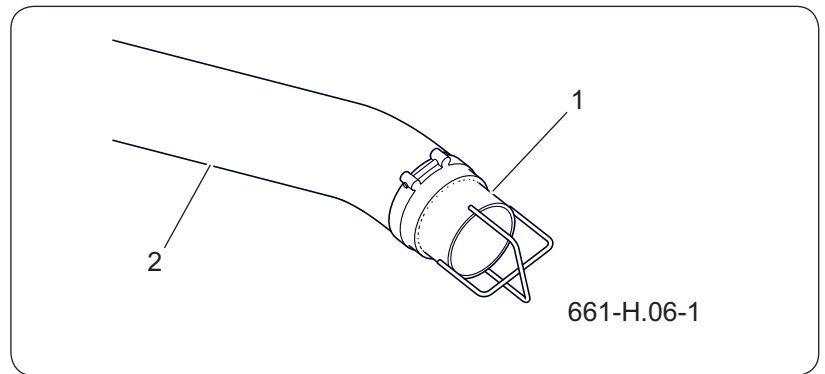
**Figure 5.8** Suction line

(1) cover (2)

6" suction hose

straight ahead on flat, stable and hard ground as close as possible to the place of loading.

- Immobilize the set with parking brake.
- Connect the appropriate hose to the suction valve stub (4). Make sure that the valve (7) is in position (B) - closed.
- Start the remote control and select the tank filling option, hold the button for about 2 seconds.

Side suction valve (4) open

Closed tank gate valve (5)

Three-way valve - mixing

- Make sure there are no bystanders near the PTO shaft. Engage the tractor's PTO drive.

The pump starts pumping the medium

- On the remote control, press the STOP button or wait until the filling indicator (8) indicates the full tank level and automatically closes the suction gate valve (4). The pump (1) is still working and mixing is taking place in the tank (the diode of the mixing button is on).

Closed side suction gate valve (4)

Open tank gate (5)

Three-way valve - mixing

- Disengage the tractor's PTO drive.
- Open the valve (7) - position (A) - wait for

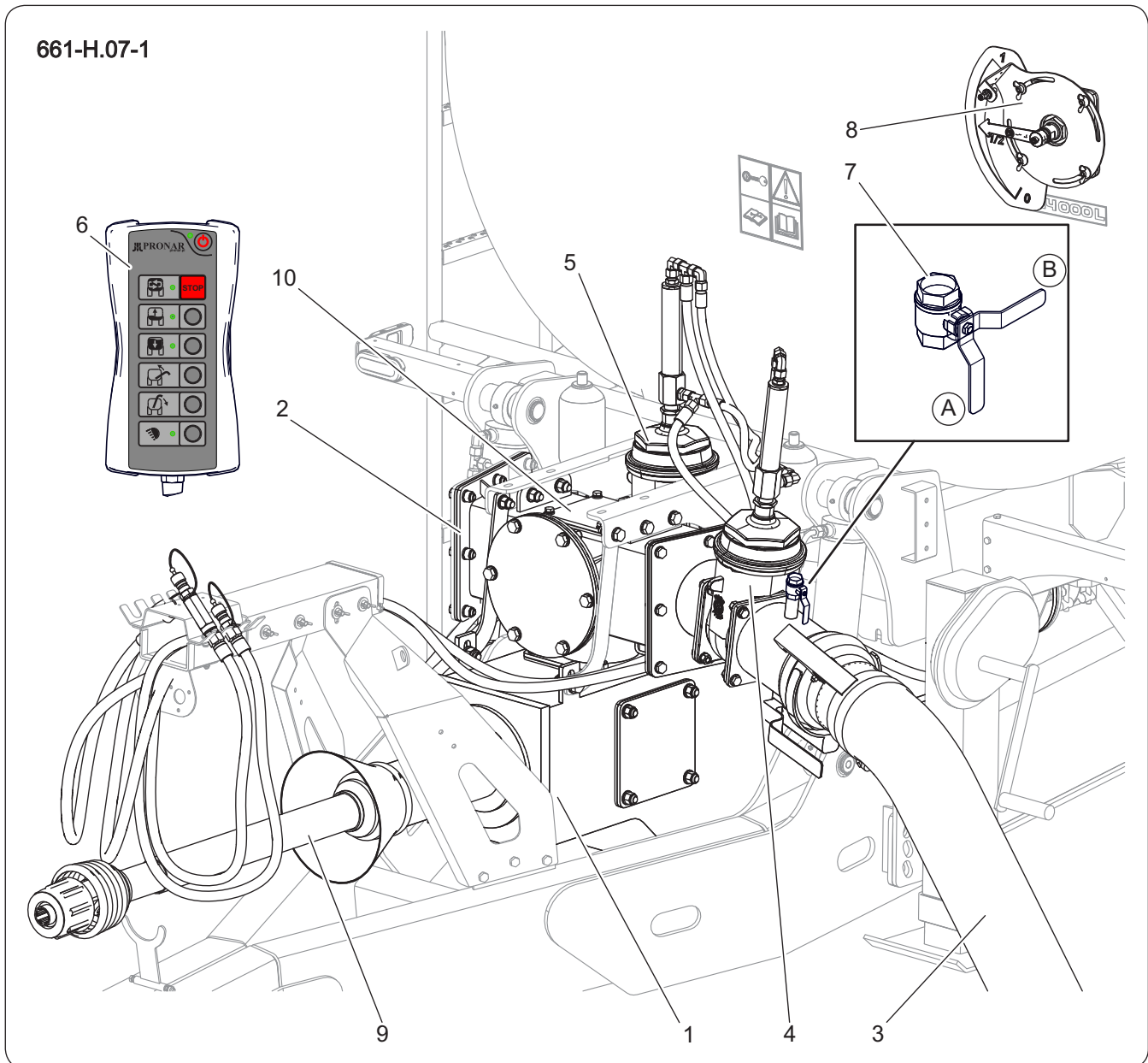

Figure 5.9 Loading side connection

- | | | |
|------------------------|------------------------|---------------------|
| (1) screw pump | (2) suction connection | (3) hose |
| (4) suction gate valve | (5) tank gate valve | (6) remote control |
| (7) valve | (8) filling indicator | (9) PTO shaft |
| (10) pump priming flap | (A) open position | (B) closed position |

a moment until the liquid column in the hose (3) drops to the tank, disassemble the hose and place it in the appropriate holder.

5.4.2 Loading via docking system (left or right)

The additional equipment of the machine is a docking mechanism that you can use interchangeably with the side suction connector.

- Set the tractor with the machine to drive straight ahead on flat, stable and hard ground at the place of loading.
- Immobilize the set with parking brake.
- For loading with the docking mechanism,

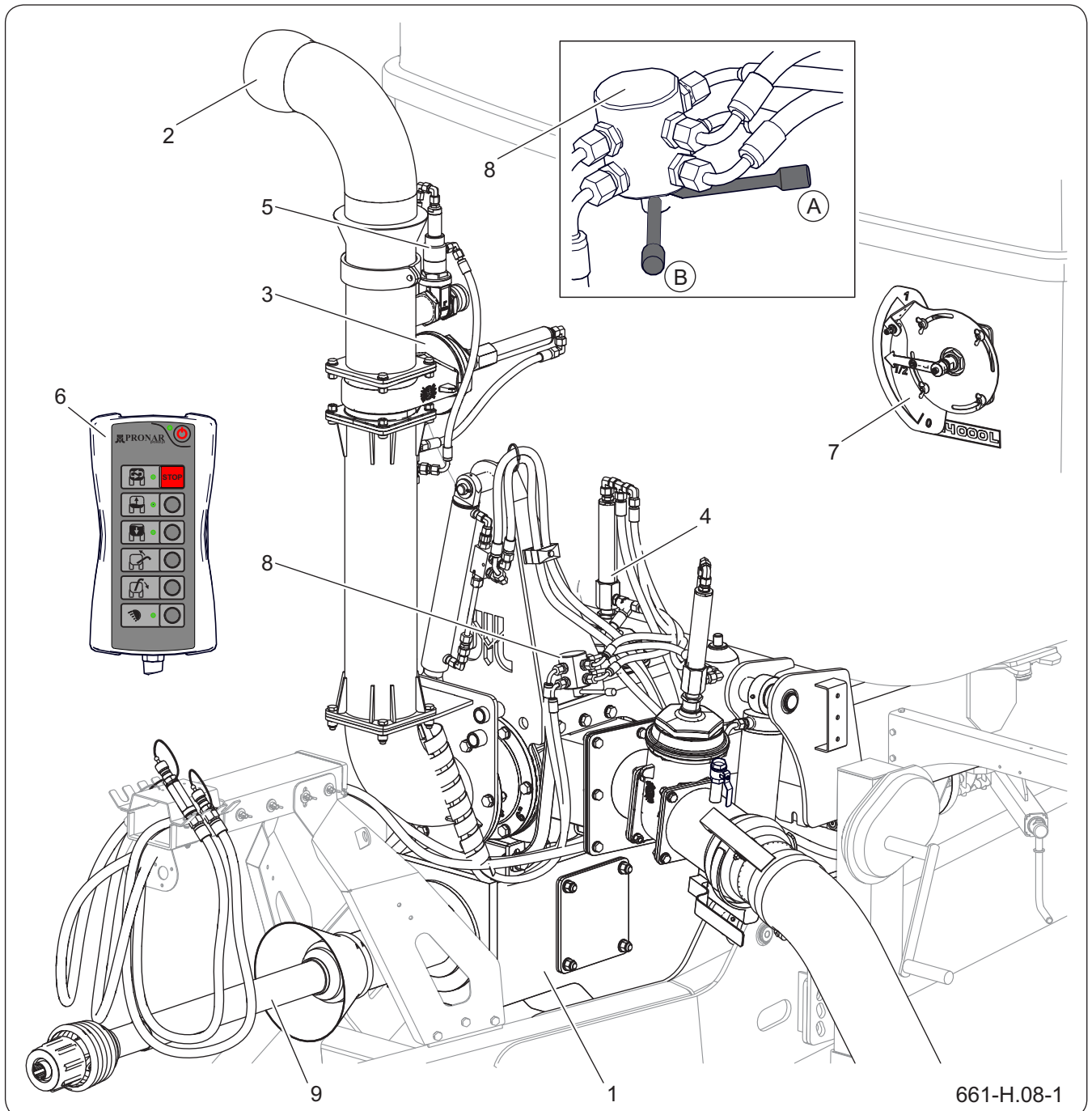

661-H.08-1

Figure 5.10 Loading docking mechanism

- | | | |
|-----------------------|-------------------------------|------------------------|
| (1) screw pump | (2) suction connection | (3) suction gate valve |
| (4) tank gate valve | (5) vent valve | (6) remote control |
| (7) filling indicator | (8) hydraulic distributor | (9) PTO shaft |
| (A) side loading | (B) loading docking mechanism | |



DANGER

During loading work, it is necessary to use additional personal protective equipment (masks, rubber gloves, etc.).



DANGER

Make sure that there are no bystanders in the unloading / loading area. Before unloading, take care of adequate visibility and make sure that there are no bystanders in the vicinity.

move the divider (8) to position (B).

- Use the remote control (6) to lower the suction connection (2). Make sure that the suction pipe (2) fits the tank connection from which the material will be taken. The tightness of the connection is a key factor affecting the speed of loading.

- Using the remote control, select the tank filling option, hold the button for about 2 seconds.

Suction valve open (3)

Closed tank gate valve (4)

Three-way valve - mixing

- Make sure there are no bystanders near the PTO shaft. Engage the tractor's PTO drive.

The pump starts pumping the medium

- On the remote control, press the STOP button or wait until the filling indicator (7) indicates the full tank level and automatically closes the suction gate valve (3). The pump (1) is still working and mixing is taking place in the tank (the diode of the mixing button is on).

Suction valve closed (3)

Open tank gate (4)

Open venting gate (5)

Three-way valve - mixing

- Using the appropriate button on the remote control (6), raise the docking arm to the transport position.
- Disengage the tractor's PTO drive.
- Secure the rotation of the docking mechanism with the pin.

OBS.3.G-004.01.EN

5.5 TRANSPORT



CAUTION

Always use the agitation option when transporting a medium with a high solids content or when transporting material in freezing temperatures.



CAUTION

Refer to the drive shaft manual attached to the machine, check the maximum angle of inclination of the rotating shaft. Exceeding the permissible shaft deflection may damage it.

When driving comply with traffic regulations, be prudent and considerate. The most important guidelines for steering a tractor with a machine attached are presented below.

- Before moving make sure that there are no bystanders, especially children, near the machine and tractor. Ensure proper visibility.
- Make sure that the machine is correctly connected to the tractor and tractor's hitch is properly secured.
- You cannot drive on public roads with the docking mechanism pipe extended, always put the mechanism in the transport position.
- If mixing of the transported medium is not required; disengage the PTO drive.
- Vertical load carried by the machine drawbar eye affects the steering of the agricultural tractor.
- Do not overload the machine. Exceeding the permissible load capacity of the vehicle is prohibited and may damage the machine. Overloading is a road travel hazard for the tractor and machine operator or other road users.
- The permissible design speed and speed resulting from restrictions on road traffic regulations must not be exceeded. The travel speed should be adjusted to the prevailing road conditions, machine load condition, type of load carried and other conditions.
- If you disconnect the machine from the tractor, you must secure it by blocking it with the parking brake and placing wedges under the wheels. It is forbidden to park a loaded machine supported only by a parking stand.
- The tractor operator is required to equip the



CAUTION

It is prohibited to leave the machine unsecured.

In the event of a machine breakdown, stop at the side of the road without endangering other road users and mark the stopping place in accordance with traffic regulations.

machine with an attested or approved warning reflective triangle.

- When travelling on public roads, mark the machine with a slow-moving vehicle sign.
- While driving, obey the rules of the road, signal the change of direction by means of direction indicators, keep clean and take care of the technical condition of the lighting and signalling installation.
- Damaged or lost lighting and signalling components must be repaired or replaced immediately.
- Avoid ruts, depressions, ditches, or driving along roadside slopes. Driving across such obstacles can cause the machine and tractor to tilt suddenly. This is especially important because the centre of gravity of a laden machine adversely affects driving safety. Driving near the edges of ditches or channels is dangerous due to the risk of landslides under the wheels of the machine or tractor.
- Reduce speed before cornering, when driving on uneven or sloping terrain.
- When driving, avoid sharp turns, especially on slopes.
- It should be remembered that the braking distance of the set increases significantly with the increase in the weight of the transported load and the increase in speed.
- Control the behaviour of the machine while driving on uneven terrain. Adjust speed to terrain and road conditions.
- The machine is adapted for driving on slopes up to a maximum of 8°.



CAUTION

Travel with a load through ruts, ditches, slopes, etc. poses a high risk of overturning the machine. Be especially careful.

Moving the machine on steeper slopes may cause the vehicle to overturn due to loss of stability. Prolonged driving on slopes creates the risk of losing braking efficiency.

OBS.3.G-005.01.EN

5.6 UNLOADING



DANGER

Make sure that no one is near the spilled load during unloading.

Before starting the PTO drive, make sure that there are no people or objects near the shaft that may become entangled in the rotating mechanism.

The unloading of the transported medium is possible only through the rear spigot located behind the three-way gate valve. The standard equipment of the machine is a spreader.

Unload the machine by following steps below:

- Start the remote control and select the option to empty the tank, hold the button for about 2 seconds.

Suction valve closed

Tank gate valve open

Three-way valve - ejection

- Make sure there are no bystanders near the PTO shaft. Engage the tractor's PTO drive.

The pump starts pumping the medium

- When the tank is empty, press the STOP button on the remote control.

Suction valve closed

Tank gate valve open

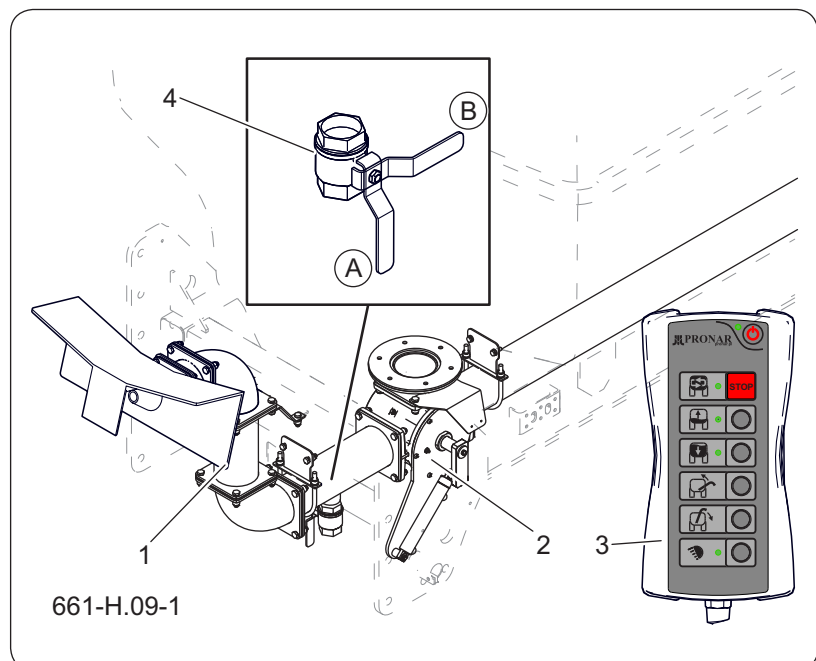

Figure 5.11 Unloading system

- | | |
|--------------------|--------------------------|
| (1) spreader | (2) three-way gate valve |
| (3) remote control | (4) drain valve |
| (A) open position | (B) closed position |



CAUTION

When using spraying devices when unloading, pay attention to whether there are any unauthorized persons in the unloading area. Watch out for overhead power lines.

Three-way valve - mixing

- Disengage the tractor's PTO drive.

OBS.3.G-006.01.EN

5.7 FEED PUMP



DANGER

The pump may only be operated with the power take-off shaft disengaged.

The pumped medium must not exceed the temperature of 50°C, the temperature increase above this value may lead to seizing of the pump impeller.



CAUTION

A single impeller screw pump cannot run dry - running dry can damage the stator.

Before starting the machine for the first time or after a long standstill of the machine, fill the pump with water.

Pay attention to the direction and value of rotation of the PTO shaft; the pump runs at 540 rpm in a clockwise direction.

If there is a risk of freezing temperatures, empty the pump of liquid.

Pumping of media into a closed line will damage the pump, check the hoses for obstruction before starting the pump.

ADVICE

Purge the pump using the suction port flap - see figure (5.8)

The screw pump, driven by the tractor's PTO shaft, pumps the medium depending on the setting of individual gate valves.

When sucking in the medium, always use hose covers that prevent large solid impurities, e.g. stones, from entering the pump chamber. Check and clean the pump chamber (1) regularly. Check and replace the oil in the pump gear (2) according to the inspection schedule.

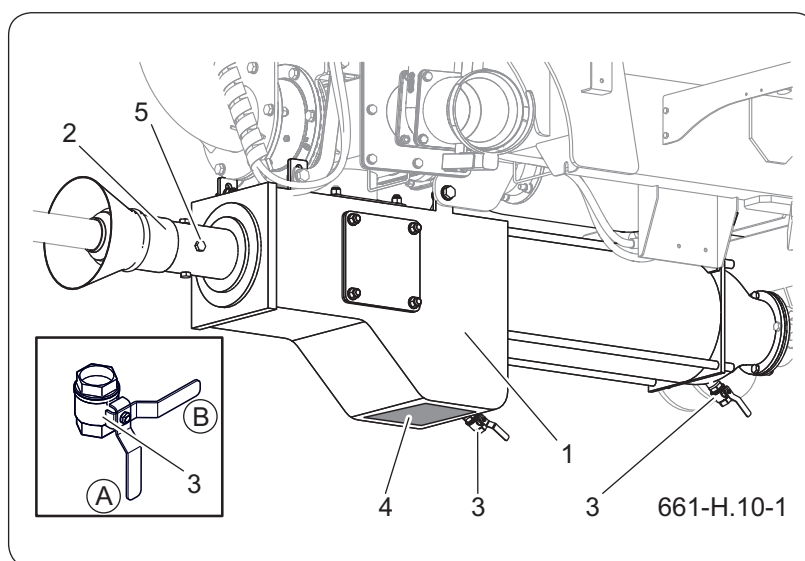

Figure 5.12 Feed pump

- | | |
|-----------------------|---------------------|
| (1) discharge chamber | (2) gear |
| (3) valve | (4) flap |
| (5) inspection plugs | (A) open position |
| | (B) closed position |

Make sure that the discharge chamber of the pump (1) is filled with the medium before starting work and that the discharge line is open; operation of the pump without medium will lead to serious failure. Before starting work, check if the drain valves (3) of the pump are closed, the bottom flap (4) must be tightly closed. Any leakage of the pumping system disqualifies the machine from operation.

OBS.3.G-007.01.EN

5.8 RULES FOR THE USE OF TIRES

- When working with tires, the machine should be secured against rolling by placing chocks under the wheels. Wheels can be taken off only when the machine is not loaded.
- Repair work on wheels or tires should be performed by persons trained and authorized for this purpose. These works should be performed with the use of appropriately selected tools.
- Checking the tightening of the wheel nuts carry out after the first use of the machine, every 2- 3 hours during the first month of using the machine, and then every 30 hours of driving. Always repeat all operations if the wheel was disassembled. Wheel nuts should be tightened in accordance with the recommendations contained in the *Inspections and technical service* chapter.
- Regularly check and maintain proper tire pressure as recommended in the instructions (especially after a long break in the machine use).
- Tire pressure should also be checked during all-day intensive work. Take into account that an increase in tire temperature can increase the pressure by up to 1 bar. With this increase in temperature and pressure, reduce the load or speed of the machine.
- Never reduce the pressure by venting if it increases due to temperature.
- Valves must be secured with appropriate caps to avoid soiling.
- Do not exceed the machine speed limit.
- During the whole day cycle, take a minimum of one hour break at noon.

- Observe 30 minutes breaks for cooling the tires after driving 75 km or after 150 minutes of continuous driving, whichever comes first.
- Avoid damaged surfaces, sudden and variable manoeuvres, and high speeds when turning.

OBS.3.G-008.01.EN

5.9 CLEANING



DANGER

Refer to the instructions for using cleaning detergents and preservatives.

When washing with detergents, wear suitable protective clothing and eye protection.

When cleaning the machine and staying on the tank, the tractor engine must be turned off, the articulated telescopic shaft must be disconnected.

Every day, after work finishing, thoroughly clean the machine of the remains of the transported material. If you use a pressure washer, learn about the principle of operation and recommendations for safe operation of this device.

Guidelines for cleaning of the machine

- Stop the tractor and the machine on a flat, even surface.
- Turn off the tractor engine and remove the ignition key.
- Secure the machine and tractor with the parking brake, place wedges under the manure spreader wheel.
- Secure the tractor against unauthorized persons.
- On the outside, wash the machine with a strong jet of water and leave it to dry in a dry and ventilated place.

The use of pressure washers increases the effectiveness of washing, but particular care should be taken during work. While washing, do not put the nozzle of the cleaning aggregate closer than 50 cm from the surface to be cleaned.

The water temperature should not exceed 55 °C.

During washing with too high pressure, the paint may be damaged.

- Fill the inside of the tank with water. By moving and braking the set, the water will clean the inside of the tank.
- Fill the pump set with clean water, start the machine in mixing mode. Empty the impurities from the pump chamber.



CAUTION

After washing, wait for the machine to dry and then apply grease to all lubrication points as recommended. Wipe off excess grease or oil with a dry cloth.

During work, use appropriate, close-fitting protective clothing, masks, gloves and the right tools.

- Clean suction lines, spreader and spreading equipment with pressurized water.
- Drain residual fluids through the pump valves and three-way gate valve.

Do not direct the water stream directly at the system components and equipment of the machine, i.e. the control valve, brake cylinders, pneumatic, electric and hydraulic plugs, lights, electrical connector, information and warning stickers, rating plate, conduit connectors, lubrication points, etc. High pressure of the water stream may cause mechanical damage to these elements.

- For cleaning and maintenance of plastic surfaces, use clean water or specialized preparations intended for this purpose.
- Do not use organic solvents, preparations of unknown origin or other substances that may damage the lacquered, rubber or plastic surface. Perform test on an invisible surface in case of doubt.
- Surfaces oily or greasy should be cleaned with petrol or degreasing agents, and then washed with clean water and detergent. Follow the cleaning agent manufacturer's instructions.
- Detergents intended for washing should be stored in their original containers, or alternatively, but marked exactly. Preparations cannot be stored in food and drink containers.
- Observe environmental protection principles, wash trailer in designated places.
- Washing and drying of the machine must take place at temperatures above 0 °C.

In winter, frozen water may cause damage to the pumping system and paint coating.

OBS.3.G-009.01.EN

5.10 STORAGE



DANGER

Use appropriate personal protective equipment when cleaning the machine.

Ensure adequate ventilation of the room where the machine is stored.

After finishing work, carefully clean and wash the machine. Open all drain valves of the liquid distribution system and empty the lines of the transported medium.

In the event of damage to the paint coating of metal elements, damaged areas must be cleaned of rust and dust, degreased, and then painted with paint while maintaining a uniform colour and uniform thickness of the protective coating. Until painting, damaged areas shall be covered with a thin layer of grease, anti-corrosive agent or primer.

Any repair of a damaged tank shall be commissioned to specialized workshops.

It is recommended that the machine be stored indoors or under a roof. Open all drain valves and tank covers.

When storing the machine outdoors for a long time, it is necessary to protect the machine against the influence of weather conditions, especially factors causing corrosion of steel and accelerating the aging of plastics and tires.

In the event of a longer stop, it is necessary to lubricate all points regardless of the period of the last treatment.

Wash and dry the rims and tires. During longer storage, it is recommended to move the machine once every 2-3 weeks so that the place of contact of the tire with the ground is in a different position. The tires do not deform and maintain the correct geometry. You should also check your tire pressure from time to time, and if necessary inflate the wheels to the correct value.

Store the articulated telescopic shaft for connecting to the tractor in a horizontal position.

OBS.3.G-010.01.EN

Chapter 6

Periodic inspections and the technical support

PRONAR TG214

6.1 GENERAL



CAUTION

It is forbidden to use a damaged machine.

Repairs during the warranty period may only be carried out by authorized service centres.

When using the trailer, it is necessary to constantly check the technical condition and perform maintenance procedures that will allow the machine to be kept in good technical condition. Mandatory perform all maintenance and regulatory activities specified by the manufacturer in accordance with the assumed schedule.

Repair of the during the warranty period may only be carried out by Authorized Sales and Service Points (APSiO). The machine's warranty inspection is only carried out by authorized service centres.

In the event of unauthorized repairs, changes to factory settings or activities that have not been considered as being possible by the trailer operator (not described in this manual), the user loses the warranty. Detailed information on the review schedule can be found in chapter entitled "*Maintenance and inspection schedule*".

After the warranty expires, it is recommended that inspections be carried out by specialized repair workshops.

During work, use protective clothing and protective equipment suitable for requirements.

SER.3.B-001.01.EN

6.2 HIGH-RISK PLACES



CAUTION

Depending on the type of work, use appropriate clothing and personal protective equipment.



DANGER

Before entering high-risk areas, connect the machine to the tractor. The tractor must be turned off and the ignition key removed, and the tractor cabin must be closed.

During the normal operation of the machine, it is often necessary to enter places (e.g. tank) where staying during the machine operation may cause serious injury or death of the operator. Situations that require entering and staying in such areas are:

- maintenance works,
- repair work,
- periodic and control inspections,
- removing of clogs, jamming mechanisms,
- machine cleaning,

Persons who must perform the above-mentioned activities are strictly obliged to comply with the following requirements, the fulfilment of which is absolutely necessary due to the high risk of an accident, if they are ignored.

- Before entering high-risk places, the machine should be connected to the tractor and secured against unauthorized or accidental start-up.
- Secure the machine against rolling away.
- If necessary, use certified ladders and platforms.
- Before entering high-risk areas, take the key to start the tractor connected to the machine with you and do not share it with anyone.
- Inform your co-workers about the planned work and the places where you will work.
- Never work alone. One additional person should stay outside the high risk zone.

Follow local labour laws.

SER.3.G-002.01.EN

6.3 MAINTENANCE AND INSPECTION SCHEDULE

Table 6.1 Inspection categories

| Category | Description | Performs | Frequency |
|----------|--------------|------------------------|--|
| A | Daily review | Operator | Inspection carried every day before first start-up or every 10 hours of continuous shift work. |
| B | Maintenance | Operator | Inspection performed periodically every 1000 kilometres driven or every month of machine operation, whichever comes first. Each time before carrying out this inspection, a daily inspection should be performed. |
| C | Maintenance | Operator | Inspection performed periodically every 3 months. Before each performance of this inspection, a daily inspection should be performed and a monthly inspection of the machine should be performed. |
| D | Maintenance | Operator | Inspection performed periodically every 6 months. Before each performance of this inspection, it is necessary to perform a daily inspection, inspection every 1 month of using the machine and inspection every 3 months. |
| E | Maintenance | Operator | Inspection performed periodically every 12 months. Before each performance of this inspection, it is necessary to perform a daily inspection, inspection every 1 month of using the machine and inspection every 3 months. |
| F | Warranty | APSiO ⁽¹⁾ | Inspection carried out for a fee after the first 12 months of use of the machine, after reporting the owner. |
| G | Maintenance | Service ⁽²⁾ | Inspection performed every 4 years of the machine use |

(1) - Authorized Sales and Service Point

(2) - post-warranty service

Table 6.2 Technical inspection schedule

| Description of activities | A | B | C | D | E | F | Page |
|---|--|---|---|---|---|---|------|
| Air pressure measurement, tire and rim inspection | • | | | | | | 6.16 |
| Air tank drainage | • | | | | | | 6.9 |
| Checking plugs and connection sockets | • | | | | | | 6.12 |
| Guard inspection | • | | | | | | 6.10 |
| Checking of the machine before driving | • | | | | | | 6.14 |
| Air pressure measurement, tire and rim inspection | | • | | | | | 6.16 |
| Inspection and cleaning of the delivery pumps | | • | | | | | 6.18 |
| Cleaning of the air filters | | | • | | | | 6.20 |
| Checking brake lining wear | | | | • | | | 6.22 |
| Checking of the clearance of the axle bearings | | | | • | | | 6.23 |
| Checking of mechanical brakes | | | | • | | | 6.25 |
| Cleaning of the drainage valve | | | | • | | | 6.21 |
| Adjusting of the parking brake cable tension | | | | | • | | 6.27 |
| Hydraulic system checking | | | | | • | | 6.29 |
| The pneumatic system inspection | | | | | • | | 6.31 |
| Lubrication | See table: <i>Trailer lubrication schedule</i> | | | | | | 7.47 |
| Tightening torques for screw connections | See table: <i>Schedule for tightening of the critical bolted connections</i> | | | | | | 6.32 |
| Replacement of hydraulic hoses | | | | | | • | 6.36 |

Table 6.3 Control parameters and settings

| Description | Value | Notes |
|--|------------|------------------------|
| Breaking system | | |
| Piston rod stroke in pneumatic systems | 25 - 45 mm | |
| Piston rod stroke in hydraulic systems | 25 - 45 mm | |
| Piston rod stroke in pneumatic and hydraulic systems | 25 - 45 mm | |
| Minimum brake lining thickness | 5 mm | |
| An angle between the expander axis and the fork | 90° | With the brake applied |
| Parking brake | | |
| Permissible clearance in the parking brake cable | 150 mm | |

SER.3.G-001.01.EN

6.4 PREPARING OF THE TRAILER



DANGER

Secure the tractor cab against unauthorised access.

When working with the lift, read the instructions for this equipment and follow the manufacturer's recommendations. The lift must stand firmly against the ground and machine components.

Before carrying out maintenance and repair work with the machine raised, make sure it is properly secured and will not roll away during inspection.

- Attach the machine to the tractor.
- Place the tractor and machine on firm, level ground. Set the tractor to drive straight ahead.
- Apply the tractor's parking brake.
- Turn off the tractor engine and remove the ignition key from the ignition switch. Close the tractor cab, thus securing the tractor against unauthorised access.
- Place locking chocks under the machine wheel.

Make sure the machine does not roll away during inspection.

- If the wheel needs to be lifted during inspection, place the locking chocks under the wheel of the rigid axle on the opposite side. Place the jack at the locations indicated by the arrow on the figure (6.1).

For boogie suspension, it is recommended that you support the machine in the swingarm pivot. Note the cylindrical shape of the wishbone and the difficulty in fitting the linkage correctly.

- The jack must rest on a firm and stable surface.
- The lift must be matched to the empty weight of the trailer.
- In exceptional cases, release the parking brake of the machine, e.g. when measuring the play of the running axle bearings. In this case, take special care.

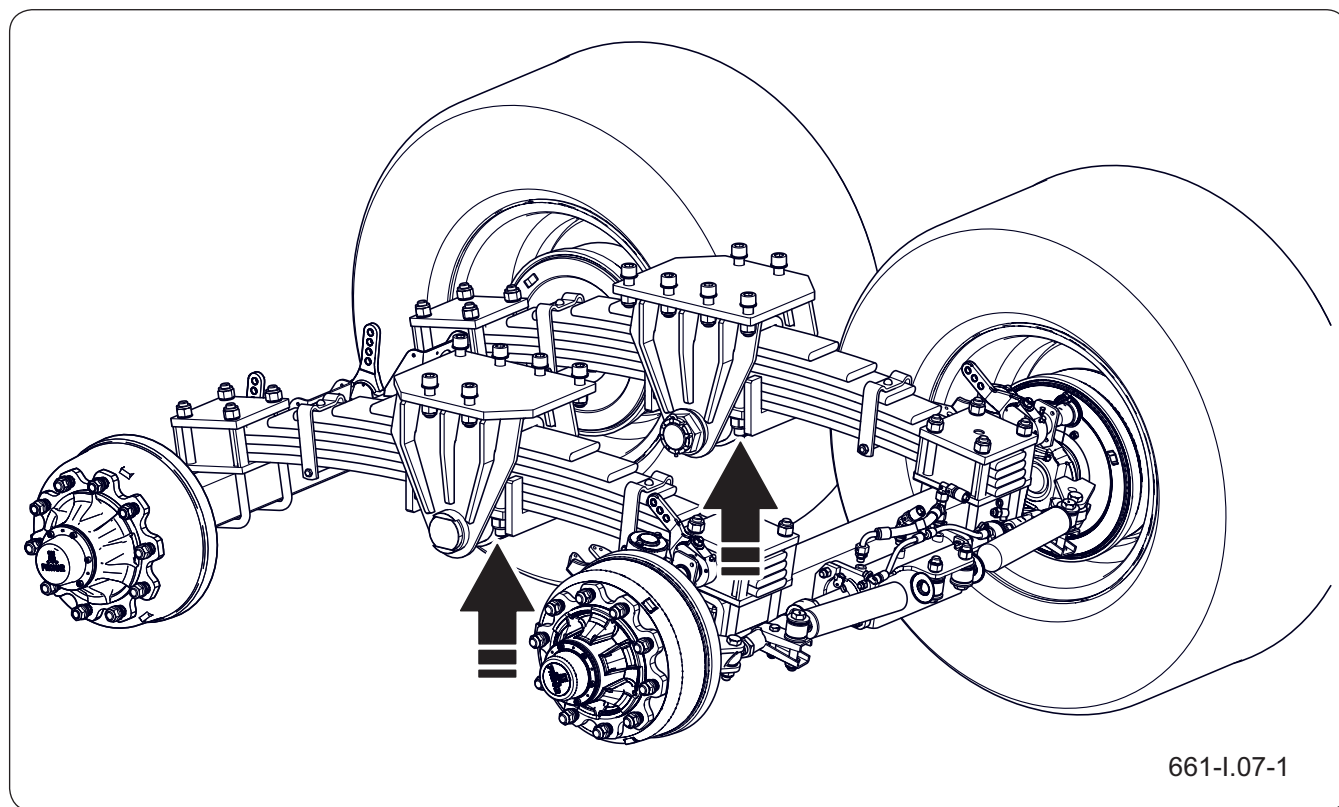

Figure 6.1 Recommended machine support points

SER.3.G-003.01.EN

6.5 AIR TANK DRAINAGE



- Press the stem of the drain valve (1) located at the bottom of the tank (2).
- The compressed air in the tank will remove water outside.
- After releasing the stem, the valve should close automatically and stop the outflow of air from the tank.
- If the valve stem does not want to return to its position, wait until the tank empties. Then unscrew and clean or replace the valve with a new one.
- If it is necessary to clean the drain valve, follow the chapter "*Cleaning the drain valve*".

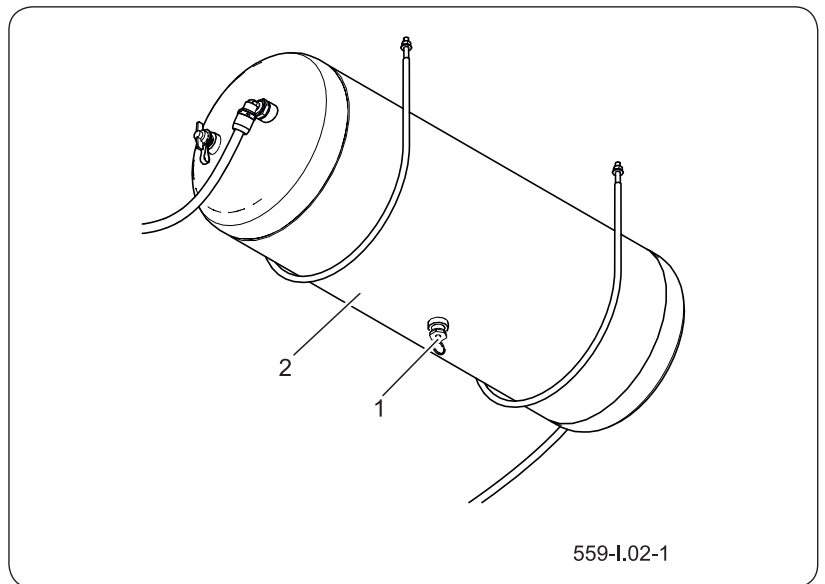

Figure 6.2 Air tank

(1) drain valve

(2) air tank

SER.3.8-004.01.EN

6.6 GUARD INSPECTION



DANGER

It is forbidden to use the machine with damaged or incomplete guards.

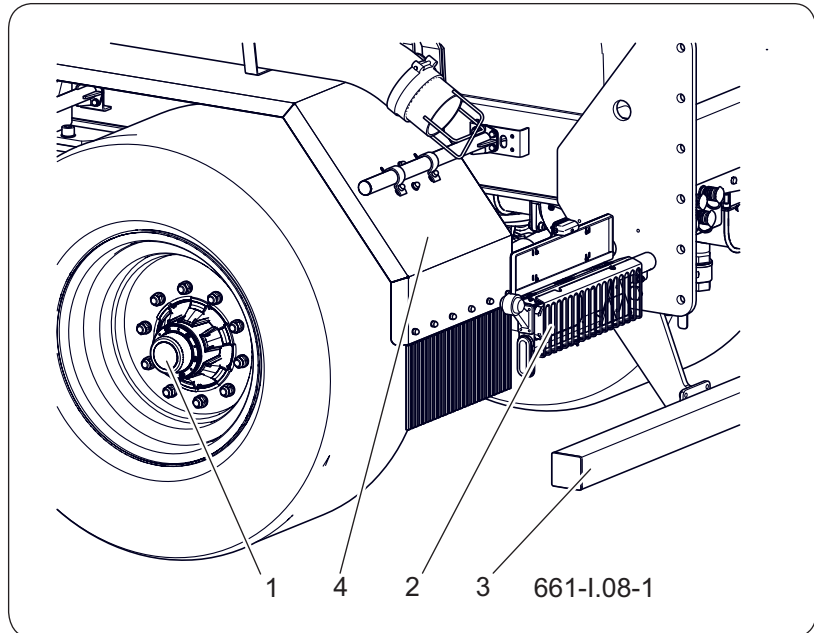

Figure 6.3 Trailer guards

(1) axle cap
(3) bumper

(2) lamp cover
(4) fender

The guards protect the user of the machine against loss of health or life and are a protective element of the machine's components. For this reason, their technical condition must be checked before starting work. Damaged or missing items must be repaired or replaced.

The scope of activities

- Check the completeness of the protective covers.
- Check if the covers are properly installed, assess the condition of the bumper (3) and the mounting of the lamp shade covers (2).
- Check that the caps (1) are secure and complete.
- Check the mudguards (4) for correct mounting.

- Tighten the screw connections of the cover fixings if necessary.

SER.3.G-004.01.EN

6.7 CHECKING PLUGS AND CONNECTION SOCKETS



A damaged body of the hydraulic or pneumatic hose connector or socket qualifies them for replacement. In the event of damage to the cover or gasket, replace these elements with new, functional ones. Contact of pneumatic connection seals with oils, grease, gasoline etc. may damage them and accelerate the aging process.

If the trailer is disconnected from the tractor,

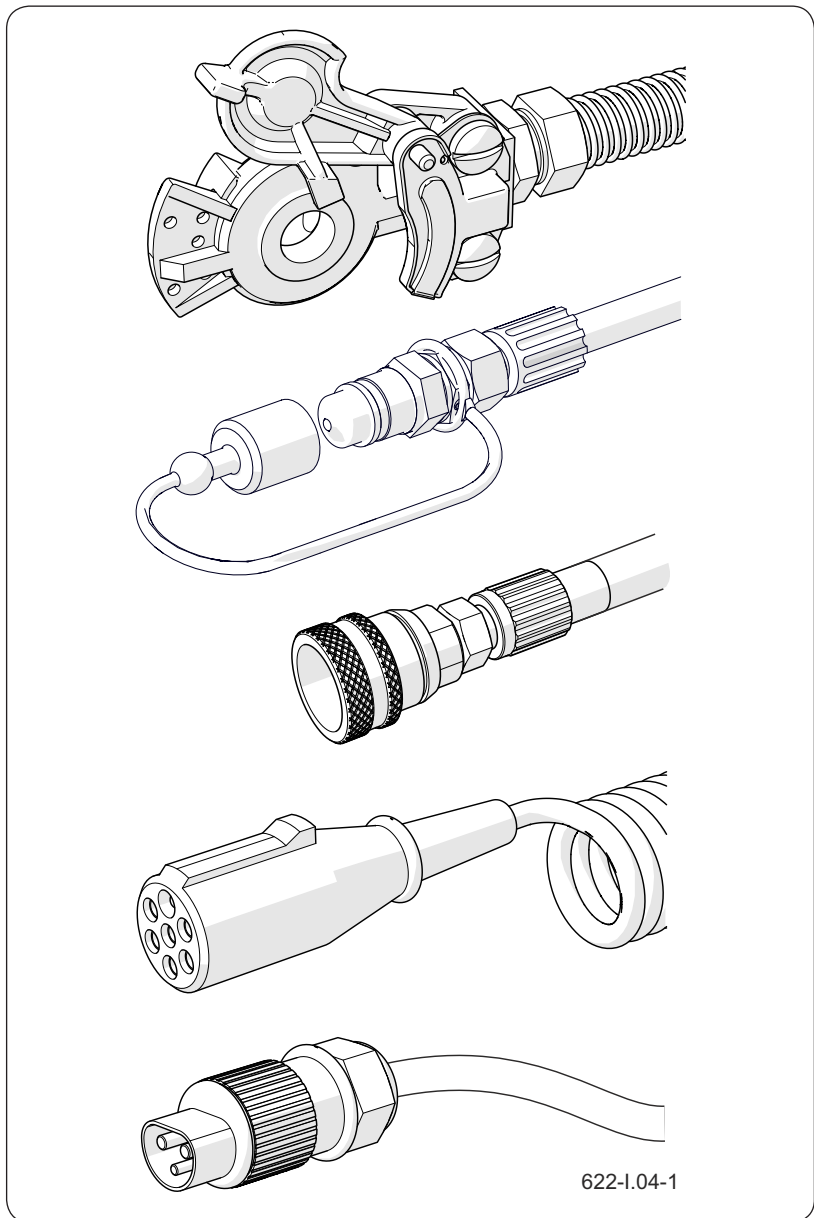

Figure 6.4 Checking the trailer connections

connections should be protected with covers or placed in their designated sockets. Before the winter period, it is recommended to preserve the seal with preparations intended for this purpose (e.g. silicone lubricants for rubber elements).

Each time before connecting the machine, check the technical condition and degree of cleanliness of connections and sockets on the agricultural tractor. If necessary clean or repair tractor sockets.

SER.3.8-005.01.EN

6.8 MACHINE CHECK BEFORE STARTING TO DRIVE



DANGER

Driving with a faulty lighting or brake system is prohibited.

If the machine is damaged, refrain from using it until it has been repaired.

- Ensure that the electrical, hydraulic and pneumatic hoses are not damaged before connecting the trailer to the tractor.
- Check the completeness, technical condition and correct operation of the machine lighting.
- Check the cleanliness of all electric lamps and reflectors.
- Before driving on a public road, remove the tail lamp covers and place them in the space provided.
- Mount the triangular plate of a slow-moving vehicle
- Ensure that a warning reflective triangle is fitted to the tractor.
- Check that the actuator vents are not clogged with debris and that there is no water or ice inside. Check that the actuator is fitted correctly.
- Clean the actuator if necessary. During the winter period, it may be necessary to defrost the actuator and remove accumulated water

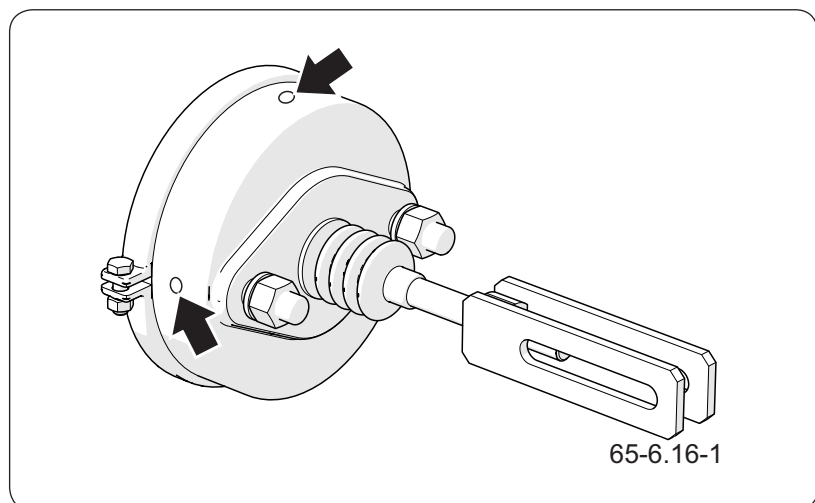

Figure 6.5 Brake actuator

through the blocked vents. If damage is found, replace the actuator.

- When starting from a standstill, check the function of the service brake system. An adequate level of air pressure in the machine's air tank is required for proper operation of the pneumatic system.
- Check the correct functioning of the other systems on an ongoing basis during the operation of the machine.

SER.3.G-006.02.EN

6.9 AIR PRESSURE MEASUREMENT, TIRE AND RIM INSPECTION



ADVICE

In the event of intensive use of the machine, we recommend more frequent pressure checks.



CAUTION

Using a machine in which tires are not properly inflated may lead to permanent tire damage as a result of delamination of the material.

Incorrect tire pressure also causes faster wear of the tire.

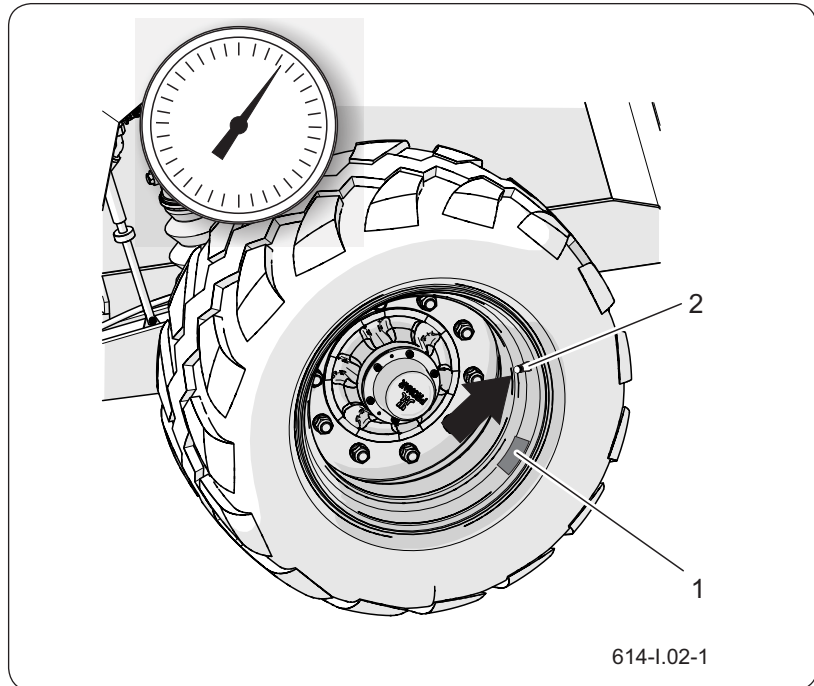

Figure 6.6 Trailer's wheel

(1) sticker

(2) valve

The machine must be unloaded during pressure measurement. The inspection should be performed before driving, when the tires are not warm, or after the machine has been parked for a longer period of time.

The scope of activities

1. Connect the pressure gauge to the valve.
2. Check the air pressure.
3. If necessary, inflate the wheel to the required pressure.

The required air pressure is described on a sticker (1) on the rim.

4. Check the tread depth.
5. Check the side wall of the tire.
6. Inspect the tire for defects, cuts, deformations,

bumps indicating mechanical damage to the tire.

7. Check that the tire is correctly positioned on the rim.
8. Check the tire age.

When checking pressure, pay attention to the technical condition of rims and tires. In the event of mechanical damage, consult your nearest tire service centre and ensure that your tire defect is eligible for replacement. Rims should be checked for deformation, material cracks, weld cracks, corrosion, especially around welds and in the place contact with the tire.

SER.3.G-007.01.EN

6.10 INSPECTION AND CLEANING OF THE DELIVERY PUMP



ADVICE

At the factory, the gearbox is filled with SAE 90 EP gear oil (API GL-5 SAE 80W/90).

CAUTION

Check the oil level in the gearbox before each working season or once every six months.

Perform the oil level check with the machine turned off, the oil should be cooled down.

Do not overfill the gearbox with oil. Too much oil can cause the gearbox to overheat.

If you notice an oil leak, carefully inspect the seals, check the oil level.

Operation of the gearbox with a low or no oil level can lead to permanent damage to its mechanism.

DANGER

During work related to the control and refilling of oil, use appropriate personal protective equipment, i.e. protective clothing, shoes, gloves, glasses. Avoid oil contact with skin.

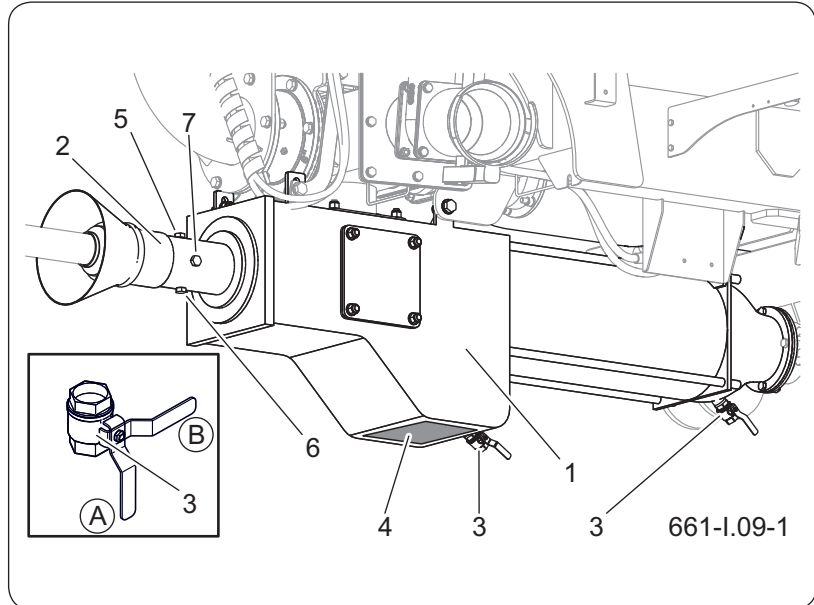

Figure 6.7 Checking the gearbox oil level

- | | |
|---------------------|---------------------|
| (1) pump chamber | (2) gear |
| (3) drain valve | (4) flap |
| (5) filler plug | (6) drain plug |
| (7) inspection plug | |
| (A) open position | (B) closed position |

Checking of the gearbox oil level

- Level the machine up and block it with the parking brake and,
- Disconnect the drive shaft,
- Check the lateral and axial play of the gear bearings by gripping the gear shaft,
- Unscrew the plug (7) and check the gearbox oil level (2).
- If necessary, unscrew the oil filler plug (5) and add oil to the required level. Tighten the plug.

The oil level should coincide with the lower edge of the inspection hole of the plug (7).

- Tighten the plug (7).

ADVICE

Replace the transmission bearings after 20,000 hours of operation or after 5 years of machine operation.



CAUTION

After 50 hours of pump operation, check and, if necessary, tighten all screw connections of the pump.

Changing of the transmission oil

- Level the machine up and block it with the parking brake and,
- Disconnect the drive shaft,
- Unscrew the filler plug (5), then the drain plug (6), empty the gearbox of the used oil.
- Screw on the cap (6)
- Pour oil into the gearbox.

The oil level should coincide with the lower edge of the inspection hole of the plug (7).

- Tighten the plug (7).

SER.3.G-008.01.EN

6.11 CLEANING THE AIR FILTERS



The scope of activities

- Reduce pressure in the supply line.
- The pressure in the pipe can be reduced by pushing the plug of the pneumatic connection as far as it will go.
- Slide out the filter lock (1).
- Hold the filter cover (2) with your other hand. After removing the slide, the cover will be pushed out by the spring located in the filter housing.
- The cartridge and the filter body should be thoroughly washed and blown out with compressed air. Installation should be made in reverse order.

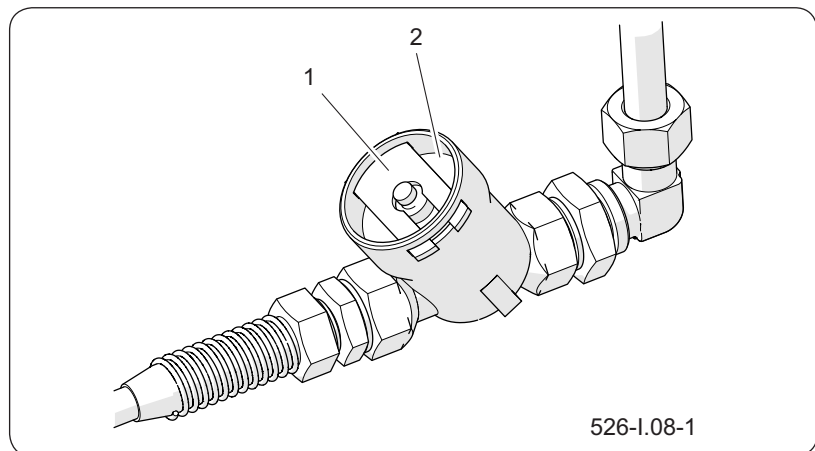

Figure 6.8 Air filter
(1) filter (2) cover

SER.3.8-008.01.EN

6.12 CLEANING THE DRAINAGE VALVE



DANGER

Bleed the air tank before removing the drain valve.

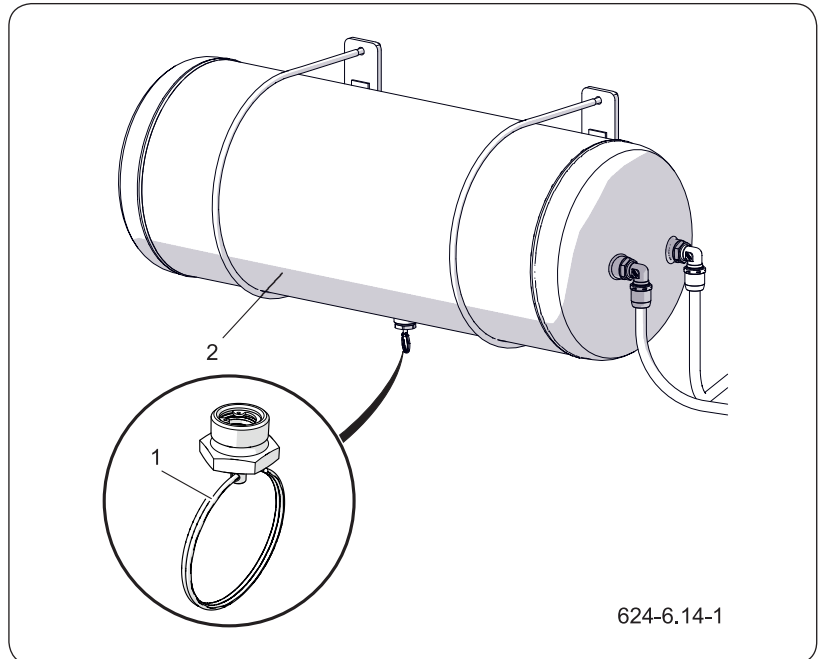

Figure 6.9 Air tank

(1) drain valve

(2) tank

The scope of activities

- Fully reduce the pressure in the air reservoir (2).
- The pressure in the tank can be reduced by swinging the drain valve stem.
- Unscrew the valve (1).
- Clean the valve, blow with compressed air.
- Replace the gasket.
- Screw in the valve, fill the tank with air, check the tank for leaks.

SER.3.8-012.01.EN

6.13 CHECKING BRAKE LINING WEAR



ADVICE

Brake lining wear control,

- according to the schedule of inspections,
- if the brakes overheat,
- the stroke of the brake cylinder piston significantly increases,
- in the event of unnatural noises coming from around the road axle drum.

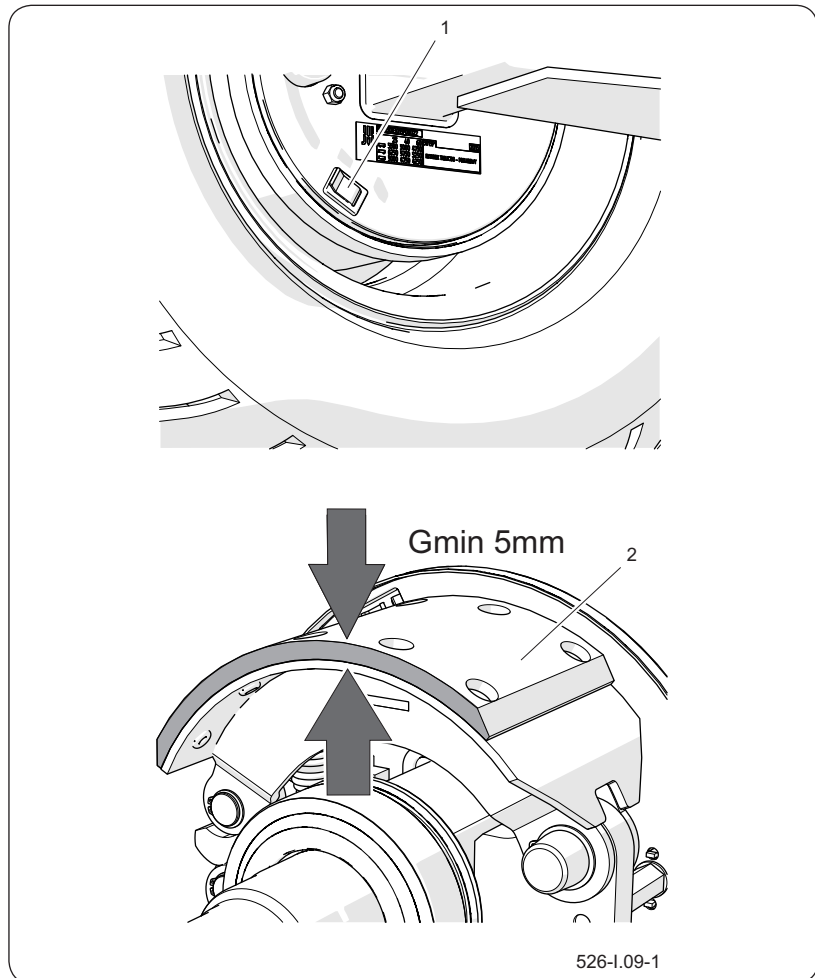

Figure 6.10 Checking the brake lining thickness
(1) blanking plug (2) brake lining

- Find the inspection hole.
Depending on the version of the road axle, the inspection hole may be located in a different place than the figure shows, but it will always be located on the brake shield.
- Remove the upper and lower plugs and then check the thickness of the lining.
- The brake shoes must be replaced if the thickness of the brake lining is less than 5 mm.
- Check the the remaining linings for wear.

SER.3.8-009.01.EN

6.14 CHECKING OF THE CLEARANCE OF THE AXLE BEARINGS



ADVICE

A damaged hub cover or lack of it will cause the penetration of dirt and moisture to the hub, which will result in much faster wear of the bearings and hub seals.

Bearing life depends on machine operating conditions, load, vehicle speed and lubrication conditions.



DANGER

Before starting work, read the jack User's Manual.

Ensure that the machine will not roll when checking the looseness of the axle bearings.

Control the play of bearings only when the machine is connected to the tractor and is unloaded.



Figure 6.11 Clearance checking

- Raise the wheel with a jack.
- Turn the wheel slowly in two directions. Check that the movement is smooth and the wheel rotates without excessive resistance and jamming.
- Turn the wheel so that it rotates very quickly, check that the bearing does not make any unusual sounds.
- Try to feel looseness by moving the wheel.
- Repeat steps separately for each wheel.

Remember that the lift must be on the opposite side of the wedges!

- If looseness is felt, adjust the bearings. Unnatural sounds coming from the bearing may be symptoms of excessive wear, dirt or damage. In this case, the bearing together with the sealing rings should be replaced or cleaned and re greased. When checking bearings, make sure that any noticeable looseness comes from the bearings, not the suspension system

(e.g. looseness on the spring pins, etc.).

- Check the the technical condition of the hub cover, replace if necessary.

SER.3.G-009.01.EN

6.15 CHECKING OF MECHANICAL BRAKES



ADVICE

Checking the technical condition of the brakes:

- according to the schedule of inspections,
- before the period of intensive use.
- after repairing the braking system.
- in the event of uneven braking of the trailer wheels.

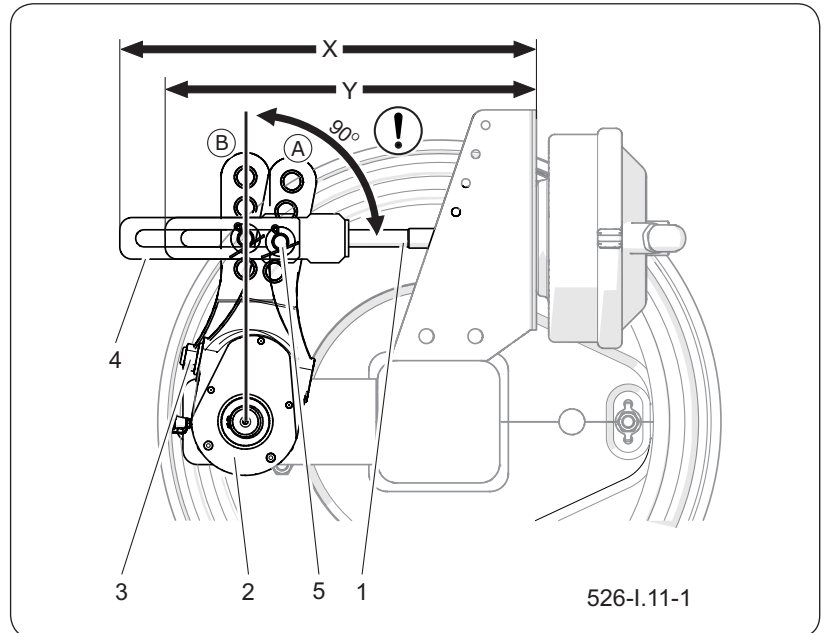

Figure 6.12 Brake check

- (1) cylinder piston (2) expander arm
 (3) adjustment screw (4) of the cylinder fork
 (5) pin position
 (A) position of the arm in the released position
 (B) arm position in braking position

In a correctly adjusted brake the cylinder piston stroke brake should be within the range given in Table 6.3 and depends on the type of cylinder used. When the wheel is fully braked, the optimal angle between the expander lever and the piston rod should be approx. 90 °. With this setting, the braking force is optimal. Checking the brakes consists in measuring this angle and the piston rod stroke in each wheel.

The scope of activities

- Measure the distance X with the tractor brake pedal released.
- Measure the distance Y with the tractor brake

pedal pressed.

- Calculate the distance difference X-Y (rod stroke).
- Check the angle between the cylinder piston axis and the expander lever.
- If the expander arm angle (2) and piston rod stroke exceed the range given in table 5.3, the brake should be adjusted.

SER.3.8-011.11.EN

6.16 ADJUSTING OF THE PARKING BRAKE CABLE TENSION

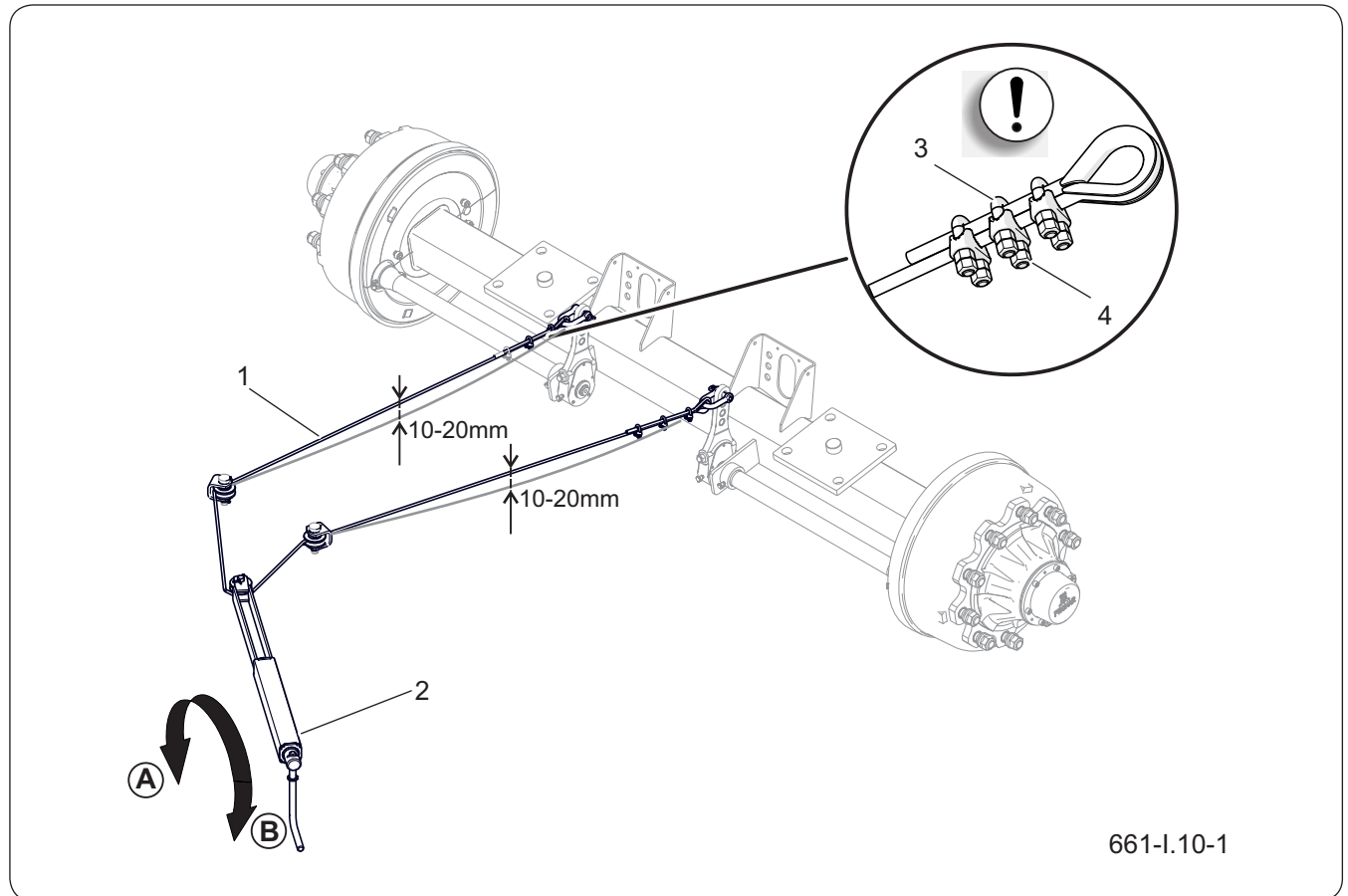

Figure 7.13 Cable tension adjustment

(1) cable,

(2) brake mechanism,

(3) bow clamp,

(4) clamp nut



DANGER

It is forbidden to use the machine with inefficient braking system.

Tension control

Check the parking brake after checking the mechanical brake of the axle.

- Connect the machine to the tractor. Place the machine and tractor on level ground.
- Under one wheel of the machine's rigid axis put the wedges;
- Turn the parking brake crank (2) towards (B) and apply the parking brake.
- Check the cable tension (1).
- When the mechanism screw is completely removed, the cable should hang about 10 to 20

mm.

Cable tension adjustment

- Unscrew the bolt of the brake mechanism (2) as far as possible by turning the crank in direction (A).
- Loosen the the nuts (4) of the bow clamps (3) on the handbrake cable (1).
- Tighten the cable (1) and tighten the the nuts (4) of the clamps.
- Apply the parking brake and release it again. Check (approximately) cable slack. With the service and parking brakes fully released, the cable should hang about 10-20 mm. The axle spreader levers should be in the rest position.

SER.3.G-010.01.EN

6.17 HYDRAULIC SYSTEM CHECKING



UWAGA

It is forbidden to use the machine with a faulty hydraulic installation.

Checking the tightness of the hydraulic system

- Connect the trailer to tractor.
- Connect all hydraulic system hoses according to the instructions in the manual.
- Clean the hose connections, hydraulic cylinders and couplings.
- Activate all hydraulic systems in turn, extending and retracting the piston rods of the cylinders. Repeat all operations 3-4 times.
- Leave the hydraulic cylinders fully extended. Check the all hydraulic circuits for leaks.
- After completing the inspection, put all cylinders to the rest position.

In the event of oiling on the hydraulic cylinder body, the nature of the leakage must be check.

When the cylinder is fully extended, check the the seal locations. Small leaks with symptoms of "sweating" are permissible. When you notice "droplets" type leaks do not use the machine until the fault is removed. If malfunctions appeared in brake cylinders or other brake installation elements, you can not move with the trailer until the fault is removed.

If visible moisture appears on the cable connectors tighten the connector with a specified torque and carry out the test again. If the problem persists replace the leaking element.

Control of the technical condition of hydraulic connectors

Hydraulic couplings for connecting to the tractor must be technically sound and kept clean. Each time before connecting, make sure that the sockets in the tractor are maintained in good condition. The tractor's and trailer's hydraulic systems are sensitive to the

presence of solid impurities that can cause damage to precise components of the installation (scratch the surface of cylinders, etc.)

SER.3.8-015.01.EN

6.18 THE PNEUMATIC BRAKING SYSTEM INSPECTION



DANGER

It is forbidden to use the machine with inefficient braking system.



DANGER

Repair, replacement or regeneration of pneumatic system components may be performed only in a specialized workshop.

The scope of activities

- Connect the machine to the tractor.
- Block the tractor and the machine with the parking brake. Put the wedges under one wheel of the rigid axis of the machine.
- Start the tractor to supplement the air in the machine braking system tank.
- Switch off the tractor engine.
- Check the the system components with the tractor brake pedal released.
- Pay special attention to cable connections and brake actuators.
- Repeat the system check with the tractor brake pedal depressed.

In the event of a leak, the compressed air will leak out in places of damage with a characteristic hiss. The leakage of the system can detect coating checked elements for washing or other foaming preparation, which will not interact aggressively to the elements of the installation. Damaged elements should be replaced or sent for repair. If the leak appeared around the connections, user can tighten the connector on their own. If the air continues to leak replace the elements of the connector or sealing into new ones.

When checking for leaks, pay attention to the technical condition and degree of cleanliness of the system components. Contact of pneumatic conduits, seals etc. with oil, grease, gasoline etc. may damage them or accelerate the aging process. Bisted, permanently deformed, cut or damaged wires should be replaced for new ones.

SER.3.G-019.01.EN

6.19 TIGHTENING TORQUES FOR SCREW CONNECTIONS



During maintenance and repair work, apply appropriate tightening torques to screw connections, unless other tightening parameters are given. Recommended tightening torques for the most commonly used bolted connections are shown in the Table “*Tightening torques for screw connections*”. The given values apply to non-lubricated steel bolts.

Hydraulic lines and other hydraulic components with rubber seals should be tightened with torque according to the Table “*Tightening torques of hydraulic elements*”.

Check the tightness using a torque wrench. During daily inspection of the machine pay attention to loose connections and tighten the connector if necessary. Replace the lost elements with new ones.

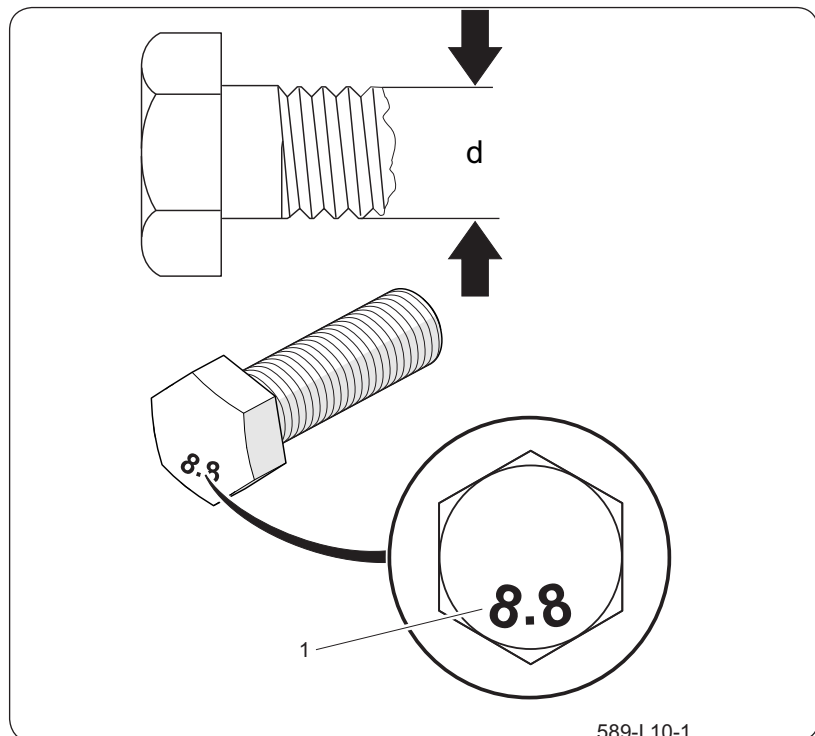

Figure 6.14 Screw with metric thread
(1) strength class, (d) thread diameter

Table 6.4 Tightening torques for screw connections

| Metric | | |
|--------|--------------------|---------------------|
| | 8.8 ^(*) | 10.9 ^(*) |
| M8 | 25 | 36 |
| M10 | 49 | 72 |
| M12 | 85 | 125 |
| M14 | 135 | 200 |
| M16 | 210 | 310 |
| M20 | 425 | 610 |
| M24 | 730 | 1,050 |
| M27 | 1,150 | 1,650 |
| M30 | 1,450 | 2,100 |

(*) - strength class according to DIN ISO 898

Table 6.5 Tightening torques of hydraulic elements

| Thread of nuts | Wire diameter DN (inch) | Tightening torques [Nm] |
|-----------------------------|----------------------------|----------------------------|
| M10x1 M12x1.5 M14x1.5 | 6 (1/4") | 30÷ 50 |
| M16x1.5 M18x1.5 | 8 (5/16") | 30÷ 50 |
| M18x1.5 M20x1.5 M22x1.5 | 10 (3/8") | 50÷ 70 |
| M22x1 M24x1.5 M26x1.5 | 13 (1/2") | 50÷ 70 |
| M26x1.5 M27x1.5 M27x2 | 16 (5/8") | 70÷ 100 |
| M30x1.5 M30x2 M33x1.5 | 20 (3/4") | 70÷ 100 |
| M38x1.5 M36x2 | 25 (1") | 100÷ 150 |
| M45x1.5 | 32 (1.1/4") | 150÷ 200 |

SER.3.G-011.01.EN

6.20 TIGHTENING ROAD WHEELS

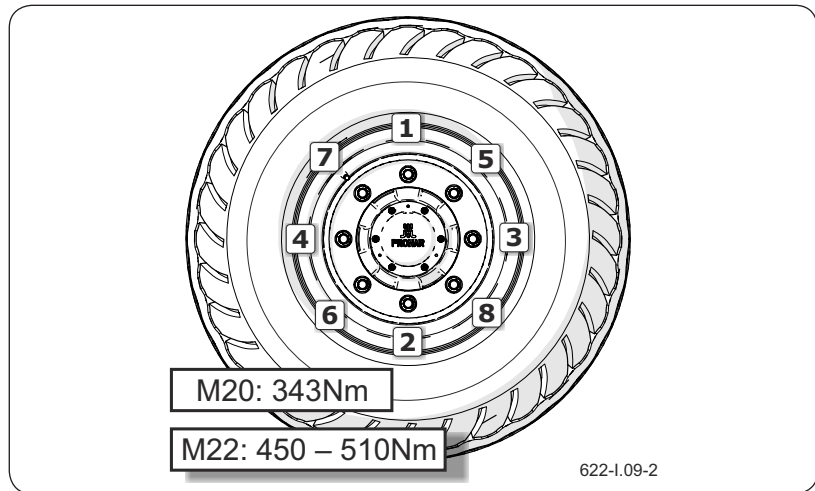

Figure 6.16 The order of the nuts tightening (8 pcs)

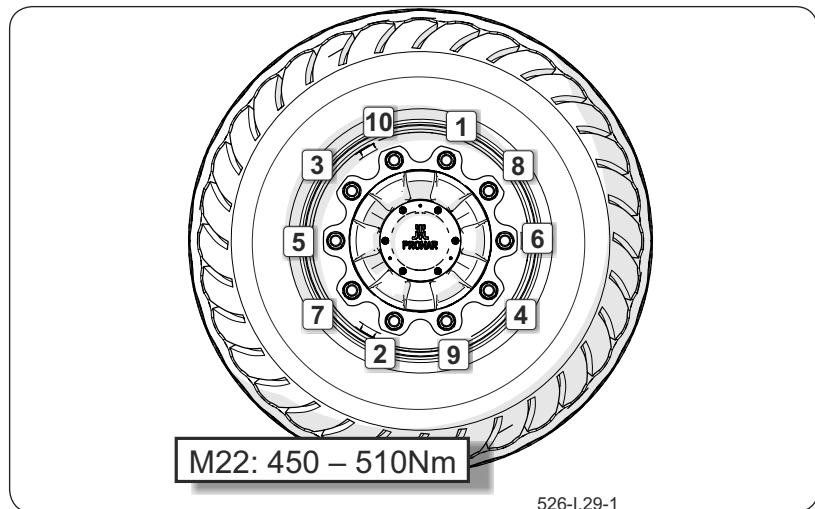

Figure 6.15 The order of the nuts tightening (10 pcs)

The wheel nuts be tightened gradually diagonally (in several stages until the required tightening torque is achieved), using a torque wrench. The recommended order of tightening of the nuts and the tightening torque is shown on the figures.

Wheel nuts must not be tightened with impact wrenches, due to the danger of exceeding the permissible tightening torque, which may result in breaking

the connection thread or breaking the hub pin.

The wheels should be tightened according to the following scheme:

- after first use of the machine (one-time inspection),
- every 2-3 hours of driving during the first month of use,
- every 30 hours of driving.

If the wheel was disassembled, the above steps should be repeated.

SER.3.8-018.01.EN

6.21 REPLACEMENT OF HYDRAULIC HOSES



Rubber hydraulic hoses should be replaced every 4 years regardless of their technical condition. This operation should be entrusted to specialized workshops.

SER.3.8-020.01.EN

6.22 BOOGIE SUSPENSION CONTROL

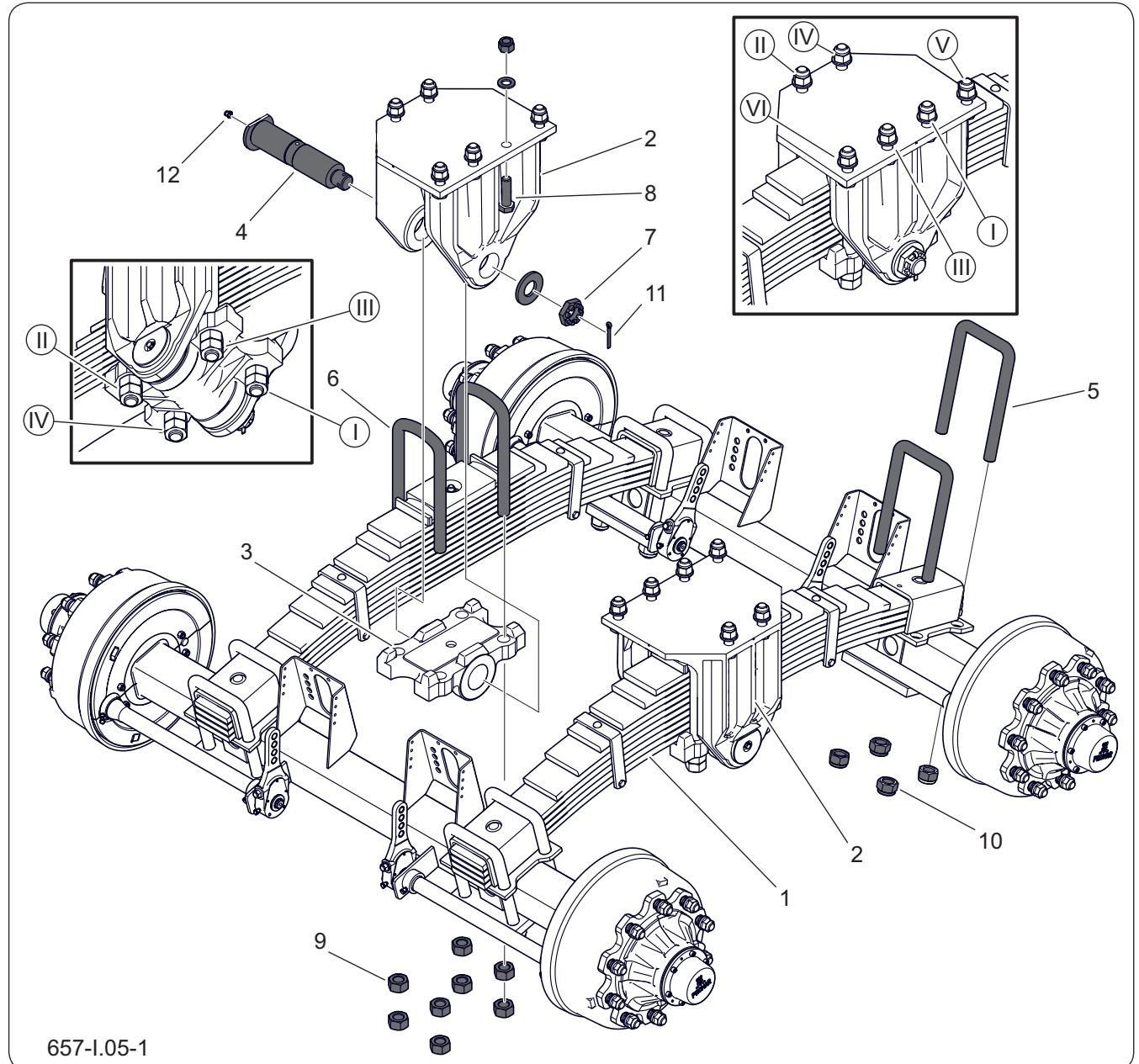

Figure 6.17 Mechanical suspension operation

(1) spring, (2) bracket, (3) control arm, (4) control arm pin, (5) axle U-bolt, (6) control arm U-bolt, (7) pin cap nut, (8) bracket bolt, (9) control arm U-bolt nut, (10) axle U-bolt nut, (11) cotter pin, (12) grease nipple

ADVICE

In case of heavy use or intensive operation, maintenance should be performed more frequently.

Table 6.6 Suspension check schedule

| No. | Maintenance operations | Frequency |
|-----|---|--|
| 1 | <p>Check the tightness of the nuts (9) of the shackle bolts (6) with a torque of 725 - 750 Nm using a torque spanner. Course of control:</p> <ul style="list-style-type: none"> - unscrew the lock nuts, - tighten the nuts first with a torque of 500Nm diagonally, then with a torque of 725 - 750Nm. | <p>After driving the first 50 km with a load, or after 500 hours of operation. After 5,000 km or after 1,500 hours of operation, then once a year.</p> |
| 2 | <p>Check the tightness of the nuts (10) of the shackle bolts (5) with a torque of 550 - 600 Nm using a torque spanner. Course of control:</p> <ul style="list-style-type: none"> - tighten the nuts first with a torque of 250Nm diagonally, then with a torque of 400Nm, and in the last step tighten the nuts with a torque of 550 - 600Nm. | <p>After driving the first 50 km with a load, or after 500 hours of operation. After 5,000 km or after 1,500 hours of operation, then once a year.</p> |
| 3 | <p>Inspection of the pivot pin (4) and control arm (2) sliding bushings.</p> <p>The inspection consists of a visual assessment of the wear on the sliding sleeves. Wear is an indication of inadequate lubrication of the pins. In this case, dismantle the control arm pin (4) and the control arm (3), assess the wear on the pin and the sliding bushings, replace them with new ones if necessary and recondition the pin socket.</p> | <p>Every 5,000 km or quarterly.</p> |
| 3 | <p>Checking the security of the crown nuts (7) of the control arm pins (4). The inspection consists of a visual check of the completeness and condition of the safety pins (11).</p> | <p>Once a year</p> |

| No. | Maintenance operations | Frequency |
|-----|---|--------------------|
| 4 | Check the condition of the springs (1) clean thoroughly and brush the sides of the springs to check for cracks. | <i>Once a year</i> |

SER.3.G-012.01.EN

**CAUTION**

Tighten suspension screw connections under load.

The use of pneumatic spanners is not permitted during tightening. Tighten bolted connections using a torque spanner.

6.23 ADJUSTMENT OF THE CLEARANCE OF WHEEL AXLE BEARINGS



CAUTION

Adjust the play of bearings only when the machine is connected to the tractor and unloaded.

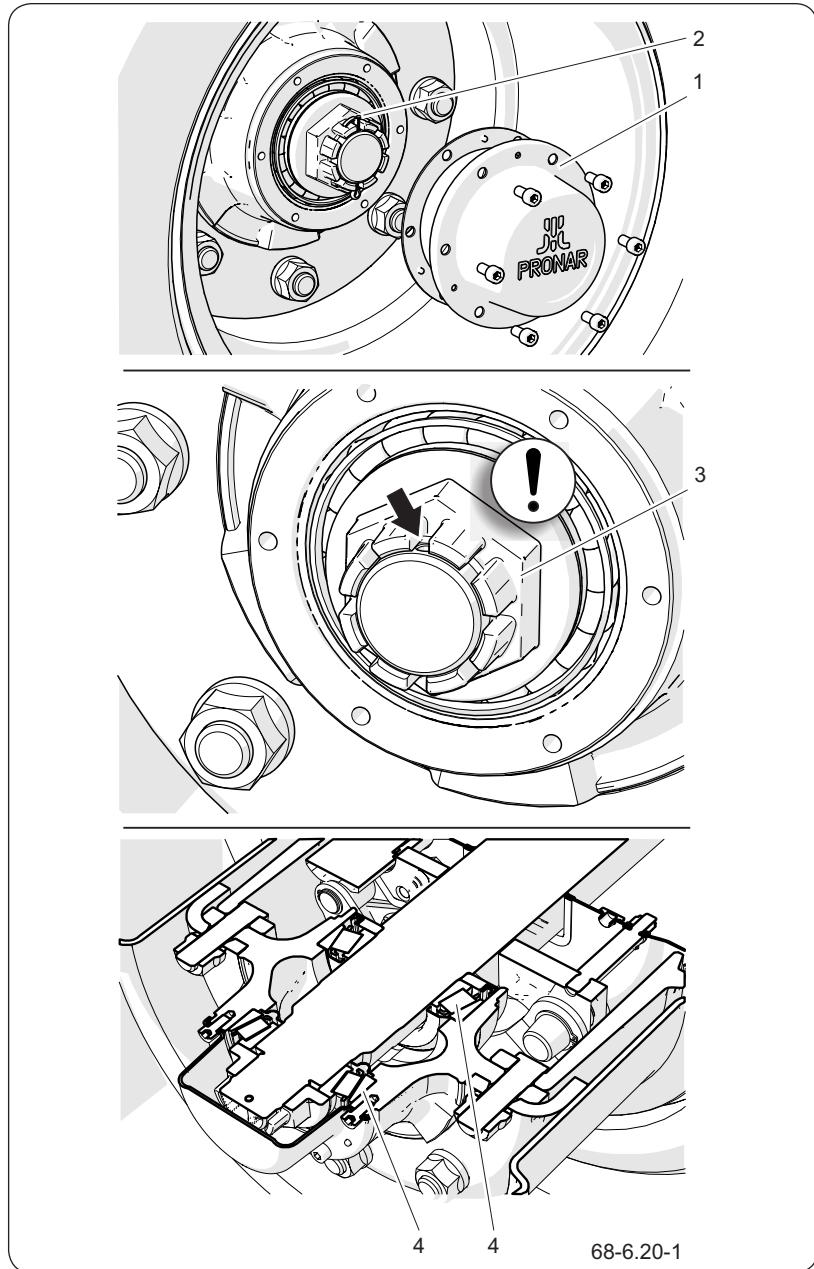

Figure 6.18 The principle of bearing clearance adjustment

- | | |
|----------------|----------------------------|
| (1) hub cover, | (2) cotter pin, |
| (3) nut, | (4) tapered roller bearing |

The scope of activities

Prepare the tractor and machine for adjustment as described in chapter „Preparing of the machine”.

- Remove the hub cover (1).

- Remove the cotter pin (2) securing the castellated nut (3).
- Tighten the the castellated nut to remove slack.
The wheel should rotate with slight resistance.
- Unscrew the nut (3) (not less than 1/3 of a turn) to cover the nearest groove of the nut with a hole in the journal of the axle (the pin's hole is marked with a black arrow in the drawing). The wheel should rotate without excessive resistance.
The wheel should rotate without excessive resistance. Too strong pressure is not recommended due to the deterioration of bearings.
- Secure the castellated nut with a cotter pin and mount the hub cover (1).
- Gently tap the hub with a rubber or wooden hammer.

SER.3.G-013.01.EN

6.24 BRAKE ADJUSTMENT

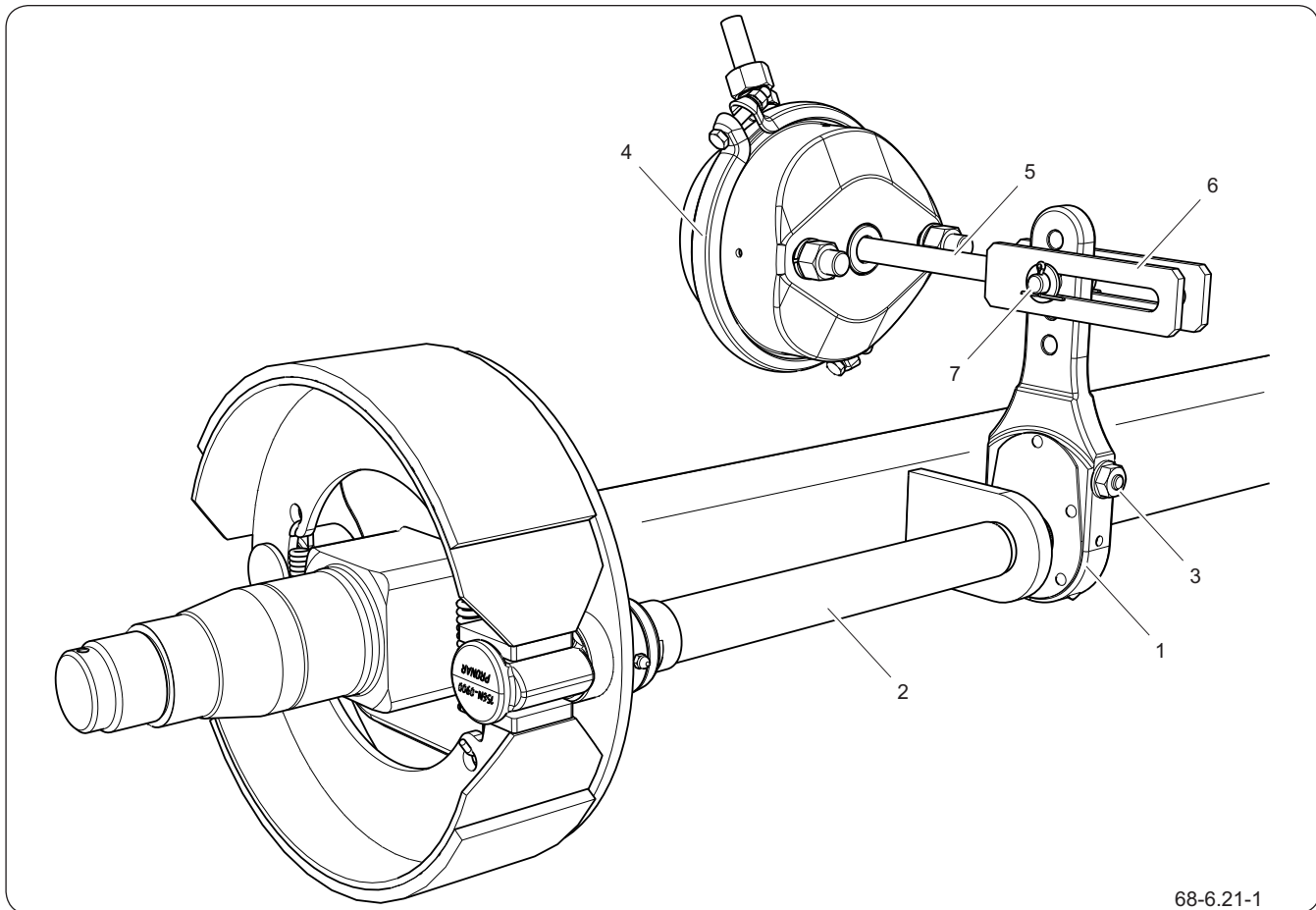

Figure 6.19 Construction of the pneumatic brake of the driving axle

- | | | |
|-------------------------|---------------------|----------------------|
| (1) expander arm, | (2) expander shaft, | (3) adjusting screw, |
| (4) pneumatic cylinder, | (5) cylinder, | (6) cylinder fork, |
| (7) cylinder pin | | |

ADVICE

The correct stroke of the piston rod should be in the range of 25 -45 mm.

Significant wear of brake shoe linings causes an increase in the stroke of the brake cylinder piston rod and deterioration of braking efficiency.

During braking, the piston rod stroke should be within the specified operating range, and the angle between the piston rod (1) and the expander arm (3) should be approximately 90°. The machine wheels must brake simultaneously.

The braking force also decreases when the angle of operation of the brake actuator piston rod (5) is

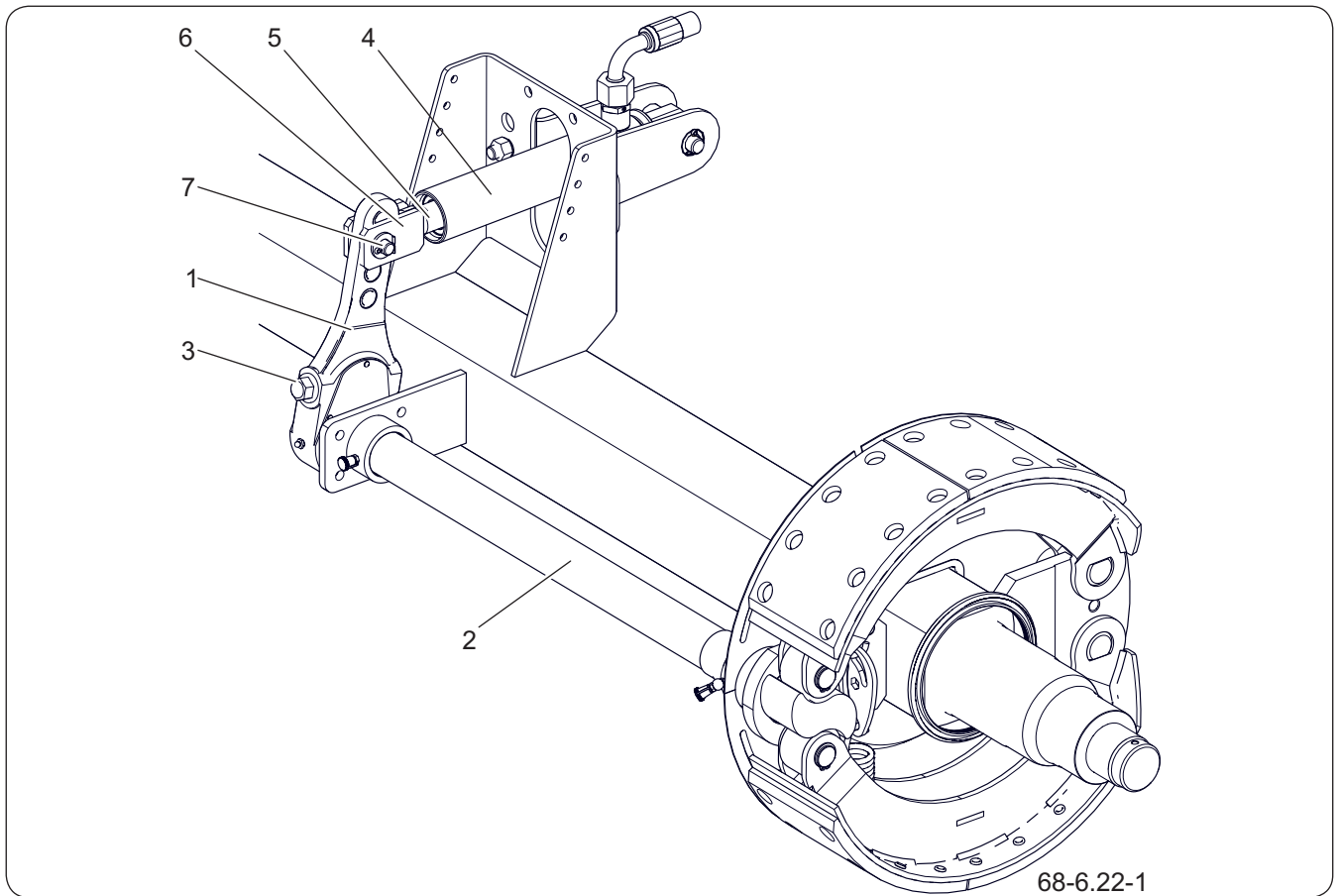

Figure 6.20 Construction of the hydraulic brake of the driving axle

Construction of the hydraulic brake of the driving axle

(1) expander arm,

(2) expander shaft,

(3) adjusting screw,

(4) hydraulic cylinder,

(5) cylinder piston rod,

(6) cylinder fork,

(7) cylinder pin



CAUTION

Incorrectly adjusted brake may cause the brake shoes to rub against the drum, which may result in faster wear of the brake linings and/or overheating of the brake.

not appropriate in relation to the expander arm (1). In order to obtain the optimal mechanical operating angle, the piston rod fork (6) must be mounted on the expander arm (1) in such a way that the operating angle amounts to approx. 90° when fully braking.

The control consists in measuring the extension length of each piston rod while braking at a standstill. In the event that the piston rod stroke exceeds the maximum value (45mm), the system should be adjusted.

When disassembling of the cylinder fork (6), remember or mark the original position of the cylinder fork pin (7). The mounting position depends on the type of braking system and the size of the tires used

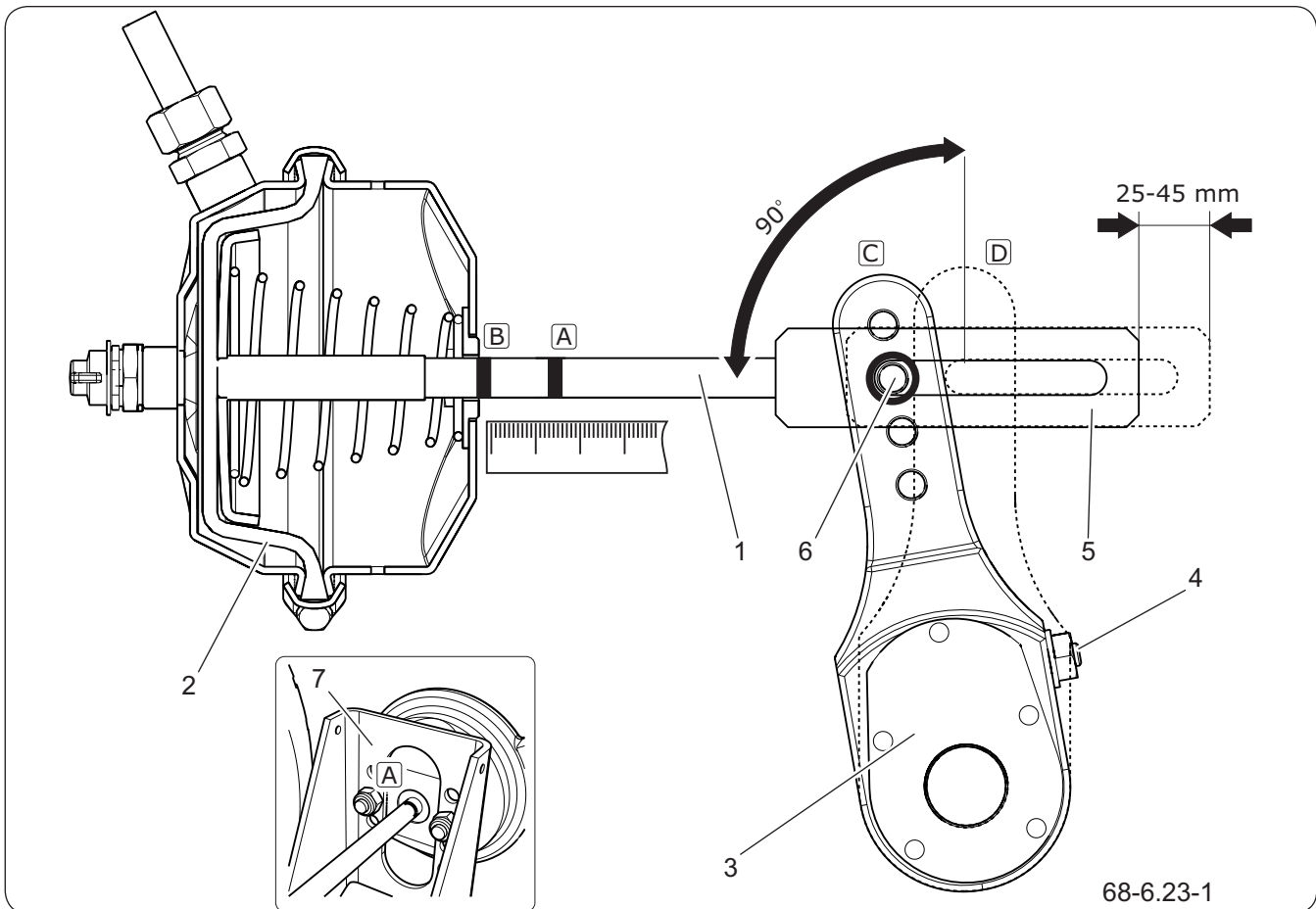

Figure 6.21 Pneumatic brake adjustment principle

- (1) piston, (2) cylinder membrane, (3) expander arm,
 (4) adjustment screw, (5) cylinder fork, (6) fork pin,
 (7) cylinder support

(A) the tag on the piston in the brake release position, (B) the tag on the pistons in the full stop position, (C) the position of the arm in the brake release position, (D) arm in full stop position



CAUTION

The mounting positions of the brake actuator in the bracket holes and the actuator pin in the expander arm are determined by the Manufacturer and cannot be changed.

Each time when removing the pin or the actuator, it is recommended to mark the place of the original fastening.

in the machine, it is selected by the Manufacturer and cannot be changed.

The scope of activities

- Connect the machine to the tractor.
- Turn off the tractor engine and remove the ignition key.
- Immobilize tractor with parking brake.
- Make sure the machine is not braked.
- Secure the machine against rolling with wheel chocks.
- On the piston rod (1) of the cylinder mark with a line (A) the position of the maximum retraction

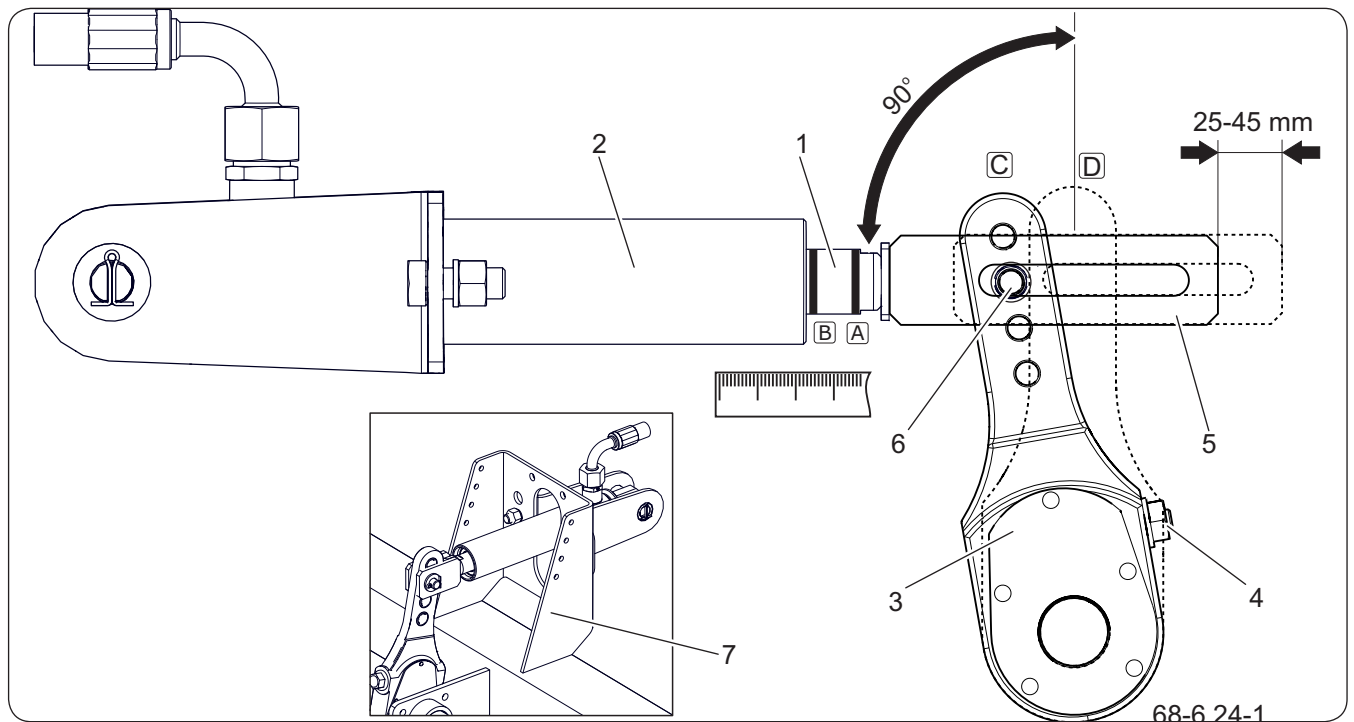

Figure 6.22 Hydraulic brake adjustment principle

- (1) piston rod, (2) cylinder piston, (3) expander arm,
 (4) adjustment screw, (5) cylinder fork, (6) fork pin,
 (7) cylinder bracket (A) mark on the piston rod in the release position,
 (B) the mark on the piston rod in the fully braked position,
 (C) position of the arm in the unbraked position, (D) arm in full stop position

of the piston rod with the trailer brake off.

- Press the brake pedal on the tractor, mark with a line (B) the position of maximum extension of the piston rod.
- Measure the distance between the lines (A) and (B). If the piston rod stroke is not within the correct working range (25-45mm), adjust the expander arm.
- Remove the the actuator fork pin (6).
- Remember or mark the original position of the cylinder fork (6) in the expander arm bore (3).
- Check the that the cylinder piston moves freely and within the full nominal range.
- Check that the air vents of the actuator are not clogged with dirt and that there is no water or ice inside (pneumatic actuator). Check the

correct mounting of the actuator.

- Clean the cylinder, defrost if necessary and drain water through the unblocked ventilation holes (pneumatic cylinder). If damage is found, replace the actuator with a new one. When mounting the actuator, keep its original position relative to the bracket (7).
- Turn the adjusting screw (4) so that the marked hole of the expander arm coincides with the hole of the cylinder fork
- During adjustment, the diaphragm (2) must rest on the rear wall of the cylinder (pneumatic cylinder).
- Install the piston rod fork pin and washers and secure the pin with cotter pins.
- Turn the adjusting screw (4) clockwise to make one or two clicks in the expander arm adjustment mechanism.
- Repeat the adjustment on the second cylinder on the same axis.
- Apply the brake.
- Wipe previous markings and measure piston rod stroke again.
- If the piston rod stroke is not within the correct operating range, repeat the adjustment.

Functional check

- After completing the adjustment, carry out a test drive.
- Perform several brakes. Stop the machine and check the temperature of the brake drums.
- If any drum is too hot, correct the brake adjustment and perform the test drive again.

SER.3.G-014.01.EN

6.25 LUBRICATION

ADVICE

Lubrication frequency (table Lubrication schedule of the machine):

D - working day (8 hours of trailer operation),

M - month

- Lubricate the machine with a hand or foot lubricator filled with the recommended lubricant. Remove old grease and other contaminants before starting work. Wipe off excess grease when finished.
- Wipe parts that should be lubricated with machine oil with a dry and clean cloth. Apply the oil to the surface with a brush or oiler. Wipe off excess oil.
- Have the grease in the bearings of the driving axle hubs replaced by a specialised service centre with the appropriate tools. Dismantle the entire hub, remove the bearings and individual sealing rings. After thorough washing and visual inspection, install the lubricated components. Replace bearings and seals if necessary.
- Dispose of empty grease or oil containers in accordance with the lubricant manufacturer's recommendations.

Table 6.7 Lubricants

| ITEM | Symbol | Description |
|------|--------|--|
| 1 | A | general purpose solid lubricant (lithium, calcium), |
| 2 | B | solid lubricant for heavily loaded parts with MoS ₂ or graphite additives |
| 3 | C | anti-corrosion spray |
| 4 | D | ordinary machine oil, silicone spray lubricant |

Table 6.8 Machine lubrication schedule

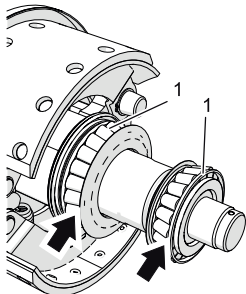
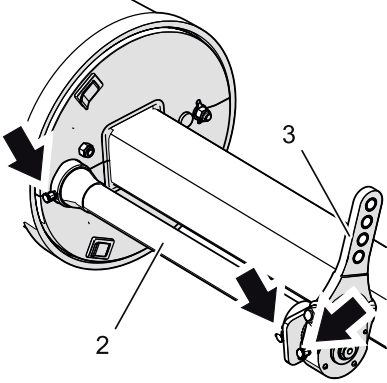
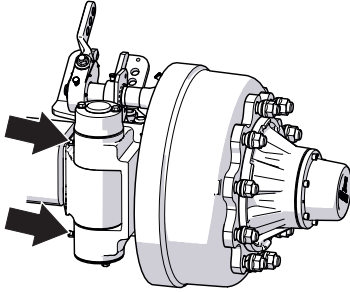
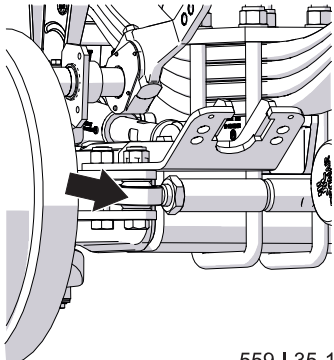
| Item | Name | Number of lubrication points | Type of grease | Frequency | |
|------|-----------------------------|------------------------------|----------------|-----------|---|
| 1 | Hub bearing (2 in each hub) | 4 | A | 24M |  <p>622-I.11a-1</p> |
| 2 | Spreader shaft sleeve | 8 | A | 3M |  |
| 3 | Spreader arm | 4 | A | 3M | |
| 4 | Axle knuckle pin | 4 | A | 3M |  <p>559-I.34-1</p> |
| 5 | Torsion axle ram bearings | 2 | A | 3M |  <p>559-I.35-1</p> |

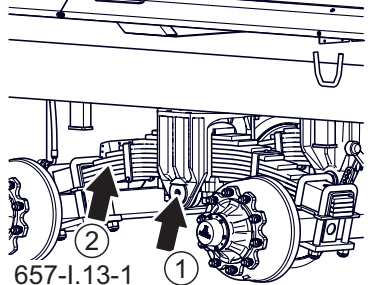
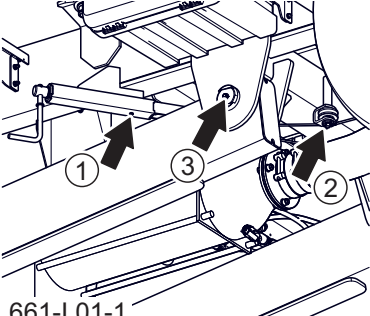
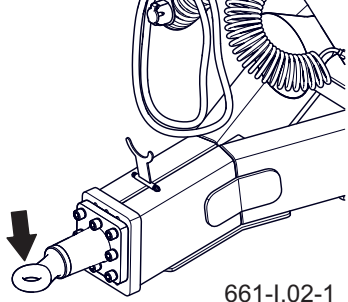
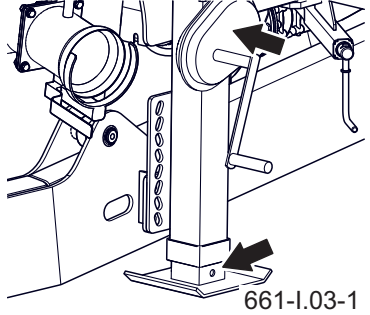
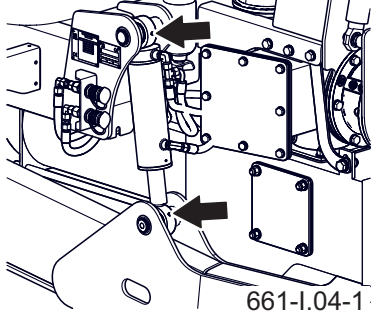
| Item | Name | Number of lubrication points | Type of grease | Frequency | |
|------|--------------------------------------|------------------------------|----------------|-----------|---|
| 6 | Rocker arm pin (1) | 2 | A | 3M |  <p>657-l.13-1</p> |
| | Spring feathers (2) | 4 | C | 1M | |
| 7 | Parking brake mechanism (1) | 1 | A | 6M |  <p>661-l.01-1</p> |
| | Parking brake guide roller pins (2) | 2 | A | 6M | |
| | Drawbar pin (3) | 2 | B | 1M | |
| 8 | Drawbar linkage | 1 | B | 14D |  <p>661-l.02-1</p> |
| 9 | Parking stand | 3 | A | 6M |  <p>661-l.03-1</p> |
| 10 | Drawbar suspension actuator bearings | 2 | A | 6M |  <p>661-l.04-1</p> |

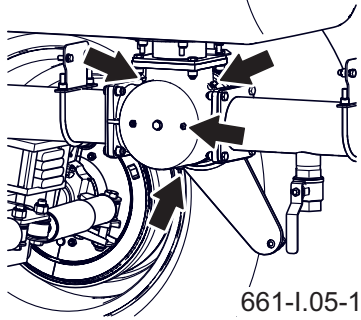
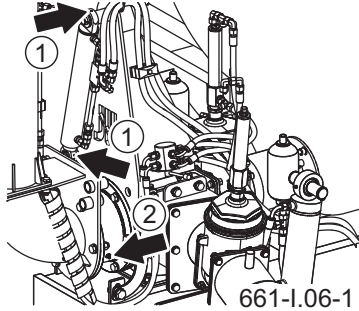
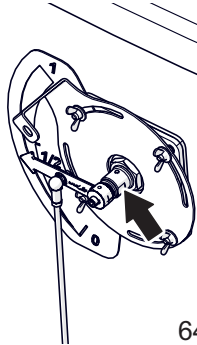
| Item | Name | Number of lubrication points | Type of grease | Frequency | |
|------|---|------------------------------|----------------|-----------|---|
| 11 | Three-way gate valve | 5 | A | 3M |  <p>661-I.05-1</p> |
| 12 | Docking mechanism actuator bearings (1) | 2 | A | 6M |  <p>661-I.06-1</p> |
| | Docking mechanism swivel joint | 1 | A | 6M | |
| 13 | Filling level indicator | 1 | A | 12M |  <p>649-7.04-1</p> |

SER.3.G-005.01.EN

6.26 MAINTENANCE OF ELECTRICAL INSTALLATION AND WARNING ELEMENTS



CAUTION

Driving with faulty lighting installation is prohibited. Damaged lighting must be replaced immediately before driving. Lost or damaged reflectors should be replaced with new ones.

Before leaving, make sure that all lamps and reflectors are clean.

ADVICE

The light source in the lamps are LED diodes and in the event of damage, they are replaced only as a complete lamp without the possibility of repair or regeneration.

Work related to the repair, replacement or regeneration of electrical installation components should be entrusted to specialized workshops that have appropriate technologies and qualifications to perform this type of work.

The user's duties include only technical inspection of the electrical installation and reflectors.

The scope of activities

Connect the machine to the tractor with a suitable connection lead.

Make sure the connection cable is OK. Check the connection sockets on the tractor and on the machine.

Check the completeness, technical condition and correct functioning of the machine lighting.

Check the wiring harness for damage (rubbed insulation, wire break, etc.). Check the completeness of lamps and all reflectors.

Check the correct installation of the triangular plate holder for slow moving vehicles.

Before travelling on a public road, make sure that the tractor has a reflective warning triangle.

SER.3.G-015.01.EN

6.27 CONSUMABLES



6.27.1 Hydraulic oil

ADVICE

In the hydraulic system of the machine, L-HL 32 LOTOS oil was used.

It is absolutely necessary to observe that the oil in the machine's hydraulic system and the tractor's hydraulic system is of the same type. If different types of oil are used, make sure that both hydraulic means can be mixed together. The use of different types of oil may cause damage to the trailer or agricultural tractor. The new machine is filled with L-HL32 Lotos hydraulic oil.

If you need to change the hydraulic oil for another, read the oil manufacturer's instructions carefully. If he recommends flushing the system with an appropriate preparation, follow these recommendations. It ensured that the chemicals used for this purpose do not act aggressively on the materials of the hydraulic system. During normal operation of the machine, it is not necessary to change the hydraulic oil, however, if necessary, this operation should be entrusted to specialist service centres.

Due to its composition, the oil used is not classified as a dangerous substance, however, long-term action on the skin or eyes may cause irritation. In the event of contact of oil with skin wash the area of contact

Table 6.9 Characteristics of the L-HL 32 oil

| Item | Name | Unit | |
|------|--|--------------------|-------------|
| 1 | Viscosity classification according to ISO 3448VG | - | 32 |
| 2 | Kinematic viscosity at 400°C | mm ² /s | 28.8 – 35.2 |
| 3 | Quality classification according to ISO 6743/99 | - | HL |
| 4 | Quality classification according to DIN 51502 | - | HL |
| 5 | Flash-point | C | 230 |

**DANGER**

Do not use water to extinguish a fire of oil!

with water and soap. Do not use organic solvents (petrol, kerosene). Dirty clothing should be removed to prevent oil from getting on your skin. If the oil gets into your eyes, flush them with plenty of water and in case of irritation contact your doctor.

Hydraulic oil under normal conditions is not harmful to the respiratory tract. There is only a risk when the oil is sprayed strongly (oil mist) or in the event of a fire where poisonous compounds may be released. In the event of fire, the oil must be extinguished with carbon dioxide, foam or extinguishing steam

6.27.2 Lubricants

ADVICE

Lubrication frequency (Table Trailer lubrication schedule).

For heavily loaded parts, it is recommended to use lithium grease with the addition of molybdenum disulphide (MOS₂) or graphite. For less loaded components, it is recommended to use general-purpose machine greases that contain anti-corrosive additives and are highly resistant to water washout. Similar properties should be characteristic of aerosol preparations (silicone lubricants, anti-corrosive lubricants). Before using lubricants, read the information leaflet for the selected product. Particularly important are safety rules and how to handle a given lubricant and how to dispose of waste (used containers, contaminated rags, etc.). The information leaflet (product card) store together with the grease.

SER.3.G-016.01.EN

6.28 TIRES

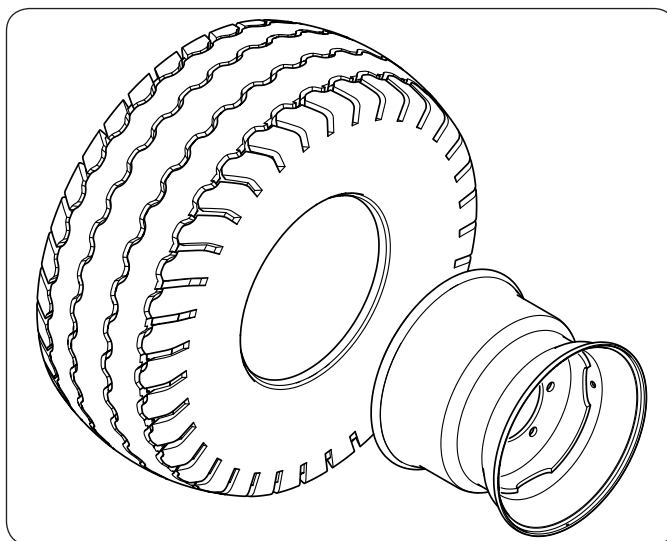

Table 6.10 Machine tires

| Item | Tire size | Disc wheel size | Air pressure in the tires |
|------|--------------------------|--------------------|---------------------------|
| 1 | 560/60- R22,5 161D 172A8 | 16.00x22,5; ET=+10 | 400kPa |
| 2 | 600/55- R26,5 165D 176A8 | 20.00x26,5; ET=0 | 400kPa |
| 3 | 650/55- R26,5 169D | 20.00x26,5; ET=0 | 400kPa |
| 4 | 650/65- R30,5 176D | 20.00x30,5; ET=+35 | 400kPa |
| 5 | 710/50- R30,5 173D | 24.00x30,5; ET=0 | 400kPa |
| 6 | 28L26 173A8 | ET=0 | 400kPa |
| 7 | | | |

SER.3.G-017.01.EN

6.29 FAULTS AND METHODS TO REMOVE THEM

Table 6.11 Faults and methods to remove them

| Fault | Cause | Removal method |
|---------------------------------------|---|--|
| Trouble with starting. | Braking system conduits not connected. | Connect the brake lines (applies to pneumatic systems). |
| | Damaged pneumatic system connection conduits. | Replace. |
| | Parking brake applied. | Apply the brake. |
| | Connections leak | Tighten, replace washers or sealing kits, replace wires. |
| | Defective control valve or brake force regulator. | |
| Low efficiency of the braking system. | System pressure too low. | Check the pressure on the manometer in the tractor, wait until the compressor fills the tank to the required pressure. Damaged air compressor in the tractor. Repair or replace. Damaged brake valve on the tractor. Repair or replace. Installation leak. Check systems for leaks. |
| Noise in the wheel axle hub. | Excessive clearance in the bearings. | Check the clearance and adjust if necessary |
| | Defective bearings. | Replace the bearings. |
| | Damaged hub components. | Replace. |
| Excessive heating of wheel axle hub. | Incorrectly adjusted main or parking brake. | Adjust the position of the expander arms. |
| | Worn brake linings. | Replace the brake shoes. |
| Incorrect hydraulic system operation. | Incorrect hydraulic oil viscosity. | Check the oil quality make sure that the oils in both machines are of the same grade. If necessary, change the oil in the tractor and/or trailer |

| | | |
|--|---|---|
| Incorrect hydraulic system operation. | Insufficient tractor hydraulic pump performance, tractor hydraulic pump defective.. | Check the hydraulic pump in the tractor. |
| | Damaged or dirty actuator. | Check the actuator piston rod (bending, corrosion), check the actuator for tightness (piston rod seal), repair or replace the actuator if necessary. |
| | The actuator is overloaded | Check and if necessary reduce the load on the actuator. |
| | Damaged hydraulic lines | Check and make sure that the hydraulic conduits are tight, not kinked and properly tightened. If necessary, replace or tighten. |
| Damaged articulated telescopic shaft. | Too big angular deviation during operation. | Use a wide-angle shaft or disconnect the PTO when turning. |
| | Shaft too short or too long. | Align the shaft according to the directions in the operator's manual provided by the shaft's manufacturer. |
| Excessive wear on both sides of the left and right shoulder of the tire. | Air pressure too low. Driving speed too high when cornering with a loaded trailer. Too fast loss of air due to a damaged rim, valve, puncture, etc. | Check the air pressure. Check the road tires for proper inflation regularly. Trailer load too high. Do not exceed the permissible total weight of the machine. Reduce travel speed when cornering on paved surfaces. Check the rim and valve. Replace damaged parts. |
| Excessive wear of the tire in the centre section. | Air pressure too high. | Check air pressure. Check the road tires for proper inflation regularly. |
| Excessive one-sided wear of the left or right shoulder tire. | Incorrect convergence. Driving axles incorrectly adjusted. | Damaged spring leaf on one side of the suspension. Replace the springs. |

| | | |
|---|---|--|
| Tread wear. | Damaged suspension system, broken spring. Damaged brake system, blocking of the brakes, incorrectly adjusted brake system. Too frequent and sudden braking. | Check the clearance in the suspension system, check the springs. Replace damaged or worn parts. Check the brake system for malfunction. Adjust the trailer levers. |
| Damage to the rim (hardening and cracking in the area of the rim), crumbling of the tire. | Incorrect braking technique. Too frequent sudden braking. Damaged braking system. | Check the braking system. Control the braking technique. The damage is caused by excessive heating of the hub and, as a result, of the road wheel rim. |
| The feed pump does not rotate | External object blockage. | Remove the external object. |
| | Medium dried during standstill | Clean the pump |
| | Too much solid matter | Pumped dilution medium |
| | The pump impeller does not rotate | Too high temperature of the pumped medium Wrong, aggressive medium |
| The pump does not suck in the medium | Incorrect direction of rotation of the drive shaft | Check the direction of rotation of the PTO drive shaft |
| | Suction valve closed | Open the suction valve |
| | Blocked suction line | Unclog the suction line Seal the suction line |
| | Pump not filled with liquid, pump impeller damaged | Avoid dry running, replace the pump impeller |
| | Excessive suction height | Correct the suction height |
| | Worn pressing elements | Replace impeller and impeller housing |
| The pump makes noise | Worn joints | Replace the joints |
| | Cavitation due to too high revolutions or too small a diameter of the suction line | Reduce the revs Increase the diameter of the suction pipe |

SER.3.G-018.01.EN

Chapter 7

Control panel

PRONAR TG214

7.1 CONTROL SYSTEM

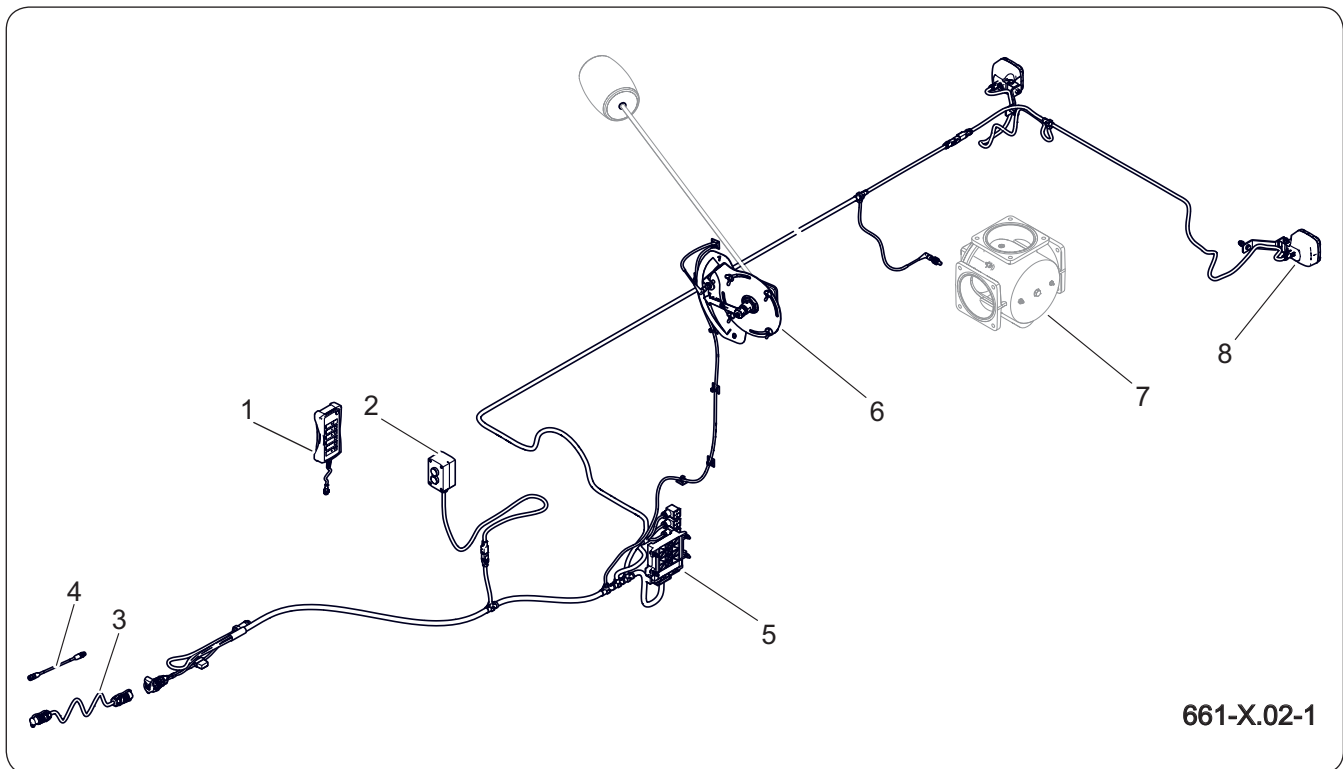

Figure 7.1 Arrangement of elements of the electrical control system

- (1) main remote control (2) additional remote control (3) 3pin connection cable
 (4) remote control connection cable (5) controller (6) indicator with sensor
 (7) gate valve with sensor (8) additional lighting



CAUTION

Fasten the pilot's control cable so that it does not get tangled in the driving system while driving and operating the PTO shaft.

Pay attention to the possibility of cutting or crushing the wiring harness at the point of entry of the cable by the elements of the cabin.

Remote controls powered by the tractor's electrical system via a 12V three-pin cable. Place the main remote control (1) in the tractor operator's cabin. On the other hand, attach the additional external remote control (2) to the flat surface of the machine with a magnet, allowing easy access to the remote control buttons.

7.1.1 Main control pilot

Table 7.1 Operation with the main remote control

| Function | Description |
|-------------|--|
| Aggregation | <p>Connect the three-pin power connector to the tractor's 12V socket.</p> <p>Activate the appropriate section on the tractor's external hydraulic manifold, supplying the machine's hydraulic system.</p> <p>Press the ON/OFF button - (1) figure 5.1)</p> |
| Filling | <p>Switch the two-position distributor - figure (5.3) to the appropriate work cycle - side loading (A) / docking mechanism (B) (if the slurry tanker is equipped with a docking mechanism).</p> <p>Activate the appropriate section on the tractor's external hydraulic manifold, supplying the machine's hydraulic system.</p> <p>Connect the suction pipe to the side loading mechanism or use buttons (5) and (6) to connect the docking mechanism (option).</p> <p>Press and hold the button (3) for 2 seconds (the LED flashes and turns on).</p> <p>Engage the PTO drive (pumping).</p> <p>Press the STOP button (2) - the mixing LED will light up or wait until the level sensor placed on the filling indicator switches the damper from suction to mixing.</p> <p>Off the PTO drive.</p> |
| Transport | <p>a) Mixing of cargo: Activate the appropriate section on the tractor's external hydraulic manifold, supplying the machine's hydraulic system.</p> <p>Engage the PTO drive.</p> <p>b) No cargo mixing: Turn off the tractor's hydraulic system.</p> <p>Off the PTO drive.</p> |
| Emptying | <p>Activate the appropriate section on the tractor's external hydraulic manifold, supplying the machine's hydraulic system.</p> <p>Press and hold the button (4) for 2 seconds (the LED flashes and turns on).</p> <p>Engage the PTO drive (pumping).</p> <p>After emptying the tank, press the STOP button (2) - the mixing diode will light up.</p> <p>Off the PTO drive.</p> |

7.1.2 Additional remote control

The additional remote control - figure (5.4) has a built-in magnet that facilitates the installation of the device on the steel structure of the machine. The two START and STOP buttons correspond respectively to the filling (3) and STOP (mixing) (2) buttons on the

ADVICE

First, apply pressure to the hydraulic system of the manifold, then activate the control pilot.

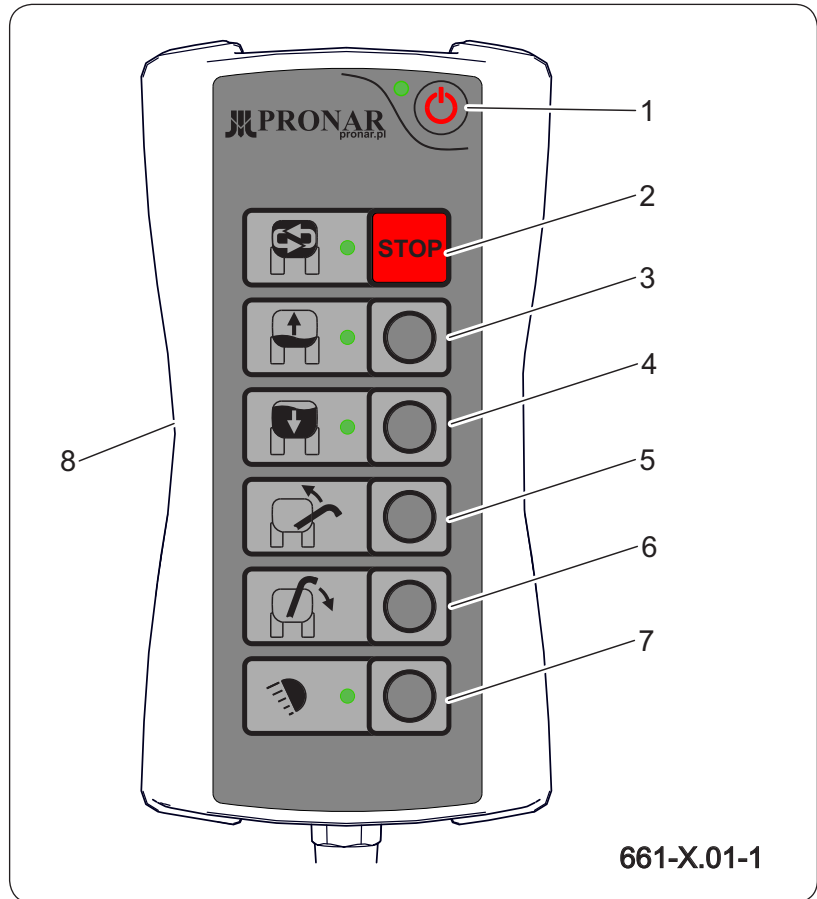

Figure 7.2 Main control pilot

- | | |
|-------------------------|-------------------|
| (1) power | (2) STOP (mixing) |
| (3) filling | (4) emptying |
| (5) lifting | (6) lowering |
| (7) additional lighting | (8) housing |

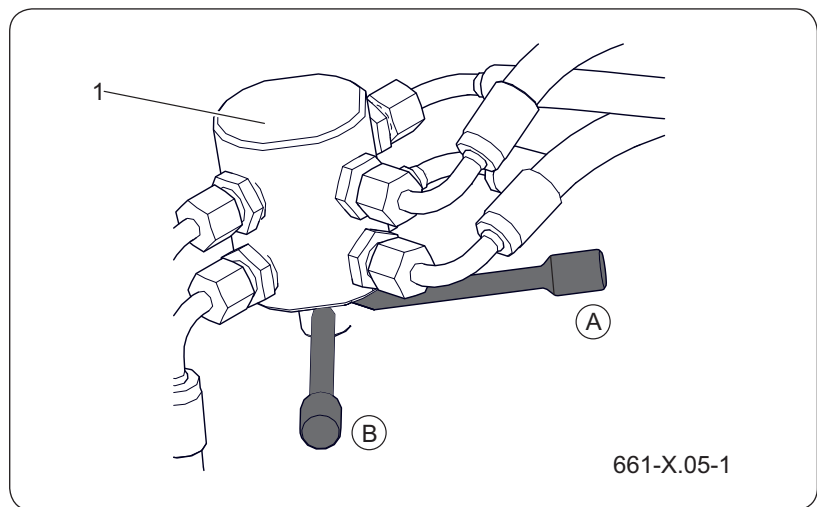

Figure 7.3 Two-position distributor

- | | |
|------------------|-------------------------------|
| (A) side loading | (2) loading docking mechanism |
| (3) distributor | |

ADVICE

The activity of the sensors, i.e. reading a nearby element, is signalled by a yellow LED.

Set the distance of the sensor from the approaching element to the value of 4 - 6mm.

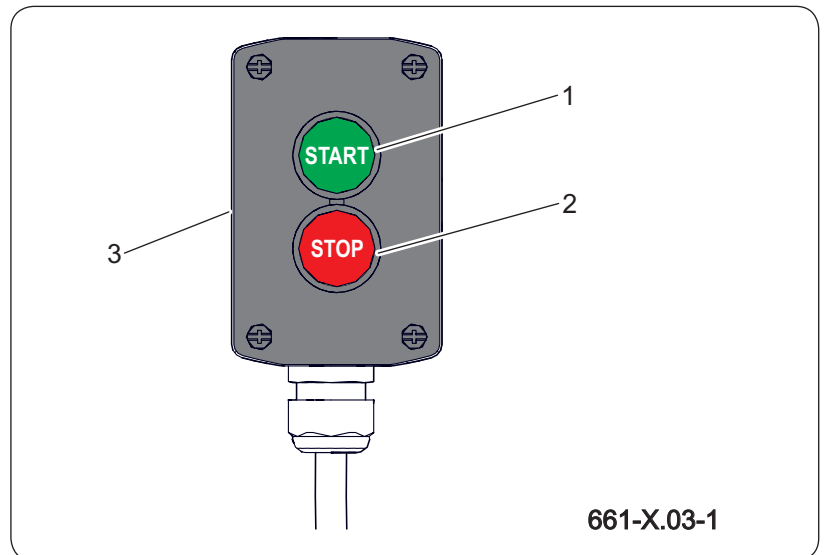

Figure 7.4 Additional remote control

(1) *START* button (2) *STOP* button
(3) *housing*

main remote control - figure (5.2).

The operation of the remote control is analogous to the main control device of the machine.

7.1.3 Inductive sensors

The opening status of the three-way gate valve and the filling of the tank are monitored by inductive sensors.

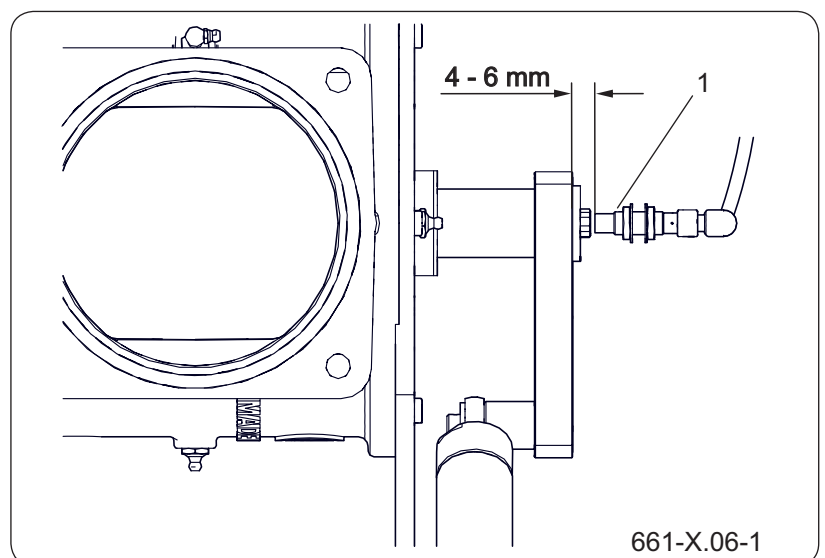

Figure 7.5 Three-way valve position sensor

(1) *inductive sensor*

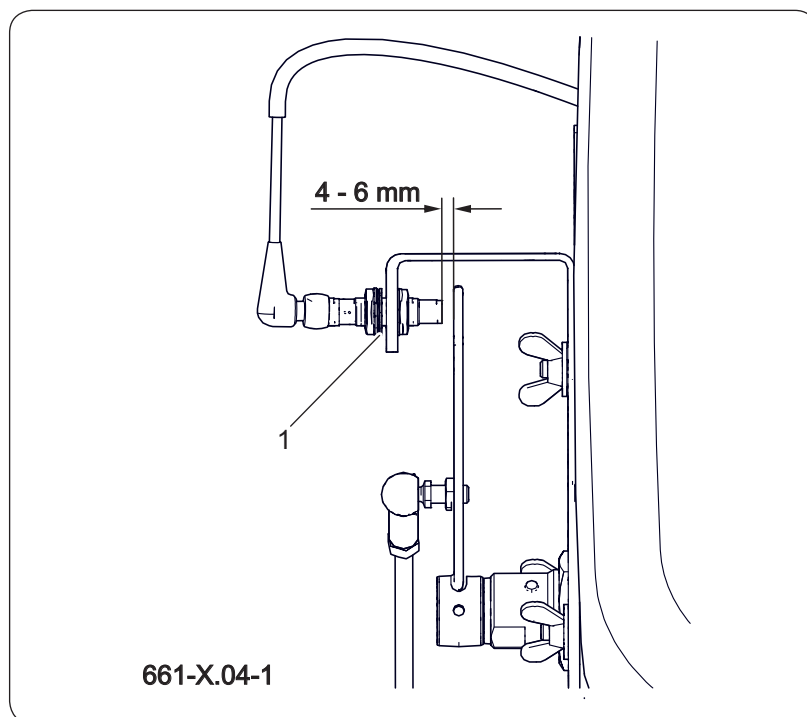

Figure 7.6 Fill indicator sensor
(1) inductive sensor

STR.3.G-001.01.EN

Chapter 8

Attachments and additional materials

PRONAR TG214

