



**PRONAR Sp. z o.o.**

17-210 NAREW, UL. MICKIEWICZA 101A, PODLASKIE PROVINCE

tel.:	+48 085 681 63 29	+48 085 681 64 29
	+48 085 681 63 81	+48 085 681 63 82
fax:	+48 085 681 63 83	+48 085 682 71 10

[www.pronar.pl](http://www.pronar.pl)

# OPERATOR'S MANUAL

## ROTARY TEDDER

### PRONAR PWP530

TRANSLATION OF THE ORIGINAL INSTRUCTIONS

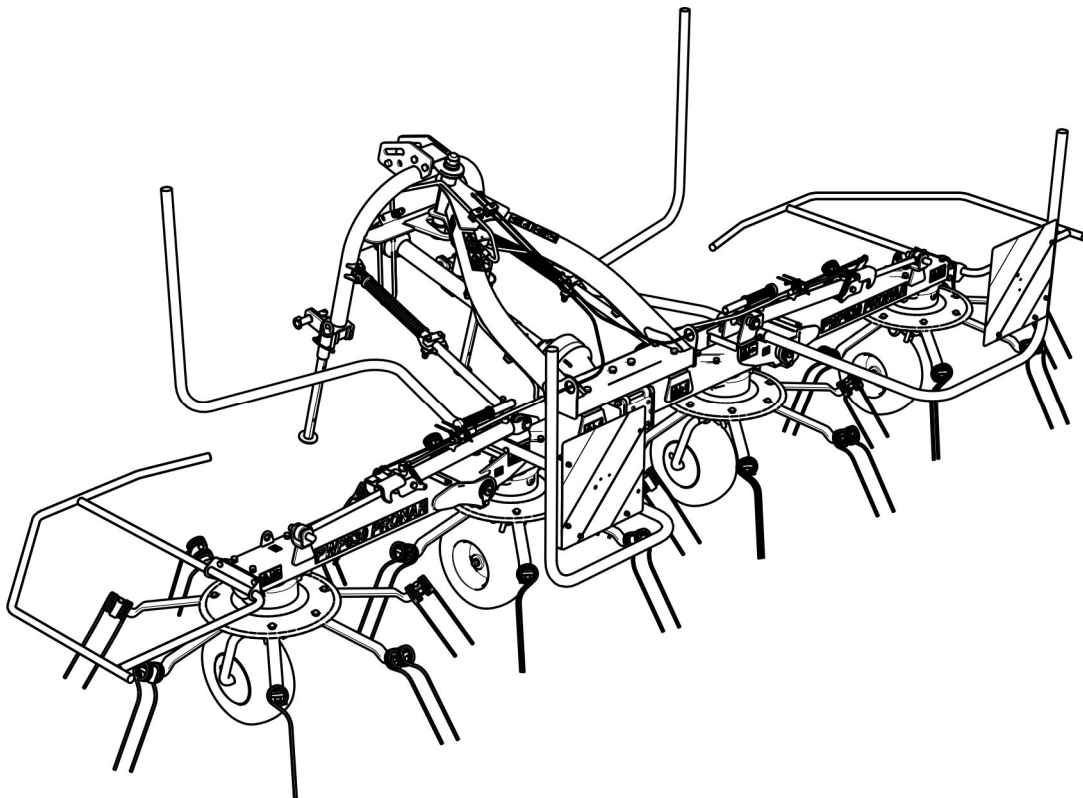

ISSUE 4A-12-2011

PUBLICATION NO 199N-00000000-UM

EN



# ROTARY TEDDER

## PRONAR PWP530

### MACHINE IDENTIFICATION

**SYMBOL /TYPE:** PWP530

**SERIAL NUMBER:**

--	--	--	--	--	--

# INTRODUCTION

Information contained herein is current at date of publication. As a result of improvements, some numerical values and illustrations contained in this publication may not correspond to the factual specification of the machine supplied to the user. The manufacturer reserves the right to introduce design changes in machines produced that facilitate operation and improve the quality of their work, without making minor amendments to this Operator's Manual. Please send your comments and proposals on the design and operation of the machine to the manufacturer. This information enables objective evaluation of the machines produced and provides indications for their further improvement. Information on significant design changes is passed on to users on information inserts attached to this Operator's Manual (annexes).

This Operator's Manual is an integral part of the machine's documentation. Before using the machine, the user must carefully read this Operator's Manual and observe all recommendations. This guarantees safe operation and ensures malfunction free work of the machine. The machine is designed to meet obligatory standards, documents and legal regulations currently in force.

The manual describes the basic safety rules and operation of PWP530 rotary tedder. If the information contained in the Operator's Manual needs clarification then the user should refer for assistance to the sale point where the machine was purchased or to the manufacturer.

Manufacturer's address:

PRONAR Sp. z o.o.

ul. Mickiewicza 101A

17-210 Narew

Contact telephones

+48 085 681 63 29

+48 085 681 64 29

+48 085 681 63 81

+48 085 681 63 82

Information, descriptions of danger and precautions and also recommendations and orders associated with user safety instructions are marked:



and also preceded by the word "**DANGER**". Failure to observe the instructions may endanger the machine operator's or other person's health or life.

Particularly important information and instructions, the observance of which is essential, are distinguished in the text by the sign:



and also preceded either word "**ATTENTION**". Failure to observe the instructions may lead to damage to the machine as a result of improper operation, adjustment or use.

In order to focus the user's attention on the need to perform maintenance, the relevant section of the Operator's Manual is marked with the pictogram:







**PRONAR Sp. z o.o.**  
ul. Mickiewicza 101 A  
17-210 Narew, Polska  
tel./fax (+48 85) 681 71 00,  
fax (+48 85) 681 63 83  
<http://www.pronar.pl>  
e-mail: [pronar@pronar.pl](mailto:pronar@pronar.pl)



## EC Declaration of Conformity

PRONAR Sp. z o.o. declares, with full responsibility, that the machine:

Machine description and identification data	
General description and purpose:	<b>Rotary Tedder</b>
Type:	<b>PWP530</b>
Model:	—
VIN number:	
Commercial name:	<b>Rotary Tedder PRONAR PWP530</b>

referred to in this declaration meets the requirements of the Directive **2006/42/EC** of The European Parliament and of The Council of 17 May 2006 on machinery

The machine has been designed for and meets the requirements of the following standards:

**PN-EN ISO 12100, PN-EN ISO 4254-10**

This declaration applies exclusively to the machine in the condition, in which it was sold and does not include components or parts added or subsequent modifications made by the final user.

The operator's manual is an integral part of the machine.

The Implementation Department Manager of PRONAR Sp. z o.o., 17-210 Narew, ul. Mickiewicza 101A is authorised to provide the technical documentation.

Narew, on 2022-01-10  
Date and place issued

Z-CIA PRYMOKORNA  
d/s technicznych  
członkowi zarządu  
  
**Roman Smoliniuk**  
Full name of the authorised person, position,  
signature

PRONAR Spółka z o.o.  
17-210 Narew ul. Mickiewicza 101A  
Tel: (+48) 681 63 29, 681 72 54  
Fax: (+48) 681 63 83  
NIP 543-03-00-929, KRS 000139188





# TABLE OF CONTENTS

<b>1</b>	<b>BASIC INFORMATION</b>	<b>1.1</b>
1.1	IDENTIFICATION	1.2
1.2	PROPER USE	1.3
1.3	EQUIPMENT	1.4
1.4	WARRANTY TERMS	1.4
1.5	TRANSPORT	1.5
1.6	ENVIRONMENTAL HAZARDS	1.8
1.7	WITHDRAWAL FROM USE	1.8
<b>2</b>	<b>SAFETY ADVICE</b>	<b>2.1</b>
2.1	BASIC SAFETY RULES	2.2
2.2	DRIVING ON PUBLIC ROADS	2.6
2.3	DESCRIPTION OF MINIMAL RISK	2.7
2.4	INFORMATION AND WARNING DECALS	2.8
<b>3</b>	<b>DESIGN AND OPERATION</b>	<b>3.1</b>
3.1	TECHNICAL SPECIFICATION	3.2
3.2	ROTARY TEDDER DESIGN	3.2
3.3	HITCHING SYSTEM	3.4
3.4	OPERATING PRINCIPLE	3.6
<b>4</b>	<b>CORRECT USE</b>	<b>4.1</b>
4.1	PREPARING FOR WORK BEFORE FIRST USE	4.2
4.2	CHECKING TECHNICAL CONDITION OF TEDDER	4.4
4.3	ATTACHING TO TRACTOR	4.5
4.4	PREPARATION OF TEDDER FOR WORK	4.7
4.4.1	SETTING FROM TRANSPORT POSITION TO WORKING POSITION	4.7
4.4.2	SETTING WORKING POSITION	4.9
4.5	CONNECTING DRIVESHAFT	4.12
4.6	TEDDING	4.13
4.7	DISCONNECTING THE TEDDER	4.15
4.8	PREPARATION OF TEDDER FOR TRANSPORT	4.15
4.9	LIGHTING INSTALLATION AND ADDITIONAL MARKING (OPTIONAL)	4.17

4.9.1	CONSTRUCTION	4.17
4.9.2	USAGE AND MAINTENANCE	4.19

## **5 MAINTENANCE 5.1**

5.1	SAFE MAINTENANCE PRINCIPLES	5.2
5.2	OPERATION OF MAIN TRANSMISSION	5.2
5.3	OPERATION OF HYDRAULIC SYSTEM	5.4
5.4	STORAGE	5.5
5.5	LUBRICATION	5.6
5.6	CHECKING AND REPLACEMENT OF SPRINGTINES	5.9
5.7	TIGHTENING TORQUE FOR NUT AND BOLT CONNECTIONS	5.11

**SECTION**

**1**

**BASIC INFORMATION**

IDENTIFICATION

PROPER USE

EQUIPMENT

WARRANTY TERMS

TRANSPORT

ENVIRONMENTAL HAZARDS

WITHDRAWAL FROM USE

# 1.1 IDENTIFICATION

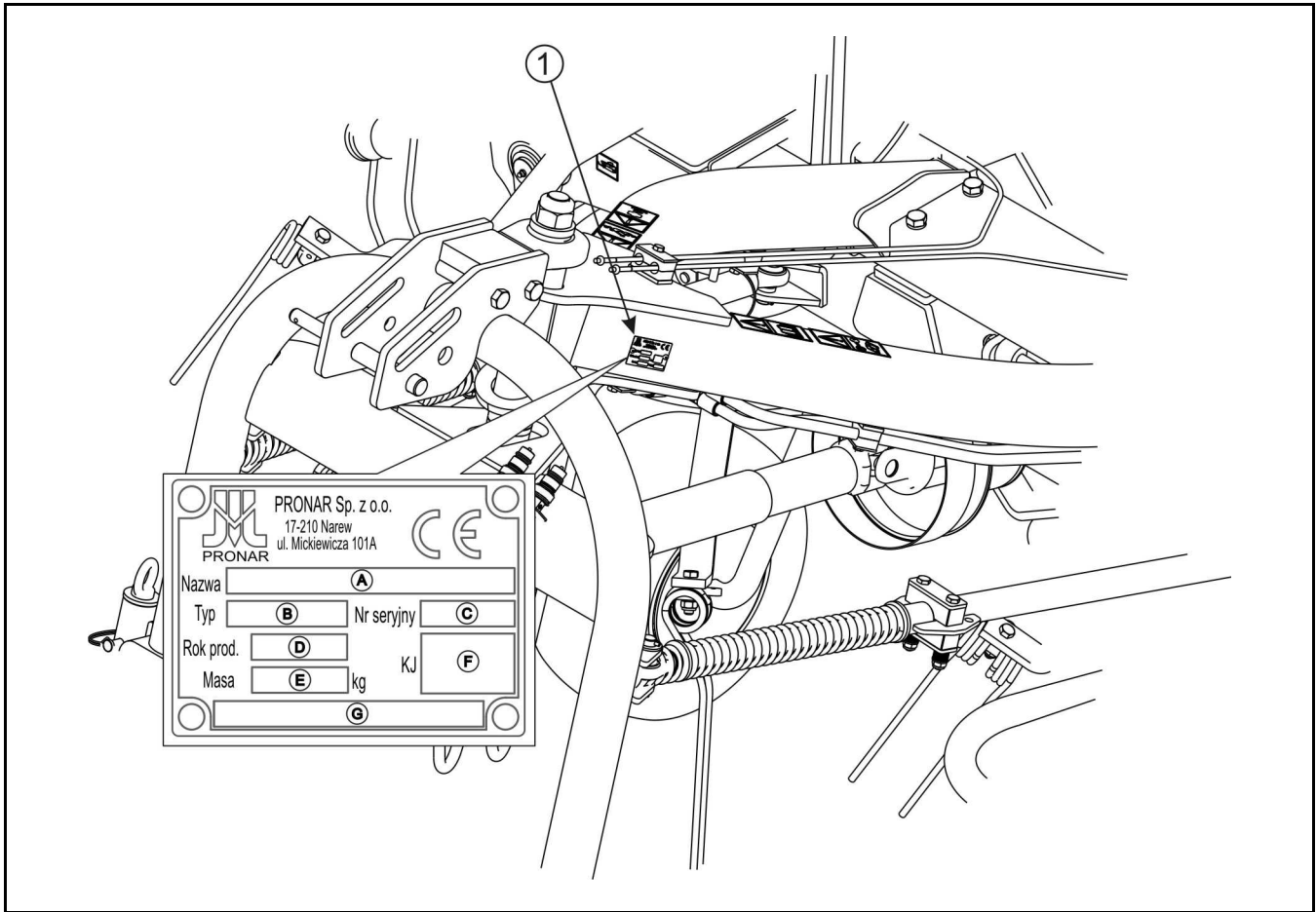

**FIG. 1.1A** Location of the data plate

(1) data plate

The PWP530 rotary tedder is marked with a data plate (1), placed on left side of machine's lifting arm. When buying the rotary tedder check that the serial numbers on the machine agree with the number written in the *WARRANTY BOOK, IN THE SALES DOCUMENTS AND IN THE* Operator's Manual.

The meaning of the individual fields found on the data plate are presented in the table below:

- |                             |                             |
|-----------------------------|-----------------------------|
| A – Machine name            | B – Type                    |
| C – Serial number           | D – Production year         |
| E – Total weight            | F – Sign of quality control |
| G – Machine name, continued |                             |

## 1.2 PROPER USE

Rotary tedder is designed for agricultural work: turning cut swaths (straw, grass, hays) on stone free grassland with a level surface. Do NOT use the machine for any other purpose. Using it as intended also involves all actions connected with the safe and proper operation and maintenance of the machine. Due to the above, the user is obliged to:

- carefully read this publication and the PTO shaft Operator's Manual and adhere to the recommendations contained in these documents,
- understand the operating principle of the machine's operation and of its safe and proper use,
- comply with general safety regulations while working,
- prevent accidents,
- comply with road traffic regulations.

**TAB. 1.1 THE AGRICULTURAL TRACTOR'S REQUIREMENTS**

CONTENTS	MEASURED AS	REQUIREMENTS
<b>Rear three-point linkage</b> Category	-	I or II
<b>Power take-off shaft</b> Rotation speed Type / number of PTO splines	RPM -	540 1 3/8" / 6
<b>Other requirements</b> Minimum power demand	kW / Horsepower	22.1 / 30

Do NOT perform unauthorised repairs and modifications to the tedder as this shall be treated by the Manufacturer as misusing the machine.

The machine may only be used by appropriately trained users, who are aware of the dangers, construction and operating principles of the tedder. Repairs to the machine shall only be made by qualified personnel (in the guarantee period all repairs must be performed in

the guarantee service, indicated by the Manufacturer). Maintenance and repairs that can be performed by the user, are described in section 5.

	<p><b>IMPORTANT!</b></p> <p>The tedder must not be used for purposes other than those for which it is intended.</p>
---	---

## 1.3 OPTIONAL EQUIPMENT

**TAB. 1.2 PWP530 ROTARY TEDDER ACCESSORIES**

EQUIPMENT	STANDARD	OPTION
<i>OPERATOR'S MANUAL</i>	•	
<i>WARRANTY BOOK</i>	•	
PTO shaft (complete)	•	

Recommended PTO shafts:

- 7102131CE007136 B&P,
- 1620-6200-131-03 Weasler,
- T201310EN112U34 Comer.

## 1.4 WARRANTY TERMS

The manufacturer guarantees the reliable operation of the machine when it is used according to its intended purpose as described in the *OPERATOR'S MANUAL*. Faults discovered during the warranty period will be repaired by the Warranty Service. Repair deadline is given in warranty booklet.

The guarantee does not apply to those parts and sub-assemblies of the machine, which are subject to wear in normal usage conditions, regardless of the warranty period. Consumables include the following parts/sub-assemblies:

- tyres,
- spring tine fingers,
- bearings.

The warranty service only applies to such cases as: mechanical damage which is not the user's fault, factory defects of parts, etc.

In the event of damage arising from:

- mechanical damage which is the user's fault, caused by road accidents,
- by inappropriate use, adjustment or maintenance, use of the tedder for purposes other than those for which it is intended,
- operating a damaged tedder,
- repairs carried out by unauthorised persons, improperly carried out repairs,
- arbitrary and wilful adjustments to the tedder's structure,

the user will lose the right to warranty service.

The user is obliged to report immediately on noticing any wear in the paint coating or traces of corrosion, and to have the faults rectified whether they are covered by the guarantee or not. Detailed guarantee regulations are contained in the *WARRANTY BOOK* attached to each machine.



### **ATTENTION!**

**Demand that the seller carefully and precisely fills out the *WARRANTY BOOK* and guarantee repair coupons. A missing date of purchase or sale point stamp, may make the user ineligible for any warranty repair or refund.**

## **1.5 TRANSPORT**

The tedder is ready for sale in a completely assembled state and does not require packing. Packing is only required for the machine operator's manual and its technical documentation.



## **ATTENTION!**

**When transporting independently, the user must carefully read this operator's manual and observe its recommendations. When being transported on a motor vehicle the tedder must be mounted on the vehicle's platform in accordance with the transport safety requirements. The driver of the vehicle should take particular care while driving.**

Supply to user takes place by transport vehicle. Transport of the tedder is permissible connected to a tractor provided the tractor's driver familiarises himself with the machine's Operator's Manual and particularly with information concerning safety and principles of connection and transport of tedder on public roads. Do NOT drive the tractor with tedder connected when visibility is limited.

When loading and unloading the tedder, comply with the general principles of workplace health and safety for reloading work. Persons operating reloading equipment must have the qualifications required to operate these machines.

The tedder should be attached to lifting equipment in places shown on figure (1.2A), i.e. to transport lug (1) and central connection pin (2). Securing point is marked with information decal. It is recommended that during transport of the tedder it is set in transport position (see section 4.8 PREPARATION OF TEDDER FOR TRANSPORT) In the event that cable or strap of transloading equipment may be caught by protruding machine elements placed in transport position, dismantle them. When raising the tedder take particular care due to the possibility of tipping over the machine and the risk of injuries from protruding machine parts.



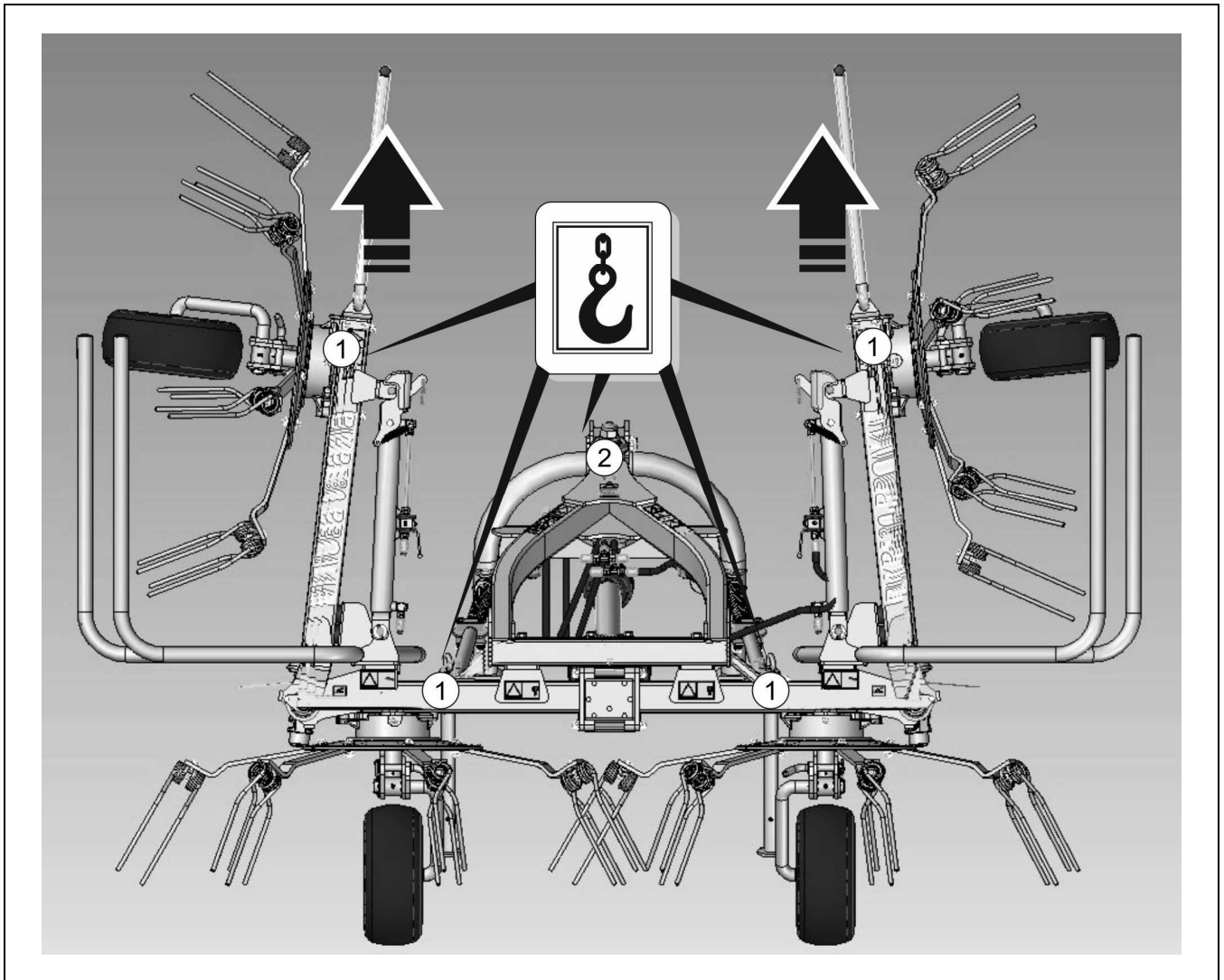

**FIG. 1.2A**      **Points of tedder suspension**

*(1) transport lug (2) central connection pin*



**DANGER**

**During loading, tedder should be placed in transport position.**

The machine should be attached firmly to the platform of the vehicle using straps or chains fitted with a tightening mechanism. The fastening equipment used must have a valid safety certificate. Wedges or other objects without sharp edges should be placed under the wheels of the tedder to prevent it from rolling. The wedges must be fixed to the platform of the vehicle. During reloading work, particular care should be taken not to damage parts of the tedder's fittings or the paint coat.

## **1.6 ENVIRONMENTAL HAZARDS**

A hydraulic oil leak from the main gear constitutes a direct threat to the natural environment owing to its limited biodegradability. While carrying out maintenance and repair work, which involves the risk of an oil leak, this work should take place on an oil resistant floor or surface. In the event of oil leaking into the environment, first of all contain the source of the leak, and then collect the leaked oil using available means. Remaining oil should be collected using sorbents, or by mixing the oil with sand, sawdust or other absorbent materials. The oil pollution, once gathered up, should be kept in a sealed, marked, hydrocarbon resistant container, and then passed on to the appropriate oil waste recycling centre. The container should be kept away from heat sources, flammable materials and food.

Oil which has been used up or is unsuitable for further use owing to a loss of its properties should be stored in its original packaging in the conditions described above.

## **1.7 WITHDRAWAL FROM USE**

Should the user decide to withdraw the machine from use, the entire tedder should be taken to a scrap yard. When spare parts are changed, worn out or damaged parts should be taken to a collection point for recyclable raw materials. Hydraulic oil should be taken to the appropriate facility dealing with the re-use of this type of waste.

**SECTION**

# **2**

## **SAFETY ADVICE**

BASIC SAFETY RULES

DRIVING ON PUBLIC ROADS

DESCRIPTION OF MINIMAL RISK

INFORMATION AND WARNING DECALS

## 2.1 BASIC SAFETY RULES

- Before using the tedder the user should carefully read this Operator's Manual and the PTO shaft Operator's Manual and adhere to the recommendations contained in these documents.
- The tedder may only be used and operated by persons qualified to drive and trained in the use of agricultural tractors.
- If the information contained in the Operator's Manual is difficult to understand, contact a seller who runs an authorised technical service on behalf of the manufacturer, or contact the manufacturer directly.
- Careless and improper use and operation of the tedder, and non-compliance with the recommendations included in this operator's manual is dangerous to your health.
- Be aware of existence of a minimal risk, and for this reason the fundamental basis for using this machine should be the application of safety rules and sensible behaviour.
- The machine must never be used by persons who are not authorised to drive agricultural tractors, including children and people under the influence of alcohol or other drugs.
- Non-compliance with the safety rules of this Operator's Manual can be dangerous to the health and life of the operator and others.
- The tedder must not be used for purposes other than those for which it is intended. Anyone who uses the machine other than the way intended takes full responsibility for himself for any consequences of this use.
- Any modification to the machine frees the manufacturer from any responsibility for damage or detriment to health which may arise as a result.
- Before each use of the tedder check its technical condition. In particular check the technical condition of the hitching system, drive system, mounting of arms, tedding springtines and protective guards.

- Tedder disconnected from tractor must be supported by supports and secured against rolling away by using wheel wedges or other elements without sharp edges.
- Do NOT ride on the tedder or transport any materials on it.
- The machine may only be used when all the safety guards and other protective elements are technically sound and correctly positioned. In the event of loss or destruction of the safety guards, they must be replaced with new ones.
- The machine must not be used when not in working order.
- While reversing and during turns, the tedder drive must be disengaged.
- Do NOT leave the tractor cab, when the machine drive is engaged.
- Do NOT stand within the tedder's working zone.
- Before hitching the machine to the tractor, check the technical condition of the hitching system of the tedder and the tractor.
- Be especially careful when attaching the machine to the tractor..
- When reversing the tractor, there must be nobody between the tedder and the tractor.
- To attach the machine to the tractor only the rear Three-Point Linkage System may be used. After mounting the machine, check the safeguards.
- Use PTO shaft recommended by the Manufacturer.
- The tedder may not be used or transported in conditions of limited visibility.
- when preparing the tedder of the transport check if the tipping cylinder mechanical interlocks are properly engaged and if hydraulic cylinder valves are in CLOSED position.
- The PTO shaft has markings on the casing, indicating which end of the shaft shall be connected to the tractor.
- Never use a damaged PTO shaft, it may cause an accident. A damaged shaft must be repaired or replaced.

- Disconnect the drive shaft each time when it is not necessary to drive the machine, or when the tractor and tedder are at an unsuitable angle to each other.
- The chains preventing the shaft cover from turning while the shaft is working, shall be secured to a fixed element of tedder structure.
- Do NOT use the securing chains to support the shaft while machine is parked or when transporting the tedder.
- Before using the machine the user should thoroughly acquaint himself with the PTO shaft Operator's Manual and adhere to the recommendations contained in it.
- The tedder may only be connected to the tractor by appropriately selected PTO shaft recommended by the Manufacturer.
- The driveshaft must be equipped with a cover. Do NOT use the shaft with damaged or missing guards.
- After connecting shaft ensure that it is correctly and safely connected to the tractor and to the tedder.
- Before starting the tedder make sure that there are no bystanders (especially children) or animals in the danger zone (an area with a radius of up to 50 m from the tedder). The machine operator is obliged to ensure proper visibility of the machine and the working area.
- While tedding apply working speed recommendations.
- When tedding on the edges of streets, public roads, on stony ground there is a risk that thrown out stones and foreign bodies may pose a risk to bystanders and other vehicle passing by.
- When using the tedder and power takeoff shaft, do not use PTO rotation speed greater than 540 rpm. Do NOT overload shaft and tedder and also engage the clutch suddenly. Before starting PTO shaft make certain that the PTO rotation direction is correct.
- During tedding use the correct working position.

- Before disconnecting the shaft, turn off the tractor engine and remove the key from the ignition.
- Reduce pressure prior to disconnecting the hydraulic system.
- When working on the tyres, wedges or other objects without sharp edges should be placed under the wheels of the tedder to prevent it from rolling.
- Repair work on the wheels or tyres should be carried out by persons trained and entitled to do so. This work should be carried out using appropriate tools.
- In order to reduce the danger of fire the machine must be kept in a clean condition.
- In the event of work requiring the tedder to be raised, use properly certified hydraulic or mechanical lifts for this purpose. After lifting the machine, stable and durable supports must also be used. Work must not be carried out under a machine which has only been raised with a lift jack.
- The machine must not be supported using fragile elements (bricks or concrete blocks).
- Check the tyre pressure regularly.
- In the event of any fault or damage whatsoever, do not use the tedder until the fault has been corrected. The machine must not be used when not in working order.
- When operating the machine wear protective gloves and use the appropriate tools.
- Servicing and repair work should be carried out in line with the general principles of workplace health and safety. In the event of injury, the wound must be immediately cleaned and disinfected. In the event of more serious injuries, seek a doctor's advice.
- Repair, maintenance and cleaning work should be carried out with the tractor's engine switched off and the ignition key removed.
- Regularly check the condition of the screw and nut connections.

- The paint coating should be cleaned off before beginning welding work. Burning paint fumes are poisonous for people and animals. Welding work should be carried out in a well lit and well ventilated space.
- During welding work pay attention to flammable or fusible elements. If there is a risk that they will catch fire or be damaged, they should be removed or covered with non-flammable material before commencing welding work. The tedder must be disconnected from the tractor before commencing electric welding.
- During the warranty period, any repairs may only be carried out by a Warranty Service authorised by the manufacturer.
- Should it be necessary to change individual parts, use only those parts indicated by the manufacturer. Non-adherence to these requirements may put the user and other people's health and life at risk, and also damage the machine.
- After completing work associated with lubrication, remove excess oil or grease.
- Do NOT wear loose clothing, straps or whatever may become wrapped round the rotating drive shaft. Contact with rotating PTO shaft may cause severe injuries.
- Do NOT go over and under the shaft or stand on it equally during work as also when the machine is parked.

## **2.2 DRIVING ON PUBLIC ROADS**

- When driving on public roads, respect the road traffic regulations.
- Do not exceed the maximum speed when travelling. Adjust your speed to the road conditions.
- Before beginning travel, the tedder must be placed in transport position and raised using the rear three-point linkage system. When parked, the tedder should be lowered.
- Do NOT leave tractor driver's seat when the tractor is moving.



## 2.3 DESCRIPTION OF MINIMAL RISK

Pronar Sp. z o. o. in Narew has made every effort to eliminate the risk of accidents. There is, however, a certain minimal risk which could lead to an accident, and this is connected mainly with the actions described below:

- using the tedder for purposes other than those for which it is intended,
- being between the tractor and the tedder while the engine is running and when the machine is being attached,
- being on the machine while the engine is running,
- operating the tedder with removed or faulty safety guards,
- not keeping a safe distance from the danger zone or being within the zones while the tedder is operating,
- operation of the tedder by persons under the influence of alcohol,
- cleaning, maintenance and technical checks of the tedder.
- using unreliable PTO shaft.



The minimal risk may be kept to a minimum by following the recommendations below:



- prudent and unhurried operation of the machine,
- sensible application of the remarks and recommendations contained in the Operator's Manual,
- keeping a safe distance from forbidden or dangerous places,
- a ban on being on the machine when it is operating,
- carrying out repair and maintenance work in line with operating safety rules,
- carrying out repair and maintenance work by persons trained to do so,
- using strictly suited protective clothing,
- ensuring unauthorised persons have no access to the machine, especially children.

## **2.4 INFORMATION AND WARNING DECALS**

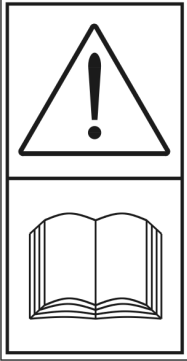
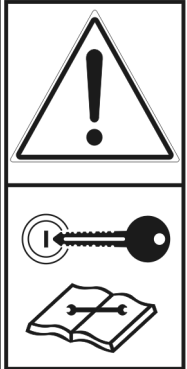
The tedder is marked with information and warning decals referred to in table (2.1). The symbols are positioned as presented in figure (2.1A). Throughout the time it is in use, the user of the machine is obliged to take care that notices and warning and information symbols located on the tedder are clear and legible. In the event of their destruction, they must be replaced with new ones. Safety decals are available from your PRONAR dealer or directly from PRONAR customer service. New assemblies, changed during repair, must be labelled once again with the appropriate safety signs.

**TAB. 2.1 INFORMATION AND WARNING DECALS**

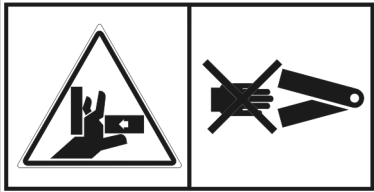
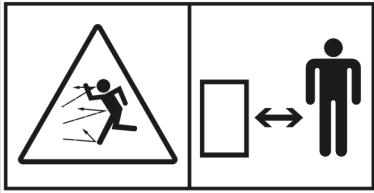
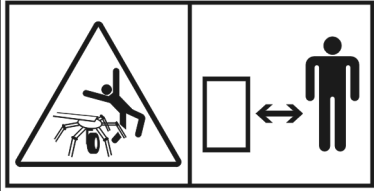
ITEM	SAFETY SYMBOL	DESCRIPTION
1		<p>Before starting work, carefully read the Operator's Manual.</p>
2		<p>Before beginning servicing or repairs, switch off engine and remove key from ignition</p>
3		<p>Danger associated with the rotating PTO shaft.</p>
4		<p>Maximum allowable PTO shaft rotation speed is 540 rpm.</p>

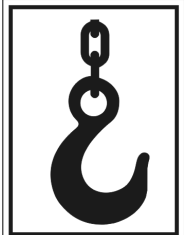
ITEM	SAFETY SYMBOL	DESCRIPTION
5		<p>Danger of crushing or severing of limbs. Be careful while folding and unfolding lateral guards.</p>
6		<p>Thrown out objects, endanger the whole body. Keep a safe distance from machine when tedder is in operation.</p>
7		<p>Danger of being struck by rotating elements of the machine. Keep a safe distance from raking assembly.</p>
8		<p>Risk of injury when machine is being arranged in transport or working position.</p>
9	<p><b><i>PWP530 PRONAR</i></b></p>	<p>Tedder type.</p>
10		<p>Transport catch point marking.</p>





*SECTION*

# 3

## **CONSTRUCTION AND OPERATING PRINCIPLES**

TECHNICAL SPECIFICATION  
ROTARY TEDDER DESIGN  
HITCHING SYSTEM  
OPERATING PRINCIPLE

## 3.1 TECHNICAL SPECIFICATION

**TAB. 3.1 ROTARY TEDDER TECHNICAL DATA**

<b>CONTENTS</b>	<b>UNIT</b>	<b>PWP530</b>
<b>Dimensions</b>		
Total length	mm	2550
Width in working setting	mm	5650
Width in transport setting	mm	2990
Height in working setting	mm	1810
Height in transport setting	mm	3100*
<b>Technical specification</b>		
Number of rotors	item	4
Number of working arms on rotor	item	7
Working width	mm	5300
Minimum tractor power demand	hp	30
Maximum PTO speed	RPM	540
Weight with PTO shaft	kg	685
Work output	ha/h	5.3
Recommended working speed	km/h	10
Noise emission level	dB	below 70
Adjustment of rotor inclination	°	13-19
<b>Tyres</b>		
Tyre	-	16x6.5-8
Air pressure in the tyres	kPa	160

\*- the height of the lower link axles from the ground ~ 850 mm

## 3.2 ROTARY TEDDER DESIGN

The rotary tedder design is shown in figure (3.1A). The main subassembly of the whole machine is the bearing frame connected to the system mounting the machine to the Three Point Linkage of the tractor, category I or II using ball and socket joint. The bearing frame is protected against mechanical shocks by two vibration absorbers placed between the frame and the tractor's three point linkage. In the central part of the bearing frame is the main



transmission (10) of the working assemblies, which drives the transmission of the rotors through the drive shafts placed in the frame.

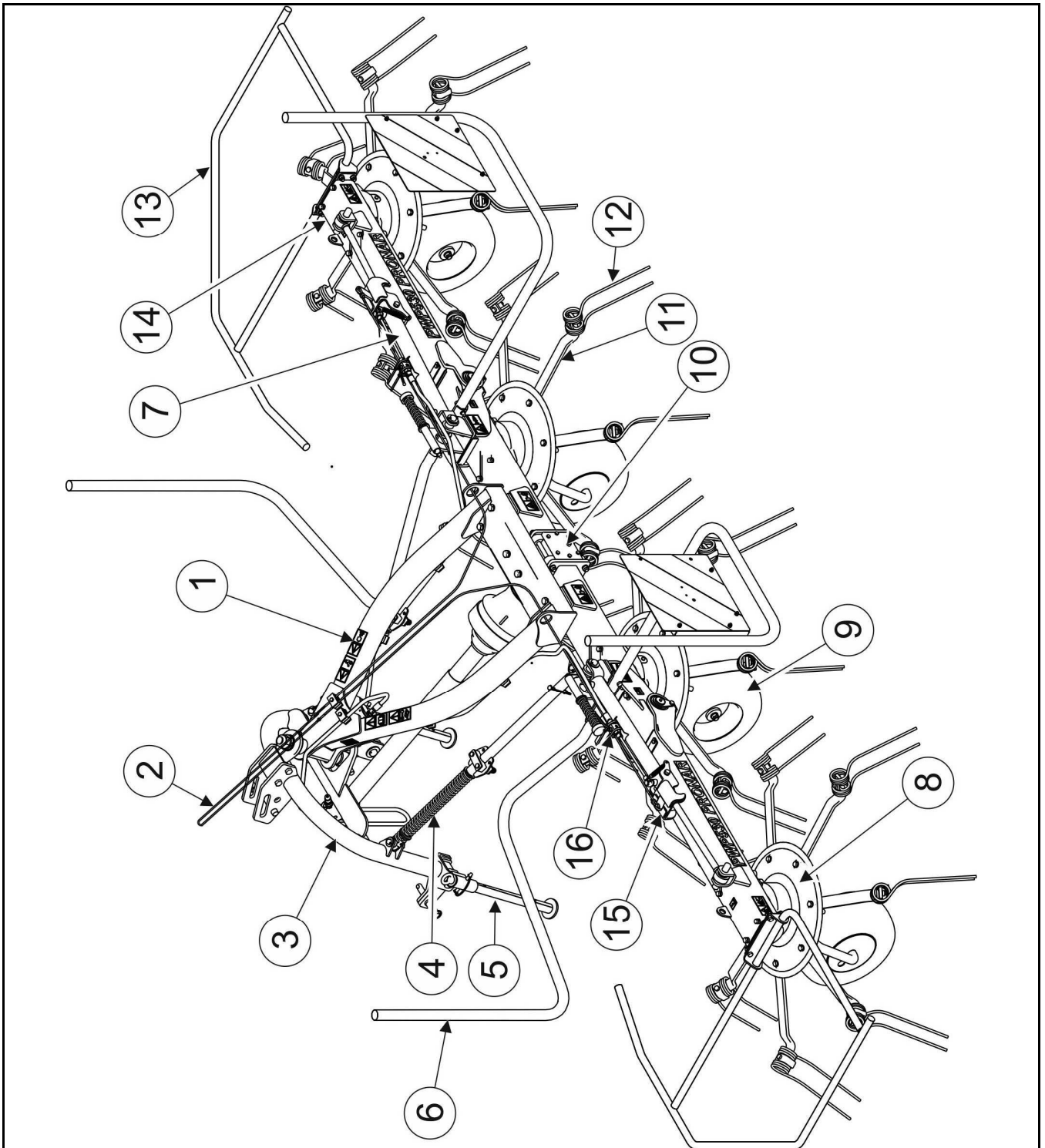

**FIG. 3.1A** Rotary tedder design

(1) bearing frame, (2) releasing cable, (3) hitching system, (4) vibration absorber, (5) support, (6), vertical protection arm (7) hydraulic tipping cylinder, (8) rotor transmission, (9) runner wheel, (10) main transmission, (11) rotor working arm, (12) spring tines, (13) horizontal

*protection arm, (14) bearing frame tipping modules, (15) lock mechanism, (16) tipping cylinder hydraulic locking valve.*

The main transmission is driven by the tractor's PTO shaft. The rotary tedder is equipped with four backward acting rotors seated on running wheels. The two outer rotors are mounted on bearing frame tipping modules that enable optimal machine alignment to uneven surface. They are raised and lowered using hydraulic tipping cylinders and locked in transport position with the aid of a lock mechanism. The lock mechanism is released by pulling the release cable. Hydraulic cylinders are operated with the aid of the tractor's hydraulic system. Each rotor (2) has 7 working arms (3). Each of the arms is equipped with one pair of springtines for tending the swath. They are mounted on the arm extension with the aid of securing elements, which prevent fingers from sliding or rotating.

### **3.3 HITCHING SYSTEM**

The rotary tedder is mounted on the tractor using the hitching system integrated with the support frame of the machine. Figure (3.2A), shows detailed mounting structure.

The rotary tedder is adapted to agricultural tractors equipped with three point linkage category I or II. Pins (1) and (2) – external - serve to attach the machine to a tractor equipped with category II three point linkage, similarly pins (3) and (4) – internal - for linkage to tractor equipped with category I three point linkage. The upper pin is common, designed for securing the upper suspension point irrespective of three point linkage category. The upper pin may be placed in one of the three available sockets.(A), (B) or (C).

The upper mounting frame is secured to the hitching assembly by the aid of a ball and socket joint (10). In the lower part of frame mounting there is a rotating sleeve (11), which moves in a profiled socket. Frame vibrations are absorbed by spring absorbers located on both left and right side of the rotary tedder.

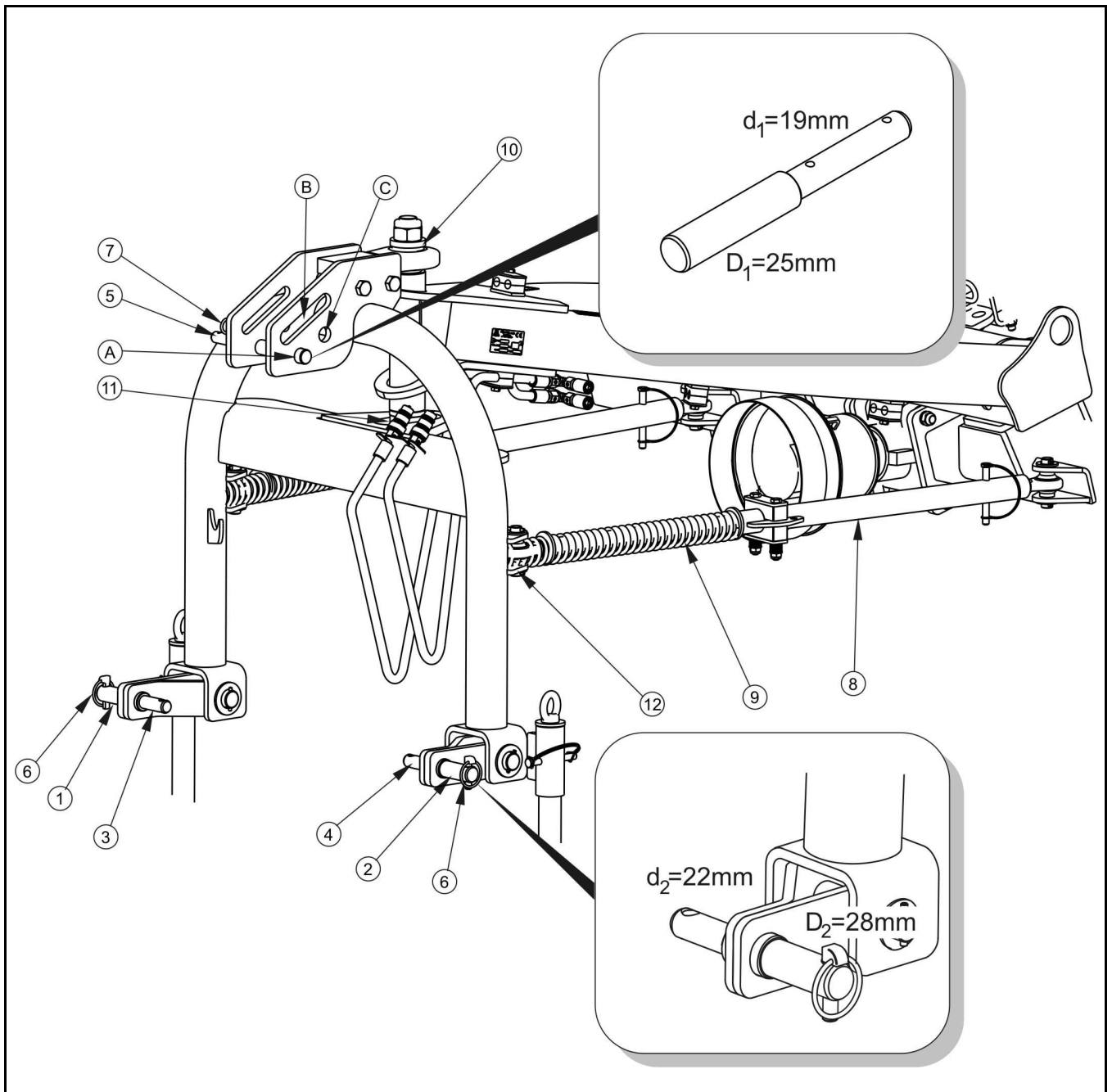
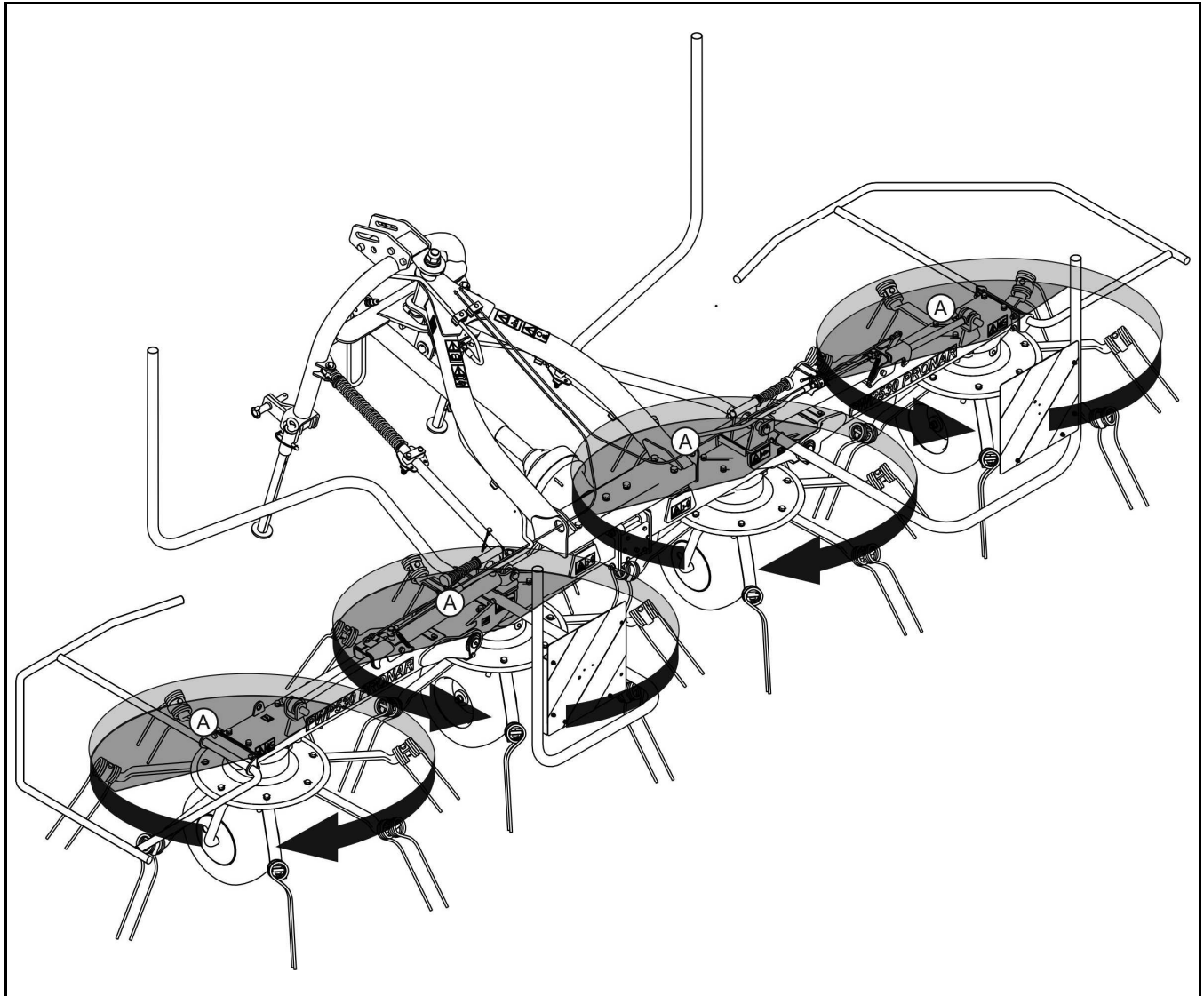

**FIG. 3.2A Hitching system**

(1), (2) lower securing pins (three point linkage – category II), (3), (4) lower securing pins (three point linkage – category I), (5) upper securing pin, (6), (7) locking linchpins, (8) shock absorber bar, (9) absorber spring, (10) ball-and-socket joint, (11) rotator ring, (12) absorber joint, (A), (B), (C) upper pin securing socket.

### 3.4 OPERATING PRINCIPLE

The rotary tedder is equipped with main transmission driven by the tractor PTO shaft. The torque is transferred through transfer shafts placed on the frame to individual tedder rotors placed along bearing frame. The rotor design assures backward rotation of individual rotors, which enables the rotation of neighbouring arms without interference and even spread of the teded material.



**FIG. 3.3A**      **Tedding action principle.**

*(A) swath tedding phase*

**SECTION**

**4**

**CORRECT USE**

PREPARING FOR WORK BEFORE FIRST USE

CHECKING TECHNICAL CONDITION OF TEDDER

ATTACHING TO TRACTOR

PREPARATION OF TEDDER FOR WORK

CONNECTING DRIVESHAFT

TEDDING

DISCONNECTING THE TEDDER

PREPARING TEDDER FOR TRANSPORT

LIGHTING INSTALLATION AND ADDITIONAL MARKING (OPTIONAL)

## 4.1 PREPARING FOR WORK BEFORE FIRST USE

The manufacturer guarantees that the tedder is fully operational and has been checked according to quality control procedures and is ready for normal use. This does not release the user from an obligation to check the machine's condition after delivery and before first use. The machine is delivered to the user in a completely assembled state.

Before connecting to tractor, machine operator must check the technical condition of the tedder and prepare it for test startup. In order to do this:

- the user must familiarise himself with the content of this Operator's Manual and observe all recommendations, understand the design and the principle of machine operation
- check the condition of protective paint coat,
- Inspect tedder's individual components for mechanical damage resulting from incorrect transport (dents, piercing, bent or broken components),
- Check all the tedder's lubrication points, lubricate the machine as needed according to recommendations provided in section 5,
- Check technical condition of tyres and tyre pressure,
- check if wheel and rocker mounting is correct,
- check if mounting of springtines, tedding arms and protective guards is correct,
- check technical condition of hitching system pins and locking linch pins,
- check lubricating oil level in main transmission.

If all the above checks have been performed and there is no doubt as to the tedder's good technical condition, it can be connected to tractor. Start the tractors engine, check all systems and test the tedder before beginning work. In order to inspect:

- hitch tedder to tractor,
- lower right and left module from transport position to working position, level tedding rotors using three point linkage so that spring tines do not touch the ground,
- connect PTO shaft to tractor and tedder

- start PTO drive.

Engage tedder drive for several minutes, and check the following:

- there is no knocking or noise in the drive system arising from scraping or grinding of metal elements,
- correct rotation of tedding system.



### **ATTENTION!**

**Before each use of the tedder check its technical condition. In particular check the technical condition of the tedding system, wheel system, set of safety guards and correct mounting of tedder springtines.**

The tedder's operation at no load should be smooth. Shaking of tedding mechanism and whole machine is not acceptable, nor is changed noise and vibrations coming from loose nut and bolt connections. After stopping tedder check the mounting of tedding springtines and rotor arms. Check that the gear oil does not leak from the main transmission.



### **DANGER**

**Before using the tedder, the user must thoroughly familiarise himself with the content of this operator's manual.**

**Careless and improper use and operation of the tedder, and non-adherence to the recommendations included in this operator's manual are dangerous to health.**

**The tedder must never be used by persons who are not authorised to drive agricultural tractors, including children and people under the influence of alcohol or other drugs.**

**Non-adherence to the principles of safe use creates a danger for the health and life of the operator and others.**



### **DANGER**

**Before starting the tedder, make sure that there are no bystanders in the danger zone.**

If any faults are detected they must be identified and rectified. If a fault cannot be rectified or the repair could void the guarantee, please contact retailer for additional clarifications.

## 4.2 CHECKING TECHNICAL CONDITION OF TEDDER

When preparing the tedder for normal use, check individual elements according to guidelines presented in table (4.1).

**TAB. 4.1 TECHNICAL INSPECTION SCHEDULE**

DESCRIPTION	SERVICE OPERATION	FREQUENCY
Condition of safety guards	check the technical condition of safety guards, if complete and correctly mounted.	Before each use
Correctness of mounting tedding springtines to arms and arms to rotor.	Ensure that springtines are correctly tightened.	
Check technical condition of tyres and tyre pressure,	Visually inspect the tyres and if they are properly inflated.	
Check lubricating oil level in main transmission.	For details please refer to section "MAIN TRANSMISSION SERVICE"	
Check technical condition of tyres and tyre pressure,	Check the condition of tyre tread, lateral surfaces, wheel rim and if necessary inflate the tyres up to recommend pressure	Every month
Check of all main nut and bolt connections are properly tightened	Torque values should be according to table (5.2)	After the winter
Lubrication	Lubricate elements according to guidelines presented in section "lubrication points".	According to table (5.1)



### ATTENTION!

Do NOT use unreliable tedder.



## 4.3 ATTACHING TO TRACTOR

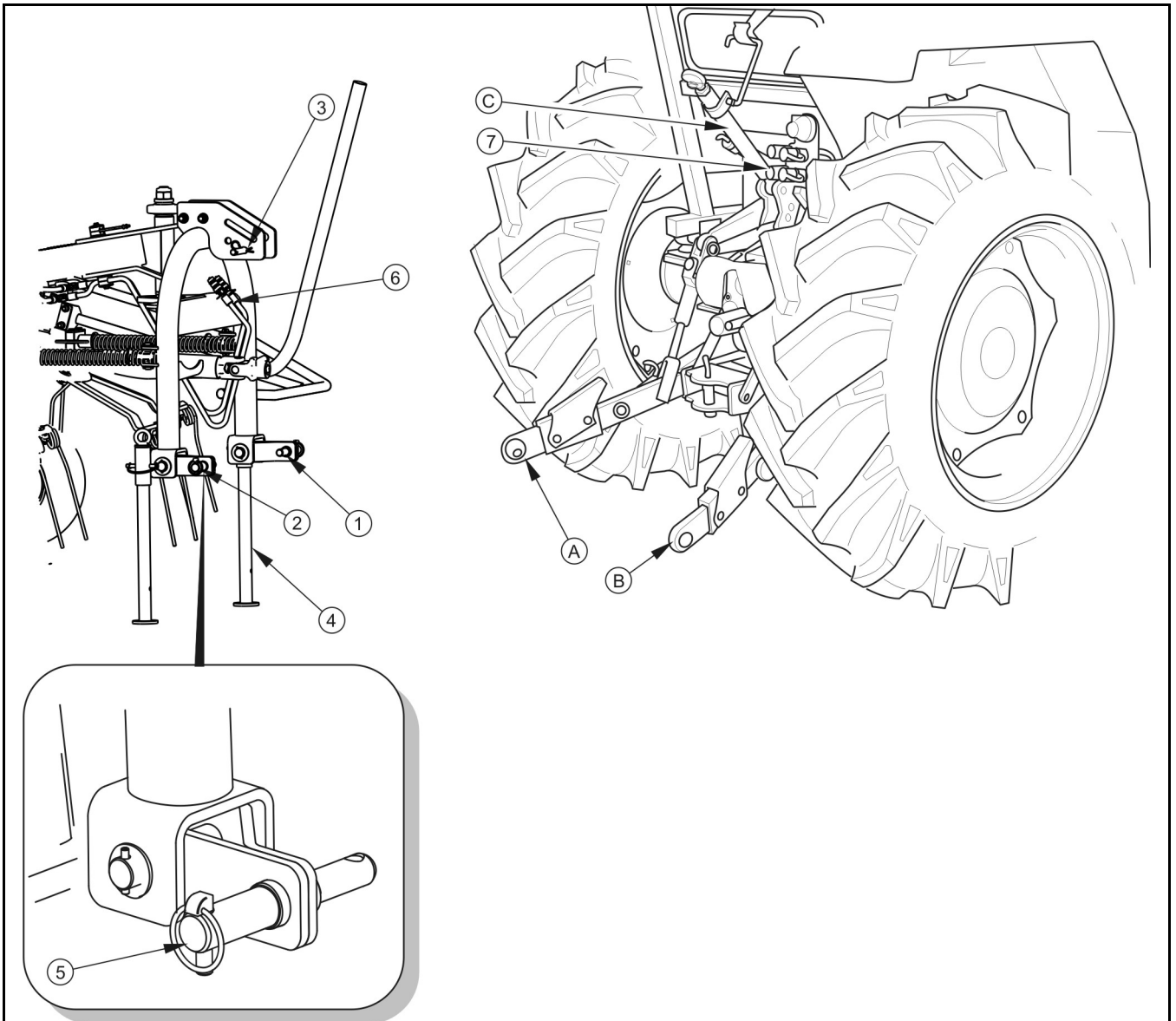

**FIG. 4.1A Attaching tedder to tractor**

(1), (2) lower three point links, (3) upper securing pin, (4) support, (5) locking linchpin, (6) tipping cylinders hydraulic conduits, (7) tractor quickcoupler, (A), (B) three point linkage lower link, (C) three point linkage top link

The tedder may only be connected to tractors with power output greater than 30 hp, equipped with category I or II rear three-point linkage.

- Drive tractor to tedder.
- Reverse tractor ensuring that there is nobody between the tractor and the tedder.

- Reversing the tractor bring the lower three-point linkage connection points (A) and (B) close to pins (1) and (2) of tedder.
- Set connection arms (A) and (B) of tractor at appropriate height.
- Switch off tractor's engine and prevent it from rolling.
- Connect lower pins (1) and (2) with connecting arms (A) and (B) and lock with the aid of linchpins.
- Release top link of tractor and connect it with pin (3) of tedder and lock with linchpin.
- Connect hydraulic conduits (6) of tedder to quickcouplers (7) of tractor double acting hydraulic circuit in FLOATING position.
- Raise the tedder's left and right support (4) and secure with linchpins.

### **ATTENTION!**



Before using the tedder, the user must thoroughly familiarise himself with the tractor operator's manual.

The lower connection arms must at identical height. If not the tedder shall be tilted to the left or right side, which will interfere with the machine's operation. Appropriate adjustment is made with the aid of the tractor lower three-point linkage suspender rods.



### **DANGER**

Exercise caution when linking the machine.



### **DANGER**

Prior to connecting hydraulic system conduits the user must familiarise himself with the content of the tractor operator's manual and observe all recommendations of the manufacturer.



### **DANGER**

When connecting the hydraulic conduits to the tractor, make sure that the hydraulic systems of the tractor is not under pressure.

## 4.4 PREPARATION OF TEDDER FOR WORK

The tedder after transport to the field must be set in correct working position. Preparing of the machine for work must only take place exclusively where the tedder shall work. Do NOT drive on public roads with extended side rotors.

### 4.4.1 SETTING FROM TRANSPORT POSITION TO WORKING POSITION



#### DANGER

Setting from transport position to working position should only be conducted on level and stable surface. Ensure that no one is within reach of tedder rotor arms in the tedder arm tipping area.

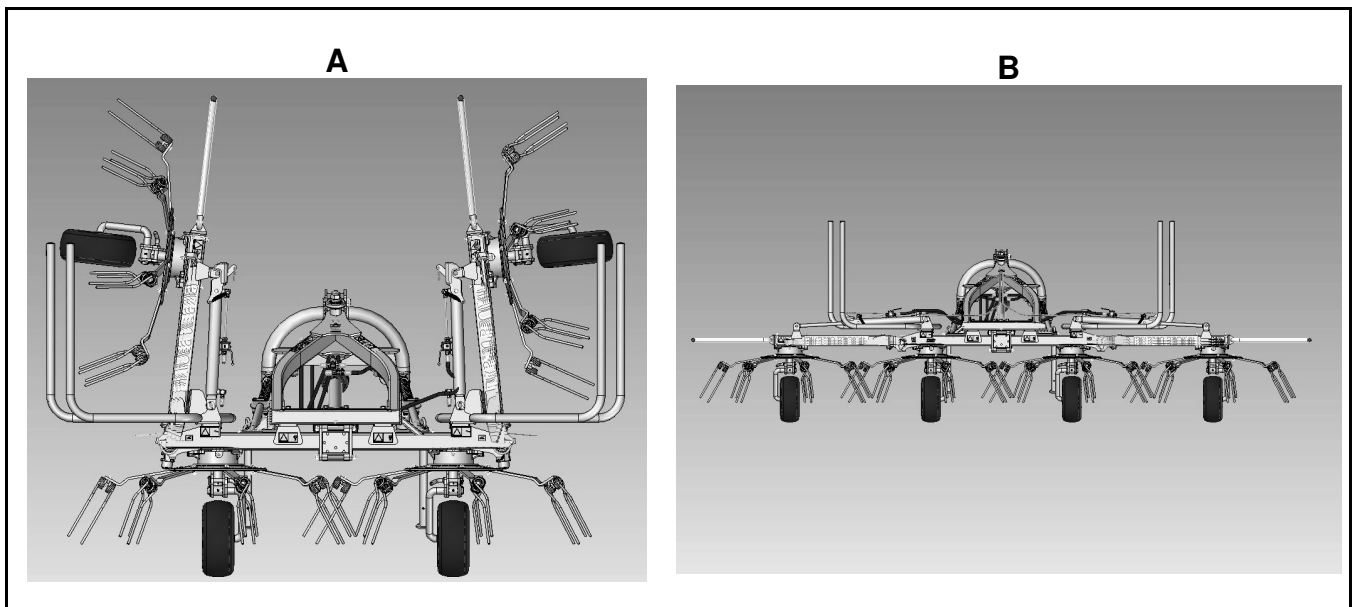
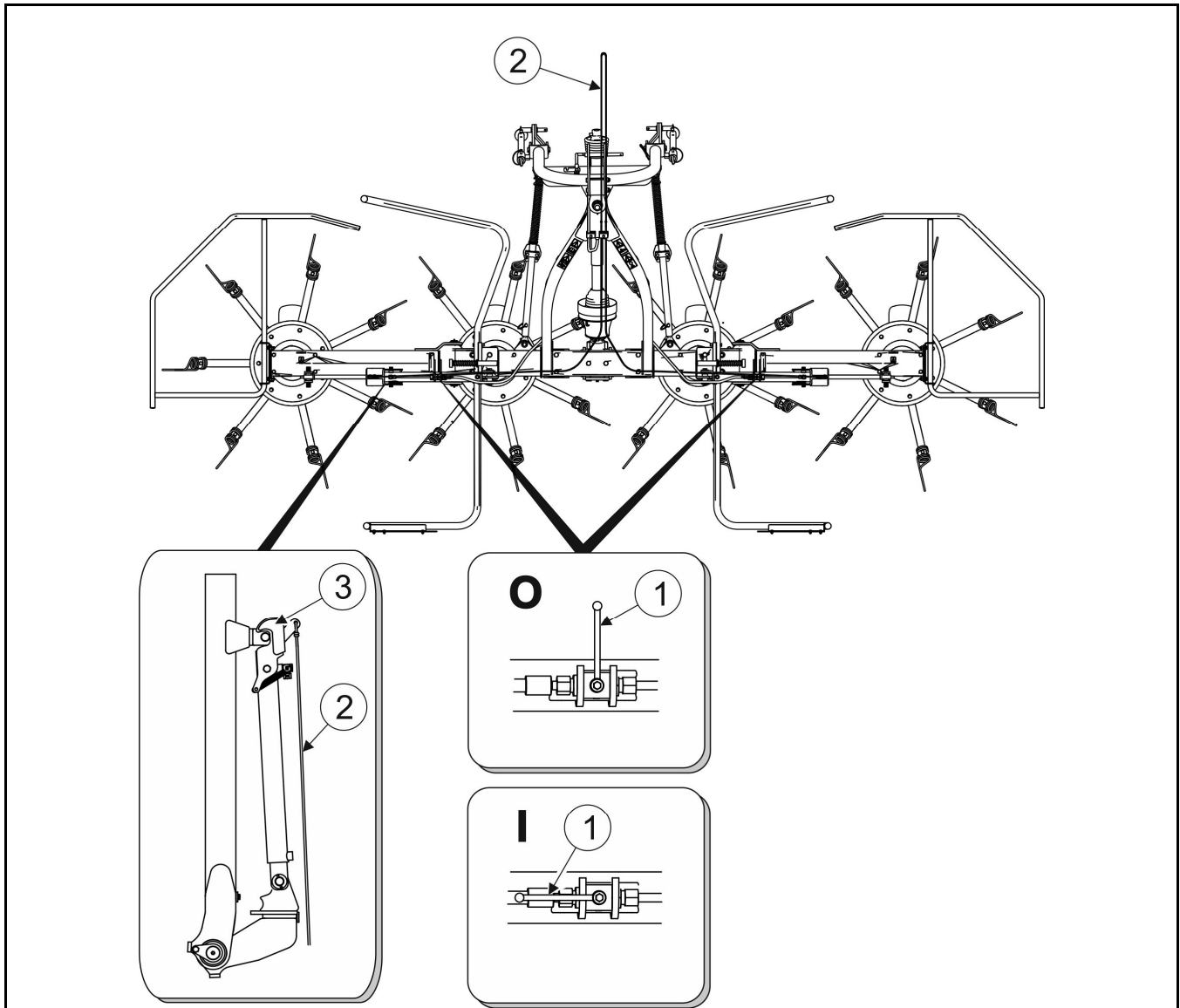

**FIG. 4.2A** Tedder positions

*(A) transport position, (B) working position*

In order to set tedder from transport position (A) to working position (B) perform the following actions:

- Park the tractor and lower tedder onto the support wheels.
- immobilise tractor with parking brake,



**FIG. 4.3A Set tedder in working position.**

*(1) Tipping cylinder valves, (O) CLOSED position, (I) OPEN position*

*(2) cylinders lock release cable, (3) cylinders mechanical lock*

- Set valves (1) of tedder tipping arms cylinders in "OPEN" position.
- Sitting in tractor operator's position briefly set lever of hydraulic manifold in LIFTING position simultaneously pulling and holding the cable (2) releasing the lock mechanism (3) of right and left external rotor hydraulic arm cylinders. After releasing cylinders lock, slowly set tractor hydraulic manifold lever in LOWERING position.

- Lower arms of external rotors until the moment of contact of runner wheels with surface and release cylinder lock cable. Set manifold control lever in FLOATING position allowing external rotors to adjust to unevenness of ground.

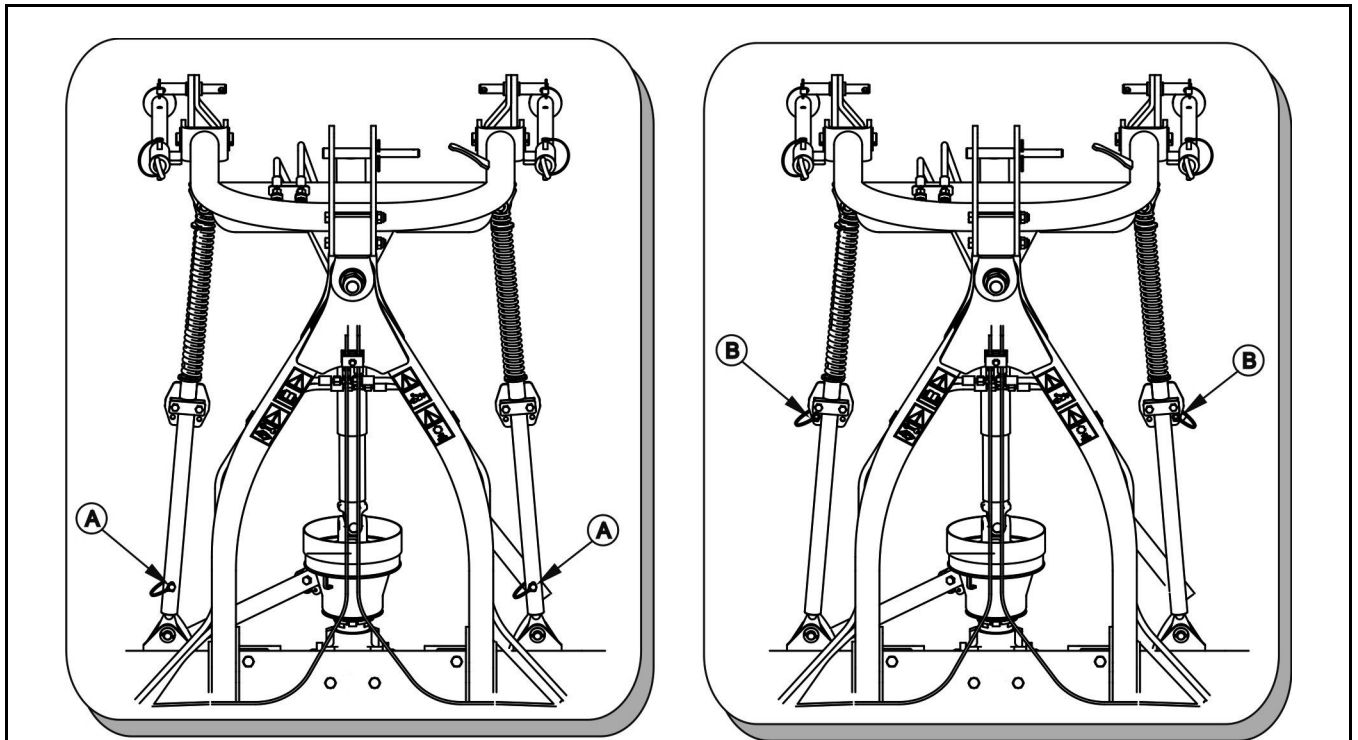

**FIG. 4.4A Set vibration absorber in working position.**

*(A) vibration absorber in locked position, (B) vibration absorber in unlocked position*

- Unlock right and left tedder vibration absorbers taking out locking linchpins (FIGURE 4.4A).

#### **4.4.2 SETTING WORKING POSITION**

The correct working position of the tender has a decisive influence on the quality of the tedding and on working comfort.

One of the basic factors deciding the correctness of machine setting is the correct height adjustment of the lower three-point linkage tractor lift arms. Their height is regulated by the suspender rods. Both the lift arms must be at the same height, if not the tedder may be tilted to the left or the right side. This must be done before connecting tedder to the tractor.



## ATTENTION!

Read the instructions on adjustment of the three-point linkage, which are part of the tractor operator's manual.

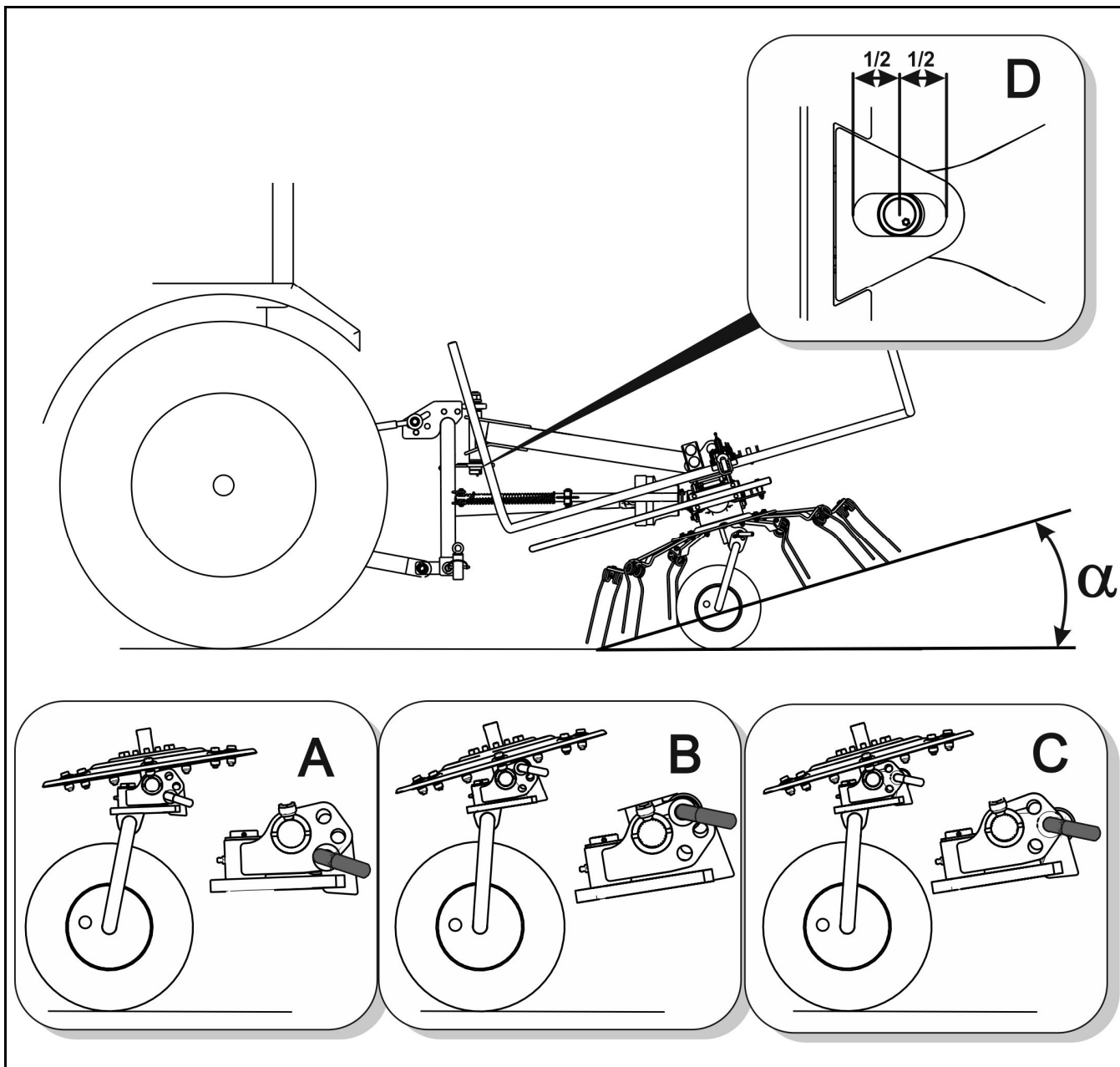

**FIG. 4.5A** Work with tedder – rotor inclination angle (spreading angle)

( $\alpha$ ) spreading angle, (A) large spreading angle, (B) small spreading angle, (C) normal spreading angle, (D) sleeve setting in openings

Adjustment of working position is performed after lowering the machine to the ground. Working position of tedder is regulated by performing the following actions:

- park tractor and tedder on flat level ground,
- set rear three point linkage in position adjustment mode,
- set height of lower forks of tractor three point linkage and adjust top link in such a way, the rotors are inclined forward and springtines lightly touch the ground, and angles sleeves are in the central part of the extended opening D (FIGURE 4.5A),

After adjusting tractor rear three point linkage set the swath spreading angle (FIGURE 4.5A).

In order to do this:

- park tractor and tedder on flat level ground,
- raise tedder by the minimal height enabling tilting of support wheels,
- support machine to prevent it falling,
- insert pins locking wheels' position at required angle of inclination and secure them with linchpins,
- lower machine onto support wheels.

Springtines should lightly touch the ground. Selection of height and inclination angle of rotors depends on the volume of the cut swath, swath moisture, speed of tedding and condition of field surface. If springtines are too high from the ground there is a risk that not all of the swath will be teded. At a low setting the swath may be contaminated with disturbed earth, turf and stones etc. Furthermore there is increased danger of damage to the tedder, mainly to springtines and their mounting to the arms. Height selection should be checked frequently during tedding and if necessary the setting should be corrected

If the height setting of the tedder sprintines is incorrect, adjust the height setting of lower three point linkage forks, length of the link and readjust the height setting of the tedding assembly.



### **DANGER**

**Adjustment of tedder's working height and swath spreading angle must be done with the tractor engine switched off. Remove the key from the ignition, ensure that unauthorised persons do not have access to the tractor. Tractor shall be immobilised with parking brake.**

## 4.5 CONNECTING DRIVESHAFT

The tedder is equipped with the appropriately selected PTO shaft with overload clutch. Before connecting the tedder it is absolutely necessary to acquaint oneself with the content of the Operator's Manual attached by the manufacturer of the shaft and observe the instructions contained in it. Before connection to the tractor check the technical condition of the shaft guard, the completeness and condition of the protecting chains and the general technical condition of the shaft. Multisplined ends are appropriately marked, so it is clear which end should be connected to the tractor.

Shaft is equipped with overload protection clutch, which prevents damage to tedder or tractor. Torque value for shaft is set in the factory by the manufacturer and may not be changed by the user. Change of overload protection clutch setting may invalidate the guarantee

### **DANGER**



**Before connecting the shaft, turn off the tractor's engine and remove the key from the ignition. Ensure that unauthorised persons do not have access to the tractor.**

**The use of PTO shaft and its technical condition must be in accord with the Operator's Manual of PTO shaft.**

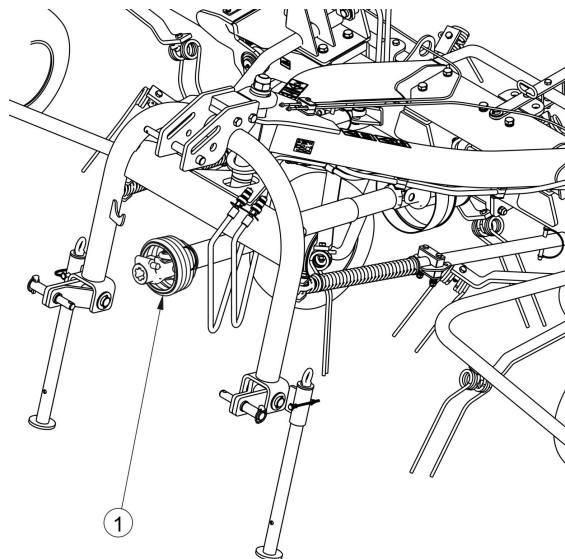

**FIG. 4.6A PTO shaft with overload protection clutch**

*(1) PTO shaft*



## 4.6 TEDDING

If the tedder is properly prepared for work in the field, is completely reliable and its technical condition causes no reservations, work in the field may commence. Recommended working speed is 10 km/h or less. At greater travelling speeds the swath may not be completely and properly tilled. Allowable revolution speed of PTO shaft is 540 rpm however recommended speed is about 500 rpm. With a very dry swath it is recommended that PTO shaft speed should be reduced even further.



### **IMPORTANT!**

**Do NOT start tedder with PTO revs speed higher than 540 revs/min.**

The revolution speed of the shaft and the speed of travel depend on several factors, including size of swath, degree of moisture, length of swath, type of ground, therefore the selection of appropriate working parameters rests on the person operating the tedder. During machine operation the linkage system shall be set in operating mode adjusting position, and tilling rotors modules' tipping cylinders set in FLOATING position.



### **DANGER**

**Before engaging drive to PTO shaft make sure that there are no bystanders, especially children, near the tedder. Maintain proper visibility of machine during work**

**Other persons should stay at a safe distance (minimum 50 metres) from tedder during work because of the danger of objects (stones, branches) thrown from under tilling springtines.**

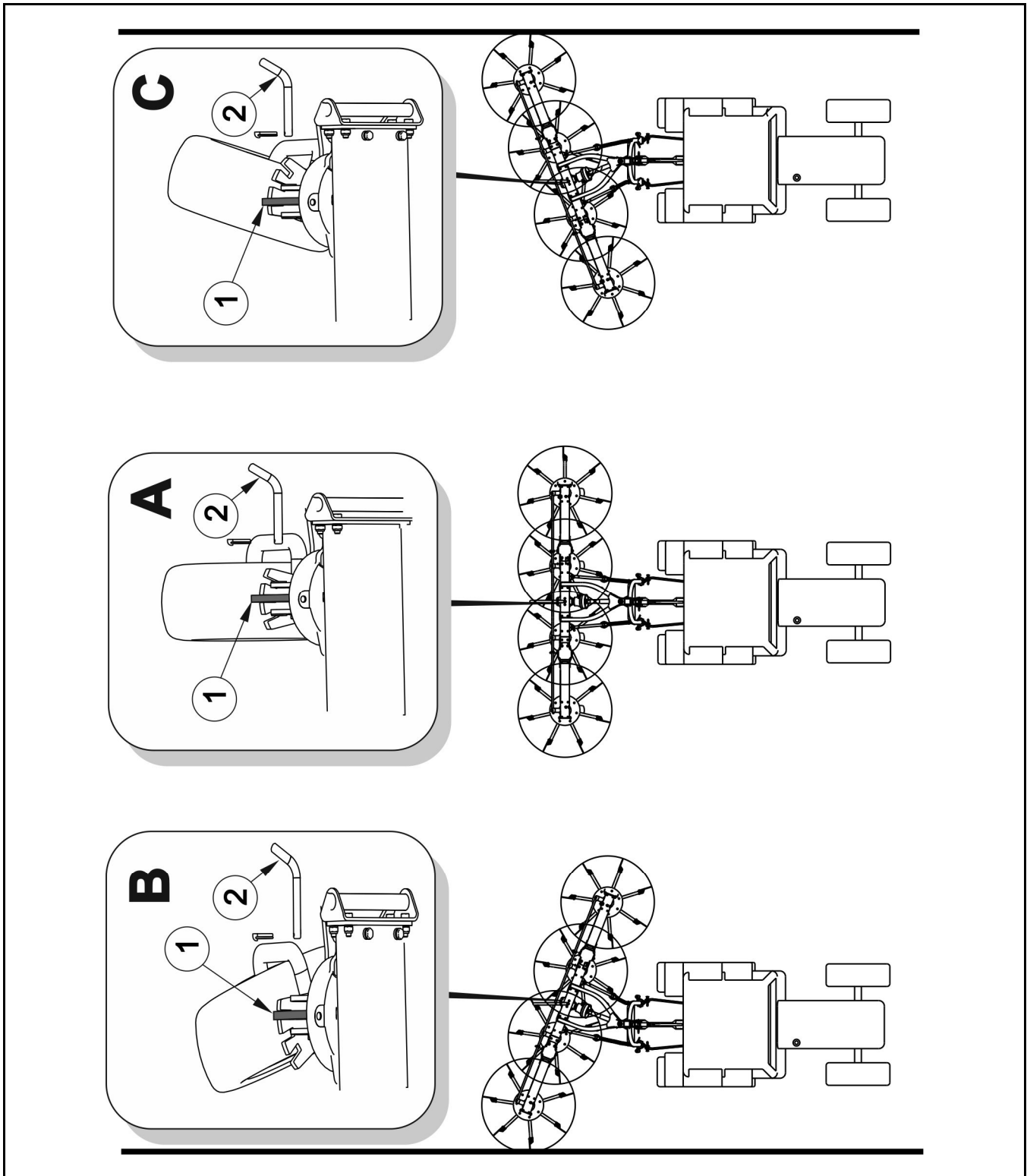

**FIG. 4.7A Work with tedder – tedding along the field edge**

*(1) wheel tilt lock mechanism (2) locking pin*

*(A) tedding to the centre, (B) tedding right side edge, (C) tedding left side edge*

During tedding along field edge support wheels swivel inclination is set. In the event of work tedding along the right side field edge set swivel wheels to the right (B), in the event of work tedding along the left side field edge set swivel wheels to the left side (C). Leave a setting is performed after previously raising machine to minimal height enabling removal of wheels locking pin and setting in the desired position.

During turning or reversing, PTO shaft should be disengaged and tedder raised.

## **4.7 DISCONNECTING THE TEDDER**

In order to disconnect the tedder from the tractor perform the following:

- lower the tedder's left and right support and secure with linchpins.
- lower tedder using three-point linkage to rest position,
- switch of tractor engine and remove key from ignition,
- disconnect PTO shaft,
- disconnect hydraulic conduits from tractor quickcouplers,
- disconnect top link of three-point linkage,
- disconnect lower pins of the tedder and drive tractor away.

## **4.8 PREPARATION OF TEDDER FOR TRANSPORT**

After completion of work in the field the tedder must be folded in transport position. Before beginning preparatory work brake tractor with parking brake and secure tractor, ensure that unauthorised persons do not have access to the tractor.

Do NOT travel with side rotors in work position. During travel they must be raised upwards and locked with the aid of cylinder lock mechanisms and also by closed tipping cylinder valves.

To prepare tedder for transport (see FIGURE 4.3A, 4.4A):

- Raise side rotor arms using hydraulic system to the moment that cylinder lock mechanisms are engaged
- Set tipping cylinder valves in CLOSED setting
- Lock vibration shock absorbers

Disconnection of PTO shaft is not essential but it is recommended. Turning sharp corners, especially in field conditions may be hindered because of this. If the shaft is not taken off, is essential to remember not to engage the PTO drive of the tractor during transport travel.

During transport the tedder must be raised by the three-point linkage.

## **DANGER**



**Preparing the tedder for transport may only be done with tractor engine switched off. Remove the key from the ignition, ensure that unauthorised persons do not have access to the tractor. Tractor shall be immobilised with parking brake.**

**Do NOT drive on public roads when visibility is limited.**

## **DANGER**



**During preparation of tedder for transport check that lock mechanisms of tipping cylinders are properly engaged and that the hydraulic valves of these cylinders are in CLOSED setting.**

# 4.9 LIGHTING INSTALLATION AND ADDITIONAL MARKING (OPTIONAL)

## 4.9.1 CONSTRUCTION

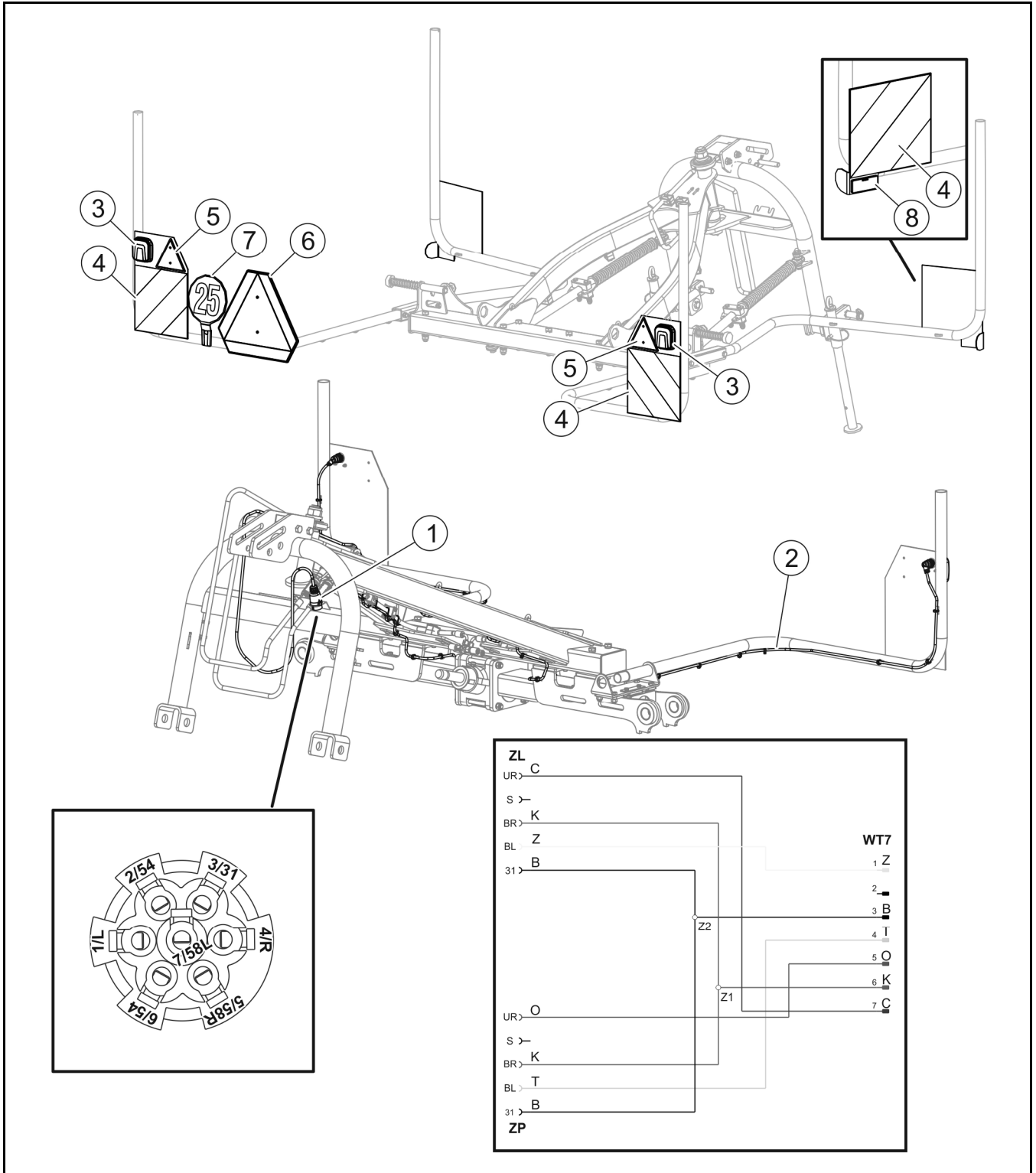

FIG. 4.8A Lighting installation and additional marking.

1) 7-pin electric plug, (2) central harness, (3) combination rear lamps, (4) contour marking, (5) reflective triangle DOB-31 (option), (6) TW-11 slow-moving vehicle sign (option), (7) 25 km/h sticker (option), (8) DOB-35 white rectangular reflector (option)

**TAB. 4.2 MARKINGS OF CONNECTION SOCKET**

<b>MARKING</b>	<b>FUNCTION</b>
3/31	Weight
2/54	Not used
1/L	Left direction indicator
6/54	STOP light
7/58L	Rear left position light
5/58R	Rear right position light
4/R	Right direction indicator

**TAB. 4.3 COLOUR CODING OF WIRES**

<b>MARKING</b>	<b>FUNCTION</b>
b	White
c	Black
f	Purple
k	Red
l	Azurite
n	Blue
o	Brown
p	Orange
r	Pink
s	Grey
t	Green
z	Yellow

**TAB. 4.4 ELECTRICAL ELEMENTS MARKINGS**

<b>MARKING</b>	<b>FUNCTION</b>
WT7	7-pin plug
ZP	Multifunctional rear right lamp
ZL	Multifunctional rear left lamp

## 4.9.2 USAGE AND MAINTENANCE

The power supply to the lighting system of the machine requires the electrical installation of a tractor with a voltage of 12V with a 7-pin electrical outlet.



### CAUTION

Driving with defective lighting installations is prohibited. Damaged lamps should be replaced immediately before driving off. Lost or damaged reflectors should be replaced with new ones.

Before travelling, make sure that all lamps and reflectors are clean.

Works related to the repair, replacement or regeneration of electrical installation components should be entrusted to specialized workshops that have appropriate technologies and qualifications to perform this type of work.

Your duties include only technical inspection of the electrical installation and reflectors.

### The scope of service activities

1. Connect the lighting system of the machine to the tractor with a suitable electrical outlet.



### CAUTION

If the tractor does not have the correct sockets or if the sockets are of a different type, have them installed by qualified personnel.

2. Check the completeness, technical condition and correct functioning of the machine lighting.
3. Check the tractor connection socket and the cable plug on the machine.



### CAUTION

A damaged body of the socket or plug of the electric cord qualifies for replacement.

4. Check the the wiring harness for damage (rubbed insulation, wire break, etc.).
5. Check the mounting of the SMV triangular plate and its bracket.

Before travelling on a public road, make sure that the tractor has a reflective warning triangle.





**SECTION**

# **5**

# **TECHNICAL MAINTENANCE**

SAFE MAINTENANCE PRINCIPLES

OPERATION OF MAIN TRANSMISSION

HYDRAULIC SYSTEM OPERATION

STORAGE

LUBRICATION

CHECKING AND REPLACEMENT OF SPRINGTINES

TIGHTENING TORQUE FOR NUT AND BOLT CONNECTIONS

## **5.1 SAFE MAINTENANCE PRINCIPLES**

- Repair, maintenance and cleaning work should be carried out with the tractor's engine switched off and the ignition key removed. Ensure that unauthorised persons, especially children, do not have access to the tractor.
- The machine must not be used when not in working order.
- Repair work on the wheels or tyres should be carried out by persons trained and entitled to do so. This work should be carried out using appropriately selected tools.
- In the event of work requiring the tedder to be raised, use properly certified hydraulic or mechanical lifts for this purpose. After lifting the machine, stable and durable supports must also be used. Work must not be carried out under a machine which has only been raised with a lift jack.
- The machine must not be supported using fragile elements (bricks or concrete blocks).
- When operating the machine wear protective gloves and use the appropriate tools.
- Servicing and repair work should be carried out in line with the general principles of workplace health and safety. In the event of injury, the wound must be immediately cleaned and disinfected. In the event of more serious injuries, seek a doctor's advice.

## **5.2 OPERATION OF MAIN TRANSMISSION**

Service of main transmission is conducted during general inspection, change or topping up gear oil. In the event of damage to transmission contact authorised service point in order perform repairs.

First oil change must be made after the first 50 hours worked. The next oil change should be made after 500 hours of tedder work or once a year. Most suitable time for changing gear oil is when preparing for first fieldwork. The quantity of oil necessary to fill the reduction gear box amounts to 1.2 litres. Transmission oil required: SAE90EP.

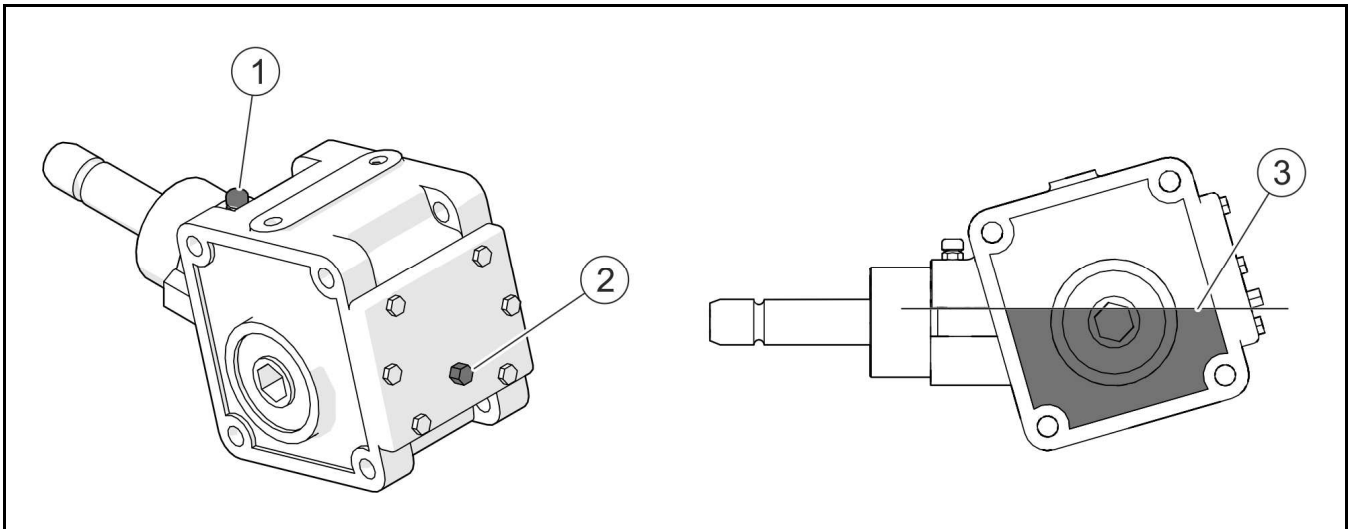

**FIG. 5.1A Changing gear oil**

*(1) inlet plug, (2) overflow-drain plug, (3) correct oil level*

To change oil in main transmission:

- set tedder on a hard surface and tilt machine maximally backwards,
- unscrew inlet plug (1),
- unscrew overflow-drain plug (2), on the rear part of the reduction gear,
- drain oil into oil resistant tight container, container capacity should be about 3litres,
- if oil manufacturer recommends flushing transmission system, that operation should be performed according to the guidelines of the oil manufacturer (such instructions may be described in detail in oil container),
- level the machine
- add oil until oil flows out through opening (2),
- tighten overflow-drain plug (2),
- tighten inlet plug (1).



**The first oil change should be made after 50 hours of tedder work and the next change should be after 500 hours or once a year.**

If a leak is noticed, carefully inspect seals and check oil level. Transmission operation with insufficient oil may cause permanent damage of the mechanism.

Repair of transmission during guarantee period may only be performed at authorised mechanical workshops.

## 5.3 OPERATION OF HYDRAULIC SYSTEM



### **DANGER**

Before commencing whatever work on hydraulic system reduce the pressure in the system.



### **DANGER**

During work on hydraulic systems use the appropriate personal protection equipment i.e. protective clothing, footwear, gloves and eye protection. Avoid contact of skin with oil.

Always adhere to the principle that the oil in the tedder hydraulic system and in the tractor hydraulic system are the same type. Application of different types of oil is not permitted. The hydraulic system in a new tedder is filled with AGROL U hydraulic oil.



### **ATTENTION!**

The condition of hydraulic system should be inspected regularly while using the machine.

The hydraulic system should be completely tight sealed. Inspect the seals when hydraulic ram cylinders are completely extended. In the event of confirmation of oil on hydraulic ram cylinder bodies ascertain origin of leak. Minimum leaks are permissible with symptoms of "sweating", however in the event of noticing leaks in the form of "droplets" stop using the machine until the fault is remedied.

In the event of confirmation of an oil leak on hydraulic conduit connections, tighten connections, and if this does not remedy faults then change conduit or connection elements. Change of sub assemblies is equally required in each instance of mechanical damage.

The oil applied because of its composition is not classified as a dangerous substance, however long-term action on the skin or eyes may cause irritation. In the event of contact of oil with skin wash the place of contact with water and soap. Do not apply organic solvents (petrol, kerosene). Contaminated clothing should be changed to prevent access of oil to skin. In the event of contact of oil with eye, rinse with large quantity of water and in the event of the occurrence of irritation consult a doctor. Hydraulic oil in normal conditions is not harmful to the respiratory tract. A hazard only occurs when oil is strongly atomised (oil vapour), or in the case of fire during which toxic compounds may be released. Oil fires should be quenched with the use of carbon dioxide (CO<sub>2</sub>), foam or extinguisher steam. Do NOT use water for fire extinguishing.

Spilt oil should be immediately collected and placed in marked tight container. Hydraulic oil should be taken to the appropriate facility dealing with the re-use of this type of waste.



**Flexible hydraulic conduits should be replaced after 4 years of use.**

**TAB. 5.1 CHARACTERISTICS OF AGROL U OIL**

ITEM	NAME	UNIT	VALUE
1	Kinematic viscosity at 100°C	-	10.0- 11.5
2	Viscosity index, min.		>95
3	Pour point, max.	°C	<-24
4	Base number mgKOH/g	-	9.9
5	Flash-point	°C	>230

## 5.4 STORAGE

After completing work the tedder should be carefully cleaned and washed with water jet. While washing do not direct a strong water or steam jet at information and warning stickers or bearings. Nozzle of pressure or steam washer should be kept at a distance of not less than 30 cm from cleaned surface.

After cleaning tedder inspect the whole machine, inspect technical condition of individual elements. Used or damaged elements should be repaired or replaced.

In the event of damage to the paint coat, clean rust and dust from damaged area, degrease and then paint with undercoat and after it is dry paint with surface coat paint retaining colour uniformity and even thickness of protective coating. Until the time of touch-up painting, the damaged place may be covered with a thin layer of grease or anticorrosion preparation. Tedder should be kept in closed or roofed building.



### **DANGER**

**Tedder should only be stored with extended side rotors (to prevent danger of tipping over)**

If the tedder will not be used for a long time, it is essential to protect it from adverse weather, especially rust and accelerated tyre deterioration. Cylinder pistons should be cleaned and conserved with grease.

Lubricate tedder according to the instructions provided. In the event of prolonged work stoppage, it is essential to lubricate all elements regardless of the period of the last lubrication process. Additionally before the winter period hitching system pins should be smeared with grease.

Tyres should undergo conservation maintenance at least twice a year using the appropriate preparations designed for this purpose. Complete wheels and tyres should be previously carefully washed and dried. During longer storage of unused tedder it is recommended that every 2 to 3 weeks the machine may be moved a bit so that the place of contact of tyres with ground is changed. So that tyres are not deformed and maintain proper geometry. Also tyre pressure should be inspected from time to time, and if necessary pressure should be increased to appropriate value.

## 5.5 LUBRICATION

Tedder lubrication shall be performed where indicated on figure (5.2A) as stipulated in table (5.2). This procedure should be performed using a hand or foot operated grease gun filled with generally available permanent grease. Before commencing lubrication in so far as is possible remove old grease and other contamination. Remove excess oil or grease

Oil in main gear shall be changed after the first 50 hours, and then after 500 hours or once a year of use. Detailed description of oil change and service of reduction gear is given in section 5.1 "Service of main gear"



**When using the tedder the user is obliged to observe lubrication instructions according to attached schedule. Excess greasing substance causes depositing additional contaminants in places requiring greasing, therefore it is essential to keep individual machine elements clean.**

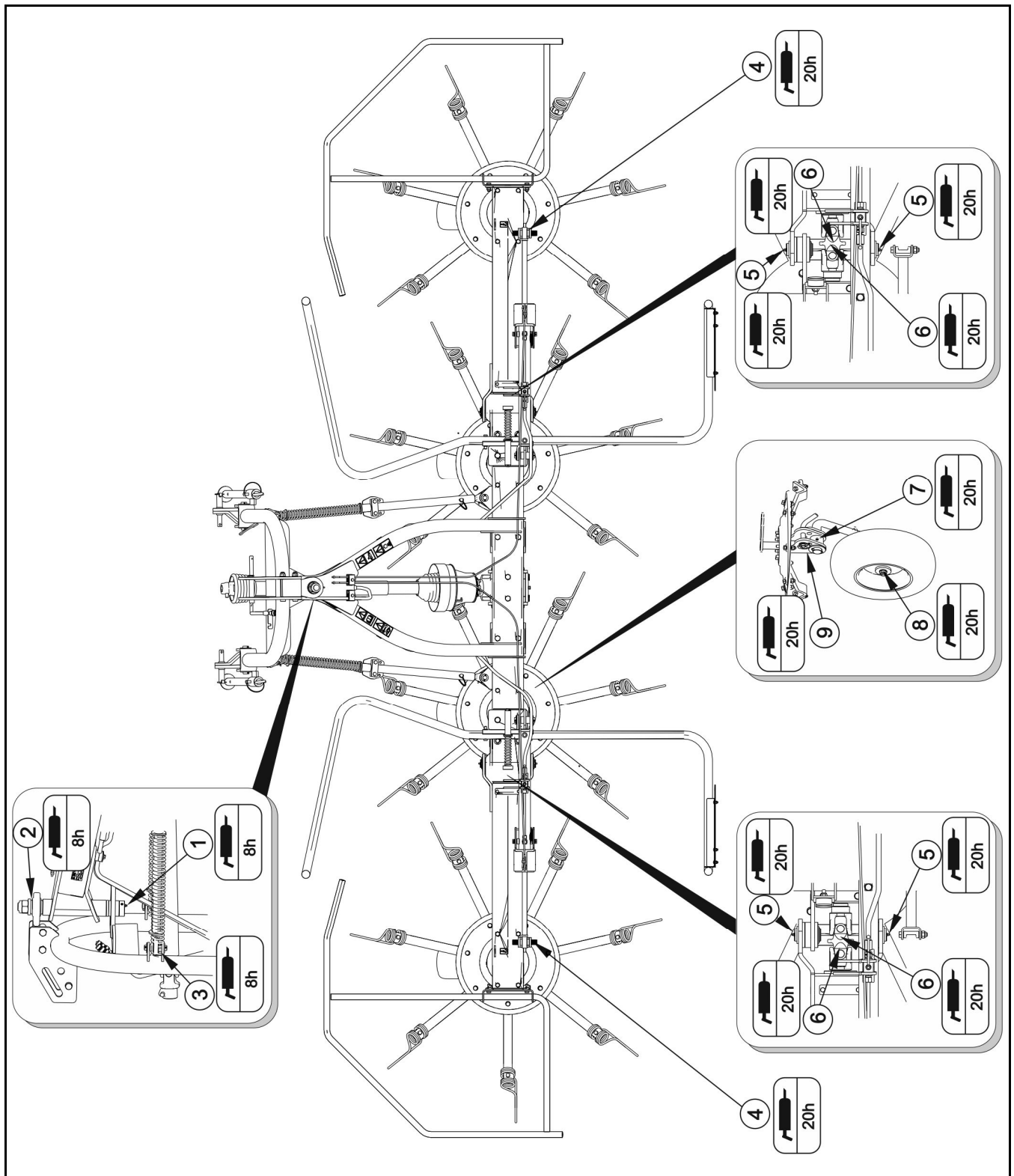

**FIG. 5.2A**      **Tedder lubrication points**



**TAB. 5.2 LUBRICATION POINTS**

ITEM	NAME	NUMBER OF LUBRICATI ON POINTS	TYPE OF GREASE	GREASING FREQUENCY
1	Turntable ring	1	PERMANENT	8 hours
2	Frame suspension ball-and-socket joint	1	OIL	8 hours
3	Vibration absorber ball-and-socket joint	2	OIL	8 hours
4	Tilting arm cylinder ram eye	2	PERMANENT	20 hours
5	Tipping arm rotation axis	4	PERMANENT	20 hours
6	Articulations of rotors' drive shaft	4	PERMANENT	20 hours
7	Runner wheel bracket axis	4	PERMANENT	20 hours
8	Runner wheel rotation axle	4	PERMANENT	20 hours
9	Runner wheel bracket axis	4	PERMANENT	20 hours
	Articulated telescopic shaft★			

*IMPORTANT! Marking description in Item column in table (5.2) conforms with numbering shown in figure (5.2A).*

★ Articulated telescopic shaft lubrication should be performed according to the instructions of manufacturer. Detailed information on maintenance is contained in maintenance instructions attached to the shaft.

## 5.6 CHECKING AND REPLACEMENT OF SPRINGTINES



### **DANGER**

**Before beginning preparation work switch off tractor engine and remove the key from the ignition and engage tractor parking brake. Ensure that unauthorised persons do not have access to the tractor.**

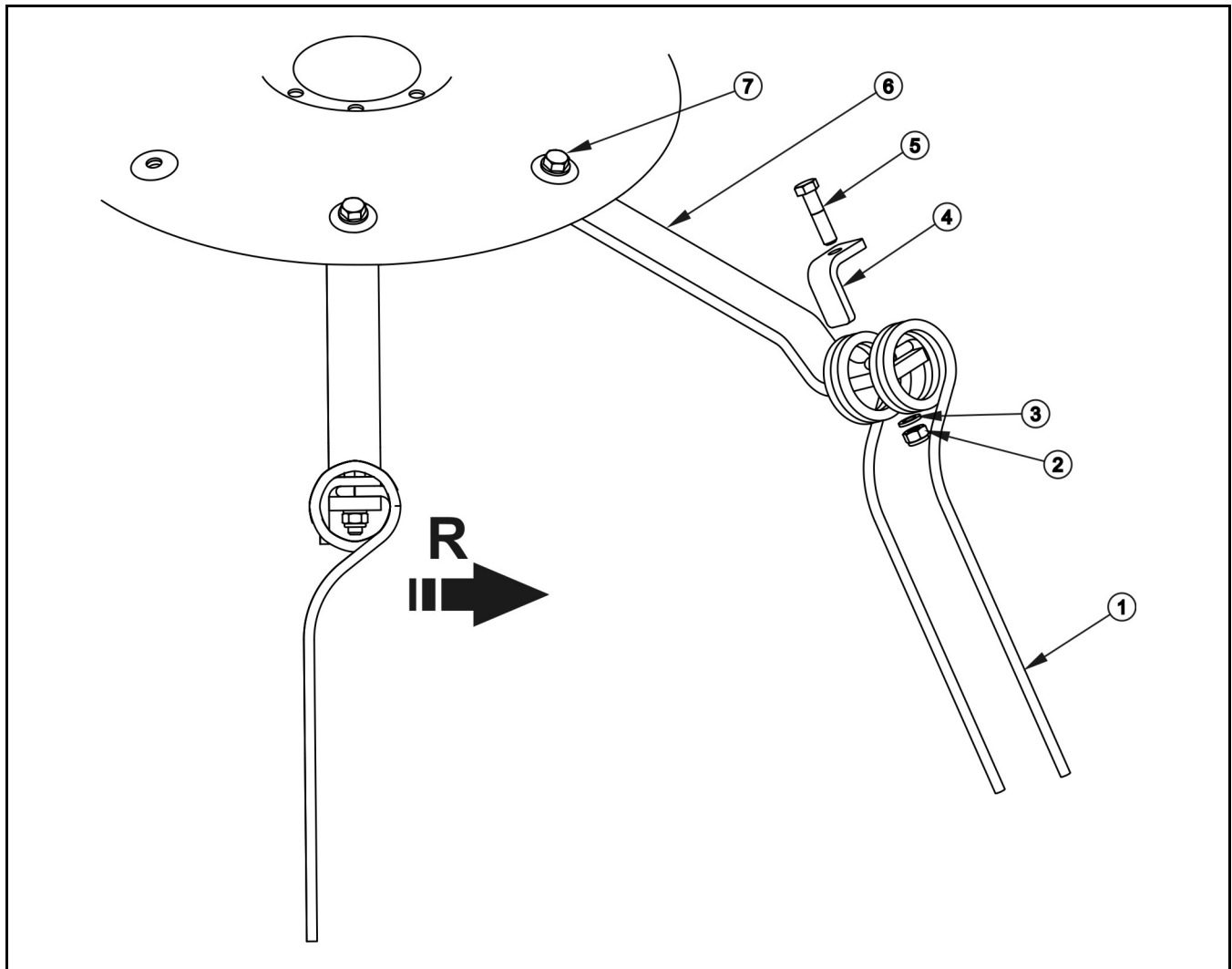

**FIG. 5.3A**      **Changing springtines**

(1) springtine, (2) self locking nut, (3) washer, (4) mounting element, (5) bolt securing springtime to arm, (6) rotor arm, (7) bolts securing arm to rotor, (R) rotor rotation direction.

In order to dismantle springtines:

- unscrew nut (2)
- dismantle securing element (4) and bolt (5)
- remove damaged springtine (1) from arm (6) and mount new springtine,
- insert bolt (5) and mounting element (4) and tighten nut with appropriate torque



## ATTENTION!

When mounting springtines check the rotation direction (R) of rotor.

Springtines and their mounting should be checked while working with tedder. Damaged elements should be replaced. It is not possible to repair springtines.



Each day check condition of springtine connections to arms and connections of arms to rotors.

## 5.7 TIGHTENING TORQUE FOR NUT AND BOLT CONNECTIONS

Unless other tightening parameters are given, during maintenance repair work apply appropriate torque to tightening nut and bolt connections. Recommended tightening torque of most frequently applied nut and bolt connections are given in table (5.3). Given values apply to non greased steel bolts.

Detailed inspection of tightness of nut and bolt connections should be made after the first 10 hours of work, and then each time at the end of working year of tedder.

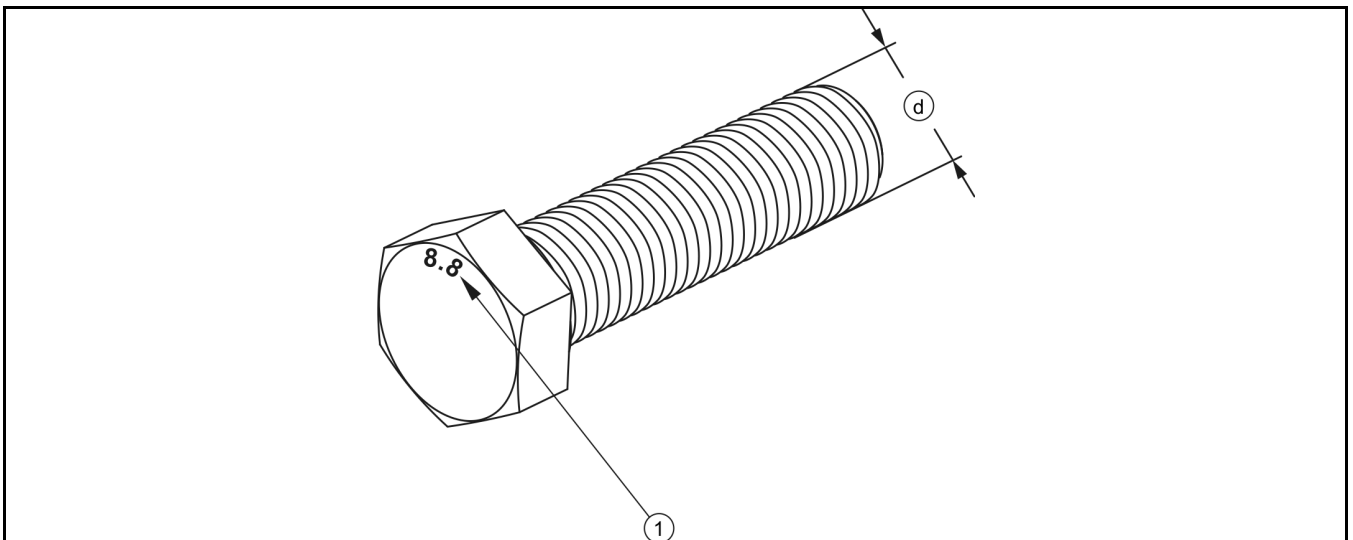

**FIG. 5.4A Bolt with metric thread**

*(1) bolt strength class, (d) thread diameter*

**TAB. 5.3 TIGHTENING TORQUE FOR NUT AND BOLT CONNECTIONS**

THREAD (d) [mm]	5.8	8.8	10.9
	$M_D$ [Nm]		
M6	8	10	15
M8	18	25	36
M10	37	49	72
M12	64	85	125
M14	100	135	200
M16	160	210	310
M20	300	425	610
M24	530	730	1050
M27	820	1 150	1 650
M30	1 050	1 450	2 100

*( $M_D$ ) – tightening torque, (d) thread diameter*

# NOTES

A series of horizontal dotted lines for writing notes.



