



PRONAR Sp. z o.o.

17-210 NAREW, UL. MICKIEWICZA 101A, PODLASKIE PROVINCE

phone:	+48 085 681 63 29	+48 085 681 64 29
	+48 085 681 63 81	+48 085 681 63 82
fax:	+48 085 681 63 83	+48 085 682 71 10

www.pronar.pl

OPERATOR'S MANUAL

TRAILED SWEEPER

PRONAR ZMC3.0

TRANSLATION OF THE ORIGINAL COPY OF THE MANUAL

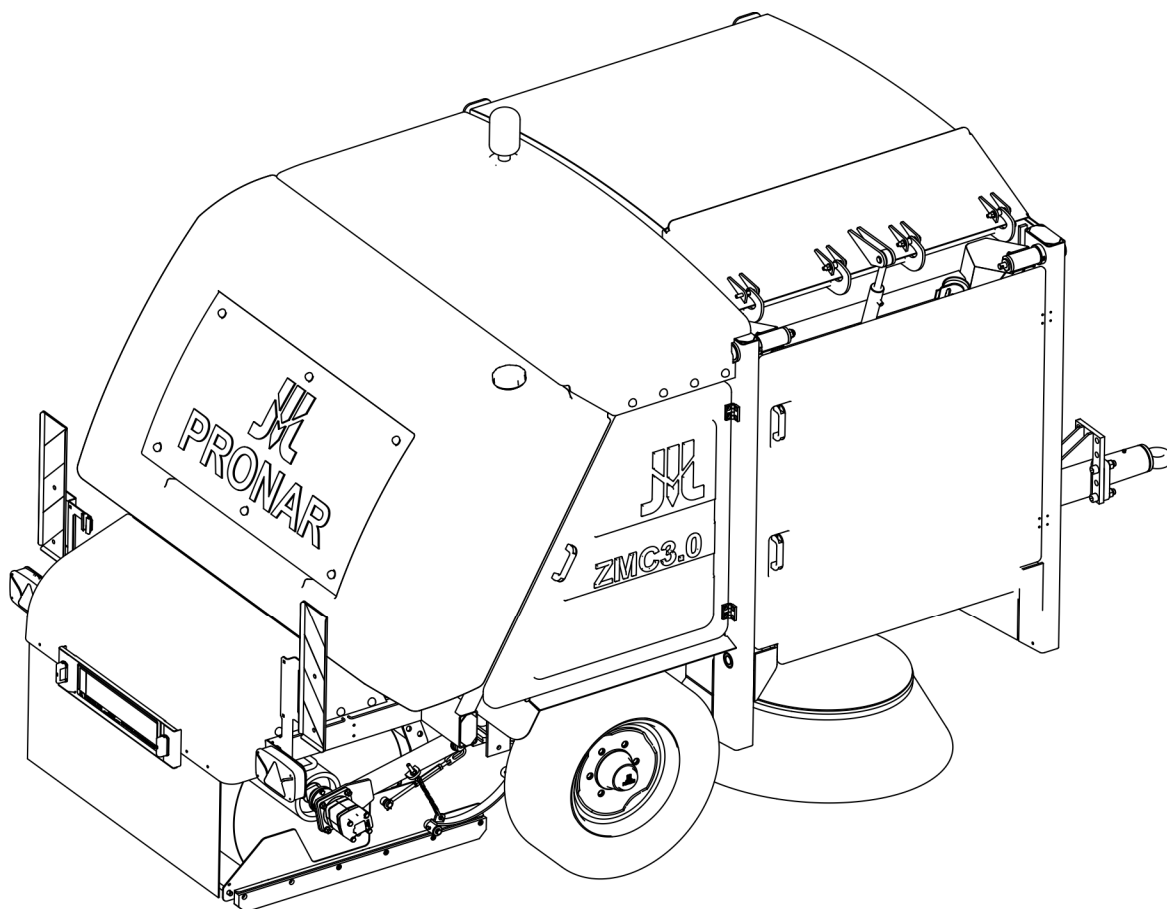

EDITION 1C-07-2013

PUBLICATION NO 344N-0000000-UM



INTRODUCTION

Information contained herein is current at date of publication. As a result of improvements, some numerical values and illustrations contained in this publication may not correspond to the factual specification of the machine supplied to the user. The manufacturer reserves the right to introduce design changes in machines produced that facilitate operation and improve the quality of their work, without making minor amendments to this Operator's Manual.

This Operator's Manual is an integral part of the machine's documentation. Before using the machine, the user must carefully read this Operator's Manual and observe all recommendations. This guarantees safe operation and ensures malfunction free work of the machine. The machine is designed to meet obligatory standards, documents and legal regulations currently in force.

The manual describes the basic safety rules and operation of the machine. If the information stated in the Operator's Manual needs clarification then the user should refer for assistance to the sale point where the machine was purchased or to the Manufacturer.

MANUFACTURER'S ADDRESS:

*PRONAR Sp. z o.o.
ul. Mickiewicza 101A
17-210 Narew*

CONTACT TELEPHONES

<i>+48 085 681 63 29</i>	<i>+48 085 681 64 29</i>
<i>+48 085 681 63 81</i>	<i>+48 085 681 63 82</i>

SYMBOLS APPEARING IN THIS OPERATOR'S MANUAL

Information, descriptions of danger and precautions and also recommendations and prohibitions associated with user safety instructions are marked:



and also preceded by the word "**DANGER**". Failure to observe the instructions may endanger the machine operator's or other person's health or life.

Particularly important information and instructions, the observance of which is essential, are distinguished in the text by the sign:



and also preceded by the word "**ATTENTION**". Failure to observe the instructions may lead to damage to the machine as a result of improper operation, adjustment or use.

In order to focus the user's attention on the need to perform maintenance, the relevant section of the Operator's Manual is marked with the pictogram:



Additional tips and advice for machine operation are marked:



and also preceded by the word "**TIP**".

DIRECTIONS USED IN THIS OPERATOR'S MANUAL

Left side – side to the left hand of the operator facing in the direction of machine's forward travel.

Right side – side to the right hand of the operator facing in the direction of machine's forward travel.



PRONAR Sp. z o.o.

ul. Mickiewicza 101 A

17-210 Narew, Polska

tel./fax (+48 85) 681 63 29, 681 63 81, 681 63 82,
681 63 84, 681 64 29

fax (+48 85) 681 63 83

http://www.pronar.pl

e-mail: pronar@pronar.pl

EC DECLARATION OF CONFORMITY OF THE MACHINERY

PRONAR Sp. z o.o. declares with full responsibility, that the machine:

Description and identification of the machinery	
Generic denomination and function:	Trailed sweeper
Type:	ZMC3.0
Model:	—
Serial number:	
Commercial name:	Trailed sweeper PRONAR ZMC3.0

to which this declaration relates, fulfills all the relevant provisions of the Directive **2006/42/EC** of The European Parliament and of The Council of 17 May 2006 on machinery, and amending Directive 95/16/EC (Official Journal of the EU, L 157/24 of 09.06.2006).

The person authorized to compile the technical file is the Head of Research and Development Department at PRONAR Sp. z o.o., 17-210 Narew, ul. Mickiewicza 101A, Poland.

This declaration relates exclusively to the machinery in the state in which it was placed on the market, and excludes components which are added and/or operations carried out subsequently by the final user.

Narew, the 21 CZE. 2012

Place and date

Z-CA DYREKTORA
d/s technicznych
członek zarządu
Roman Omelianiuk

Full name of the empowered person
position, signature

CONTENS

1	BASIC INFORMATION	1.1
1.1	IDENTIFICATION	1.2
1.2	PROPER USE	1.3
1.3	OPTIONAL EQUIPMENT	1.5
1.4	TERMS & CONDITIONS OF WARRANTY	1.5
1.5	TRANSPORT	1.7
1.6	ENVIRONMENTAL HAZARDS	1.9
1.7	WITHDRAWAL FROM USE	1.9
2	SAFETY ADVICE	2.1
2.1	BASIC SAFETY RULES	2.2
2.1.1	USE OF MACHINE	2.2
2.1.2	LINKING AND DISCONNECTING FROM TRACTOR	2.3
2.1.3	TRANSPORTING THE MACHINE	2.3
2.1.4	MAINTENANCE	2.4
2.1.5	MACHINE OPERATION	2.5
2.2	DESCRIPTION OF MINIMAL RISK	2.6
2.3	INFORMATION AND WARNING DECALS	2.7
3	DESIGN AND OPERATION	3.1
3.1	TECHNICAL SPECIFICATION	3.2
3.2	HYDRAULIC SYSTEM	3.3
3.3	PNEUMATIC BRAKE SYSTEM	3.5
3.4	PARKING BRAKE	3.9
3.5	SPRINKLER SYSTEM	3.10
3.6	ELECTRICAL SYSTEM	3.12

3.7 SWEEP SYSTEM	3.13
3.8 ELEVATOR AND WASTE TANK	3.14
4 CORRECT USE	4.1
4.1 PREPARING FOR WORK BEFORE FIRST USE	4.2
4.2 PREPARING FOR NORMAL OPERATION	4.3
4.3 HITCHING TO TRACTOR	4.4
4.3.1 CONNECTING THE MACHINE WITH THE TRACTOR HITCH	4.4
4.3.2 CONNECTING ELECTRICAL SYSTEM	4.7
4.3.3 CONNECTING BRAKE SYSTEM	4.8
4.3.4 CONNECTING THE HYDRAULIC INTENSIFIER WITH OIL PUMP	4.10
4.4 SWEEPER OPERATION	4.12
4.4.1 FILLING THE SPRINKLER SYSTEM TANK WITH WATER	4.12
4.4.2 CONTROL PANEL	4.13
4.4.3 SWEEPING	4.15
4.4.4 CONTROLLING THE SWEEPER'S TILTING DRAWBAR	4.15
4.4.5 OPERATION WITH ACTIVATED SPRINKLER SYSTEM	4.16
4.4.6 EMPTYING THE WASTE TANK	4.17
4.5 DRIVING ON PUBLIC ROADS	4.19
4.6 DISCONNECTING FROM TRACTOR	4.22
4.7 PROPER USE AND MAINTENANCE OF TYRES	4.24
5 MAINTENANCE	5.1
5.1 SERVICE INTERLOCK	5.2
5.2 ADJUSTMENT OF SWEEP UNIT AND ELEVATOR	5.3
5.2.1 ADJUSTMENT OF DISK BRUSHES	5.3
5.2.2 ADJUSTMENT OF ROLLER BRUSH	5.7
5.2.3 ADJUSTMENT OF ELEVATOR BELTS	5.9
5.3 REPLACEMENT OF BRUSHES AND ELEVATOR COMPONENTS	5.10

5.3.1	REPLACEMENT OF DISK BRUSHES	5.10
5.3.2	REPLACING THE ROLLER BRUSH	5.11
5.3.3	REPLACING THE ELEVATOR SCRAPERS	5.13
5.4	HYDRAULIC SYSTEM MAINTENANCE	5.14
5.5	SPRINKLER SYSTEM MAINTENANCE	5.24
5.6	ELECTRICAL SYSTEM MAINTENANCE	5.27
5.7	BRAKES ADJUSTMENT	5.29
5.7.1	ADJUSTMENT OF MAIN BRAKES	5.29
5.7.2	PARKING BRAKE ADJUSTMENT	5.30
5.8	PNEUMATIC SYSTEM MAINTENANCE	5.31
5.9	INSPECTION AND ADJUSTMENT OF WHEEL AXLE BEARINGS	5.35
5.10	LUBRICATION	5.36
5.11	STORAGE	5.42
5.12	TIGHTENING TORQUE FOR NUT AND BOLT CONNECTIONS	5.43

SECTION

1

**BASIC
INFORMATION**

1.1 IDENTIFICATION

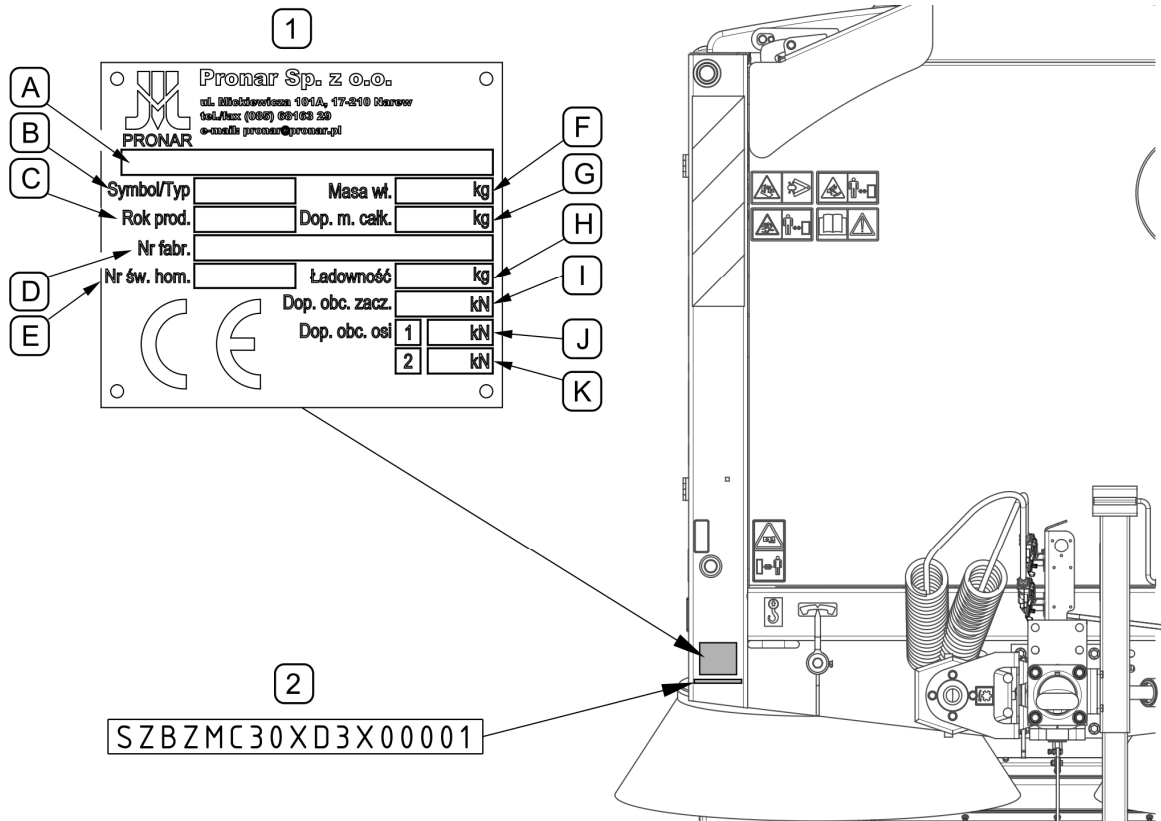

FIG. 1.1 Location of the data plate and serial number

(1) - data plate, (2) - serial number stamped into mounting base

TAB. 1.1 Markings on data plate

ITEM	MARKING
A	General description and purpose
B	Symbol /Machine type
C	Year of manufacture
D	Seventeen digit vehicle identification number (VIN)
E	Official certificate number
F	Machine tare weight
G	Maximum gross weight
H	Carrying capacity
I	Permissible hitching system loading
J	Permissible axle 1 load
K	Permissible second axle load - <i>not applicable</i>

The machine is marked with the data plate (1), and the factory number (2) located on a rectangle area below data plate (FIG. 1.1). Data plate and factory number are located on the front wall beam on the right side of the machine (FIG. 1.1). When buying the machine check that the serial numbers on the machine agree with the number written in the *WARRANTY BOOK*, in the sales documents and in the *OPERATOR'S MANUAL*. The meanings of the individual fields found on the data plate are presented in TAB. 1.1.

1.2 PROPER USE

PRONAR ZMC3.0 sweeper is used for sweeping hard-surfaced streets (cobblestone, asphalt, concrete) and large areas such as yards, parking spaces, warehouse areas. Use for other purposes should be regarded as improper.

The sweeper is designed for operation with agricultural tractors and other carrying vehicles that meet the requirements contained in Table 1.2

Using it as intended also involves all actions connected with the safe and proper operation and maintenance of the machine. Due to the above, the user is obliged to:

- carefully read the OPERATOR'S MANUAL and comply with its recommendations,
- understand the machine's operating principle and how to operate it safely and correctly,
- comply with general safety regulations while working,
- prevent accidents,
- comply with road traffic regulations.

The machine may only be used by persons, who:

- are familiar with the contents of this publication and with the contents of the tractor Operator's Manual,
- have been trained in machine operation and safe working conditions,
- have the required authorisation to drive and are familiar with the road traffic regulations and transport regulations.

**IMPORTANT!**

The sweeper must not be used for purposes other than those for which it is intended, in particular for transporting people and animals.

TAB. 1.2 Requirements for carrying vehicle (agricultural tractor)

	UNIT	REQUIREMENTS
Brake system *		
Double line pneumatic system	-	sockets compliant with PN-ISO 1728:2007
Pressure rating of the system	kPa	600
Electrical system		
Lighting system socket	-	7 polar compliant with ISO 1724
Electrical system voltage	V	12
Power take-off shaft		
Type of shaft	-	Type 1 according to ISO 500 Ø35 mm, 6 splines
Nominal rotation speed of PTO	RPM	540
PTO rotation direction	-	clockwise (<i>looking at the shaft front in the carrying vehicle</i>)
Power demand on PTO shaft	kW / Horsepower	35 / 47.5
Hitch		
Type of hitch	-	non-rotating lower transport hitch, fork type, Piton Fix or hook (located under PTO shaft)
Drawbar eye diameter	mm	Ø 50
Vertical load capacity of hitch	kg	1 700

* - *Optionally, the sweeper can be equipped with single conduit pneumatic system or hydraulic brake system.*

1.3 OPTIONAL EQUIPMENT

The sweeper equipment includes:

- Operator's Manual,
- Warranty Book,
- control panel,
- 7-pole connection lead

Additional (optional) equipment:

- vibrator system (*facilitates waste tank emptying*)
- working lights (*illuminate the operating zone of the side brushes*)
- complete beam (*additional warning lights installed at the rear of the sweeper and C9/C10 mandatory sign*)
- additional beacon light (*additional beacon light installed on the right side of the machine*)
- clearance boards (*installed at the rear of the sweeper*)
- hydraulic tilting of the left brush (*controlling the left brush from the operator cab using the control panel*)
- bracket of complete license plate (*fixing the license plate and its lights*)
- set of wheel chocks

1.4 TERMS & CONDITIONS OF WARRANTY

PRONAR Sp. z o.o., Narew guarantees the reliable operation of the machine when it is used according to its intended purpose as described in the *OPERATOR'S MANUAL*. Defects discovered during the warranty period will be removed by the Warranty Service. The repair period is specified in the *WARRANTY BOOK*.

The warranty does not apply to those parts and sub-assemblies of the machine, which are subject to wear in normal usage conditions, regardless of the warranty period. Consumables include the following parts/sub-assemblies:

- brushes;
- slides, scrapers, rubber shields
- elevator wheels
- bearings
- filters
- light bulbs, fuses

The warranty service only applies to factory defects and mechanical damage that is not due to the user's fault.

In the event of damage arising from:

- mechanical damage which is the user's fault, caused by road accidents,
- by inappropriate use, adjustment or maintenance, use of the machine for purposes other than those for which it is intended,
- use of damaged or malfunctioning machine,
- repairs carried out by unauthorised persons, improperly carried out repairs,
- making unauthorised alterations to machine design,

the user will lose the right to warranty service.



TIP

Demand that the seller carefully and precisely fills out the *WARRANTY BOOK* and warranty repair coupons. A missing date of purchase or sale point stamp, may make the user ineligible for any warranty repair or refund.

For detailed Terms & Conditions of Warranty, please refer to the *WARRANTY BOOK* attached to each machine.

Modification of the machine without the written consent of the Manufacturer is forbidden. In particular, do NOT weld, drill holes in, cut or heat the main structural elements, which have a direct impact on the machine operation safety.

1.5 TRANSPORT

DANGER



When transporting independently, the user must carefully read this Operator's Manual and observe all recommendations. When being transported on a motor vehicle the machine must be mounted on the vehicle's platform in accordance with the transport safety requirements. The driver of the vehicle should take particular care while transporting the machine. This is due to the vehicle's centre of gravity shifting upwards when loaded with the machine.

The machine is prepared for sale completely assembled and does not require packing. Packing is only required for the machine operator's manual and electrical system components.

Delivery is either by transport on a vehicle or independently, after being attached to a tractor. Transportation of the machine is connected to a permissible tractor provided the vehicle's driver familiarises himself with the machine's Operator's Manual and particularly with safety information and Concerning the Principles of connection and transportation on public roads.

During road transport the machine should be secured on the carrier platform by certified belts or chains fitted with pulley.

Side shield covers should be additionally secured against opening with band clips.

When loading and unloading the machine, comply with the general principles of workplace health and safety for reloading work. Persons operating reloading equipment must have the qualifications required to operate these machines.

During reloading work, particular care should be taken not to damage parts of the fittings or the lacquer coating. Chocks or other objects without sharp edges should be placed under the wheels to prevent it from rolling. Chocks should be fixed to load platform. Sweeper has four points (FIG. 1.2) for fixing it to the load platform.

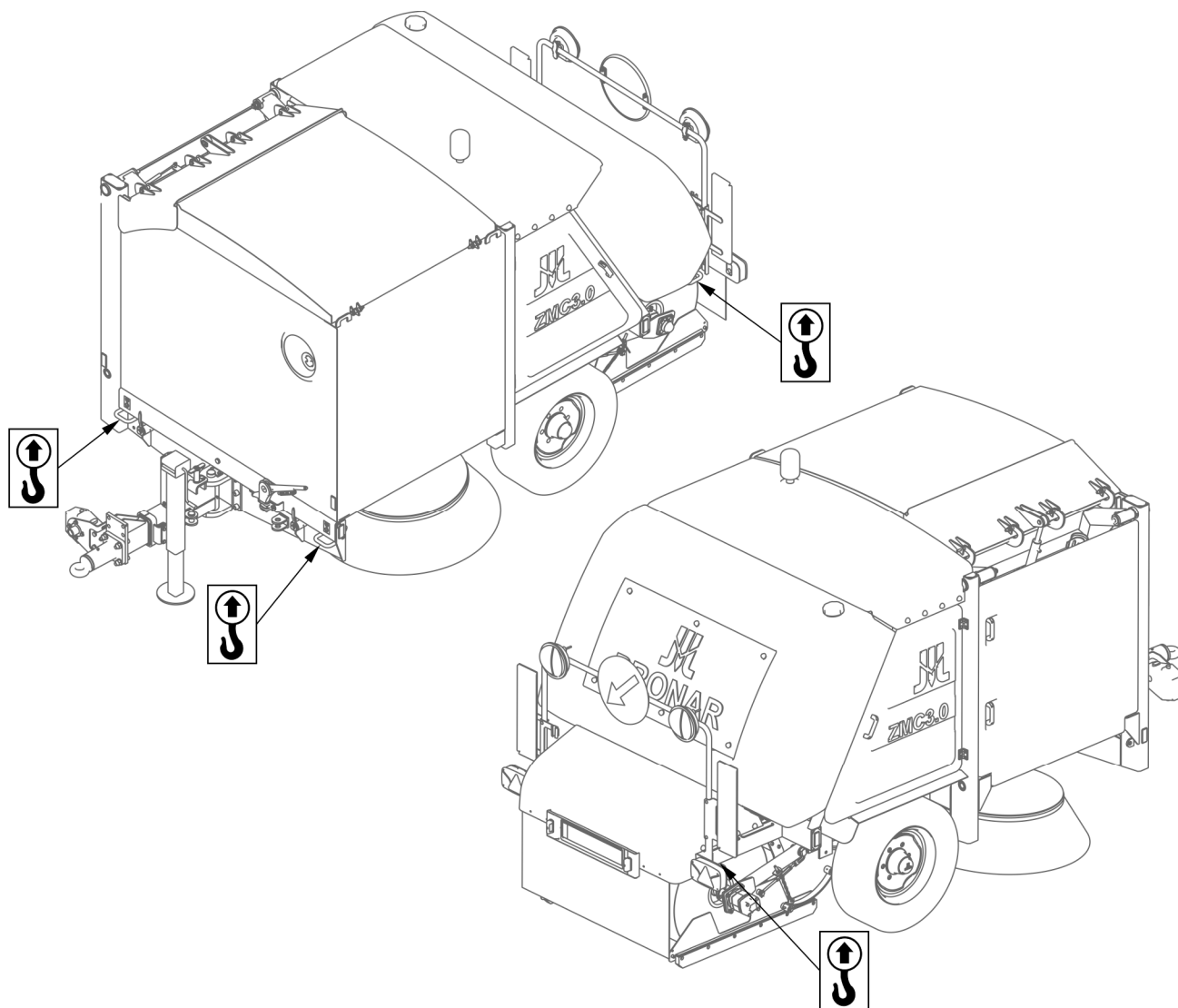

FIG. 1.2 **Fixing points for the transport**



ATTENTION!

Do NOT secure lifting slings or any types of securing elements to hydraulic cylinders.

1.6 ENVIRONMENTAL HAZARDS

A hydraulic oil leak constitutes a direct threat to the natural environment owing to its limited biodegradability. Maintenance and repair work which involves the risk of a leak should be performed in the rooms with oil resistant surface. In the event of lubricant leaking into the environment, first of all contain the source of the leak, and then collect the leaked lubricant using available means. Remaining lubricant should be collected using sorbents, or by mixing the oil with sand, sawdust or other absorbent materials. The lubricant pollution, once gathered up, should be kept in a sealed, marked, hydrocarbon resistant container, and then passed on to the appropriate oil waste recycling centre. The container should be kept away from heat sources, flammable materials and food.

Oil, which has been used up or is unsuitable for further use owing to a loss of its properties should be stored in its original packaging in the conditions described above.

1.7 WITHDRAWAL FROM USE

In the event of decision by the user to withdraw the machine from use, comply with the regulations in force in the given country concerning withdrawal from use and recycling of machines withdrawn from use.

Before proceeding to dismantle machine, oil shall be completely removed from hydraulic system.

When spare parts are changed, worn out or damaged parts should be taken to a collection point for recyclable raw materials. Waste oil, hydraulic lines, electrical system components and plastic elements should be taken to the appropriate facility dealing with the recycling of this type of waste.



IMPORTANT!

During dismantling personal protection equipment shall be used i.e. protective clothing, boots, gloves and protective goggles etc.

Avoid contact of skin with oil. Do not allow used lubricants to spill.

SECTION

2

SAFETY ADVICE

2.1 BASIC SAFETY RULES

2.1.1 USE OF MACHINE

- Before using the machine, the user must carefully read this Operator's Manual and the *WARRANTY BOOK*. When operating the machine, the operator must comply with the recommendations.
- The machine may only be used and operated by persons qualified to drive agricultural tractors and agricultural machines and trained in the use of the machine.
- If the information stated in the Operator's Manual is difficult to understand, contact a seller, who runs an authorised technical service on behalf of the manufacturer, or contact the manufacturer directly.
- Be aware of the existence of a minimal risk, and for this reason the fundamental basis for using this machine should be the application of safety rules and sensible behaviour.
- The machine must never be used by persons, who are not authorised to drive agricultural tractors, including children and people under the influence of alcohol or other drugs.
- Non-compliance with the safety rules of this Operator's Manual can be dangerous to the health and life of the operator and others.
- The machine must not be used for purposes other than those for which it is intended. Anyone who uses the machine other than the way intended takes full responsibility for himself for any consequences of this use. Use of the machine for purposes other than those for which it is intended by the Manufacturer may invalidate the warranty.
- The machine may only be used when all the protective elements (i.e.. safety guards, bolts, cotter pins) are technically sound and correctly positioned. In the event of loss or destruction of the safety guards, they must be replaced with new ones.

- Before hitching the machine to the tractor, always check the technical condition of the hitching system, connection elements of the braking system and electrical system of the carrying vehicle and the machine.

2.1.2 LINKING AND DISCONNECTING FROM TRACTOR

- Carefully read the Operator's Manual of the sweeper's carrying vehicle.
- To mount machine on carrying vehicle use only genuine pins and safeguard cotter pins.
- The agricultural tractor to which the machine will be coupled must be technically reliable and must fulfil the requirements of machine Manufacturer.
- Be especially careful when hitching the machine to tractor.
- After completion of coupling the machine, check the safeguards.
- Be especially careful when disconnecting the machine from the carrying vehicle.
- Do not disconnect the sweeper from the tractor if the waste tank is open or raised.
- The machine unhitched from carrying vehicle must be immobilised with parking brake. If the machine is positioned on a slope or elevation it should be additionally secured against moving by placing chocks under the machine's wheels.

2.1.3 TRANSPORTING THE MACHINE

- Before driving on public roads, check operation of indicator lights.
- While driving on public roads the machine shall be marked with a warning triangle distinguishing slow-moving vehicles. The warning triangle should be attached to the rear of the machine.
- When driving on public roads, comply with the road traffic regulations. in force in the country, in which the machine is used.
- Do not exceed the permitted speed arising from road conditions and design limitations. Adjust travel speed to the prevailing road conditions and other limitations arising from road traffic regulations limits.
- Do not exceed maximum design speed.
- Do NOT leave machine raised and unsecured while the tractor is parked.

- Do NOT travel with raised or open waste tank.
- The machine must never be used for transport of people, animals and other items.
- Reckless driving and excessive speed may cause accidents.

2.1.4 MAINTENANCE

- During the warranty period, any repairs may only be carried out by Warranty Service authorised by the manufacturer. It is recommended that necessary repairs to machine should be undertaken by specialised workshops.
- In the event of any fault or damage whatsoever, do not use the machine until the fault has been corrected.
- During work, use proper protective clothing, gloves and appropriate tools.
- Any modification to the machine frees PRONAR from any responsibility for damage or detriment to health which may arise as a result.
- Regularly check the technical condition of the safety devices and correct tightening of bolt connections.
- Regularly perform service inspections of machine as recommended by the Manufacturer.
- Do NOT perform service or repair work under raised and unsupported machine.
- Servicing and repair work should be carried out in line with the general principles of workplace health and safety. In the event of injury, the wound must be immediately cleaned and disinfected. In the event of more serious injuries, seek a doctor's advice.
- Repair, maintenance and cleaning work should be carried out with the carrying vehicle engine turned off and the ignition key removed. Immobilise machine with parking brake. Ensure that unauthorised persons do not have access to the vehicle.
- Switch off the machine and install supports and service safety devices before performing any maintenance, adjustment and repair activities near the raised waste tank.

- Should it be necessary to change individual parts, use only original parts. Non-adherence to these requirements may put the user and other people's health and life at risk, and also damage the machine and invalidate the warranty.
- Do NOT weld, drill holes in, cut or heat the main structural elements, which have a direct impact on the machine operation safety.
- In the event of work requiring the machine to be raised, use properly certified hydraulic or mechanical lifts for this purpose. After lifting the machine, stable and durable supports must also be used. Do NOT carry out work under a machine, which has only been raised with the lift jack.
- Do not modify pressure in machine's systems on forfeit of warranty rights.
- The machine must not be supported using fragile elements (bricks or concrete blocks).
- After completing work associated with lubrication, remove excess oil or grease.
- In order to reduce the danger of fire the machine must be kept in a clean condition.

2.1.5 MACHINE OPERATION

- Before starting the carrying vehicle with connected machine make sure the PTO drive is not engaged, otherwise it can lead to uncontrolled operation of the machine.
- Before activating the machine, always ensure that all the safety guards are in good condition and in place.
- Before starting the machine, make sure that there are no bystanders (especially children) or animals in danger zone and inside the machine. The machine operator is obliged to ensure proper visibility of the machine and the working area.
- During machine operation do not occupy a different position than that of the operator in the vehicle's cab. Do NOT leave the cab, when the machine is in operation.
- Do NOT stand within the machine's working zone and also between the carrying vehicle and the machine when the carrying vehicle's engine is working.

- Do not approach rotating brushes.
- Waste tank emptying should be carried out on a level and sufficiently hard surface, using stabilising props. Otherwise, the machine may tip over.
- Before lifting the tank, make sure there are no bystanders near the machine.
- Waste tank may be raised only when the machine is parked.
- Keep a safe distance from electric power lines while emptying the waste tank.
- Waste tank must not be left in raised position if service interlocks are not installed.

2.2 DESCRIPTION OF MINIMAL RISK

Pronar Sp. z o.o. in Narew has made every effort to eliminate the risk of accidents. There is, however, a certain minimal risk, which could lead to an accident, and this is connected mainly with the actions described below:

- using the sand spreader for purposes other than those for which it is intended,
- being between the tractor and the machine while the engine is running and when the machine is being attached;
- operation of the machine by persons under the influence of alcohol;
- being on the machine when it operates,
- being near moving elements of the machine;
- operating the machine with removed or faulty safety guards;
- cleaning, maintenance and technical checks when tractor is connected and engine is running;
- making modifications to the machine without the consent of the Manufacturer;
- oil leaks and sudden movement of elements resulting from line cracking;
- possibility of trapping persons or animals inside the waste tank;
- presence of persons or animals in areas invisible from the driver's position;
- transport of persons or animals on or inside the machine;
- exceeding permissible travel speed.



The minimal risk may be kept to a minimum by following the recommendations below:





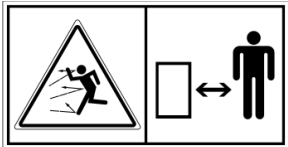

- prudent and unhurried operation of the machine,
- application of the remarks and recommendations stated in the Operator's Manual;
- maintaining safe distance from the danger zone
- assistance of third persons while manoeuvring the machine, due to limited visibility from the driver's position;
- carrying out repair and maintenance work in line with operating safety rules,
- using suitable protective clothing
- ensuring unauthorised persons have no access to the machine, especially children;
- a ban on being on the machine when it is operating.

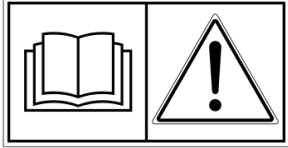
2.3 INFORMATION AND WARNING DECALS

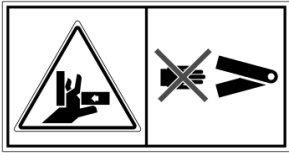
All signs should always be legible and clean, visible to the operator and also to persons possibly being in the vicinity of the machine in operation. If any safety sign is lost or illegible, it should be replaced with a new one. All elements having safety signs replaced during repairs should be affixed with these signs. Safety signs and decals may be purchased from the Manufacturer or the Seller.

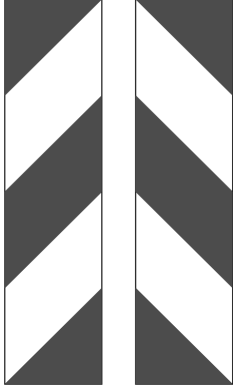
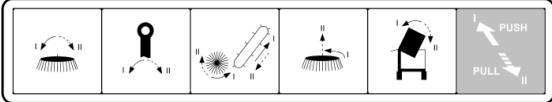
TAB. 2.1 Information and warning decals

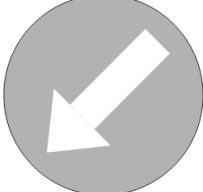
ITEM	SYMBOL	DESCRIPTION
1		Danger caused by materials thrown out by the machine. Keep a safe distance from the operating machine.
2		Pressurised liquid. Keep a safe distance from the operating machine.
3		Before starting work, carefully read the Operator's Manual.

ITEM	SYMBOL	DESCRIPTION
4		Do not reach into crushing space if elements may move.
5		Fixing points for the transport
6		Danger of crushing to feet. Keep a safe distance from the operating machine.
7,8		Front clearance marking Rear clearance marking (option) Side clearance marking (option)
9		Marking of manifold lever functions
10		Rotation speed of PTO shaft
11		Scale of brush inclination indicator
12		Rear marking. C9/C10 sign (option)
13		Marking of water filler and water drain valve
14		Required rotation direction of PTO shaft in the machine

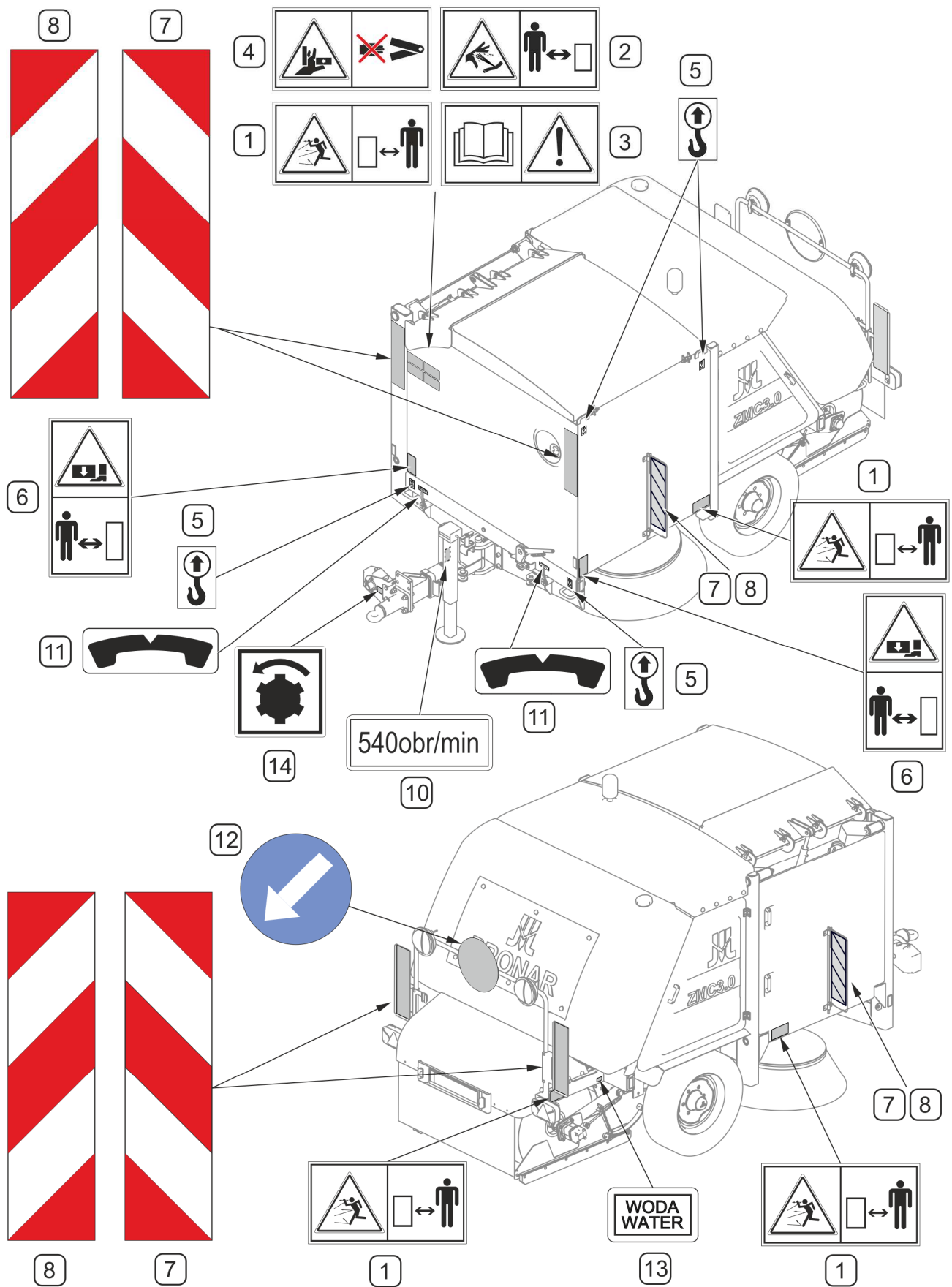

FIG. 2.1 Locations of information and warning decals.

Meaning of symbols (TAB. 2.1)

SECTION

3

**DESIGN AND
OPERATION**

3.1 TECHNICAL SPECIFICATION

TAB. 3.1 BASIC TECHNICAL DATA OF THE ZMC 3.0 SWEEPER

	Unit	
Technical specification		
Sweeping width	mm	2,400 – 2,700 (adjustable)
Working speed	km/h	1 – 20 (depending on amount of waste)
Waste tank capacity	m ³	3
Tare weight (without water)	kg	3,150
Hydraulic system		
Oil tank capacity	L (dm ³)	190
Nominal pressure in the system	MPa	16
Type of oil	-	hydraulic, L-HL32
Sweep unit		
Disk brushes	-	2 pcs D=1,100mm, d=760mm; H=260mm
Roller brush	-	1 pcs D=750mm, L=1,100mm
Sprinkler system		
Water tank capacity	L (dm ³)	1,150
Maximum water pressure	MPa (bar)	0.3 (3)
Dimensions		
Length	mm	4,730 - 4,850 (depending on drawbar position)
Width	mm	2,060
Height	mm	2,480
Emptying height	mm	2,200
Height with a raised tank	mm	4,420
Tyres		
Tyres	-	235/75R17,5 143/141J
Wheel rim	-	6.75X17.5 161/205/6 OTW., ET=0
Other information		
Transport speed (maximum) / design speed	km/h	25 / 40
Maintenance	-	single person operation

3.2 HYDRAULIC SYSTEM

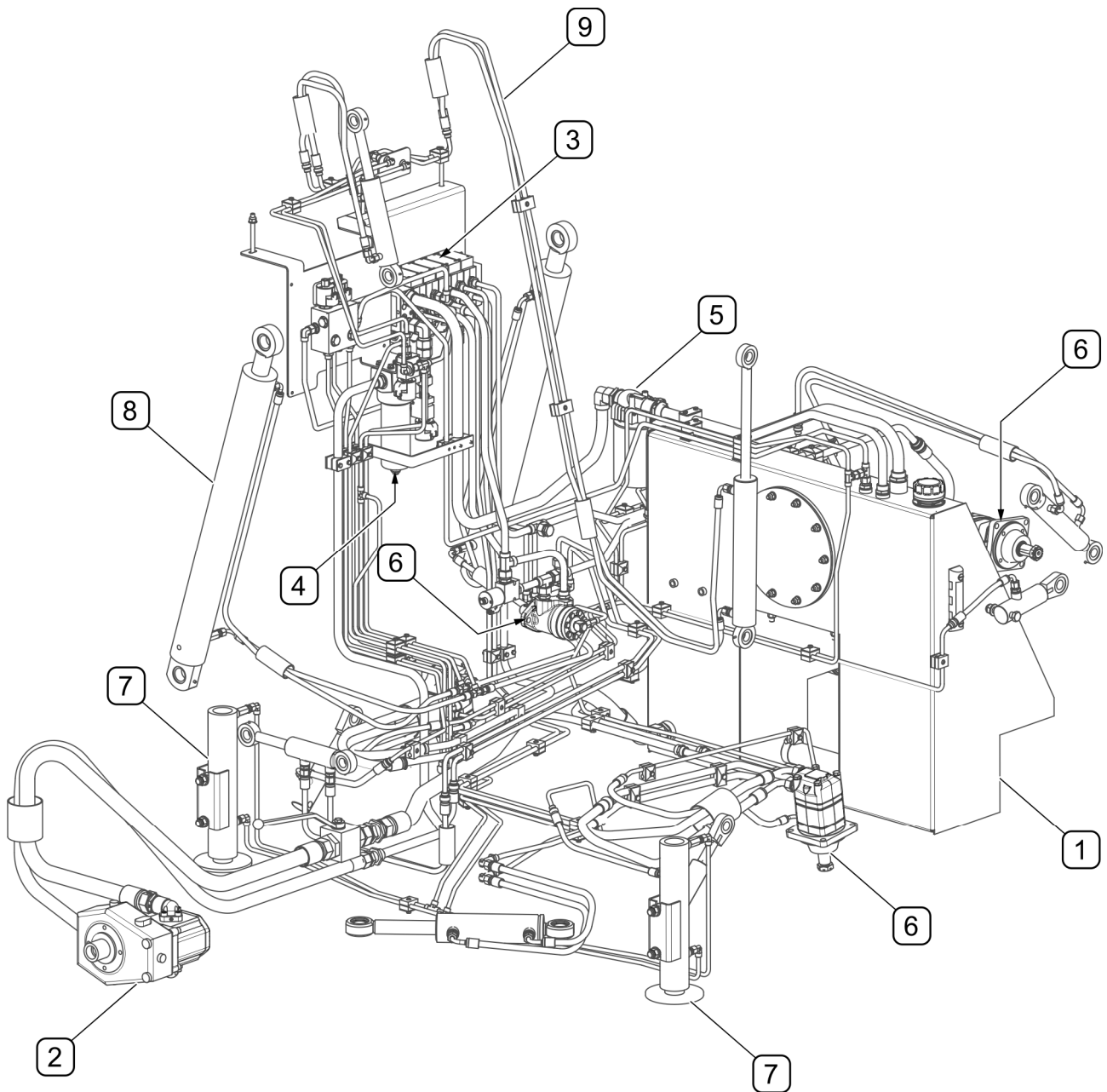

FIG. 3.1 Hydraulic system design

(1) - oil tank; (2) - hydraulic intensifier with oil pump; (3) - manifold; (4) - pressure oil filter;
(5) - return oil filter; (6) - hydraulic motor; (7) - hydraulic supports; (8) - hydraulic cylinder

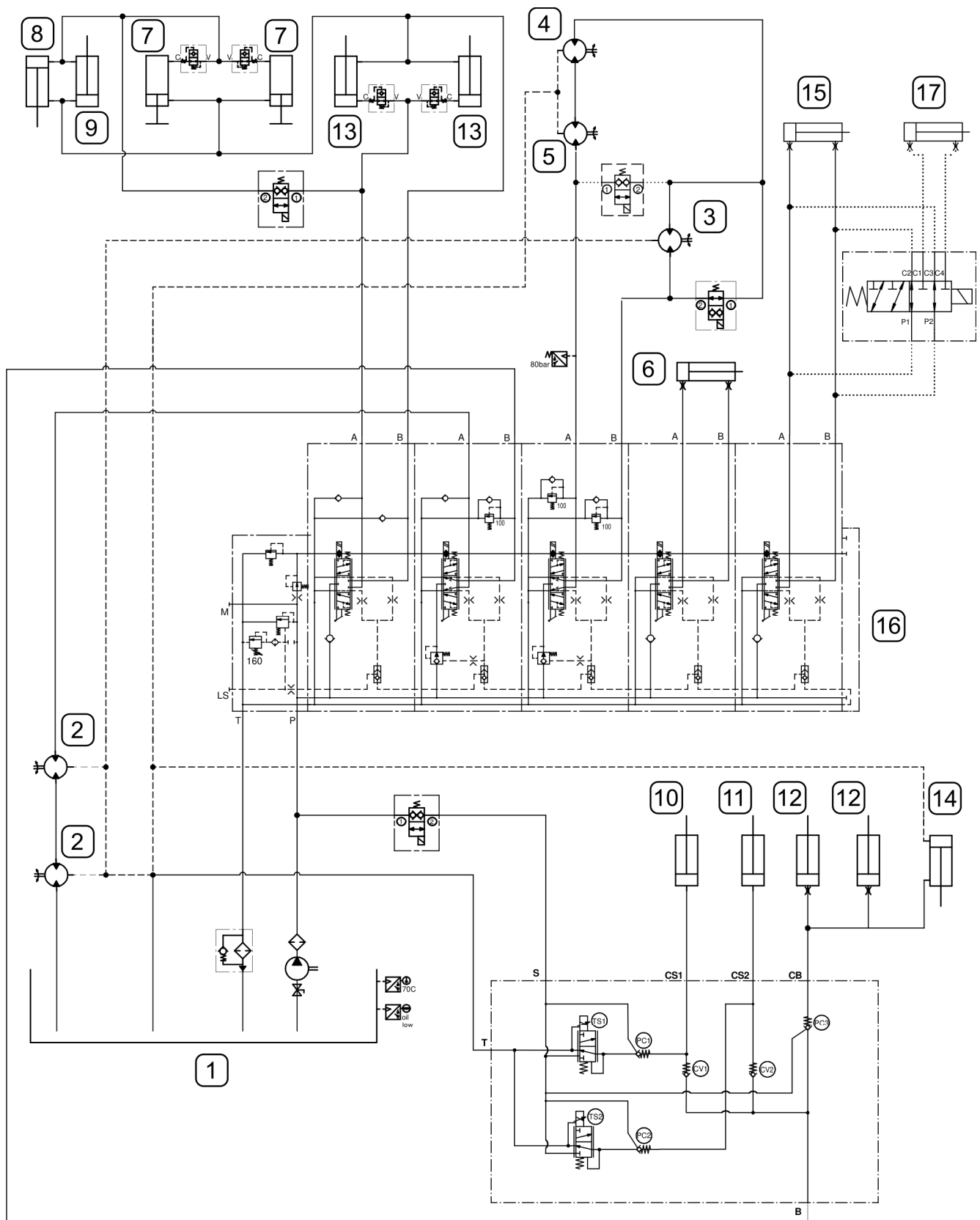

FIG. 3.2 Hydraulic system concept diagram

(1) - oil tank; (2) - hydraulic motor of disk brush; (3) - hydraulic motor of water pump;
 (4) - hydraulic motor of roller brush; (5) - hydraulic motor of elevator; (6) - hydraulic cylinder of drawbar; (7) - hydraulic support; (8) - slide bolt cylinder; (9) - tank cover cylinder; (10) - right

brush rising cylinder; (11) - left brush rising cylinder; (12) - elevator rising cylinder; (13) - tank rising cylinder; (14) - roller brush cylinder; (15) - right brush tilting cylinder; (16) - manifold; (17) - left brush tilting cylinder

3.3 PNEUMATIC BRAKE SYSTEM

Depending on version, ZMC3.0 sweeper can be equipped with one of the two types of pneumatic brake systems (FIG. 3.4):

- double line pneumatic system (A),
- single line pneumatic system (B)

The main brake is activated from the tractor driver's position by pressing on the brake pedal. Control valve (2) activates the sweeper's pneumatic brake system when the brake pedal is pressed in the tractor. Additionally, in the event of accidental disconnection of the pneumatic line between the tractor and sweeper, the brake valve will automatically activate the machine brakes. The brake valve is equipped with the brake release system to be used when the sweeper is disconnected from the tractor. In order to switch off pneumatic brakes, pull out the handle next to control valve (2).

When the supply line is connected to the tractor, the brake release system automatically changes its position to allow normal brake operation.

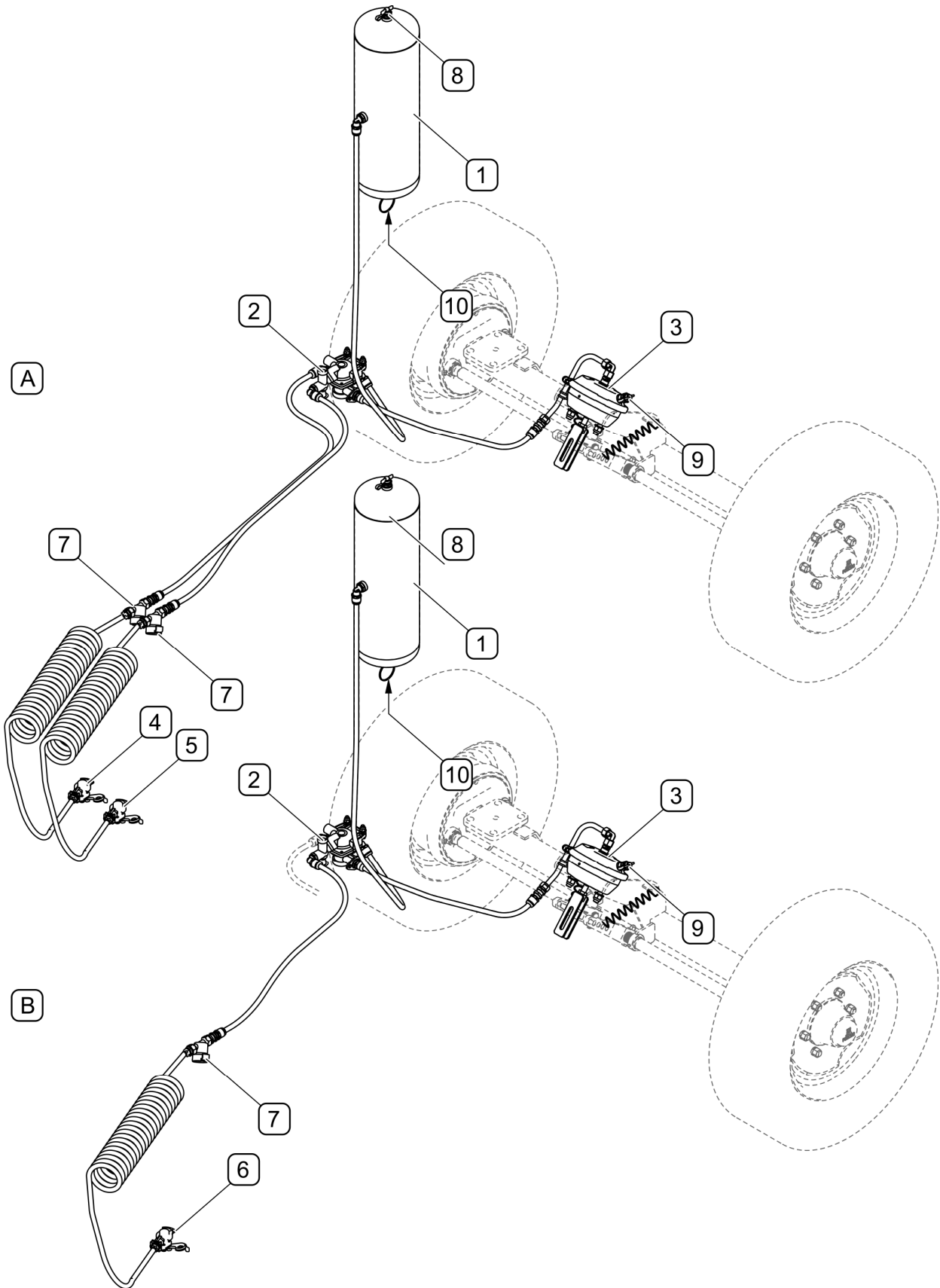

FIG. 3.3 Design of the double line pneumatic brake system

(A) - double line system; (B) - single line system; (1) - air tank; (2) - control valve; (3) - pneumatic cylinder; (4) - "yellow" connection; (5) - "red" connection; (6) - "black"

connection; (7) - air filter; (8)- tank control connection; (9) - cylinder control connection, (10) - drain valve

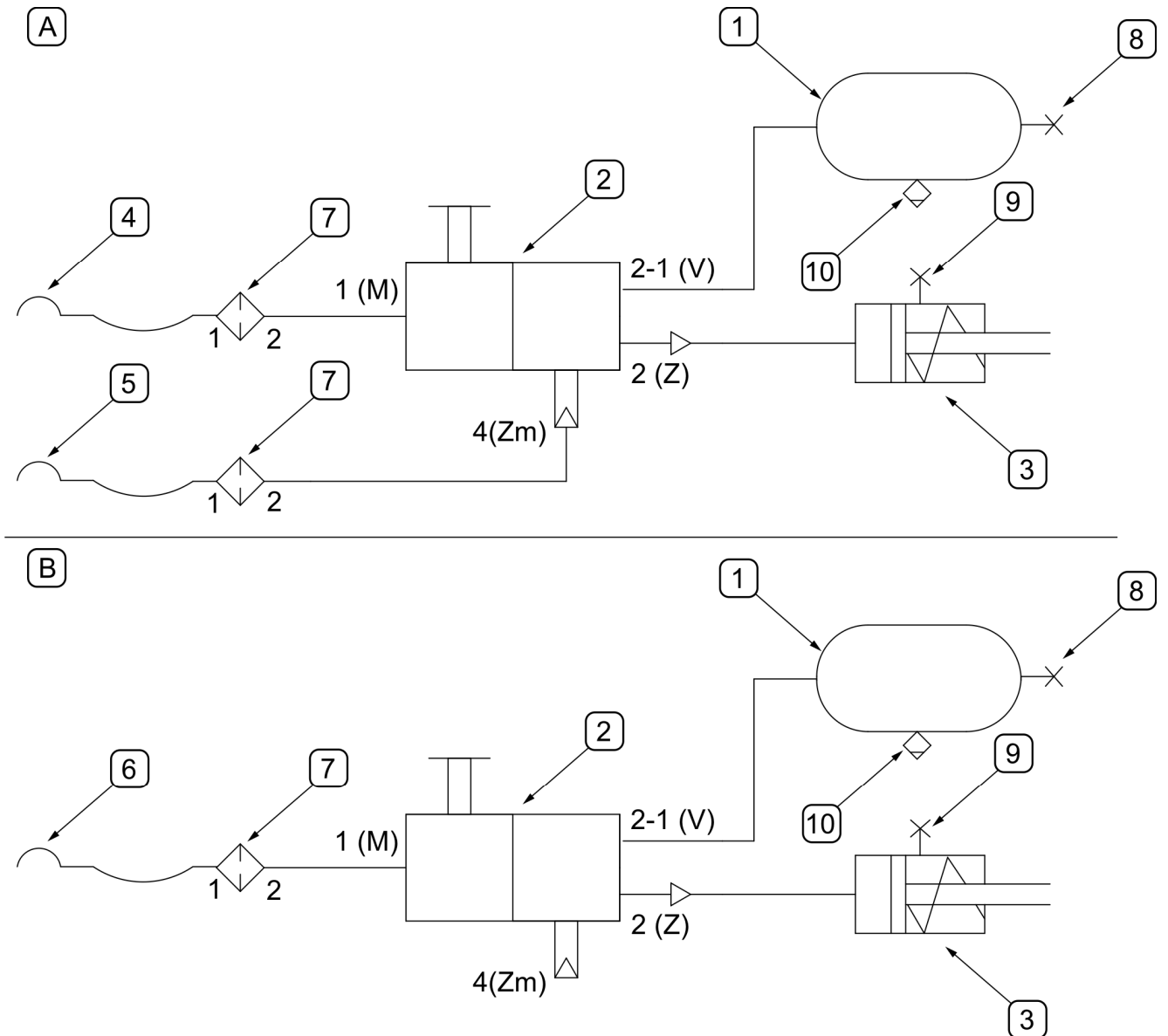

FIG. 3.4 Pneumatic system design

(A) - double line system; (B) - single line system; (1) - air tank; (2) - control valve; (3) - pneumatic cylinder; (4) - "red" connection; (5) - "yellow" connection; (6) - "black" connection; (7) - air filter; (8) - tank control connection; (9) - cylinder control connection; (10) - drain valve

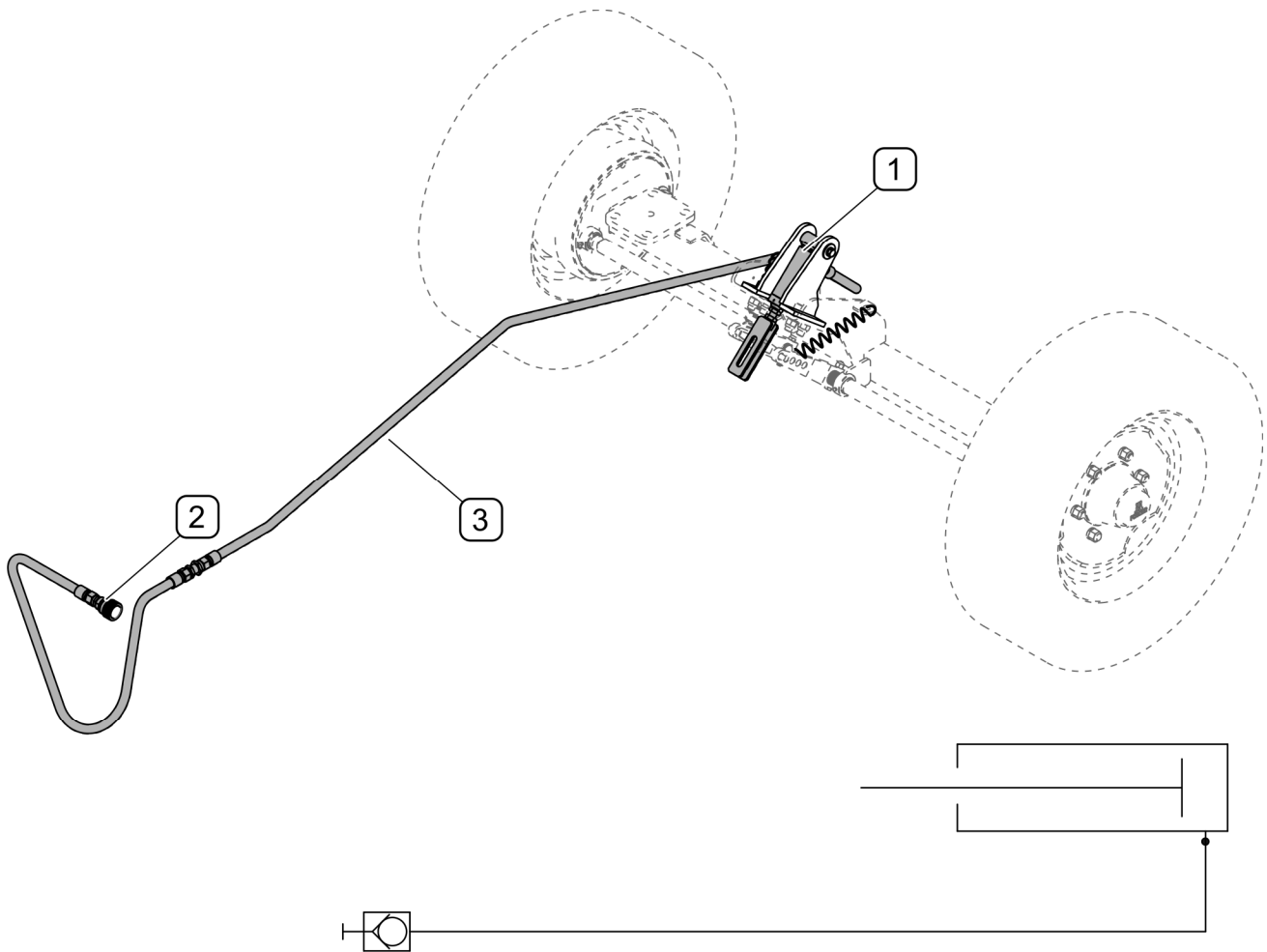

FIG. 3.5 Design of hydraulic brake system (option)

(1) - hydraulic cylinder; (2) - quick coupler; (3) - hydraulic line

Optionally, the sweeper can be equipped with hydraulic brake system (FIG. 3.5) that consists of hydraulic cylinder (1), quick coupler (3) and hydraulic conduit (3).

3.4 PARKING BRAKE

Parking brake control mechanism (FIG. 3.6) is located at the front of the sweeper's frame, and is used for immobilising the machine while standing motionless. The brake is applied by rotating crank mechanism (1) clockwise. The mechanism tightens the steel cable (2) and causes tilting of the expander lever, which parts the jaws of the brake shoes immobilising the machine. In order to release the brake, turn the crank of the brake's mechanism anticlockwise.

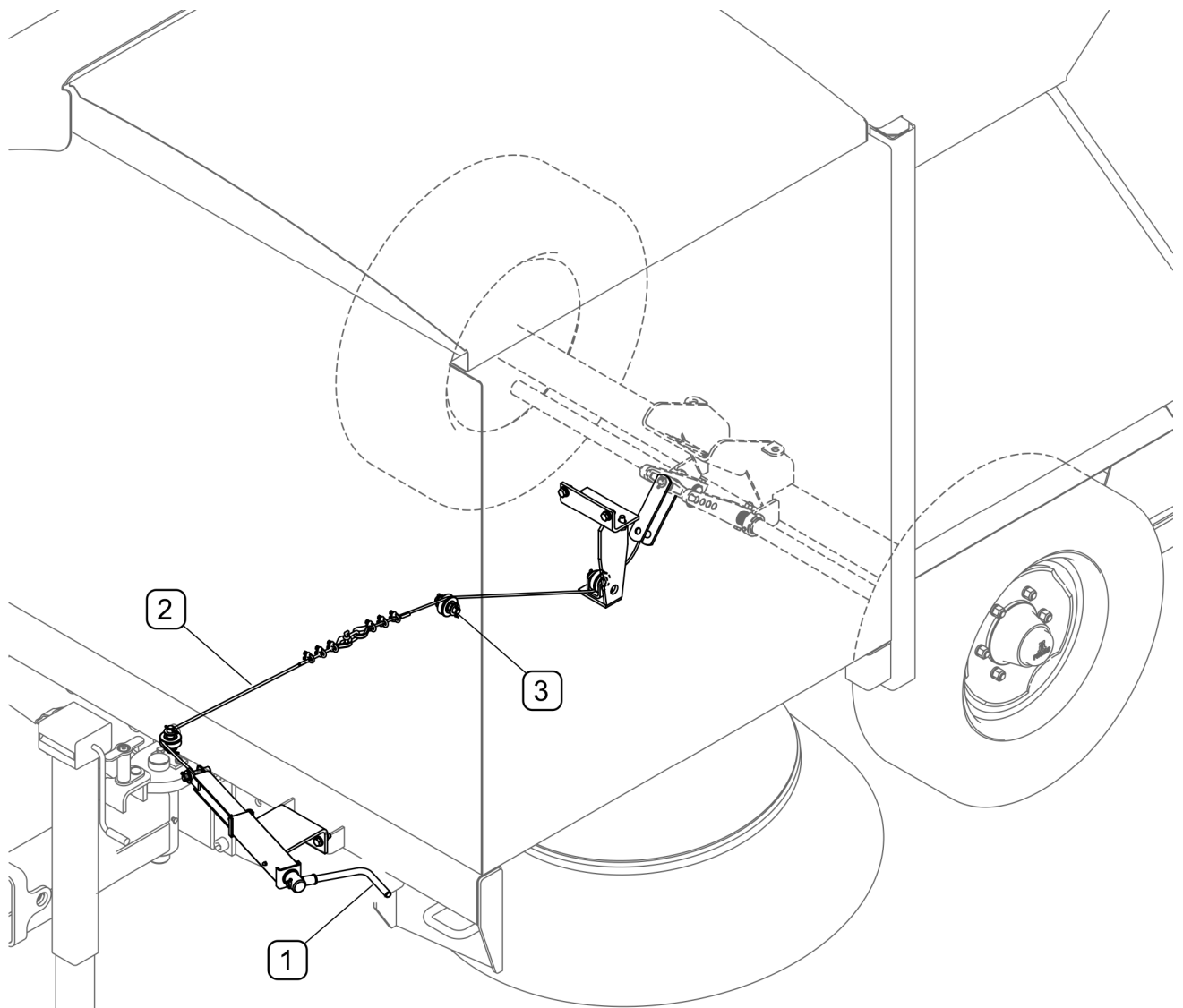

FIG. 3.6 Parking brake

(1) - brake crank mechanism; (2) - cable; (3) - guide rollers

3.5 SPRINKLER SYSTEM

Sprinkler system (FIG. 3.7) prevents dusting during machine operation. Water tank (1) and pump (2) are the main elements of the system. Sprinkling nozzles (6) and sprinkling beam (9) are located in front of brushes and above the elevator. Some of the sprinklers can be switched off by means of valves (7). The sprinkler system is switched on and off from the control panel by activating solenoid valve (4).

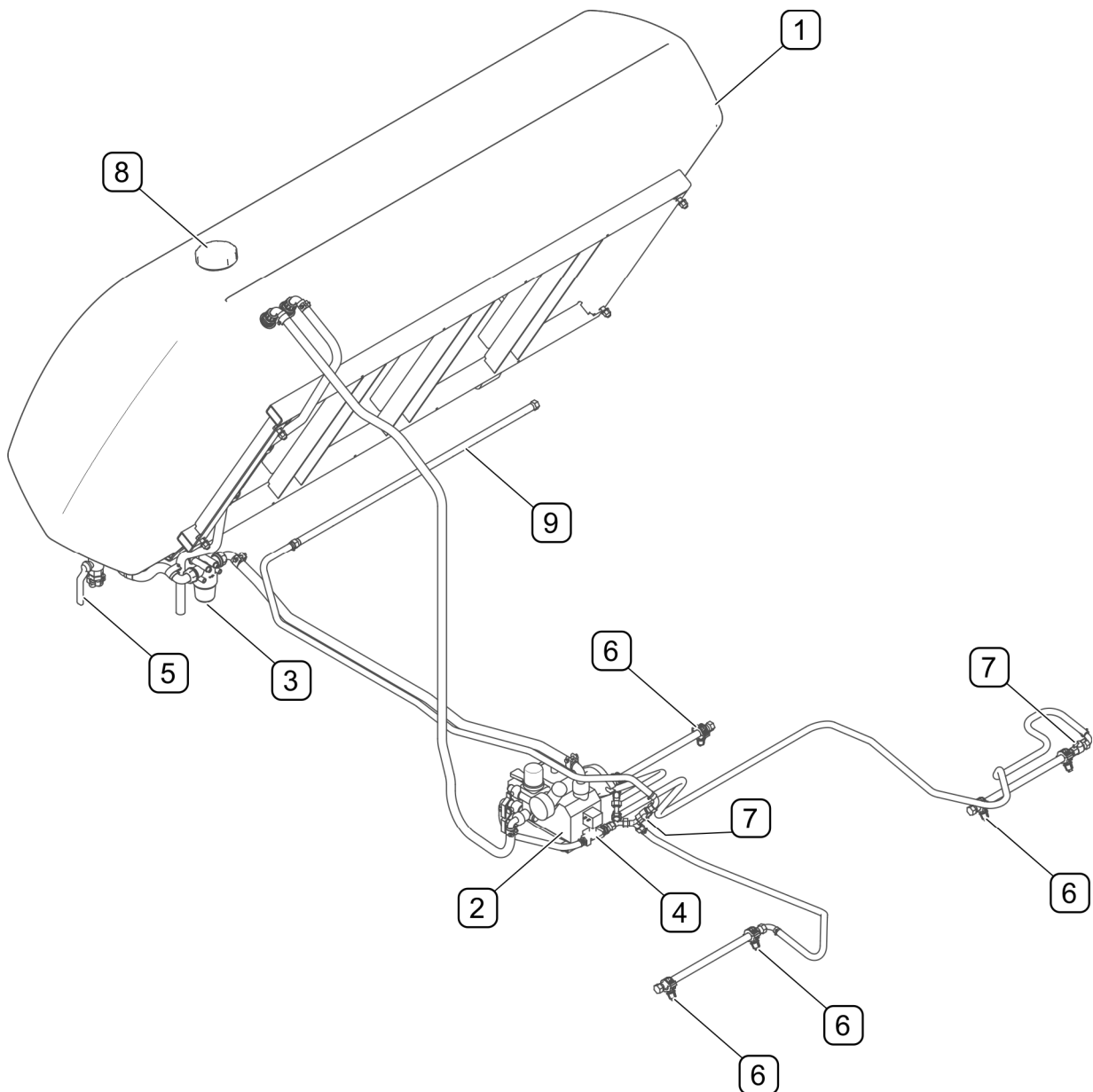

FIG. 3.7 Sprinkler system design

(1) - water tank; (2) - water pump; (3) - filter; (4) - solenoid valve; (5) - drain valve with filling connection; (6) - sprinkling nozzles; (7) - valve; (8) - filler plug; (9) - sprinkling beam

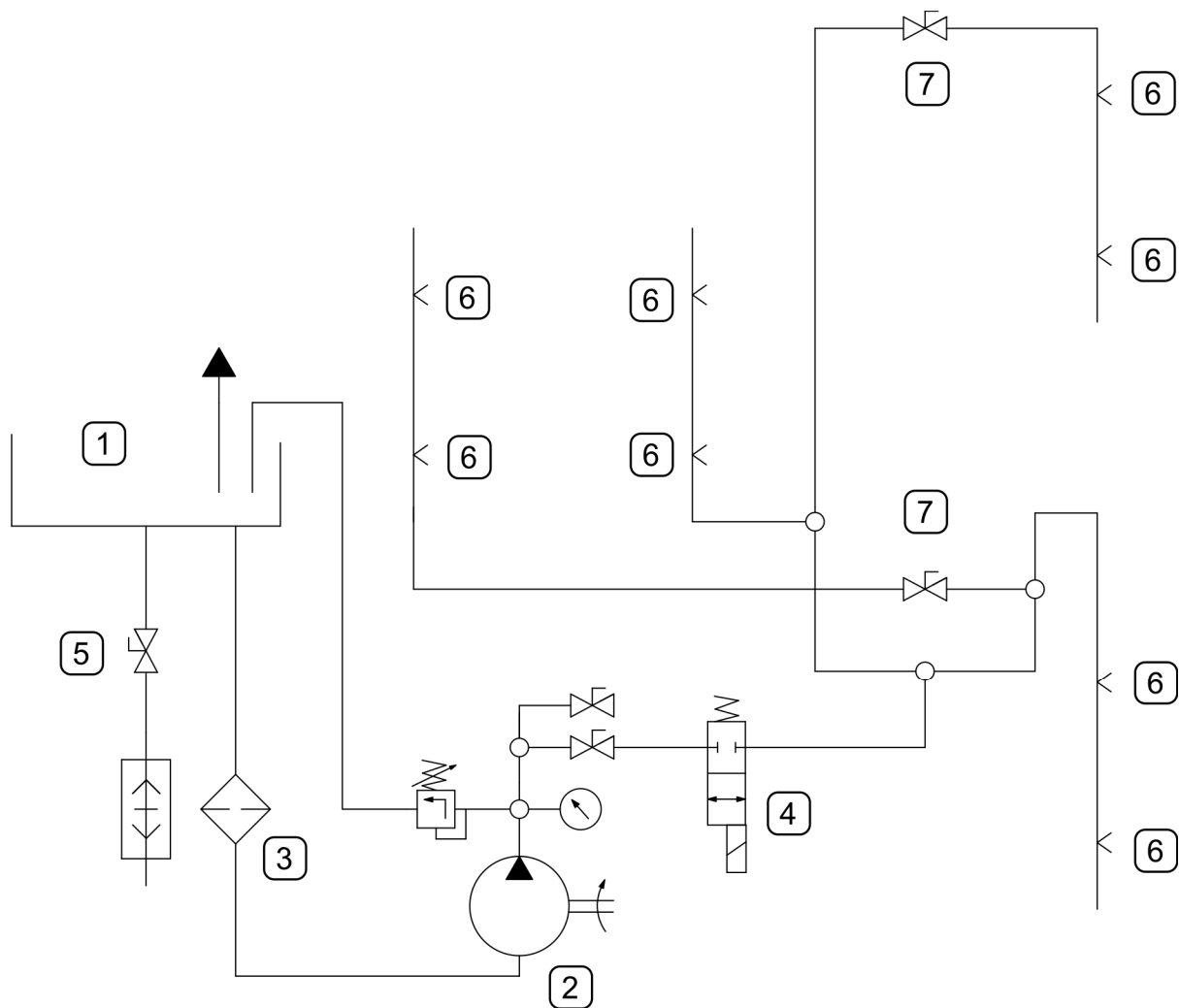

FIG. 3.8 Sprinkler system design

(1) - water tank; (2) - water pump; (3) - filter; (4) - solenoid valve; (5) - drain valve with filling connection; (6) - sprinkling nozzles; (7) - valve

3.6 ELECTRICAL SYSTEM

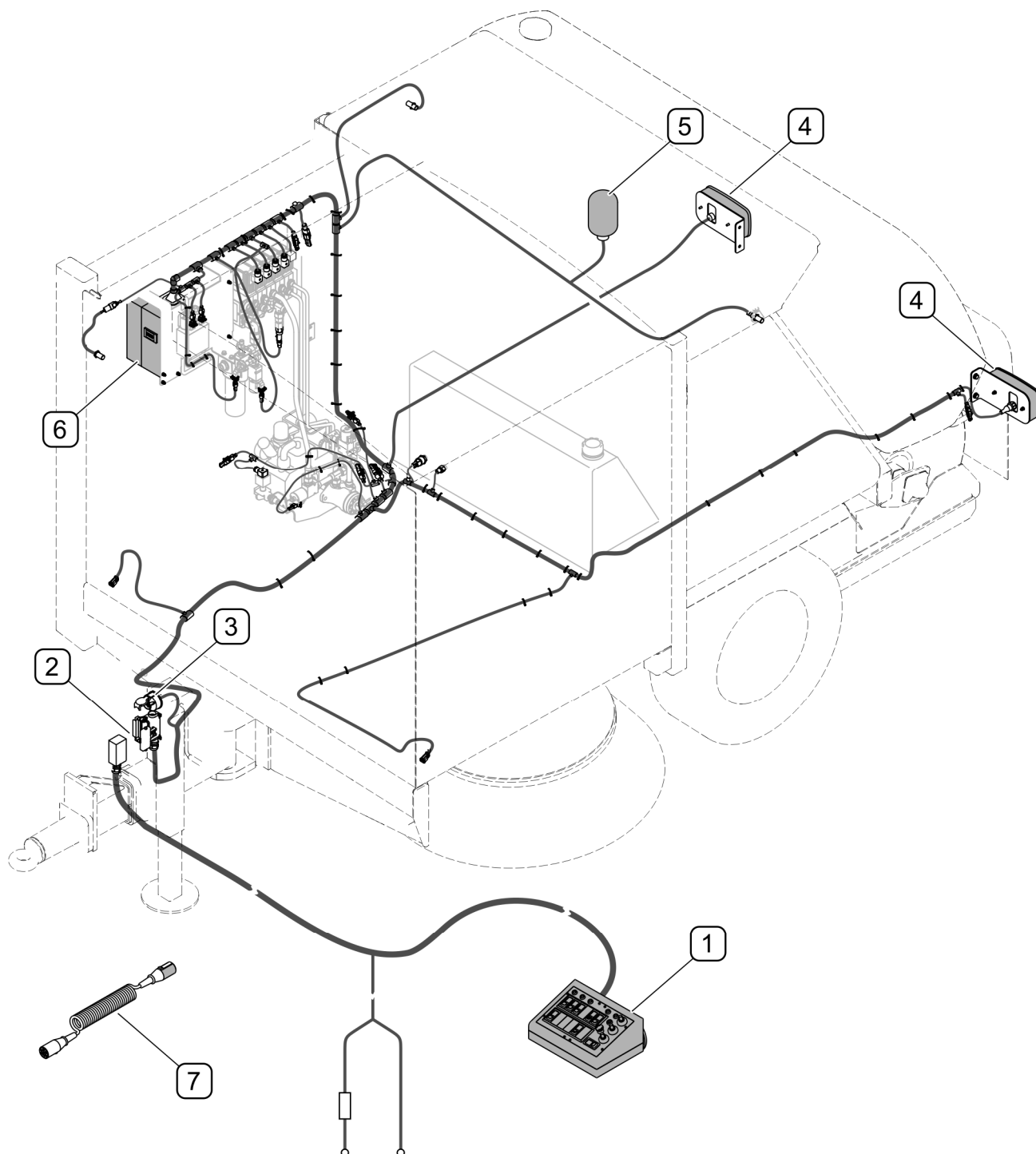

FIG. 3.9 Electrical system design

(1) - control panel; (2) - control connector; (3) - 7-pole socket; (4) - lighting system lamps;
(5) - beacon light; (6) - control unit; (7) - connection lead of 7-pole socket

3.7 SWEEP SYSTEM

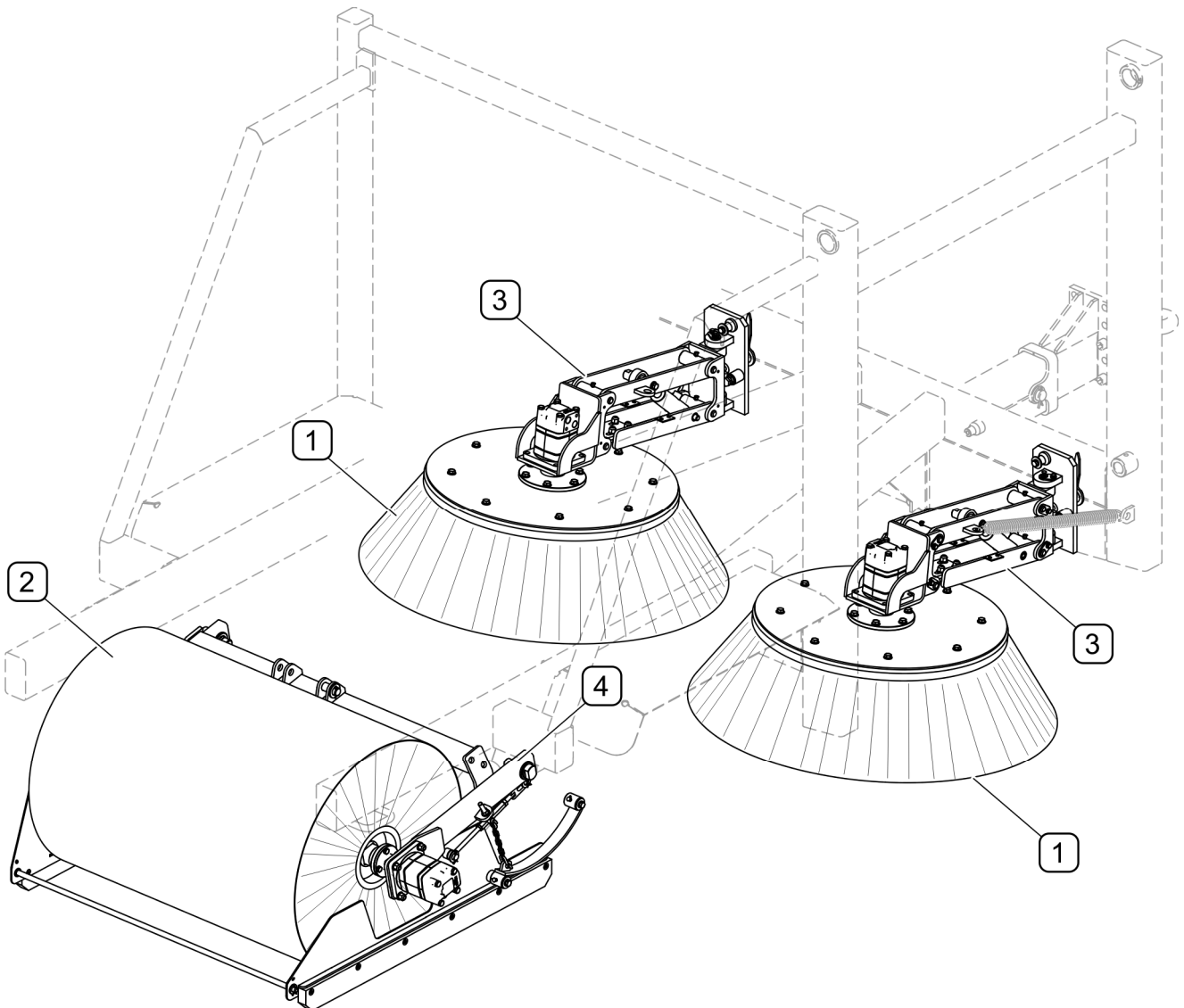

FIG. 3.10 Sweep system

(1) - disk brush; (2) - roller brush; (3) - disk brush arm; (4) - roller brush bracket

The sweep system (FIG. 3.10) consists of two disk brushes (1). The brushes direct waste to the inside of the machine. Then, roller brush (2) sweeps waste to the elevator (FIG. 3.11).

3.8 ELEVATOR AND WASTE TANK

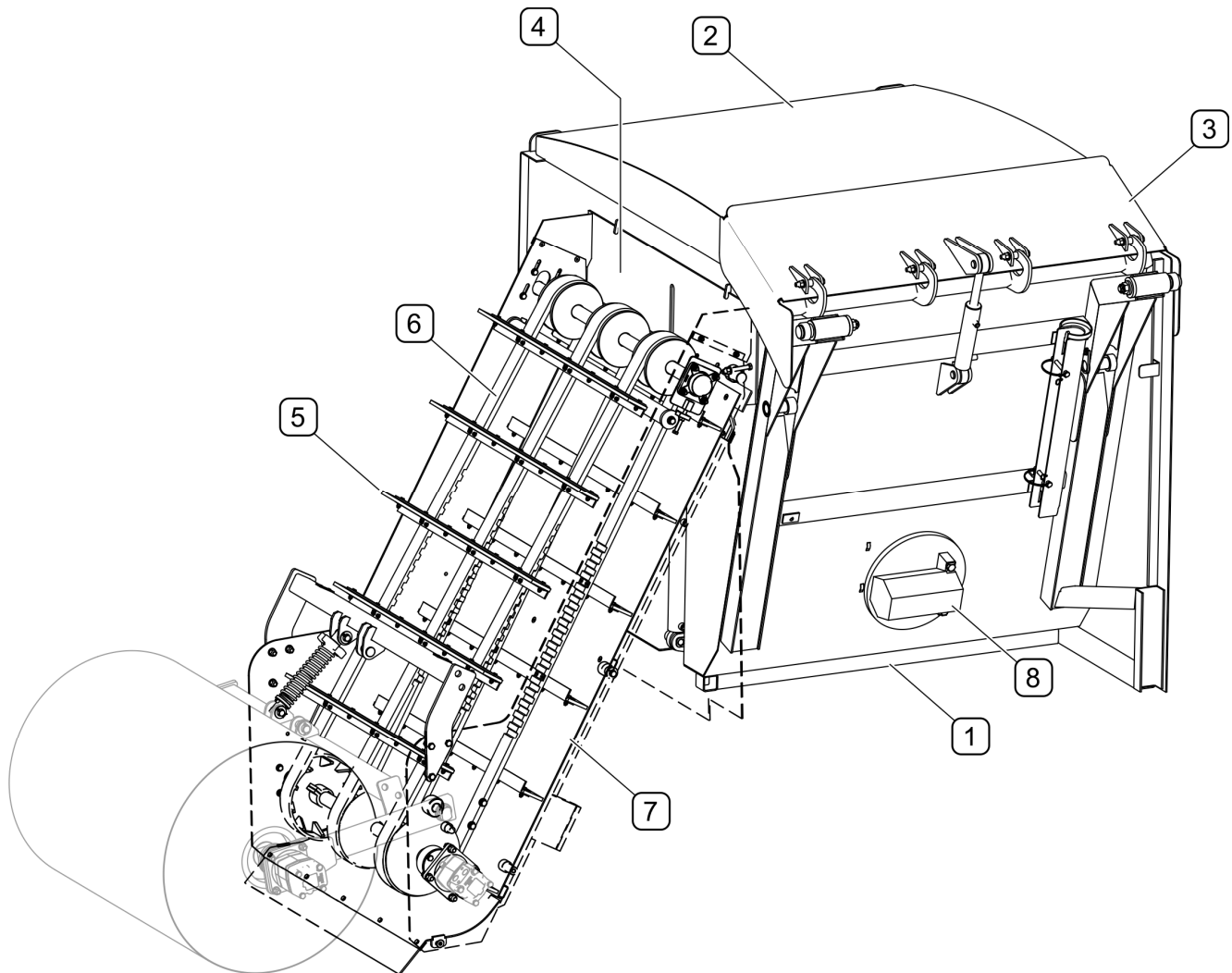

FIG. 3.11 Elevator and waste tank

(1) - waste tank; (2) - cover; (3) - gate; (4) - damper; (5) - scraper; (6) - belt; (7) - slide plate; (8) - vibrator (option)

Waste is transported by means of scrapers (5) on the elevator's slide plate (7) to waste tank (1). The waste tank is unloaded hydraulically to the right side of the machine. Optionally, the machine can be equipped with vibrator (8) that facilitates discharging waste.

SECTION

4

CORRECT USE

4.1 PREPARING FOR WORK BEFORE FIRST USE

ZMC3.0 sweeper is supplied to the user completely assembled and does not require additional mounting operations of machine sub-assemblies except the control panel that should be connected to the socket on the hitch drawbar and to the carrying vehicle's battery. The manufacturer guarantees that the machine is fully operational and has been checked according to quality control procedures and is ready for use. This does not release the user from an obligation to check the machine's condition prior to purchasing and before first use.

Prior to connecting to the tractor, machine operator must verify the sweeper's technical condition. In order to do this:

- the user must carefully read this operator's manual and observe all recommendations,
- immobilise machine with parking brake
- check technical condition of protective shields and check if they are correctly installed,
- check condition of paint coatings, traces of corrosion or mechanical damage (crushing, piercing, bending or breaking of minor elements),
- check technical condition of brushes and adjustment of machine,
- check technical condition of tyres and tyre pressure,
- check and adjust the height of drawbar to the tractor hitch,
- check level of oil in the machine's hydraulic system tank and in the hydraulic intensifier.
- Make sure that the hydraulic system valve is open (FIG. 4.8)



ATTENTION!

Non-adherence to the recommendations stated in the Operator's Manual or improper use may cause damage to the machine.

The technical condition before starting the machine must be no cause for concern.

**DANGER**

Before starting the tractor with the connected machine make sure the PTO drive is not engaged, otherwise it can lead to uncontrolled operation of the machine.

If all the above activities have been performed and there is no doubt as to the good technical condition of the sweeper, the machine should be hitched to tractor (see section *HITCHING TO TRACTOR*). After connecting the control panel and hydraulic system conduits, start the machine and confirm correctness of operation of individual systems and check tightness of the system and cylinders. In the event of incorrect operation, immediately disconnect tractor PTO drive and identify a fault. If a fault cannot be rectified or the repair could void the warranty, please contact the Manufacturer for additional clarifications.

4.2 PREPARING FOR NORMAL OPERATION

**DANGER**

Before using the machine, the user must carefully read this operator's manual.

Careless and improper use and operation of the machine, and non-compliance with the recommendations given in this operator's manual is dangerous to your health.

The machine must never be used by persons, who are not authorised to drive agricultural tractors, including children and people under the influence of alcohol or other drugs.

Before commencing work check the following:

- technical condition of tyres and tyre pressure,
- tightening of nuts fixing the wheels, drawbar,
- condition of other bolt and nut connections,
- correct operation of lights and indicators.
- operation of brake system
- level of oil in the hydraulic system tank,
- level of water in the sprinkler system tank,

**ATTENTION!**

Before using the machine always check its technical condition.
Do NOT use a malfunctioning or incomplete machine.

4.3 HITCHING TO TRACTOR

4.3.1 CONNECTING THE MACHINE WITH THE TRACTOR HITCH

**DANGER**

Prior to attempting to hitch the sweeper to the tractor, make sure that the sweeper is immobilised with parking brake.

ZMC3.0 sweeper may be hitched to a tractor or another carrying vehicle that meets the requirements contained in Table 1.1 REQUIREMENTS FOR CARRYING VEHICLE.

For optimum operation, the sweeper's frame should be positioned horizontally during operation. To do this, the machine's drawbar should be positioned properly. In order to change the height of sweeper drawbar (FIG. 4.1), change the drawbar eye (1) fixing holes. In order to change the hitch length, loosen press bolt (4), take out pin (3), slide in or slide out drawbar (2) and relock the drawbar with press bolt (4) and pin (3).

After sliding out from the guide, the hitch can be rotated in order to achieve a larger adjustment scope of the drawbar eye height.

The drawbar eye height (measured from the ground) can be changed within the range of 285 - 505 mm, by steps of 60 mm.

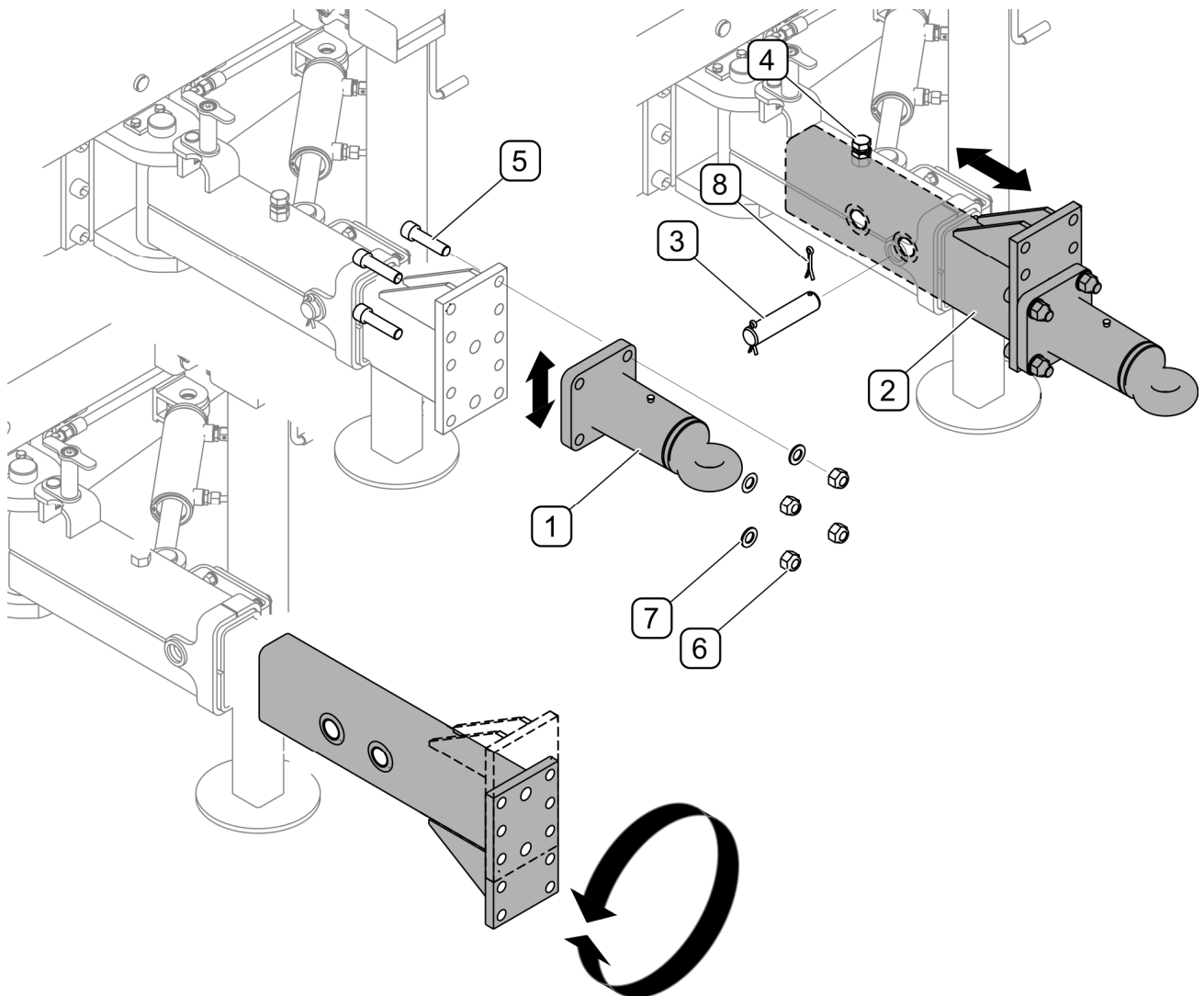

FIG. 4.1 Adjustment of sweeper hitch

(1) - drawbar eye; (2) - drawbar; (3) - pin; (4) - press bolt; (5) - M20x80 bolt; (6) - M20 nut; (7) - 20-100HV washer; (8) - 6,3x60 cotter pin

In order to attach the sweeper to tractor, proceed as follows

- using adjustable support (FIG. 4.2), set the drawbar eye at a proper height,
- While tractor is in reverse, connect drawbar eye to the tractor's hitch and check if the connection is secure,
- raise the parking stand by means of crank (1),
- turn crank (2) in order to release parking brake.



DANGER

When hitching, there must be nobody between the sweeper and the tractor.

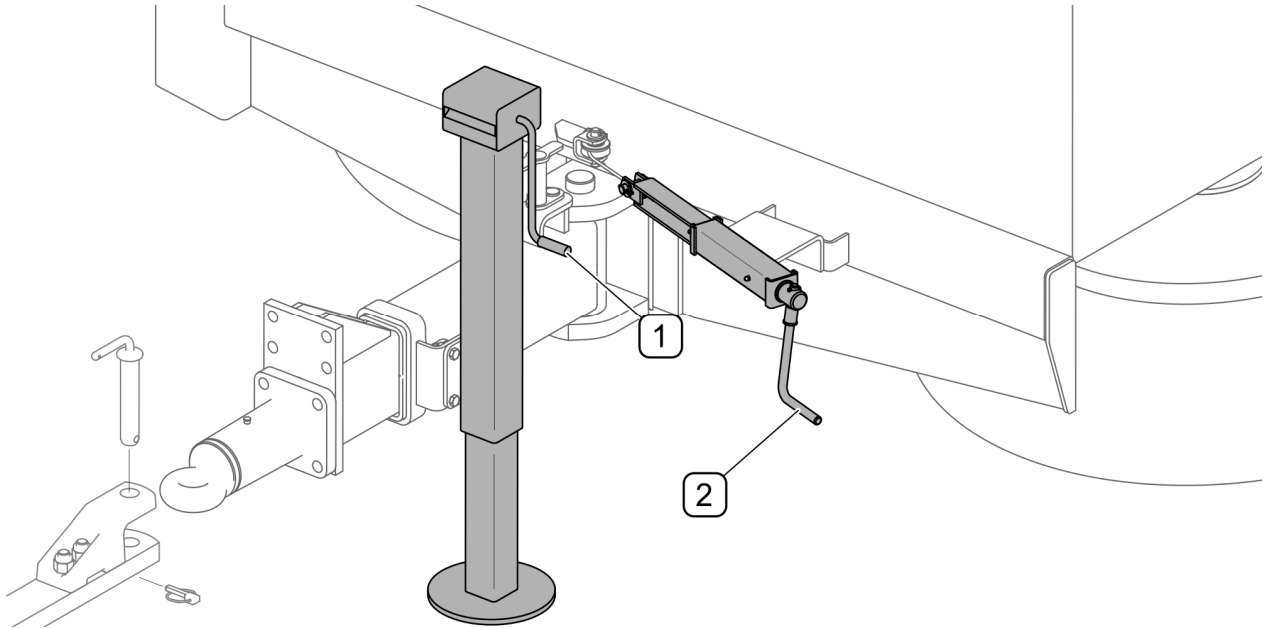

FIG. 4.2 Support and parking brake

(1) - parking stand raising/lowering crank; (2) - crank of parking brake mechanism

	DANGER
Parking stand must be maximally raised during machine operation and travel.	

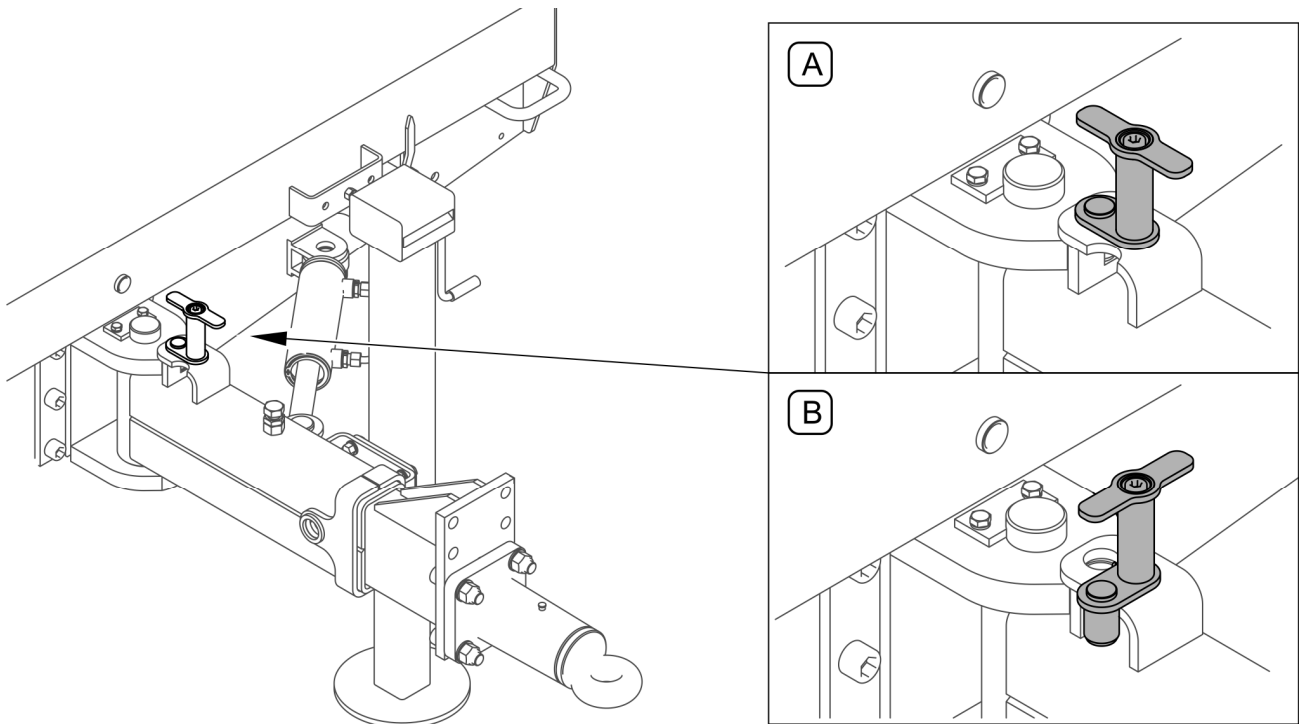

FIG. 4.3 Drawbar turning interlock

(A) - drawbar turning interlock is locked; (B) - drawbar turning interlock is unlocked

Before starting work with the sweeper, confirm that the drawbar turning interlock is unlocked (B) (FIG. 4.3). Drawbar turning interlock is used during transport or when the machine is parked.



ATTENTION!

While operating the sweeper, the drawbar turning interlock should be unlocked (B, FIG. 4.3)

4.3.2 CONNECTING ELECTRICAL SYSTEM

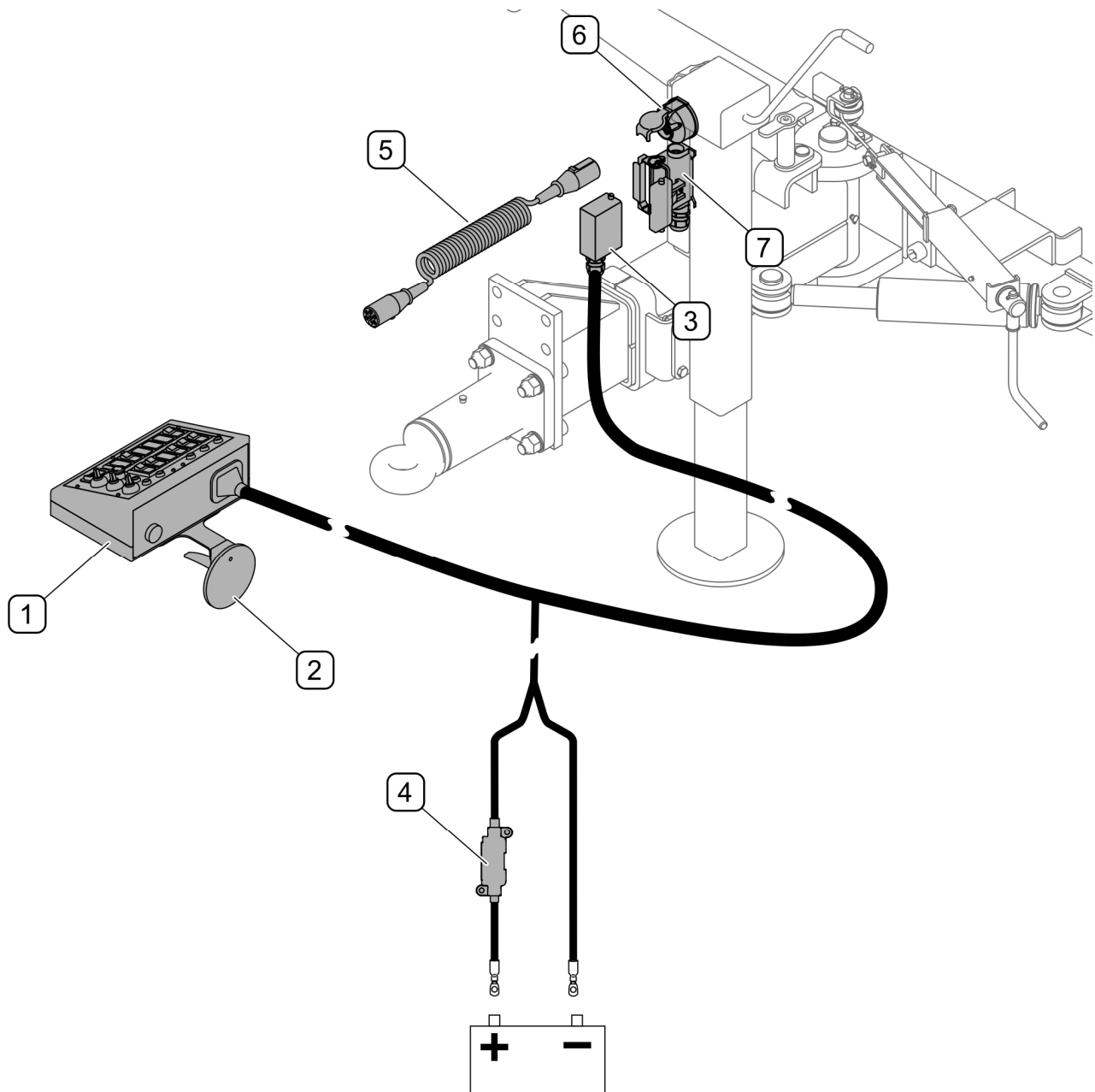



FIG. 4.4 Connecting electrical system

(1) - control panel; (2) - securing suction pad; (3) - plug; (4) - 50A fuse; (5) - connection lead; (6) - 7-pole socket; (7) - control system socket

Place the control panel (1) in the operator cab in an easily accessible place (FIG. 4.4). Control panel is equipped with vacuum cup (2) for attaching to the operator cab's windscreen. Connect red supply lead of the supply wiring harness to the positive end of the tractor's battery (+) and black supply lead to the negative battery end (-). The supply wiring harness has a 50A fuse (4) on the supply lead (+). Connect plug (3) to socket (7) on the sweeper's hitch. Connect connection lead (5) to 7-pole socket (6) of the machine and tractor.



ATTENTION!

Arrange connecting cables so as to prevent their damage during machine operation.

4.3.3 CONNECTING BRAKE SYSTEM

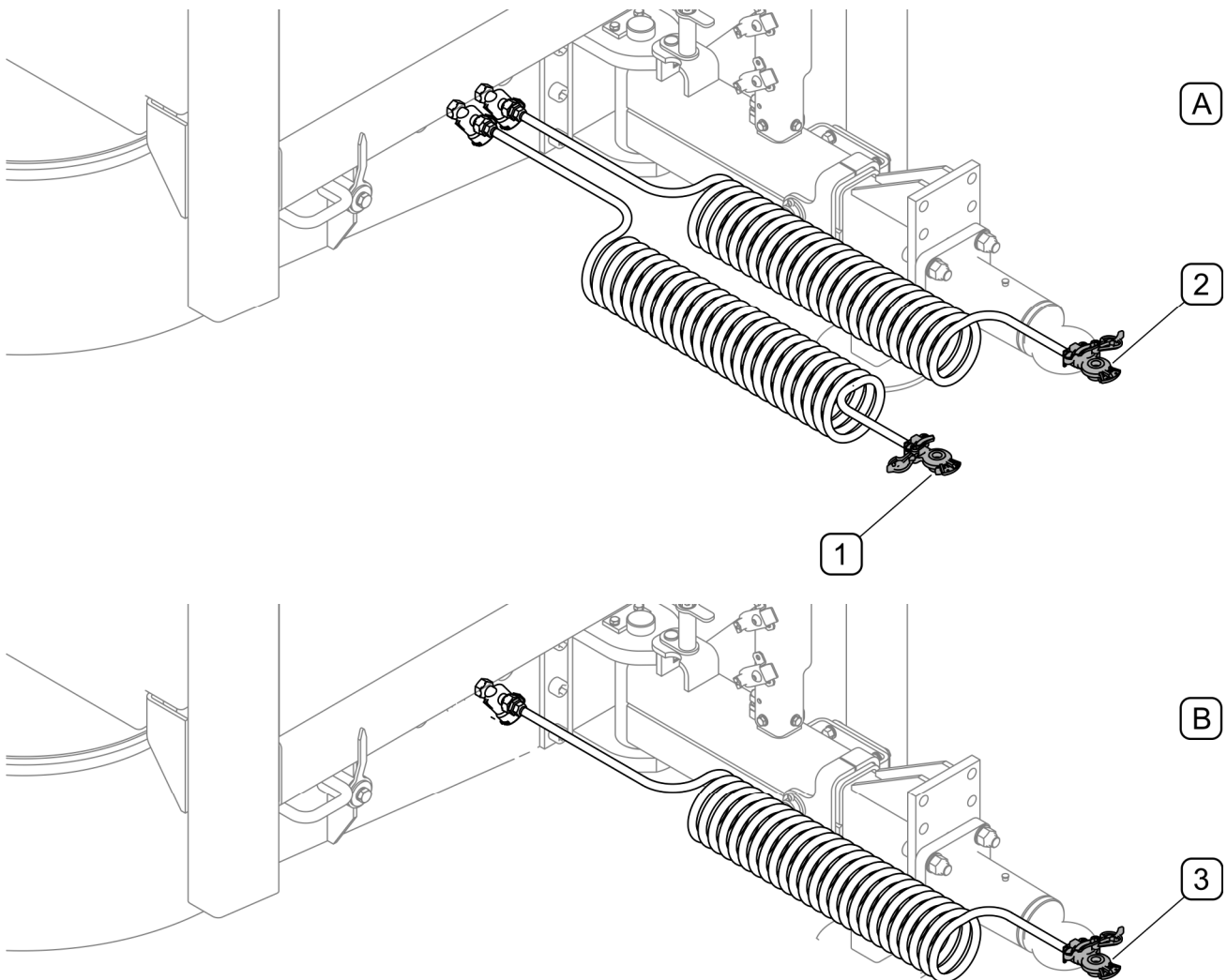

FIG. 4.5 Connection of pneumatic brake system

(A) - two conduit system; (B) - single conduit system; (1) - "yellow" connection; (2) - "red" connection; (3) - "black" connection of single conduit system

**DANGER**

Prior to connecting individual system lines the user must carefully read the carrying vehicle operator's manual and observe all Manufacturer's recommendations.

Connections and connecting conduits of pneumatic brake system (FIG. 4.5) are made from coloured plastic. The colours of these elements correspond to the colours of the connection sockets in the carrying vehicle.

**ATTENTION!**

Do NOT travel with machine, which has an unreliable brake, lighting or signalling system.

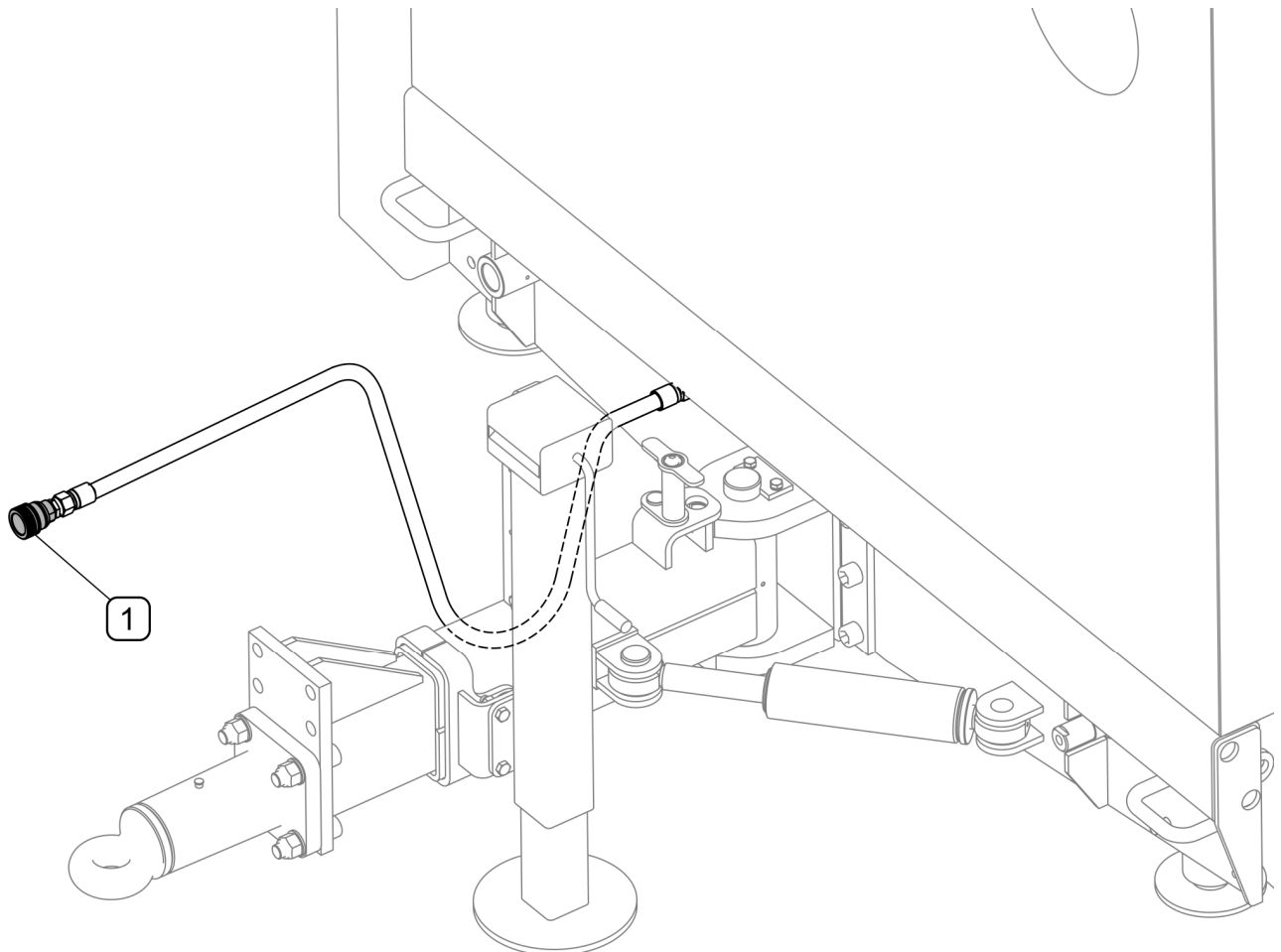

FIG. 4.6 Connecting hydraulic brake system (option)

(1) - quick coupler of hydraulic brake system

If the sweeper is equipped with hydraulic brake system, (FIG. 4.6) connect hydraulic quick coupler (1) to a suitable socket in the carrying vehicle.

4.3.4 CONNECTING THE HYDRAULIC INTENSIFIER WITH OIL PUMP



DANGER

Before connecting the hydraulic intensifier to the tractor's PTO, turn off the tractor's engine and remove the key from the ignition. Ensure that unauthorised persons do not have access to the tractor.

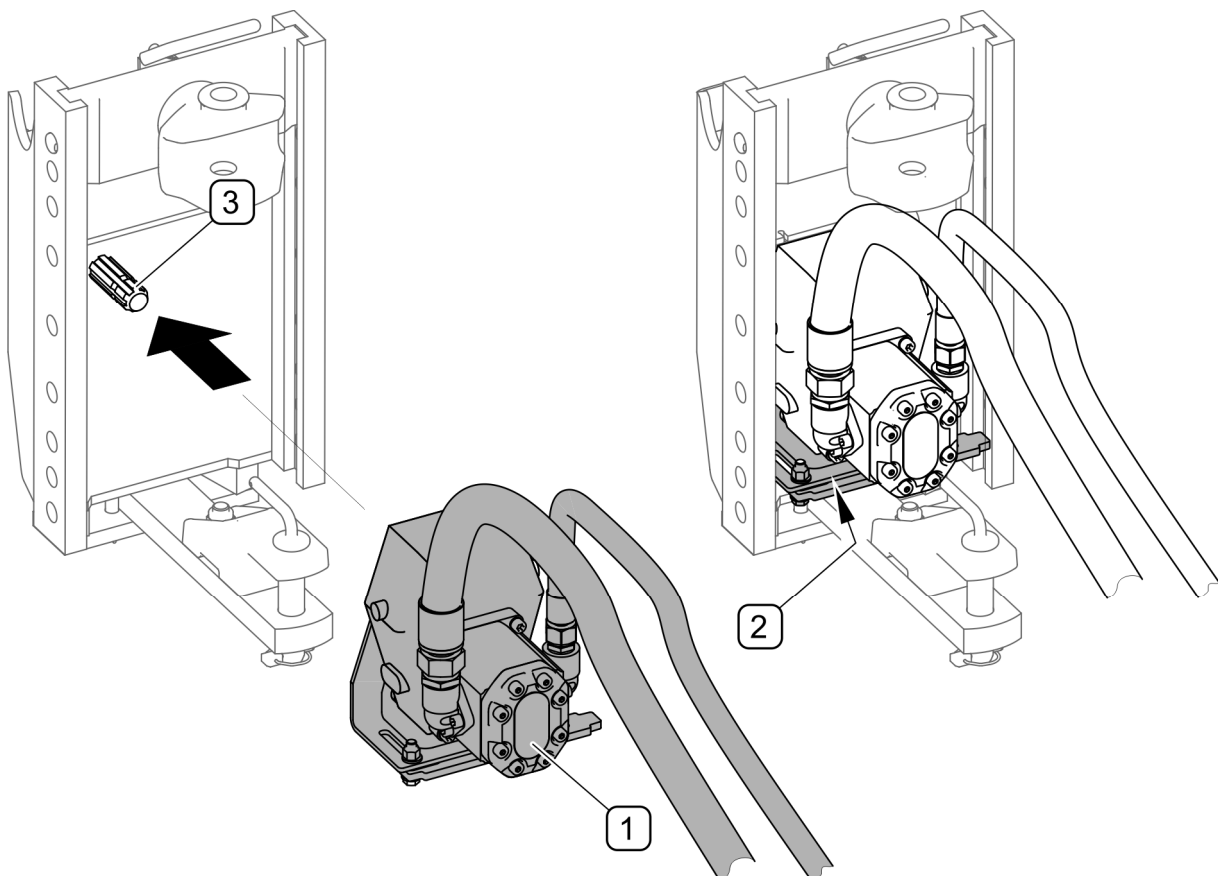

FIG. 4.7 Connection of the hydraulic intensifier to the carrying vehicle's PTO

(1) - oil pump with hydraulic intensifier; (2) - securing bracket; (3) - carrying vehicle's PTO

The hydraulic intensifier installed on the sweeper's drawbar should be dismantled. Slide hydraulic intensifier (1) with oil pump onto the carrying vehicle's PTO (3) until the locking sleeve is engaged. Immobilise the hydraulic intensifier by fixing the adjustable bracket (2) in the forks of the carrying vehicle's hitch. Due to various designs of the carrying vehicle's hitch it may be necessary to make an individual interlock securing the hydraulic intensifier against turning.

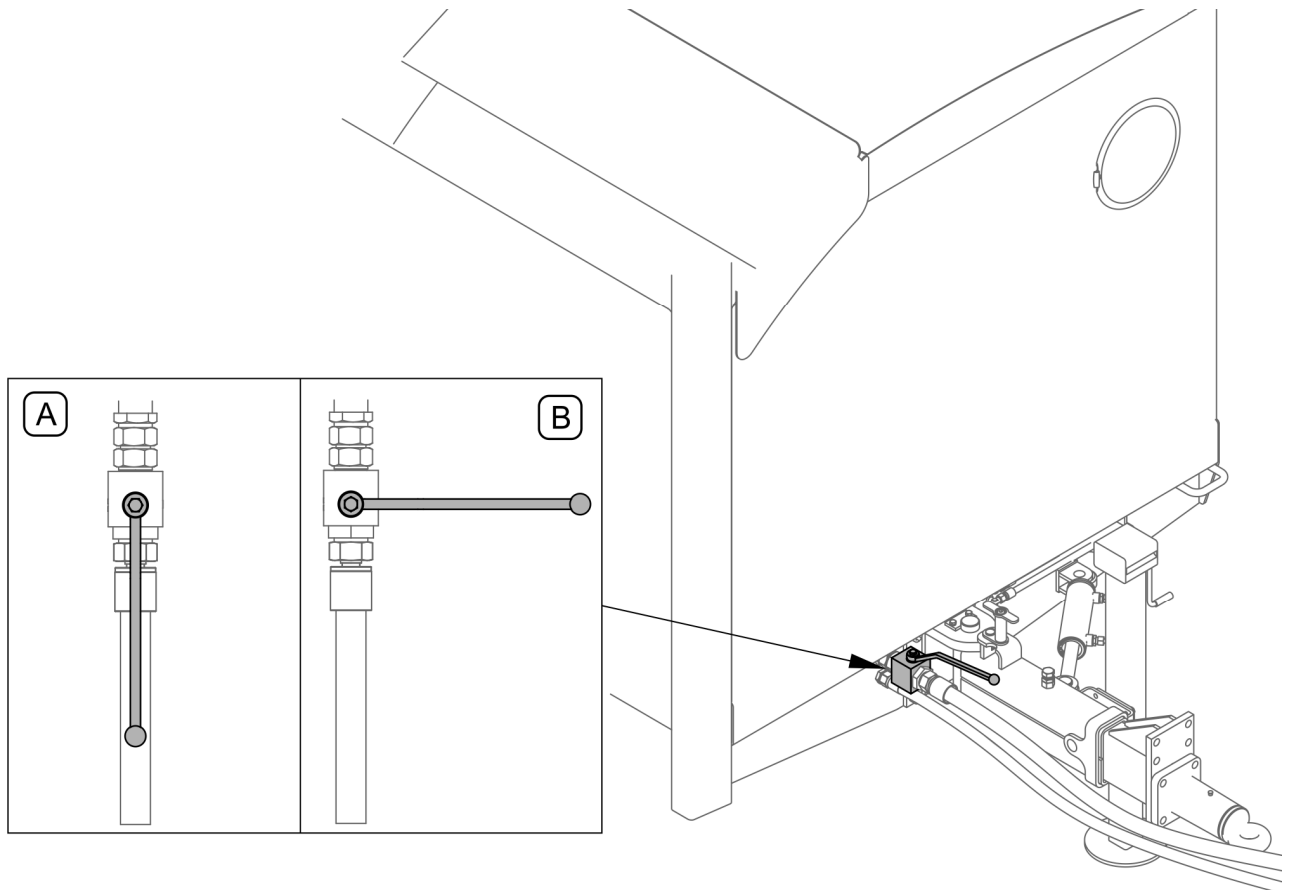

FIG. 4.8 Hydraulic system valve

(A) - open valve; (B) - closed valve

Before starting the machine make sure that the hydraulic system valve (FIG. 4.8) is open (position A). The valve should be closed only in order to replace supply pump, hydraulic intensifier or hydraulic conduits.



ATTENTION!

Arrange hydraulic lines so as to prevent their damage during operation.
During operation of the sweeper, the valve on the hydraulic supply conduit should be open (FIG. 4.8).

4.4 SWEEPER OPERATION

4.4.1 FILLING THE SPRINKLER SYSTEM TANK WITH WATER

Water tank (1) of the sprinkler system can be filled through the filler opening that is secured with plug (2) and located in the upper part of the water tank (FIG. 4.9). The tank may be also filled directly from water supply system using claw joint with valve (3). Level of water in the tank should be checked during machine operation. If there is no water in the tank, switch off the sprinkler system.

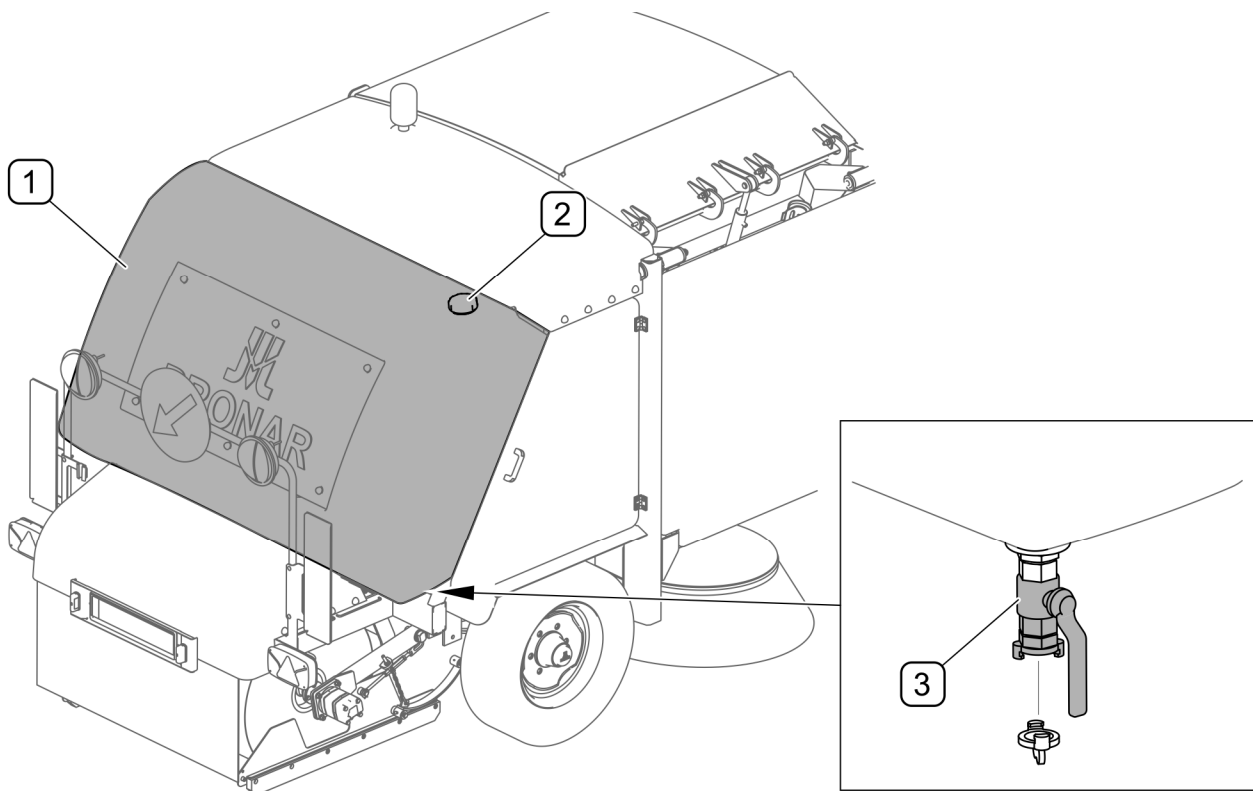

FIG. 4.9 Water tank of sprinkler system

(1) - water tank; (2) - filler plug; (3) - claw joint with valve



IMPORTANT!

If there is a risk that temperatures drop below 0°C, drain water from the tank, conduits, filter and pump.

4.4.2 CONTROL PANEL

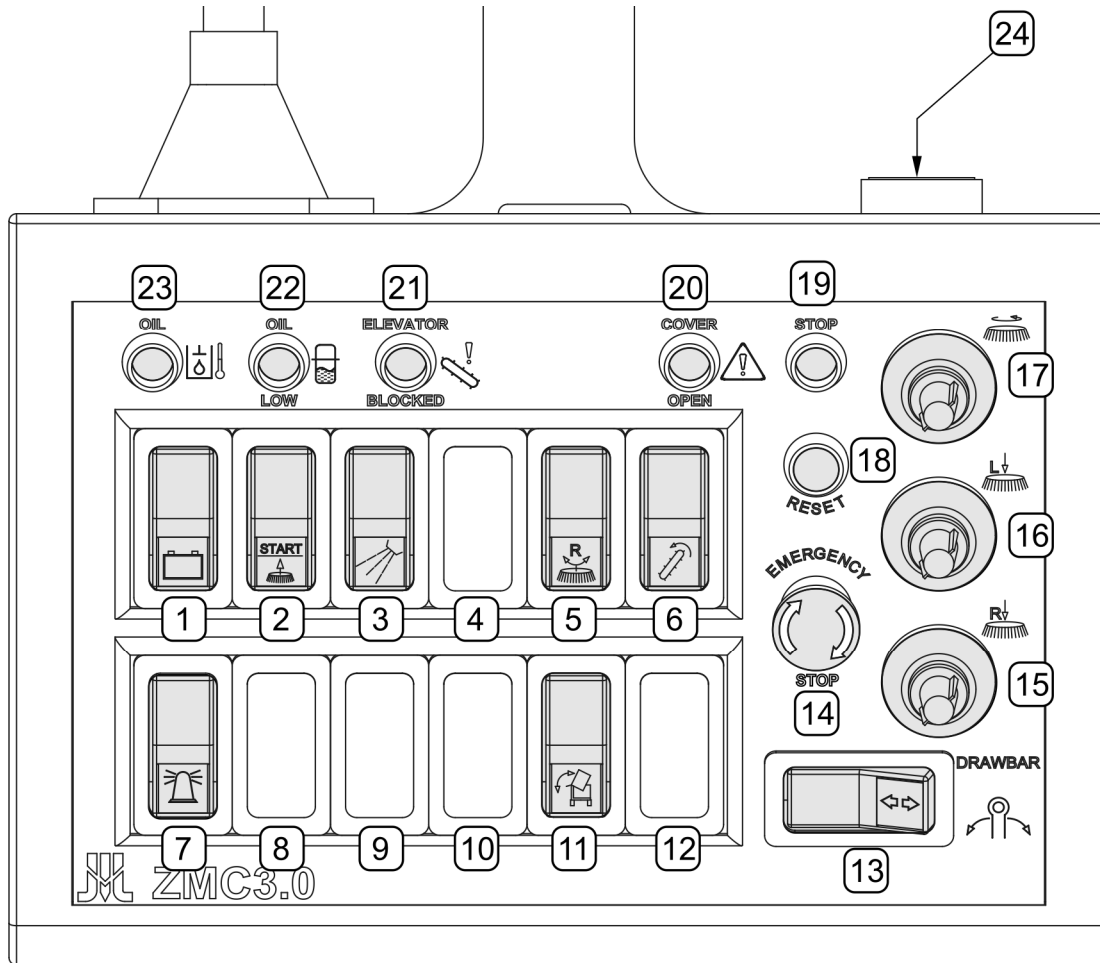





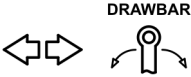



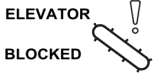



FIG. 4.10 Control panel description

TAB. 4.1 Description of control panel functions (FIG. 4.10)

ITEM	MARKING	DESCRIPTION
1		Switching on/off the control panel power supply
2	START 	Switching on and lowering the sweep unit's brushes / Switching off and raising the brushes
3		Switching on/off the sprinkler system
4	L 	Adjustment of lateral inclination of the left brush (option)
5	R 	Adjustment of lateral inclination of right brush

ITEM	MARKING	DESCRIPTION
6		Switching on/off the reverse movement of the elevator
7		Switching on/off / the warning light
8		Switching on / off the operating zone lights (option)
9,10	–	Stopper
11		Unloading (raising) / lowering the waste tank
12		Switch of the waste tank's vibrator (option)
13		Switch for changing drawbar tilting to the right / left
14	EMERGENCY STOP	Emergency STOP push-button
15		Knob for adjusting the right brush pressure
16		Knob for adjusting the left brush pressure
17		Knob for adjusting rotation speed of brushes
18	RESET	RESET push-button
19	STOP	warning light indicating activation of emergency stop push-button (14)
20		warning light that indicates opening of side shields of the machine
21		warning light that indicates blocking of elevator
22		warning light indicating low oil level
23		warning light indicating high temperature of oil
24	–	Audio signal (buzzer)

4.4.3 SWEEPING

In order to start the sweeper and start sweeping (FIG. 4.10):

- Switch on power supply of control panel by means of switch (1).
- Start the carrying vehicle's PTO and set its proper rotation speed.
- Switch on beacon light by means of switch (7), start the sweep unit by means of switch (2) and the elevator drive by means of switch (6).
- Set rotation speed of brushes by means of knob (17) and pressure of brushes on the surface by means of knobs (15) and (16).



IMPORTANT!

Excessive pressure of brushes on the surface may lead to their premature wear.



TIP

Depending on degree of contamination of surface, adjust travel speed during sweeping and set proper rotation speed of brushes.

Reduce sweeping speed if amount of contaminants to be swept increases.

Adjust pressure of brushes to force of adhesion of contaminants to the surface cleaned.



IMPORTANT!

Reversing the sweeper with brushes lowered is forbidden.

4.4.4 CONTROLLING THE SWEEPER'S TILTING DRAWBAR

The sweeper's tilting drawbar is controlled from operator cab by means of switch (1) (FIG. 4.11). The hitch is set in tilted position if sweeping has to be performed near building walls, kerbs, etc. Thanks to such hitch position, the sweeper's route can be shifted to the right with regard to the tractor's route. Thanks to adjustable sweeper's tilting drawbar, the sweeper can accurately follow the tractor, particularly when sweeping on turns, around columns, posts and benches.



IMPORTANT!

Controlling the sweeper's tilting drawbar is possible if the drawbar is unlocked (B, FIG. 4.11)

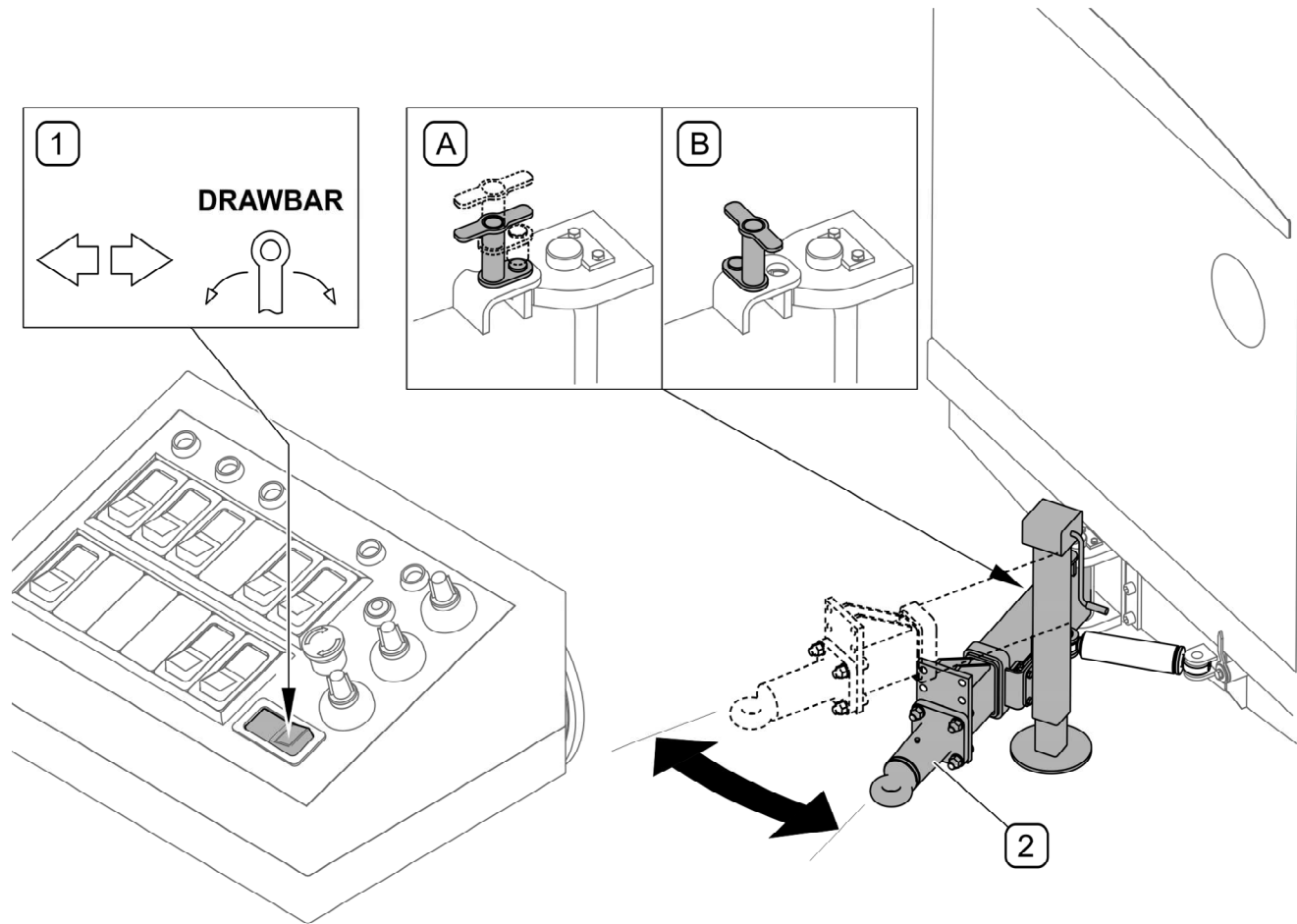



FIG. 4.11 Controlling the sweeper's tilting drawbar

(1) - drawbar control switch; (2) - tilting drawbar; (A) - drawbar is locked; (B) - drawbar is unlocked

4.4.5 OPERATION WITH ACTIVATED SPRINKLER SYSTEM

In case of intensive dusting, switch on the sprinkler system by means of switch (1) on the control panel (FIG. 4.12). The sprinkler system can be switched on after activation of the sweep unit. It is possible to switch off some of the sprinklers by means of valves (2).



IMPORTANT!

Do not switch on the sprinkler system if the water tank is empty. Operation of the sprinkler system without water in the tank may lead to damage to the water pump.

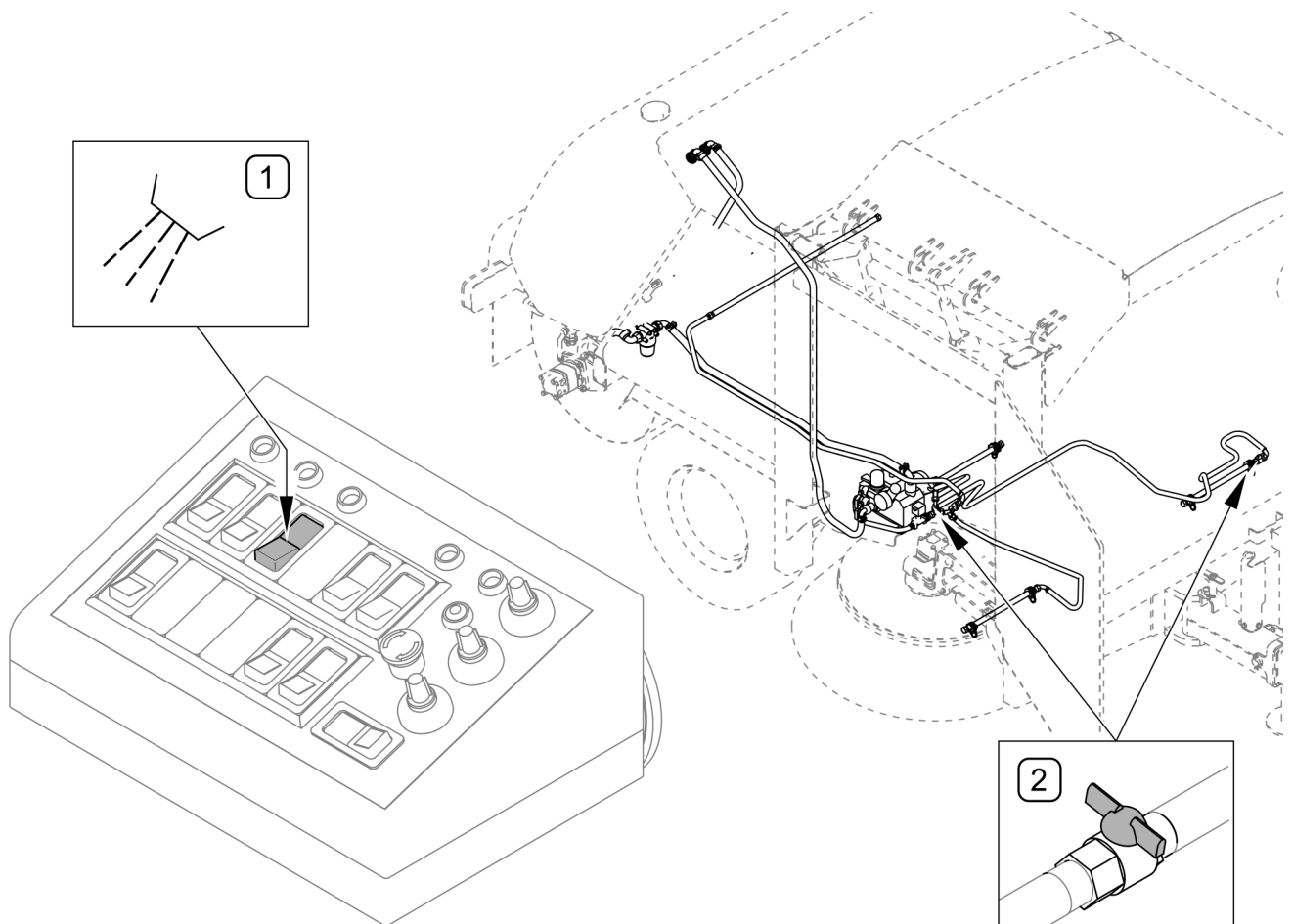

FIG. 4.12 Sprinkler system control

(1) - sprinkler system switch; (2) - valve

4.4.6 EMPTYING THE WASTE TANK



DANGER

Do NOT stand under raised tank during machine operation.

Switch off the machine and install service safety devices before cleaning or inspecting the raised waste tank.

It is recommended that water collected inside the waste tank should be drained before unloading waste. Water is drained from the waste tank through the valve (FIG. 4.13) on the bottom of the waste tank, on the left side of the machine. If water is not drained after opening the valve, confirm that the valve is not blocked.

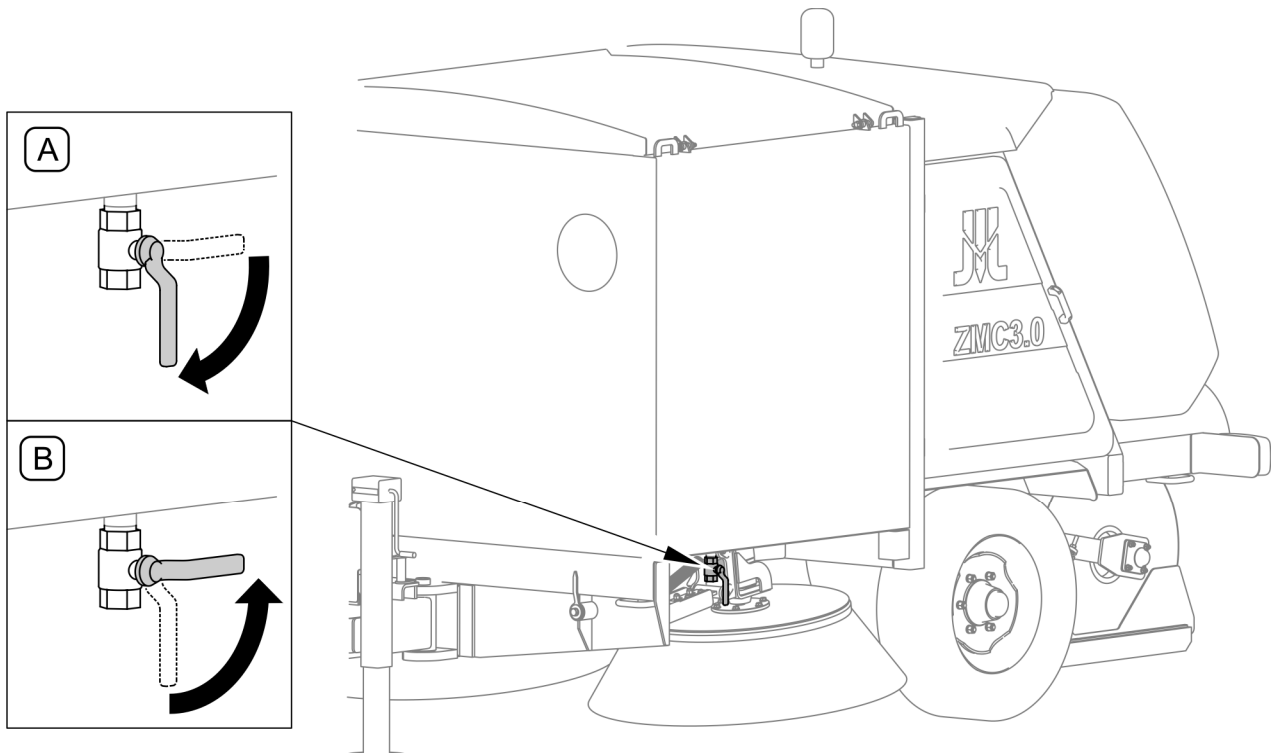

FIG. 4.13 Water drain valve in the waste tank

(A) - open drain valve; (B) - closed drain valve

Waste collected by the sweeper can be unloaded directly onto trailer's load box. The waste tank may be unloaded only when tractor is completely stationary. Raising and lowering of waste tank (1) is activated by means of switch (3) (FIG. 4.14) on the control panel.

While unloading the waste tank (FIG. 4.14), hydraulic supports (2) are lowered and warning audio signal is emitted. In order to facilitate discharging waste from the tank, the vibrator (option) can be activated by means of switch (4) on the control panel. After unloading waste, switch the vibrator off. After lowering the waste tank, make sure that hydraulic supports (2) are raised.



DANGER

Keep a safe distance from overhead electric power lines during tank unloading.

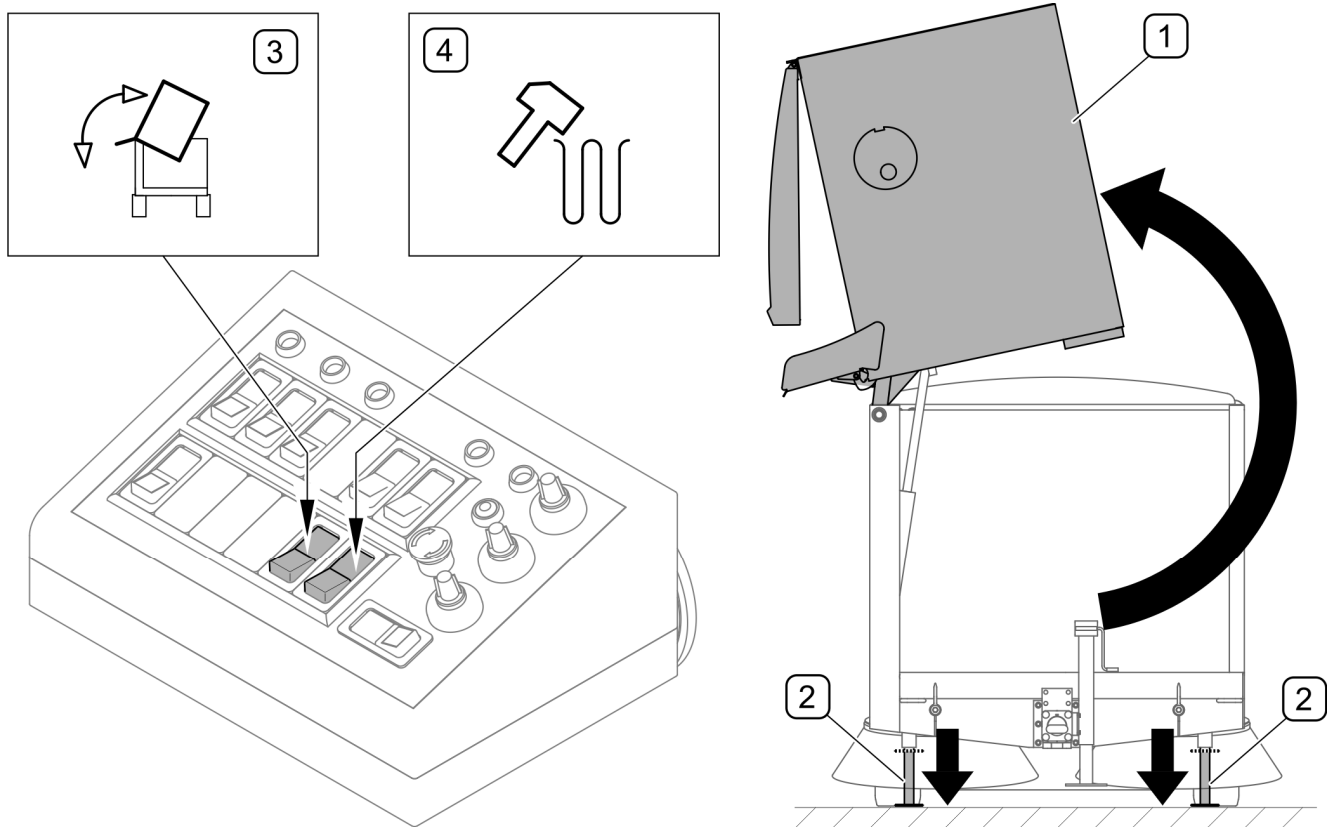

FIG. 4.14 Emptying the waste tank

(1) - waste tank; (2) - hydraulic supports; (3) - switch for unloading / lowering the waste tank;
 (4) - waste tank vibrator switch (option)

4.5 DRIVING ON PUBLIC ROADS

When driving on public roads, respect the road traffic regulations, exercise caution and prudence. If sweeping with the sweeper is done near pavements special attention should be paid to the bystanders likely to be near the working machine. Listed below are the key guidelines for driving the tractor and trailer combination.

- Make sure that the sweeper is correctly attached to the tractor and tractor's hitch is properly secured.
- Before moving off make sure that there are no bystanders, especially children, near the machine or the tractor. Take care that the driver has sufficient visibility.
- Permissible transport speed and maximum speed allowed by road traffic law must not be exceeded. The towing speed should be adapted to the current road conditions, load carried by the machine, road surface conditions and other relevant conditions.

- While operating the sweeper, turn the orange beacon light (included in the machine equipment).
- Avoid ruts, depressions, ditches or driving on roadside slopes. Driving across such obstacles could cause the machine or the tractor to suddenly tilt. Driving near ditches or canals is dangerous as there is a risk of the wheels sliding down the slope or the slope collapsing.
- During transport travel, the sweeper's tilting drawbar should be set straight and locked in this position.
- When driving, avoid sharp turns especially on slopes.
- Please note that the braking distance of tractor and sweeper combination is substantially increased at higher speeds and loads carried in the sweeper.
- Speed must be sufficiently reduced before making a turn or driving on an uneven road or a slope.
- Lower the waste tank after emptying. Do NOT travel with raised waste tank.
- When not connected to the tractor, the sweeper must be immobilised using parking brake and possibly also with chocks or other objects without sharp edges placed under the front and back wheels. Do NOT leave unsecured machine. In the event of machine malfunction, pull over on the hard shoulder avoiding any risk to other road users and position reflective warning triangle according to traffic regulations.
- While driving on public roads the sweeper must be fitted with a certified or authorised reflective warning triangle. When driving, comply with all road traffic regulations, indicate an intention to turn using indicator lamps, keep all road lights and indicator lights clean at all times and ensure they are in good condition. Any damaged or lost lamps or indicator lights must be immediately repaired or replaced.
- Reversing the sweeper with brushes lowered is forbidden.

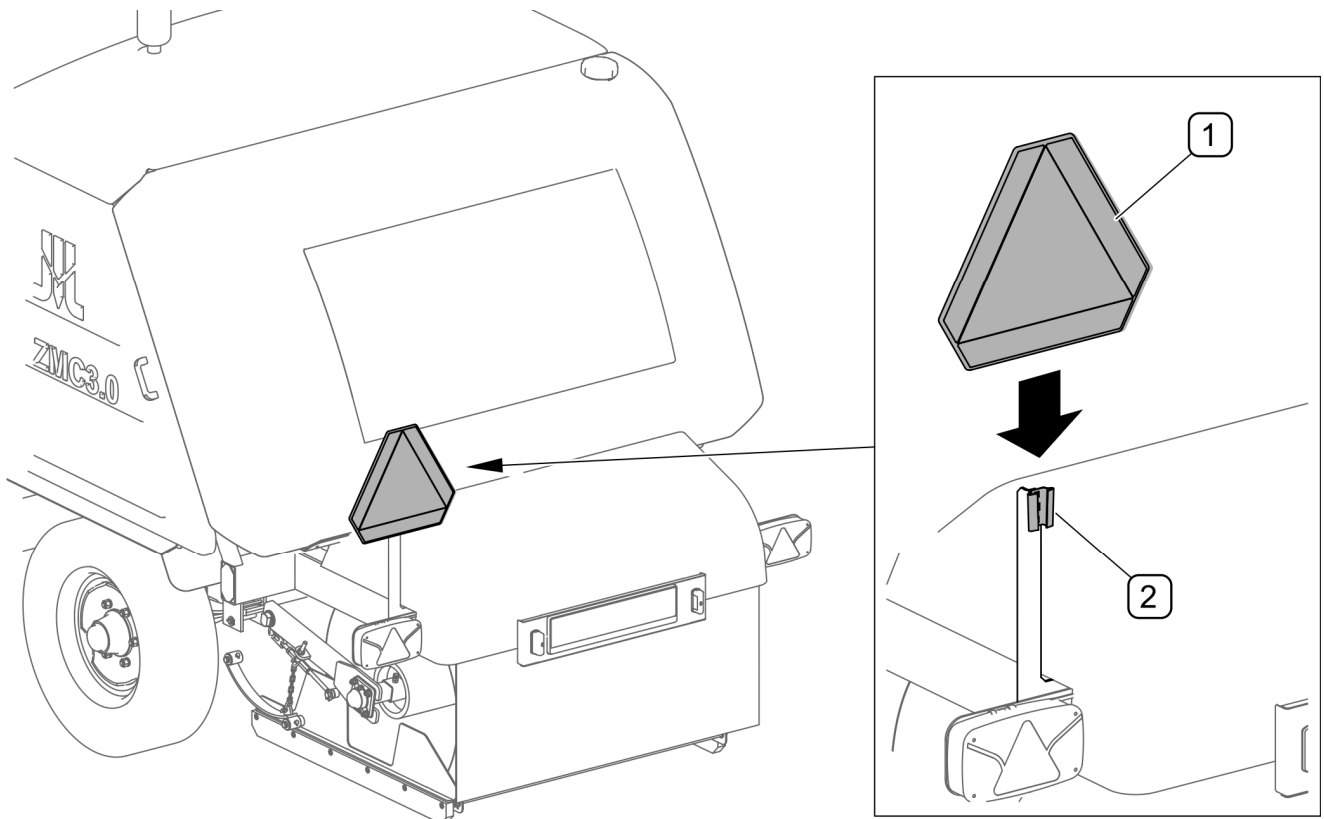

FIG. 4.15 **Warning sign installation**

(1) - slow-moving vehicle warning sign (not included in the machine equipment); (2) - bracket

While driving on public roads, the machine should be marked with slow-moving vehicle warning sign (1) placed on the rear of the machine (FIG. 4.15) The warning sign is installed in special bracket (2) located at the rear on the left side of the machine.



IMPORTANT!

Before starting work with the sweeper on public roads, make sure that the signalling and lighting systems of the carrying vehicle and the machine are in working order.

Optionally, the sweeper can be equipped with the beam with warning lights, clearance boards and C9/C10 mandatory sign installed at the rear of the machine.

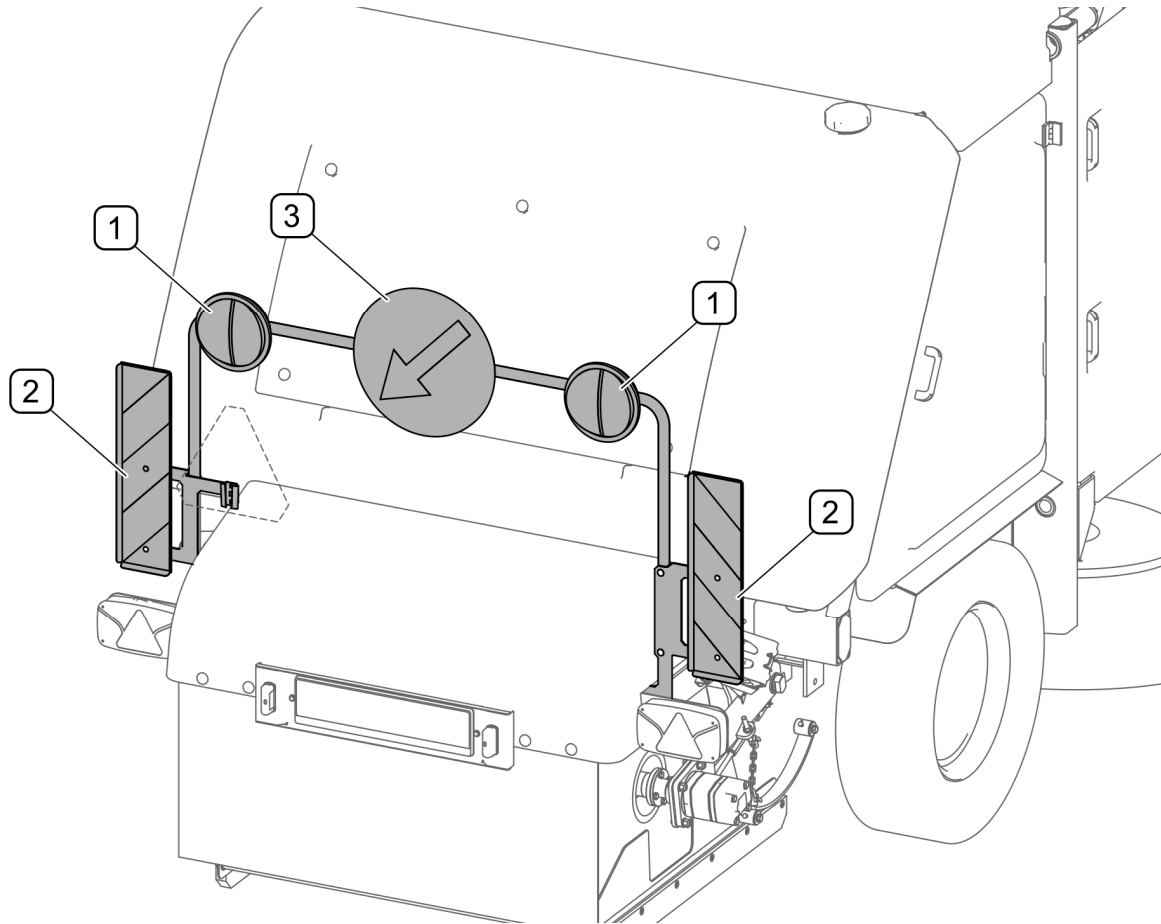

FIG. 4.16 Additional warning lights and mandatory sign (option)

(1) - warning lights; (2) - clearance boards; (3) - C9/C10 mandatory sign



IMPORTANT!

When driving on public roads, comply with the road traffic regulations.

4.6 DISCONNECTING FROM TRACTOR

In order to disconnect the sweeper from the tractor (FIG. 4.17), proceed as follows:

- Once the tractor is stopped, disengage PTO drive.
- Switch off all functions activated on the sweeper's control panel.
- Immobilise the machine with parking brake (1).
- Disconnect control panel lead and lighting system lead.
- Disconnect pneumatic socket plugs from the tractor and place them on brackets (2) on the sweeper's drawbar.

- Disconnect the quick coupler of hydraulic brake system from the carrying vehicle and place it on the bracket located on the sweeper's drawbar (*in sweepers with hydraulic brake system*)
- Disconnect the hydraulic intensifier and place it on the bracket (3) near the sweeper's drawbar.
- lower the parking stand (4).
- Disconnect the sweeper's drawbar from the tractor hitch and move the tractor forwards.



DANGER

Do not disconnect the sweeper from the tractor if the waste tank is raised!

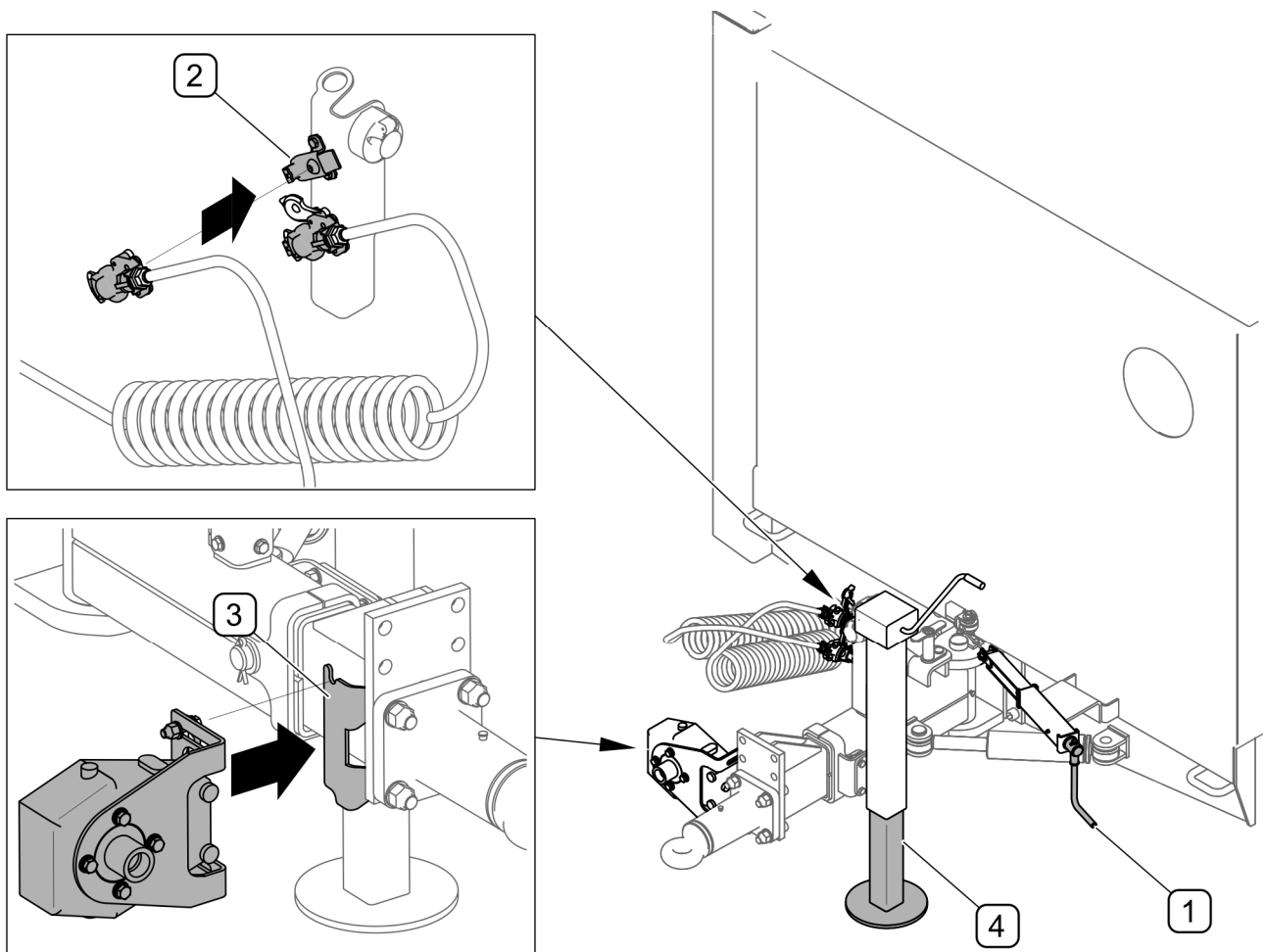

FIG. 4.17 **Disconnecting sweeper from tractor**

(1) - parking brake; (2) - brackets of pneumatic socket plugs; (3) - hydraulic intensifier bracket; (4) - parking stand

4.7 PROPER USE AND MAINTENANCE OF TYRES

- When working with tyres, the machine should be secured against rolling by placing chocks under the wheels. Wheels can be taken off the sweeper axle only when the sweeper's waste tank is empty.
- Repair work on the wheels or tyres should be carried out by persons trained and entitled to do so. This work should be carried out using appropriate tools.
- After removing a wheel, always check how firmly the nuts are screwed in. Individual checks should be made after the first use, after the first journey with a load and then every 6 months. In the event of intensive work, check the nut tightening at least every 100 km. The above actions should be repeated individually if a wheel has been removed from the wheel axle.
- Regularly check pressure in tyres (especially if machine is not used for a longer period).
- Tyres pressure should be also checked after the whole day of intensive work. Please note that higher temperatures could raise tyre pressure by as much as 1 bar. At high temperatures and pressure, reduce load or speed.
- Do not release air from warm tyres to adjust the pressure or the tyres will be underinflated when temperatures return to normal.
- Protect tyre valves using suitable caps to avoid soiling.
- Do not exceed the maximum transport speed.
- Avoid potholes, sudden manoeuvres or high speeds when turning.



TIP

Tire type: 235/75R17.5 KORMORAN T, TL, 143/141 J, TL.

Recommended tire pressure: 7 ±1 bar.

SECTION

5

MAINTENANCE

5.1 SERVICE INTERLOCK

Service interlock (FIG. 5.1) are used to block the waste tank in raised position. Use service interlock during maintenance, servicing or repair of the machine.

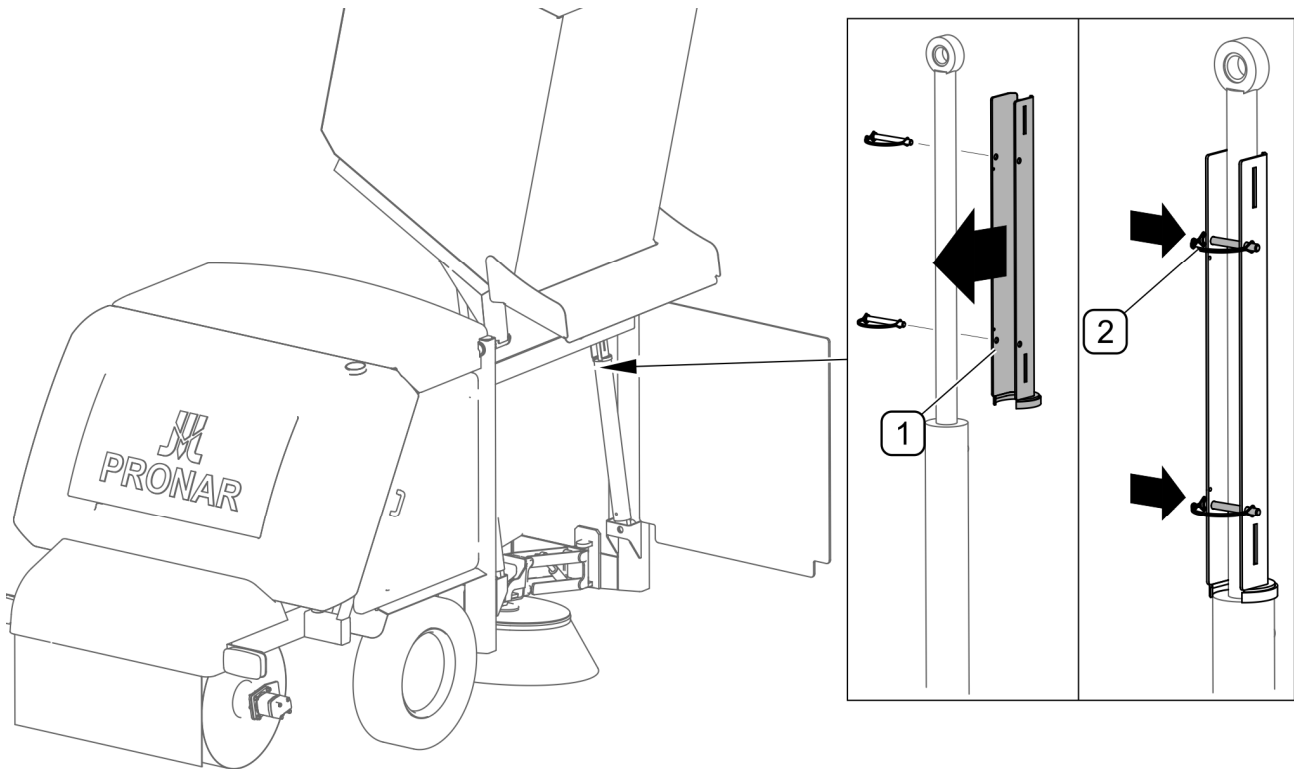

FIG. 5.1 Service interlock

(1) - service interlock; (2) - locking cotter pin

Service interlock is included in the sweeper's equipment and is attached to the waste tank, on the right side of the machine.

In order to use the service interlock (FIG. 5.1):

- raise the waste tank maximally, immobilise the sweeper,
- install interlocks (1) on the waste tank raising cylinder,
- Secure the interlock with cotter pins (2).



DANGER

Switch off the machine and install service interlocks before performing any maintenance, adjustment and repair activities near the raised waste tank.

5.2 ADJUSTMENT OF SWEEP UNIT AND ELEVATOR

5.2.1 ADJUSTMENT OF DISK BRUSHES



DANGER

Prior to adjustment work, switch off the sweeper completely, switch off the tractor engine, remove key from ignition and engage parking brake in order to ensure safety.

Correctly positioned brush should touch the surface only with a section of its circumference in such a manner as to ensure that waste is directed to the inside of the sweeper. Shaded areas on diagram (FIG. 5.2) indicate sections of correctly set brushes which touch the surface. Adjustment of longitudinal and lateral inclination have influence on proper brush setting. Make certain that waste is not swept outside the machine. If necessary, adjust the sweep unit.

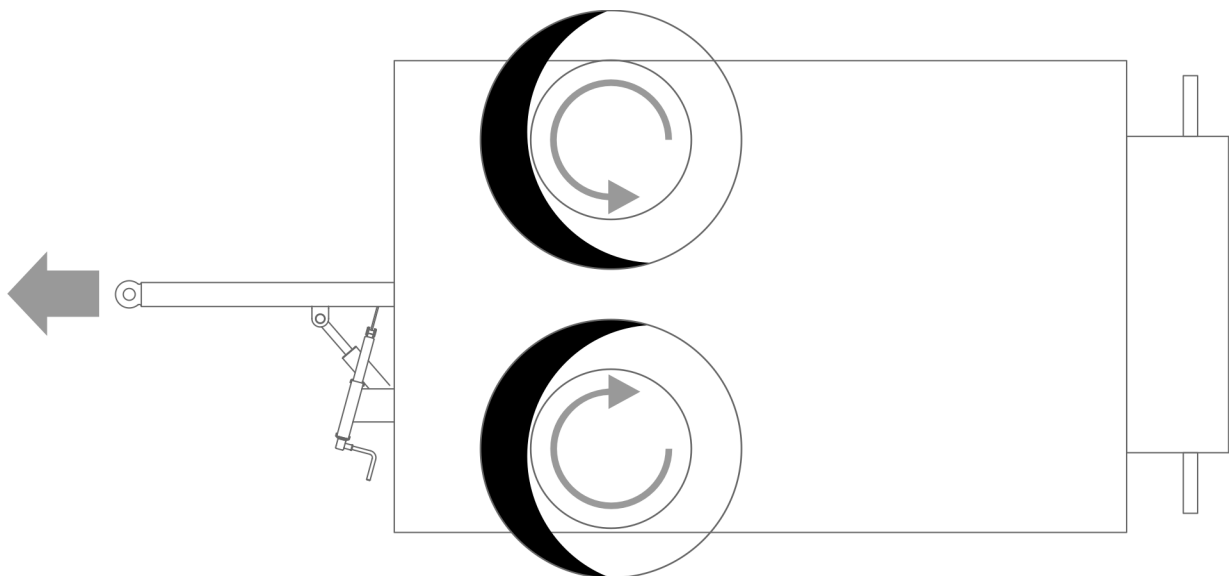

FIG. 5.2 Diagram showing arrangement of disk brushes

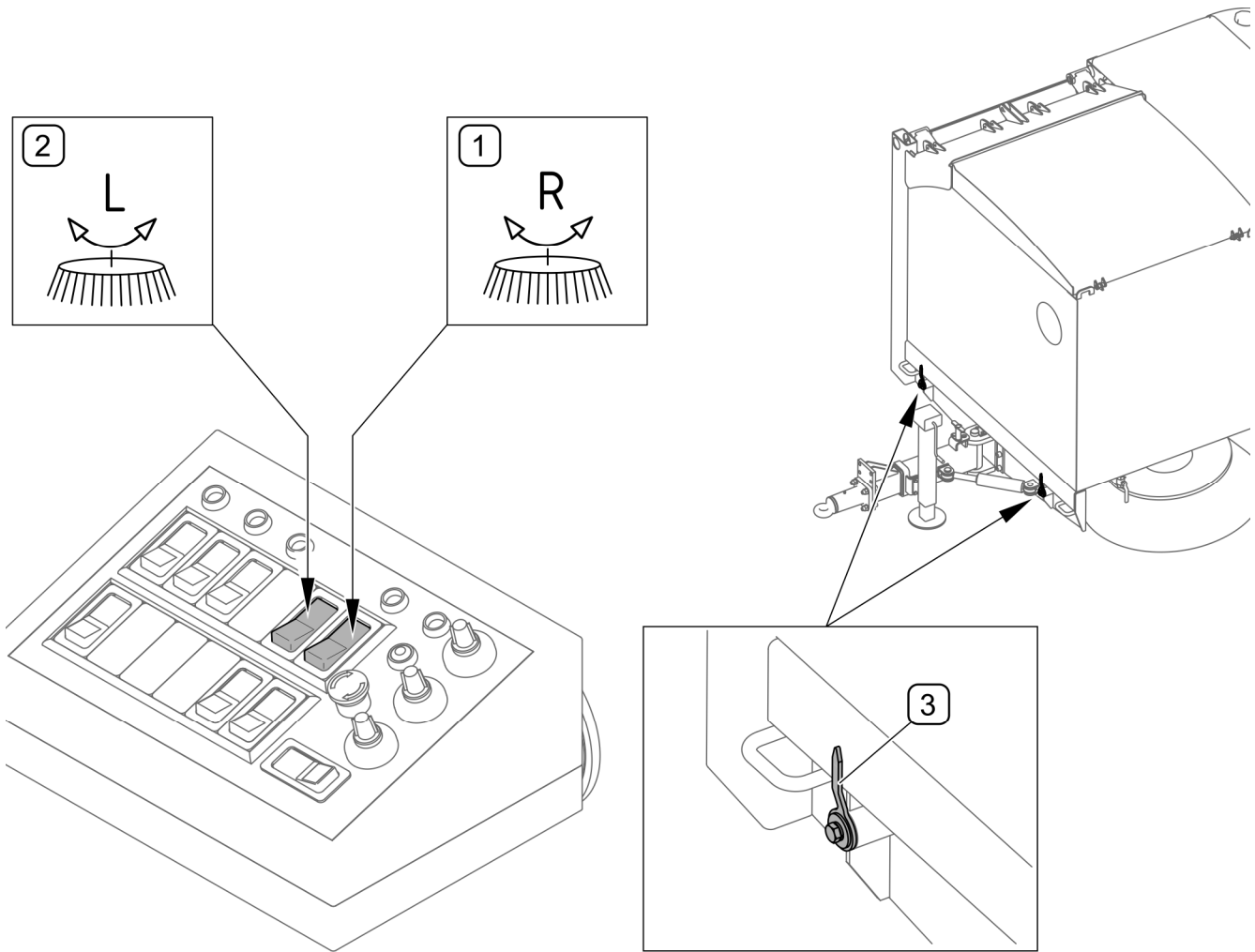

FIG. 5.3 Hydraulic adjustment of lateral inclination of brushes

(1) - control of right brush tilting; (2) - control of left brush tilting (option); (3) - indicator of lateral inclination of brushes

Adjustment of lateral inclination of the right brush and left brush (option) is carried out from operator cab by means of control panel (FIG. 5.3). Inclination of the right brush is changed by means of push-button (1). In the sweepers equipped with hydraulic adjustment of the left brush (option), the brush is inclined laterally by means of push-button (2) on the control panel. Indicators (3) located in the front section of the machine frame show current lateral inclination of brushes.

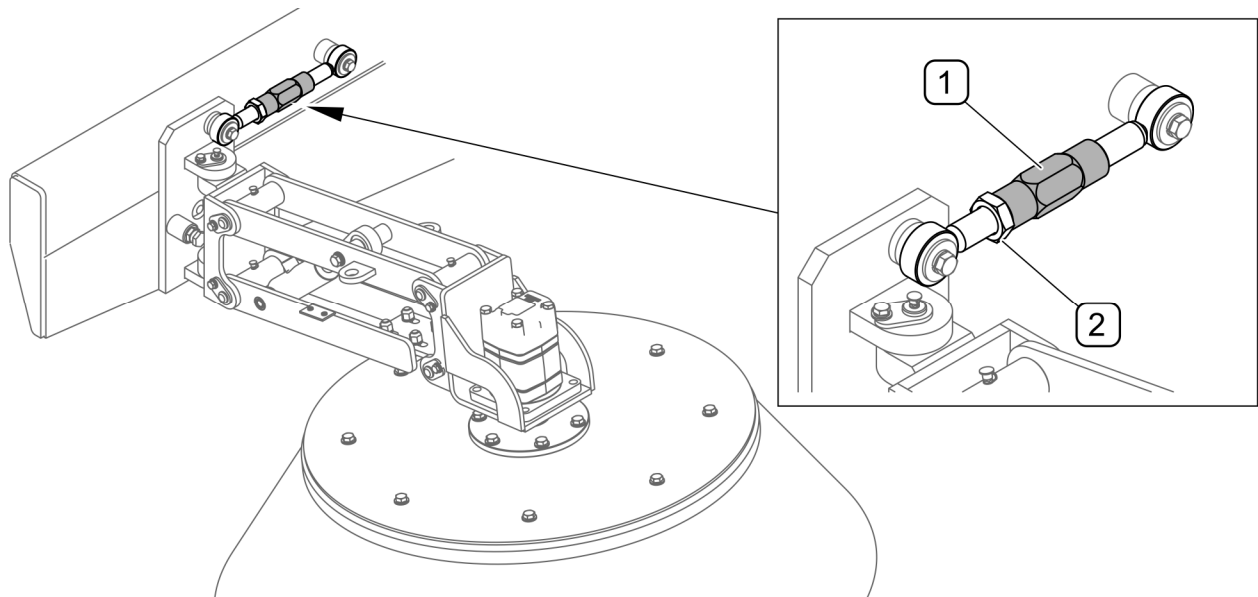

FIG. 5.4 Mechanical adjustment of lateral inclination of the left brush

(1) - tensioner; (2) - securing nut

In the sweepers with mechanical adjustment of the left brush (FIG. 5.4), lateral inclination of the brush is changed by means of tensioner (1). Before the adjustment, loosen nut (2) and then, set proper inclination of the brush by turning the tensioner. After adjustment, tighten securing nut (2).

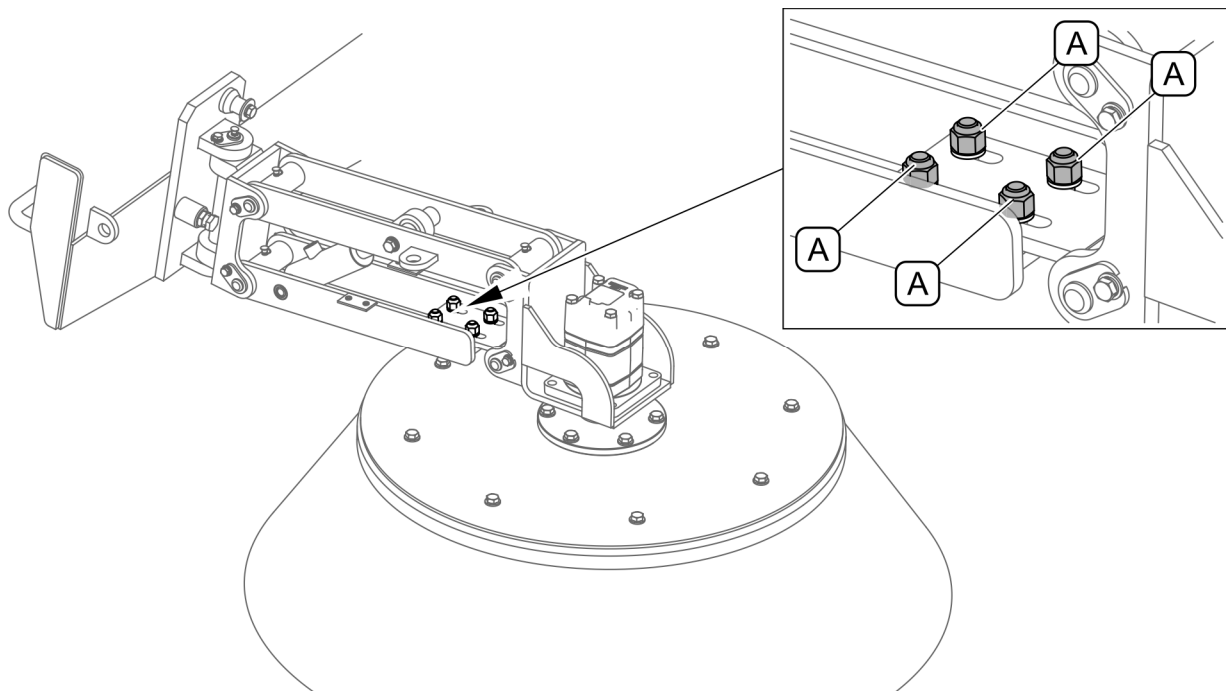

FIG. 5.5 Adjustment of longitudinal inclination of disc brushes

(A) - bolts for adjusting longitudinal inclination of disk brushes

In order to adjust longitudinal inclination (FIG. 5.5), loosen nuts of bolts (A) (4 nuts for the right brush and 4 nuts for the left brush) and then, move securing bracket forwards or backwards. Longitudinal inclination of the right and left brush is set in the same manner. After adjustment, tighten nuts of bolts (A).

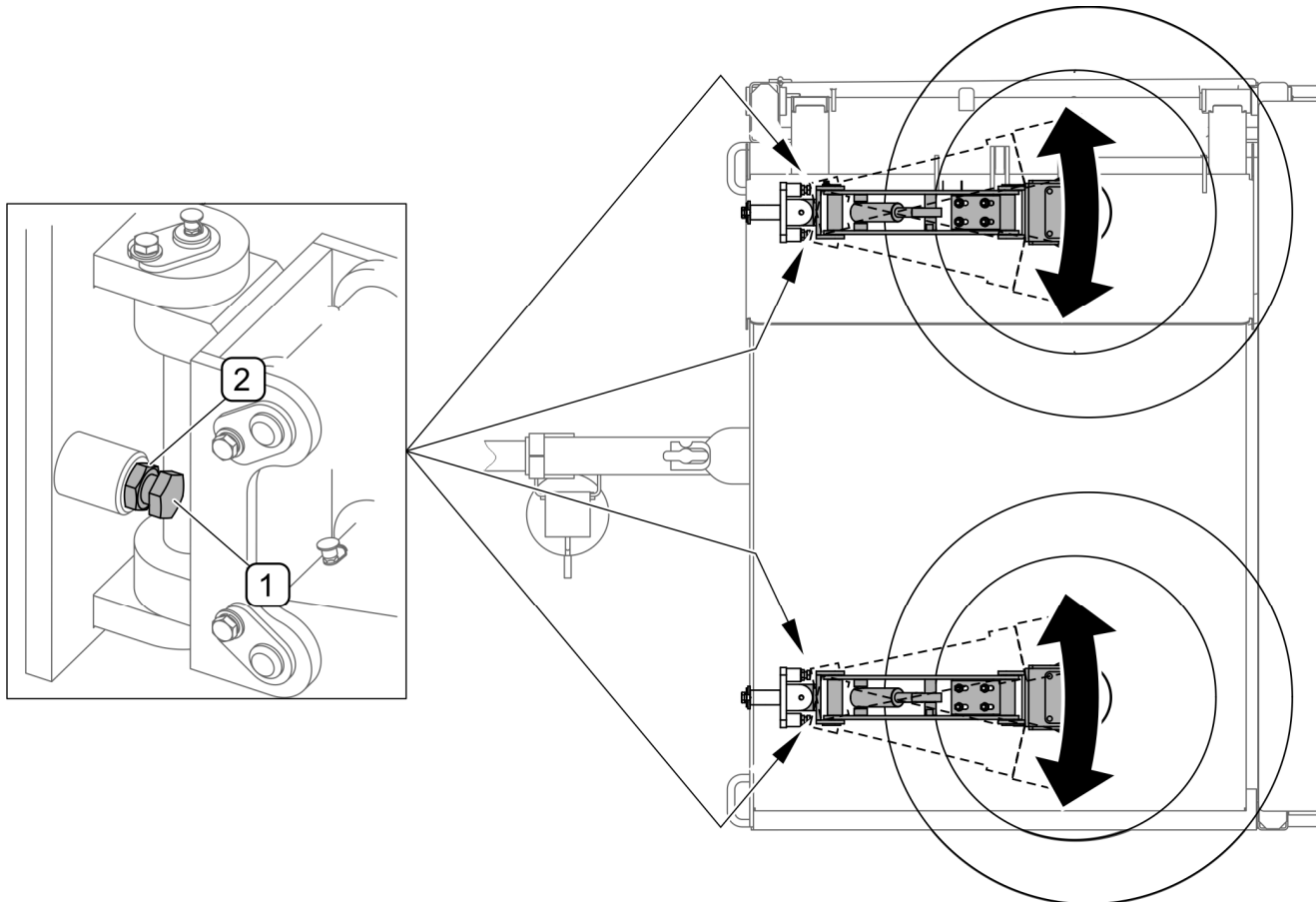

FIG. 5.6 Adjustment of disc brush side tipping

(1) - side tilt bumper; (2) - counter nut

During sweeper operation, the right and left disk brushes (FIG. 5.6) move to the outside of the machine. Range of horizontal movement of brushes is limited with bumper (1). There are two limiting bumpers in each of the roller brushes. In order to change position of bumpers (1), loosen counter nut (2) and then, screw in or screw out the bumper (1). After adjustment, tighten counter nut (2). Right brush and left brush can be set depending on a required sweeping width.

5.2.2 ADJUSTMENT OF ROLLER BRUSH

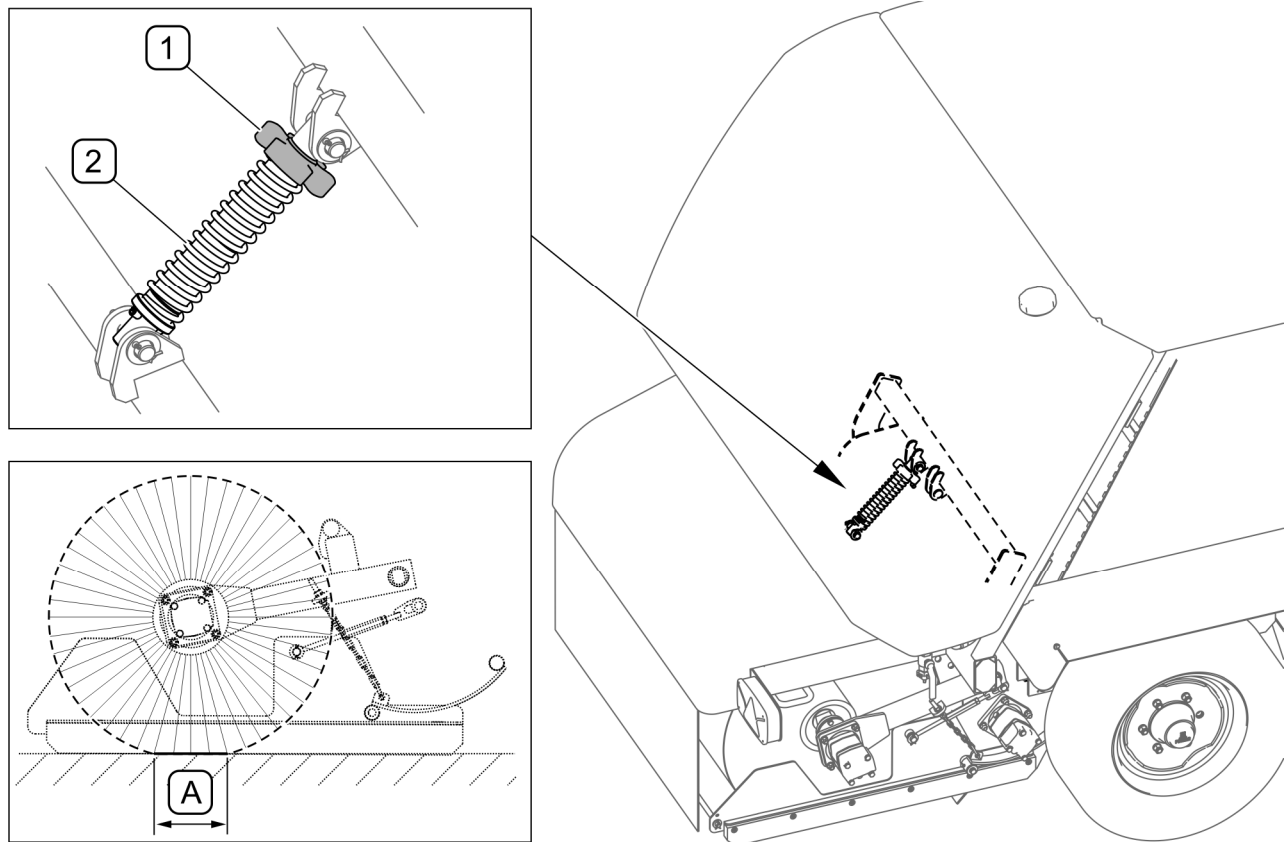

FIG. 5.7 Adjustment of roller brush pressure

(1) - tensioning nut; (2) - spring; (A) - surface of roller brush pressure to the ground
100 – 150 mm

Surface of roller brush pressure (A) to the ground should be within 100 - 150 mm (FIG. 5.7). Setting the roller brush pressure involves the adjustment of spring (2) tension and is carried out by means of nut (1). Excessive pressure of brush on the surface increases wear of brush.

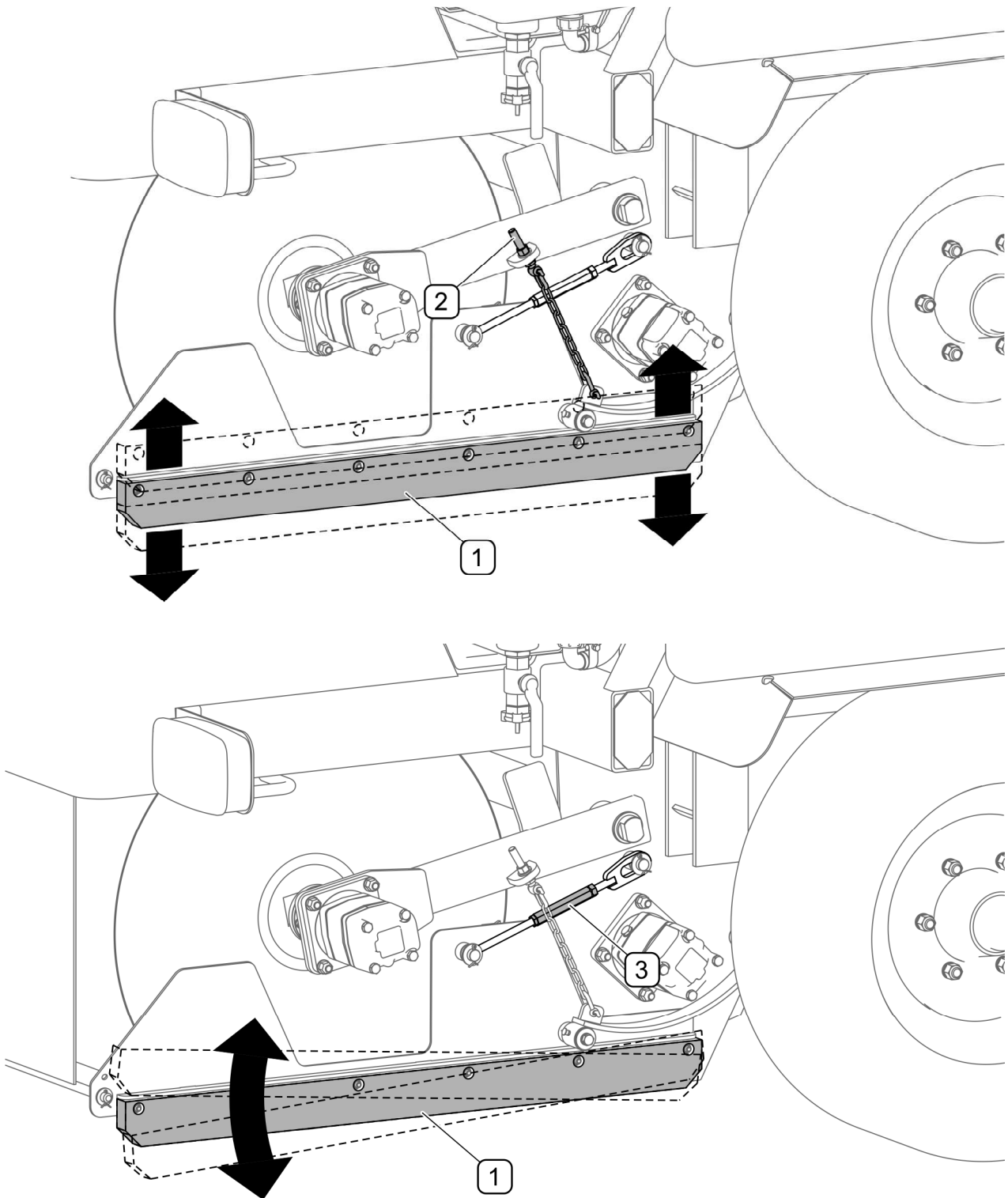

FIG. 5.8 Adjustment of side slides
 (1) - slide; (2) - chain tensioner; (3) - double ended bolt

There are slides on both sides of the roller brush (FIG. 5.8). Position of slides with regard to the ground as well as their technical condition should be checked periodically. Slide should be positioned in such a manner as to slightly touch surface cleaned. Slide (1) suspension height is set by means of chain tensioner (2). If the range of tensioner (2) is insufficient,

shorten the chain by changing position of shackles. Slide inclination (FIG. 5.8) is set by means of double ended bolt (3). Slide should be set in parallel to the surface cleaned. Positions of the slides on the right and left sides of the brush should be the same.

5.2.3 ADJUSTMENT OF ELEVATOR BELTS

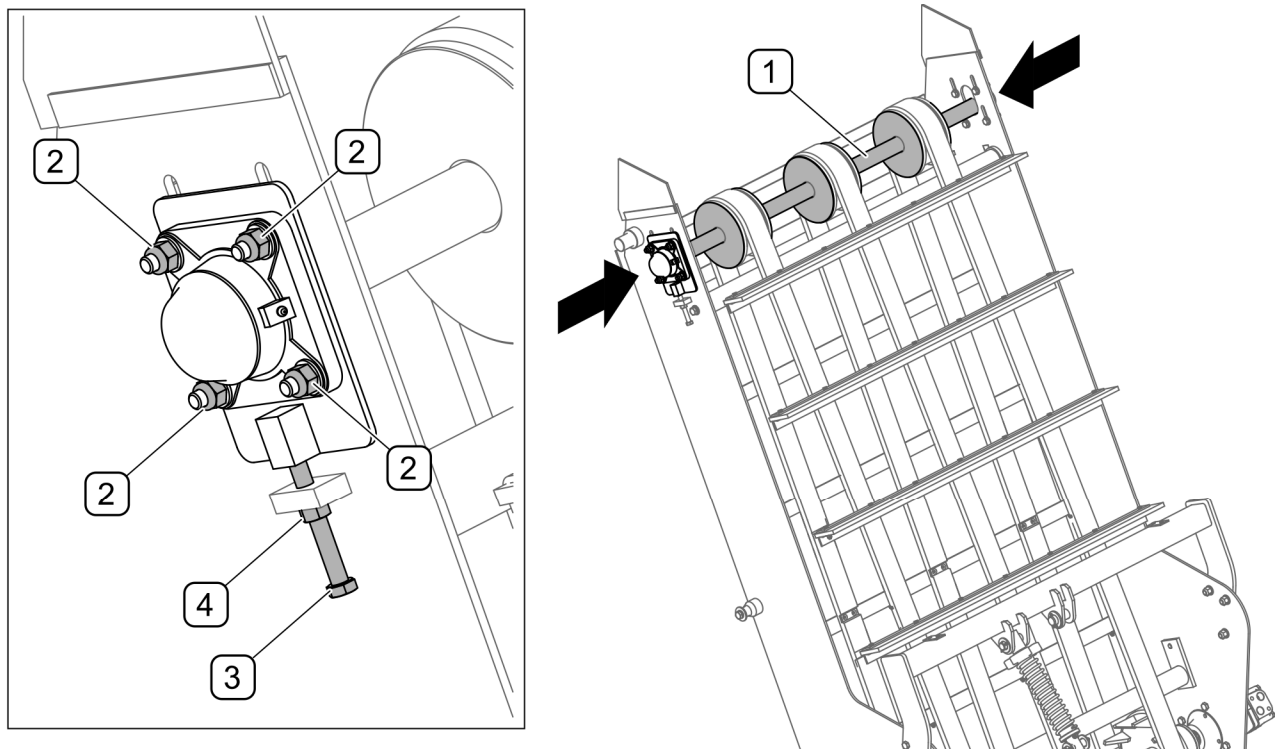



FIG. 5.9 Tightening the elevator belts

(1) - tightening shaft; (2) - shaft bearing nuts; (3) - tensioner bolt; (4) - counter nut

Tightening of belts (FIG. 5.9) is carried out on both sides of the elevator. After loosening of 4 bolts (2) and nut (4), move tightening shaft (1) by means of tensioner bolt (3). Perform this activity on both sides of the elevator. After adjustment, tighten counter nuts (4) and nuts (2) that fix the tightening shaft bearing.

5.3 REPLACEMENT OF BRUSHES AND ELEVATOR COMPONENTS

5.3.1 REPLACEMENT OF DISK BRUSHES



DANGER

Before inspection and replacement of brushes, turn off the machine drive, switch off the tractor's engine and the control panel and ensure that unauthorised persons have no access to the vehicle cab.

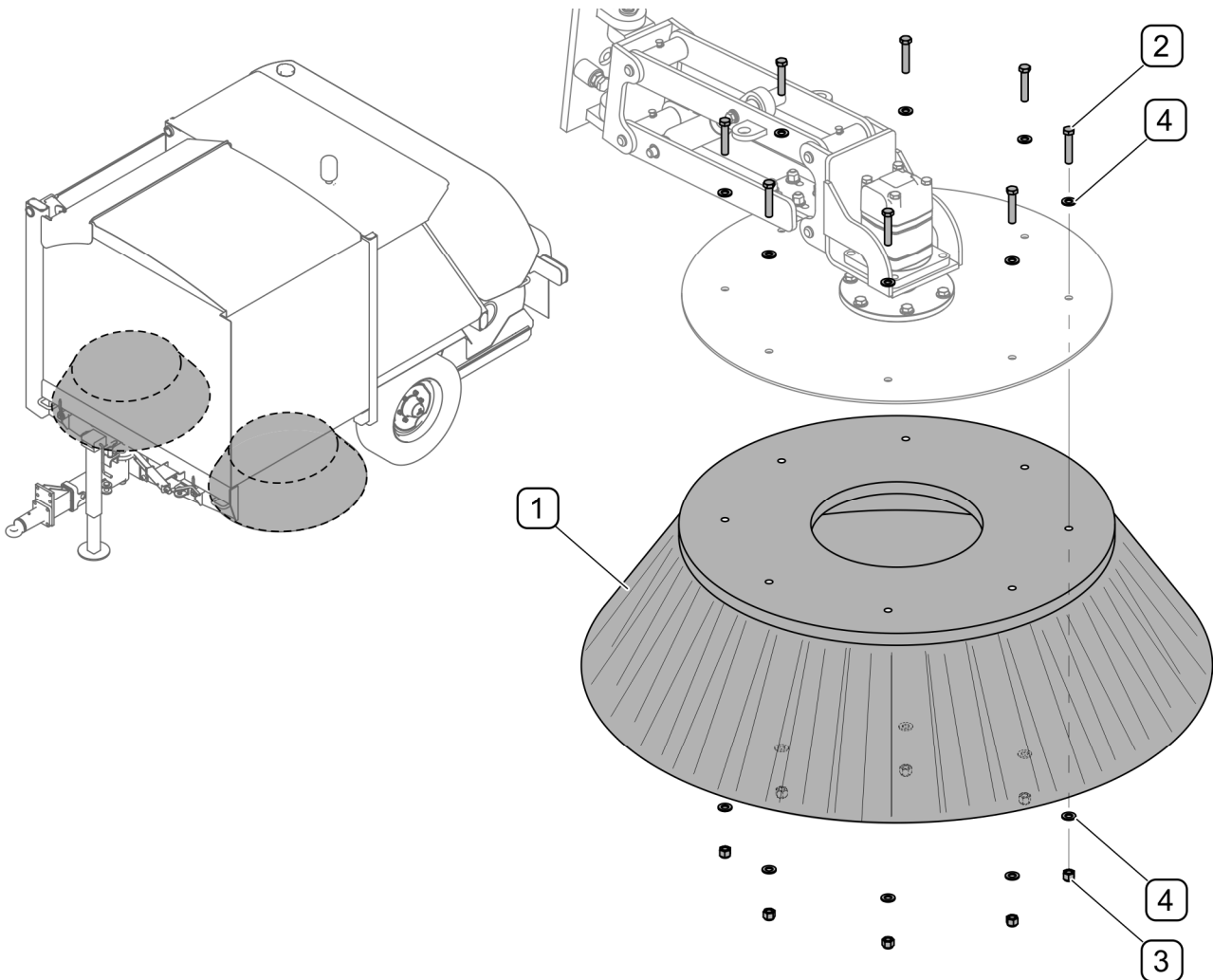

FIG. 5.10 Replacement of disk brushes

(1) - disk brush; (2) - bolt; (3) - nut; (4) - washer

Technical condition of disk brushes should be checked periodically. Excessively worn brushes must be replaced with new ones. The sweeper is equipped with two identical disk brushes. List of disk brush components is shown in (TAB. 5.1).

Replace the disc brush (FIG. 5.10) as follows:

- undo nuts (3) of brush fixing bolts (8 pcs);
- replace worn brush (1),
- insert bolts (2) and washers and tighten nuts (3).

TAB. 5.1 COMPONENTS OF DISK BRUSH

ITEM	NAME AND PART NUMBER	NUMBER OF ITEMS [item]
1	Disk brush 760x1,100 100.A473	1
2	Bolt M12x60-8.8-A2J PN-EN ISO 4014	8
3	Self-locking nut M12-8-A2J PN-EN ISO 7040	8
4	Washer 12-100HV-Fe//Zn6//A PN-EN ISO 7091	16

The quantities in the table are given for one disk brush

5.3.2 REPLACING THE ROLLER BRUSH

Technical condition of roller brush (FIG. 5.11) should be checked periodically. Excessively worn brush should be replaced.

To remove the roller brush:

- On the left side of the brush, undo and remove bolts (5) that fix the bearing to the brush bracket (A, FIG. 5.11)
- On the right side of the brush, undo and remove bolts (6) that fix the brush axis to the hydraulic motor (B, FIG. 5.11)
- Slide the brush to the rear from the bracket (C, FIG. 5.11)
- Remove mounting with bearing (4), loosen and remove interlock (3) and take out axis (2) from the brush (D, FIG. 5.11). Install a new brush and assemble the complete unit performing the above activities in reverse sequence

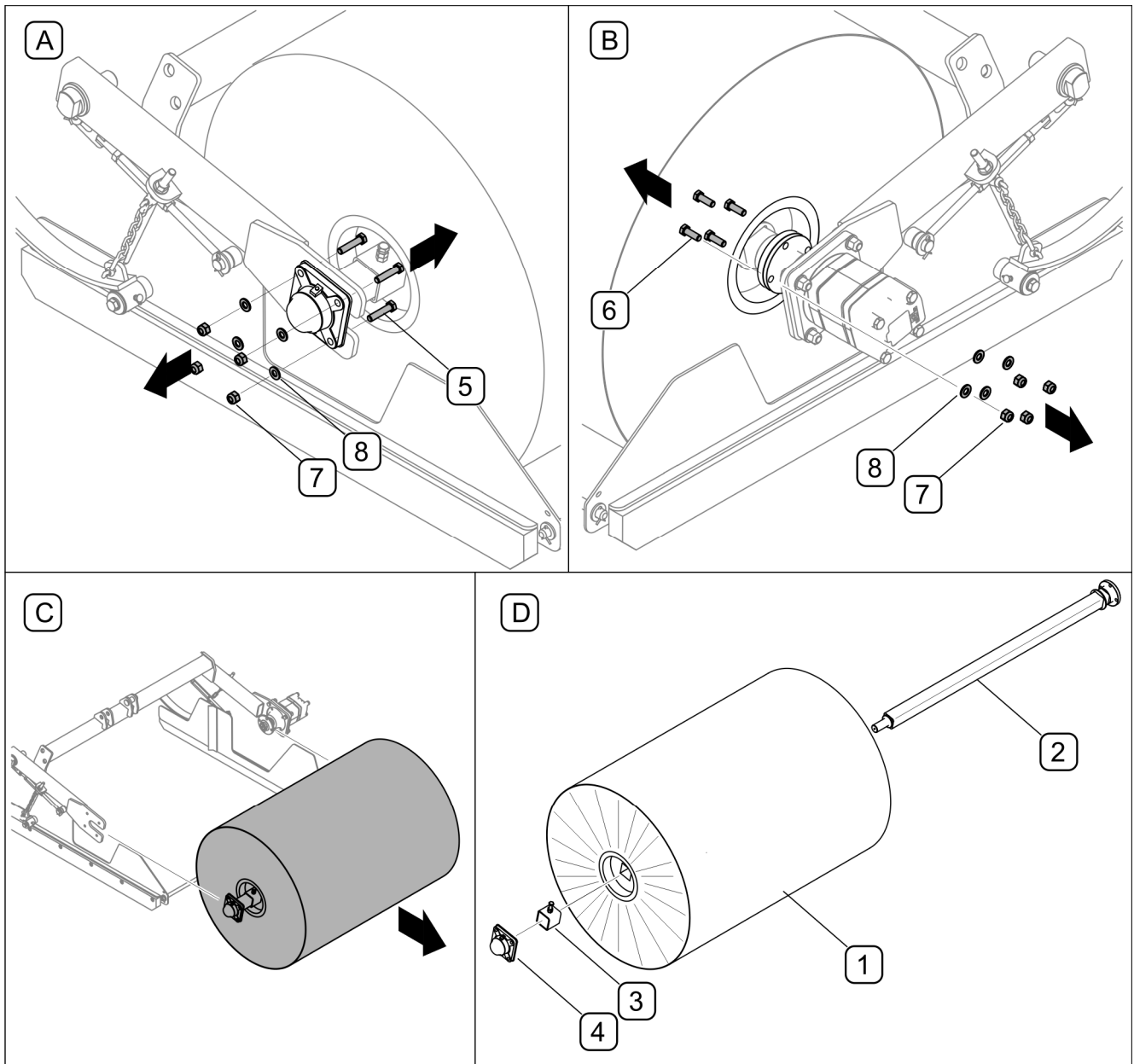

FIG. 5.11 Replacing the roller brush

(A), (B), (C), (D) - successive stages of brush replacement; (1) - roller brush; (2) - axis; (3) - interlock; (4) - mounting with bearing; (5) - M10x45 bolt; (6) - M10x25 bolt; (7) - M10 nut; (8) - 10-100HV washer

TAB. 5.2 COMPONENTS OF ROLLER BRUSH

ITEM	NAME / CATALOGUE NO.	NUMBER OF ITEMS [item]
1	Roller brush / 127.000	1
2	Brush axis / 344N-06020000	1
3	Interlock / 344N-06050000	1
4	Mounting with bearing / FY 30 TF ECY	1
5	Bolt M10x45-8.8-A2J / PN-EN ISO 4017	4
6	Bolt M10x35-8.8-A2J PN-EN ISO 4017	4
7	Nut M10-8-A2J PN-EN ISO 7040	8
8	Washer 10-100HV Fe//Zn8//A PN-EN ISO 7091	8

5.3.3 REPLACING THE ELEVATOR SCRAPERS

Technical condition of belts and elevator scrapers should be checked periodically (FIG. 5.12). Excessively worn or damaged blades must be replaced. List of elevator scraper components is shown in TAB. 5.3

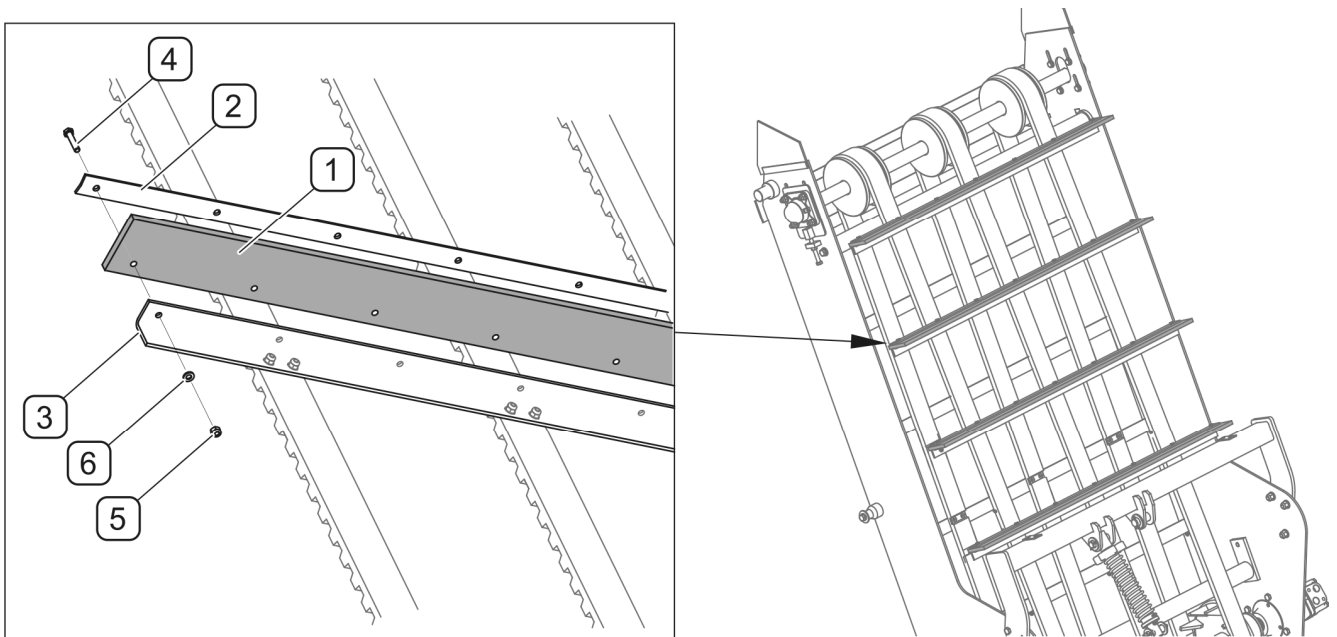
**FIG. 5.12 Replacing the elevator scrapers**

(1) - scraper; (2) - clamp; (3) - strip; (4) - M60x30-8.8 bolt; (5) - M6 nut; (6) - washer 6-100HV

TAB. 5.3 LIST OF SCRAPER COMPONENTS

MARKING (FIG. 5.12)	NAME CATALOGUE NO.	NUMBER OF ITEMS (for 1 scraper)
1	Scraper 344N-05090003	1
2	Clamp 344N-05090004	1
3	Strip 344N-05090002	1
4	Bolt M6x30-8.8-A2J PN-EN ISO 4017	7
5	Self-locking nut. M6-8-A2J PN-EN ISO 7040	7
6	Washer 6-100HV-Fe//Zn6//A PN-EN ISO 7091	7

The quantities are given for one scraper. The sweeper is equipped with 13 scrapers

5.4 HYDRAULIC SYSTEM MAINTENANCE



DANGER

During work on hydraulic systems use the appropriate personal protection equipment i.e. protective clothing, footwear, gloves and eye protection. Avoid contact of skin with oil.

The duties of the operator connected with the hydraulic system include:

- checking oil level in the hydraulic system tank,
- checking tightness of cylinders hydraulic connections,
- checking technical condition of lines,
- periodical replacement of filters,
- periodical changing of oil in the hydraulic system tank



DANGER

Do not repair hydraulic system on your own. All hydraulic system repairs must be performed only by suitably qualified personnel.

**ATTENTION!**

The condition of hydraulic system should be inspected regularly while using the machine.



Hydraulic lines should be replaced after 4 years of machine use.

Detailed tightness and technical condition inspection of hydraulic system should be made at least annually.

The sweeper's hydraulic system should be completely tight. Checking tightness of the hydraulic system involves connecting the sweeper with the tractor and activating the hydraulic system. In the event of confirmation of an oil leak on hydraulic line connections, tighten connections, and if this does not remedy faults then change line or connection elements. If oil leak occurs beyond connection, the leaking line system should be changed. Change of sub-assemblies is equally required in each instance of mechanical damage. In the event of confirmation of damage to hydraulic motors, they must be repaired or replaced. Work connected with the repair of hydraulic system should be entrusted to the appropriately qualified persons.

The hydraulic system of new machine is factory filled with HL32 hydraulic oil.

Because of its composition the oil applied is not classified as a dangerous substance, however long-term action on the skin or eyes may cause irritation. In the event of contact of oil with skin wash the place of contact with water and soap. Do NOT apply organic solvents (petrol, kerosene). Contaminated clothing should be changed to prevent access of oil to skin. In the event of contact of oil with eye, rinse with large quantity of water and in the event of the occurrence of irritation consult a doctor. Hydraulic oil in normal conditions is not harmful to the respiratory tract. A hazard only occurs when oil is strongly atomised (oil vapour), or in the case of fire during which toxic compounds may be released.

**DANGER**

Oil fires should be quenched with carbon dioxide (CO₂), foam or extinguisher steam. Do NOT use water for fire extinguishing!

Spilt oil should be immediately collected and placed in marked tight container. Used oil should be taken to the appropriate facility dealing with the re-use of this type of waste.

TAB. 5.4 HL32 HYDRAULIC OIL CHARACTERISTICS

ITEM	NAME	VALUE
1	ISO 3448VG viscosity classification	32
2	Kinematic viscosity at 40°C	28.8 – 35.2 mm ² /s
3	ISO 6743/99 quality classification	HL
4	DIN 51502 quality classification	HL
5	Flash point, °C	Above 210°C
6	Maximum operating temperature, °C	80

ATTENTION!



Rotary rake with a leaking hydraulic system must NOT be used.
The condition of hydraulic systems should be inspected regularly while using the machine.
The hydraulic system is under high pressure when operating.
Regularly check the technical condition of the connections and the hydraulic lines.
Use the hydraulic oil recommended by the Manufacturer. Never mix two types of oil.

Should it be necessary to change hydraulic oil for another oil, check the recommendations of the oil Manufacturer. If it is recommended to flush the system with the appropriate preparation, then comply with these recommendations. Attention should be given, so that chemical substances used for this purpose do not damage the materials of the hydraulic system.



DANGER
Before commencing whatever work on hydraulic system reduce the residual pressure in the system.



DANGER
Activities connected with maintenance of hydraulic system (inspection, replacing and adding oil, replacing filters) should be carried out only when the machine is switched off.
During maintenance work concerning the machine, „EMERGENCY STOP” push-button on the control panel should be depressed.

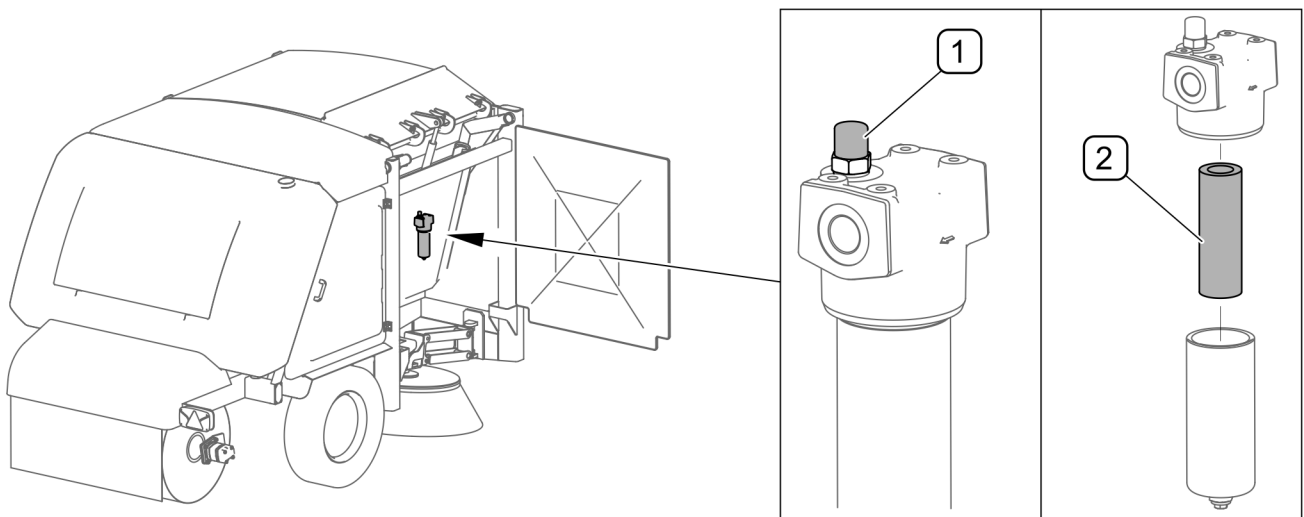

FIG. 5.13 Pressure oil filter

(1) - filter contamination indicator; (2) - filter cartridge

Pressure oil filter (FIG. 5.13) is equipped with contamination indicator. If filter cartridge is contaminated, the indicator changes its colour to red. Within the scope of hydraulic system maintenance, check the indicator (1) and replace filter cartridge (2), if necessary. Open front right-hand shield in order to gain access to the pressure oil filter.

In order to replace pressure filter cartridge (FIG. 5.13):

- unscrew lower part of filter housing,
- replace filter cartridge (2) with a new one,
- tighten lower part of filter housing.

The hydraulic system is vented automatically during machine operation.



TIP

Pressure filter in the hydraulic system is equipped with a replaceable filter cartridge with part number of 944431Q



Filter cartridge of pressure oil filter should be replaced when the indicator located on the filter indicates filter contamination. The indicator should be checked after oil has reached its working temperature.

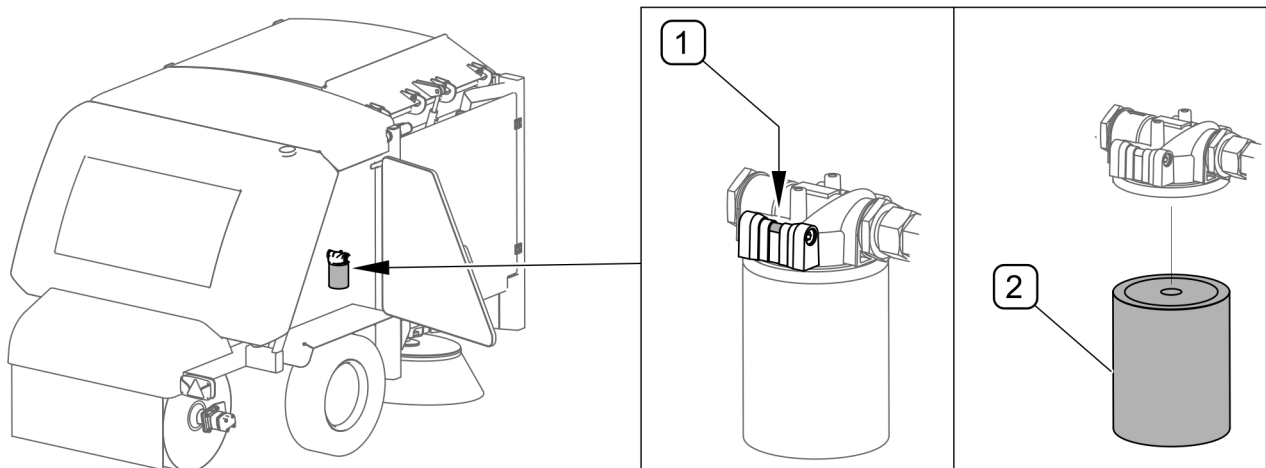

FIG. 5.14 Return oil filter

(1) - filter contamination indicator; (2) - filter

Return filter (FIG. 5.14) of hydraulic system is equipped with indicator (1). If filter is contaminated, the indicator changes its colour to red. Within the scope of hydraulic system maintenance, check the indicator and replace filter (2), if necessary. Before installing a new filter, oil the gasket surface. Open rear right-hand shield in order to gain access to the return oil filter.

The hydraulic system is vented automatically during machine operation.



TIP

Replaceable return oil filter with part number of 926503 is installed in the hydraulic system. The filter should be screwed in by hand.



Return oil filter (FIG. 5.14) should be replaced when the indicator (1) located on the filter indicates filter contamination. The indicator should be checked after oil has reached its working temperature.

Inlet filter (2) is located inside inlet opening and should be inspected and cleaned periodically. Open the rear left-hand shield in order to gain access to the inlet filter (FIG. 5.15) . Unscrew cap (1), take out mesh filter cartridge (2) and clean in washing agent.

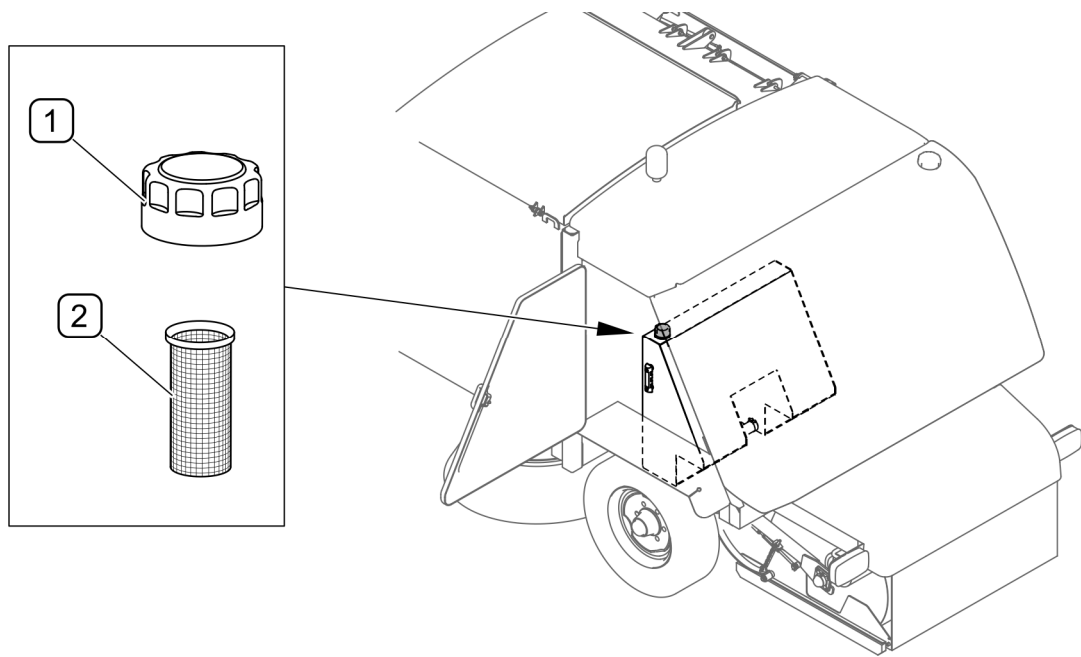

FIG. 5.15 Inlet filter

(1) - oil inlet cap; (2) - inlet filter (strainer)



Inlet filter (FIG. 5.15) should be cleaned at every oil change or top-up.

Oil tank (1) of hydraulic system contains 190 litres of HL-32 hydraulic oil. Check periodically the oil level on the oil level dipstick (4) (FIG. 5.16). Open the rear left-hand shield in order to gain access to the oil level dipstick (4).

Before changing oil, start the machine and wait until oil gets slightly warmer.



DANGER

Hot oil may cause serious skin burns.

To change oil in the hydraulic system (FIG. 5.16) tank:

- unscrew filler plug (3);
- unscrew drain plugs (2) on the bottom of the tank and drain oil to previously prepared container;
- tighten drain plugs (2), fill tank with oil and tighten filler plug (3)

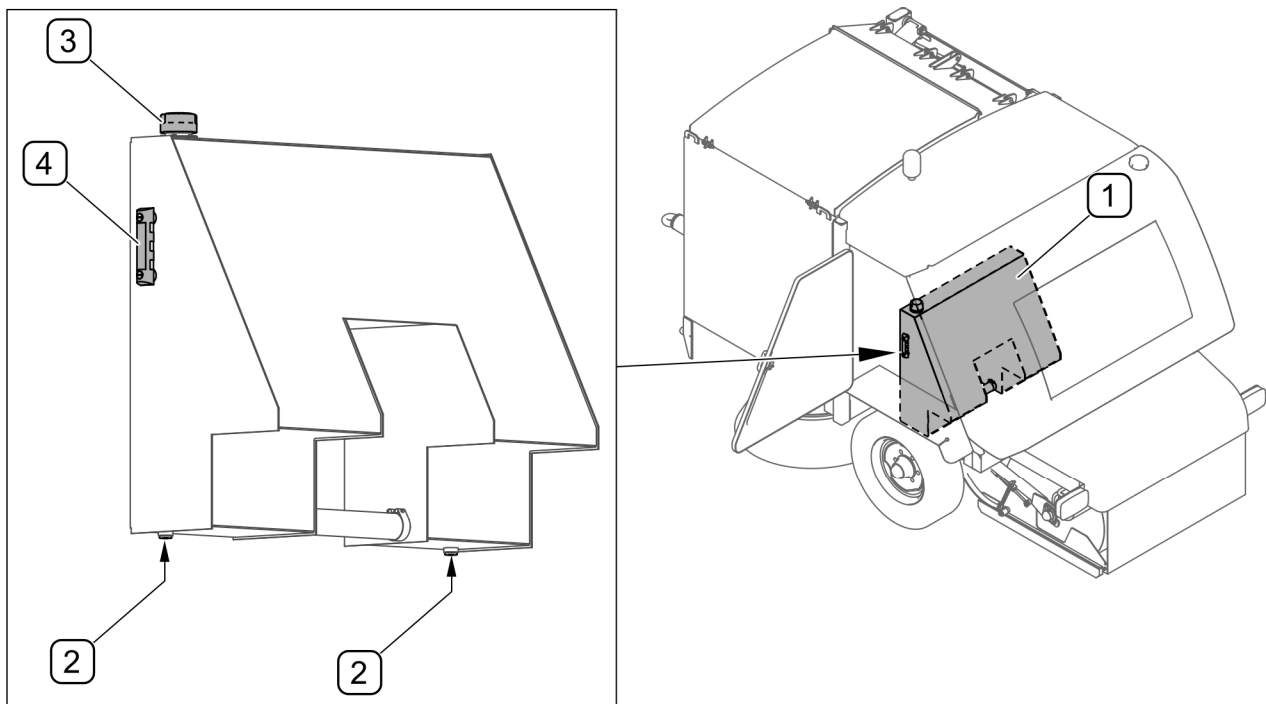

FIG. 5.16 Oil tank in hydraulic system

(1) - hydraulic oil tank; (2) - drain plugs; (3) - filler plug; (4) - oil level indicator with thermometer;

When changing oil, replace old pressure oil filter (FIG. 5.13) and return oil filter (FIG. 5.14). The hydraulic system is vented automatically during machine operation.



TIP

The hydraulic system is filled with 190L (litres) of L-HL32 hydraulic oil.



Oil in the hydraulic system tank should be replaced every 500 engine working hours or once a year, whichever occurs first.

Spilt oil should be immediately collected and placed in marked tight container. Used oil should be taken to the appropriate facility dealing with the re-use of this type of waste.

The hydraulic system should be completely tight sealed. Minimum leaks are permissible with symptoms of "sweating", however in the event of noticing leaks in the form of "droplets" stop using the machine until faults are remedied.

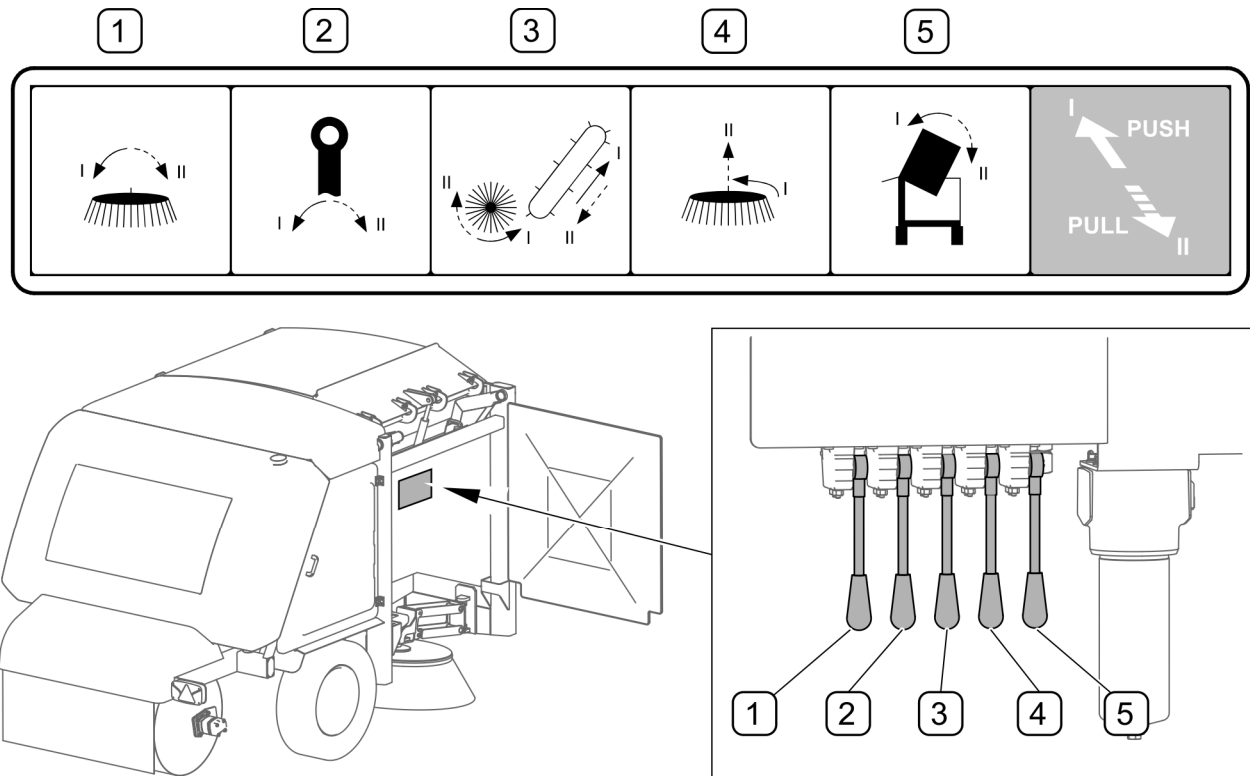



FIG. 5.17 Levers of electrohydraulic distributor

(1) - control of inclination of disk brushes; (2) - control of drawbar tilting (3) - control of rotation direction of elevator and roller brush; (4) - control of starting and rising of disk brushes; (5) - control of waste tank tipping

Electrohydraulic distributor (FIG. 5.17) enables manual activation of individual functions of the sweeper without the use of control panel. Levers of electrohydraulic distributor may be operated only when the machine is parked and when exercising particular caution. Manual control is used in case of the control panel failure or during service work in order to check individual functions of the machine. Each of the distributor levers has two functions (I and II) and the neutral (central) position. Move the lever forwards (away) to activate function "I" or pull the lever to activate function "II". Open the front right-hand shield in order to gain access to the levers of electrohydraulic distributor.

TAB. 5.5 Description of functions of electrohydraulic distributor levers

MARKING OF LEVER (FIG. 5.17)	DESCRIPTION OF FUNCTIONS OF DISTRIBUTOR LEVERS	
	FUNCTION I	FUNCTION II
1	Inclining disk brushes to the left	Inclining disk brushes to the right
2	Tilting drawbar to the left	Tilting drawbar to the right
3	Movement of elevator and roller brush in working direction	Reverse movement of elevator and roller brush <i>(for example, in order to unblock the machine)</i>
4	Starting the drive of disk brushes	Raising disk brushes
5	Start of tipping <i>(emptying)</i> the waste tank	Lowering waste tank



DANGER

Be especially careful when controlling the electrohydraulic distributor (FIG. 5.17) levers. Lever (5) may be operated only if the waste tank is empty.

Each time before starting work, check oil level in the hydraulic intensifier (FIG. 5.18). To do this, position the hydraulic intensifier body vertically, with the plug and air vent (1) at the top, and check oil level in the inspection opening (3). Proper oil level should reach the middle of the inspection opening (3).



Oil in the hydraulic intensifier (FIG. 5.18) should be replaced every 500 working hours or once a year, whichever occurs first.

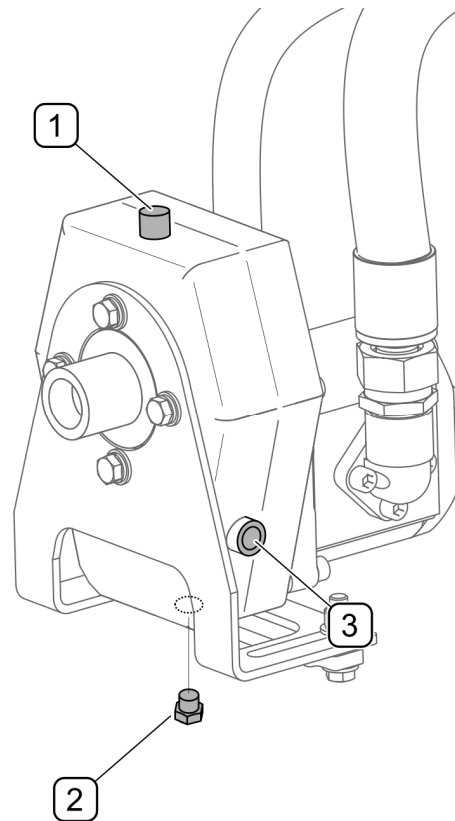

FIG. 5.18 Hydraulic intensifier

(1) - filler plug with air vent; (2) - drain plug; (3) - oil level inspection opening

To change oil in hydraulic (FIG. 5.18) intensifier:

- unscrew filler plug with air vent (1),
- unscrew drain plug (2), drain oil to previously prepared container and screw in drain plug,
- pour new oil through plug opening (1) to the level visible in the inspection opening (3),
- screw in filler plug with air vent (1)



TIP

The hydraulic intensifier is lubricated with 0.5 litre of oil of SAE 90 class.

5.5 SPRINKLER SYSTEM MAINTENANCE

Sprinkler system maintenance involves periodical inspection of water system, cleaning of water filters and checking oil level in water pump.

Before first use, check sprinkler operation, especially the setting of spray nozzles. Water nozzles should be set in such a manner as to ensure water spraying in front of the brushes' working area during sweeper operation.

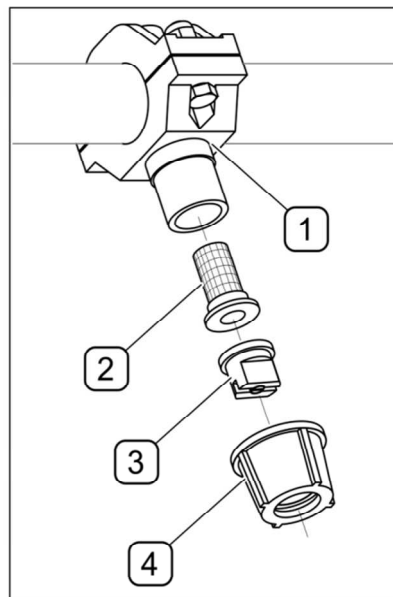

FIG. 5.19 Filters of sprinklers

(1) - bracket; (2) - filter; (3) - sprinkler; (4) - nut

Periodically confirm that sprinklers are not blocked and filters are clean (FIG. 5.19). There is a strainer (2) in the sprinkler. In order to clean the strainer, dismantle nut (4) with sprinkler (3). Rinse the strainer (2) or blow it with compressed air. Confirm that sprinkler (3) is not blocked. Check technical condition of sprinklers and, if necessary, replace damaged elements. The list of sprinkler elements TAB. 5.6

TAB. 5.6 The list of sprinkler elements

MARKING (FIG. 5.19)	NAME	CATALOGUE NO.
1+4	1/2" bracket with nut	8230012
2	Filter	8139004
3	Sprinkler	TP11006VP

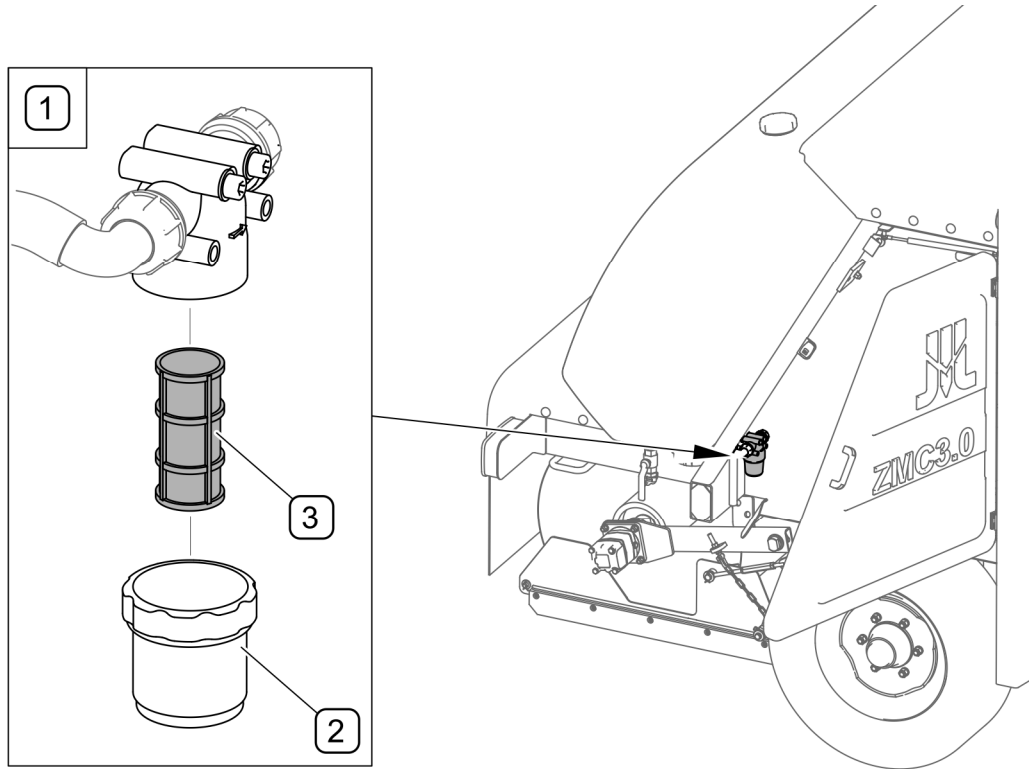

FIG. 5.20 Water filter

(1) - water filter; (2) - housing; (3) - mesh cartridge

In the sprinkler system there is a filter (FIG. 5.20) which catches mechanical contaminants. Open the rear right-hand shield in order to gain access to the water filter. In order to clean water filter, unscrew housing (2) and take out mesh cartridge (3) and wash it with water under pressure or clean with compressed air. Install cartridge, tighten housing elements and check tightness of connection.



TIP

Water filter in the sprinkler system is equipped with reusable mesh cartridge with part number of C00100005. Damaged cartridge should be replaced with a new one.



Water filters are recommended to be cleaned at least once a year. Frequency of filter cleaning depends on amount and size of water contamination.

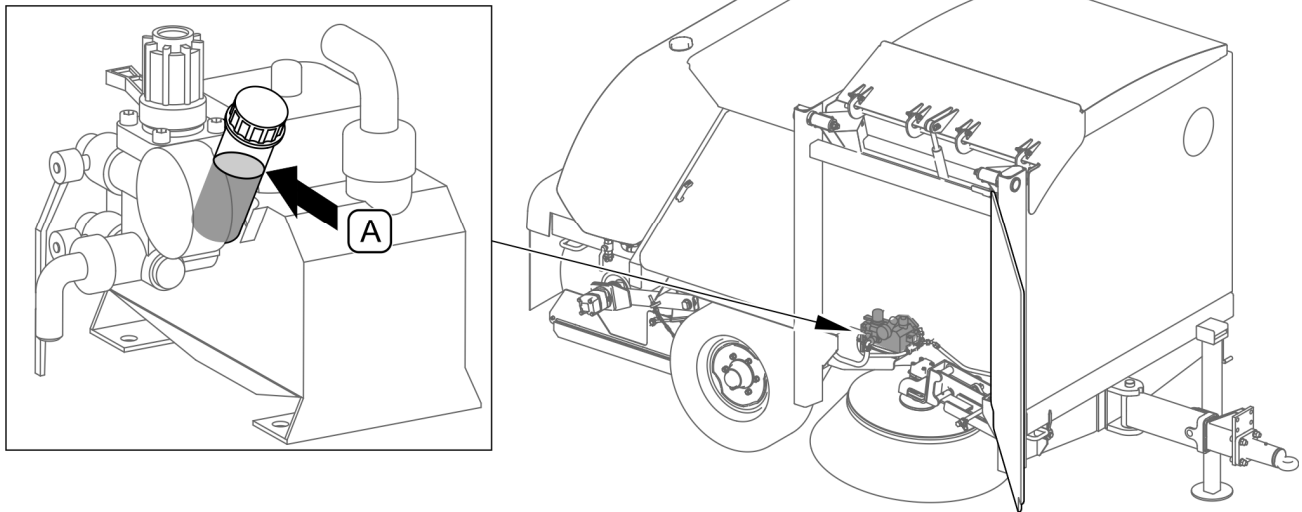

FIG. 5.21 Oil tank of water pump

(A) - oil level in oil tank of water pump

The sprinkler system contains water pump equipped with its own lubrication system.



DANGER

Switch off the machine before checking oil level in the lubrication system and changing water pump's settings.

Level of oil in the water pump lubrication system should be checked periodically. When the machine is switched off, oil level (A) in the water pump lubrication system should be between „min” and „max” marks visible on the inlet tube (FIG. 5.21).



TIP

Water pump lubrication system is filled with mineral oil of SAE 10W40 or 15W30 class for gasoline engines.



IMPORTANT!

Maximum water pressure during sprinkler system operation must not exceed 0.3 MPa (3 bar).

5.6 ELECTRICAL SYSTEM MAINTENANCE



DANGER

Do not independently repair electrical system, except items described in chapter ELECTRICAL SYSTEM MAINTENANCE. All electrical system repairs must be performed only by suitably qualified personnel.

Electrical system maintenance is conducted during the periodical checking the operation of control and lighting system.

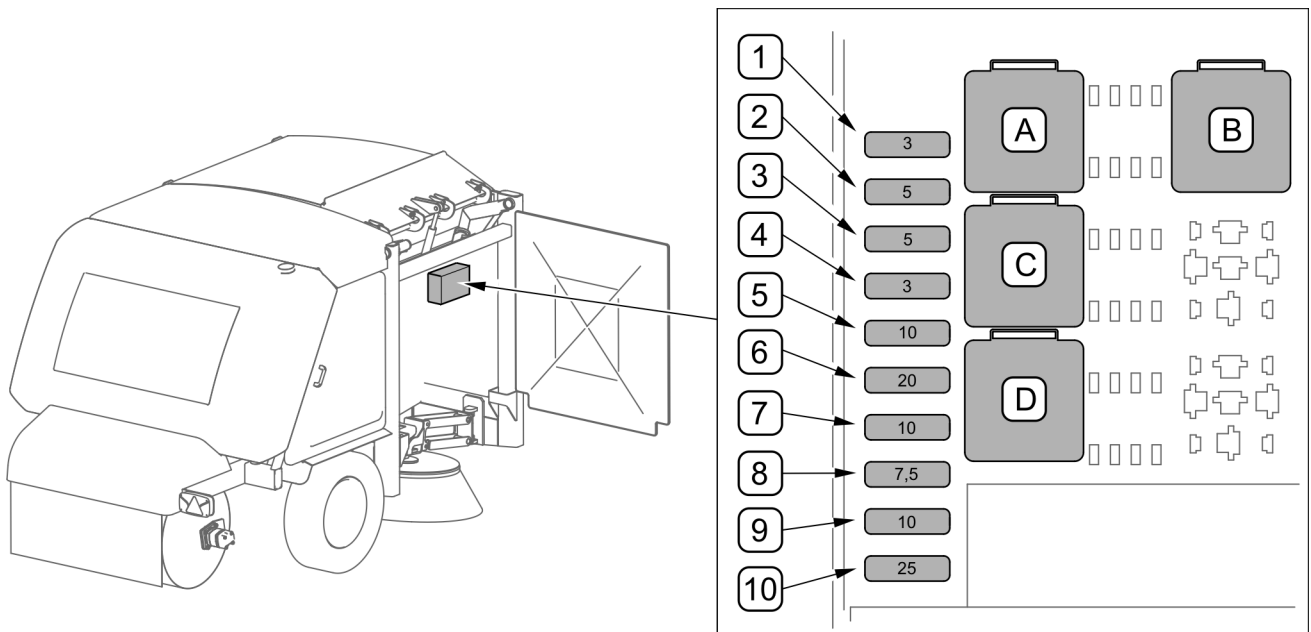

FIG. 5.22 Fuses and relays of electrical system

Description of fuses and relays is presented in TAB. 5.7

Fuses (FIG. 5.22) of electrical system are located in the control unit's housing. Open front right-hand shield in order to gain access to the control unit housing Fuse description is presented in TAB. 5.7

TAB. 5.7 Description of fuses and relays of electrical system

FUSES		
MARKING (FIG. 5.22)	PROTECTED CIRCUIT	AMPERAGE [A]
1	Protection of control unit's inputs	3
2	Protection of control unit's outputs (outputs 0-7)	5
3	Protection of control unit's outputs (outputs 8-12)	5
4	Video camera (option);	3
5	Control unit power supply switch	10
6	Power supply of solenoid valves (sweeping; raising the brushes; water pump, inclination of left/right brush, reverse movement of elevator; movement of drawbar to the right/left)	20
7	Power supply of relay C	10
8	Power supply of relay A	7.5
9	Working lights (option)	10
10	Tank vibrator (option)	25
RELAYS		
MARKING (FIG. 5.22)	DESCRIPTION	
A	Relay activated by the control unit, energizing the following circuits: <ul style="list-style-type: none"> - switch of beacon light; - switch for waste tank rising/lowering; - switch of the waste tank's vibrator; - power supply of sensors that detect opening of side shields; - power supply of sensors that detect the waste tank rising; - power supply of oil pressure sensor (signalling the elevator blocking); - power supply of low oil level sensor 	
B	relay of the waste tank rising	
C	relay of power supply of beacon light	
D	relay of opening of side shields	

Relays of 561-12V/30A type are used in the electrical system

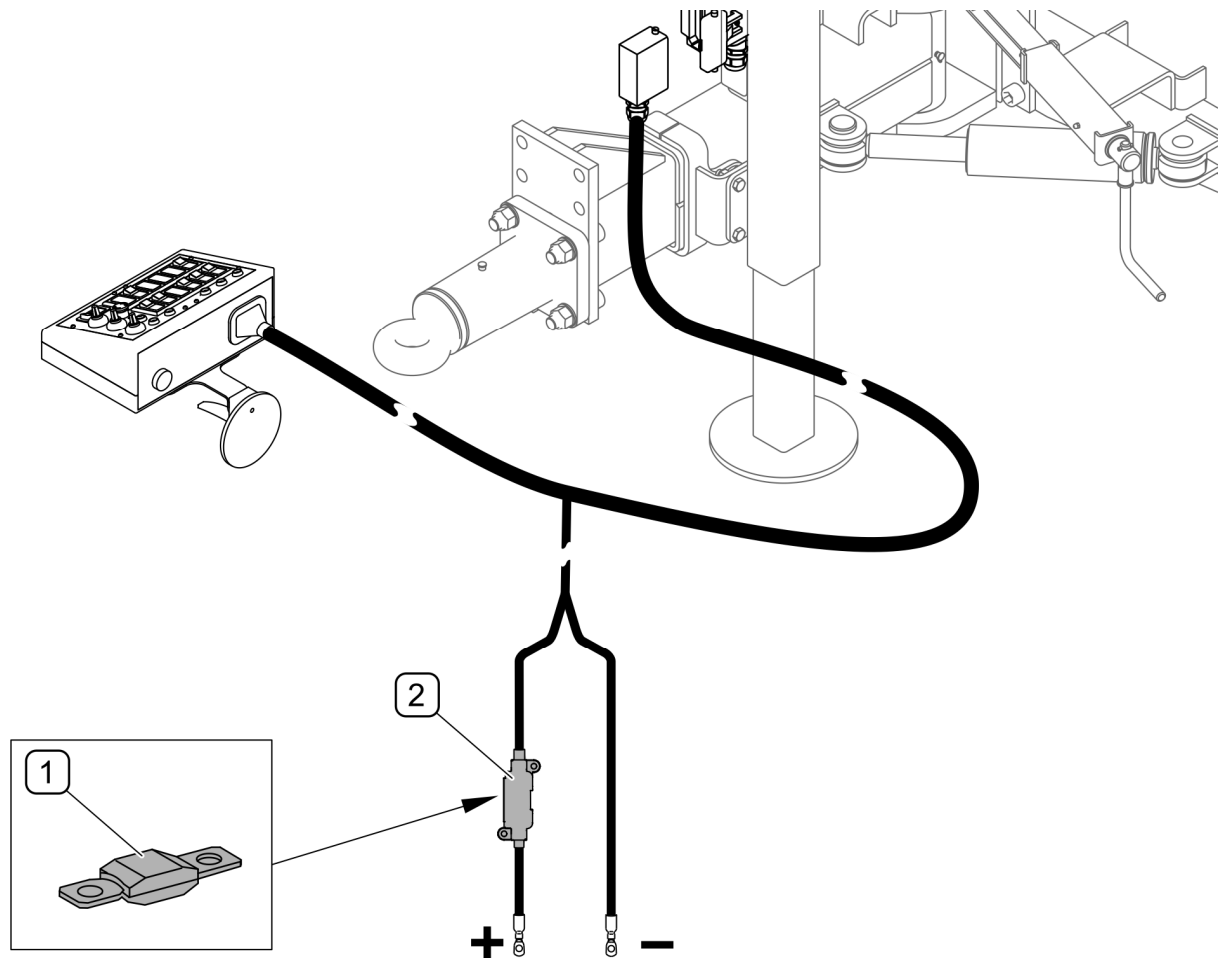

FIG. 5.23 Fuse of the sweeper's power supply

(1) - MIDIVAL 50A fuse; (2) - fuse holder

MIDIVAL 50A fuse (1) is installed in holder (2) on the power lead connected to the positive end of the tractor's battery (FIG. 5.23)

5.7 BRAKES ADJUSTMENT

5.7.1 ADJUSTMENT OF MAIN BRAKES

Brakes adjustment is necessary when:

- as a result of wear of brake shoe linings between lining and drum there is excessive slack and reduced braking effectiveness,
- wheel brakes do not brake evenly or simultaneously.

If brakes are correctly adjusted, braking of machine road wheel takes place simultaneously.

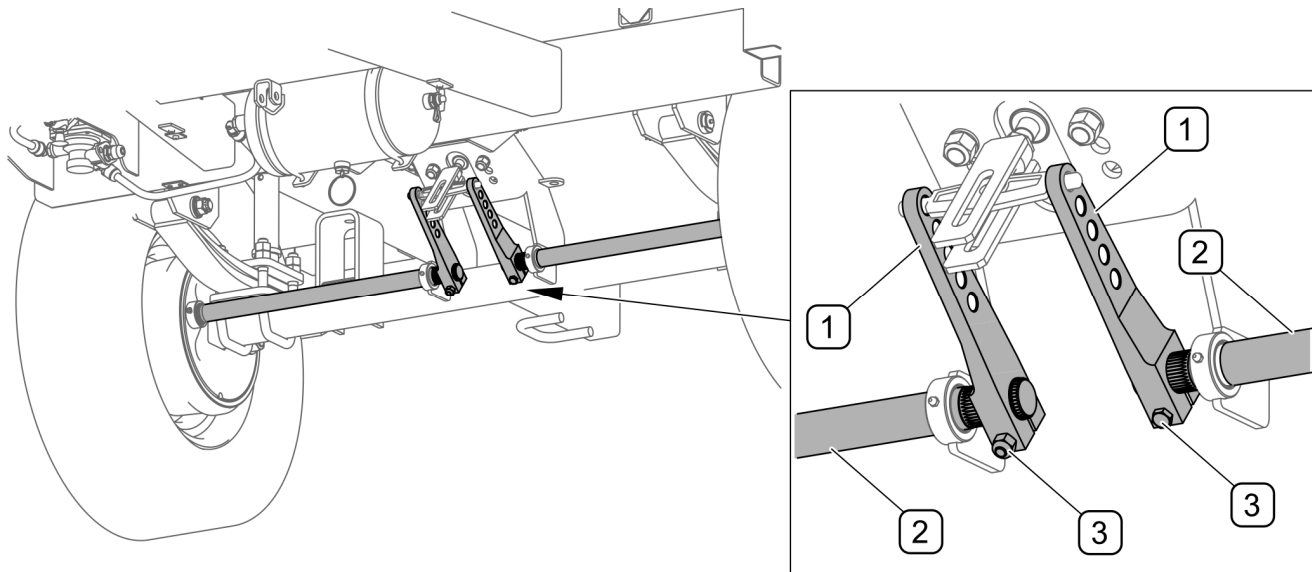

FIG. 5.24 Adjustment of main brakes

(1) - expander arm; (2) - expander shaft; (3) - clamp bolt

Brakes adjustment (FIG. 5.24) involves changing setting of axle shaft expander arm (1) in relation to expander shaft (2). To do this, loosen nut of bolt (3), and then move expander arm (1) on the multisplined end of shaft (2) in the appropriate direction, that is:

- in direction of hydraulic cylinder - if brake brakes too late,
- In direction from hydraulic cylinder - brake brakes too early.

Adjustment should be conducted separately for each wheel. After proper brake adjustment, at full braking the expanders' arms should create the angle of 90° with the pneumatic cylinder piston.



The main brake system should be inspected annually and in case of need should be adjusted.

5.7.2 PARKING BRAKE ADJUSTMENT

Adjustment of parking brake should be conducted in the event of:

- stretching of cable,
- loosening of parking brake cable clamps
- after adjustment of main brake,
- after repairs in main brake system,

- after repairs in parking brake system.

Before commencing adjustment make certain that the main break is functioning properly. Length of parking brake cable should be so selected that at total release of working and parking brake the cable would be loose.

5.8 PNEUMATIC SYSTEM MAINTENANCE



IMPORTANT!

Repair, exchange or regeneration of pneumatic system components may only be performed in a specialised workshop.

The duties of the operator connected with the pneumatic system include:

- cleaning the air filters,
- cleaning and maintaining pneumatic line connections,
- draining water from a tank, cleaning drain valve;
- checking air tightness of pneumatic system.

Work connected with the repair, change or regeneration of system elements (cylinder, lines, control valve etc.) should be entrusted to specialist establishments, having the appropriate technology and qualifications for this type of work.

As a part of sweeper maintenance, conduct inspection of pneumatic system leaktightness, paying particular attention to all places of connection. Tightness of the system should be checked at nominal pressure in the system.

If lines, seals or other system elements are damaged, compressed air will escape in these damaged places with a characteristic hiss. It is recommended to supply preparations commercially available designed to facilitate discovering air leaks. Small leaks may be exposed by covering checked elements with washing fluid or other foaming preparations, which will not react aggressively with system components. Damaged components should be replaced or repaired. If leaks appear at connections then tighten the connections. If air continues to escape replace connection component or seal.



Check system tightness:

- after passing the first 1,000 km,
- each time after making repairs or changing system components,
- annually.

During tightness inspection attention should additionally be given to technical condition and degree of cleanness of the system components. Contact of pneumatic line seals etc. with oil, grease, petrol etc. may cause damage and accelerate the ageing process. Bent lines, permanently deformed, cut or worn should be replaced.

Condensation collecting (FIG. 5.25) as water should be removed from air tank periodically. In order to do this open out drain valve (2) placed in lower part of tank (1). The compressed air in the tank causes the removal of water to the exterior. After release valve stem (2) should automatically close and stop airflow from tank. In the event, that the valve stem resists returning to its setting, then the whole drain valve must be unscrewed and cleaned, or replaced (if it is damaged).

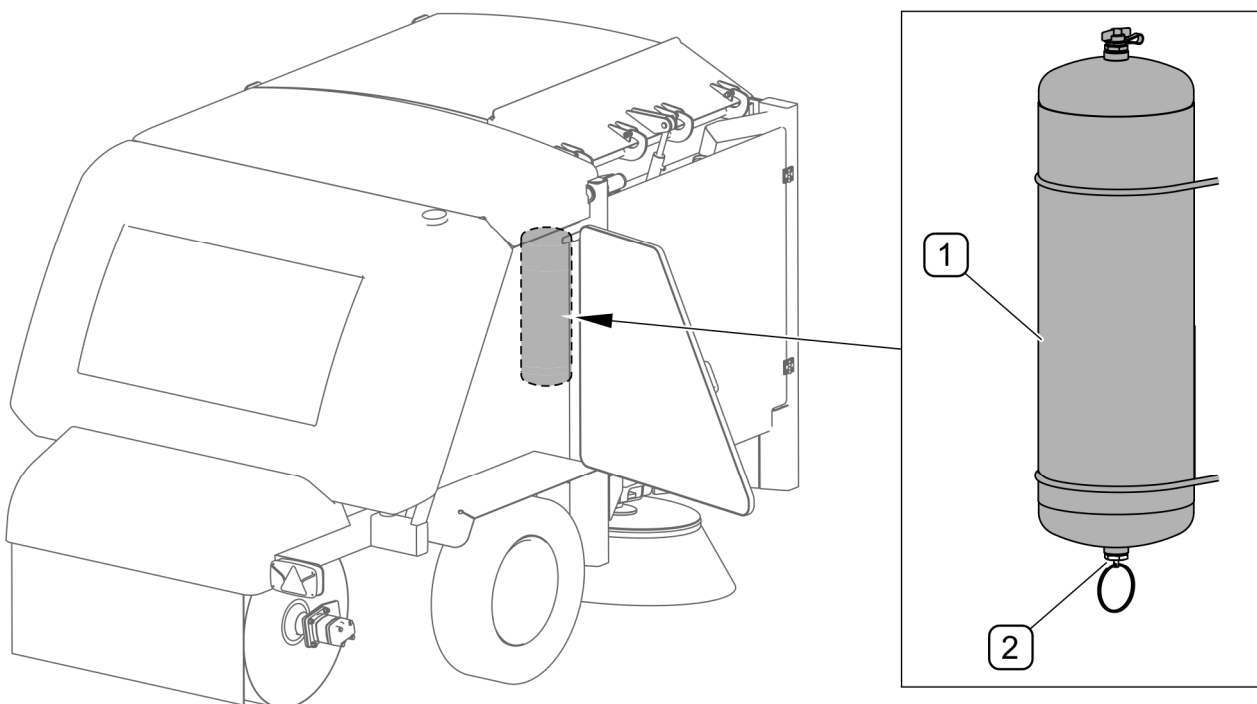

FIG. 5.25 **Draining water from air tank**

(1)- air tank; (2)- drain valve



Annually before the winter period unscrew and clean drain valve of air tank (FIG. 5.25),
Replace copper seal



DANGER

Before dismantling drain valve reduce pressure in air tank.

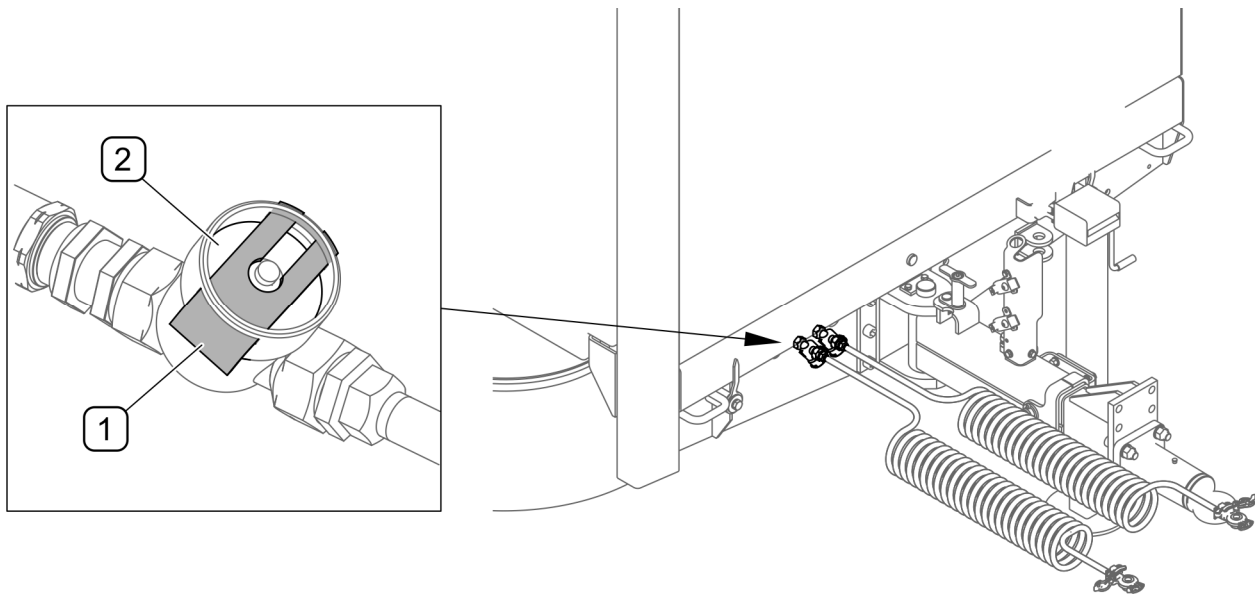

FIG. 5.26 Air filters

(1) - securing slide lock; (2) - air filter cover

Depending on machine working conditions, but not less than once in three months, take out and clean air filter (FIG. 5.26) cartridges, which are located in pneumatic system connection lines. Inserts are used many times and are not subject to changing unless they are mechanically damaged. In order to clean cartridge first reduce pressure in supply line. Next, remove securing slide (1); hold the filter cover with the other hand. After removing slide lock (1), the cover is pushed off by the spring, in the filter housing. The insert and the filter body should be carefully washed out and blown through with compressed air. Install in reverse order.



The insert and the air filter body (FIG. 5.26) should be cleaned at least every 3 months of machine use.



DANGER

Before proceeding to disassemble filter (FIG. 5.26), reduce pressure in supply line. While disengaging filter slide gate, hold cover with other hand. Stand away from filter cover vertical direction.

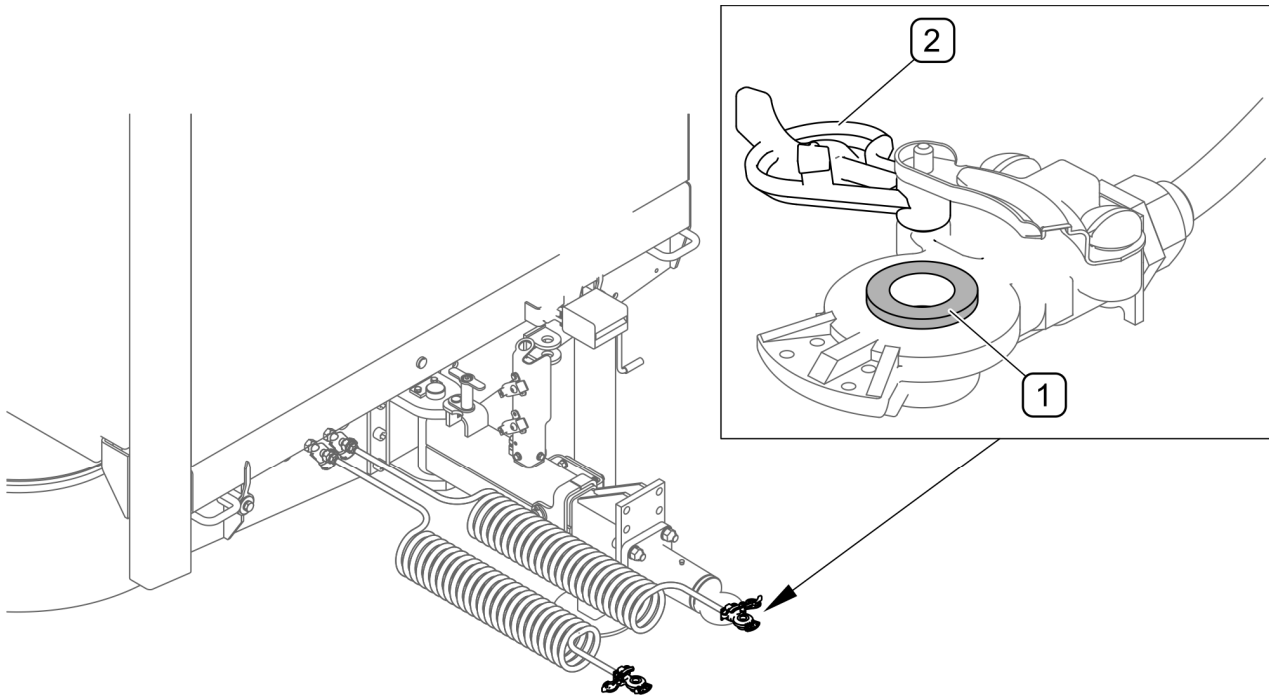

FIG. 5.27 Line connections

(1) - rubber seal; (2) - security cover

Pneumatic system connections (FIG. 5.27) must be inspected on regularly during use of machine and if necessary cleaned of all contamination. Particular attention should be paid to the technical condition of security covers (2) and rubber seals (1). If these elements are damaged they should be replaced. Contact of the seals with fuel, lubricants being petroleum derivatives, paints etc., causes rapid ageing of the material from which they are made. Before the winter period, it is recommended to preserve seal (1) with special preparations. (e.g. silicone preparations). Each time before connection of the machine inspect technical condition and cleanness of contacts and sockets in carrying vehicle. If necessary clean or repair sockets.



Connection should be inspected every time before connecting machine to carrying vehicle. During connection make sure that socket is not damaged and is maintained in the due cleanliness.

5.9 INSPECTION AND ADJUSTMENT OF WHEEL AXLE BEARINGS

In newly purchased machine, after covering a distance of 100 km, while during further use – after 6 months of vehicle use check and adjust wheel axle bearings when needed. Worn or damaged bearing should be replaced. Inspection of these elements should be conducted according to instructions below.

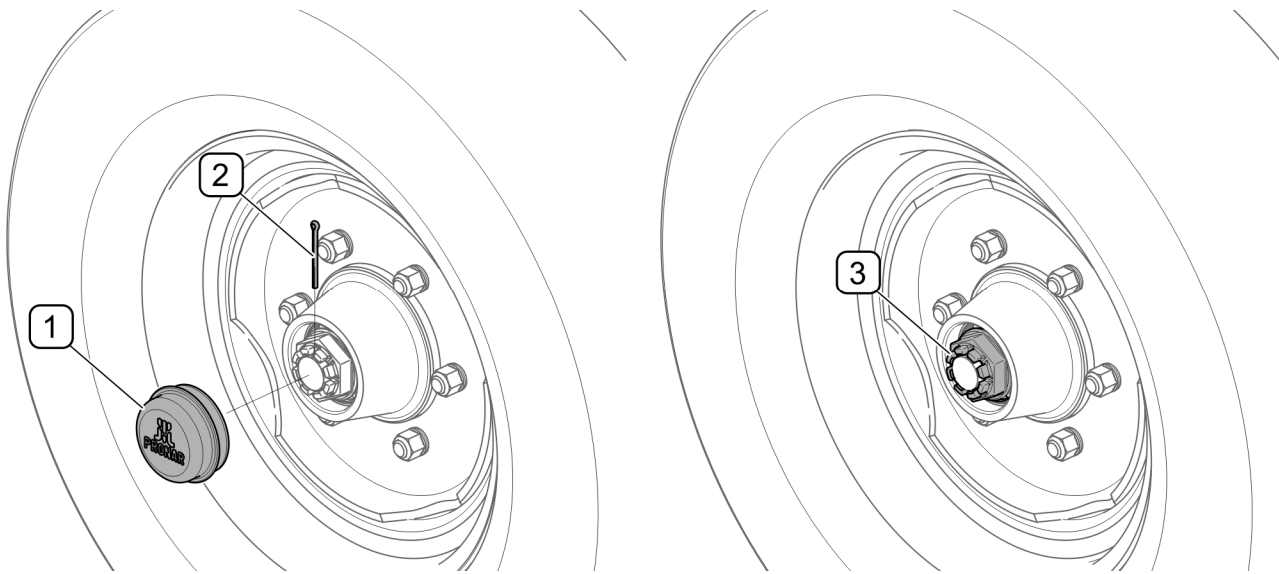

FIG. 5.28 Adjustment of wheel axle bearings

(1) - hub cover; (2) - cotter pin; (3) - castellated nut

Hitch sweeper to tractor, immobilise the tractor, place blocking chocks under sweeper wheels and raise wheels in succession using the appropriate lifting jack. The lifting jack should be placed under the axle on one side of the machine, alternately for each wheel (FIG. 5.29). Check if there is any bearing radial play. Adjustment of wheel axle bearings (FIG. 5.28) is conducted as follows:

- In the event of excessive play, disassemble hub cap (1), and remove cotter pin (2);
- Turning the wheel simultaneously tighten castellated nut (3) until the wheel comes to a stop. Unscrew nut by 1/3 rotation until the nearest cotter pin groove (2) aligns with opening in wheel stub axle
- Secure castellated nut (3) with cotter pin (2) and mount hub cap (1). The wheel should turn smoothly without faltering or detectable resistance not originating from abrasion of brake shoes in brake drum.

Inspection and adjustment of wheel axle bearings may be carried out only when the waste tank is empty.

Bearings replacement, lubrication and repairs connected with brake system and wheel axle should be entrusted to specialist service provider.



Inspection of slack and technical condition of wheel axle bearings must be performed after the first 100km of travel, and then every 6 months of machine use.

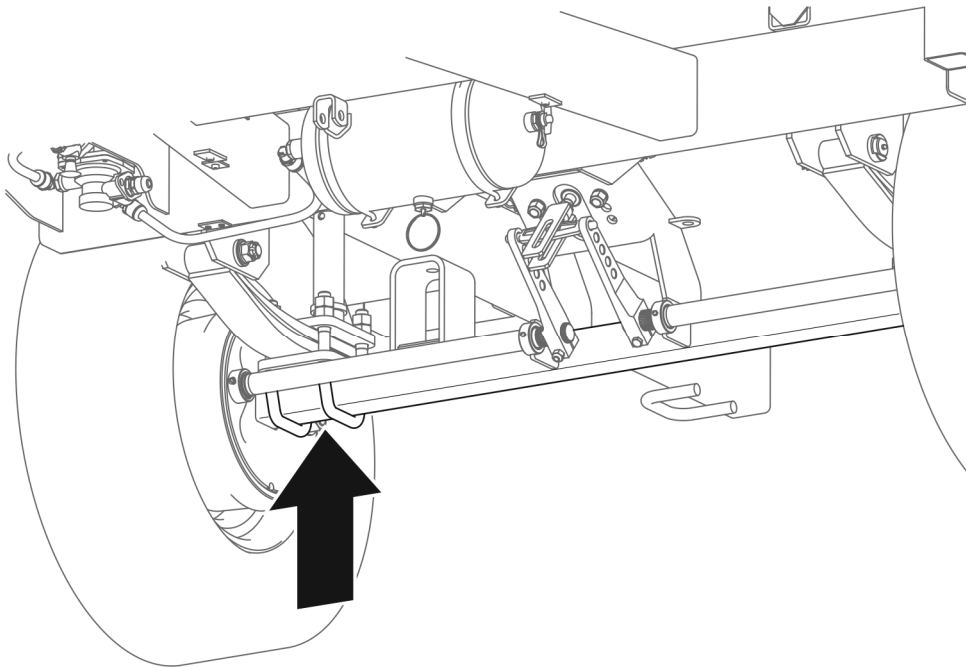

FIG. 5.29 **Lifting jack support point**

5.10 LUBRICATION

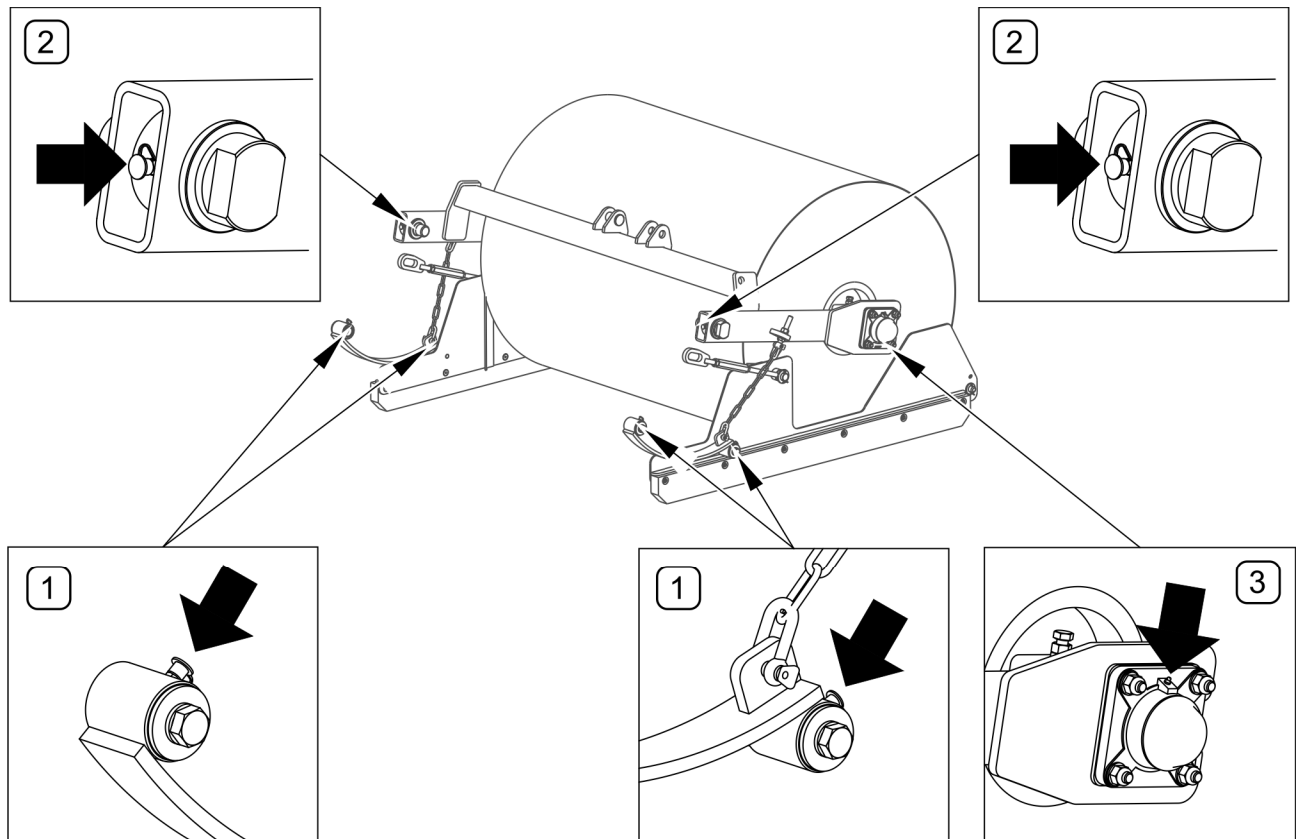

FIG. 5.30 Lubrication points of roller brush

Lubrication points are described in TAB. 5.8

TAB. 5.8 Lubrication points and lubrication frequency of roller brush

ITEM	NAME	NUMBER OF LUBRICATION POINTS	TYPE OF GREASE	LUBRICATION FREQUENCY
1	Sleeves of brush shield bracket	4	grease	25 h
2	Sleeves of brush frame	2		
3	Roller brush bearing	1		

Elevator lubrication points are shown in FIG. 5.30

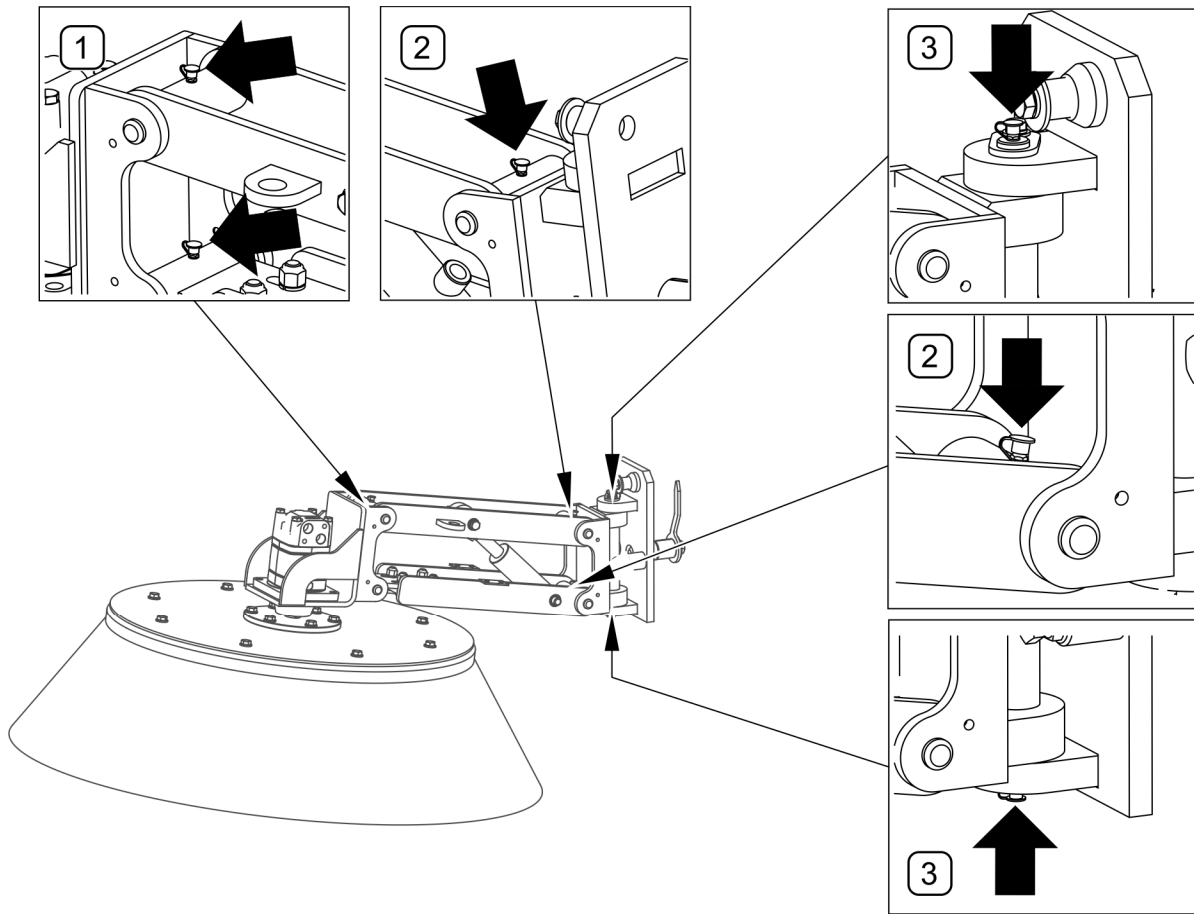

FIG. 5.31 Lubrication points of disk brushes
 (1), (2), - pins of rising mechanism; (3) - brush arm rotation pin

TAB. 5.9 Lubrication points and lubrication frequency of disk brush

ITEM	NAME	NUMBER OF LUBRICATION POINTS	TYPE OF GREASE	LUBRICATION FREQUENCY
1	Front pin of brush rising mechanism	2	grease	25 h
2	Rear pin of brush rising mechanism	2		
3	Brush arm tilt pin	2		

The above quantities of lubrication points are given for one disk brush. Lubrication points of disk brush are shown in FIG. 5.31

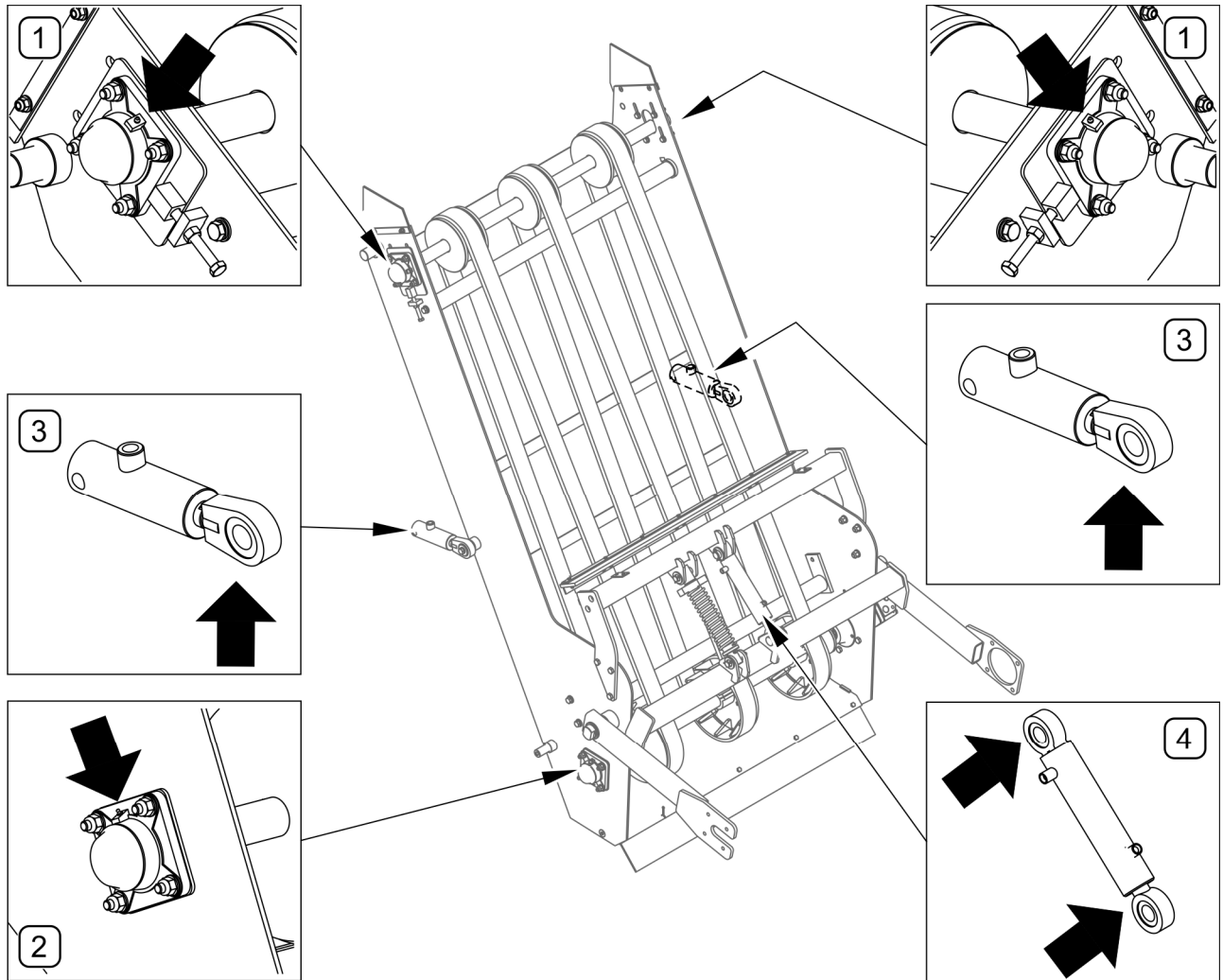

FIG. 5.32 Elevator lubrication points
 Lubrication points are described in TAB. 5.10

TAB. 5.10 Lubrication points and lubrication frequency of the elevator

ITEM	NAME	NUMBER OF LUBRICATION POINTS	TYPE OF GREASE	LUBRICATION FREQUENCY
1	Upper shaft bearing	2	grease	25 h
2	Drive shaft bearing	1		25 h
3	Elevator cylinder	2		50 h
4	Roller brush rising cylinder	2		50 h

Elevator lubrication points are shown in FIG. 5.32

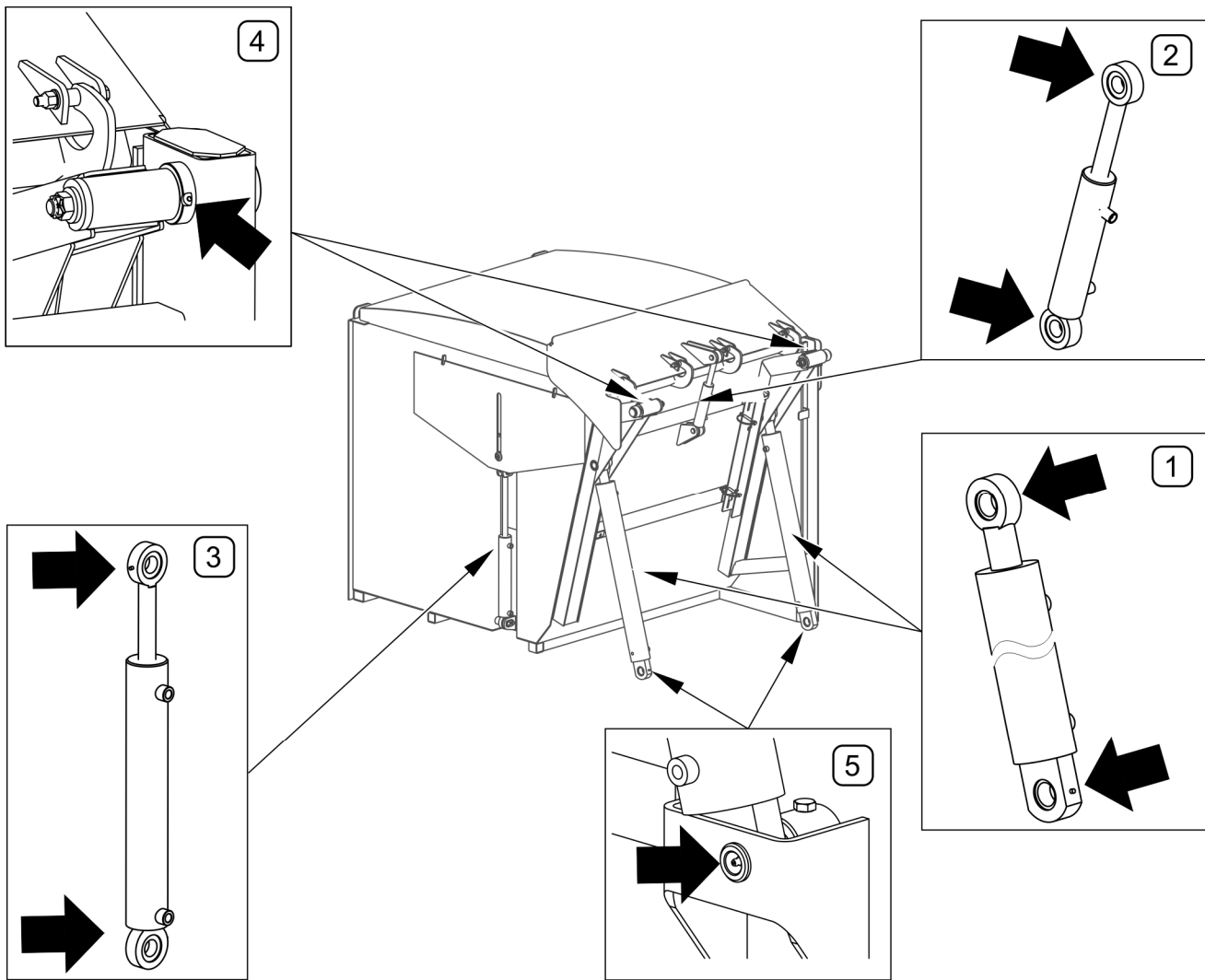

FIG. 5.33 Waste tank lubrication points

Lubrication points are described in TAB. 5.11

TAB. 5.11 Lubrication points and lubrication frequency of waste tank

ITEM	NAME	NUMBER OF LUBRICATION POINTS	TYPE OF GREASE	LUBRICATION FREQUENCY
1	Waste tank tipping cylinder	4	grease	25 h
2	Gate cylinder	2		
3	Damper cylinder	2		
4	Waste tank tipping pin	2		
5	Lower pin of waste tank tipping cylinder	2		

Waste tank lubrication points are shown in FIG. 5.33

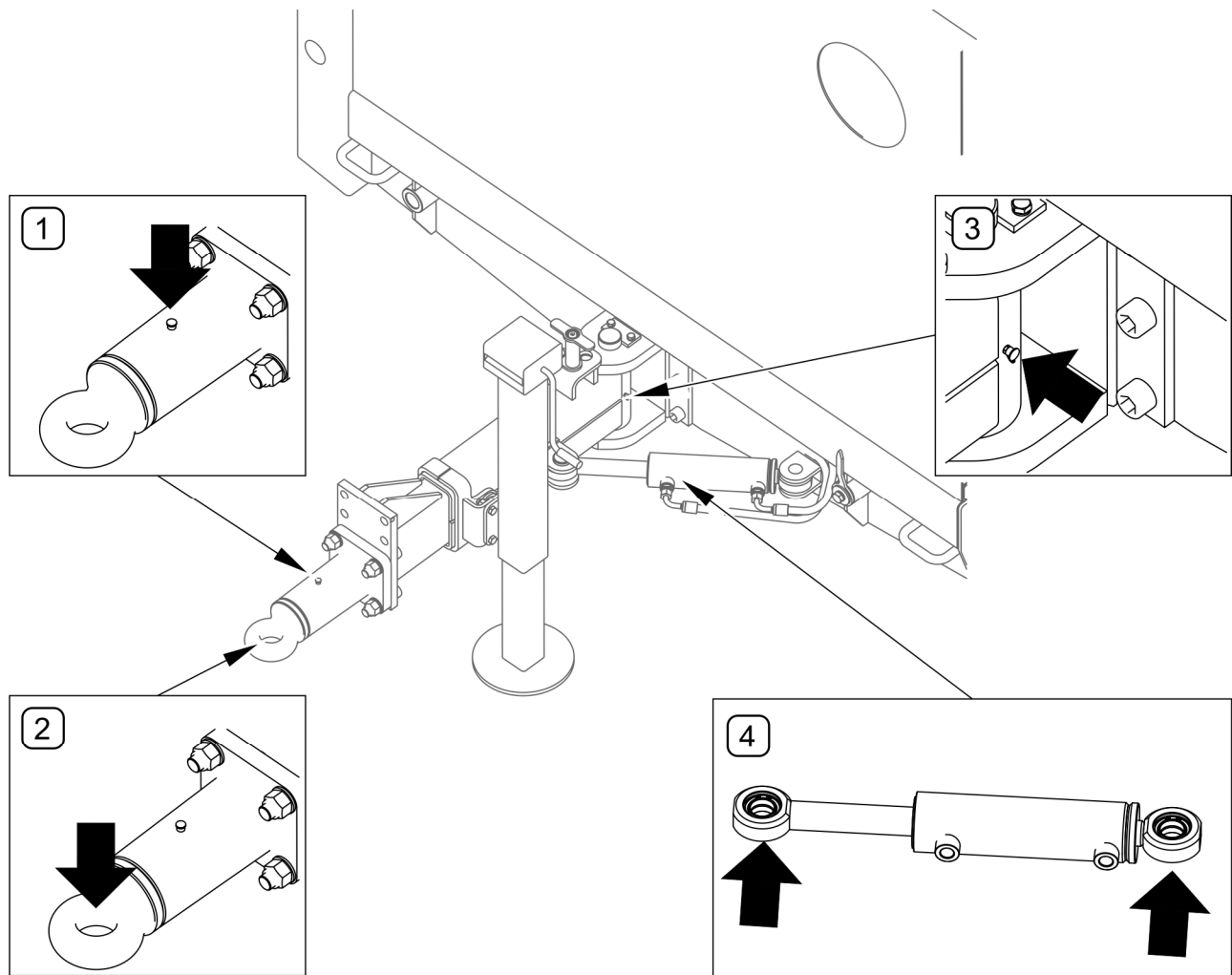

FIG. 5.34 Drawbar lubrication points

Lubrication points are described in TAB. 5.12

TAB. 5.12 Lubrication points and lubrication frequency of the drawbar

ITEM	NAME	NUMBER OF LUBRICATION POINTS	TYPE OF GREASE	LUBRICATION FREQUENCY
1	Drawbar eye turning sleeve	1	grease	50 h
2	Drawbar eye	1		
3	Drawbar turning sleeve	1		
4	Drawbar turning cylinder	2		

Drawbar lubrication points are shown in FIG. 5.34

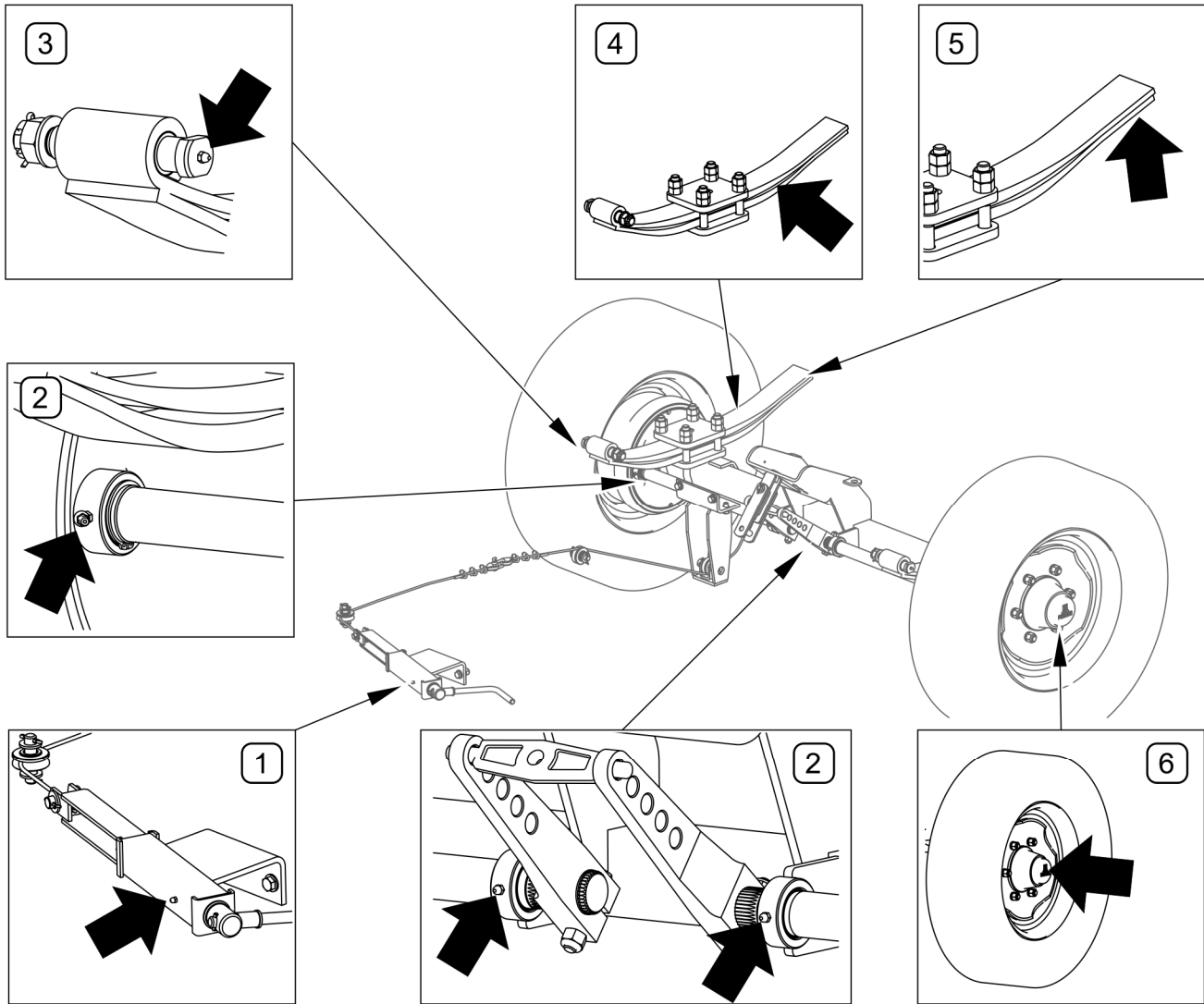

FIG. 5.35 Lubrication points of brakes and suspension

Lubrication points are described in TAB. 5.13

TAB. 5.13 Lubrication points and lubrication frequency of brakes and suspension

ITEM	NAME	NUMBER OF LUBRICATION POINTS	TYPE OF GREASE	LUBRICATION FREQUENCY
1	Parking brake mechanism	1	Grease	6 months
2	Expander shaft sleeves	4	Grease	3 months
3	Leaf spring absorber pin	2	Grease	3 months
4	Leaf spring	2	Anti-corrosion preparation in aerosol	3 months
5	Spring sliding surface	2	Grease	3 months
6	Wheel bearings	2	Grease	Replace every 2 years

Rotary rake lubrication should be performed with the aid of a manually or foot operated grease gun, filled recommended grease.

After lubricating according to instructions, wipe off excess grease.

Before beginning to grease leaf springs remove contamination, wash with water and leave to dry. Absorber plates should be lubricated using an agent having both anti-corrosion and lubricating properties, it is recommended to apply on outer leaf spring surfaces very thin layer of lithium or lime alkali grease.

Grease in wheel axle hub bearings should be replaced by specialised service points equipped with the appropriate tools.



When using the machine the user is obliged to observe lubrication instructions according to attached schedule. Excess lubrication substance causes depositing additional contaminants in places requiring lubrication, therefore it is essential to keep individual machine elements clean.

5.11 STORAGE

After finishing work, machine should be thoroughly cleaned and washed with water jet. While washing do not direct a strong water jet at information and warning decals, hydraulic or pneumatic cylinders, electrical equipment. In the event of damage to the lacquer coating clean those places from rust and dirt, degrease and then paint with paint maintaining uniform colour and even thickness of protective coating. Until the time of touch-up painting, the damaged place may be covered with a thin layer of grease or anti-corrosion preparation. Tyres should undergo conservation maintenance at least twice a year using the appropriate preparations designed for this purpose. Wheels and tyres should be previously carefully washed and dried. During longer storage of unused machine it is recommended that every 2 to 3 weeks the machine may be moved a bit so that the place of contact of tyres with ground is changed.

It is recommended to keep the machine in a closed or roofed building.

If there is a risk that temperatures drop below 0°C, drain water from the sprinkler system.

If the machine shall not be used for a long period of time, protect it against adverse weather conditions. Disconnect control panel from the machine.

The sweeper's waste tank should be empty.

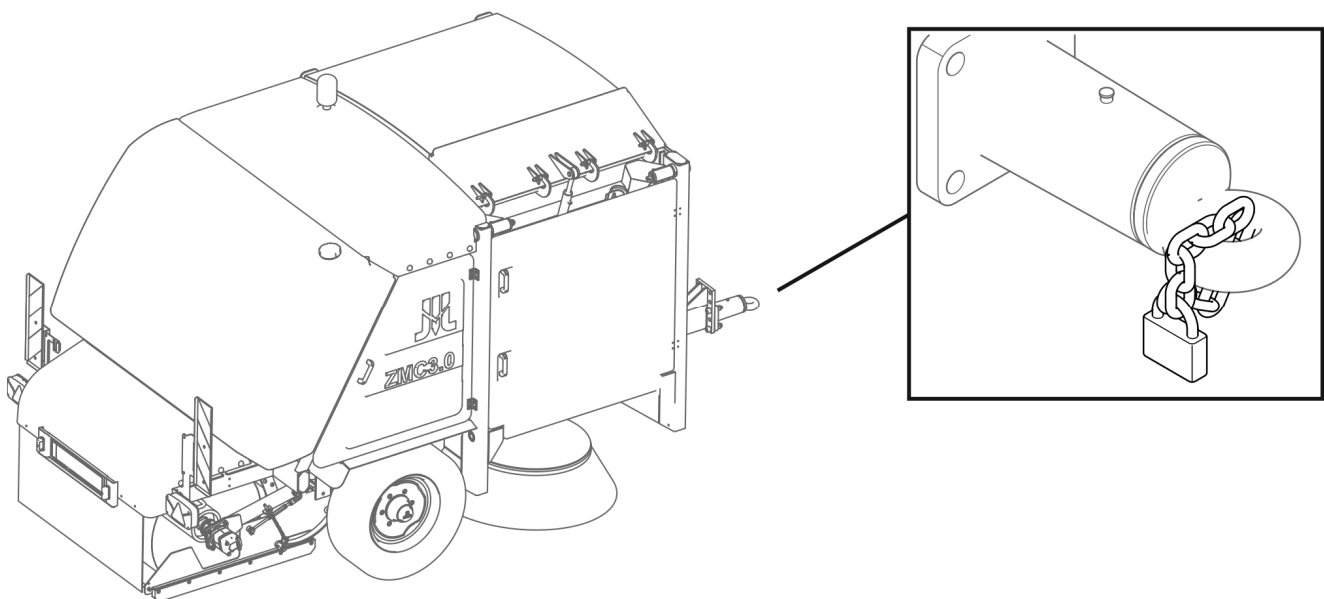

FIG. 5.37 Protecting the Machine from Unauthorized use

5.12 TIGHTENING TORQUE FOR NUT AND BOLT CONNECTIONS

Unless other tightening parameters are given, during maintenance repair work apply appropriate torque to tightening nut and bolt connections. Recommended torque values (TAB. 5.14) apply to non-greased steel bolts.

TAB. 5.14 TIGHTENING TORQUE FOR NUT AND BOLT CONNECTIONS

THREAD DIAMETER [mm]	5.8	8.8	10.9
	TIGHTENING TORQUE [Nm]		
M6	8	10	15
M8	18	25	36
M10	37	49	72
M12	64	85	125
M14	100	135	200
M16	160	210	310
M20	300	425	610
M24	530	730	1050
M27	820	1150	1650
M32	1050	1450	2100

NOTES

A series of horizontal dotted lines for writing notes.