



**PRONAR Sp. z o.o.**

17-210 NAREW, UL. MICKIEWICZA 101A, PODLASKIE PROVINCE

phone:	+48 085 681 63 29	+48 085 681 64 29
	+48 085 681 63 81	+48 085 681 63 82
fax:	+48 085 681 63 83	+48 085 682 71 10

[www.pronar.pl](http://www.pronar.pl)

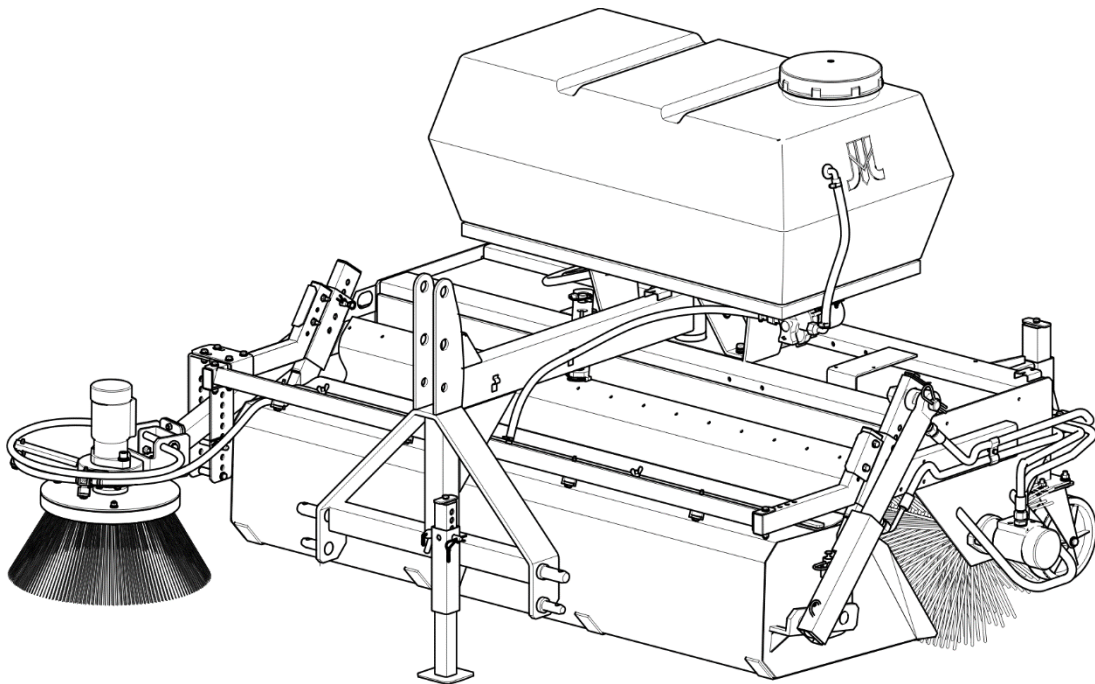
# OPERATOR`S MANUAL

## MOUNTED SWEEPER

### PRONAR „Agata”

## PRONAR ZM-1250

TRANSLATION OF THE ORIGINAL COPY OF THE MANUAL



EDITION 1B-05-2016

PUBLICATION NO. 472N-0000000-UM





**MOUNTED SWEEPER  
PRONAR „Agata”**

**ZM-1250**

**MACHINE IDENTIFICATION**

**TYPE:**

**SERIAL NUMBER:**

--	--	--	--	--	--

# INTRODUCTION

Information contained herein is current at date of publication. As a result of improvements, some numerical values and illustrations contained in this publication may not correspond to the factual specification of the machine supplied to the user. The manufacturer reserves the right to introduce design changes in machines produced that facilitate operation and improve the quality of their work, without making minor amendments to this Operator's Manual.

This Operator's Manual is an integral part of the machine's documentation. Before using the machine, the user must carefully read this Operator's Manual and observe all recommendations. This guarantees safe operation and ensures failure-free work of the machine. The machine is designed to meet obligatory standards, documents and legal regulations currently in force.

The manual describes the basic safety rules and operation of the sweeper. If the information stated in the Operator's Manual needs clarification then the user should refer for assistance to the sale point where the machine was purchased or to the Manufacturer.

## MANUFACTURER'S ADDRESS:

*PRONAR Sp. z o.o.  
ul. Mickiewicza 101A  
17-210 Narew*

## CONTACT TELEPHONES

*+48 085 681 63 29*

*+48 085 681 64 29*

*+48 085 681 63 81*

*+48 085 681 63 82*

## SYMBOLS APPEARING IN THIS OPERATOR'S MANUAL

Information, descriptions of danger and precautions and also recommendations and prohibitions associated with user safety instructions are marked:



and also preceded by the word "**DANGER**". Failure to observe the instructions may endanger the machine operator's or other person's health or life.

Particularly important information and instructions, the observance of which is essential, are distinguished in the text by the sign:



and also preceded by the word "**ATTENTION**". Failure to observe the instructions may lead to damage to the machine as a result of improper operation, adjustment or use.

In order to focus the user's attention on the need to perform maintenance, the relevant section of the Operator's Manual is marked with the pictogram:



Additional tips and advice for machine operation are marked with the sign:



and also preceded by the word "**TIP**".

## DIRECTIONS USED IN THIS OPERATOR'S MANUAL

Left side – side to the left hand of the operator facing in the direction of machine's forward travel.

Right side – side to the right hand of the operator facing in the direction of machine's forward travel.



**PRONAR Sp. z o.o.**

ul. Mickiewicza 101 A

17-210 Narew, Polska

tel./fax (+48 85) 681 63 29, 681 63 81, 681 63 82,  
681 63 84, 681 64 29

fax (+48 85) 681 63 83

http://www.pronar.pl

e-mail: pronar@pronar.pl

## EC DECLARATION OF CONFORMITY OF THE MACHINERY

PRONAR Sp. z o.o. declares with full responsibility, that the machine:

Description and identification of the machinery	
Generic denomination and function:	<b>Tractor attached sweeper</b>
Type:	<b>ZM-1250</b>
Model:	—
Serial number:	
Commercial name:	<b>Tractor attached sweeper PRONAR Agata ZM-1250</b>

to which this declaration relates, fulfills all the relevant provisions of the Directive **2006/42/EC** of The European Parliament and of The Council of 17 May 2006 on machinery, and amending Directive 95/16/EC (Official Journal of the EU, L 157/24 of 09.06.2006).

The person authorized to compile the technical file is the Head of Research and Development Department at PRONAR Sp. z o.o., 17-210 Narew, ul. Mickiewicza 101A, Poland.

This declaration relates exclusively to the machinery in the state in which it was placed on the market, and excludes components which are added and/or operations carried out subsequently by the final user.

Narew, the 2016-05-19

*Place and date*

**"PRONAR"**  
Spółka z o.o.  
17-210 Narew, ul. Mickiewicza 101 A  
tel. (085) 681 6329, 681 6429  
fax. (085) 681 6383

Z-CIA DYREKTORA  
d/s technicznych  
członkowie zarządu

*Roman Orzechaniuk*

*Full name of the empowered person  
position, signature*

# TABLE OF CONTENTS

<b>1</b>	<b>BASIC INFORMATION</b>	<b>1.1</b>
1.1	IDENTIFICATION	1.2
1.2	PROPER USE	1.3
1.3	ACCESSORIES	1.5
1.4	TERMS & CONDITIONS OF WARRANTY	1.6
1.5	TRANSPORT	1.7
1.6	ENVIRONMENTAL HAZARDS	1.10
1.7	WITHDRAWAL FROM USE	1.10
<b>2</b>	<b>SAFETY ADVICE</b>	<b>2.1</b>
2.1	BASIC SAFETY RULES	2.2
2.1.1	USE OF MACHINE	2.2
2.1.2	HITCHING AND UNHITCHING FROM CARRYING VEHICLE	2.3
2.1.3	HYDRAULIC SYSTEM	2.3
2.1.4	TRANSPORTING THE MACHINE	2.4
2.1.5	MAINTENANCE	2.5
2.1.6	MACHINE OPERATION	2.6
2.2	RESIDUAL RISK	2.7
2.3	INFORMATION AND WARNING DECALS	2.8
<b>3</b>	<b>DESIGN AND OPERATION</b>	<b>3.1</b>
3.1	TECHNICAL SPECIFICATION	3.2
3.2	GENERAL DESIGN	3.4
3.3	HYDRAULIC SYSTEM	3.5
3.4	SPRINKLER SYSTEM	3.9
3.5	ELECTRICAL SYSTEM	3.10

<b>4</b>	<b>CORRECT USE</b>	<b>4.1</b>
4.1	PREPARING FOR WORK	4.2
4.2	CHECKING TECHNICAL CONDITION	4.4
4.3	HITCHING TO CARRYING VEHICLE	4.5
4.4	SWEEPER OPERATION	4.8
4.4.1	FILLING THE SPRINKLER SYSTEM TANK	4.8
4.4.2	SPRINKLER SYSTEM CONTROL	4.9
4.4.3	EMPTYING THE WASTE TANK	4.9
4.4.4	ADAPTING THE SWEEPER FOR OPERATION IN FRONT OF THE CARRYING VEHICLE.	4.10
4.4.5	ADAPTING THE SWEEPER FOR OPERATION WITHOUT THE WASTE TANK	4.12
4.4.6	CHANGING THE SWEEPER'S WORKING ANGLE	4.14
4.5	DRIVING ON PUBLIC ROADS	4.15
4.6	UNHITCHING THE MACHINE FROM THE CARRYING VEHICLE	4.17
<b>5</b>	<b>MAINTENANCE</b>	<b>5.1</b>
5.1	ADJUSTMENT OF ROLLER BRUSH	5.2
5.2	ADJUSTING THE WASTE TANK	5.3
5.3	ADJUSTING THE SIDE BRUSH	5.5
5.4	INSPECTION AND REPLACEMENT OF ROLLER BRUSH	5.9
5.5	REPLACING THE SIDE BRUSH	5.10
5.6	SPRINKLER SYSTEM MAINTENANCE	5.11
5.7	HYDRAULIC SYSTEM OPERATION	5.13
5.8	ELECTRICAL SYSTEM MAINTENANCE	5.15
5.9	LUBRICATION	5.16
5.10	STORAGE	5.17
5.11	TIGHTENING TORQUE FOR NUT AND BOLT CONNECTIONS	5.18
5.12	TROUBLESHOOTING	5.19



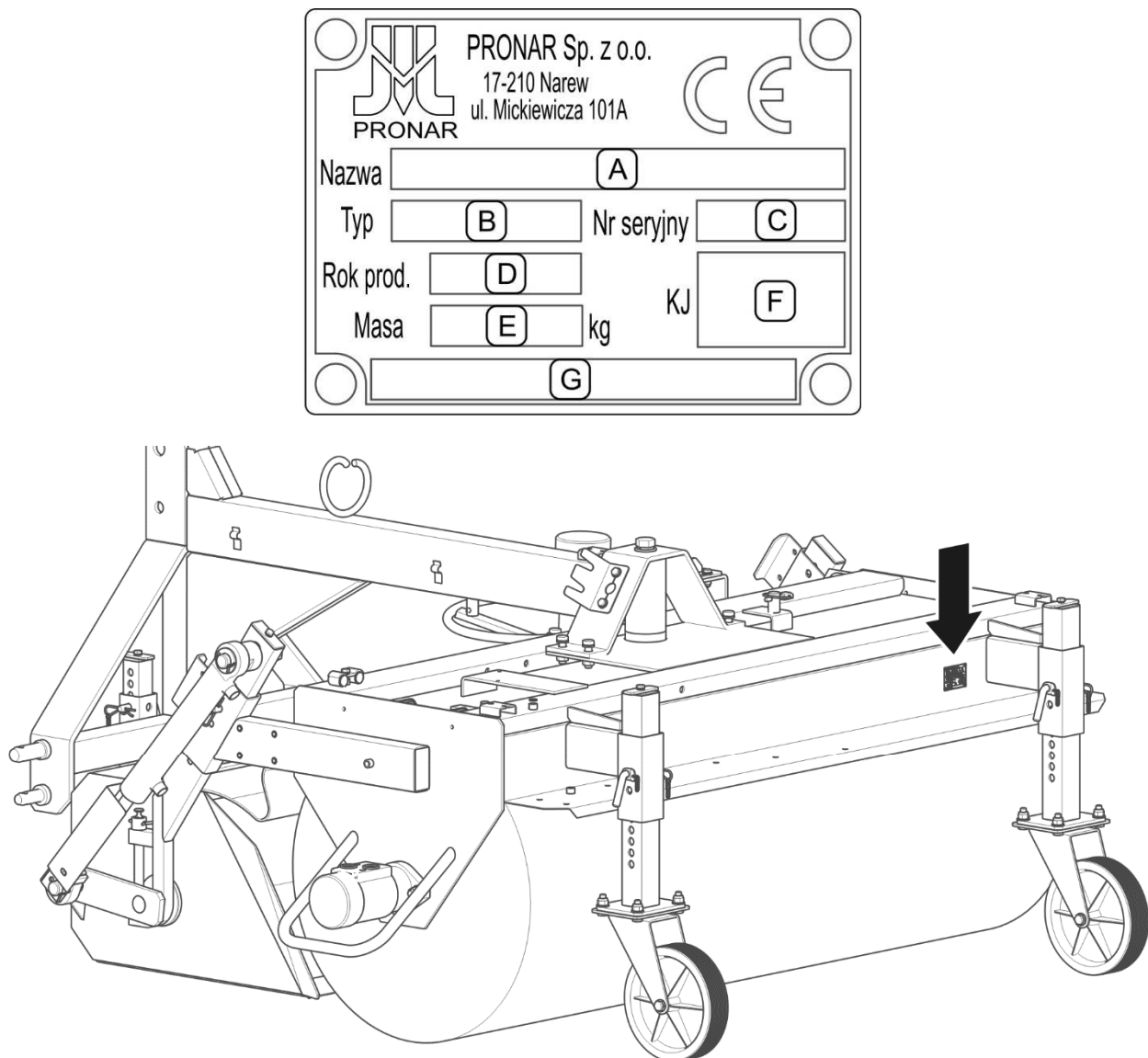
*SECTION*

**1**

---

**BASIC INFORMATION**

## 1.1 IDENTIFICATION



**FIGURE 1.1** Location of the data plate

Meaning of data plate items (FIGURE 1.1):

- A - machine name
- B – type
- C – serial number
- D – year of manufacture
- E – machine tare weight [kg]
- F – Quality Control stamp
- G – additional information

Serial number is stamped on the data plate. The sweeper's data plate is located next to the right bracket of the jockey wheel. (FIGURE 1.1).

When buying the machine, confirm that the serial number on the machine corresponds to the number indicated in the *WARRANTY BOOK*, in the sales documents and in the *OPERATOR'S MANUAL*.

## 1.2 PROPER USE

The ZM-1250 mounted sweeper is used for keeping clean access roads, squares, parking spaces, extensive warehouse areas, external surroundings of buildings with paved surfaces as asphalt, concrete paving blocks, concrete. The sweeper may be used by road maintenance services for technological cleaning of the roadbed prior to application of asphalt layer on renovated road sections. Without the waste tank the sweeper can be used for clearing of dirt or a thin, fresh layer of snow on the right or left without actually collecting the swept materials.


Depending on its equipment, the sweeper can be mounted on carrying vehicles that meet the requirements set out in table 1.1.

Using it as intended also involves all actions connected with the safe and proper operation and maintenance of the machine. Due to the above, the user is obliged to:

- carefully read the *OPERATOR'S MANUAL* and comply with its recommendations,
- understand the machine's operating principle and how to operate it safely and correctly,
- comply with general safety regulations while working,
- prevent accidents,
- comply with road traffic regulations.

The machine may only be used by persons, who:

- are familiar with the contents of this publication and with the contents of the carrying vehicle's Operator's Manual,
- have been trained in machine operation and safe working conditions,
- have the required authorisation to drive the vehicle and are familiar with the road traffic regulations and transport regulations.

	<p><b>ATTENTION</b></p> <p>The machine must not be used for purposes other than those for which it is intended, in particular for:</p> <ul style="list-style-type: none"> <li>• for transporting people and animals,</li> <li>• for transport of whatever objects on the machine</li> </ul>
---	---

**TABLE 1.1 Agricultural tractor (carrying vehicle) requirements**

	UNIT	REQUIREMENTS
<b>Hydraulic system</b>		
Nominal pressure	MPa	16 – 20*
Type of oil	-	hydraulic, HL32
Number and type of hydraulic connectors	-	2 sockets type 12,5-ISO 7241-1-serie-A of one section with lockable ON position and the option to change the oil flow direction
Capacity of the system	l/min	13-25*
<b>Electrical system</b> <i>(for sprinkler system and lighting system)</i>		
Lighting system socket	-	7 polar compliant with ISO 1724
Electrical system voltage	V	12
<b>Other requirements</b>		
Mounting method	-	compatible with the sweeper's mounting system
Equipment of carrying vehicle	-	beacon light <i>(orange light)</i>

\* - optimum values are given; declared performance and durability of the machine are not guaranteed for other values

## 1.3 ACCESSORIES

### The sweeper equipment includes:

- Operator's Manual,
- Warranty Book,
- roller brush to choose from:
  - very hard brush (*plastic 2x3 mm + wire 0.5 mm*)
  - hard (*plastic 1.6 mm + wire 0.5 mm*)
  - medium (*plastic 2x3 mm*)
  - soft (*plastic 1.6 mm*)
- sprinkler system

### Additional fittings and optional equipment:

- side brush to choose from:
  - hard (*flat wire*)
  - medium (*flat wire +plastic 2x3 mm*)
  - soft (*plastic 2x3 mm*)
- pins of category II,
- linkages,
- without waste tank
- front jockey wheel (*part number 12N-22000000*),
- electrical system with lights depending on the machine version:
  - rear-mounted sweeper with/without sprinkler system (*part number 12N-32030000-01*),
  - front-mounted sweeper with sprinkler system (*part number 12N-32030000-03*),
  - front-mounted sweeper without sprinkler system (*part number 12N-32030000-04*),
- bracket for the warning sign (*part number 12N-31000000*)
- reinforced wheels

Mounting versions:

- for the carrying vehicle's rear
- for the carrying vehicle's front

## 1.4 TERMS & CONDITIONS OF WARRANTY

PRONAR Sp. z o.o. Narew guarantees the reliable operation of the machine when it is used according to its intended purpose as described in the *OPERATOR'S MANUAL*. Defects discovered during the warranty period will be removed by the Warranty Service. The repair period is specified in the *WARRANTY BOOK*.

The guarantee does not apply to those parts and sub-assemblies of the machine, which are subject to wear in normal usage conditions, regardless of the warranty period. Consumables include the following parts/sub-assemblies:

- working elements of the roller brush and side brush,
- jockey wheels,
- protective coatings in contact with contaminations, brush bristle and hitching points,
- bearings, filters, bulbs

The warranty service only applies to factory defects and mechanical damage that is not due to the user's fault.

In the event of damage arising from:

- mechanical damage which is the user's fault, road accidents,
- incorrect use, adjustment or maintenance, use of the machine for purposes other than those for which it is intended,
- use of damaged or malfunctioning machine,
- repairs carried out by unauthorised persons, repairs carried out improperly,
- making unauthorised alterations to machine design,

the user will lose the right to warranty service.

**TIP**

Demand that the seller carefully and precisely fills out the **WARRANTY BOOK** and guarantee repair coupons. A missing date of purchase or sale point stamp, may make the user ineligible for any warranty repair or refund.

The user is obliged to report immediately on noticing any wear in the paint coating or traces of corrosion, and to have the faults rectified whether they are covered by the guarantee or not. For detailed Terms & Conditions of Warranty, please refer to the **WARRANTY BOOK** attached to each newly purchased machine.

Modification of the machine without the written consent of the Manufacturer is forbidden. In particular, do NOT weld, drill holes in, cut or heat the main structural elements, which have a direct impact on the machine operation safety.

## 1.5 TRANSPORT

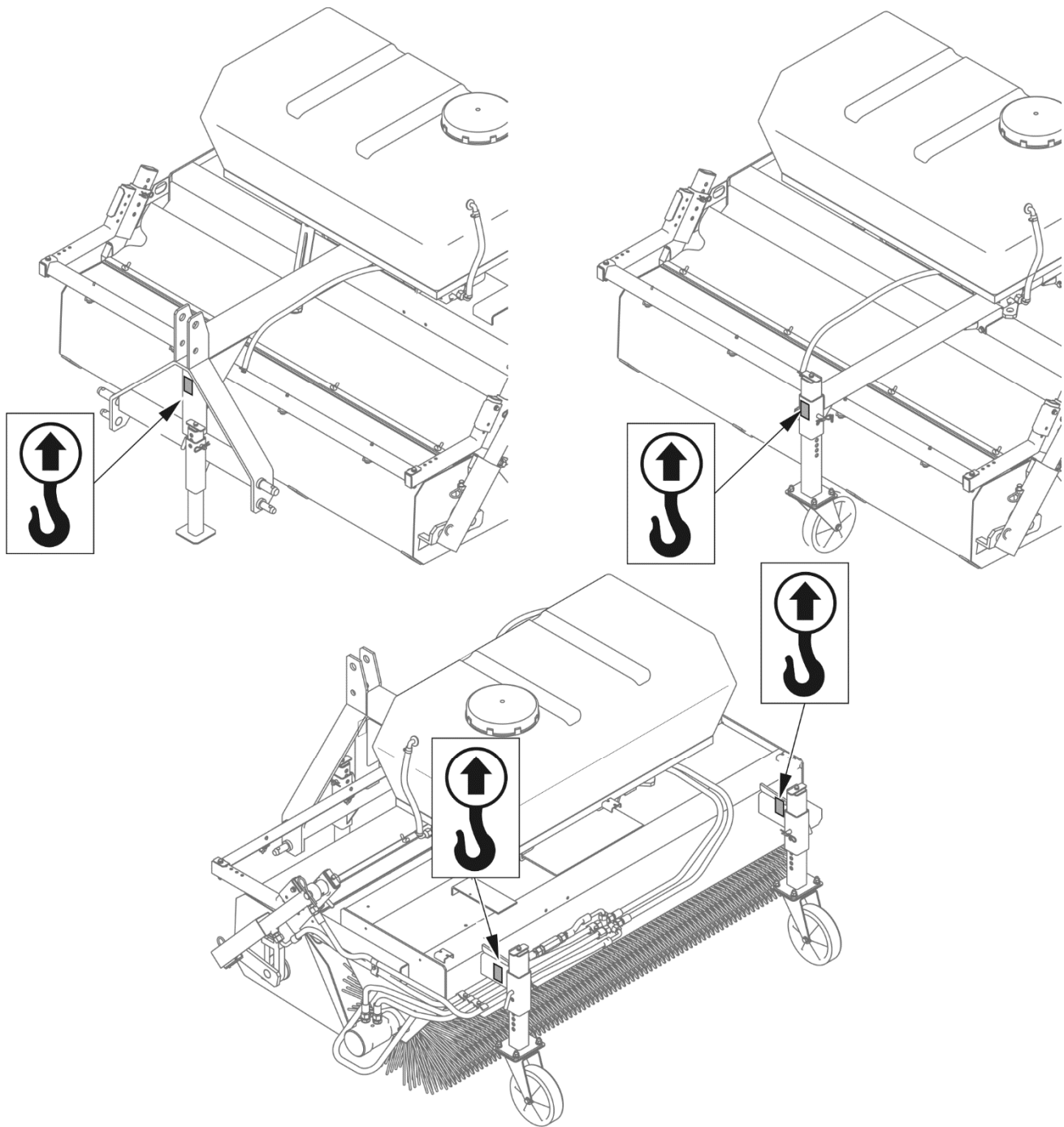
The machine is prepared for sale completely assembled and does not require packing. Packing is only required for the machine operator's manual and electrical system components.

Delivery is either by transport on a vehicle or independently, after being attached to a tractor. Transport of the machine is permissible connected to a carrying vehicle provided the vehicle's driver familiarises himself with the machine's Operator's Manual and particularly with information concerning safety and principles of connection and transport on public roads.

During road transport the machine should be firmly secured on the load platform by means of certified belts or chains fitted with a tightening mechanism.

When loading and unloading the machine, comply with the general principles of workplace health and safety for reloading work. Persons operating reloading equipment must have the qualifications required to operate these machines.

The machine should be attached to lifting equipment in places specially designed for this purpose (FIGURE 1.2), i.e. by the linkage bracket and by each of the jockey wheel brackets. In the front-mounted sweeper, the additional suspension point is located on the bracket of the front jockey wheel.



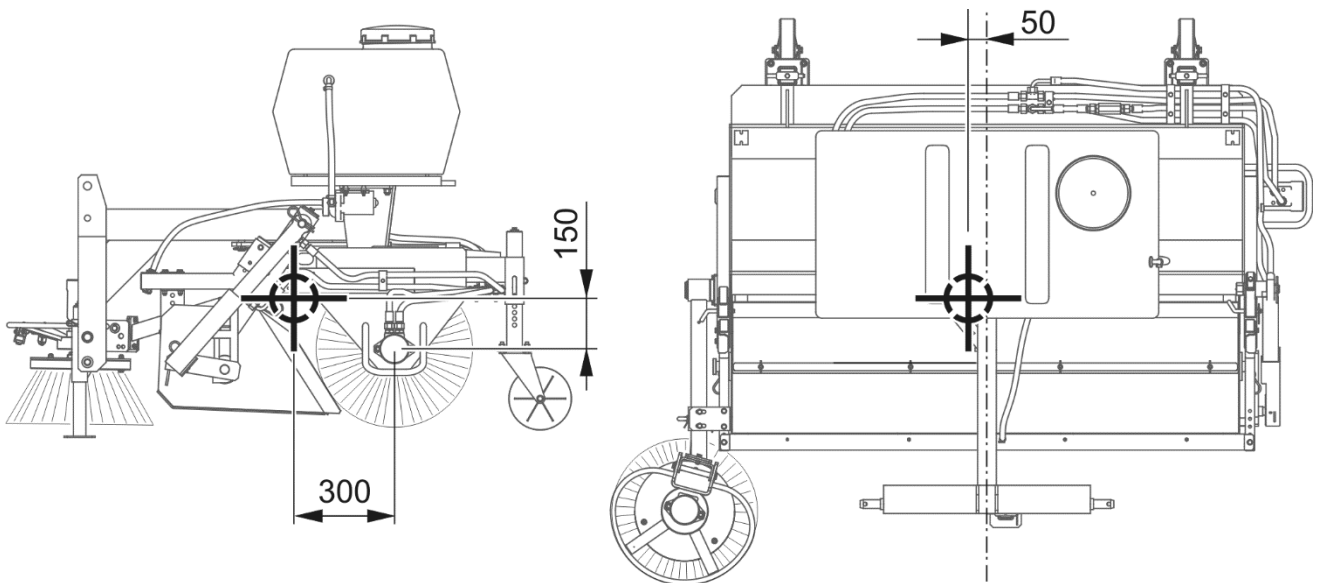
**FIGURE 1.2** Transport suspension points

Suspension points are identified with information decals. When lifting the machine take particular care due to the possibility of tipping over the machine and the risk of injuries from protruding parts. To keep lifted machine in the correct direction it is recommended to apply additional guy cables. During the loading work particular care should be taken not to damage paint coating.



**DANGER**

When transporting independently, the user must carefully read this Operator's Manual and observe all recommendations. When being transported on a motor vehicle the machine must be mounted on the vehicle's platform in accordance with the transport safety requirements. The driver of the vehicle should take particular care while transporting the machine. This is due to the vehicle's centre of gravity shifting upwards when loaded with the machine.



**FIGURE 1.3** Centre of gravity

*Dimensions on the drawing are given in millimetres [mm] for the rear-mounted sweeper equipped with a side brush and sprinkler system with empty water tank.*

**NOTE**

Depending on the machine version, location of centre of gravity varies in the range of  $\pm 50$  mm

**NOTE**

Do NOT secure lifting slings or any types of load securing elements to hydraulic cylinders, electrical system components and fragile elements of the machine (e.g. shields, conduits).

## 1.6 ENVIRONMENTAL HAZARDS

A hydraulic oil leak constitutes a direct threat to the natural environment owing to its limited biodegradability. Maintenance and repair work which involves the risk of an oil leak should be performed in the rooms with oil resistant surface. In the event of oil leaking into the environment, first of all contain the source of the leak, and then collect the leaked oil using available means. Remaining oil should be collected using sorbents, or by mixing the oil with sand, sawdust or other absorbent materials. The oil contaminations, once gathered up, should be kept in a sealed, marked, hydrocarbon resistant container, and then passed on to the appropriate oil waste recycling centre. The container should be kept away from heat sources, flammable materials and food.

Oil, which has been used up or is unsuitable for further use owing to a loss of its properties should be stored in its original packaging in the conditions described above.

## 1.7 WITHDRAWAL FROM USE

In the event of decision by the user to withdraw the machine from use, comply with the regulations in force in the given country concerning withdrawal from use and recycling of machines withdrawn from use.



### **ATTENTION**

**During dismantling, personal protection equipment shall be used i.e. protective clothing, boots, gloves and protective goggles etc.**

**Avoid contact of skin with oil. Do not allow used oil to spill.**

In the event of decision by the user to withdraw the machine from use, comply with the regulations in force in the given country concerning withdrawal from use and recycling of machines withdrawn from use.

Before proceeding to dismantle machine, oil shall be completely removed from hydraulic system.

When spare parts are changed, worn out or damaged parts should be taken to a collection point for recyclable raw materials. Used oil and also rubber and plastic elements should be taken to the appropriate facilities dealing with the recycling of this type of waste.

**SECTION**

**2**

---

**SAFETY ADVICE**

## 2.1 BASIC SAFETY RULES

### 2.1.1 USE OF MACHINE

- Before using the machine, the user must carefully read this Operator's Manual and the *WARRANTY BOOK*. When operating the machine, the operator must comply with all recommendations contained in the Operator's Manual.
- The machine may only be used and operated by persons qualified to drive carrying vehicles and trained in the use of the machine.
- If the information in this Operator's Manual is difficult to understand, contact the dealer, who runs an manufacturer authorised service, or contact the manufacturer directly.
- Careless and incorrect use and operation of the machine, and non-compliance with the recommendations given in this Operator's Manual is dangerous to your health.
- Be aware of the existence of a residual risk, and for this reason the fundamental basis for using this machine should be the application of safety rules and sensible behaviour.
- The machine must never be used by persons, who are not authorised to drive carrying vehicle, including children and people under the influence of alcohol or other drugs.
- The machine must not be used for purposes other than those for which it is intended. Anyone who uses the machine other than the way intended takes full responsibility for himself for any consequences of this use. Use of the machine for purposes other than those for which it is intended by the Manufacturer may invalidate the guarantee.
- The machine may only be used when all the protective elements (e.g. shields) and warning markings are technically sound and correctly positioned. In the event of loss or destruction of the protective elements, they must be replaced with new ones.

### **2.1.2 HITCHING AND UNHITCHING FROM CARRYING VEHICLE**

- Do NOT hitch the machine to a carrying vehicle, if the linkage system of the machine is not compatible with the linkage system of the carrying vehicle.
- After completed hitching of the machine, check the safeguards. Carefully read the carrying vehicle Operator's Manual.
- To hitch the machine to the carrying vehicle use only the linking elements recommended by the machine Manufacturer.
- The carrying vehicle to which the machine will be hitched must be technically reliable and must fulfil the requirements specified by the machine Manufacturer.
- Be especially careful when hitching the machine to carrying vehicle.
- When hitching, there must be nobody between the machine and the carrying vehicle.
- Be especially careful when unhitching the machine from the carrying vehicle.
- The machine disconnected from the carrying vehicle must be supported on wheels and/or parking stand and placed on level, sufficiently hard surface in such a manner as to ensure that it is possible to connect it again.

### **2.1.3 HYDRAULIC SYSTEM**

- The hydraulic system is under high pressure when operating.
- Regularly check the technical condition of the connections and the hydraulic conduits. There must be no oil leaks.
- In the event of the hydraulic system malfunction, discontinue using the machine until the malfunction is corrected.
- When connecting or disconnecting the hydraulic conduits, make sure that carrying vehicle and machine hydraulic system is not under pressure. If necessary, reduce residual pressure in the system.
- Use the hydraulic oil recommended by the Manufacturer. Never mix two types of oil.
- In the event of injuries being caused by pressurised hydraulic oil, contact a doctor immediately. Hydraulic oil may find its way under the skin and cause infections. In

the event of contact of oil with eye, rinse with large quantity of water and in the event of the occurrence of irritation consult a doctor. In the event of contact of oil with skin wash the area of contact with water and soap. Do NOT apply organic solvents (petrol, kerosene).

- Used oil or oil which has lost its properties should be stored in original containers or replacement containers resistant to action of hydrocarbons. Replacement containers must be clearly marked and appropriately stored.
- Do not store hydraulic oil in packaging designed for storing food or foodstuffs.
- Hydraulic conduits must be changed every 4 years regardless of their technical condition.
- Repair and replacement of hydraulic system elements should be entrusted to the appropriately qualified persons.

#### **2.1.4 TRANSPORTING THE MACHINE**

- Before driving on public roads, check operation of indicator lights.
- When driving on public roads, comply with the road traffic regulations in force in the country, in which the machine is used.
- Do not exceed the permitted speed arising from road conditions and design limitations. Adjust travel speed to the existing road conditions and other limitations arising from road traffic regulations limits.
- Do NOT leave the machine raised and unsecured while the carrying vehicle is parked. When parked, the machine should be lowered.
- Do NOT ride on the machine or transport any materials on it.
- Before using the machine always check its technical condition, especially in terms of safety. In particular, check technical condition of linkage and connecting elements of hydraulic system.
- When driving with raised machine, the carrying vehicle's linkage should be locked in the up position to prevent its accidental lowering (*if it is possible*)
- Reckless driving and excessive speed may cause accidents.

### 2.1.5 MAINTENANCE

- During the warranty period, any repairs may only be carried out by Warranty Service authorised by the manufacturer. It is recommended that necessary repairs to machine should be undertaken by specialised workshops.
- In the event of any fault or damage, do not use the machine until the fault has been corrected.
- During work, use the proper, close-fitting protective clothing, gloves and appropriate tools. When working on hydraulic systems it is recommended to use oil resistant gloves and protective goggles.
- Any modification to the machine frees PRONAR from any responsibility for damage or detriment to health which may arise as a result.
- Regularly check the technical condition of the safety devices and correct tightening of bolt connections.
- Regularly perform service inspections of machine as recommended by the Manufacturer.
- Servicing and repair work should be carried out in line with the general principles of workplace health and safety. In the event of injury, the wound must be immediately cleaned and disinfected. In the event of more serious injuries, seek a doctor's advice.
- Repair, maintenance and cleaning work should be carried out with the carrying vehicle's engine turned off and the ignition key removed. Immobilise the carrying vehicle with parking brake and ensure that unauthorised persons do not have access to the vehicle's cab.
- Should it be necessary to change individual parts, use only original parts. Non-adherence to these requirements may put the user and other people's health and life at risk, and also damage the machine and invalidate the warranty.
- Regularly check technical condition and mounting of all guards and protective elements.
- Do NOT weld, drill holes in, cut or heat the main structural elements, which have a direct impact on the machine operation safety.

- In the event of work requiring the machine to be raised, use properly certified hoists or lifting devices. After lifting the machine, stable and durable supports must also be used. Do NOT perform service or repair work under raised and unsupported machine.
- The machine must not be supported using fragile elements (bricks or concrete blocks).
- After completing work associated with lubrication, remove excess oil or grease.
- In order to reduce the danger of fire the machine must be kept in a clean condition.

### **2.1.6 MACHINE OPERATION**

- Before starting the carrying vehicle with the hitched machine, make sure that the control levers of the external hydraulic system are not engaged, otherwise, the machine may be started in an uncontrolled manner.
- Before activating the machine, always ensure that all the safety guards are in good condition and in place.
- Before lifting or lowering the machine mounted on the carrying vehicle, make sure that there are no bystanders near the machine.
- Before starting the machine make sure that there are no bystanders (especially children) or animals in the danger zone. The operator is obliged to ensure proper visibility of the machine and the working area.
- During machine operation do not occupy a different position than that of the operator in the vehicle's cab. Do NOT leave the cab, when the machine is in operation.
- Keep a safe distance from rotating parts of the machine.
- When filling the water tank, the machine should be lowered to working position and the carrying vehicle's engine should be turned off.



## 2.2 RESIDUAL RISK

Pronar Sp. z o. o. in Narew has made every effort to eliminate the risk of accidents. There is, however, a certain residual risk, which could lead to an accident, and this is connected mainly with the actions described below:

- using the machine for purposes other than those for which it is intended,
- being between the carrying vehicle and the machine while the engine is running and when the machine is being attached,
- being on the machine while the engine is running,
- operating the machine with removed or faulty safety guards,
- not maintaining safe distance from the danger zone or being within the zones while the machine is operating,
- operation of the machine by persons under the influence of alcohol,
- cleaning, maintenance and technical checks when carrying vehicle is connected and engine is running

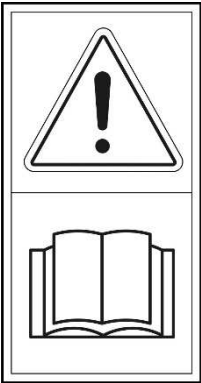



The minimal risk may be kept to a minimum by following the recommendations below:


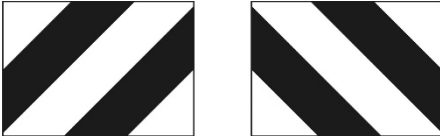

- operate the machine in prudent and unhurried manner,
- reasonably apply all the remarks and recommendations stated in the Operator's Manual,
- carry out repair and maintenance work in line with operating safety rules,
- carry out repair and maintenance work by persons trained to do so,
- use close fitting protective clothing,
- ensure unauthorised persons have no access to the machine, especially children,
- maintain a safe distance from forbidden or dangerous places
- do not climb on the machine when it is operating

## 2.3 INFORMATION AND WARNING DECALS

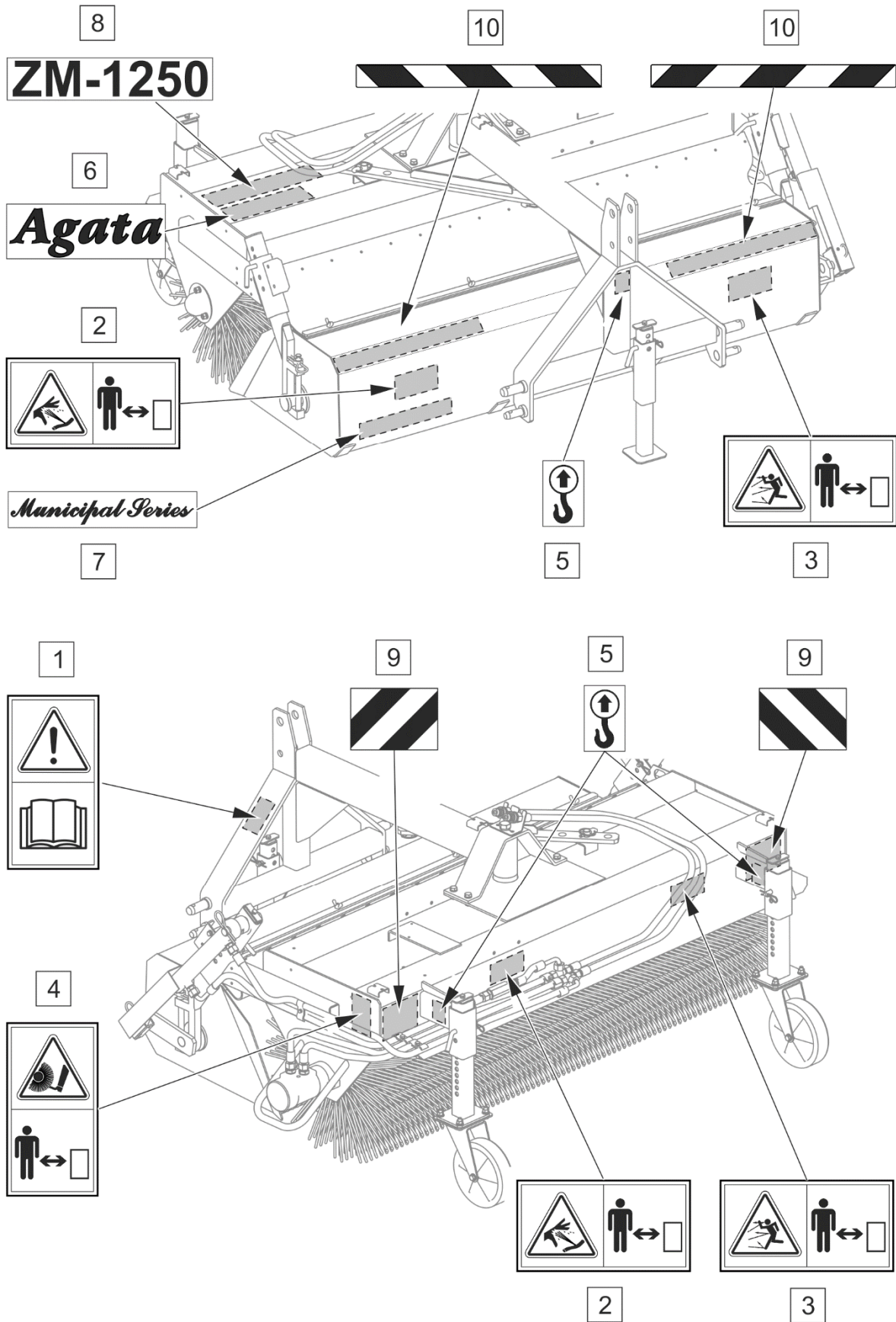
All signs should always be legible and clean, visible to the operator and also to persons possibly being in the vicinity of the machine in operation. If any safety sign is lost or illegible, it should be replaced with a new one. All elements having safety signs replaced during repairs should be affixed with these signs. Safety signs and decals may be purchased from the Manufacturer or the Seller.

**TABLE 2.1 Information and warning decals**

ITEM	SYMBOL	DESCRIPTION
1		<p>Before starting work, carefully read the Operator's Manual.</p>
2		<p>Pressurised liquid. Keep a safe distance.</p>
3		<p>Risk of injury caused by thrown objects. Keep a safe distance from the operating machine.</p>
4		<p>Do NOT approach and do NOT touch rotating brushes</p>

ITEM	SYMBOL	DESCRIPTION
5		Marking of points of suspension
6	<p style="text-align: center;"><b><i>Agata</i></b></p>	Trade mark
7	<p style="text-align: center;"><i>Municipal Series</i></p>	Additional marking
8	<p style="text-align: center;"><b>ZM-1250</b></p>	Sweeper model
9		Rear clearance marking
10		Front clearance marking

Numbers in the item column correspond to marking (FIGURE 2.1)



**FIGURE 2.1** Locations of information and warning decals.

Meaning of symbols (TABLE 2.1)

*SECTION*

**3**

---

**DESIGN AND  
OPERATION**

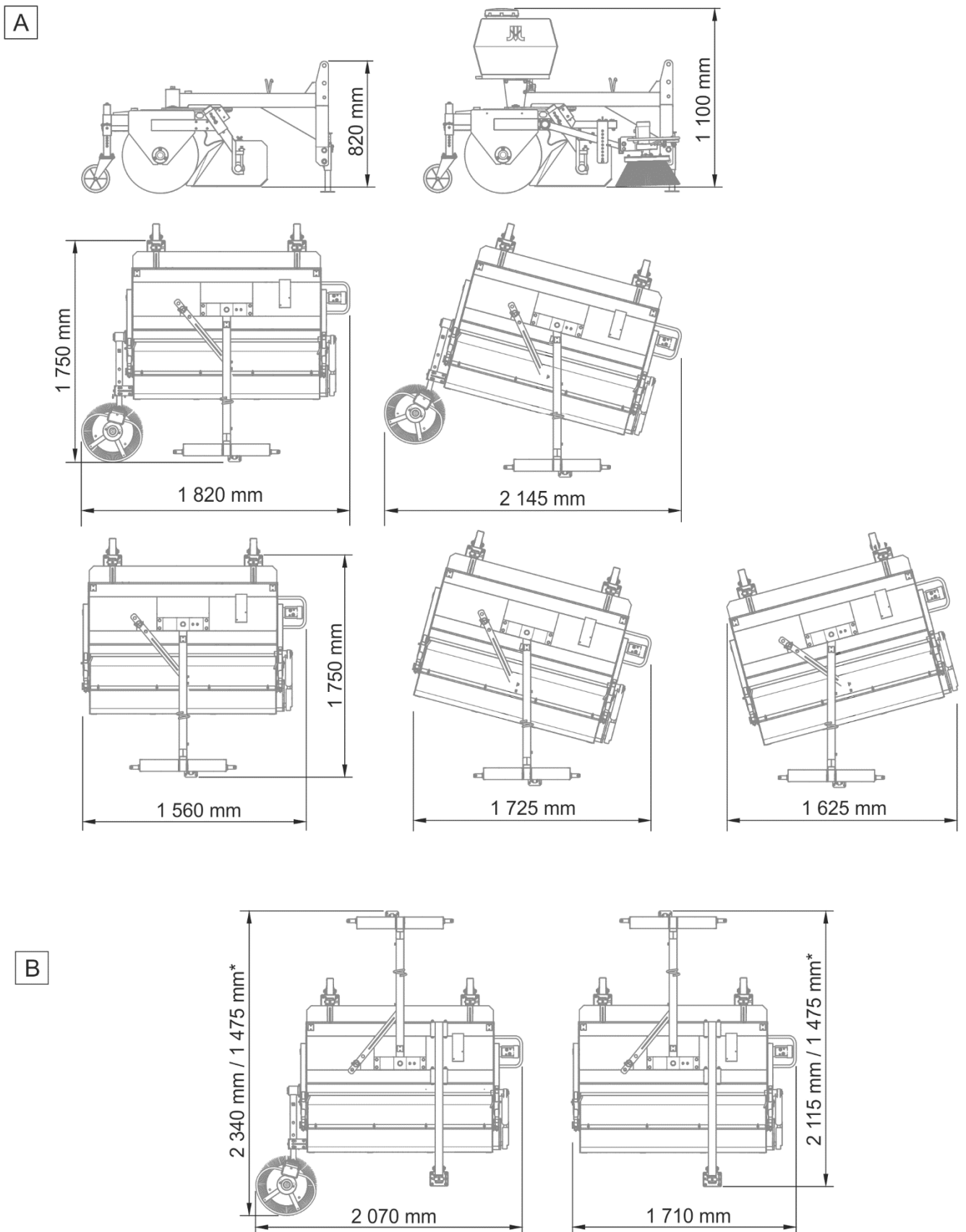
## 3.1 TECHNICAL SPECIFICATION

**TABLE 3.1 BASIC TECHNICAL DATA**

	Unit	
Model		<b>ZM-1250</b>
Mounting method: Three-point linkage according to ISO 730-1 - front loader - other	– – –	cat. I / II "narrow" ŁC-1650, EURO; acc. to the Manufacturer's offer
Sweeping width ( <i>perpendicularly, 0°</i> ): - without side brush - with side brush	mm mm	1,250 1,650
Sweeping width ( <i>tilting: 15°</i> ): - without side brush - with side brush ( <i>to the left/to the right</i> )	mm mm	1,200 1,400 / 1,820
Capacity* - with side brush - without side brush	m <sup>2</sup> /h m <sup>2</sup> /h	8,700 7,500
Recommended sweeping speed	km/h	6
Type of working components ( <i>depending on the machine version</i> )	–	roller brush roller brush + side brush
Power transmission	–	external hydraulic system of the carrying vehicle
Waste tank capacity	dm <sup>3</sup>	155
Tare weight ( <i>without water</i> ): - without side brush, with sprinkler system - with side brush, with sprinkler system - without side brush, sprinkler system and waste tank	kg kg kg	295 335 195
Rotation speed of brushes -roller brush -side brush	RPM RPM	100 - 200 150 - 300
Capacity of the sprinkler system's water tank	dm <sup>3</sup>	200
Quantity of sprinkling nozzles ( <i>with side brush / without side brush</i> )	pc.	5 / 3
Sprinkler system supply	–	electrical system 12V from the 7-pole socket in the carrying vehicle
Sprinkler system control	–	switch on the power cord

\* – for the recommended sweeping speed

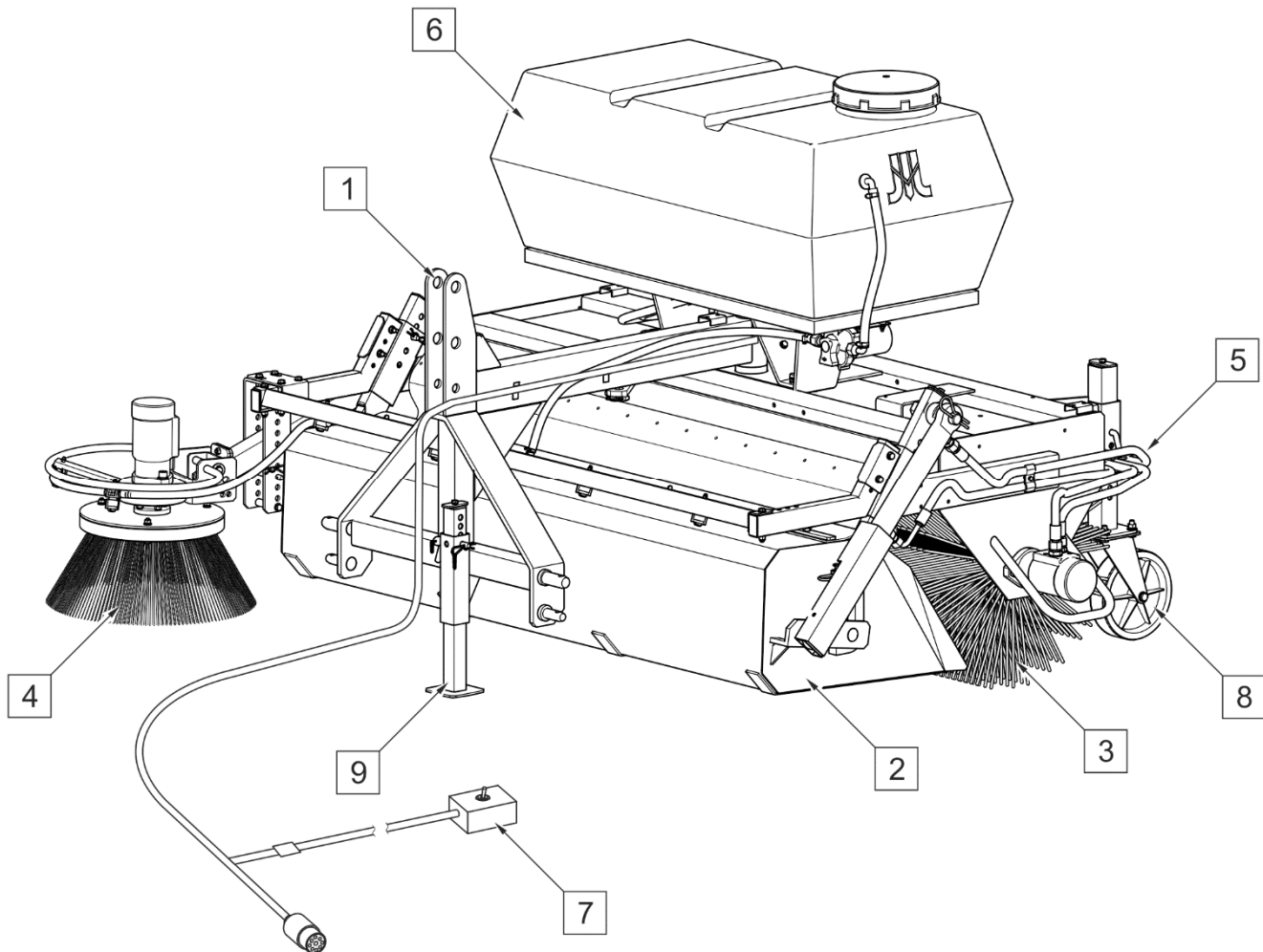
Level of noise emitted by the sweeper does not exceed 70 dB(A)



**FIGURE 3.1 External dimensions depending on the machine version**

\* - dimensions for the linkage other than the three-point linkage; (A) - mounted in the rear of the carrying vehicle; (B) - mounted in the front of the carrying vehicle

## 3.2 GENERAL DESIGN



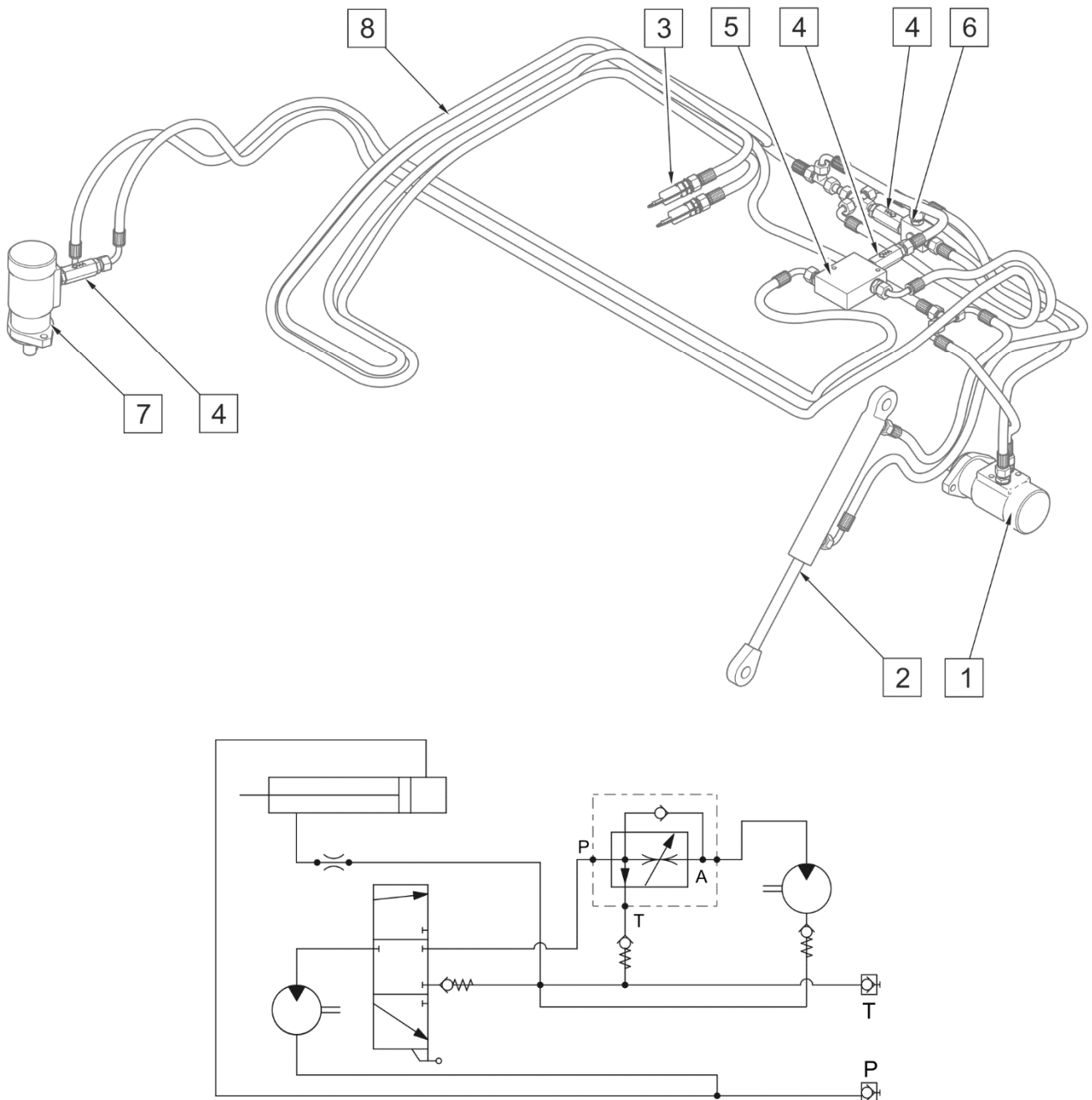
**FIGURE 3.2** General design

(1) - linkage, (2) - waste tank, (3) - roller brush, (4) - side brush, (5) - hydraulic system, (6) - sprinkler system, (7) - electrical system; (8) - jockey wheel; (9) - parking stand.

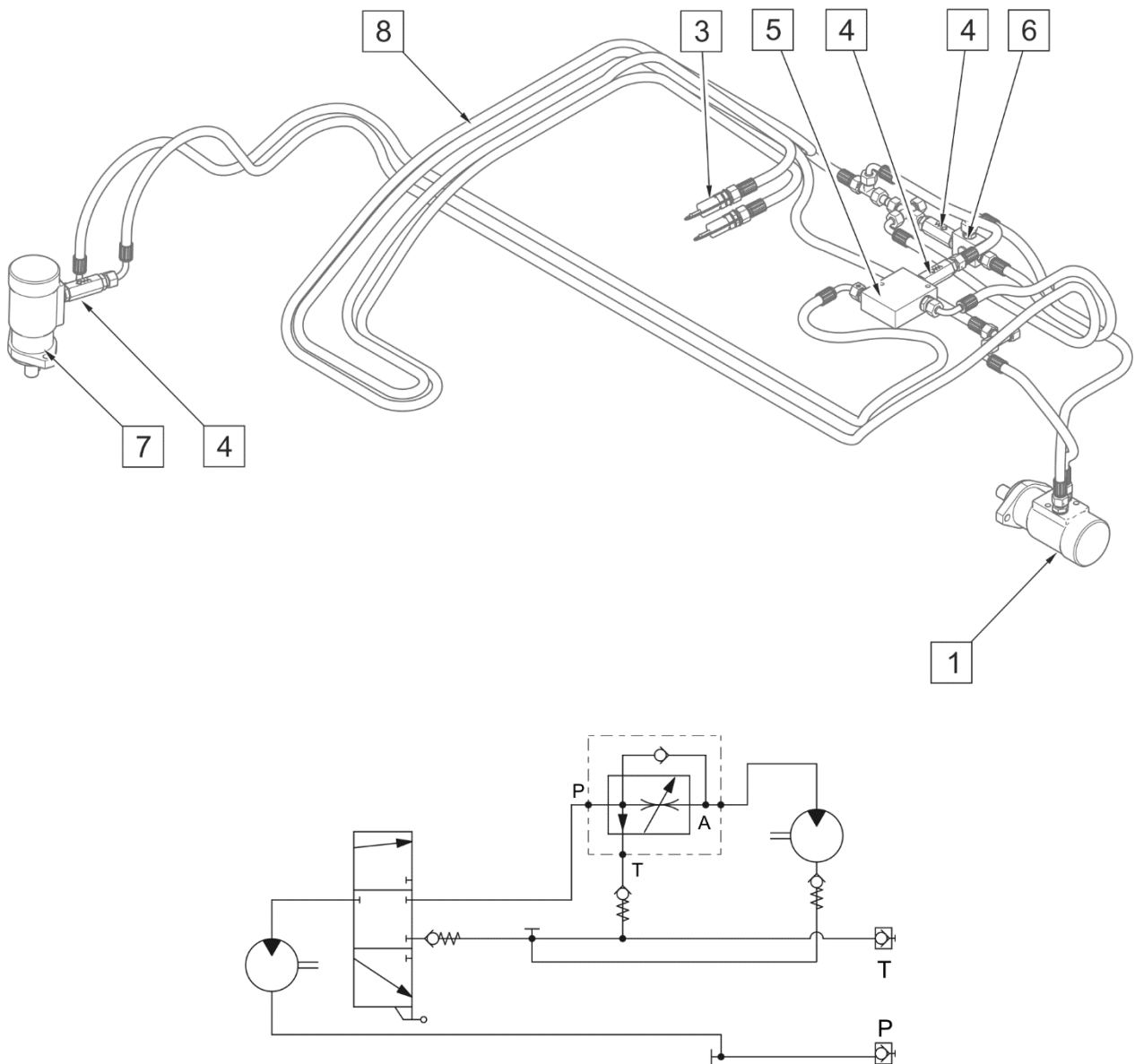
The sweeper's linkage (1) mounted on the frame by means of a pin allows rotation and operation in front of the carrying vehicle and also operation at an angle. Roller brush (3) driven by hydraulic motor directs dirt to waste tank (2), which can be emptied from the operator's seat using the hydraulic system (5). The sweeper can be additionally equipped with side brush (4) to allow sweeping close to walls or curbs. The sprinkler system (6) is controlled by means of the electrical system (7). Self-adjusting jockey wheels (8) support the machine on the ground during operation, while the sweeper unhitched from the carrying vehicle rests on its parking stand (9) or on the third jockey wheel.



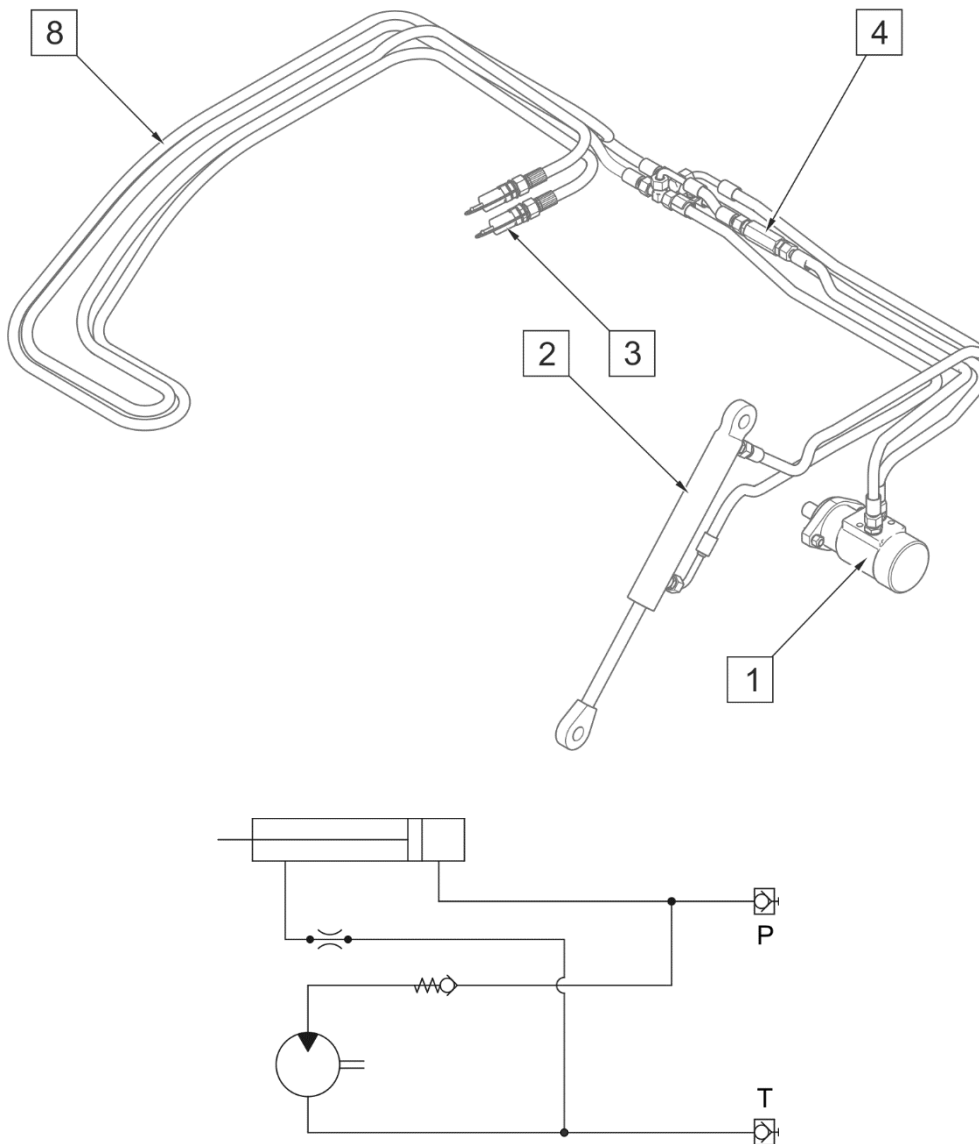
### 3.3 HYDRAULIC SYSTEM



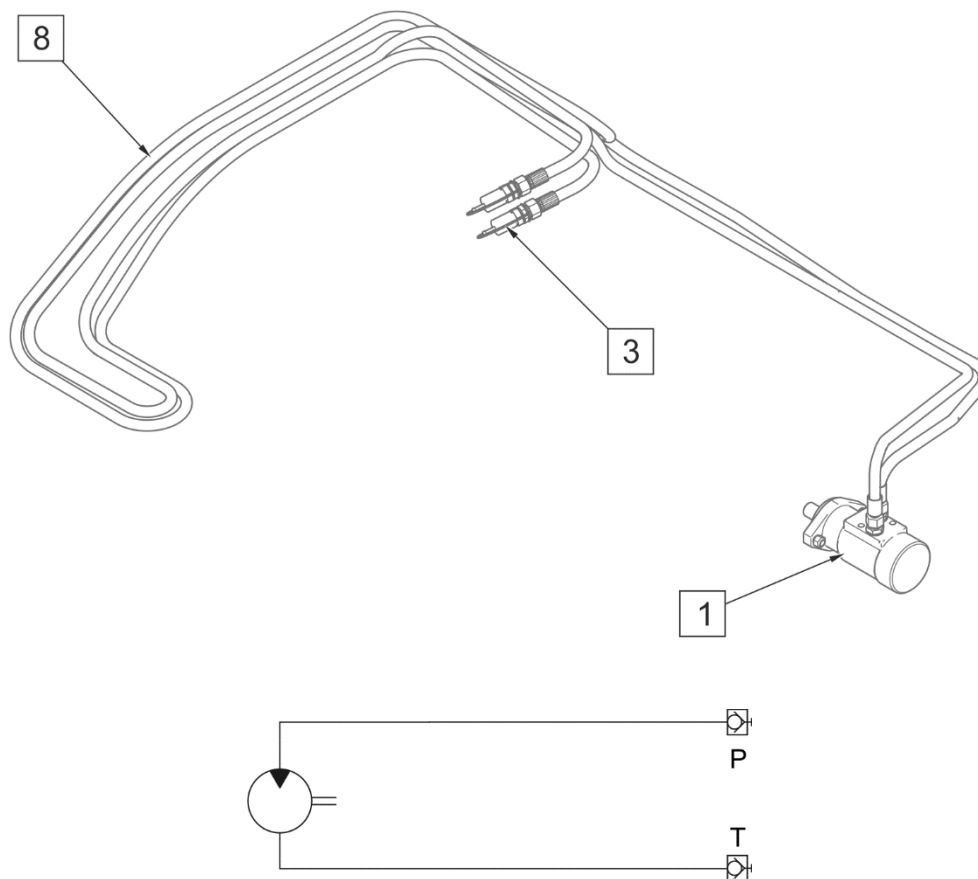
**FIGURE 3.3** Design of the hydraulic system (the sweeper with side brush and waste  
 (1) - hydraulic motor of roller brush drive, (2) - waste tank hydraulic tipping cylinder,  
 (3) - hydraulic quick couplers, (4) - check valve; (5) - flow regulator, (6) - side brush drive  
 distributor, (7) - hydraulic motor of side brush drive, (8) - hydraulic conduits



**FIGURE 3.4** Design of the hydraulic system (the sweeper with side brush, without (1) - hydraulic motor of roller brush drive, (3) - hydraulic quick couplers; (4) - check valve; (5) - flow regulator; (6) - side brush drive distributor; (8) - hydraulic conduits

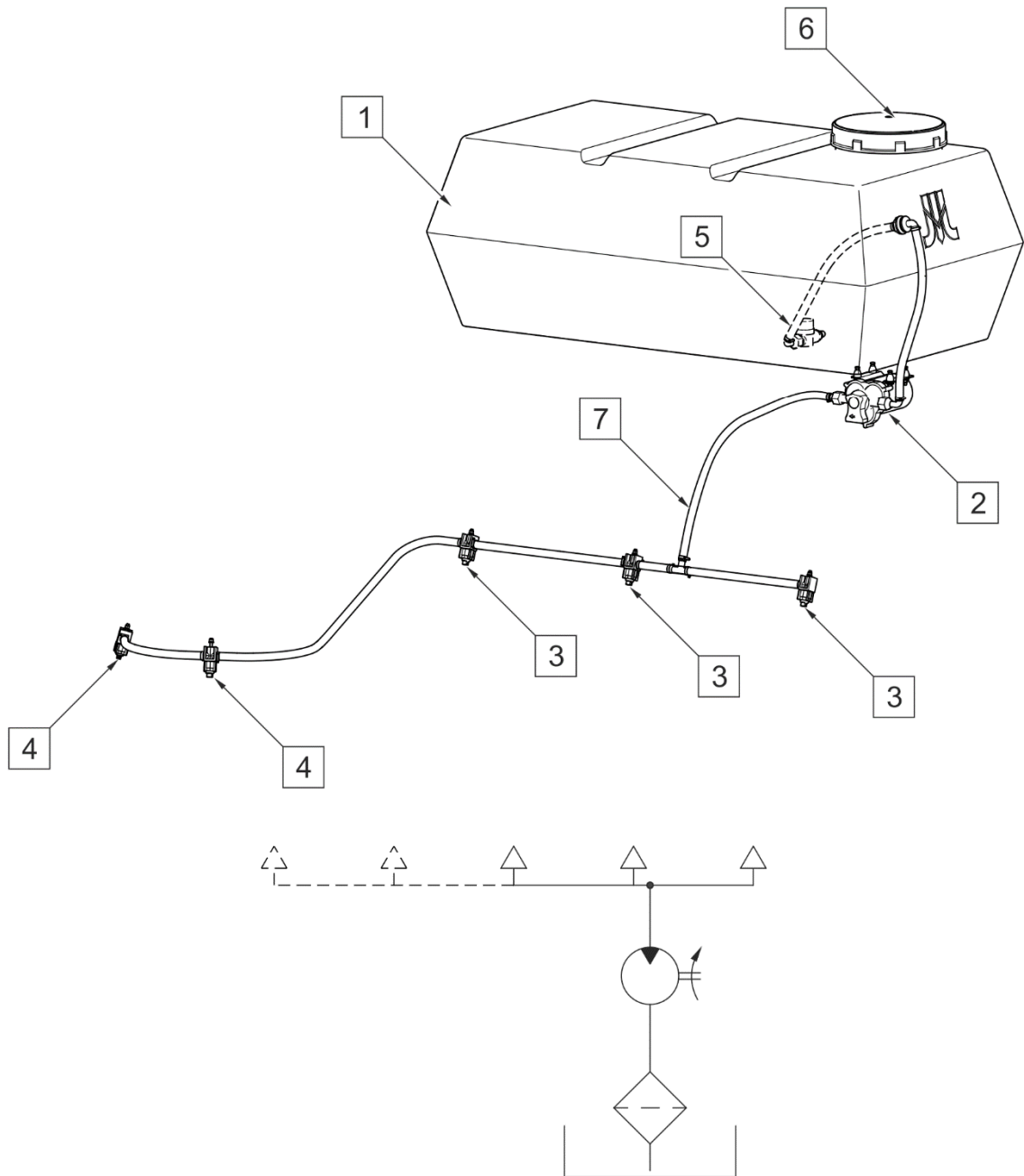


**FIGURE 3.5** Design of the hydraulic system (the sweeper without side brush, with (1) - hydraulic motor of roller brush drive, (2) - waste tank hydraulic tipping cylinder, (3) - hydraulic quick couplers, (4) - check valve; (6) - side brush drive distributor; (8) - hydraulic conduits



**FIGURE 3.6** Design of the hydraulic system (the sweeper without side brush, without  
(1) - hydraulic motor of roller brush drive, (3) - hydraulic quick couplers;  
(8) - hydraulic conduits

### 3.4 SPRINKLER SYSTEM



**FIGURE 3.7 Sprinkler system design**

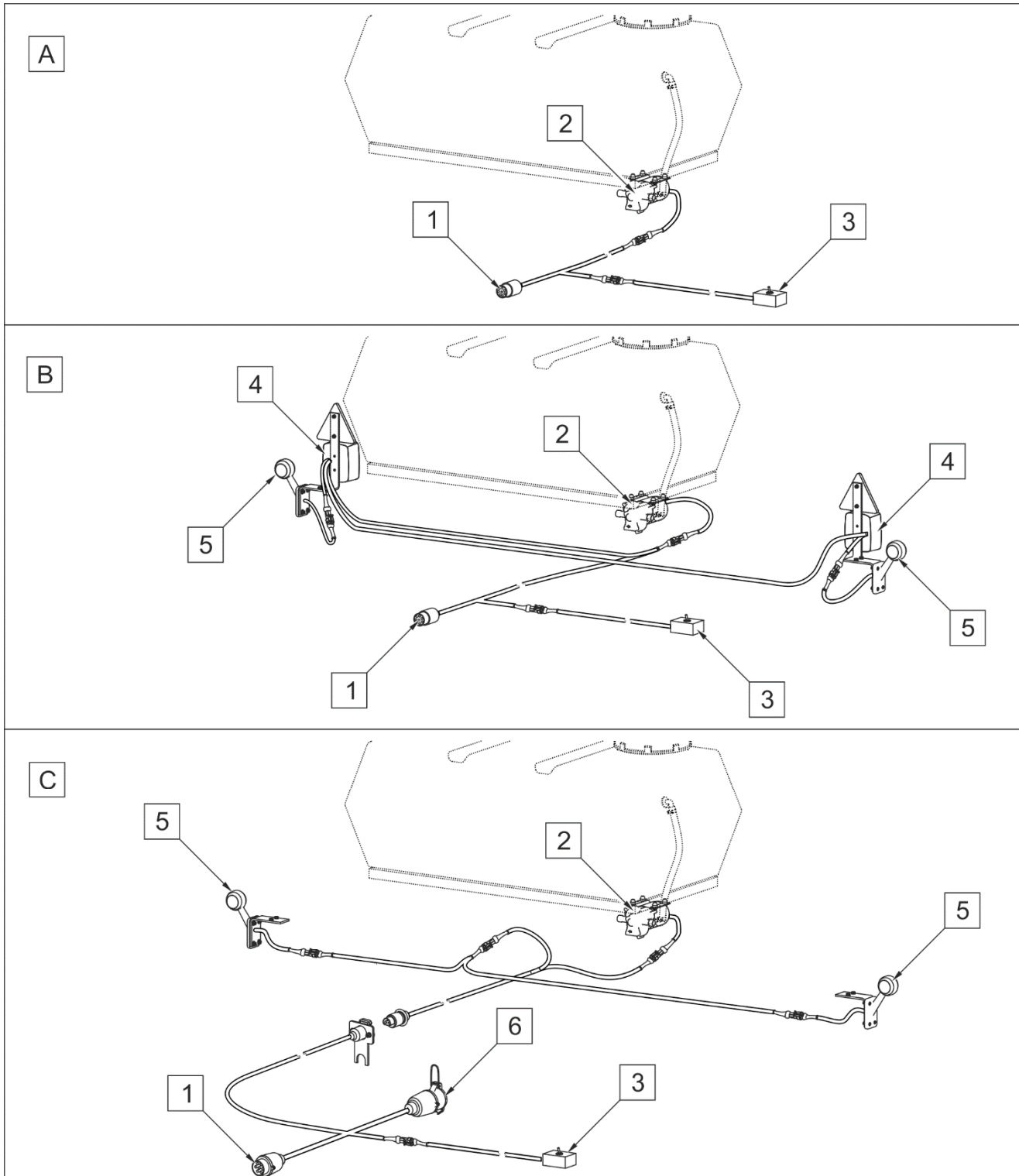
(1) - water tank; (2) - water pump; (3) - sprinkling nozzles of roller brush; (4) - sprinkling nozzles of side brush; (5) - water filter; (6) - filler plug; (7) - conduits



#### NOTE

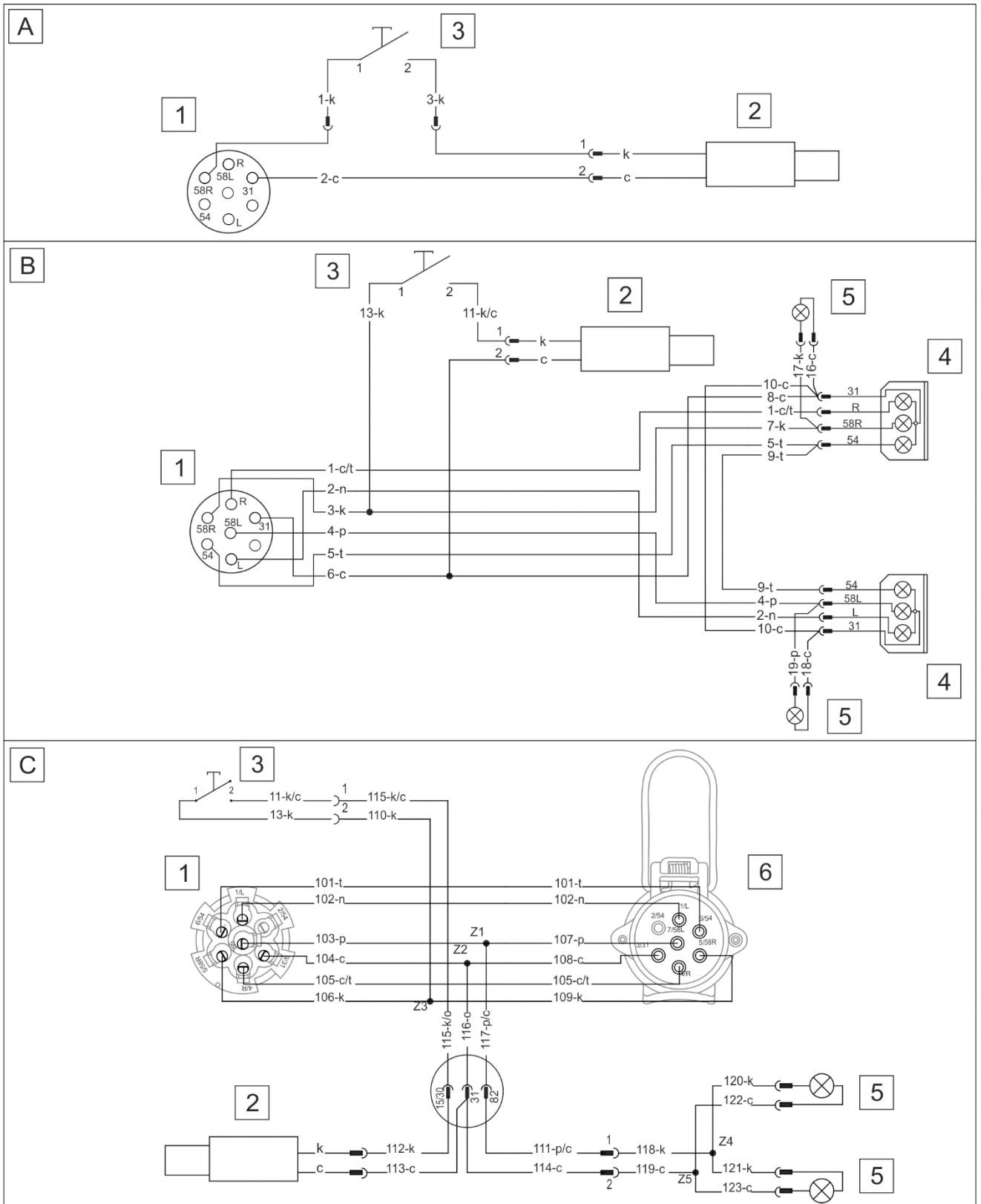
In special cases, the water filter (item 5) is an integral part of the water pump (item 2).

### 3.5 ELECTRICAL SYSTEM



**FIGURE 3.8 Design of the electrical system**

(A) - electrical system of sprinkler system; (B) - electrical system of sprinkler system and lighting system; (C) - electrical system for the front-mounted sweeper; (1) - 7-pole pin; (2) - water pump; (3) - sprinkler system switch; (4) - rear lamps; (5) - clearance lights; (6) - 7-pole socket



**FIGURE 3.9 Electrical system diagram**

*A - electrical system of sprinkler system; (B) - electrical system of sprinkler system and lighting system; (C) - electrical system for the front-mounted sweeper; (1) - 7-pole pin; (2) - water pump; (3) - sprinkler system switch; (4) - rear lamps; (5) - clearance lights; (6) - 7-pole socket*





*SECTION*

**4**

---

**CORRECT USE**

## 4.1 PREPARING FOR WORK

### **DANGER**



**Before using the machine, the user must carefully read this Operator's Manual.**

**The machine must never be used by persons who are not authorised to drive carrying vehicles, including children and people under the influence of alcohol or other drugs.**

**Non-compliance with the safety rules of this Operator's Manual can be dangerous to the health and life of the operator and others.**

**Before starting the machine, make sure that there are no bystanders in the danger zone.**

The manufacturer guarantees that the machine is fully operational and has been checked according to quality control procedures and is ready for use. This does not release the user from an obligation to check the machine's condition after delivery and before first use. The machine is delivered to the user completely assembled. Prior to connecting to the carrying vehicle, machine operator must verify the machine technical condition. In order to do this:

- the user must carefully read this Operator's Manual and observe all recommendations, understand the design and the principle of machine operation
- check the condition of protective paint coat,
- inspect machine's individual components for mechanical damage resulting from incorrect transport (dents, piercing, bent or broken components),
- check all the lubrication points, lubricate the machine as needed according to recommendations provided in section 5 *MAINTENANCE*,
- check technical condition of the hydraulic system;
- check technical condition of hitching system pins and locking cotter pins,
- check technical condition of protective shields and correctness of mounting of the shields and warning signs.

**DANGER**

Before starting the tractor with attached sweeper make sure the external hydraulic system control levers are in off position, otherwise it may lead to uncontrolled operation of the machine.

**ATTENTION**

Non-adherence to the recommendations contained in the Operator's Manual or incorrect use may cause damage to the machine.

The technical condition before starting the machine must be no cause for concern.

If all the above checks have been performed and there is no doubt as to the machine's good technical condition, it can be connected to carrying vehicle, started and all its individual systems checked. In order to do this:

- connect the machine to the carrying vehicle's linkage (see *HITCHING TO CARRYING VEHICLE*),
- connect hydraulic system conduits and electrical system leads (*if installed*),
- start the machine (see *SWEEPER OPERATION*)
- check operation of the hydraulic system and control the system for tightness,
- check operation of the sprinkler system and the lighting system (*if installed*)

**ATTENTION**

It is recommended to first run the sweeper in the raised position, because oil circulation in the wrong direction can cause waste tank to tip and damage the machine.

In the event of a disruption in the operation of the machine immediately discontinue its use, find and remove the fault. If a fault cannot be rectified or the repair could void the guarantee, please contact the Manufacturer for additional clarifications.

**ATTENTION**

Before using the machine always check its technical condition. In particular, check the technical condition of the hitch and hydraulic system.

## 4.2 CHECKING TECHNICAL CONDITION

When preparing the machine for use, check individual elements according to guidelines presented in table 4.1.

**TABLE 4.1 TECHNICAL INSPECTION SCHEDULE**

DESCRIPTION	MAINTENANCE ACTIVITIES	FREQUENCY
Condition of safety guards	Check the technical condition of safety guards, if complete and correctly mounted.	Before starting work
Correct installation of roller brush and side brush (depending on the machine version)	Check if correctly installed	
The technical condition of the roller brush and side brush (if installed)	Visually inspect and, if necessary, replace (see 5.4 REPLACEMENT OF ROLLER BRUSH, 5.5 REPLACEMENT OF SIDE BRUSH)	
Technical condition of warning signs	Inspect visually the legibility and completeness of warning signs	
Check if all main nut and bolt connections are properly tightened	Tightening torque values should be according to table (5.6)	Every 6 months
Lubrication	Lubricate elements according to section „5.9 LUBRICATION”.	According to table (5.5)



### ATTENTION

The machine must not be used when not in working order.

## 4.3 HITCHING TO CARRYING VEHICLE



### ATTENTION

Before hitching the machine to carrying vehicle, the user must carefully read the operator's manual of the carrying vehicle.



### DANGER

When hitching, there must be nobody between the machine and the carrying vehicle. Exercise caution when hitching the machine to carrying vehicle.

The sweeper can be hitched to a carrying vehicle that meets the requirements contained in Table 1.1 *REQUIREMENTS FOR CARRYING VEHICLE*.

Before hitching the sweeper to the carrying vehicle, check the compatibility of the machine's linkage with the carrying vehicle's linkage. Because the sweeper can be equipped with different types of linkage, comply with the principles of hitching specified by the carrying vehicle manufacturer.



### ATTENTION

During the sweeper operation, the linkage must have the possibility of ground surface tracking. Otherwise, the machine may get damaged. Carrying vehicle weight must not be transferred to the sweeper.



### DANGER

To hitch the machine to carrying vehicle use only genuine pins and safeguards.

When hitching the sweeper to the tractor's three-point linkage, adhere to the following guidelines:

- Reverse the tractor so as to move the lower links of the tractor's three-point linkage to the pins of the sweeper linkage.
- Set the lower links of the tractor at appropriate height.
- Switch off tractor's engine and prevent tractor from unintentional moving.
- Connect the sweeper linkage lower links with the tractor lower pins and secure.

- Using a pin, connect top link (central connector) of the tractor linkage with the top point of the sweeper linkage and secure. Set stabilizers (tensioners) of tractor linkage lower links tractor so as to eliminate lateral movement of the machine.
- Connect hydraulic conduit plugs to the appropriate sockets on the tractor.
- Connect the plug of the electrical system of the sprinkler system and lighting system (if installed) to a 7-pole socket on the tractor.
- Lift sweeper using tractor's three point linkage.
- Raise the parking stand and lock it with a pin and securing cotter pin.

Both lower links of the tractor's three point linkage are recommended to be set at the same height .

**DANGER**

When hitching, there must be nobody between the sweeper and the carrying vehicle.

**ATTENTION**

Comply with the recommendations relating to linkage and mounting points.

Connect hydraulic conduit connectors to sockets of one section of the carrying vehicle's external hydraulic system with the locking function in switched on position and the possibility of changing the direction of oil circulation.

**DANGER**

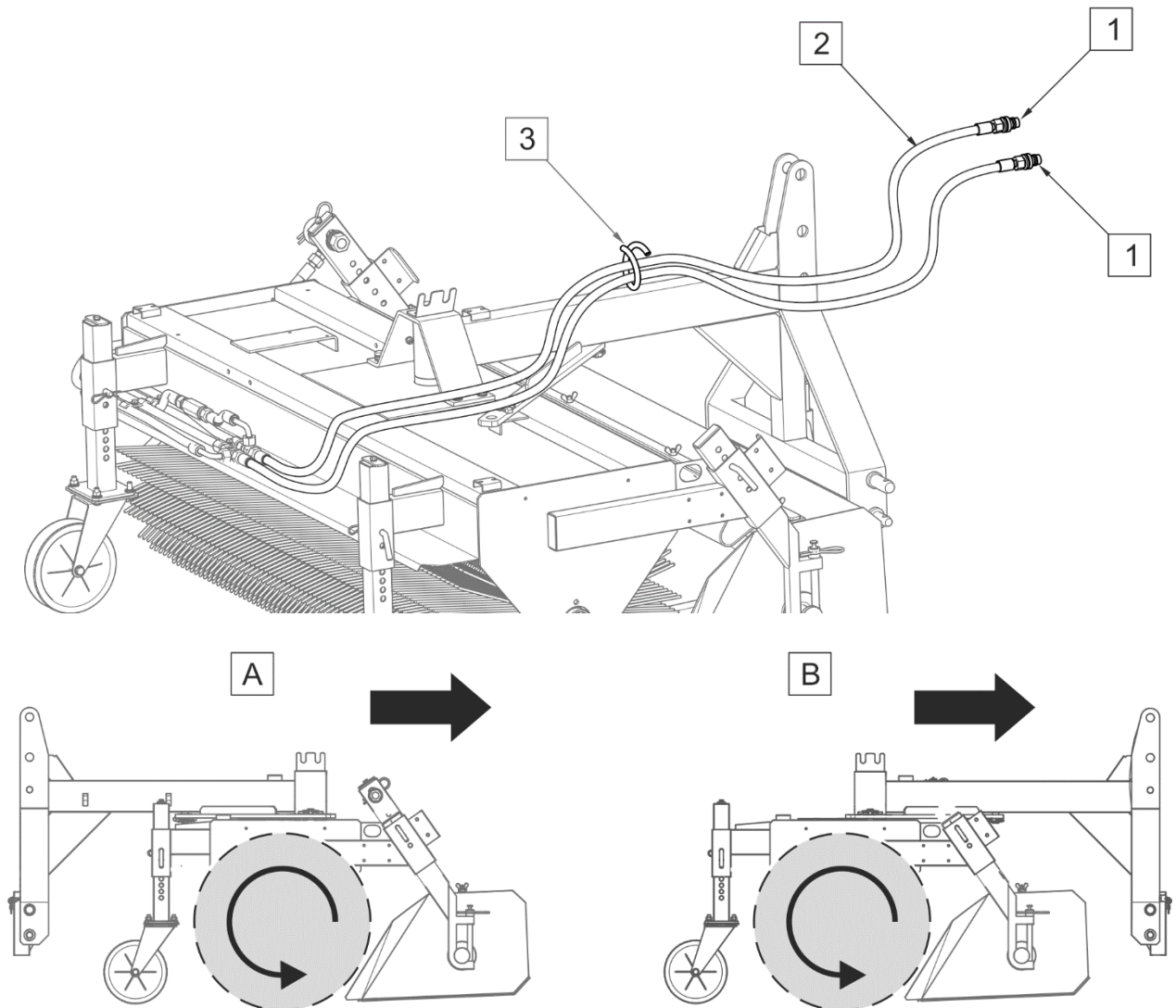
Prior to connecting individual system conduits, the user must carefully read the carrying vehicle operator's manual and observe all Manufacturer's recommendations.

**DANGER**

When connecting the hydraulic conduits, make sure that the hydraulic system of the carrying vehicle is not under pressure.

Activate appropriate hydraulic circuit using the hydraulic manifold lever in the carrying vehicle. Check roller brush rotation direction. The brush should rotate in the direction opposite to travel direction. If the brush does not rotate, swap the hydraulic conduit plugs. If

the sweeper is equipped with the three-point linkage, hydraulic conduits should be routed through bracket (3) (FIGURE 4.1)



**FIGURE 4.1 Hydraulic system connection**

(A) - front-mounted sweeper; (B) - rear-mounted sweeper; (1) - hydraulic conduit connectors;  
(2) - hydraulic conduits; (3) - conduit bracket



### ATTENTION

During operation, the connecting cables should be routed so that they do not get entangled in moving machine parts.



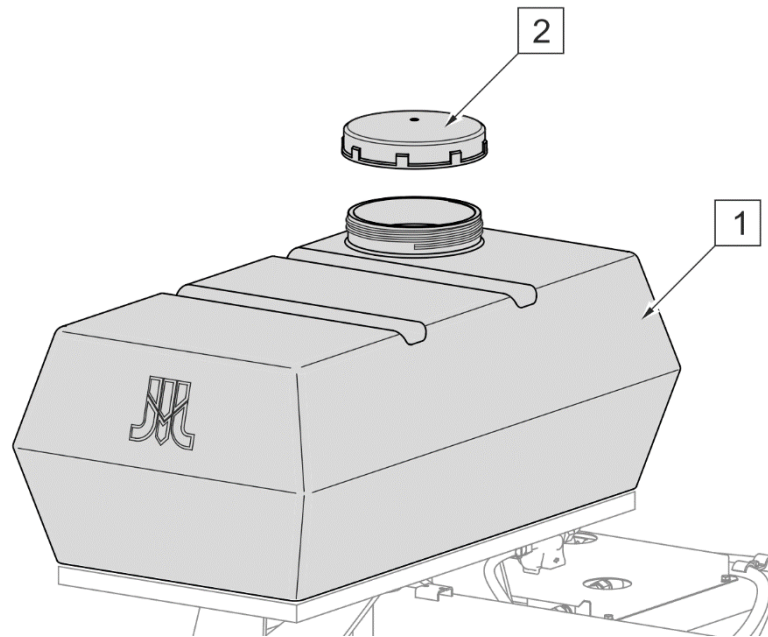
Before beginning work using the sweeper, check the oil level in tractor hydraulic system.

## 4.4 SWEEPER OPERATION

### 4.4.1 FILLING THE SPRINKLER SYSTEM TANK

The sweeper with sprinkler system is equipped with water tank holding 200 litres of water.

Fill the water tank (1) through the filler opening secured with a cap (2) equipped with a vent (FIGURE 4.2).



**FIGURE 4.2** Water tank of sprinkler system

(1) - water tank, (2) - filler plug;



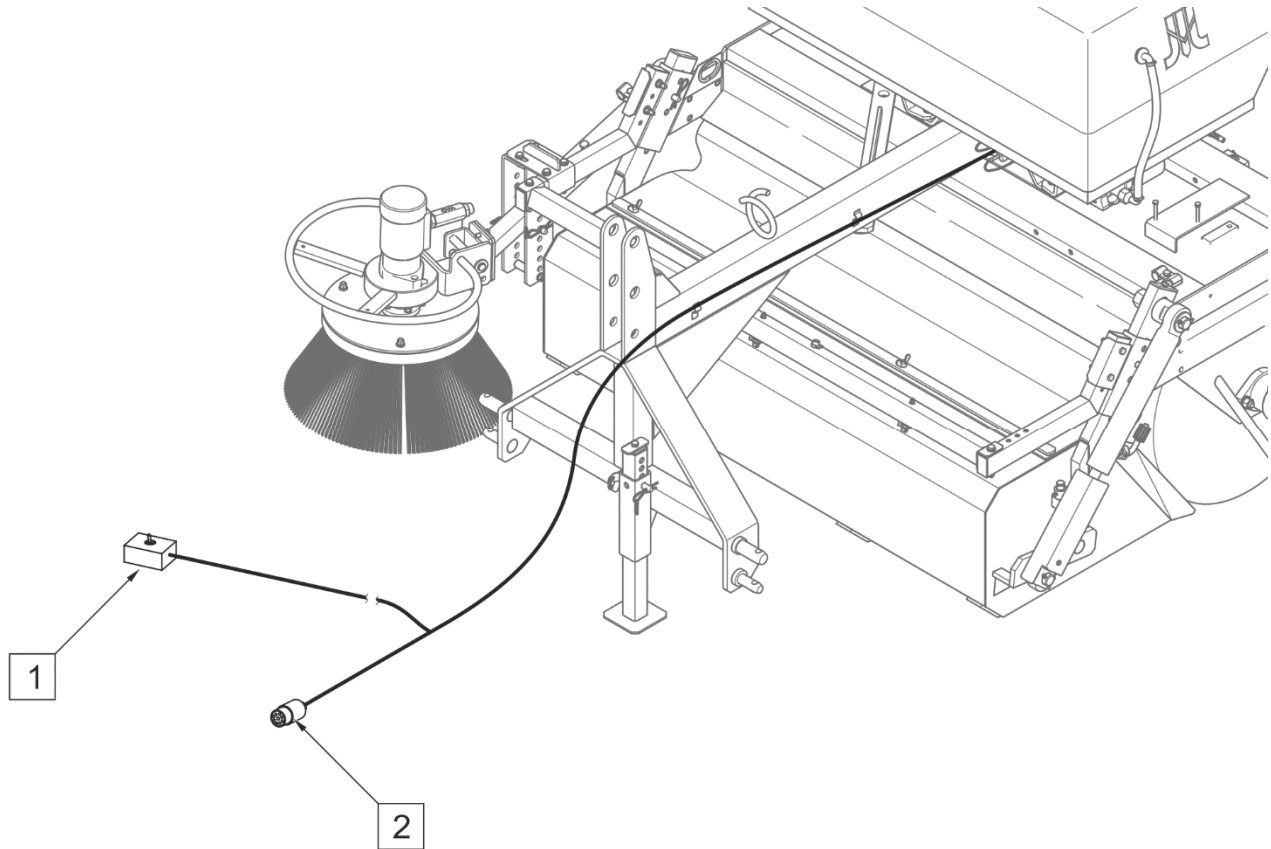
### ATTENTION

If there is a risk that temperatures drop below 0°C, drain water from the sprinkler system. Blow the water pump through with compressed air.



#### 4.4.2 SPRINKLER SYSTEM CONTROL

Connect electrical system plug (2) to 12V 7-pole socket in the carrying vehicle. Switch the sprinkling system on or off using the switch (1) on the power cord (FIGURE 4.3). Place the switch in the operator cab in an easily accessible place.



**FIGURE 4.3 Sprinkler system control**

(1) - sprinkler system switch, (2) - 7-pole socket plug;

#### 4.4.3 EMPTYING THE WASTE TANK

Before emptying the waste tank, raise the sweeper to a height of at least 0.5m. Waste tank emptying (FIGURE 4.4) is carried out from the driver's position using the hydraulic manifold lever, by reversing the oil flow direction. After emptying the tank restore the previous setting of the hydraulic circuit.



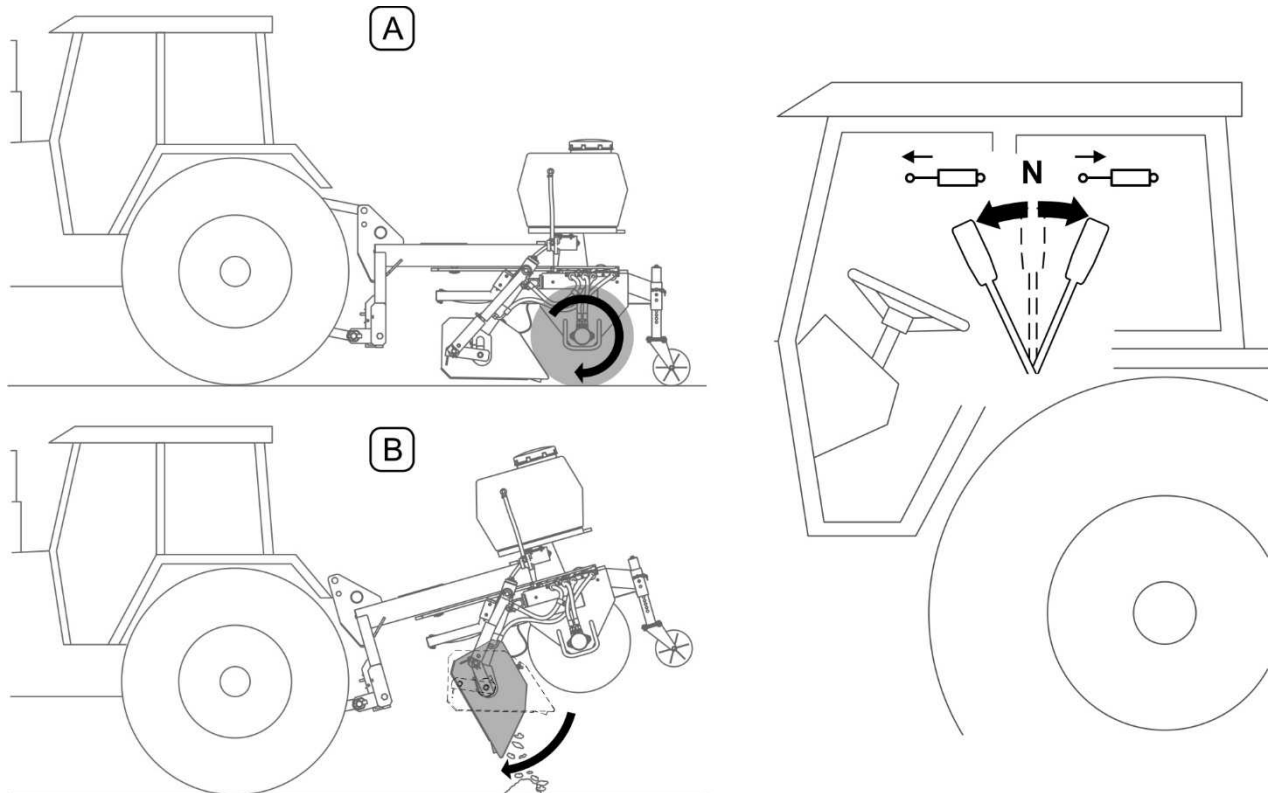
#### **DANGER**

Do NOT go under the raised sweeper.



#### **ATTENTION**

Waste tank can be opened and closed hydraulically only after lifting the sweeper.



**FIGURE 4.4 Emptying the waste tank**

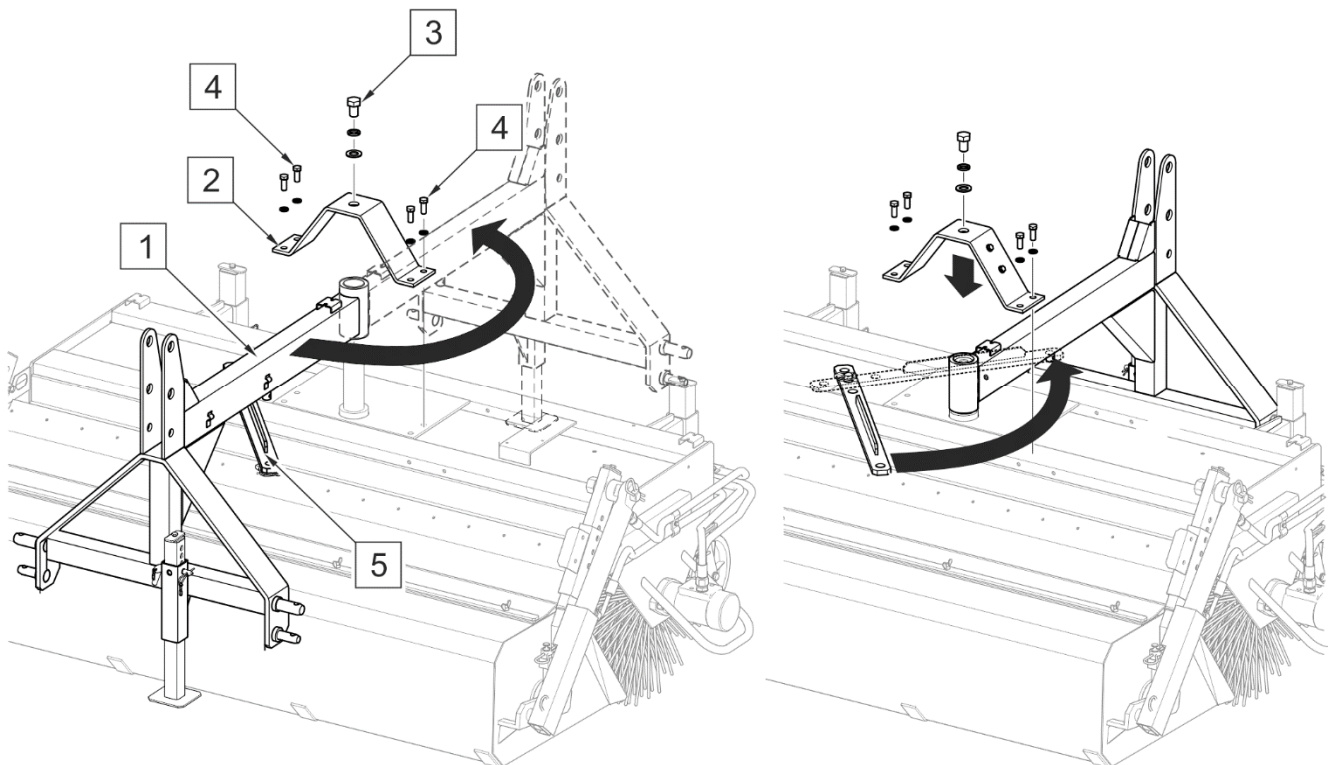
(A) - sweeping, (B) - emptying the tank

#### 4.4.4 ADAPTING THE SWEEPER FOR OPERATION IN FRONT OF THE CARRYING VEHICLE.

The sweeper can be adapted for operation in front of the carrying vehicle. To adapt the sweeper for operation in front of the carrying vehicle (FIGURE 4.5), turn the sweeper's linkage as follows:

- remove cotter pin securing strip (5)
- unscrew bolt (3) of main pin
- unscrew bolts (4) fixing the bracket (2) of main pin
- raise the linkage frame (1), turn it by 180° and install on the main pin,
- screw down the bracket (2).
- turn the strip (5), install it on the pin of the linkage frame and secure with a cotter pin

For the sweepers equipped with the sprinkler system, remove the water tank with brackets before removing the bracket (2). Reinstall the water tank after turning the linkage frame and screwing the bracket down.



**FIGURE 4.5** Setting the sweeper for operation in front of the carrying vehicle.

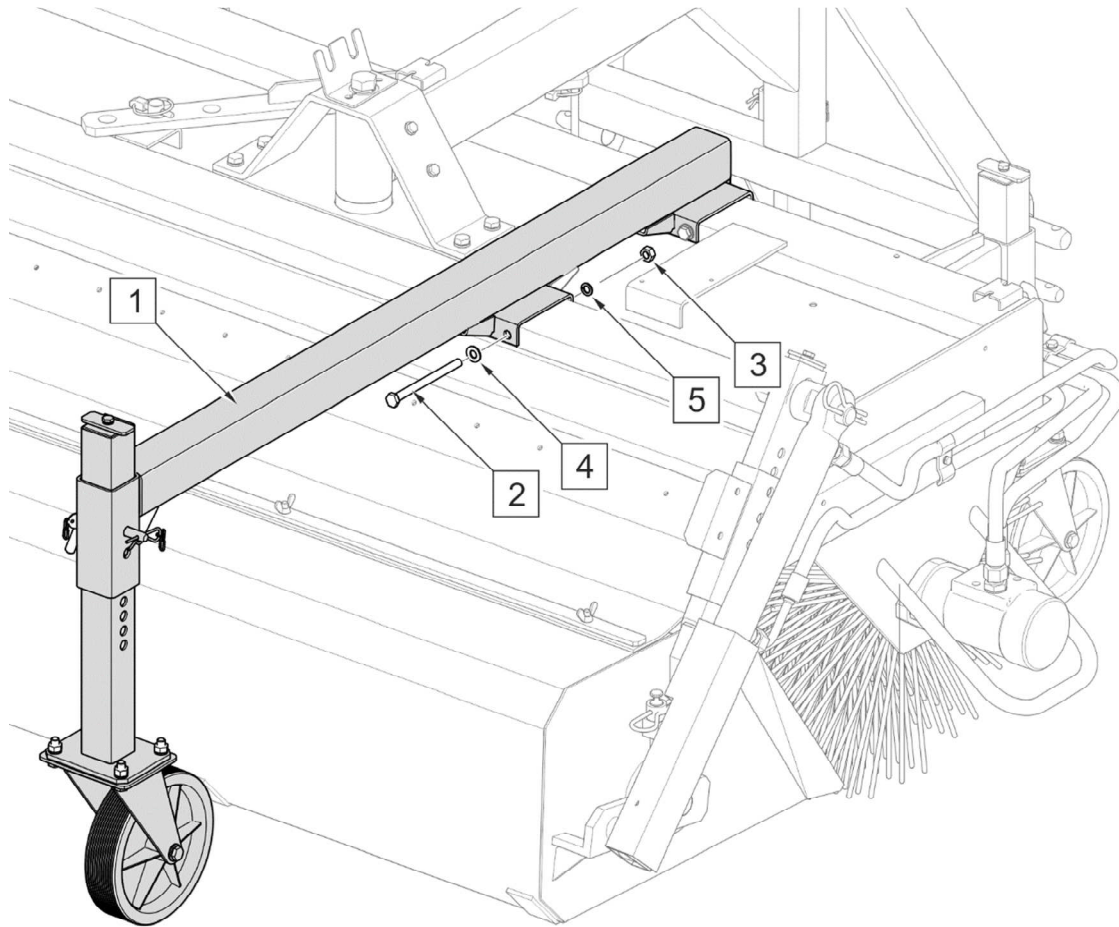
(1)- linkage frame; (2)- main pin bracket; (3)- main pin bolt; (4)- bracket fixing bolts; (5)- strip



### ATTENTION

The machine is designed to operate on even surfaces without obstacles such as humps, raised wells, steep climbs. Exercise extreme caution when crossing such obstacles. It is recommended to reduce the speed and even raise the machine.


To improve ground surface tracking during sweeper operation in front of the carrying vehicle, attach additional jockey wheel to sweeper frame (*catalogue number 12N-220000*). Screw the bracket (1) with the jockey wheel (FIGURE 4.6) down to the sweeper's frame using bolts (2), nuts (3) and washers (4) and (5). Set the additional jockey wheel at a proper height (see 5.1 ADJUSTMENT OF ROLLER BRUSH).



**FIGURE 4.6** Installing the front jockey wheel (option)

(1) - jockey wheel bracket; (2) - M10x130 bolt; (3) - M10 nut; (4) - 10-100HV washer; (5) - Z10.2 spring washer

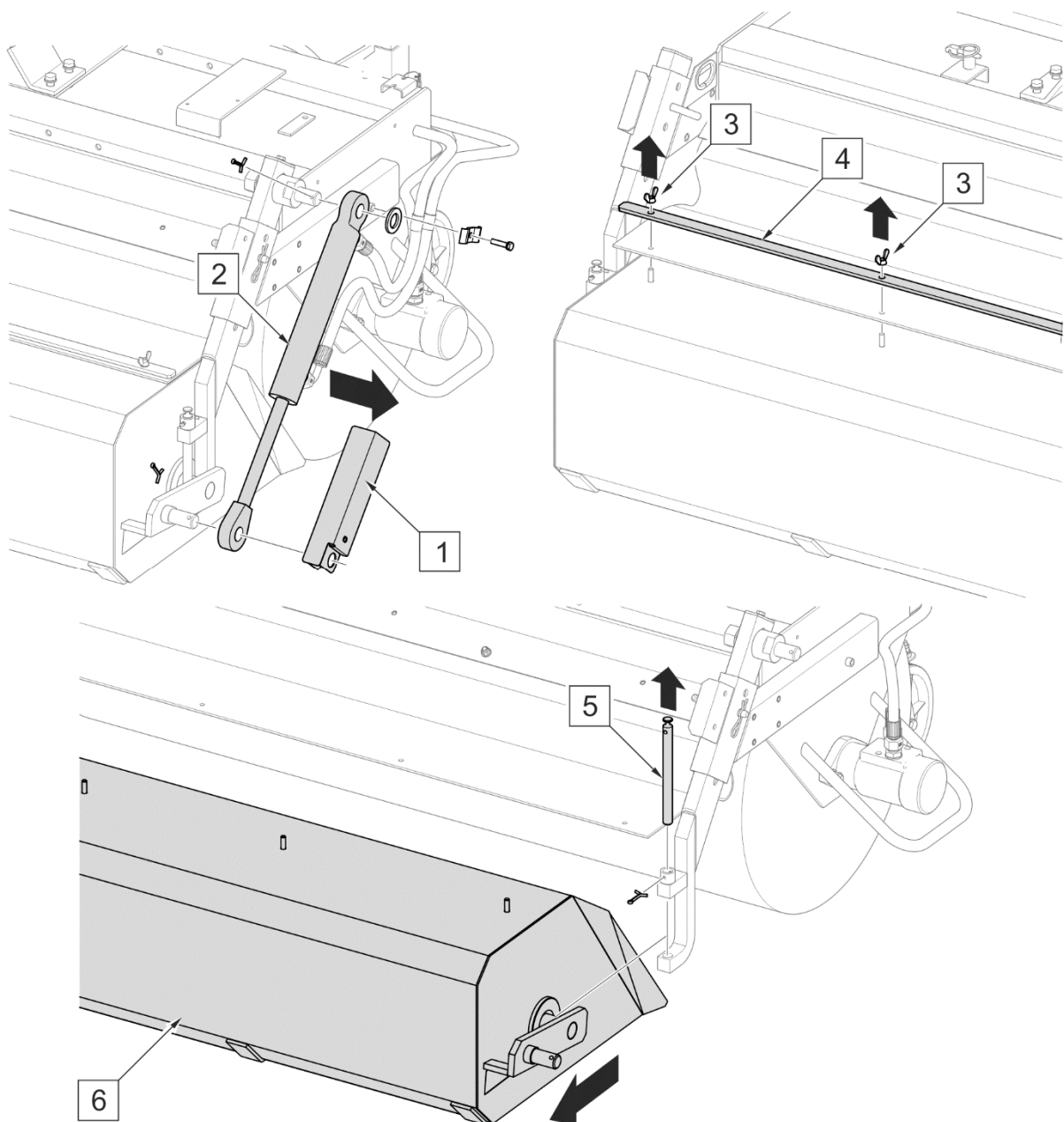
**4.4.5 ADAPTING THE SWEEPER FOR OPERATION WITHOUT THE WASTE TANK**

	<p><b>DANGER</b></p> <p>The hydraulic system must be partially dismantled in order to adapt the sweeper for operation without the waste tank. Work connected with the hydraulic system should be entrusted to the appropriately qualified persons.</p>
---	--

The sweeper equipped with the waste tank can be adapted for operation without the waste tank. To dismantle the waste tank:

- Remove the shield of the waste tank hydraulic tipping cylinder (1).
- Dismount cylinder (2) with conduits.
- Adapt the hydraulic system (see FIGURE 3.4 and 3.6)

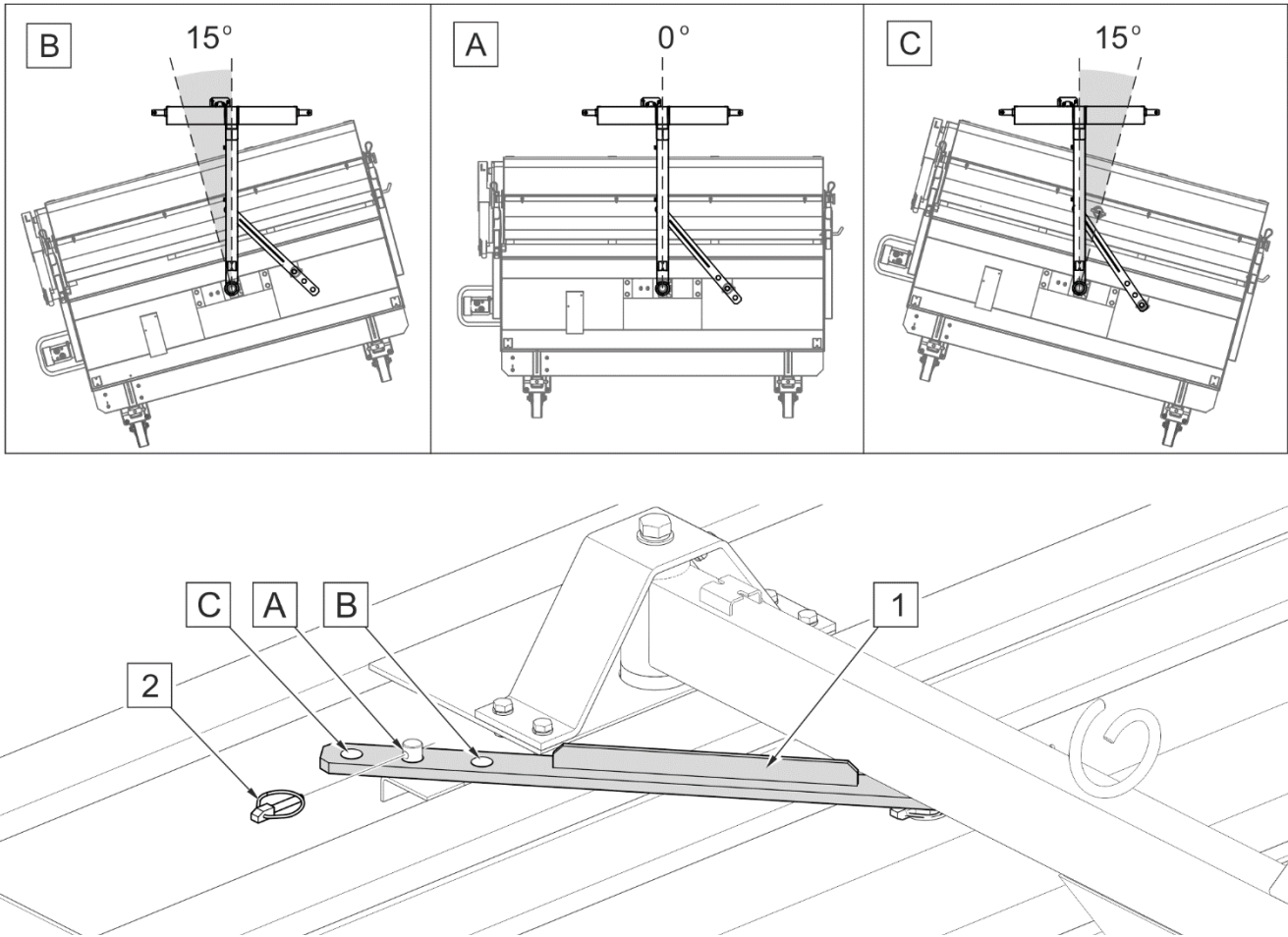
- Undo wing nuts (3) of the rubber apron so as to remove the clamping strip (4). During sweeping without the waste tank, apron hangs down and provides protection against ejected particles.
- Take out cotter pins and remove locks (5) of the tank linkage from the arms on the right side and the left side and then, slide the complete waste tank from the catches.
- When the above preparations are completed, the machine is ready for sweeping without waste tank.



**FIGURE 4.7 Removing the hydraulic cylinder and rubber apron strip**

(1) - hydraulic cylinder shield; (2) - hydraulic cylinder; (3) - wing nuts; (4) - clamping strip;  
(5) - lock; (6) - waste tank


**4.4.6 CHANGING THE SWEEPER'S WORKING ANGLE**



**FIGURE 4.8** Changing the sweeper's working angle  
 (1) - strip; (2) - securing cotter pin; (A) - 0° tilt; (B) and (C) - 15° tilt

To set the working angle of the roller brush (FIGURE 4.8), change the position of the pin in the appropriate retaining hole (A), (B), (C) of the strip (1). The pin is installed in hole (A) of the strip (1) when the sweeper's tilt during operation is 0°. Lock the pin in selected position using securing cotter pin (2). The pin is installed in holes (B) and (C) when the working sweeper is tilted by 15° to the right and to the left. The sweeper should be set at an angle during operation without the waste collecting tank.

In case of the sweeper equipped with side brush and three-point linkage, (B) setting is used only during operation of the sweeper in front of the carrying vehicle.



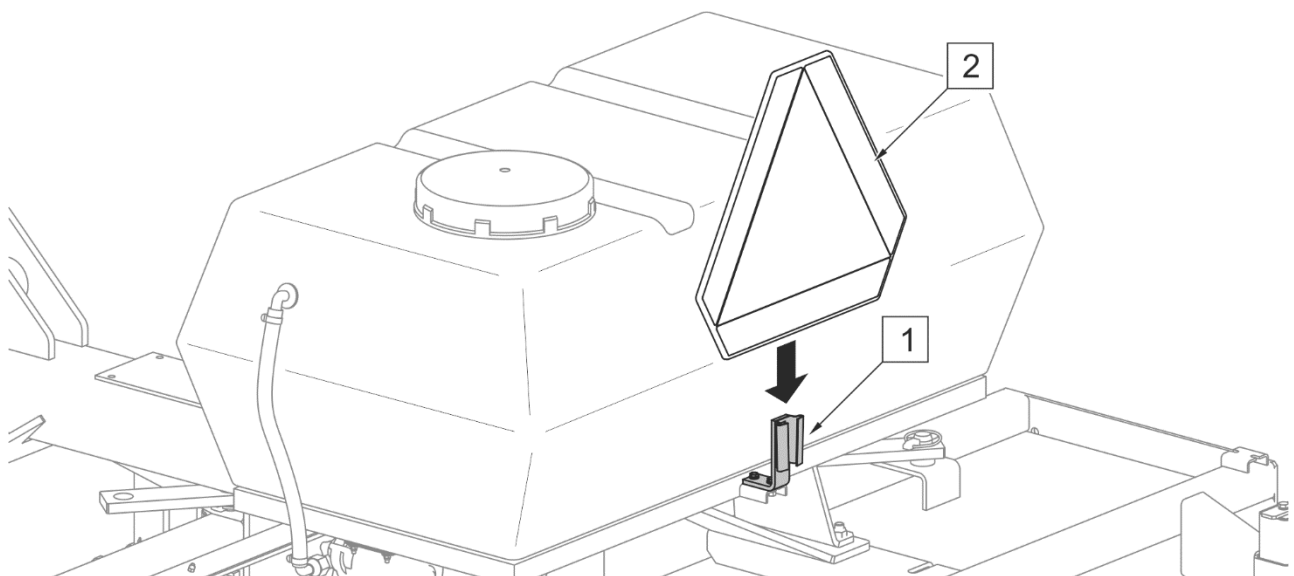
**ATTENTION**

During operation, the carrying vehicle's linkage must be set in such a manner as to enable ground surface tracking. Carrying vehicle weight must not be transferred to the sweeper.

## 4.5 DRIVING ON PUBLIC ROADS

When driving on public roads, respect the road traffic regulations, exercise caution and prudence. If the machine is operated on pavements special attention should be paid to the bystanders likely to be near the working machine. Listed below are the key guidelines.

- Before moving off make sure that there are no bystanders, especially children, near the machine or the tractor. Take care that the driver has sufficient visibility.
- Make sure that the machine is correctly attached to the tractor, and linkage is properly secured.
- The maximum working speed and the maximum speed allowed by road traffic regulations must not be exceeded. Travelling speed should be adjusted to existing road conditions, pavement condition and other conditions.
- While operating the machine, turn on the orange beacon light in the carrying vehicle.
- If the sweeper obscures the slow-moving vehicle warning sign attached to the back of the tractor, the warning sign must be mounted on a dedicated bracket (FIGURE 4.9) on the sweeper frame (available as an option).

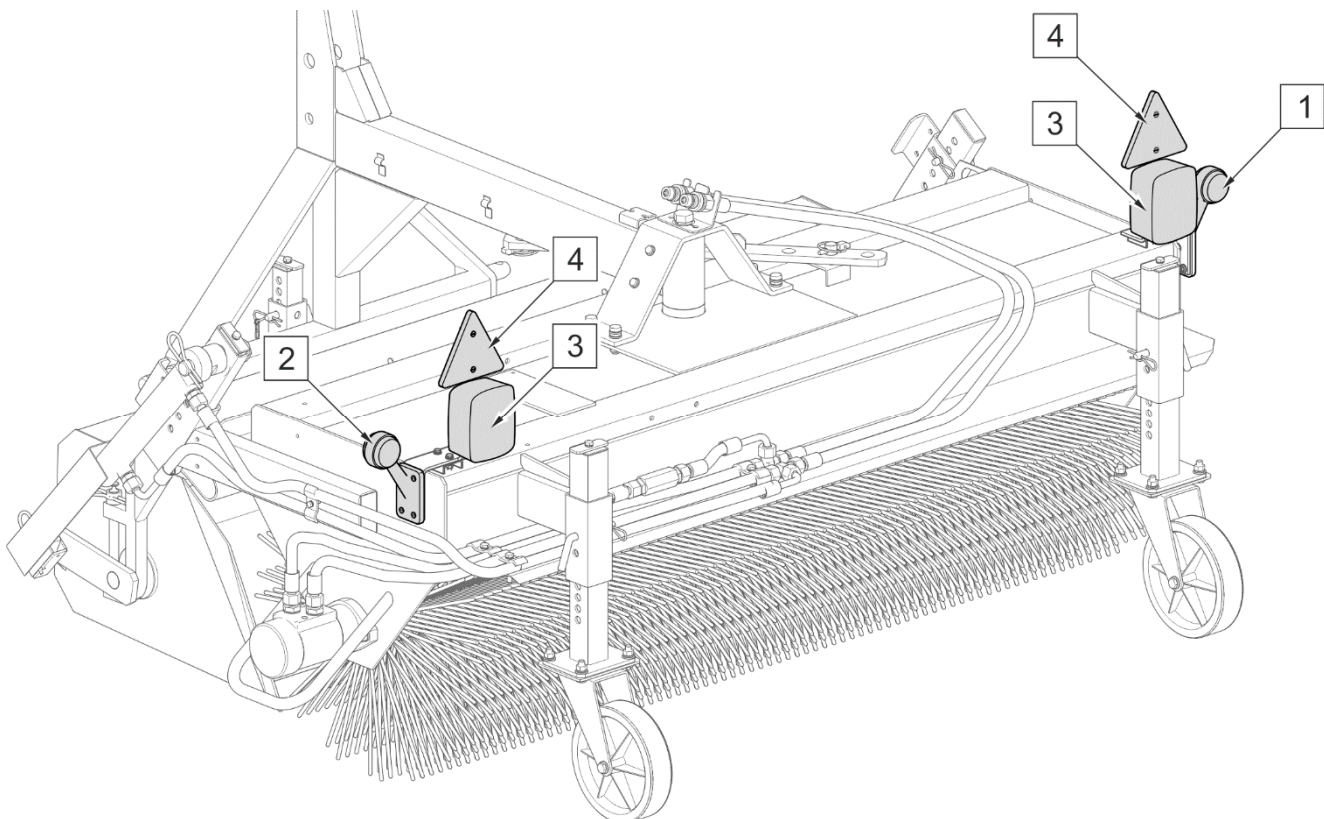


**FIGURE 4.9 Additional bracket for the warning sign (option)**

(1) - bracket; (2) - slow-moving vehicle warning sign (not included in the machine equipment)



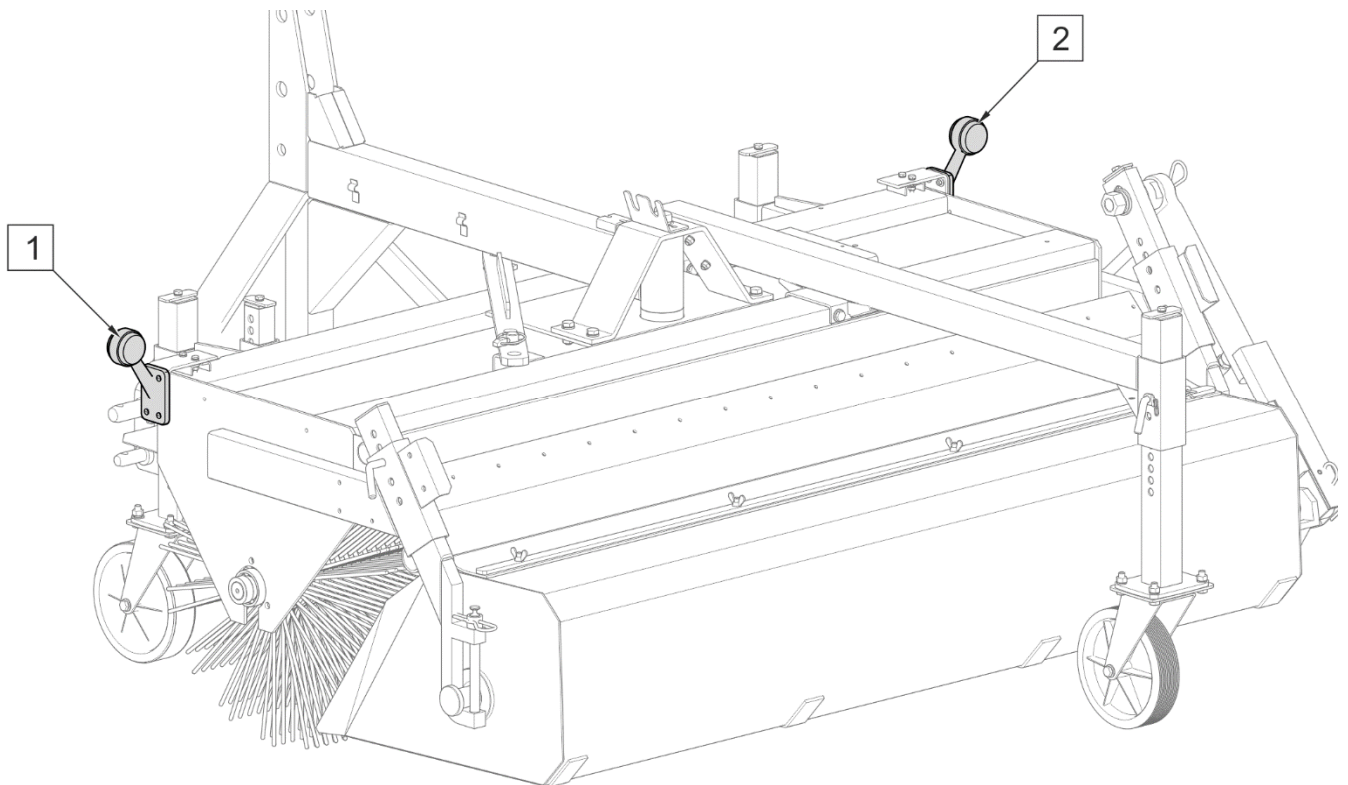
- Additional lights (FIGURE 4.10) should be used if the sweeper obscures the lights installed at the back of the carrying vehicle. The lights (FIGURE 4.11) should be used for the front-mounted sweeper.
- Avoid ruts, depressions, ditches or driving on roadside slopes. Driving across such obstacles could cause the machine and the carrying vehicle to suddenly tilt. Driving near ditches or canals is dangerous as there is a risk of the wheels sliding down the slope or the slope collapsing.
- Speed must be sufficiently reduced before making a turn or driving on an uneven road or a slope.
- When driving on uneven terrain with the implement raised reduce speed due to dynamic loads and the risk of damaging the machine or carrying vehicle.
- When driving with raised machine set it so as not to obscure the lights or restrict the visibility of the operator.
- When driving with raised machine, secure the carrying vehicle's linkage against falling or accidental lowering.



**FIGURE 4.10 Additional lights for the rear-mounted sweeper**

(1) - right clearance lamp; (2) - left clearance lamp; (3) - lamp assembly; (5) - reflective warning triangle





**FIGURE 4.11 Additional lights for the front-mounted sweeper**

*(1) - right clearance lamp; (2) - left clearance lamp*

## 4.6 UNHITCHING THE MACHINE FROM THE CARRYING VEHICLE



### **DANGER**

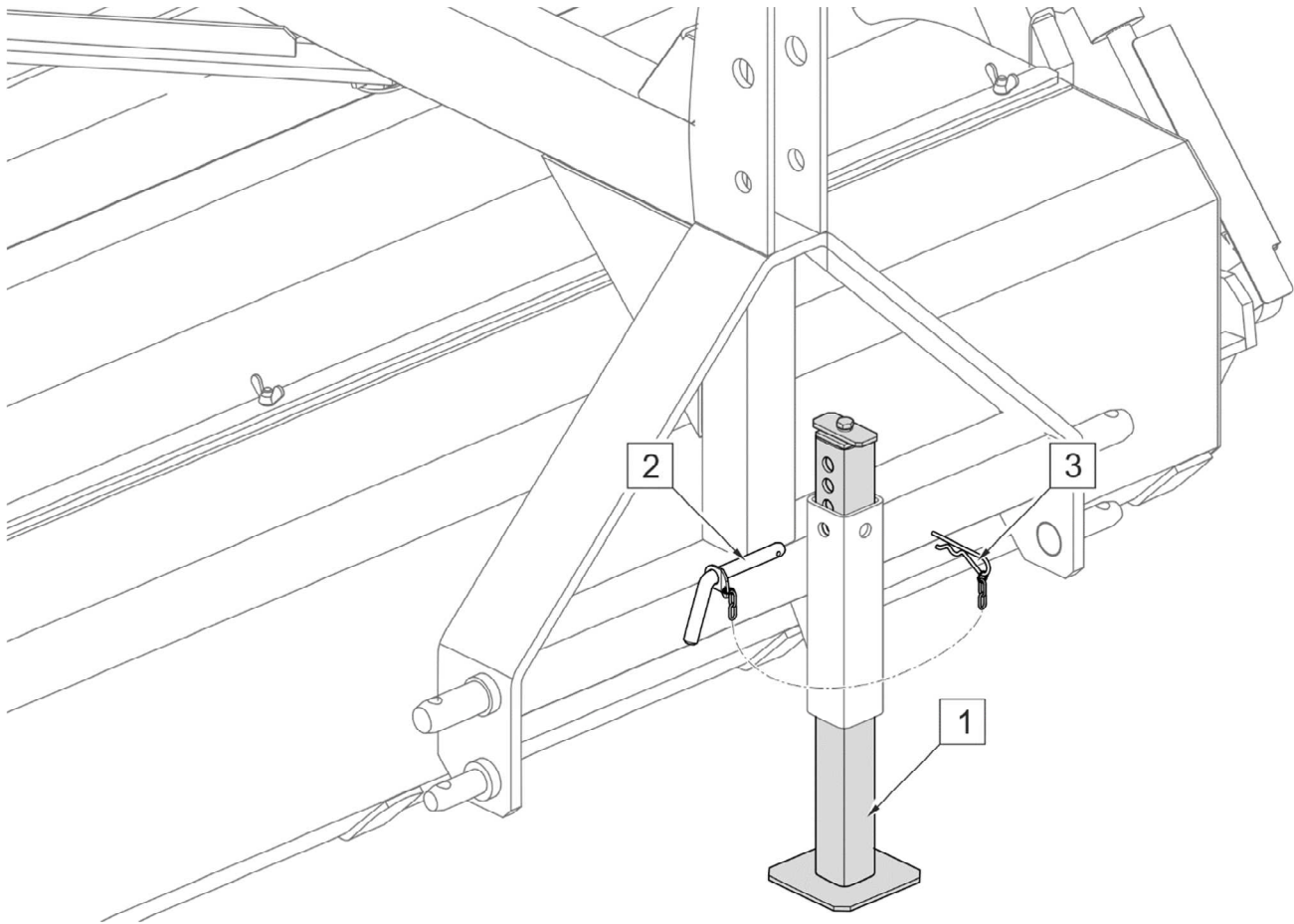
Before unhitching the machine from the carrying vehicle, turn off the carrying vehicle's engine, engage parking brake and secure cab against access of third persons.

The sweeper unhitched from the carrying vehicle should be supported on a parking stand (FIGURE 4.12) and on two jockey wheels or on three jockey wheels (if an additional front wheel is installed). If the sweeper's roller brush rests on the ground, the brush bristle may get deformed.



### **DANGER**

Reduce pressure prior to disconnecting the hydraulic system.

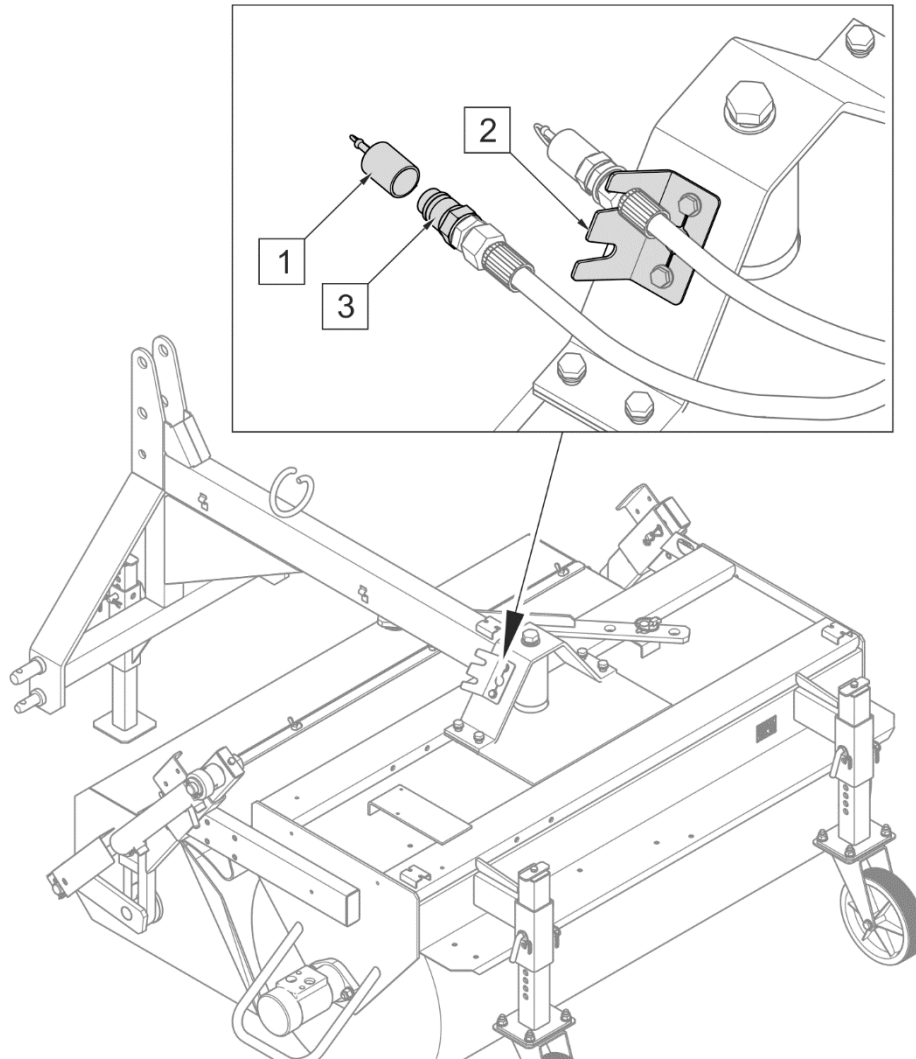


**FIGURE 4.12 Parking stand**

(1) - parking stand, (2) - linchpin, (3) - securing cotter pin

In order to disconnect the sweeper from the carrying vehicle, proceed as follows:

- When the machine is raised, lower the parking stand (1) and set it at a proper height (FIGURE 4.12).
- Lower the sweeper until it fully rests on the ground.
- Switch off engine, remove key from ignition and engage parking brake.
- Reduce residual pressure in the hydraulic system by moving appropriate lever controlling the carrying vehicle's hydraulic circuit.
- Disconnect hydraulic conduit plugs and electric lead plugs (if any) from the carrying vehicle and secure with stoppers. Place hydraulic conduit plugs in the special bracket on the frame (FIGURE 4.13).
- Disconnect the linkage and drive the carrying vehicle away from the machine.



**FIGURE 4.13** Protection of plugs after disconnection from the carrying vehicle  
(1) - stoppers of hydraulic quick-couplers; (2) - bracket; (3) - hydraulic quick-coupler



***SECTION***

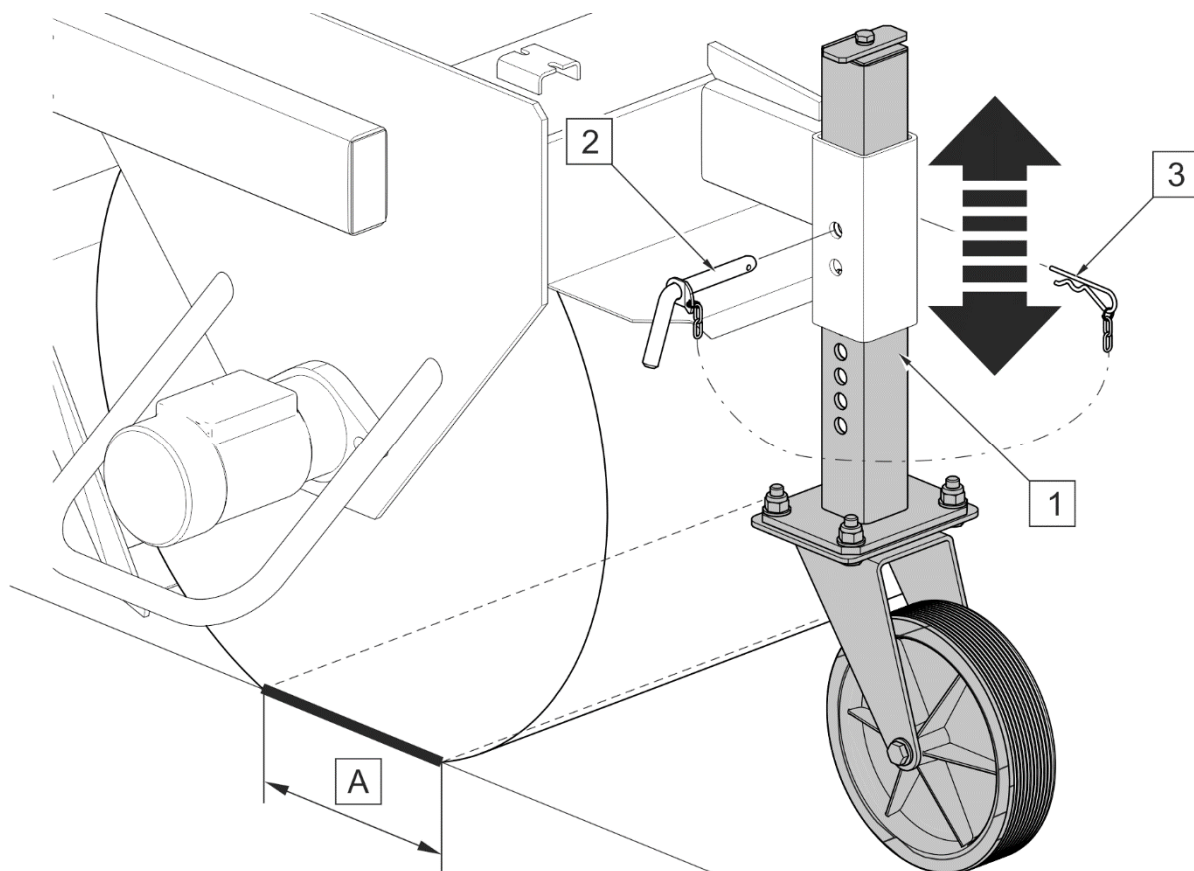
**5**

---

**MAINTENANCE**

## 5.1 ADJUSTMENT OF ROLLER BRUSH

Adjustment of roller brush should be always made in combination with adjustment of waste tank (this does not apply to the sweeper without waste tank). When setting the brush, take its wear into account. The roller brush ground contact surface (FIGURE 5.1) should be within A range (from 60 to 120 mm). The pressure can be set individually depending on the degree of ground contamination.



**FIGURE 5.1** Adjustment of roller brush pressure

(1) - jockey wheel; (2) - linchpin; (3) - securing cotter pin; (A) - brush ground contact surface (60-120 mm)

Brush pressure is adjusted by changing the position of jockey wheels (1) in guides (FIGURE 5.1) as follows:

- raise the sweeper mounted on the carrying vehicle, turn off the engine and engage the parking brake,
- remove securing cotter pin (3) and linchpin (2),
- raise or lower the wheel (1) in the guide so that the holes are coaxial,

- insert linchpin (2) into the corresponding hole and secure with cotter pin (3),
- adjust the height of the second wheel in the same way (and the height of the front jockey wheel - if installed)

After adjustment, lower the sweeper on the jockey wheels and check the width of the brush ground contact surface, adjust again if necessary. Also, pay attention to levelling of the sweeper (e.g. by means of the top link of three point linkage, so-called central connector).

While adjusting the roller brush pressure make sure the contact surface is uniform along the entire length of the brush. Uneven adjustment of the brush pressure on the right and left side of the machine causes uneven wear of the brush. Check the height of suspended waste tank and, if necessary, adjust after each adjustment of the jockey wheels.

## 5.2 ADJUSTING THE WASTE TANK

Adjust the waste tank (FIGURE 5.2) after adjusting the pressure of the roller brush and adjusting the waste tank inclination angle. Adjust the height of the waste tank as follows:

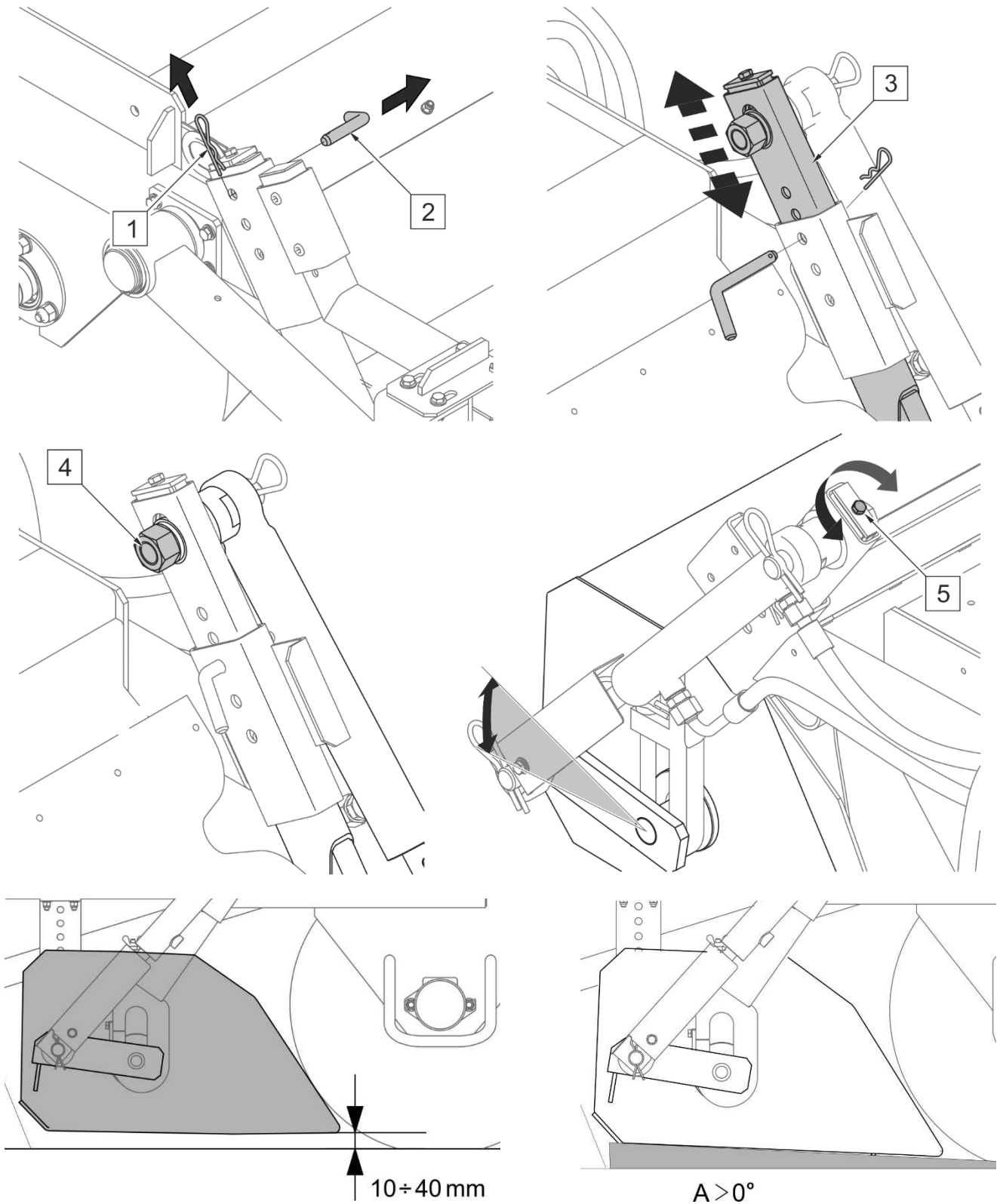
- lower the sweeper on the jockey wheels and set it horizontally,
- remove cotter pin (1) from safety pin (2) and remove the pin from the guide hole on the right side of the sweeper,
- while sliding out the arm (3), set the tank at a height between 10 and 40 mm from the ground,
- insert safety pin (2) into the matching through hole in the guide

Proceed the same way to adjust the height of the tank on the left side of the sweeper. The distance of the tank from the ground on the left and right side of the sweeper must be the same.

To adjust waste tank tilt angle (FIGURE 5.2) move the upper anchorage point of the waste tank tipping cylinder on the left side of the sweeper. The adjustment should be performed as follows:

- loosen nut (4) fastening the cylinder pin,
- screw in or unscrew the adjustment bolt (5) to set the inclination angle of the waste tank so that angle (A) between the bottom of the tank and the ground is positive, the greater value of the angle (A) should be used for uneven surfaces,

- tighten nut (4) of the cylinder pin and tighten bolt (5).



**FIGURE 5.2 Adjusting the waste tank**

(1) - securing cotter pin; (2) - pin; (3) - arm; (4) - nut; (5) - adjustment bolt

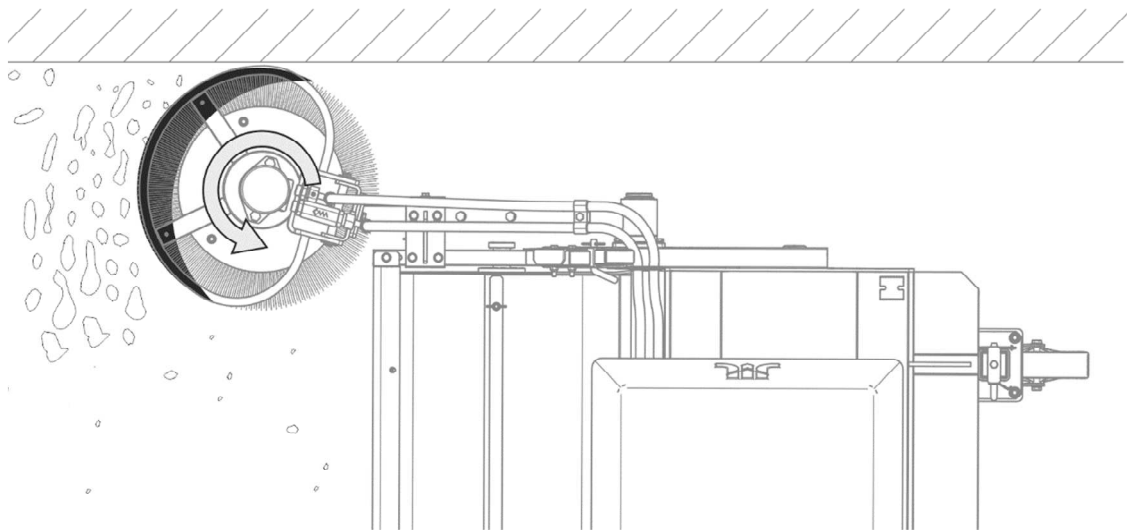
Perform the adjustment with the waste tank tipping cylinder maximally extended.



After adjusting the waste tank, check that all fixing bolts and securing elements are properly fitted. Monitor the setting of the waste tank as the roller brush wears down.

### 5.3 ADJUSTING THE SIDE BRUSH

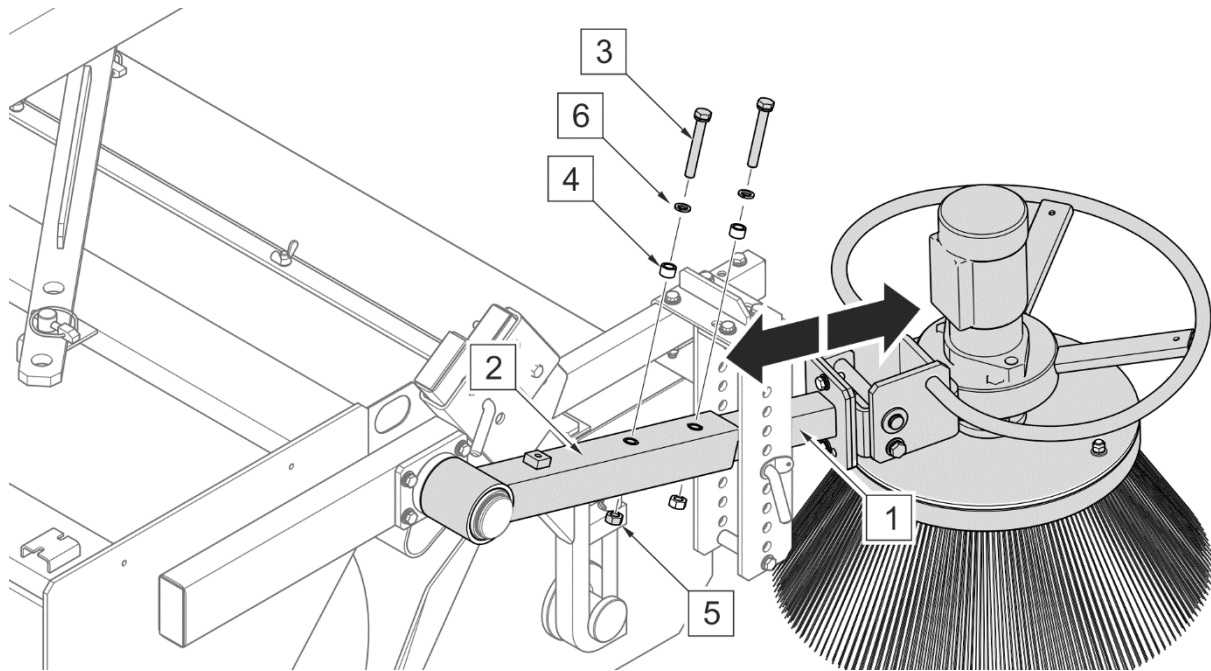
All adjustments of the side brush head are performed after adjusting the roller brush and waste tank, depending on the amount of dirt on the surface being swept and the degree of wear of the head.



**FIGURE 5.3** Correct setting of the side brush

Correctly positioned side brush head should touch the surface only with a section of its circumference in such a manner as to ensure that waste is directed to the inside of the sweeper, in front of the roller brush. Shaded areas on the diagram (FIGURE 5.3) indicate sections of correctly set brushes which touch the surface.

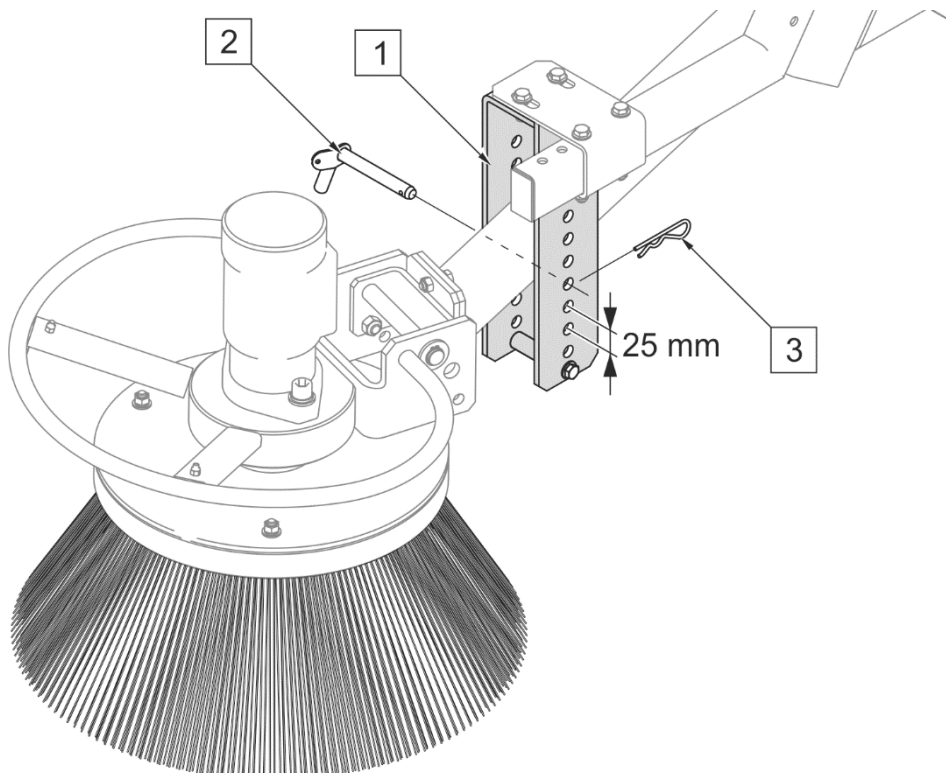
The length of the brush arm (FIGURE 5.4) can be changed within the range of 150 mm by steps of 50 mm. To make the adjustment, undo nuts (5), remove bolts (3) and slide arm (1) out from guide (2) to a proper length and secure the arm again with bolts and nuts.



**FIGURE 5.4 Adjustment of brush arm length**

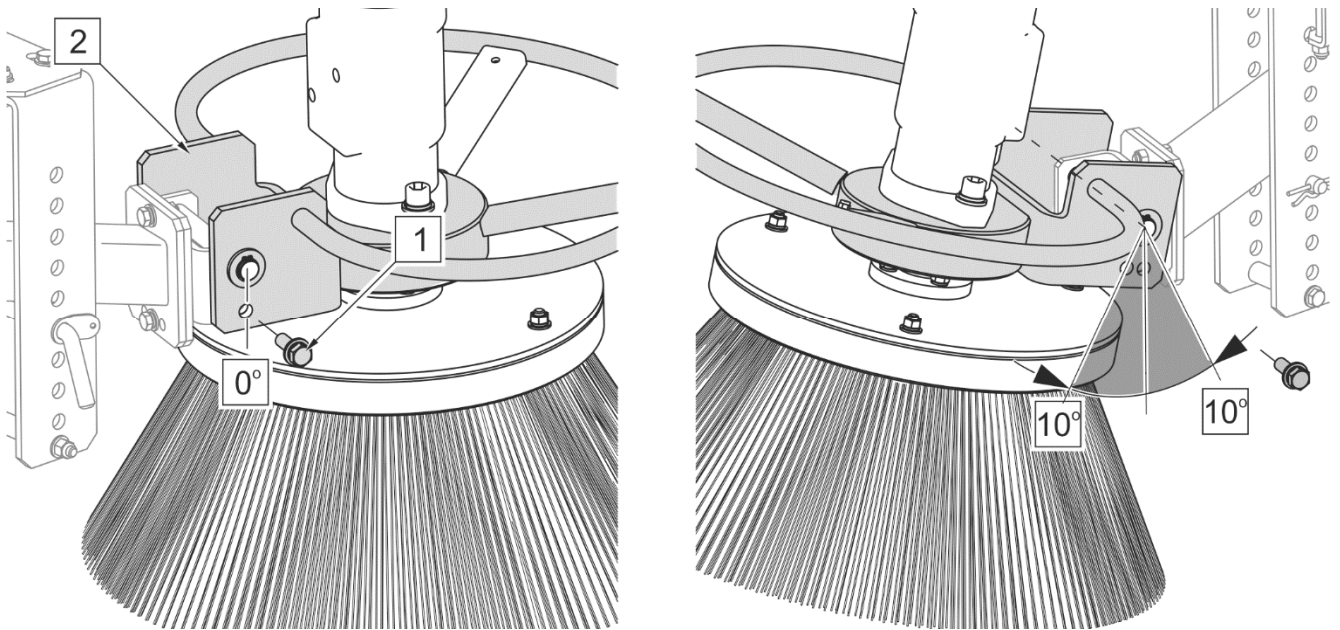
(1) - brush arm; (2) - guide; (3) - M10x70 bolt; (4) - sleeve; (5) - M10 nut; (6) - 10.2 spring washer

To set the brush pressure (FIGURE 5.5), remove cotter pin (3) and change pin (2) mounting hole in bracket (1) and secure with cotter pin (3).



**FIGURE 5.5 Adjusting side brush pressure**

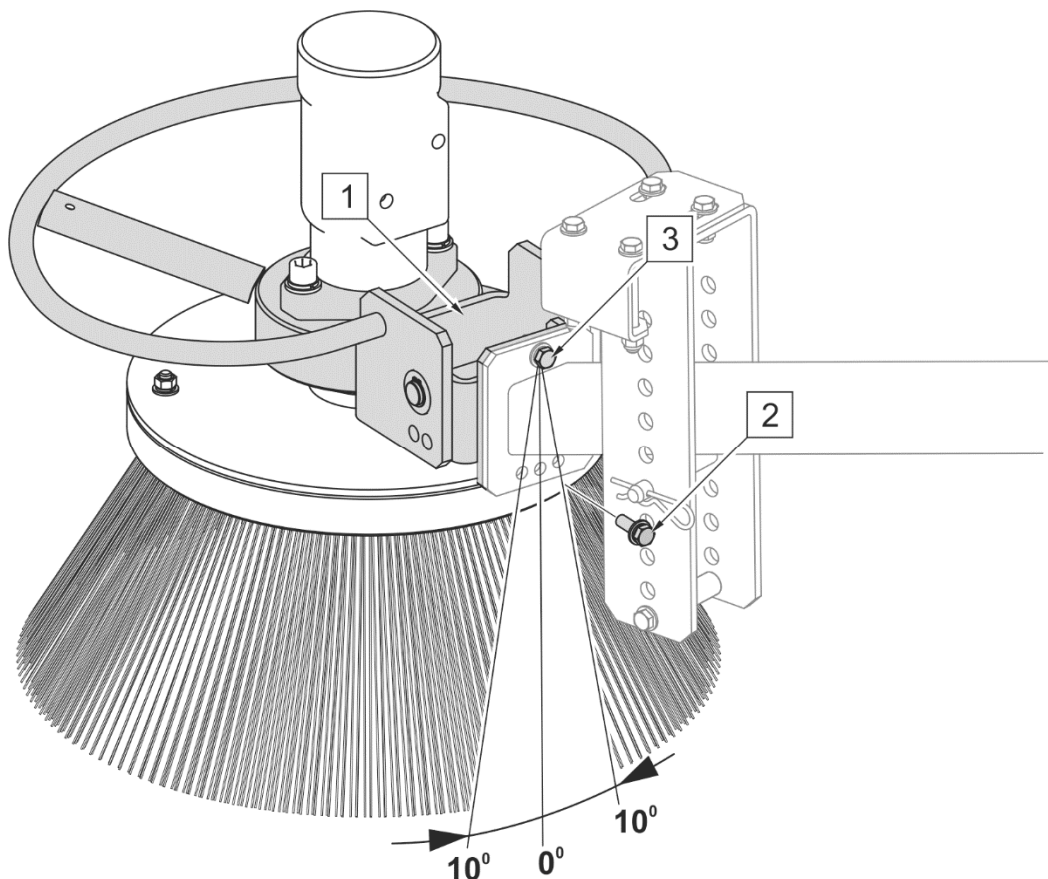
(1) - brush arm guide, (2) - pin, (3) - securing cotter pin



**FIGURE 5.6** Adjusting longitudinal tilt

(1) - longitudinal tilt retaining bolt, (2) - brush head bracket

Longitudinal tilting of the head can be set in three positions (FIGURE 5.6). This involves changing the position of retaining bolt (1) in head bracket holes (2).



**FIGURE 5.7** Adjusting lateral tilt

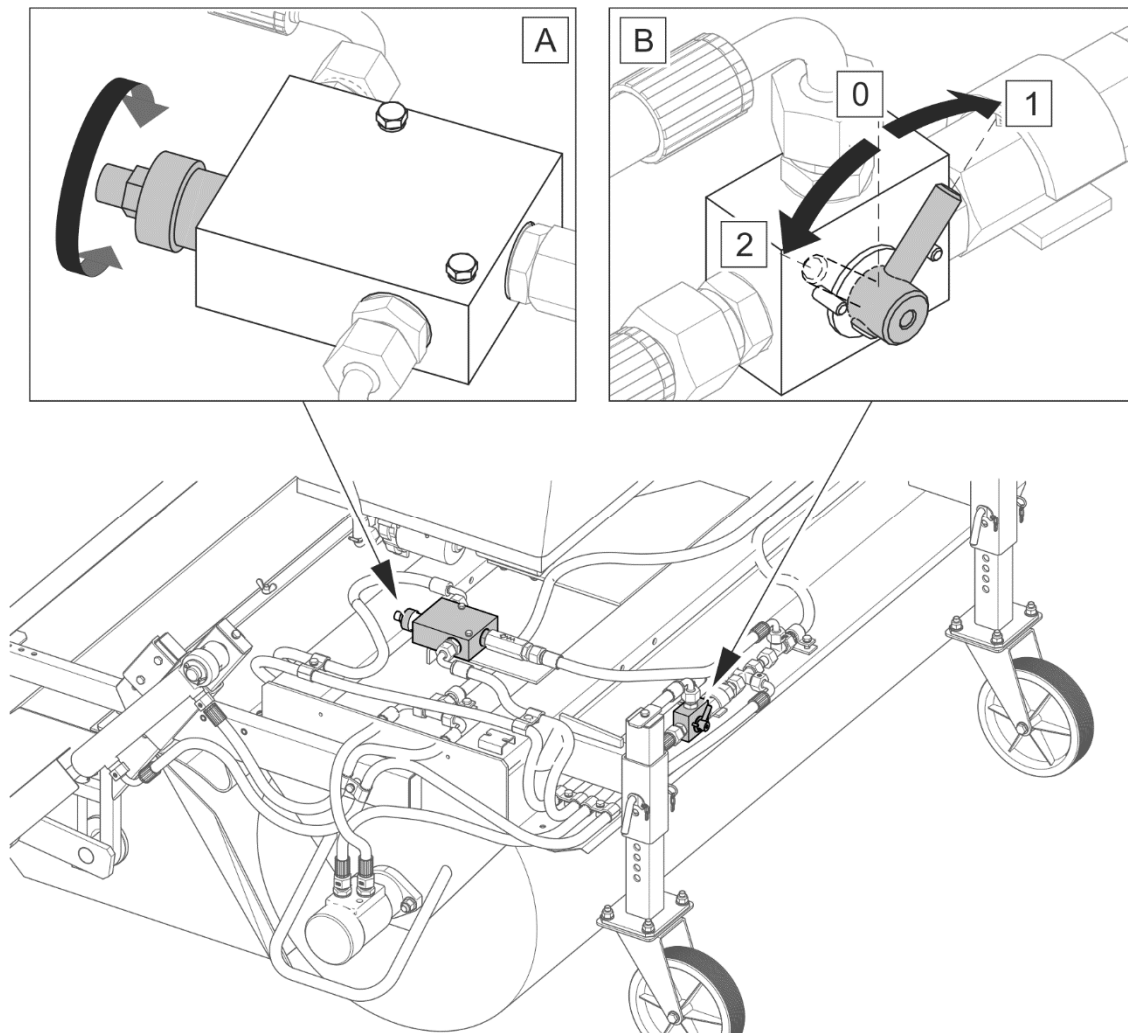
(1) - brush head bracket, (2) - retaining bolt, (3) - fixing bolt

To change the lateral tilt angle (FIGURE 5.7), remove retaining bolt (2), loosen fixing bolt (3) and turn bracket (1) to the right or left side so as to place bolt (2) in the corresponding hole. Tighten fixing bolt (3) after the adjustment of lateral tilt of side brush.

The sweepers with side brush (FIGURE 5.8) are equipped with oil flow regulator (A) for smooth adjustment of the side brush rotation speed. Rotation speed is controlled using the knob on the oil flow regulator.

Distributor (B) (FIGURE 5.8) makes it possible to:

- Switch off the brush drive (position 0),
- Switch on the roller brush only (position 1),
- Switch on the drive of both brushes (position 2)



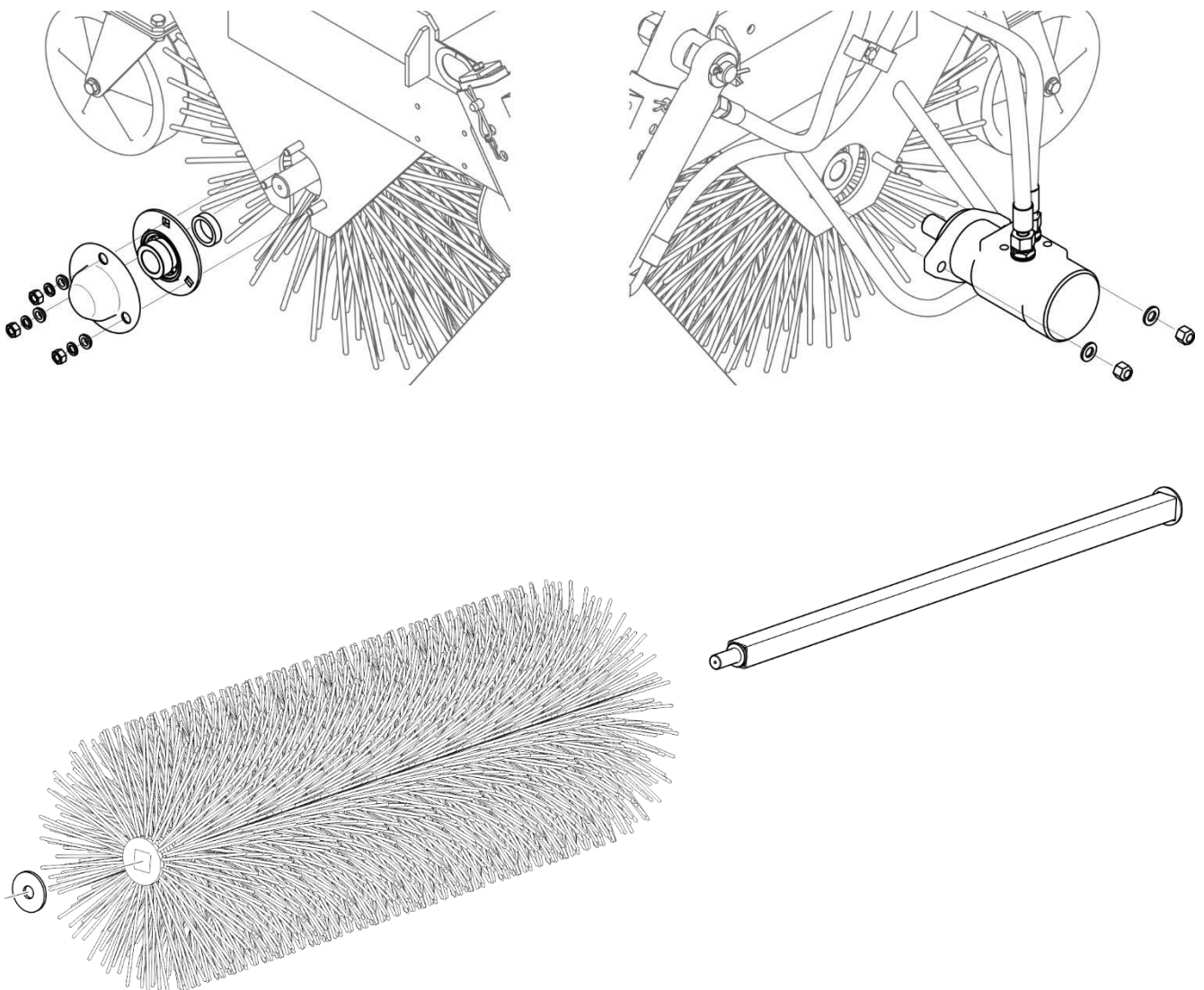
**FIGURE 5.8 Brush flow regulator and drive distributor**

(A) - oil flow regulator; (B) - brush drive distributor; (0) - drive of both brushes is off; (1) - only the roller brush drive is on; (2) - drive of both brushes is on

## 5.4 INSPECTION AND REPLACEMENT OF ROLLER BRUSH

Excessively worn or damaged brush should be replaced. Before replacing the roller brush, make sure that the sweeper is disconnected from the carrying vehicle's hydraulic system and that the residual pressure in the hydraulic system is reduced.

The brush consists of one segment installed on the shaft (FIGURE 5.9). Brushes having various parameters and designed for various applications are available depending on the customer's requirements. List of brushes is shown in 0



**FIGURE 5.9** Replacing the roller brush



Technical condition of the sweeper's brush should be inspected regularly while using the machine.

**TABLE 5.1** Types of roller brushes

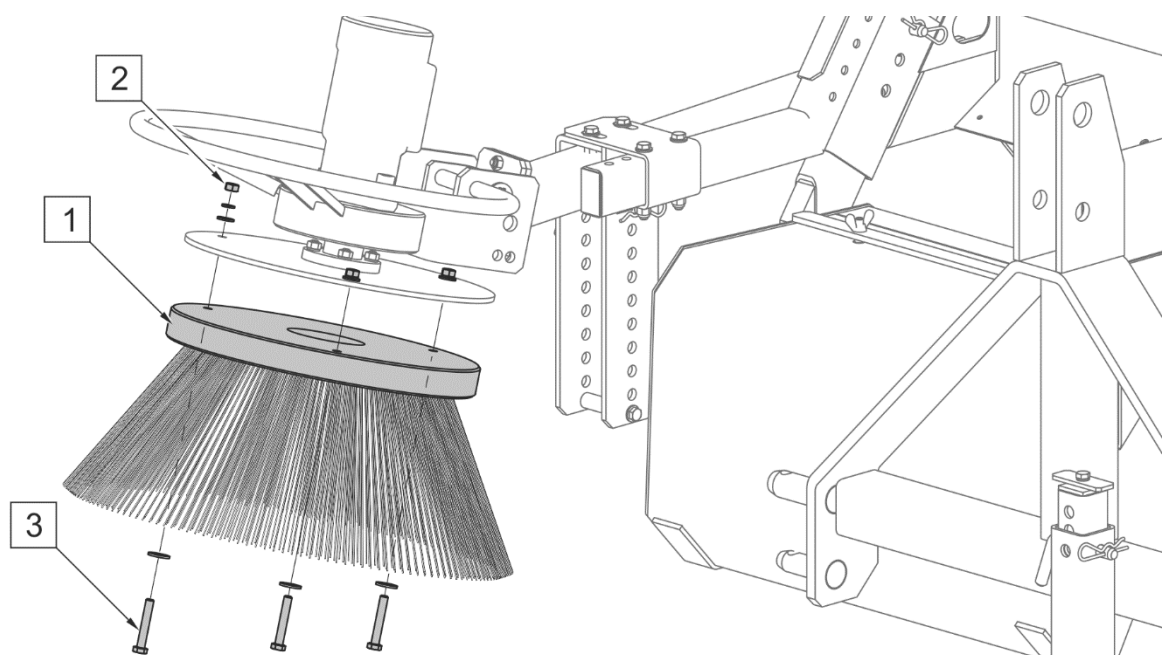
ITEM	SPECIFICATION	PART NUMBER
1	Soft brush ( <i>plastic 1.6mm</i> )	472N-00000003
2	Medium brush ( <i>plastic 2x3mm</i> )	472N-00000003-01
3	Hard brush ( <i>plastic 1.6mm+wire 0.5mm</i> )	472N-00000003-02
4	Very hard brush ( <i>plastic 2x3mm+wire 0.5mm</i> )	472N-00000003-03

## 5.5 REPLACING THE SIDE BRUSH

Excessively worn or damaged brush should be replaced. The side brush replacement may only be performed when the sweeper is unhitched from the carrying vehicle and supported on the ground. The side brush arm should be raised and locked in the guide in its highest position.

To replace the side brush:

- undo nuts (2), remove bolts (3) with washers;
- replace worn brush (1),
- insert bolts (3) and washers and tighten nuts (2);



**FIGURE 5.10** Replacing the side brush

(1) - brush, (2) - M8 Nut, (3) - M8x50 bolt

**TABLE 5.2 The types of side brushes**

ITEM	SPECIFICATION	PART NUMBER
1	Medium brush ( <i>flat wire + plastic 2x3 mm</i> )	260800.900600
2	Soft brush ( <i>plastic 2x3 mm</i> )	260800.000600
3	Hard brush ( <i>flat wire</i> )	260800.900000

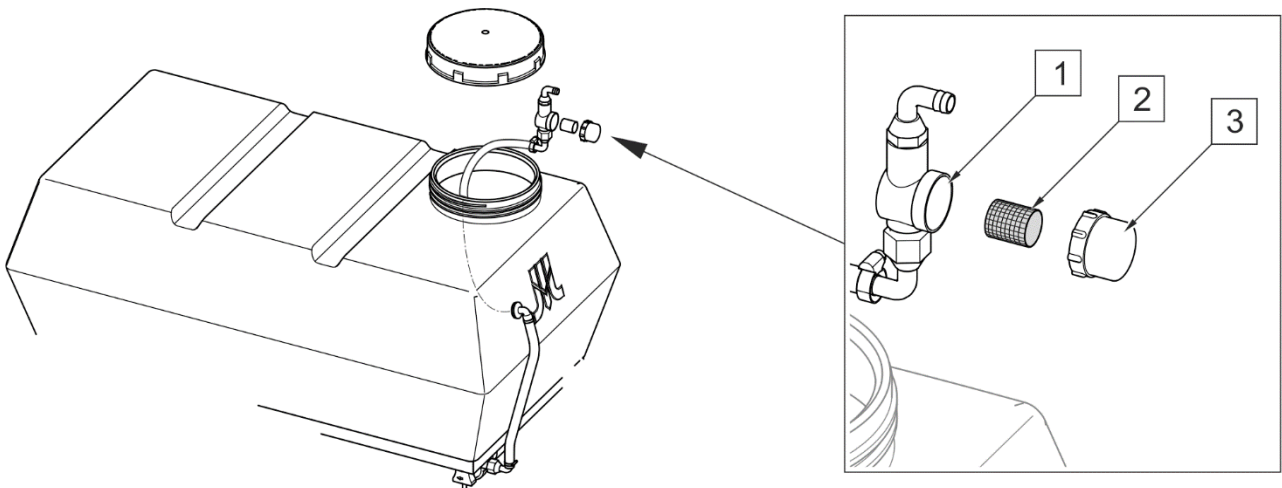
## 5.6 SPRINKLER SYSTEM MAINTENANCE

Maintenance of the sprinkler system involves periodic inspection of the system and cleaning of water filters.

Before first use, check sprinkler operation, especially the setting of spray nozzles. Nozzles should be positioned so that during sweeper operation water is sprayed through the slit perpendicularly to the sweeping direction.



Technical condition of the sprinkler system should be inspected regularly while using the machine. Frequency of filter cleaning depends on amount and size of water contamination.

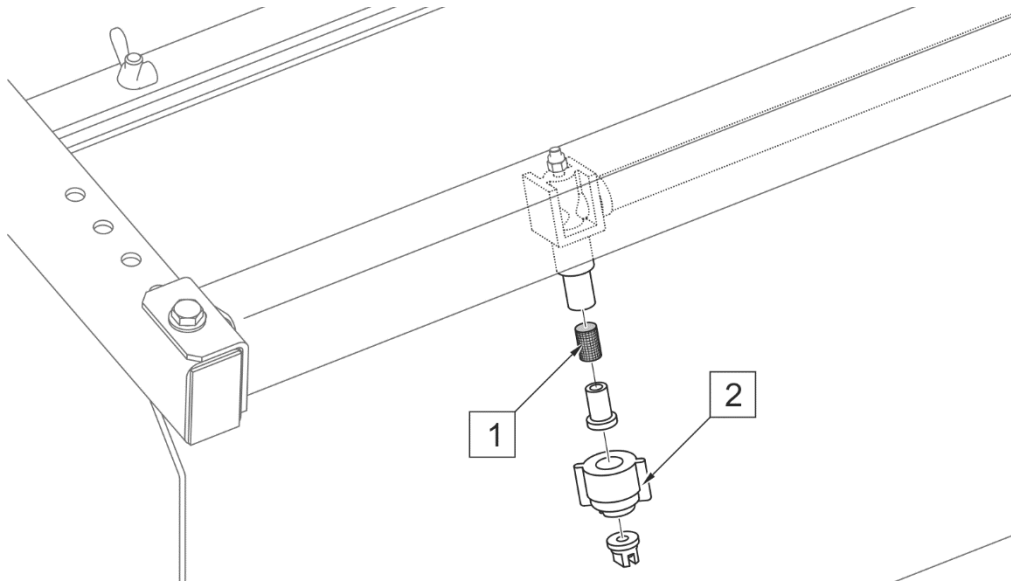
**FIGURE 5.11 Filter in water tank**

(1) - filter housing; (2) - mesh cartridge; (3) - cover

In the tank there is a water filter (FIGURE 5.11) installed on suction conduit (*applies to pump with part number 2095-161-2401*). In order to clean the filter, take it out together with the conduit through the tank opening, unscrew cover (3), remove mesh cartridge (2) and wash it with water under pressure or clean with compressed air. Install cartridge, tighten filter

housing and check tightness of connection. In case of pump with part number 8411001, the water filter is installed next to the pump.


There is a filter (FIGURE 5.12) inside each sprinkler. In order to clean the sprinkler filter (1), undo nut (2) and wash or blow the filter with compressed air. Before installing, make sure the sprinkler nozzle is not clogged. Check technical condition of sprinklers and, if necessary, replace them.




**FIGURE 5.12 Filters of sprinklers**

(1) - filter; (2) - nut

If sprinkler electrical system fails, first check water level in the tank and if filters are clean and the correct connection of the control cable with the switch and water pump power cable.

	<p><b>NOTE</b></p> <p>If there is a leakage in the sprinkler system, water is sprayed in a wrong manner.</p>
---	--

	<p><b>ATTENTION</b></p> <p>If temperature drops below 0°C, the machine should be stored in a building at a temperature above 0°C, because there is a risk that water in the water pump will freeze and damage the pump. Do not start frozen water pump.</p> <p>If the machine must be stored in temperatures below 0°C, drain water from the tank and the connector pipes and blow the water pump through with compressed air.</p>
---	--



## 5.7 HYDRAULIC SYSTEM OPERATION

The duties of the operator connected with the hydraulic system include:

- checking tightness of cylinder and hydraulic connections,
- checking technical condition of hydraulic conduits and quick couplers;



### **DANGER**

**Do not repair hydraulic system on your own. All hydraulic system repairs must be performed only by suitably qualified personnel.**



### **DANGER**

**Before commencing whatever work on hydraulic system reduce the pressure in the system.**



### **DANGER**

**During work on hydraulic system, use the appropriate personal protection equipment i.e. protective clothing, footwear, gloves and eye protection. Avoid contact of skin with oil.**

The hydraulic system of new sweeper is factory filled with HL32 hydraulic oil. Because of its composition the oil applied is not classified as a dangerous substance, however long-term action on the skin or eyes may cause irritation. In the event of contact of oil with skin wash the place of contact with water and soap. Do NOT apply organic solvents (petrol, kerosene). Contaminated clothing should be changed to prevent access of oil to skin. In the event of contact of oil with eye, rinse with large quantity of water and in the event of the occurrence of irritation consult a doctor. Hydraulic oil in normal conditions is not harmful to the respiratory tract. A hazard only occurs when oil is strongly atomised (oil vapour), or in the case of fire during which toxic compounds may be released.



**Hydraulic conduits should be replaced after 4 years of machine use.**



### **DANGER**


**Oil fires should be quenched with carbon dioxide (CO<sub>2</sub>), foam or extinguisher steam. Do NOT use water for fire extinguishing!**

Spilt oil should be immediately collected and placed in a marked tight container. Used oil should be taken to the appropriate facility dealing with recycling or regeneration of oils.

**TABLE 5.3 HL32 hydraulic oil characteristics**

ITEM	NAME	VALUE
1	ISO 3448VG viscosity classification	32
2	Kinematic viscosity at 40°C	28.8 – 35.2 mm <sup>2</sup> /s
3	ISO 6743/99 quality classification	HL
4	DIN 51502 quality classification	HL
5	Flash point, °C	Above 210°C
6	Maximum operating temperature, °C	80


The hydraulic system should be completely tight sealed. Inspect the seals when the hydraulic cylinder is completely extended. If oil is found on hydraulic cylinder body, check origin of leak. Minimum leaks are permissible with symptoms of "sweating", however in the event of noticing leaks in the form of "droplets" stop using the machine until faults are remedied.



**NOTE**


Before you begin to operate the sweeper, visually inspect the hydraulic system components.

In the event oil leak is detected in hydraulic line connections, tighten the connections, and if this does not remedy the problem, replace the leaking hydraulic line or connection. Always exchange each mechanically damaged component.



**NOTE**

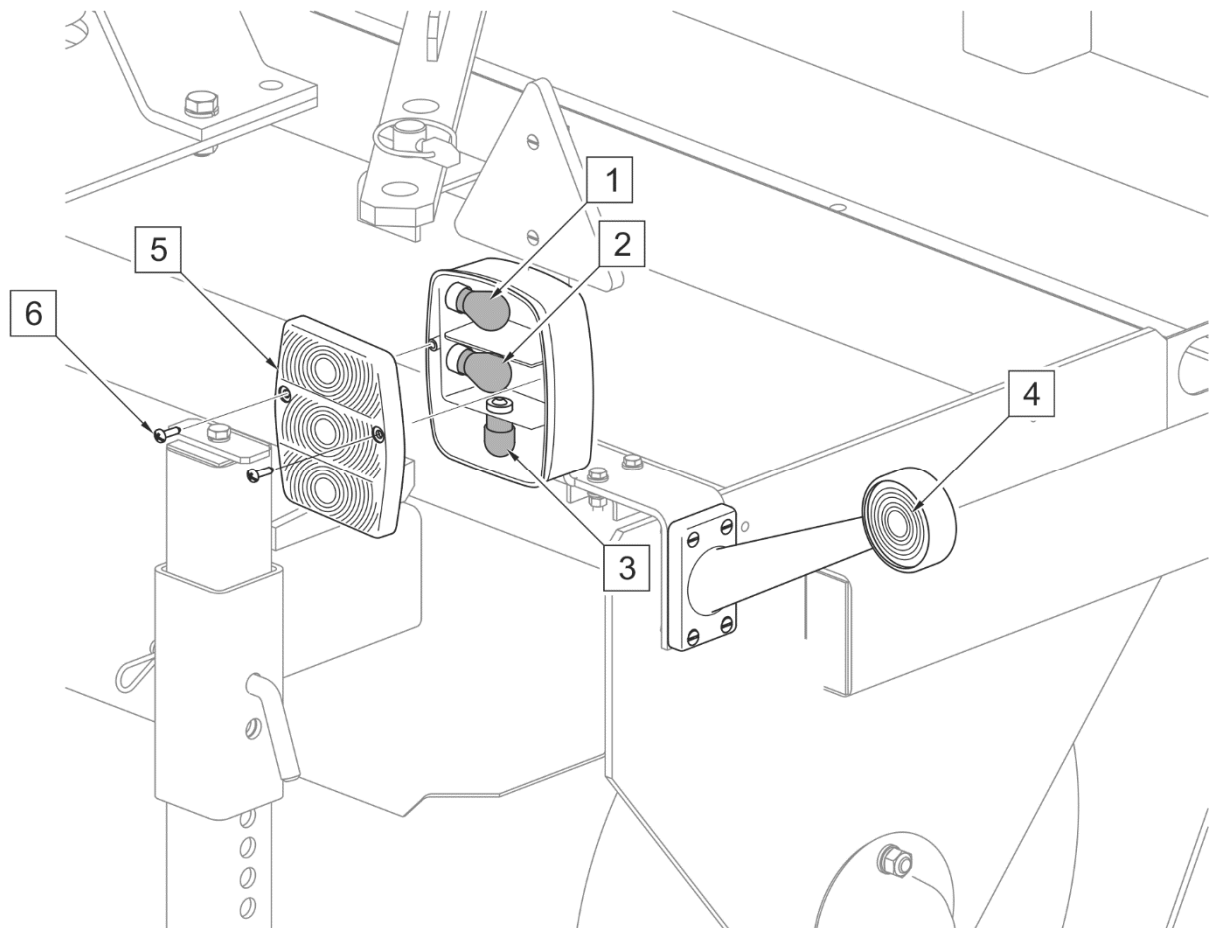
The hydraulic system is vented automatically during machine operation.



The condition of hydraulic system should be inspected regularly while using the machine.

## 5.8 ELECTRICAL SYSTEM MAINTENANCE

Electrical system maintenance is conducted during the periodical checking the operation of sprinkler and lighting system (option).



**FIGURE 5.13 Replacement of bulbs**

(1) - indicator light bulb; (2) - brake light bulb; (3) - parking light bulb; (4) - LED clearance lamp; (5) - lamp assembly lens; (6) - screw

After connecting to 7-pole socket on the tractor, check operation of the lighting system. In case of bulb burnout in lamp assembly, unscrew screws (6) that secure lamp lens (5) and replace appropriate bulb (FIGURE 5.13). The clearance lights (4) are maintenance-free LED lights.

**TABLE 5.4 List of bulbs**

MARKING (FIGURE 5.13)	TYPE OF LIGHT	BULB	LAMP
1	indicator light	P21W	Lamp assembly W-18U
2	brake light	P21W	
3	parking light	R10W	
4	clearance light	-	Left clearance lamp 295BCL Right clearance lamp 295BCP



**DANGER**

Do not independently repair electrical system, except items described in chapter ELECTRICAL SYSTEM MAINTENANCE. All electrical system repairs must be performed only by suitably qualified personnel.

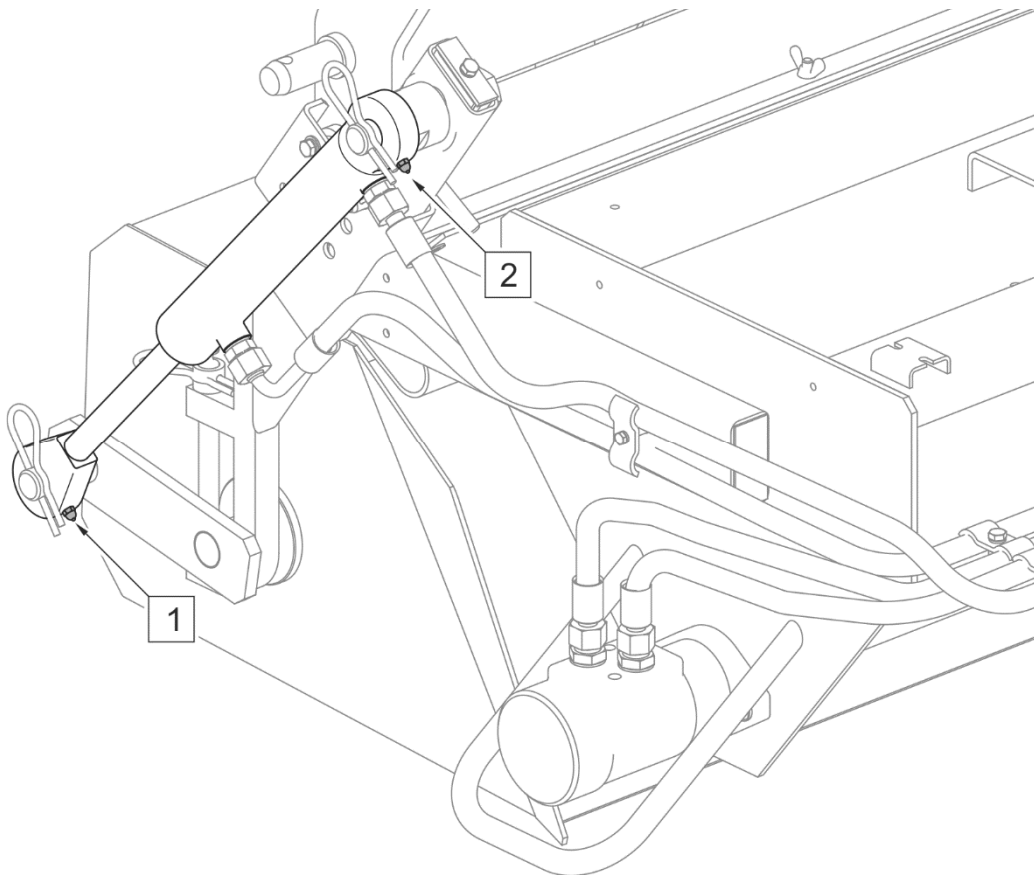
**5.9 LUBRICATION**

Machine lubrication should be performed with the aid of a manually or foot operated grease gun, filled with ŁT-43-PN/C-96134 grease.

After lubricating according to instructions, wipe off excess grease.



When using the machine the user is obliged to observe lubrication instructions according to attached schedule. Excess lubrication substance causes depositing additional contaminants in places requiring lubrication, therefore it is essential to keep individual machine elements clean.



**FIGURE 5.14 Lubrication points**

Lubrication points are detailed in Table TABLE 5.5

**TABLE 5.5 LUBRICATION POINTS AND LUBRICATION FREQUENCY**

ITEM	NAME	NUMBER OF LUBRICATION POINTS	TYPE OF GREASE	LUBRICATION FREQUENCY
1	Cylinder rod lug	1	grease	50 hours
2	Cylinder barrel lug	1		

*Marking description in Item column (TABLE 5.5) conforms with numbering shown (FIGURE 5.14)*

## 5.10 STORAGE

After finishing work, machine should be thoroughly cleaned and washed with water jet. While washing do not direct a strong water jet at information and warning decals, hydraulic cylinders, electrical equipment. In the event of damage to the lacquer coating clean those places from rust and dirt, degrease and then paint with paint maintaining uniform colour and even thickness of protective coating. Until the time of touch-up painting, the damaged place

may be covered with a thin layer of grease or anti-corrosion preparation. It is recommended to keep the machine in a closed or roofed building.

If the machine shall not be used for a long period of time, protect it against adverse weather conditions. Lubricate machine according to the instructions provided. In the event of prolonged work stoppage, it is essential to lubricate all elements regardless of the date of the last lubrication. Additionally before the winter period apply grease to hitching system pins and openings.


If there is a risk that temperatures drop below 0°C, drain water from the sprinkler system and blow the system through with compressed air.

### 5.11 TIGHTENING TORQUE FOR NUT AND BOLT CONNECTIONS

Unless other tightening parameters are given, during maintenance repair work apply appropriate torque to tightening nut and bolt connections. Recommended torque values (TABLE 5.6) apply to non-greased steel bolts.

**TABLE 5.6 TIGHTENING TORQUE FOR NUT AND BOLT CONNECTIONS**

THREAD DIAMETER [mm]	5.8	8.8	10.9
	TIGHTENING TORQUE [Nm]		
M6	8	10	15
M8	18	25	36
M10	37	49	72
M12	64	85	125
M14	100	135	200
M16	160	210	310
M20	300	425	610
M24	530	730	1050
M27	820	1150	1650



**NOTE**

Should it be necessary to change individual parts, use only original parts or those indicated by the Manufacturer. Non-adherence to these requirements may put the user and other people's health and life at risk, and also cause damage to the machine.

## 5.12 TROUBLESHOOTING

**TABLE 5.7 Troubleshooting**

<b>TYPE OF FAULT</b>	<b>CAUSE</b>	<b>REMEDY</b>
The roller brush does not rotate or rotates in the wrong direction	Hydraulic system not connected or incorrectly connected	Check connection
	Wrong carrying vehicle's hydraulic circuit activated or hydraulic circuit not activated	Activate correct hydraulic circuit in the carrying vehicle
	Faulty hydraulic system	Notify service point
Side brush does not rotate	Hydraulic system not connected or incorrectly connected	Check connection
	Side brush drive turned off	Turn on the brush drive distributor
	Faulty hydraulic system	Notify service point
Side brush rotates too slowly or too quickly	Sweeper oil flow regulator improperly adjusted	Set brush rotation speed by turning the oil flow regulator knob
Waste tank can not be opened or closed	Hydraulic system not connected or incorrectly connected	Check connection
	Wrong carrying vehicle's hydraulic circuit activated or hydraulic circuit not activated	Change the direction of oil flow in the hydraulic circuit using the manifold lever in the carrying vehicle
Sprinkler system is not working	Sprinkler system turned off	Set the sprinkler system switch to "on" position
	Water pump electrical power supply not connected	Check the connection of the power lead plug. Check the connection of the sprinkling system switch
	No water in the tank	Top up water
	Sprinkler system clogged	Make sure the system is not clogged, clean the filter strainers and water sprinklers
	Faulty water pump	Notify service point
Sweeper does not collect waste precisely	The roller brush rotation speed is too low	Increase engine RPM
	Pressure applied to the surface by the roller brush is incorrectly set	Adjust according to operator's manual
	Waste tank positioned incorrectly	Adjust according to operator's manual
	Side brush incorrectly set	Adjust according to operator's manual
	Excessive driving speed	Adjust driving speed
	Waste tank is full	Empty the waste tank
Rapid wear of brushes	Brushes excessively worn	Replace
Rapid wear of brushes	Pressure applied to the surface by the roller brush is incorrectly set.	Adjust according to operator's manual
	Side brush incorrectly set	
Material is ejected from under the sweeper	Brush rotational speed too high. Brush incorrectly set. Incorrect setting on the carrying vehicle	Check and adjust according to operator's manual





# NOTES

A series of horizontal dotted lines for writing notes.