



PRONAR Sp. z o.o.

17-210 NAREW, UL. MICKIEWICZA 101A, PODLASKIE PROVINCE, POLAND

PHONE: +48 085 681 63 29

+48 085 681 64 29

+48 085 681 63 81

+48 085 681 63 82

FAX: +48 085 681 63 83

+48 085 682 71 10

[www.pronar.pl](http://www.pronar.pl)

# OPERATOR MANUAL

## ROTARY RAKE

# PRONAR ZKP900D

TRANSLATION OF THE ORIGINAL COPY OF THE MANUAL

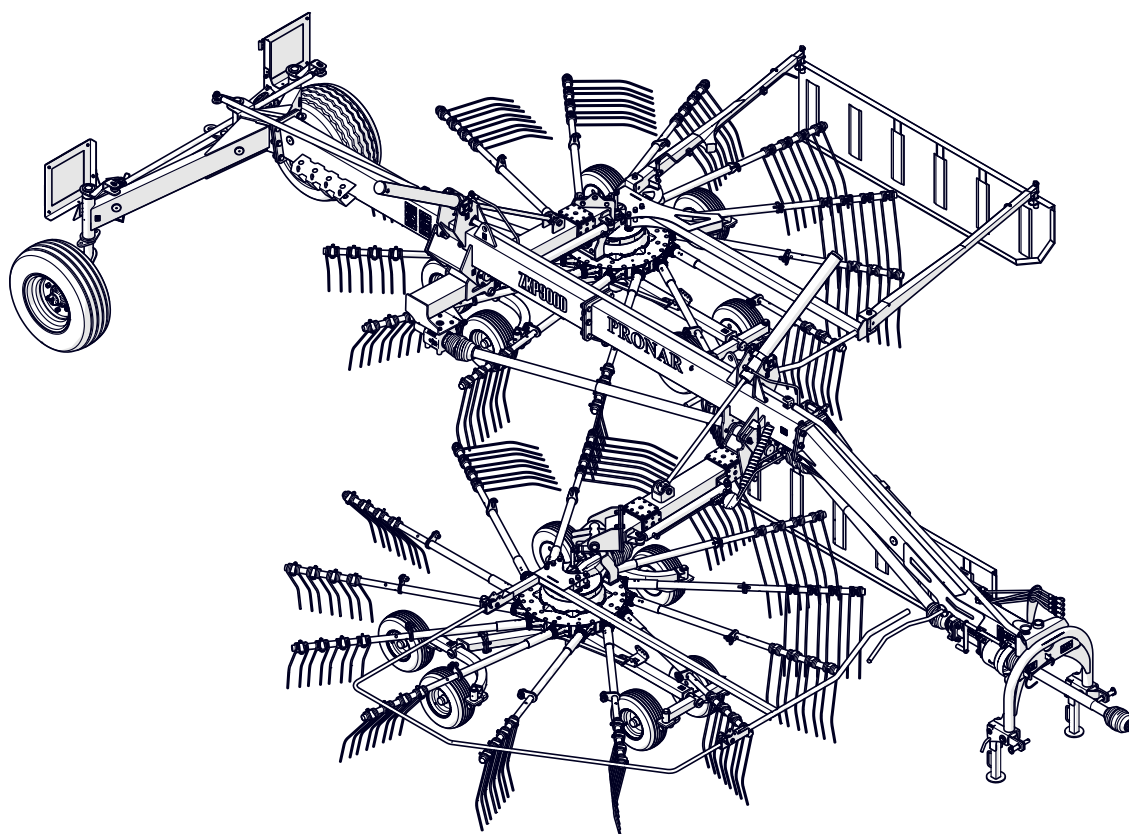

KEEP FOR FUTURE REFERENCE

EDITION: 1B

12-2021

PUBLICATION NO.: 578.01.UM.1B.PL





---

# INTRODUCTION

## INTRODUCTION

**Information in this document is current at date of publication.** As a result of improvements, some numerical values, illustrations and assemblies (standard, additional and optional equipment) referred to in this publication may not correspond to the actual specification of the machine delivered to the user.

The figures shown in this publication are intended to explain the principle of operation of the machine and may differ from the actual specification. The above cannot be a reason for any claims.

The manufacturer reserves the right to introduce design changes in machines produced that facilitate and improve the quality of machine operation, without making minor amendments to this

Operator Manual.

This Operator Manual is an integral part of the machine documentation. Before using the machine, the user must carefully read this Operator Manual and observe all recommendations. This guarantees safe operation and ensures failure-free work of the machine. The machine is designed to meet obligatory standards, documents and legal regulations currently in force.

If the information in this Operator Manual needs clarification, refer for assistance to the sale point where the machine was purchased or to the Manufacturer.

The serial numbers of the machine and major subassemblies should be inscribed in the spaces below after purchase of the machine.

Machine serial number

--	--	--	--	--	--	--

*This Operator Manual contains important safety and operating instructions for the machine. The Operator Manual should be kept near the machine so that it is accessible to authorized operators.*

*Keep this manual for future reference. If the Operator Manual is lost or damaged, contact the seller or the manufacturer for a copy.*

*The Operator Manual is intended for the end user. For this reason, some required maintenance activities are listed in the inspection tables but the procedure is not described in this Operator Manual.*

*To perform these steps, call the manufacturer's authorized service centre.*

## SYMBOLS APPEARING IN THIS OPERATOR MANUAL

### **DANGER**

Information, descriptions of danger and precautions as well as recommendations and prohibitions associated with the safety of use are marked in the text with the sign **DANGER**. Failure to observe the instructions may endanger the machine operator's or other person's health or life.

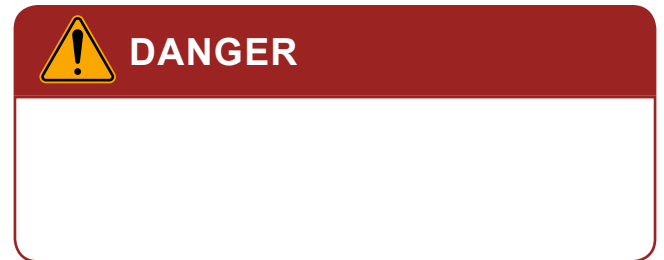

### **ATTENTION**

Vital information and instructions that must be observed are highlighted by a border and accompanied by the text: **IMPORTANT**. Failure to observe the instructions may lead to damage to the machine as a result of improper operation, adjustment or use.

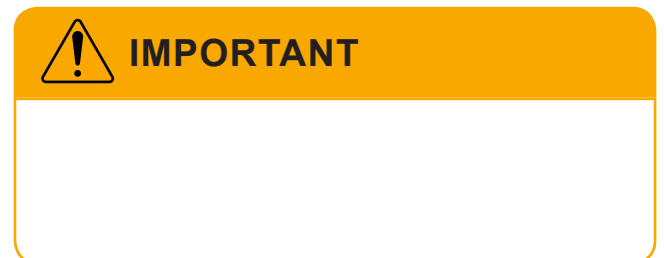

### **TIP**

Additional tips included in the Operator Manual describe useful advice for the machine operation and are marked with the sign **TIP**.



In order to focus the user's attention on the need to perform maintenance, the relevant section of the Operator Manual is marked with the clock pictogram.

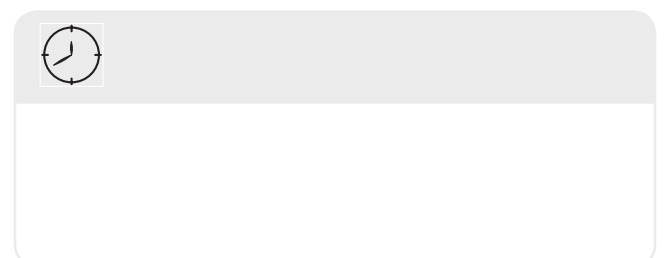

## DIRECTIONS USED IN THIS OPERATOR MANUAL

*Left side* – side to the left hand of the operator facing in the direction of machine's forward travel.

*Right side* – side to the right hand of the operator facing in the direction of machine's forward travel.

*Rotation to the right* – clockwise rotation of a mechanism (the operator is facing the mechanism).

*Rotation to the left* – counterclockwise rotation of a mechanism (the operator is facing the mechanism).

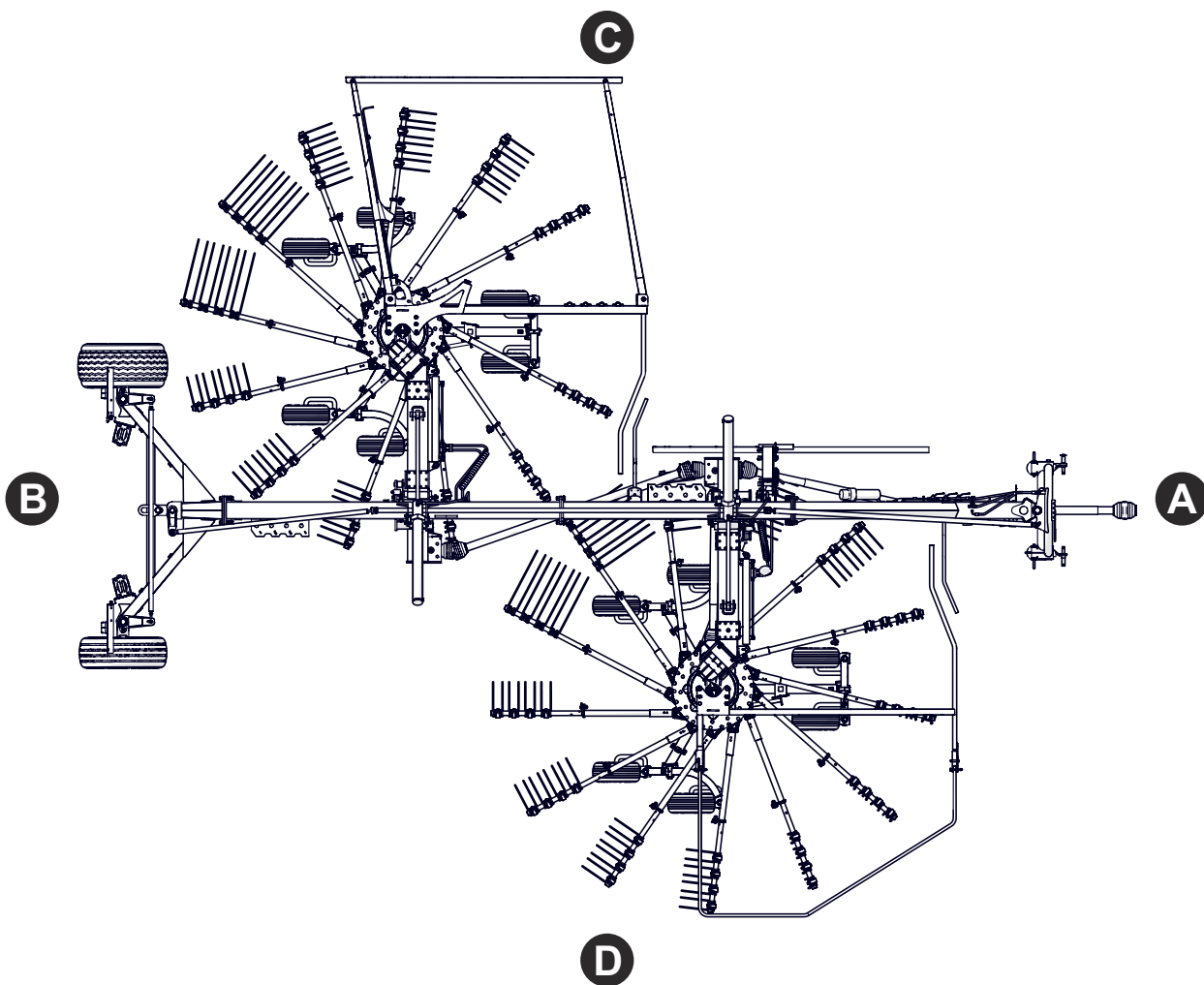

**Figure 1.1** Directions used with reference to the machine  
(A) front, - (B) rear, - (C) left side, - (D) right side

U.03.1.EN

## INSPECT THE MACHINE UPON DELIVERY

The manufacturer guarantees that the machine is fully operational and has been checked according to quality control procedures and is ready for use. This does not release the user from an obligation to check the machine's condition after delivery and before first use. Detailed information concerning the machine hand-over are included in the *WARRANTY BOOK*.

*Annex* to this manual includes INITIAL SET-UP INSTRUCTIONS describing the first installation steps after delivery.

Before hitching the machine to the tractor, confirm that it is suitable for this purpose (see *Requirements for carrier vehicle*).

### INSPECTION RECOMMENDATIONS

- Check completeness of the machine according to order (standard and optional equipment).
- Check the machine for missing parts or damage resulting from wrong transport of the machine to its destination (crushing, piercing, bending or breaking of parts etc.).
- Check technical condition of covers and protection devices.
- Check condition of paint coating; check the machine for traces of

### TIP

Releasing the machine to the buyer involves a detailed visual inspection and verification of the machine operation, as well as instructions for the buyer on the basic principles of operation. The trailer is operated for the first time in the presence of the Seller.

corrosion.

- Check technical condition of tyres and tyre pressure.
- Check if the nuts and bolts fixing the wheels are properly tightened.
- Check technical condition of suspension system and if correctly installed.
- Check technical condition of hydraulic lines.
- Check that there are no hydraulic oil leaks.
- Check technical condition of the rotary rake lights and indicators,
- Check technical condition of PTO shafts, their shields and securing chains.
- Check hydraulic cylinders for leaks of hydraulic oil.

Discovered defects should be notified directly to the seller in order to remove them.

## FIRST START-UP OF THE MACHINE



### IMPORTANT

During the first use, the machine is checked in the presence of the Seller. The Seller is obliged to conduct the training in safe and correct operation of the trailer.

Training by the seller does not release the user from the obligation to read this Operator Manual and the Operator Manual of PTO shaft attached to the machine and observe all recommendations.

Before you start using the machine, you should familiarize yourself with its design, principle of operation, available equipment and operation and, above all, with safety rules.

### PROCEDURE

- The user must read this *Operator Manual* and follow all instructions.
- Perform the daily inspection of the machine in accordance with the guidelines in the inspection schedule.
- Check all the machine lubrication points, lubricate if necessary according to the recommendations in the lubrication schedule.
- Check all nut and bolt connections (in particular raking arms, spring rake tines, wheels, protective shields).
- Check oil level in bevel gears.
- Check technical condition of PTO shafts, their shields and securing

chains.

- Check technical condition of hitching system pins and locking cotter pins.
- Ensure that hydraulic and electric connections in agricultural tractor are according to the requirements, if not the machine should not be hitched to the carrier vehicle.
- Make sure that the oil of the same kind and grade is used in the machine hydraulic system and the tractor hydraulic system or the oils used in the machine hydraulic system and the tractor hydraulic system are mixable.
- Make sure that the attached PTO shaft may be connected to the tractor (*PTO shaft should be suitable for the tractor – see the OPERATOR MANUAL OF PTO SHAFT*),

*Check the PTO shaft length in the most favourable and the most difficult working conditions, check whether the PTO shaft pipes are sufficiently covered when the widest angle is set between the tractor and the machine, check whether the PTO shaft can be still slid when the smallest angle is set (while turning), make sure that the*





## IMPORTANT

Pipe profiles of the PTO shaft must overlap at least at 1/2 of the length in normal working conditions and at least at 1/3 of the length in all working conditions. When adjusting the PTO shaft, follow the instructions presented in the Operator Manual of the PTO shaft.

When the tractor with the manure spreader are turning or travelling on an uneven terrain, the PTO shaft may be damaged and/or destroyed if it is squeezed or disconnected as a result of its wrong adjustment.

## TIP

Adjustment of the PTO shaft applies only to a specific type of tractor. If the machine is connected to a different type of tractor, the adjustment procedure for this type of tractor should be possibly carried out.

*tractor PTO rotation direction is correct.*

If all the above checks have been performed and there is no doubt as to the machine good technical condition, it can be connected to tractor (see section *HITCHING TO TRACTOR*).

Start tractor engine, check all systems and perform a test run of the machine without load before beginning work. It is recommended that the inspection is conducted by two people, one of which should always remain in the tractor cab. Test start should be conducted according to the sequence shown below.

- Hitch the machine to tractor.



## DANGER

Careless and incorrect use and operation of the machine, and failure to follow instructions in this Operator Manual is dangerous to your life and health. The machine must never be used by unauthorised persons, including children, and people under the influence of alcohol or other abusive substances. Non-compliance with the safety rules of this Operator's Manual can be dangerous to the health and life of the operator and others.

- Connect PTO shaft and secure it in a proper manner.
- Connect hydraulic system and electrical system lines.
- Check lights for correct operation.
- Set raking arms, raise raking assemblies upwards maximally using the crank, so that springtines do not touch surface.
- Start tractor.
- Check for correct operation of the hydraulic systems of the following assemblies: raking assembly lifting/lowering system, raking width adjusting system.

*Using the appropriate selective control valve lever in the tractor cab, start the hydraulic cylinders. Check whether lines are connected in a correct manner.*

- Start tractor PTO slowly (starting the drive of the raking assembly gears) and leave it for a few minutes.

*Check that there is no knocking or noise in the drive system and in the raking assembly gears arising from scraping or grinding of metal elements, Check proper rotation of raking system. Check proper action of cam mechanism of the raking assembly gear (spring tines should lower and raise according to current arm position),*

- Turn off the PTO drive, turn off the agricultural tractor engine, immobilize the tractor with the parking brake and unhitch the machine from the tractor.

The machine may be used only when all preparatory activities have been completed satisfactorily. If during test run worrying symptoms occur such as:

- excessive noise and abnormal sounds originating from the rubbing of moving elements,
- hydraulic oil leak,



### IMPORTANT

Before using the rotary rake always check its technical condition. In particular check the technical condition of the raking system, wheel system, all protective guards and correct condition of mounting of raking fingers.



### IMPORTANT

Check correctness of hydraulic connections. Replace conduit plugs possibly. Failure to follow instructions in this Operator Manual or starting the machine incorrectly may cause damage to the machine. The technical condition before starting the machine must be no cause for concern.

- incorrect hydraulic system operation
- other faults,

immediately cut off oil supply, turn off tractor PTO drive and do not operate the machine until the malfunction is corrected. If a fault cannot be rectified or the repair could void the warranty, please contact retailer for additional clarifications or to perform the repair.

U.12.4.EN



**PRONAR Sp. z o.o.**

ul. Mickiewicza 101 A

17-210 Narew, Polska

tel./fax (+48 85) 681 63 29, 681 63 81, 681 63 82,  
681 63 84, 681 64 29

fax (+48 85) 681 63 83

http://www.pronar.pl

e-mail: pronar@pronar.pl

## EC DECLARATION OF CONFORMITY OF THE MACHINERY

PRONAR Sp. z o.o. declares with full responsibility, that the machine:

Description and identification of the machinery	
Generic denomination and function:	<b>Rotary Rake</b>
Type:	<b>ZKP900D</b>
Model:	—
Serial number:	
Commercial name:	<b>Rotary Rake PRONAR ZKP900D</b>

to which this declaration relates, fulfills all the relevant provisions of the Directive **2006/42/EC** of The European Parliament and of The Council of 17 May 2006 on machinery, and amending Directive 95/16/EC (Official Journal of the EU, L 157/24 of 09.06.2006).

The person authorized to compile the technical file is the Head of Research and Development Department at PRONAR Sp. z o.o., 17-210 Narew, ul. Mickiewicza 101A, Poland.

This declaration relates exclusively to the machinery in the state in which it was placed on the market, and excludes components which are added and/or operations carried out subsequently by the final user.

Narew, the 2020-05-06

Place and date

Z-CIA DYREKTORA  
dla technicznych  
czynności

*[Signature]*

Full name of the empowered person  
position, signature

**PRONAR Spółka z o.o.**

17-210 Narew ul. Mickiewicza 101A

Tel. (85) 681 63 29, 682 72 54

Fax: (85) 681 63 83

NIP 543-02-00-939, KRS 0000139188

BDO 000014169



# Contents

## INTRODUCTION

INTRODUCTION	2
SYMBOLS APPEARING IN THIS OPERATOR MANUAL	3
DIRECTIONS USED IN THIS OPERATOR MANUAL	4
INSPECT THE MACHINE UPON DELIVERY	5
FIRST START-UP OF THE MACHINE	6

## BASIC INFORMATION

1.1	IDENTIFICATION	1.2
1.2	INTENDED USE	1.3
1.3	EQUIPMENT	1.5
1.4	TERMS & CONDITIONS OF WARRANTY	1.6
1.5	TRANSPORT	1.7
1.6	ENVIRONMENTAL RISK	1.10
1.7	WITHDRAWAL FROM USE	1.11

## SAFETY ADVICE

2.1	SAFE USE	2.2
2.2	SAFETY WHEN HITCHING THE MACHINE	2.3
2.3	SAFETY RULES WHEN MAINTAINING HYDRAULIC SYSTEM	2.4
2.4	SAFETY DURING TRANSPORT TRAVEL	2.5
2.5	SAFETY DURING MAINTENANCE WORK	2.6
2.6	SAFETY DURING MACHINE OPERATION	2.8
2.7	SAFE OPERATION OF THE PTO SHAFT	2.9
2.8	RESIDUAL RISK	2.11
2.9	INFORMATION AND WARNING DECALS	2.12

## DESIGN AND OPERATION

3.1	TECHNICAL SPECIFICATION	3.2
3.2	GENERAL DESIGN	3.4
3.3	SUSPENSION SYSTEM AND WHEELS	3.6
3.4	RAKING ASSEMBLY	3.7
3.5	DRIVE TRANSMISSION	3.9
3.6	HYDRAULIC SYSTEM	3.10
3.7	LIGHTING SYSTEM	3.12

## CORRECT USE

4.1	CONNECT THE MACHINE TO THE CARRIER VEHICLE	4.2
4.2	TRANSPORTING THE MACHINE	4.5
4.3	MACHINE OPERATION	4.10
4.4	UNHITCH THE MACHINE FROM THE CARRIER VEHICLE	4.15
4.5	PROPER USE AND MAINTENANCE OF TYRES	4.17
4.6	CLEAN THE MACHINE	4.18
4.7	STORAGE	4.20

## MAINTENANCE

5.1	BASIC INFORMATION	5.2
5.2	PERIODIC MAINTENANCE SCHEDULE	5.3
5.3	HALF AXLE MAINTENANCE	5.5
5.4	WHEEL MAINTENANCE	5.8

5.5	INSPECTION OF CONNECTION PLUGS AND SOCKETS _____	5.10
5.6	INSPECTION OF PROTECTIVE SHIELDS _____	5.11
5.7	OPERATE TRANSMISSION _____	5.12
5.8	CHECK AND REPLACE SPRINGTINES _____	5.14
5.9	MAINTENANCE OF ELECTRICAL SYSTEM AND WARNING ELEMENTS _____	5.15
5.10	HYDRAULIC SYSTEM MAINTENANCE _____	5.16
5.11	REPLACE HYDRAULIC LINES _____	5.18
5.12	LUBRICATION _____	5.19
5.13	TIGHTENING BOLT CONNECTIONS _____	5.24
5.14	TROUBLESHOOTING _____	5.25

## FIRST ASSEMBLY MANUAL

PREPARATION _____	A.2
TURNING THE WHEELS _____	A.3
INSTALLING THE WARNING BOARDS _____	A.4
INSTALLING THE RAKING ASSEMBLIES _____	A.5







# SECTION 1

---

## BASIC INFORMATION

## 1.1 IDENTIFICATION

The rotary rake is marked with a nameplate (1), placed on right side of machine's lifting arm. When buying the rotary rotary rake check that the serial numbers on the machine agree with the number written in the *Warranty Book*, in the sales documents and in the *Operator Manual*.

The meaning of individual items of the nameplate – figure (1.1) are presented in the table below:

- A - machine name,
- B - machine type/symbol
- C - year of manufacture,
- D - gross weight [kg],
- E - serial number,
- F - Quality Control stamp,
- G - axle load [kg],
- H - hitch load [kg].

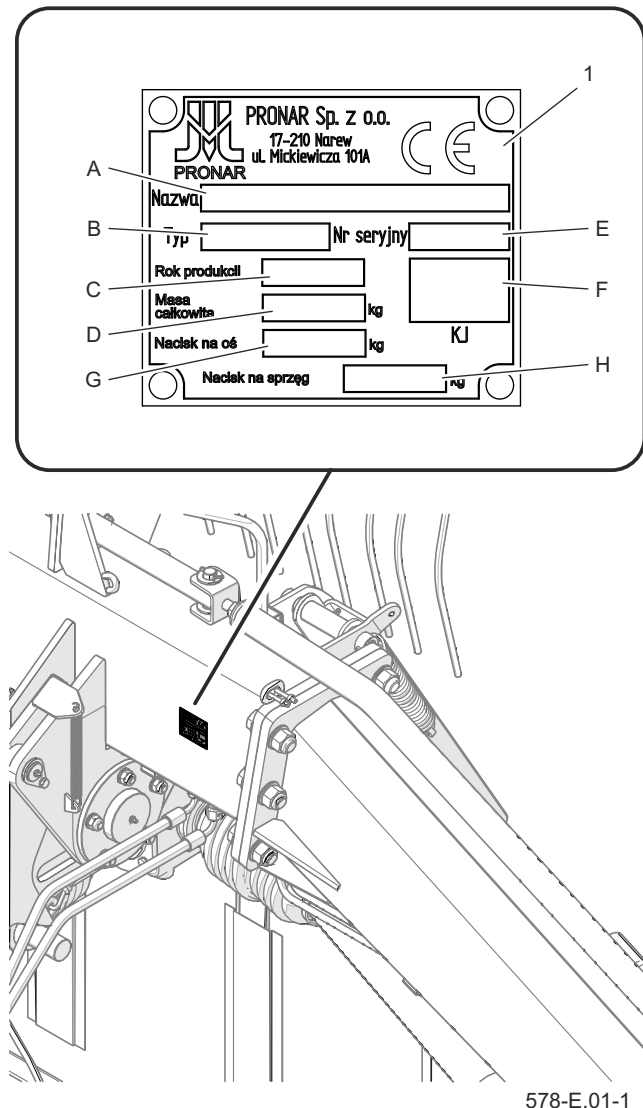

**Figure 1.1** Location of the nameplate.

E.1.7.578.01.1.EN

## 1.2 INTENDED USE

Rotary rake is designed for agricultural work: raking cut swaths (straw, grass, hays) and gathering it into windrows on stone free grassland with a level surface. Do NOT use the machine for any other purpose.

Transporting people, animals or other materials is prohibited and regarded as contrary to the intended purpose. During the use of the machine comply with all road traffic regulations and transport regulations in force in the given country, and any breach of these regulations is regarded by the Manufacturer as use contrary to the intended use of the machine.

Using it as intended also involves all actions connected with the safe and proper operation and maintenance of the machine.

Due to the above, the user is obliged to:

- carefully read this *OPERATOR MANUAL, WARRANTY BOOK, PTO SHAFT OPERATOR MANUAL* and observe the instructions contained in these documents,
- understand the machine's operating principle and how to operate it safely and correctly,
- adhere to the established maintenance and adjustment plans,
- comply with general safety regulations



### IMPORTANT

The machine must not be used for purposes other than those for which it is intended, in particular for:

- transporting people, animals
- for transporting whatever materials or objects.

while working,

- prevent accidents,
- comply with the road traffic regulations and transport regulations in force in the given country, in which the machine is used,
- carefully read the *Operator Manual* and comply with its recommendations,
- only hitch the machine to an agricultural tractor which meets all the Manufacturer's requirements.

The machine may only be used by persons, who:

- are familiar with the contents of this publication and with the contents of the agricultural tractor Operator Manual,
- have been trained in the machine operation and work safety,
- have the required authorisation to drive the vehicle and are familiar with the road traffic regulations and transport regulations.

**Table 1.1.** Requirements for carrier vehicle (agricultural tractor).

Contents	Unit	Requirements
<b>Rear three-point linkage</b> Category	-	I & II according to ISO 730-1
<b>Rear power take-off shaft (PTO)</b> Type	-	type 1 according to ISO 500 (Nominal diameter 35 mm, 6 splines)
Max engine RPM	rpm	540
<b>Hydraulic system</b> Hydraulic oil	-	AGROL U <sup>(1)</sup>
System pressure rating	bar / MPa	160 / 16
Hydraulic sockets	-	One double acting section + one double acting section with floating position
<b>Electrical system</b> Electrical system voltage	V	12
Connection socket	-	7-pole, ISO 1724
<b>Other requirements</b> Minimum carrying vehicle power demand	kW / KM	59 / 80

<sup>(1)</sup> – use of other oil is permitted, on condition that it may be mixed with the existing oil.

Detailed information can be found on the product information card.

E.1.7.578.02.2.EN

## 1.3 EQUIPMENT

**Table 1.2.** Machine equipment

Equipment	Standard	Additional	Optional
Operator Manual	•		
Warranty Book	•		
Lighting system connection cable	•		
Wheel chocks	•		
Wide-angle shaft for connecting the rotary rake with tractor	•		
Reflective warning triangle		•	
Document holder		•	
Raking springtines safeguards		•	
Wide tread tyres 340/55-16			•

### TIP

Recommended wide-angle shaft for connecting the rotary rake with tractor: 7G4R081CEWR7007A B&P

E.1.7.578.03.1.EN

## 1.4 TERMS & CONDITIONS OF WARRANTY

### TIP

Demand that the seller carefully and accurately fills out the **Warranty Book** and warranty repair coupons. A missing date of purchase or sale point stamp may make the user ineligible for any warranty repair or refund.

PRONAR Sp. z o.o. Narew guarantees the reliable operation of the machine when it is used according to its intended purpose as described in the *Operator Manual*. Defects discovered during the warranty period will be removed by the Warranty Service. The repair period is specified in the *Warranty Book*.

The warranty does not cover those parts and sub-assemblies of the machine which are subject to wear in normal usage conditions, regardless of the warranty period. The warranty service only applies to such cases as: mechanical damage which is not the user's fault, factory defects of parts, etc.

In the event of damage arising from:

- mechanical damage which is the user's fault, damage caused by road accidents,

- incorrect use, adjustment or maintenance, use of the machine for purposes other than those for which it is intended,
- use of damaged machine,
- repairs carried out by unauthorised persons, repairs carried out improperly,
- making unauthorised alterations to machine design,

the user will lose the right to warranty service.

The user is obliged to immediately report all noticed damage, regardless of whether the damage is covered by the warranty or not. For detailed Terms & Conditions of Warranty, please refer to the *Warranty Book* attached to each newly purchased machine.

Do NOT attempt to modify the machine without the written consent of the Manufacturer. In particular, do NOT weld, drill holes in, cut or heat the main structural elements of the machine, which have a direct impact on the machine operation safety.

E.1.7.578.04.1.EN

## 1.5 TRANSPORT

To save space, the rotary rake is partially disassembled for shipment. Before the first start-up, it should be assembled in accordance with appendix A "FIRST ASSEMBLY MANUAL" to prepare it for normal operation.

The machine is delivered to the user on a transport vehicle. Transport of the machine is permissible connected to a carrier vehicle provided the vehicle's driver familiarises himself with the machine's Operator Manual and particularly with information concerning safety and principles of hitching and transport on public roads.

When loading and unloading the machine, follow the general health and safety regulations for reloading work. Persons operating reloading equipment must have the qualifications required to operate these



### IMPORTANT

When transporting the machine independently, the user must carefully read this Operator Manual and observe all its instructions.

When being transported on a motor vehicle the machine must be secured on the vehicle's platform in accordance with the transport safety requirements. The driver of the vehicle should use extreme caution while driving. This is due to the vehicle's centre of gravity shifting upwards when the machine is loaded.



### DANGER

Incorrect use of securing measures may cause an accident.

Persons must NOT be present in the manoeuvring zone during transferring the machine to another means of transport.

machines. The machine should be attached to lifting equipment in places specially designed for this purpose (Figure 1.3). Securing point is marked with information decal.

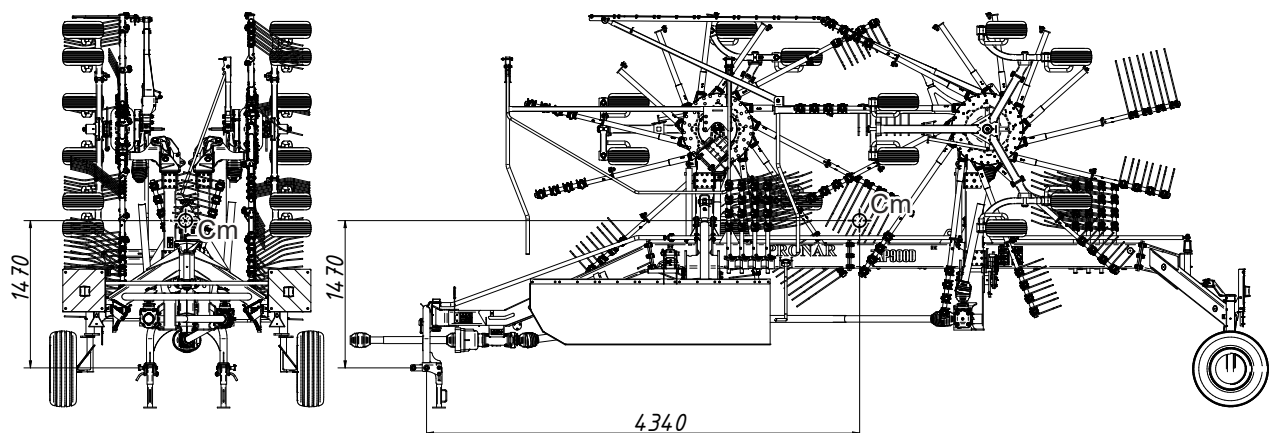

578-E.02-1

**Figure 1.2** Machine's centre of gravity

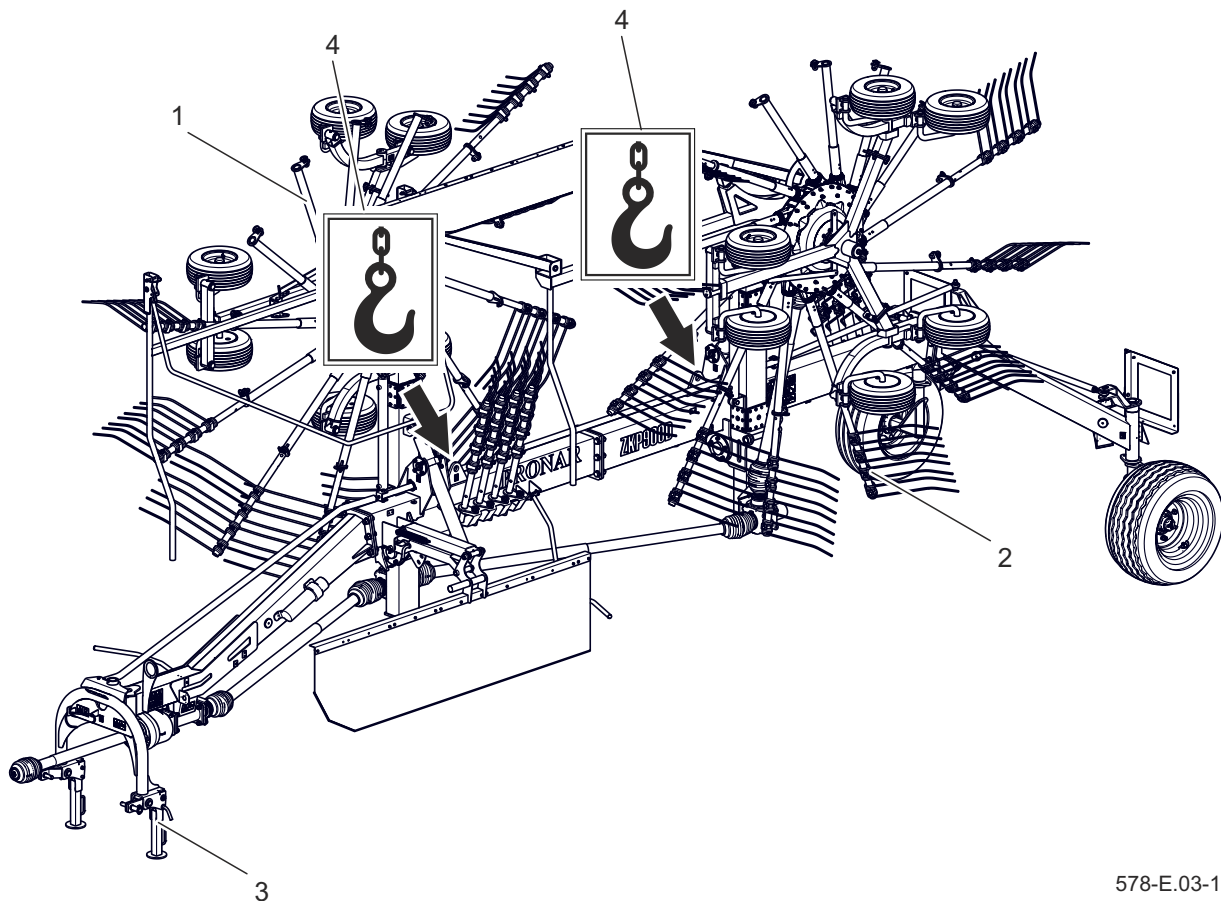

578-E.03-1

**Figure 1.3** Location of transport lugs

(1) right side raking assembly, (2) left side raking assembly, (3) parking stand (4) transport lugs

During reloading and transport, the rotary rake should be set in transport position, i.e. right side raking assembly (1) and left side raking assembly (2) must be raised, and parking stand (3) must be lowered - figure (1.3). It is recommended that during transport of the machine the raking arms are dismantled. In the event that cable or belt of transloading equipment may be caught by protruding rake elements placed in transport position, dismantle them. When lifting the machine take special care to avoid tipping over the machine and the

risk of injuries from protruding parts.



### IMPORTANT

Use only certified and technically reliable securing measures. Carefully read the information contained in the Operator Manuals for the given securing measures.

Do not attach slings and any kind of cargo fasteners to elements other than those intended for this purpose (do NOT attach to hydraulic system and electrical system components).

### TIP

During loading, rotary rake should be placed in transport position.



The machine should be firmly secured on the transport vehicle platform with belts or chains equipped with a tensioning mechanism. The fastening equipment used must have a valid safety certificate. Chocks or other objects without sharp edges should be placed under the wheels of the rotary rake to prevent it from rolling. The chocks must be fixed to the platform of the vehicle.

**IMPORTANT**

During transport, the PTO shafts should be protected against damage.

During reloading work, take special care not to damage any accessories or paint finish. The tare weight of the rotary rake in condition ready for travel is given in table (3.1).

E.1.7.578.05.1.EN

## 1.6 ENVIRONMENTAL RISK

A hydraulic oil leak constitutes a direct threat to the natural environment owing to its limited biodegradability. While carrying out maintenance and repair work, which involves the risk of an oil leak, this work should take place on an oil resistant floor or surface. In the event of oil leaking into the environment, first of all contain the source of the leak, and then collect the leaked oil using available means. Remaining oil should be collected using sorbents, or by mixing the oil with sand, sawdust or other absorbent materials. The oil contaminations, once gathered up, should be kept in a sealed, marked, hydrocarbon resistant container, and then passed on to the appropriate oil waste recycling centre. The container should be kept away from heat sources, flammable materials and food.



### DANGER

Used hydraulic oil or gathered remains mixed with absorbent material should be stored in a precisely marked container. Do not use food packaging for this purpose.



### IMPORTANT

Waste oil should only be taken to the appropriate facility dealing with the re-use of this type of waste. Do NOT dispose of or pour oil into sewerage drains or water reservoirs.

Oil which has been used up or is unsuitable for further use owing to loss of its properties should be stored in its original packaging in the conditions described above. Detailed information on hydraulic oils can be found in the Material Safety Data Sheets.

E.1.7.578.06.2.EN

## 1.7 WITHDRAWAL FROM USE

Should you decide to withdraw the machine from use, comply with the regulations in force in the given country regarding withdrawal from use and recycling of machines withdrawn from use.

Before proceeding to dismantle equipment, oil shall be completely removed from hydraulic system and transmission. Locations of drain plugs and method for draining oil are described in Section 5.

When spare parts are changed, worn out or damaged parts should be taken to



### DANGER

During dismantling, use the appropriate tools, equipment (overhead crane, crane or hoist etc.) and use personal protection equipment, i.e. protective clothing, footwear, gloves and eye protection etc. Avoid contact of skin with oil. Do not allow used hydraulic oil to spill.

a collection point for recyclable raw materials. Used oil and also rubber and plastic elements should be taken to the appropriate facilities dealing with the recycling of this type of waste.

E.1.7.578.07.1.EN



# SECTION 2

---

SAFETY ADVICE

## 2.1 SAFE USE

- Before using the machine, carefully read this Operator Manual, the Operator Manual of the PTO shaft and *Terms & Conditions of Warranty*. When operating the machine, follow all instructions in these documents.
- The machine may only be used by persons qualified to drive carrier vehicles (tractors) and trained in machine operation. Rotary rake can be operated by a single person only.
- Careless and improper use and operation of the machine, and failure to comply with the instructions of this Operator Manual is dangerous to your health as well as health of bystanders.
- Be aware of the residual risk. Use caution when operating this machine and follow all relevant safety instructions.
- The machine must never be used by persons, who are not authorised to drive carrier vehicles (agricultural tractors), including children and people under the influence of alcohol or other drugs.
- The machine must not be used for purposes other than those for which



### IMPORTANT

If the information in this Operator Manual is difficult to understand, contact the seller who runs the authorised technical service on behalf of the Manufacturer, or contact the Manufacturer directly.

- it is intended. Anyone who uses the machine for purposes other than those for which it is intended takes full responsibility for any consequences of this potentially incorrect use. Use of the machine for purposes other than those for which it is intended by the Manufacturer may invalidate the guarantee.
- The machine may only be used when all the protective features (i.e. safety guards, bolts, cotter pins, warning decals) are technically sound and correctly positioned. In the event of loss or damage to the protective features, they must be replaced with new ones.
  - Do NOT use an inoperative machine.
  - Any modification of the machine releases the manufacturer from any responsibility for damage or detriment to health which may arise as a result.

## 2.2 SAFETY WHEN HITCHING THE MACHINE

- The machine should be hitched to and transported with only such a carrier vehicle (tractor) which meets the Manufacturer's requirements (minimum tractor power demand, required three-point linkage category, etc.) – see table *REQUIREMENTS FOR AGRICULTURAL TRACTOR*.
- Before hitching the machine to the tractor, check the technical condition of the hitching system of the rotary rake and the tractor.
- Do NOT hitch the machine to carrier vehicle (agricultural tractor) if hydraulic oil in the two machines is of different types.
- Use only genuine pins and safeguards to hitch the machine to the carrier vehicle.
- The carrier vehicle (agricultural tractor) to which the machine will be coupled must be technically reliable and must meet all manufacturer's requirements.
- Be especially careful when hitching and unhitching the machine.
- When hitching, there must be nobody between the machine and the carrier vehicle.
- After completion of hitching the machine, check the safeguards.
- Before using the rotary rake always check its technical condition, especially in terms of safety. In particular check the technical condition of the suspension system, wheels, hydraulic system connections and correct mounting of rakes and protective shields.
- Hitching and unhitching may only take place when the machine and tractor (carrier vehicle) are turned off.
- Machine unhitched from the carrier vehicle must be placed on level, sufficiently hard surface in such a manner as to ensure that it is possible to connect it again.
- Rotary rake uncoupled from tractor must be supported by supports and secured against rolling away by using wheel chocks or other elements without sharp edges.
- The machine disconnected from the carrying vehicle must be secured against unauthorized use by means of safety devices.

F.1.7.578.02.1.EN

## 2.3 SAFETY RULES WHEN MAINTAINING HYDRAULIC SYSTEM

- The hydraulic system is under high pressure when operating.
- Use the hydraulic oil recommended by the Manufacturer. Never mix two types of oil.
- Regularly check the technical condition of the hydraulic lines and connections. There must be no oil leaks.
- In the event of the hydraulic system malfunction, discontinue using the machine until the malfunction is corrected.
- When connecting hydraulic lines to carrier vehicle, make sure that the hydraulic system is not under pressure. If necessary, reduce residual pressure in the system.
- In the event of injuries being caused by pressurised hydraulic oil, contact a doctor immediately. Hydraulic oil may find its way under the skin and cause infections. In the event of contact of oil with eye, rinse with large quantity of water and in the event of the occurrence of irritation consult a doctor. In the event of contact of oil with skin wash the area of contact with water and soap. Do NOT apply organic solvents (petrol, kerosene).
- Do not store hydraulic oil in packaging designed for storing food or foodstuffs.
- Rubber hydraulic lines must be replaced every 4 years regardless of their technical condition.
- Repair and replacement of hydraulic system elements should be entrusted to the appropriately qualified persons.

F.1.7.578.03.1.EN



## 2.4 SAFETY DURING TRANSPORT TRAVEL

Before driving on the roads:

1. Make sure that the machine is correctly hitched to the carrier vehicle (tractor) and check whether lights work correctly.
2. Fold the rotary rake to transport position and raise it to an appropriate height using rear suspension system.  
*In order to prevent inadvertent activation of the hydraulic system, the cut-off valves must be closed while moving the machine during its transport.*
3. Secure moving parts of the machine so as to eliminate any dangers posed by these parts while the machine is in motion.
4. Place slow-moving vehicle warning triangle plate in the bracket at the rear of the machine.

Also:

- When driving on public roads, observe all road traffic regulations in force in the country, in which the machine is used.
- Do not exceed the maximum speed



### DANGER

During transport, always disconnect the shaft from the tractor. Disconnected PTO shaft should be placed in the specifically prepared holder.

resulting from road conditions and design restrictions (max.25km/h). Adjust speed to the prevailing road conditions and other limitations arising from road traffic regulations.

- Do NOT ride on the machine or transport any materials on it.
- Do NOT leave tractor driver's seat when the tractor is moving.
- While driving on public roads the rotary rake must be fitted with a certified or authorised reflective warning triangle.
- Reckless driving and excessive speed may cause accidents.
- When driving the machine on uneven terrain, exercise particular caution and reduce the travel speed as the carrier and the machine may become damaged or overturned.

F.1.7.578.04.1.EN

## 2.5 SAFETY DURING MAINTENANCE WORK

- During the warranty period, any repairs may only be carried out by warranty service authorised by the Manufacturer. It is recommended that necessary repairs to machine should be undertaken by specialised workshops.
- In the event of any fault or damage, do not use the machine until the fault has been corrected.
- During work, use appropriate, close-fitting protective clothing, gloves and appropriate tools. When working on hydraulic systems it is recommended to use oil resistant gloves and protective goggles.
- Any modification of the machine releases the manufacturer from any responsibility for damage or detriment to health which may arise as a result.
- Before commencing any work on the machine, turn off the carrier vehicle (agricultural tractor) engine and wait until all rotating parts have come to a stop.
- Regularly check the technical condition of the safety devices and correct tightening of bolt connections.
- Regularly perform service inspections of machine as recommended by the Manufacturer.
- Do NOT perform maintenance or repair work under raised and unsupported machine.
- Before beginning repairs on hydraulic systems, reduce oil pressure.
- Servicing and repair work should be carried out in line with the general principles of workplace health and safety. In the event of injury, the wound must be immediately cleaned and disinfected. In the event of more serious injuries, seek a doctor's advice.
- Repair, maintenance and cleaning work should be carried out with the carrier vehicle (agricultural tractor) engine turned off and the ignition key removed. Immobilise the carrier vehicle (agricultural tractor) with parking brake. Ensure that unauthorised persons do not have access to the carrier vehicle (agricultural tractor) cab.
- Should it be necessary to change individual parts, use only original parts. Non-adherence to these requirements may put the user and other people's health and life at risk, and also damage the machine and invalidate the warranty.

- Before welding or electrical work, the machine should be disconnected from the power supply.
  - The paint coating should be cleaned off before beginning welding work. Burning paint fumes are poisonous for people and animals. Welding work should be carried out in a well lit and well ventilated space.
  - During welding work, pay attention to flammable or fusible elements (parts of the electric and hydraulic systems, plastic parts). If there is a risk that they will catch fire or be damaged, they should be removed or covered with non-flammable material before commencing welding work. Before beginning work, get ready a CO<sub>2</sub> or foam extinguisher.
  - Regularly check technical condition and mounting of all guards and protective elements.
  - In the event of work requiring the machine to be raised, use properly certified hydraulic or mechanical lifts for this purpose. After lifting the machine, stable and durable supports must also be used.
  - The machine must not be supported using fragile elements (bricks or concrete blocks).
  - After completing work associated with lubrication, remove excess oil or grease.
  - Perform daily visual inspection and functional checks to detect defects in the early stages or prevent accidents.
  - In order to reduce the danger of fire the machine must be kept in a clean condition.
- Observe the rules contained in chapter "Cleaning the machine".

F.1.7.578.05.1.EN

## 2.6 SAFETY DURING MACHINE OPERATION

- Before starting the machine make sure that there are no bystanders (especially children) or animals in the danger zone.  
Stop the machine when bystanders are in the affected danger zone.
- The machine operator is obliged to ensure proper visibility of the machine and the working area.
- Do not enter the machine rotation and folding zone.
- Each time the machine is used, always ensure that all the safety guards are in good condition and in place. Damaged or incomplete sub-assemblies must be exchanged for original new ones.
- Before starting work, always check condition and correct attachment of springtines on raking arms.
- During windrowing use the correct working position.
- While windrowing apply working speed recommendations.
- Before raising and lowering the machine's raking assemblies, make sure there are no bystanders nearby.
- Before starting the tractor with the connected machine make sure the PTO drive is not engaged, otherwise it can lead to uncontrolled operation of the machine.
- During machine operation do not occupy a different position than that of the operator in the tractor cab. Do NOT leave the cab, when the machine is in operation.
- Do NOT approach the machine until the rotating parts come to a complete stop.

F.1.7.578.06.1.EN

## 2.7 SAFE OPERATION OF THE PTO SHAFT

- The machine may only be connected to the carrier vehicle (tractor) by means of an appropriately selected PTO shaft recommended by the Manufacturer.
- Before using the machine, carefully read the PTO shaft Operator Manual and follow all instructions.
- Adjust the length of PTO shaft to compatible carrier vehicle (tractor) according to the Operator Manual of PTO shaft.
- The PTO shaft has markings on the casing, indicating which end of the shaft shall be connected to the carrier vehicle (tractor).
- Never use a damaged PTO shaft, it may cause an accident. A damaged shaft must be repaired or replaced.
- Disconnect the shaft drive each time when it is not necessary to drive the machine, or when the carrier vehicle (tractor) and the machine are positioned at an unsuitable angle with regard to each other.
- During transport the shaft must be stored in the horizontal position to avoid damage to safety guards or other protection elements.
- Disconnected PTO shaft should be



### DANGER

Before connecting or disconnecting the shaft, you must:

- disengage PTO drive
- switch off the engine of the implement carrier (tractor),
- engage parking brake,
- remove key from ignition.

placed in the specifically prepared holder.

- Before starting PTO, make certain that the PTO rotation direction and rotation speed are compliant with allowable rotation speed and rotation direction specified for the machine.
- When using the PTO shaft and the rotary rake, do not exceed the allowable rotation speed of the PTO shaft. Do NOT overload shaft and rotary rake and also engage the clutch suddenly.
- The chains preventing the shaft cover from turning while the shaft is working, shall be secured to a fixed element of machine structure.
- Do NOT use the securing chains to support the shaft while machine is parked or when transporting the machine.
- The drive shaft must be equipped with a cover. Do NOT use the shaft

- with damaged or missing guards.
- After connecting the shaft, ensure that it is correctly and safely connected to the carrier vehicle (tractor) and to the machine.
  - Before connecting PTO shaft, make certain that the PTO rotation direction is correct.
  - Do NOT wear loose clothing, straps or whatever that may become wrapped round the rotating drive shaft. Contact with rotating PTO shaft may cause severe injuries.
  - Do NOT go over and under the shaft or stand on it equally during work as also when the machine is parked.

F.1.7.578.07.1.EN

## 2.8 RESIDUAL RISK

Pronar Sp. z o. o. in Narew has made every effort to eliminate the risk of accidents. There is, however, a certain residual risk, which could lead to an accident, and this is connected mainly with the actions described below:

- using the machine for purposes other than those for which it is intended,
- being between the carrier vehicle (agricultural tractor) and the machine while the engine is running and when the machine is being attached,
- being on the machine while the engine is running,
- operating the machine with removed or faulty safety guards,
- workaround or disable guards from action,
- failure to maintain a safe distance from the danger zone or being within the zones while the machine is operating,
- use of the machine by persons who are not authorised and not able to operate it, in particular children and persons under the influence of alcohol, drugs or other abusive substances, etc.
- cleaning, maintenance and technical

checks when carrier vehicle (agricultural tractor) is connected and engine is running.

- making modifications to the machine without the consent of the Manufacturer,
- using unreliable PTO shaft.

The residual risk may be kept to a minimum by following the recommendations below:



- operate the machine in prudent and unhurried manner,
- sensibly apply the remarks and recommendations contained in the Operator Manual,
- carry out repairs and maintenance work in line with operating safety rules,
- repair and maintenance work should be carried out by persons trained to do so,
- use close fitting protective clothing,
- ensure unauthorised persons have no access to the machine, especially children,
- maintain a safe distance from prohibited or dangerous places
- do not climb on the machine when it is operating or transported

## 2.9 INFORMATION AND WARNING DECALS





The machine is labelled with the information and warning decals mentioned in Table 2.1. Throughout the machine use, you must ensure that any warning messages and information decals located on the machine are clear and legible. If any are destroyed or damaged, they must be replaced with new. New assemblies,

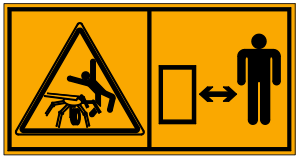

changed during repair, must be labelled once again with the appropriate safety signs. During machine cleaning do not use solvents, which may damage the coating of information decals and do not subject them to strong water jets.

**Table 2.1.** Information and warning decals

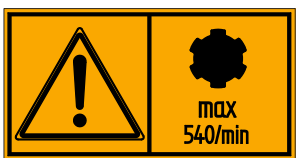
Item	Decal	Meaning
1		<p>Note Before starting work, carefully read the Operator Manual. <b>178N-0000001</b></p>
2		<p>Danger of inadvertent starting or rolling of the machine. Before beginning servicing or repair work, turn off the tractor engine and remove the key from the ignition. <b>178N-0000002</b></p>
3		<p>Do not reach into crushing space because elements may move. Danger of crushing hands or fingers. <b>178N-0000005</b></p>

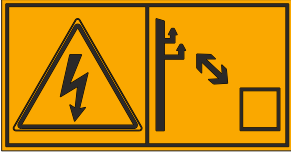
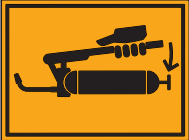

Item	Decal	Meaning
4		<p>Thrown out objects endanger the whole body. Keep a safe distance. <b>178N-0000006</b></p>
5		<p>Danger of being struck by rotating elements of the machine. Keep a safe distance from raking assembly. <b>178N-0000007</b></p>
6		<p>Transport lug points marking. <b>178N-0000009</b></p>
7		<p>Note Danger associated with the rotating PTO shaft. <b>185N-0000003</b></p>
8		<p>Note Maximum allowable PTO shaft rotation speed is 540 rpm. <b>185N-0000004</b></p>
9		<p>Risk of injury when machine is being arranged in transport or working position. <b>185N-0000007</b></p>
10		<p>Do not stand directly behind the tractor while operating the rear hitch. <b>185N-0000008</b></p>

Item	Decal	Meaning
11		<p>Keep a safe distance from electric power lines.</p> <p><b>185N-0000009</b></p>
12		<p>Grease the machine according to the lubrication schedule in the Operator Manual.</p> <p><b>185N-0000011</b></p>
13		<p>Machine model ZKP900D.</p> <p><b>578N-0000001</b></p>
14		<p>Manufacturer</p> <p><b>578N-0000003</b></p>

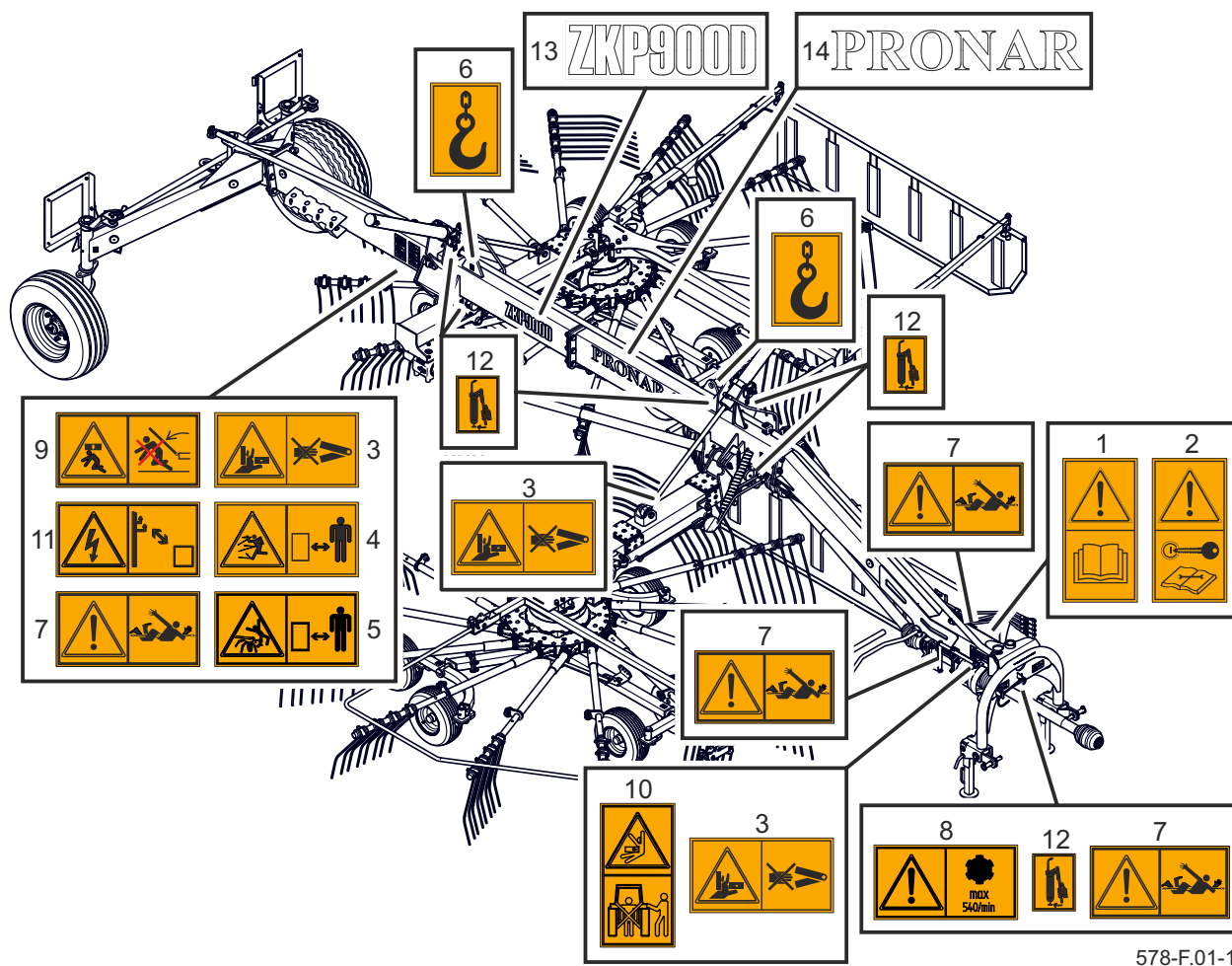

Figure 2.1 Locations of information and warning decals.

F.1.7.578.09.1.EN



# SECTION 3

---

DESIGN AND OPERATION

## 3.1 TECHNICAL SPECIFICATION

**Table 3.1.** Standard equipment specification

Contents	Unit	ZKP900D
<b>Dimensions in the transport position</b>		
Total length	mm	8,600
Width	mm	2,800
Height		
rakes extended	mm	3,950
rakes withdrawn	mm	4,650
<b>Dimensions in the operating position</b>		
Total length	mm	8,600
Width		
minimum	mm	7,150
maximum	mm	9,050
Height	mm	2350
<b>Technical specification</b>		
Number of swaths	pc.	1 or 2
Working width	mm	7,100 – 9,000
Distance between rotors	mm	600 – 1,900
Number of rotors	pc.	2
Number of rotor working arms	pc.	13
Number of raking spring tines on a single working arm	pc.	4
Linkage	-	cat. I & II according to ISO 730-1
Drawbar wheels and suspension	-	two steerable turning wheels
Raking assembly wheels and suspension	-	six steering wheels in tandem configuration
Type of rotor transmissions	-	dry (lubricated with grease)
Overload protection WPT	-	Backstop and overload clutch 900Nm
Minimum power demand	KM / kW	80 / 59
Maximum PTO speed	RPM	540
Tare weight	kg	2,820
Axle load	kg	1505

<b>Contents</b>	<b>Unit</b>	<b>ZKP900D</b>
Hitch load	kg	1315
Recommended working speed	km / h	10
Noise emission level	dB(A)	below 70
<b>Wheel axle tyres</b>		
1. Tyre	-	340/55-16
Air pressure in the tyres	kPa	160
Load index (min.)	-	133
Speed index (min.)	-	A8
2. Tyre	-	10.0/75-15,3
Air pressure in the tyres	kPa	400
Load index (min.)	-	122
Speed index (min.)	-	A8
3. Tyre	-	400/60-15,5
Air pressure in the tyres	kPa	490
Load index (min.)	-	145
Speed index (min.)	-	A8
<b>Raking assembly tyres</b>		
Tyre	-	16 x 6.5 – 8 (6PR)
Air pressure in the tyres	kPa	160
<b>Other information</b>		
Electrical system voltage	V	12
Adjustment of raking width	-	hydraulic
Raising the rotors to transport position	-	hydraulic - synchronized

G.1.7.578.01.1.EN

## 3.2 GENERAL DESIGN

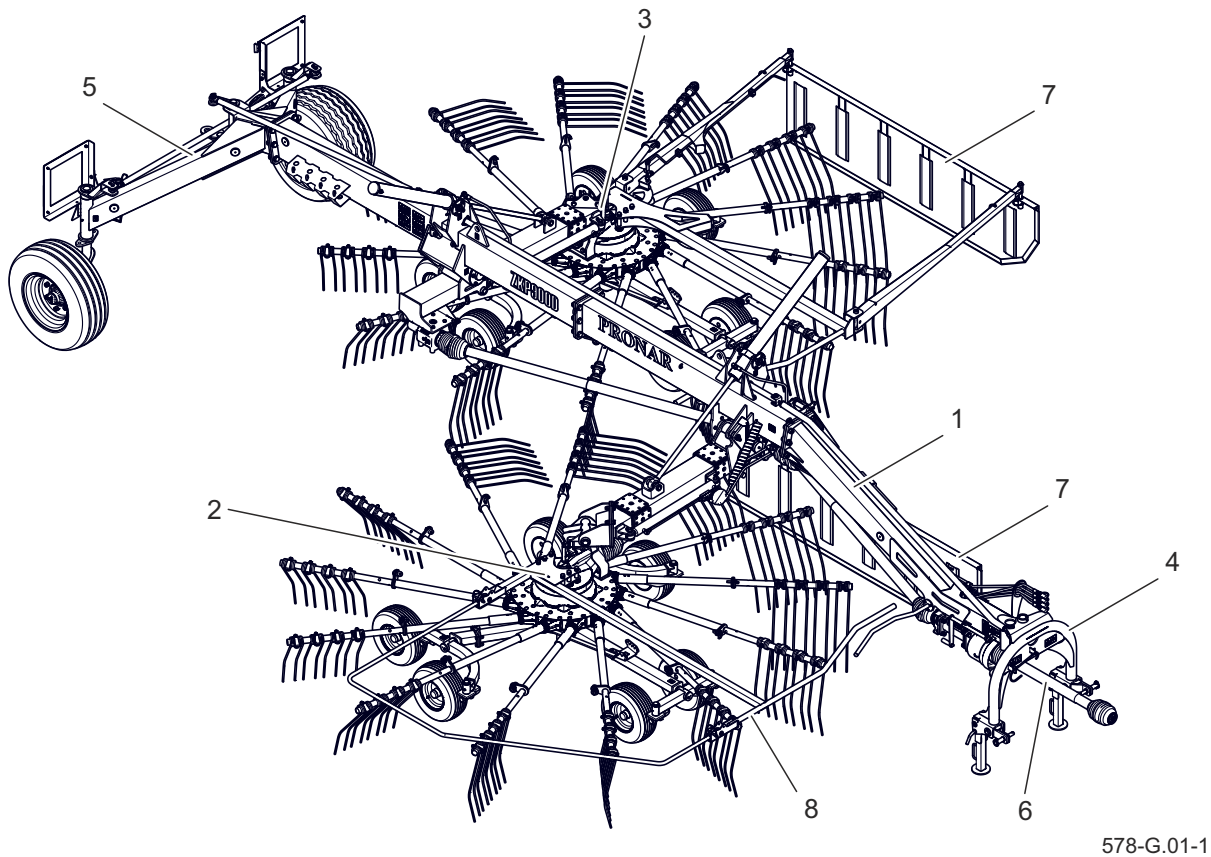

578-G.01-1

**Figure 3.1** ZKP900D rotary rake design

- |                             |                           |                          |
|-----------------------------|---------------------------|--------------------------|
| (1) main frame              | (2) right raking assembly | (3) left raking assembly |
| (4) load bearing suspension | (5) axle system           | (6) drive system         |
| (7) forming shield          | (8) protection guard      |                          |

Rotary rake design is shown in figure (3.1). The machine's main sub-assembly is the main frame (1). In the front part of the frame there is a load bearing suspension (4) for connection to the tractor three point linkage. On both sides of the main frame there are beams with extendible arms and two raking assemblies installed: right side raking assembly (2) with protective shield (8) and left side raking assembly (3). The extension of the arms to adjust the working

width is carried out hydraulically.

Raking assembly gears are driven by transmission (6) which consists of bevel gears and PTO shafts. In the rear part of the rotary rake there is axle system (5), which consists of axle frame and half axle with wheels.

Forming shields (7) are attached to lower part of the main frame and to left raking assembly. During machine operation shields acts as a barrier for the raked swath, due



to which the swath is not scattered but formed into a regular windrow.

G.1.7.578.02.1.EN

### 3.3 SUSPENSION SYSTEM AND WHEELS

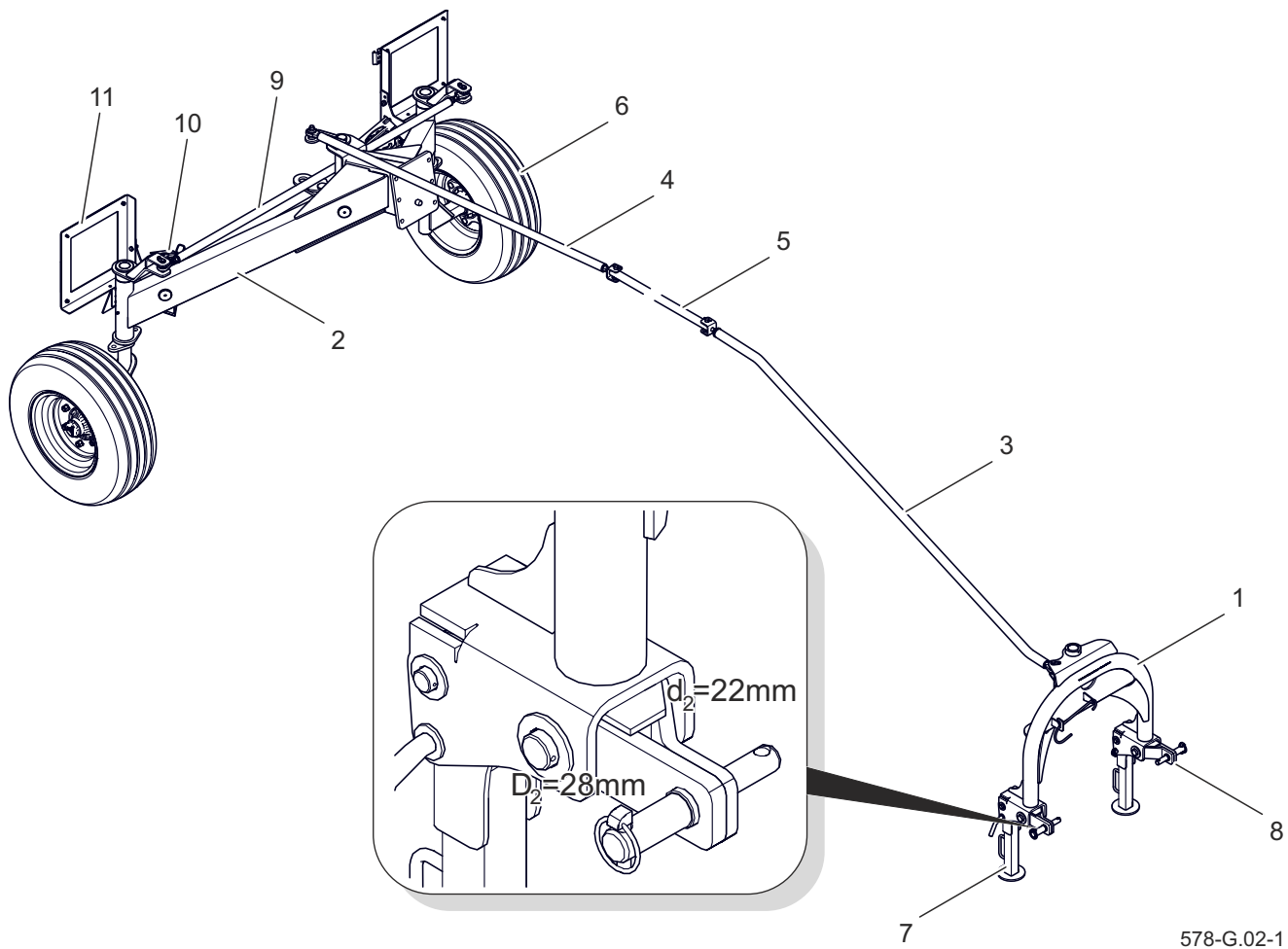

**Figure 3.2** Design of axle system and hitch system

- |                               |                          |                         |
|-------------------------------|--------------------------|-------------------------|
| (1) three point linkage frame | (2) axle frame           | (3) drawbar I           |
| (4) drawbar II                | (5) drawbar pipe         | (6) wheel               |
| (7) parking stand             | (8) hitch rocker arm     | (9) axle system drawbar |
| (10) wheel chock              | (11) rear lighting board |                         |

The main element of the linkage is the three point linkage frame (1), which is equipped with hitch rocker arms (8) with lower pins for connection to the tractor three point linkage.

The three point linkage frame is connected to axle system wheels (6) using tension rod and tube (3), (4), (9), (5). Such steering system enables the rotary rake to accurately follow the tractor track even at high driving speeds.

The three point linkage frame is connected

G.1.7.578.03.1.EN

### 3.4 RAKING ASSEMBLY

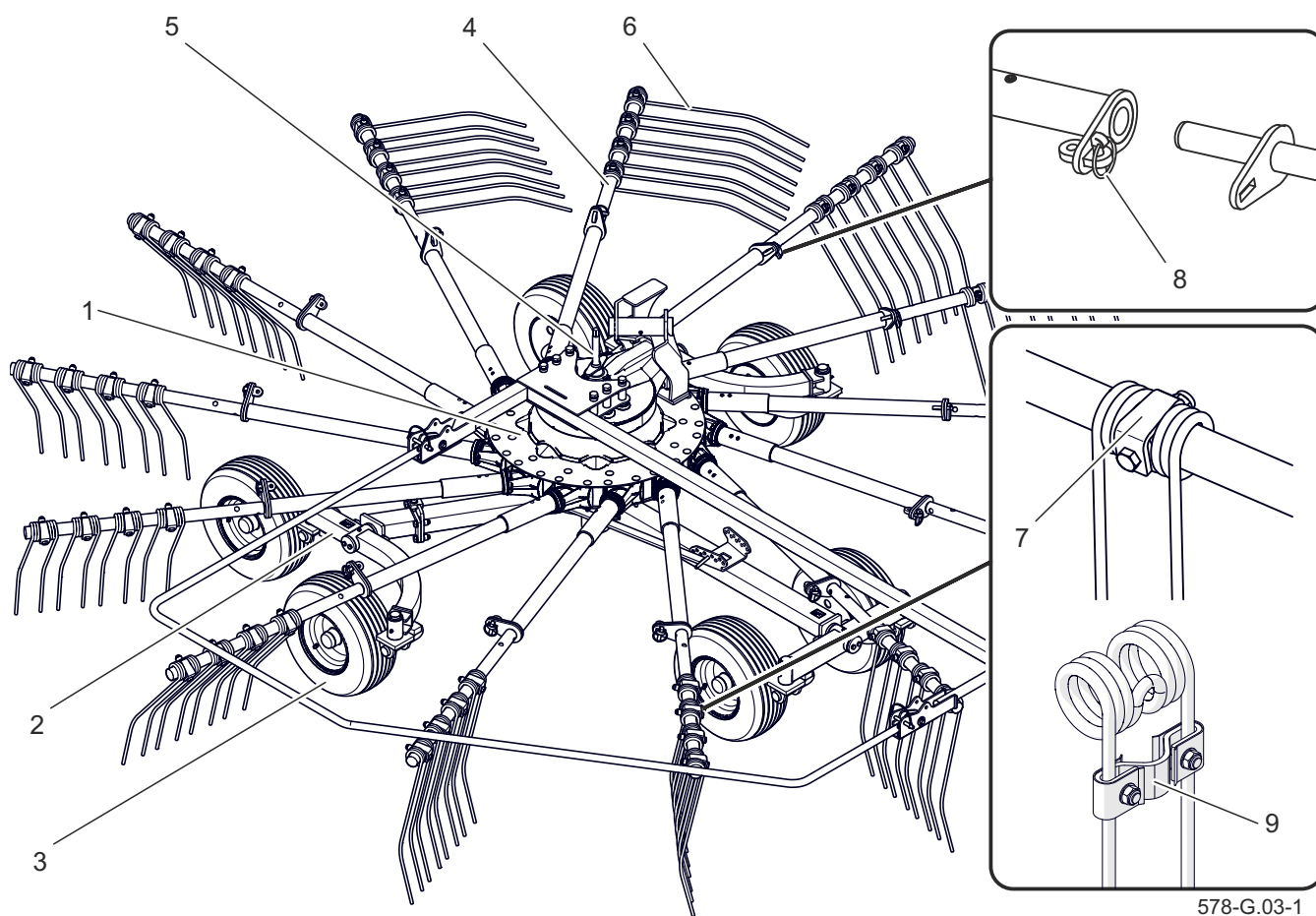

578-G.03-1

**Figure 3.3** Raking assembly design

- |                            |                    |                            |
|----------------------------|--------------------|----------------------------|
| (1) gear                   | (2) rocker arm     | (3) wheel                  |
| (4) raking arm             | (5) adjusting bolt | (6) spring tine            |
| (7) mounting angle section | (8) cotter pin     | (9) spring tine protection |

The transmission gearing (1) has 13 radiating shafts, to which raking arms (4) are secured. Each of the arms is equipped with 4 springtine fingers (6) for raking the swath. They are mounted on the arm extension with the aid of securing angles (7), which prevent tines from sliding or rotating. Depending on the rotation direction of the raking assembly, there are right and left raking arms. The raking arms are

fixed to the gearing transmission (1) and secured with the aid of cotter pins (8). In the lower part of the raking assembly there is axle system, which guarantees proper raking on wavy surface. Rocker arms (2) with wheels (3) are secured to the axle system frame. The height of raking arm setting above the surface is regulated by the adjustment screw (5) and secured by the interlock.

The gear (1) cam mechanism applied enables the rotation of individual arms, due to which the springtine fingers are lowered or raised according to current setting. During raking springtine fingers are lowered almost vertically. The raked swath is retained by the forming shield, due to which it is formed into an even windrow. In

remaining instances the raking springtines are raised to the upper position.

To prevent the loss of a broken springtine part, a springtine safeguard (9) (optional accessory), can be fitted to each springtine. Broken springtine in the swath may damage other agricultural machines operating in the field.

G.1.7.578.04.1.EN

### 3.5 DRIVE TRANSMISSION.

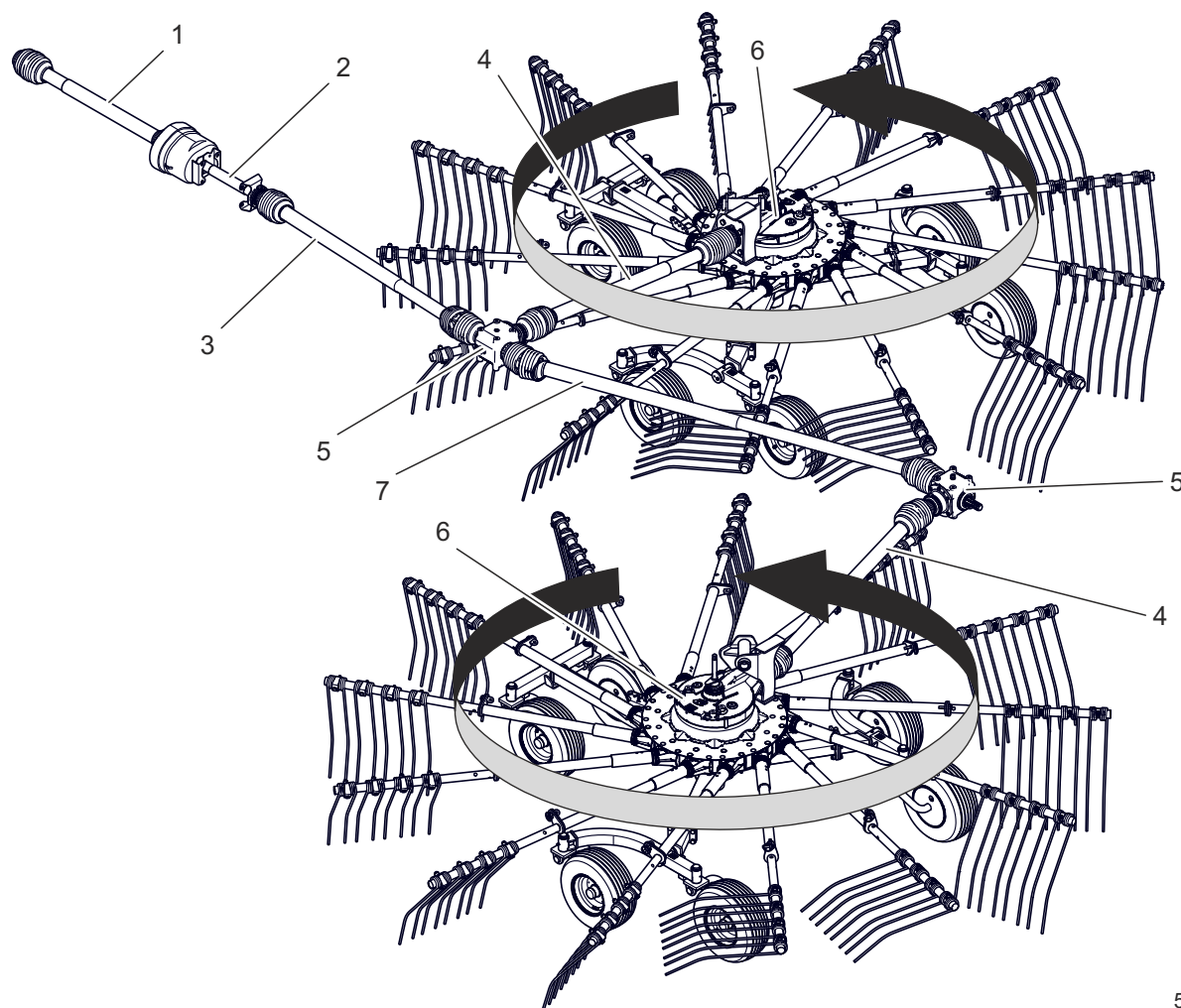

578-G.04-1

**Figure 3.4** Design of drive transmission system

(1) wide-angle PTO shaft (50°) for connection with tractor

(3) PTO shaft of the gear drive with backstop clutch

(5) bevel gear

(6) rotor transmission

(2) driving shaft

(4) PTO shaft with overload clutch

(7) intermediate shaft



#### IMPORTANT

Do NOT exceed the PTO rotation speed of 540 rpm.

Torque is transmitted from the tractor PTO through a wide-angle PTO shaft (1) to the driving shaft (2). Next, torque is transferred

by PTO shaft with backstop clutch (3) and intermediate drive shaft (7) to bevel gears (5). Torque is transferred from the bevel gear to the rotor transmissions (6) by two PTO shafts with overload protection clutch (4). The rotor transmissions rotate in the direction indicated by arrows in the figure.

G.1.7.578.05.1.EN

## 3.6 HYDRAULIC SYSTEM

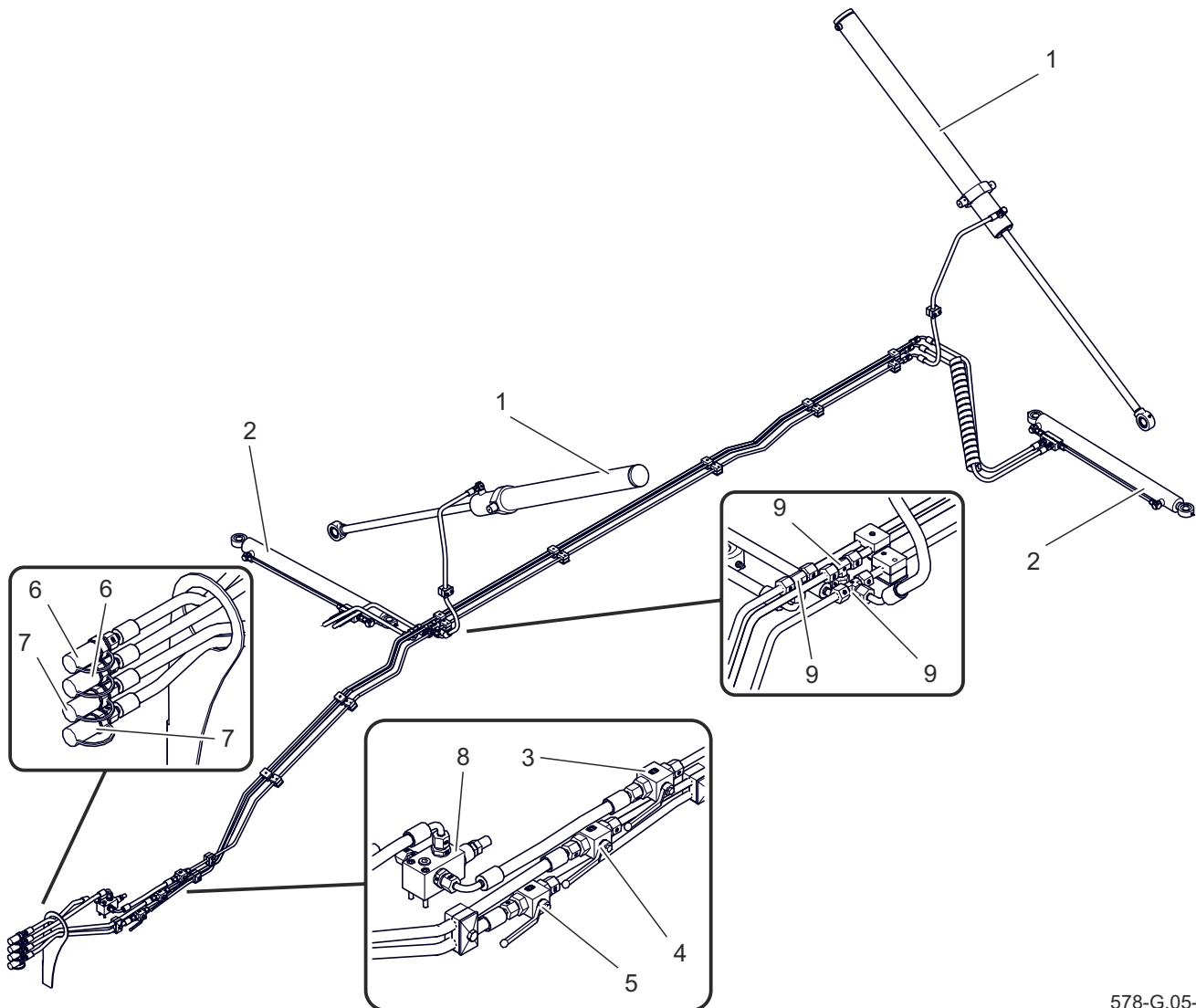

578-G.05-1

**Figure 3.5** Hydraulic system design

(1) hydraulic cylinder for raising / lowering

(3) valve for locking raising / lowering cylinders

locking valve

(6) lifting / lowering hydraulic quick couplers

(7) hydraulic quick coupler for controlling the adjusting hydraulic cylinders

(2) hydraulic cylinder for setting

(4), (5) adjusting hydraulic cylinder

(8) overflow valve (9) tee fitting

The hydraulic system is used for controlling the raking arms and adjusting the raking width. The hydraulic system is supplied from the tractor external hydraulic system through hydraulic quick couplers. Quick couplers for controlling the lifting

/ lowering cylinders (1) should be connected to the section with floating position. In such configuration the pistons of both lifting/lowering hydraulic cylinders can move freely. Consequently, the raking assemblies can adjust to uneven terrain.

Overflow valve (8) stabilizes and adjust maximal pressure in the hydraulic system. It protects hydraulic system from unpredictable overload. The valve is adjusted using a knob with the possibility of securing the settings with a lock nut.

Working width of the rotary rake is controlled with the use of hydraulic cylinders (2) and locking valves (4) and (5). Quick couplers (7) should be connected to one double acting section in the tractor.

G.1.7.578.06.1.EN

## 3.7 LIGHTING SYSTEM

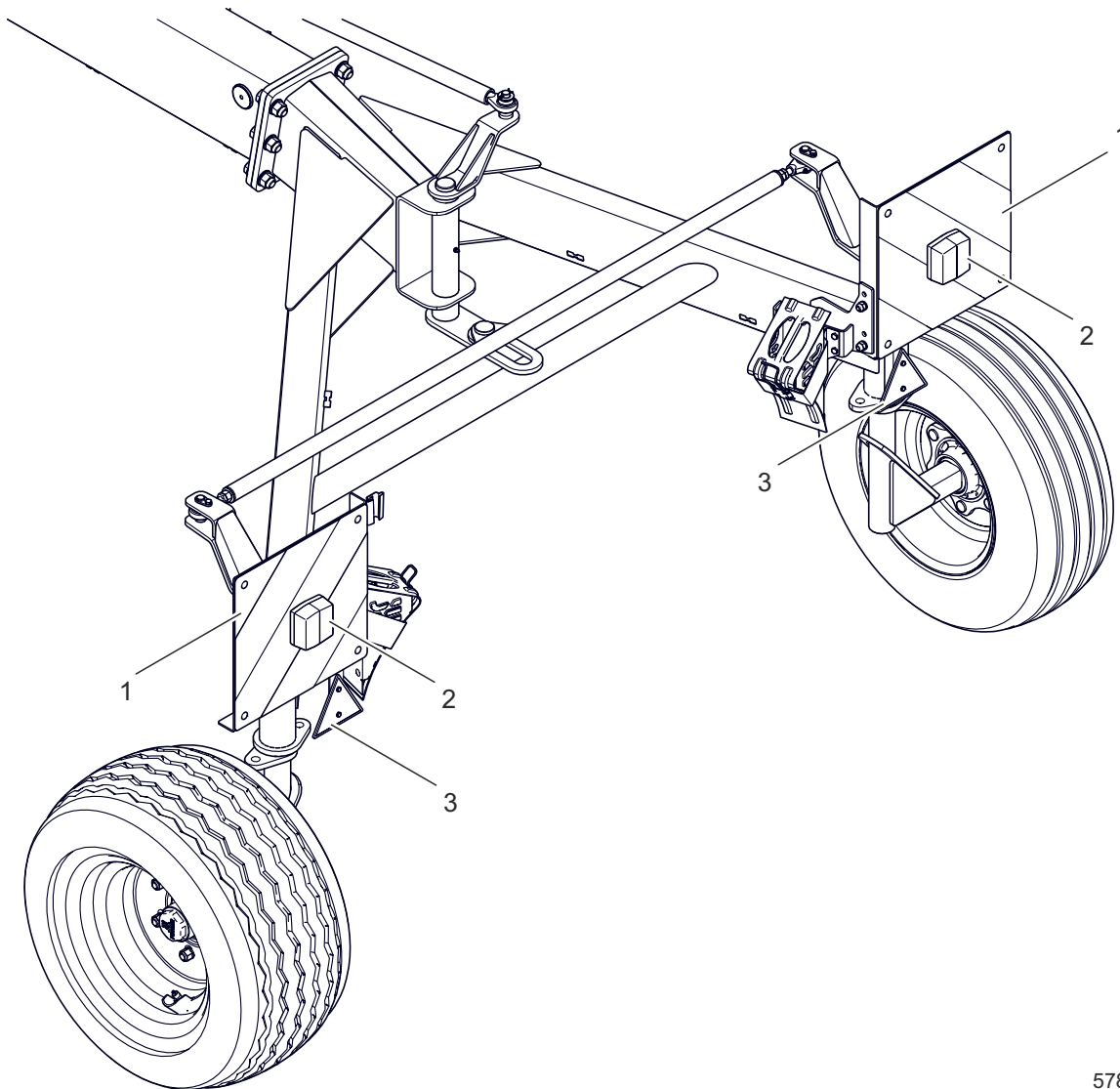

578-G.06-1

**Figure 3.6** Positioning of electrical system components and reflective elements

(1) warning board

(2) rear lamp

(3) warning reflective triangle

The rotary rake electrical system is designed for supply of 12 V DC. Connection of the electrical system with the tractor should be made through an appropriate connection lead that is part of the machine's standard equipment.

**Table 3.2.** Electrical system diagram markings

Symbol	Function
GP	7-pin socket, front
ZP	Rear right lamp assembly
ZL	Rear left lamp assembly



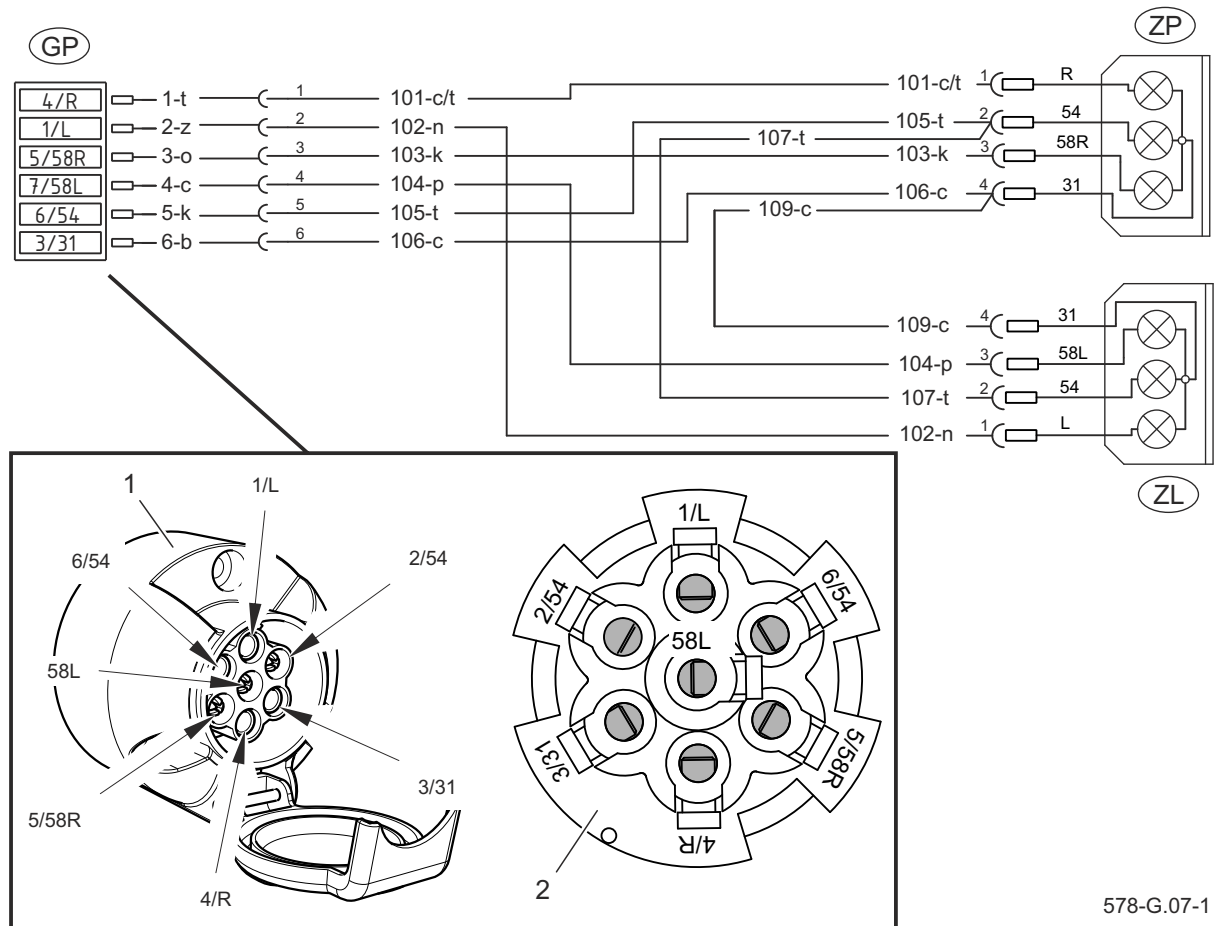

578-G.07-1

**Figure 3.7** Electrical system diagram

Marking according to table (3.2), (3.3) (1) socket side

(2) view from the wiring harness

**Table 3.3.** Conduit colour marking

Symbol	Colour
B	White
C	Black
K	Red
N	Blue
P	Orange
T	Green
C/T	Black and green
O	Brown
Z	Yellow

**Table 3.4.** Markings of connection socket's connections

Marking	Function (lead colour)
1/L	Left indicator (yellow)
2/54	unused
3/31	Ground (white)
4/R	Right indicator (green)
5/58R	Rear right parking light (brown)
6/54	STOP light (red)
58L	Rear left parking light (black)

G.1.7.578.07.1.EN



# SECTION 4

---

CORRECT USE

## 4.1 CONNECT THE MACHINE TO THE CARRIER VEHICLE



### IMPORTANT

Prior to attaching the machine, check the technical condition of the machine and tractor hitch system and connection elements of the hydraulic and electrical systems.

Ensure compatibility of oils in tractor and machine hydraulic systems.



### DANGER

When hitching, there must be nobody between the machine and the tractor. When hitching the machine, tractor driver must exercise due caution and make sure that nobody is present in the hazard zone.

The machine can be connected to an agricultural tractor if all electrical and hydraulic connections and the linkage on the agricultural tractor meet the machine manufacturer's requirements. The machine's wheels must be chocked. Ensure sufficient visibility during hitching.

In order to attach the rotary rake to tractor, proceed as follows:

- Remove the safety device (9).
- Reversing the tractor bring the lower three point linkage connection points (C) of the tractor close to pins (1) of the rotary rake.
- Set links (C) of tractor at appropriate height.
- Turn off tractor engine, secure cab to prevent unauthorised access.
- Connect lower pins (1) with linkage

arms (C) and lock with the aid of cotter pins,

- Connect hydraulic lines to the tractor.

*The line plugs (6) should be connected to the section with the floating position. Connect the plugs of lines (7) to the double acting section in the tractor. Plugs should be marked in order to exclude the possibility of wrong connection.*

- Lift rotary rake using tractor three point linkage.



### DANGER

Use only genuine pins and safeguards to hitch the machine to the carrier vehicle.



### IMPORTANT

Before you connect the electrical wires and hydraulic system lines, carefully read the Operator Manual of the carrier vehicle and observe all manufacturer's recommendations



### DANGER

When connecting the hydraulic lines to the tractor, make sure that the tractor and rotary rake hydraulic system are not under pressure.

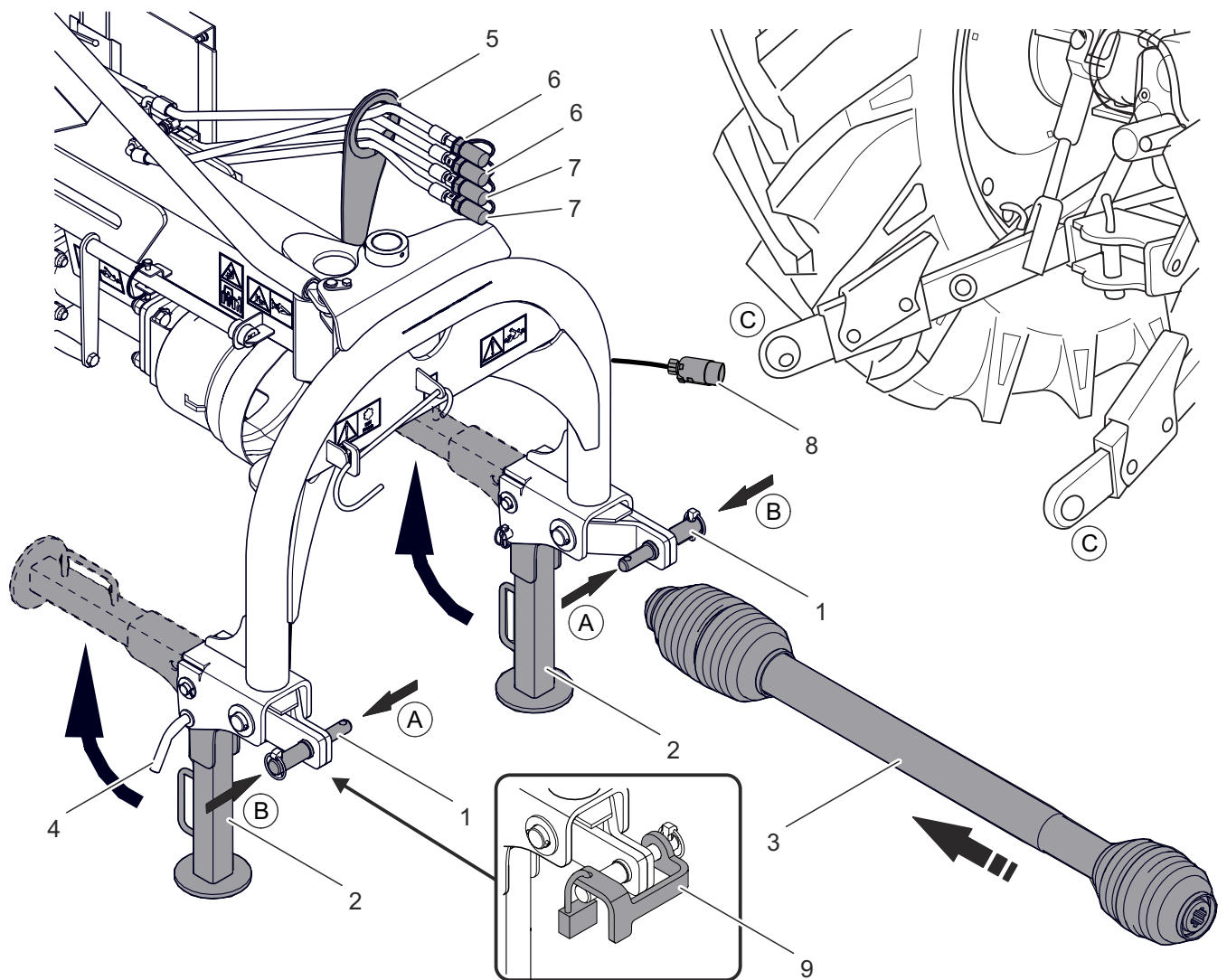

578-H.01-2

**Figure 4.1** Hitching to tractor

(1) lower linkage pin (2) support (3) PTO shaft for connection with tractor, (4) pin with cotter pin (5) line bracket (6)(7) hydraulic line plugs (8) lighting system cable plug (9) safety device  
 (A) - category I attachment points (B) - category II attachment points (C) lower links of the tractor's three-point linkage

- Lift the supports (2) and secure it with pins and cotter pins (4).

*Lower links of the tractor three-point linkage must be set at the same height.*

- Connect the plug (8) of the electric lighting system power cable.
- Connect the articulated telescopic shaft (3) to the PTO of the carrier

(tractor) and secure it with safety



**DANGER**

Before connecting the PTO shaft it is absolutely necessary to carefully read the Operator Manual attached by the Manufacturer of the shaft and observe the instructions contained in it. Before connecting to the carrier vehicle, check technical condition of shaft guards as well as completeness and condition of protecting chains.

chains.

---

*Make sure that shaft ends on both the tractor and rotary rake fit well and the linkage is properly secured.*

---

**TIP**

The proper alignment of the PTO shaft of the implement carrier (tractor) with the shaft of the machine's drive system significantly extends the life of the drive shaft.

**IMPORTANT**

Hydraulic and electric lines should be routed in such a way that they do not get caught in the moving parts of the machine and the carrier and are not exposed to kinking or cutting during turning.

H.1.7.578.01.1.EN

## 4.2 TRANSPORTING THE MACHINE

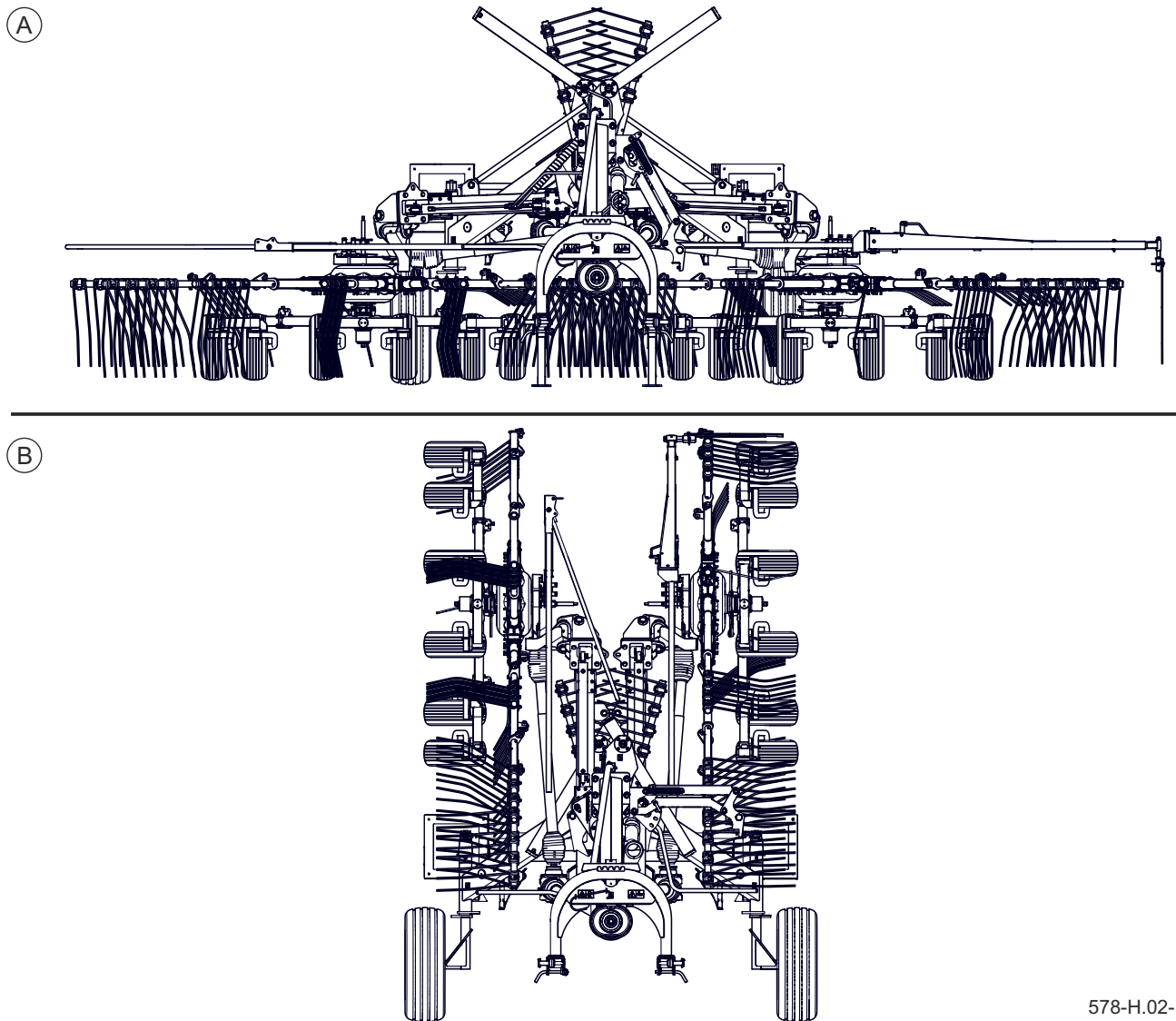

578-H.02-1

**Figure 4.2** Rake positions

(A) working position

(B) transport position



### DANGER

Before setting the rotary rake in working position or transport position make sure that there are no bystanders in the danger zone.



### IMPORTANT

Parking supports must be maximally raised during machine operation or travel.



### DANGER

Only transport the machine with the telescopic shaft disconnected.

For transport to place of work and back, set the rotary rake in transport position. In order to set the machine from working

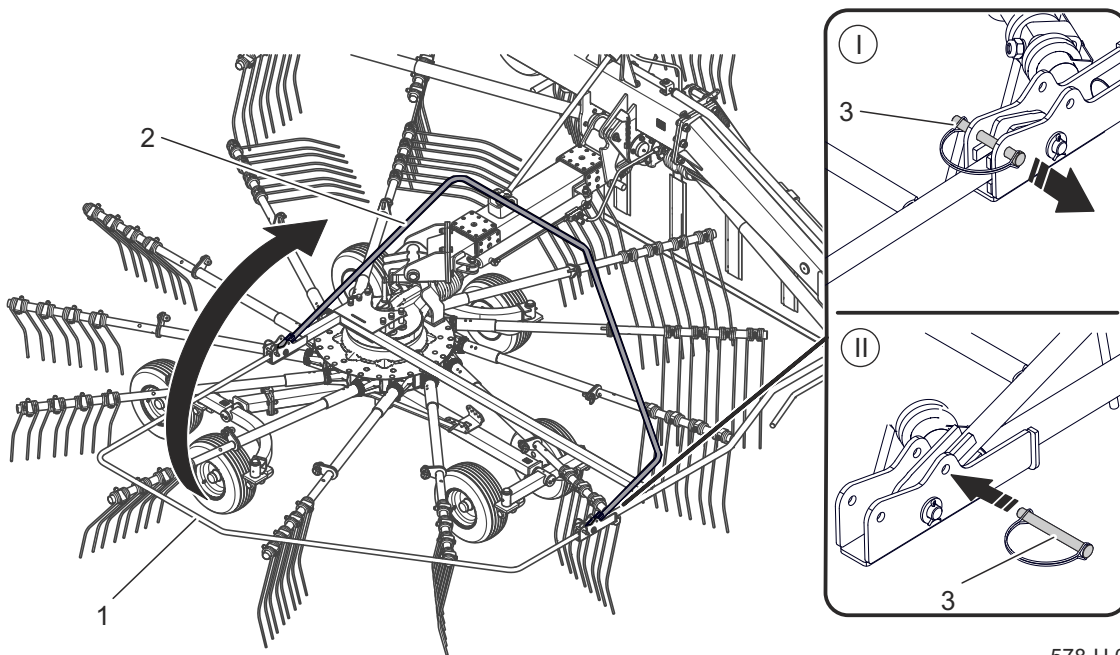

578-H.03-1

**Figure 4.3** Operation of the protective covers

(1) cover in the working position, (2) cover in the transport position, (3) cotter pin

position to transport position (B) - (FIGURE 4.2), proceed as follows:

- Move the protective shields from the working position (1) to the transport position (2) in order to reduce the overall transport width (Figure 4.3).

*(I) take the cotter pin out (3), then fold protective cover to (2)*

*position, (II) Secure protective cover in transport position using cotter pin (3).*

- Disassemble eight raking arms located on the outer side of raking assemblies - figure (4.4).

*In order to disassemble the raking arm (1), take out securing*

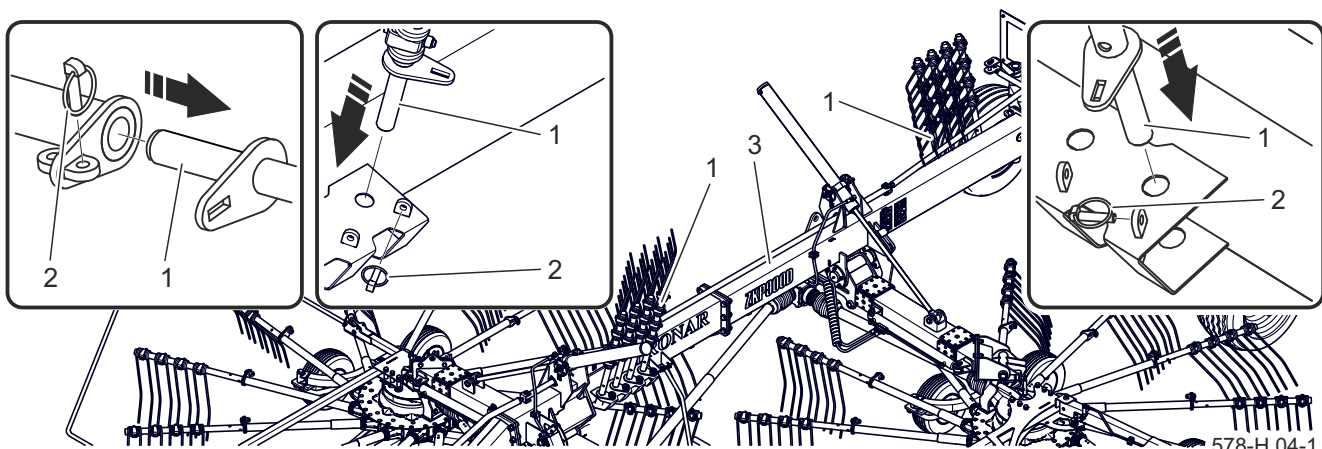

578-H.04-1

**Figure 4.4** Install the raking arms

(1) raking arm (2) - securing cotter pin (3) main frame



**DANGER**

Raking arms should be dismantled and mounted with tractor engine turned off. Remove the key from the ignition, ensure that unauthorised persons do not have access to the tractor. Immobilise the tractor with parking brake.

*cotter pin (2) and pull the raking arm out of its mount in the raking assembly gear. Place the raking arms in the seats on the main frame (3) and secure them with cotter pins (2).*

**IMPORTANT**

The raking arms in the transport position are secured only with the use of cotter pins, which are used to fasten the raking arms in the working position.

- Set the swath forming shield (1) to the transport position (B) - figure (4.5).

*While holding the swath forming shield handle (3), pull pin (4) in the direction of the arrow and hold it in this position. Raise the swath forming shield (1) and*

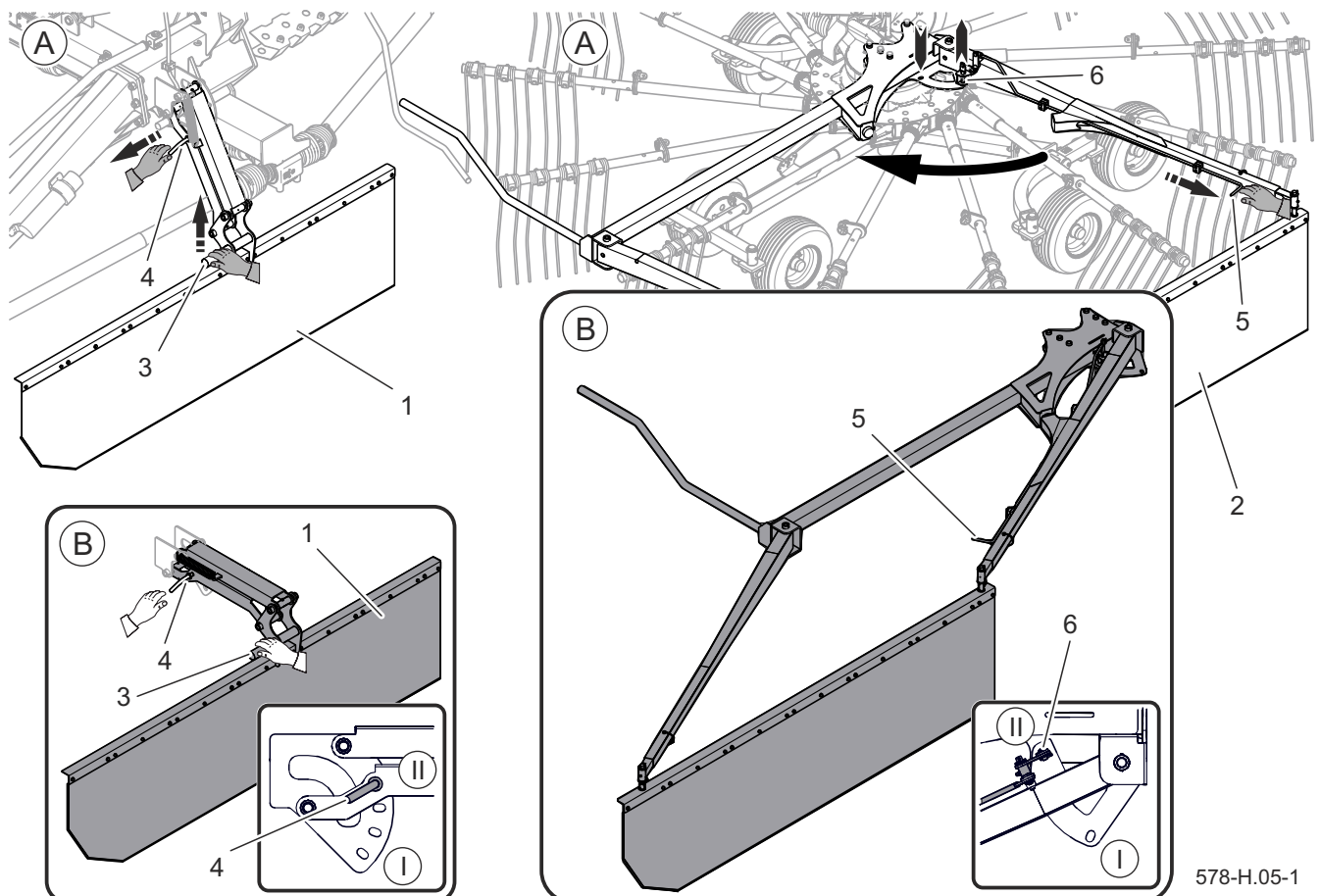

578-H.05-1

**Figure 4.5** Operate the swath forming shields

(A) swath forming shield in working position, (B) swath forming shield in transport position

(1)(2) swath forming shield (3) forming shield handle (4) forming shield pin (5) arm of the swath forming shield lock mechanism (6) pin of the swath forming shield lock mechanism

lock it in transport position by releasing the pin (4) - pin position II.

- Set the swath forming shield (2) to the transport position (B) - figure (4.5).

*Grasp the arm of the locking mechanism (5) and pull in the direction of the arrow. Holding the arm of the locking mechanism (5), slide the swath forming shield (2) in the direction of the arrow. Lock the swath forming shield in transport position by releasing the arm of the locking mechanism (5) - pin (6) in position II.*

- Set the locking valve (4) of lifting/lowering hydraulic cylinders in open position I – figure (4.6).



## DANGER

Turn off PTO drive before lifting the raking assemblies. Engaging the drive during lifting or when the raking assemblies are raised will damage the telescopic shafts and gears.

- Set the locking valves (5) and (6) of the raking width adjusting hydraulic cylinders in closed position 0.
- Bend the beam catches (2) by tightening the cables, and then, controlling the hydraulic cylinders, raise the carrying arms with raking assemblies until the beam catches (2) are locked in the hitch pins (3).

*The raking assemblies will be automatically locked when they are in vertical position.*

- Make sure that catch (2) keeps the

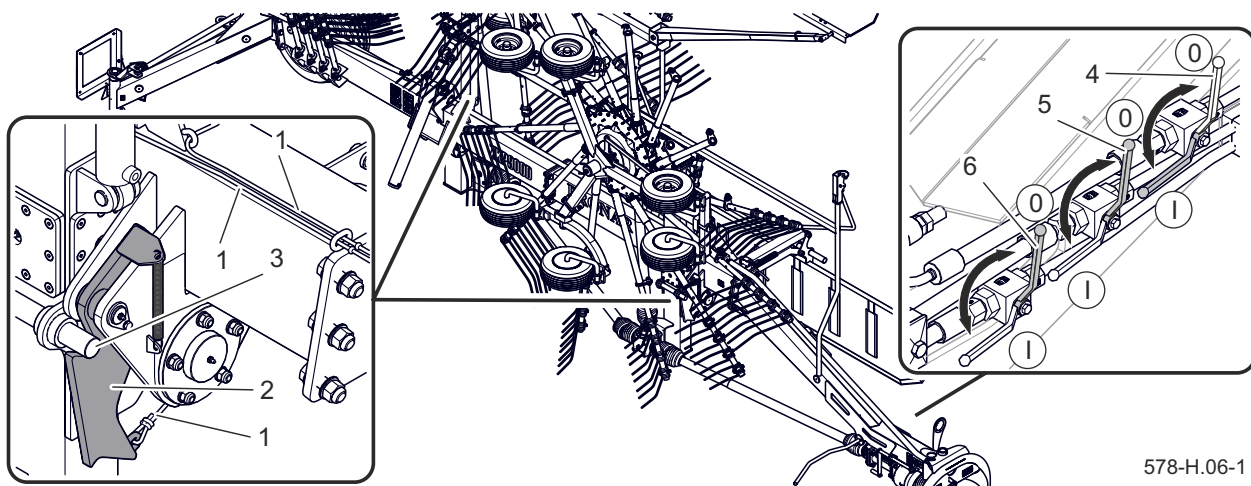

578-H.06-1

**Figure 4.6** Setting the rotary rake in transport position

(1) cylinder lock cable, (2) beam catch (3) hitch pin (4) locking valve of lifting/lowering hydraulic cylinders, (5), (6) locking valves of the working width adjusting hydraulic cylinders

raking assembly in vertical position.

- Close valve (4) by switching it to „0” position.
- Prior to moving off, check the lights.

H.1.7.578.02.1.EN

## 4.3 MACHINE OPERATION



### DANGER

During machine operation do not occupy a different position than that of the operator in the tractor cab. Do NOT leave the cab, when the machine is in operation.  
Do NOT stay between the carrier and the machine.



### DANGER

When driving the machine on uneven terrain, exercise particular caution and reduce the travel speed as the carrier and the machine may become damaged or overturned.

### SETTING THE ROTARY RAKE TO WORKING POSITION

After transporting the machine to the workplace, change its configuration from transport to operating configuration. Preparing of the machine for work must only take place exclusively on level and stable surface. Perform the following actions in order to set the rotary rake in working position:

- Release beam catches (2) by pulling cable (1) (figure (4.6)) and by operating the tractor hydraulic circuit, lower lifting arms with raking assemblies so that the wheels touch the ground and set tractor hydraulic circuit in float position,
- Turn off tractor engine and remove the key from the ignition switch,



### DANGER

Before setting the rotary rake in working position or transport position make sure that there are no bystanders in the danger zone.

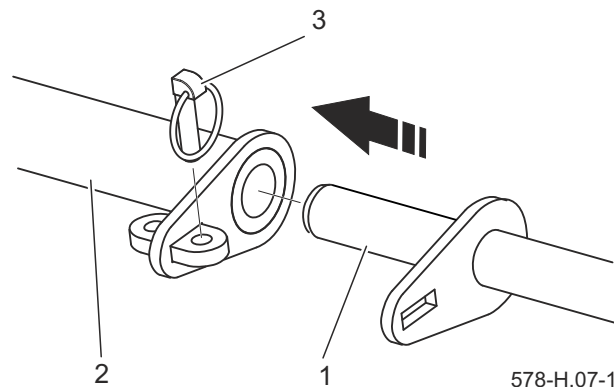

578-H.07-1

**Figure 4.7** Install the raking arms

- (1) raking arm (2) arm mount  
(3) - securing cotter pin

immobilize the tractor with parking brake and secure against unauthorized access.

- If the raking arms (1) were disassembled, assemble them by sliding them into arm mount (2) and secure with cotter pin (3) – figure (4.7).
- Set the swath forming shield (1) to working position (A) - figure (4.5).

*While holding the swath forming shield handle (3), pull pin (4) in the direction of the arrow and hold it in this position. Lower the swath forming shield (1) and lock it in working position*

*by releasing the pin (4) - pin position I.*

- Set the swath forming shield (2) to working position (A) - figure (4.5).

*Grasp the arm of the locking mechanism (5) and pull in the direction of the arrow. While holding the arm of the locking mechanism (5), move the swath forming shield (2) to the working position. Lock the swath forming shield by releasing the arm of the locking mechanism (5) - pin (6) in position I.*

- Set the locking valve (4) of lifting/lowering hydraulic cylinders in open position I – figure (4.6).

- Change protective covers from transport position (2) to working position (1) - figure (4.3).

### SETTING THE RAKING WIDTH

Depending on type of hay crop and type of machines working on the field after the rotary rake, appropriate working width can be set. If raking width is increased, the swath width is also increased.

Perform the following actions in order to change working width:

- Operating the hydraulic cylinders (1), raise the lifting arms (2) together with raking assemblies slightly above the swath.

*Valve (4) should be set in „I” position - figure (4.8).*

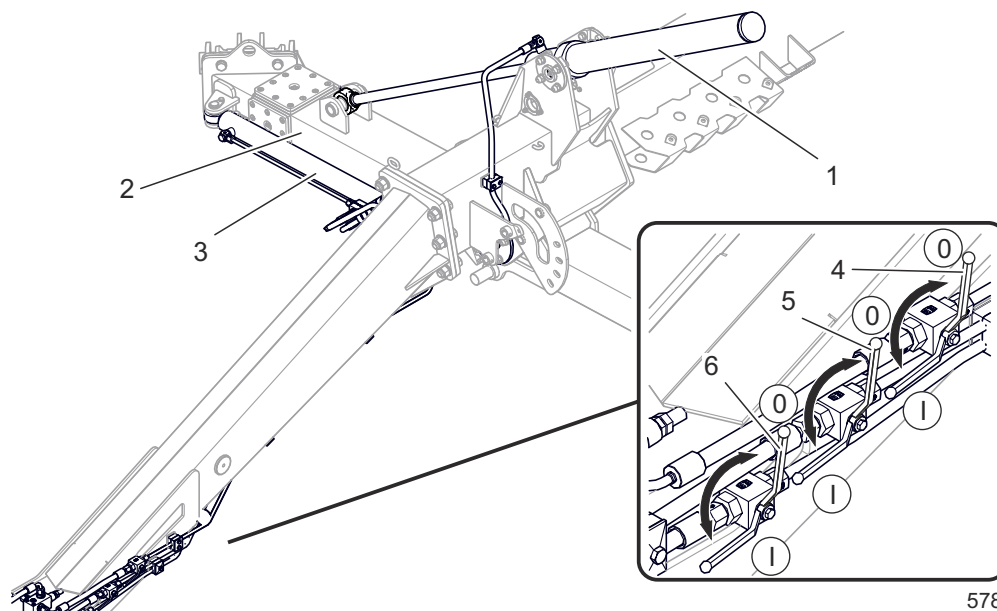

578-H.08-1

**Figure 4.8** Setting the rotary rake width

(1) lifting/lowering hydraulic cylinder (2) support frame (3) working width adjusting hydraulic cylinder (4) locking valve of lifting/lowering hydraulic cylinders (5),(6) locking valves of the working width adjusting hydraulic cylinders

- Set locking valves (5) and (6) of the raking width adjusting hydraulic cylinders in open position „I”
- Operating the hydraulic cylinders (3), set proper raking width.
- Lower lifting arms so that the wheels of the raking assemblies touch the ground.
- When a proper working width is set, valves (5) and (6) is locked by switching them to 0 position.

### SET THE RAKING HEIGHT

Adjust the raking height after lowering the machine to the ground. In order to adjust the raking height, do the following - figure (4.9):

- Park tractor and rotary rake on flat level ground,
- Set rear three point linkage in position adjustment mode.

*Set the height of the tractor*

### DANGER

Adjustment of rotary rake's working height must be done with the tractor engine turned off. Remove the key from the ignition, ensure that unauthorised persons do not have access to the tractor. Immobilise the tractor with parking brake.

*lower three-point linkage forks in such a manner as to ensure that the raking assemblies are set horizontally or slightly inclined forward.*

- Unscrew lock nut (2) anticlockwise.
- Adjust the height of the spring tines so that they lightly touch the ground surface.

*Turn the crank (1) clockwise (A) to raise the raking assembly.*

*Turn the crank (1) counter clockwise (B) to lowers the raking assembly.*

- Tighten lock nut (2).

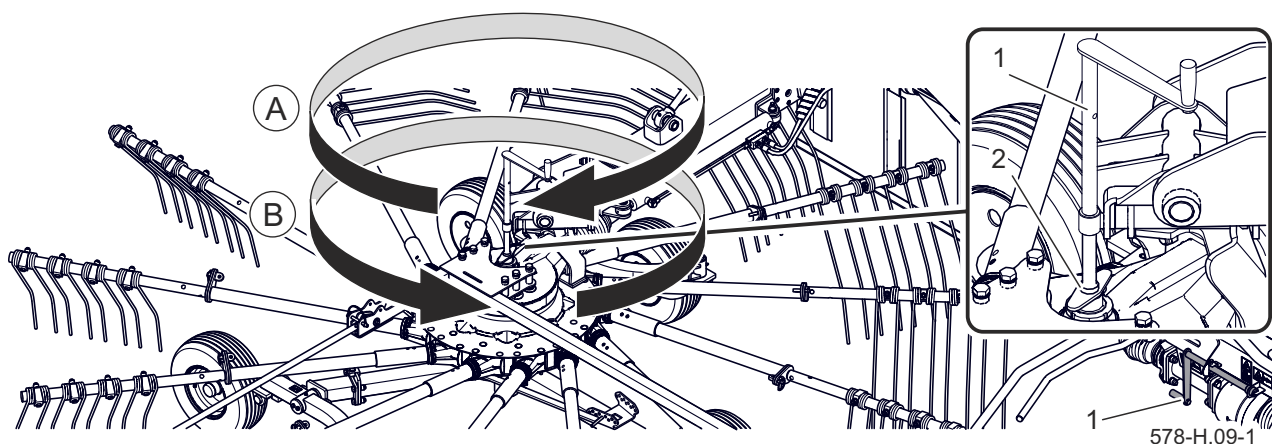

**Figure 4.9** Set the raking height  
 (A) raising of the raking assembly (B) lowering of the raking assembly  
 (1) crank (2) lock nut

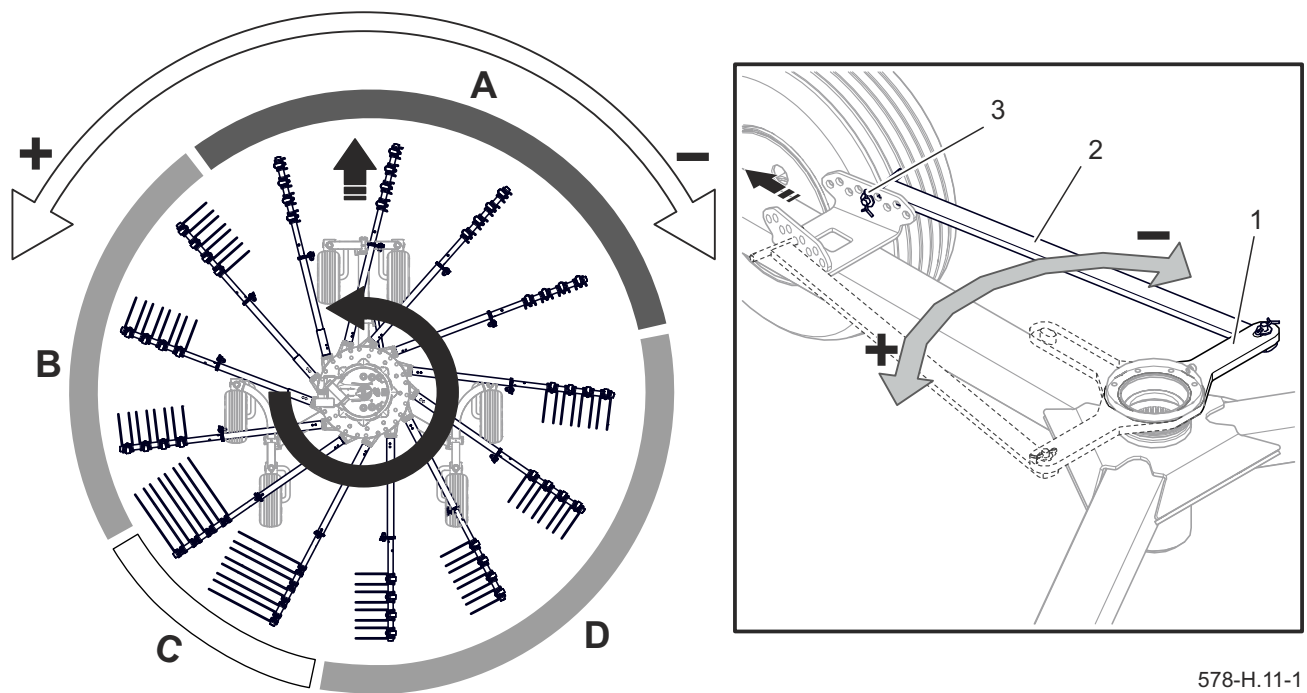

578-H.11-1

**Figure 4.10** Adjust raking phases

(A) arms in the operating position (B) raising arms

(C) raised arms

(D) lower the arms (1) raking phase adjustment lever (2) lever cable (3) cotter pin

Raking height selection depends on the amount of cut hay crop, degree of dampness, raking speed and the ground over which the rotary rake is moving. If springtines are too high from the ground there is a risk that not all of the swath will be raked. If the spring tines are too low from the ground, the swath may be contaminated with earth, turf, stones etc. Furthermore, there is an increased risk of damage to the rotary rake, mainly to the spring tines and their mounting to the arms. Height selection should be checked frequently during raking and if necessary the setting should be corrected

## ADJUST RAKING PHASES

Adjust raking phases by changing the position of the lever (1) (figure *Adjusting raking phases*) to guarantee the formation of a perfect swath ready for the next stage of work. After setting the lever (1) to the required position, secure the lever (2) cable with a cotter pin (3).

## RAKING

If the rotary rake is correctly set for working in the field, is totally serviceable and its technical condition causes no concerns one may commence work.

Selective control valve lever of the tractor external hydraulic system used for controlling operation of the lifting/lowering

hydraulic cylinders should be set in "floating" position. Consequently, the raking assemblies can adjust to uneven terrain.

Ground speed is adjusted during working. Ground speed should be adjusted in such a way as to ensure that hay crop is completely raked and the swath is properly formed. Allowable revolution speed of PTO shaft is 540 rpm. However, one should set such a revolution speed as to prevent unnecessary spreading of hay crop. Revolution speed of PTO shaft should be reduced when a drier swath is raked.

The revolution speed of the shaft and the ground speed depend on several factors, including size of swath, degree of moisture, length of swath, type of ground, therefore the selection of appropriate working parameters rests on the person operating the rotary rake. During machine operation the linkage system shall be set in position adjustment work mode.



## DANGER

Before starting the carrier engine make sure that the PTO drive is disengaged. Otherwise, the machine may start uncontrollably and endanger the life and health of bystanders.

The machine may only be started when all its protection guards are installed properly.

Before engaging PTO drive, make sure that there are no bystanders, especially children, near the machine. Maintain proper visibility of machine during work

Other persons should be at a safe distance from the rotary rake during work because of the danger that objects may be thrown (stones, branches) from beneath springtines.



## IMPORTANT

Do not start the machine with PTO speed higher than the allowable one.

## TIP

The height of raking arm setting should be checked frequently during working.

During turning or reversing, PTO shaft drive should be disengaged and the lifting arms of raking assemblies should be raised slightly above the ground.

H.1.7.578.03.1.EN



## 4.4 UNHITCH THE MACHINE FROM THE CARRIER VEHICLE



### DANGER

Before unhitching the machine from the carrier vehicle, turn off the carrier vehicle's engine, engage parking brake and secure cab against access of unauthorised persons.  
Be especially careful when unhitching the machine from the carrier vehicle.



### DANGER

Reduce pressure prior to disconnecting the hydraulic system.



### DANGER

Do NOT use the securing chains to support the shaft while machine is parked or when transporting the machine.

Machine unhitched from the carrier vehicle must be placed on level, sufficiently hard surface in such a manner as to ensure that it is possible to connect it again.

In order to disconnect the rotary rake from the carrier vehicle, proceed as follows:

- Lower the supports (5) and secure it with pins and cotter pins (6).
- Set the rotary rake using three-point linkage until supports (5) fully rest on the ground.
- Place chocks under rotary rake wheel.

*Wheel chocks shall be so placed that one of them is in front of the wheel and the second is behind it.*

- Switch off engine, remove key from ignition and engage parking brake.
- Reduce residual pressure in the hydraulic system by moving the appropriate control lever of the hydraulic circuit in the carrier.
- Disconnect from the carrier vehicle the hydraulic lines (3) and the electric lighting system supply cable (7) and place them on the cable bracket (4),
- Disconnect PTO shaft (1) from carrier PTO drive and place on bracket (2),
- Disconnect lower pins of the rotary rake and drive tractor away.
- Secure the machine against unauthorized use with the safety device (8).

Disconnecting the PTO shaft is not essential but it is recommended. Turning sharp corners, especially in field conditions may be hindered because of this. If the shaft is not taken off, is essential to remember not to engage the PTO drive of the tractor during transport travel.

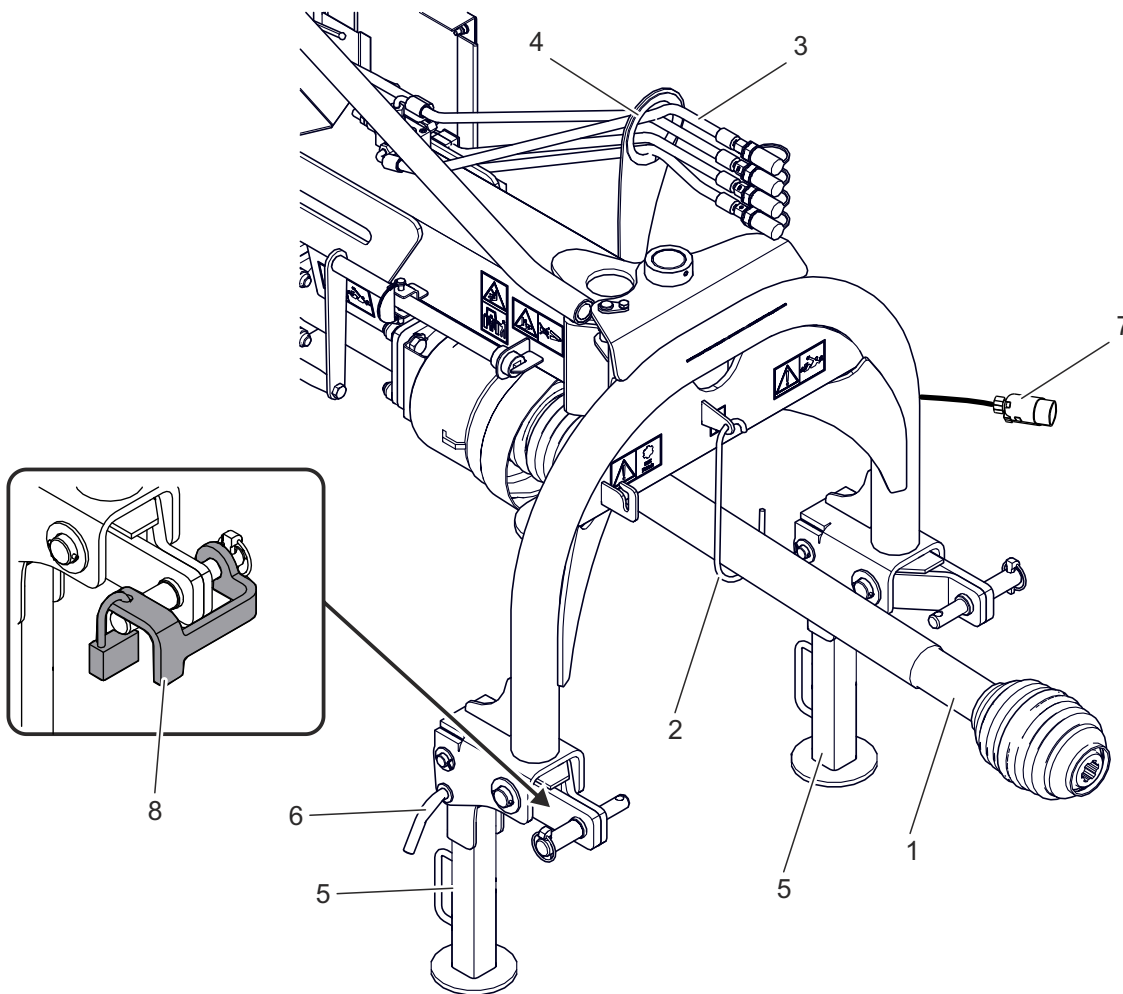

578-H.10-2

**Figure 4.11** Disconnecting the rotary rake

(1) PTO shaft for connection with tractor (2) shaft bracket (3) hydraulic lines (4) line bracket (5) support (6) pin with cotter pin (7) electric wire (8) safety device

H.1.7.578.04.1.EN

## 4.5 PROPER USE AND MAINTENANCE OF TYRES

- When working on tyres, the machine should be secured against rolling by placing chocks under the wheels.
- Repair work on the wheels or tyres should be carried out by persons trained and entitled to do so. This work should be carried out using appropriate tools.
- Checking the tightening of nuts should be made after the first use, after the first day of work, and then at regular intervals every 50 hours of work. The inspection should be repeated individually if a wheel has been removed from the wheel axle. Wheel nuts should be tightened according to recommendations provided in the section 5. *MAINTENANCE*.
- Regularly check and maintain the correct pressure in tires in accordance with the instructions (especially if not used for an extended).
- Air pressure in tyres should be also checked during the whole day of intensive work. Please note that higher temperatures could raise tyre pressure by as much as 1 bar. At high temperatures and pressure, reduce speed.
- Do not release air from warm tyres to adjust the pressure or the tyres will be underinflated when temperatures return to normal.
- Tyre valves should be protected with the appropriate caps to avoid soiling.
- Do not exceed the maximum machine speed.
- When machine is operated all day, check temperature of tyres.
- Avoid potholes, sudden manoeuvres or high speeds when turning.

H.1.7.578.05.1.EN

## 4.6 CLEAN THE MACHINE

Machine should be cleaned depending on requirements and before longer idle periods. Before using pressure washer the user is obliged to acquaint himself with the operating principles and recommendations concerning safe use of this equipment.

### MACHINE CLEANING GUIDELINES

- To clean the machine, use only clean running water or water with a cleaning detergent additive with neutral pH.
- The use of pressure washers increases the effectiveness of washing, but be careful when working. During washing, washer nozzle may not be closer than 50 cm from the surface being cleaned.
- Water temperature should not exceed 55°C.
- Do not direct the water jet directly at machine components and equipment, i.e. valves, hydraulic cylinders, lights, electric and hydraulic plugs, electric connections, information and warning stickers, rating plate, line connections and lubrication points etc. High water jet pressure may damage these elements.
- For cleaning and maintenance of plastic coated surfaces it is recommended to use clean water or special preparations designed for this purpose.
- Do not apply organic solvents, preparations of unknown origin or other substances, which may cause damage to lacquered, rubber or plastic surfaces. In the event of doubt it is recommended to make a test on an unseen surface area.
- Surfaces smeared with oil or grease should be cleaned by application of white spirit or other degreasing agents and then washed with clean water with added detergent. Follow the cleaning agent manufacturer instructions.
- Detergents should be kept in original containers, optionally in replacement containers, but very clearly marked. Preparations may not be stored in food and drink containers.
- Ensure flexible lines and seals are clean. The plastic from which these elements are made may be susceptible to organic substances and some detergents. As a result of long-term reaction of some substances, the ageing process may be accelerated

**DANGER**

Carefully read the instructions for application of detergents and maintenance preparations.

While washing with detergents wear appropriate protective clothing and goggles protecting against splashing.

Switch tractor engine off and disengage PTO shaft before cleaning the machine.

and risk of damage increased. Rubber elements should be maintained with the aid of special preparations after previous thorough washing.

- Observe the rules of environmental protection and wash the machine in a place designed for this purpose.
- Washing and drying the machine must take place at temperatures above 0°C.
- After finishing washing wait until the machine is dry and then grease all inspection points according to recommendations. Remove excess oil or grease with a dry cloth.

H.1.7.578.06.1.EN

## 4.7 STORAGE

- After cleaning, inspect the whole machine, inspect technical condition of individual elements. Repair or replace any used or damaged components.
- Machine should be stored in a closed or roofed building inaccessible for unauthorized people and animals.
- The machine unhitched from the carrier vehicle should be placed on level, sufficiently hard surface in a way as to ensure that it is possible to hitch it again.
- Secure the machine against unauthorized use with the safety device.
- If the machine will not be used for a long time, it is essential to protect it from adverse weather, especially rust and accelerated tyre deterioration. The machine should be very carefully washed and dried.
- Corroded places should be cleaned of rust, degreased and protected using undercoat paint and then painted with surface paint according to colour scheme.
- In the event of a prolonged storage, it is essential to lubricate all components regardless of the date of the last lubrication.
- Wheel rims and tyres should be carefully washed and dried. During longer storage of unused machine it is recommended that every 2 to 3 weeks the machine may be moved a bit so that the place of contact of tyres with ground is changed. The tyres will not be deformed and maintain proper geometry. Also, air pressure in tyres should be inspected from time to time and, if necessary, pressure should be increased to an appropriate value.
- PTO shafts should be stored in horizontal position.

H.1.7.578.07.1.EN

# SECTION 5

---

MAINTENANCE

## 5.1 BASIC INFORMATION

When using the machine, regular inspections of its technical condition and the performance of maintenance procedures are essential, which keep the machine in good technical condition. In connection with this, the machine user is obliged to perform all the maintenance, inspection and adjustment procedures defined by the Manufacturer, according to the specified schedule.

Repairs during the warranty period may only be performed by the Authorised Points of Sale and Service (APSS).

The warranty will be void if you attempt unauthorized repairs, modify factory settings



### IMPORTANT

The machine must not be used when not in working order.  
Repairs during the warranty period may only be performed by authorised service points.

or use the machine not as intended (not described in this manual).

Warranty inspection of the machine may be carried out only by an authorized warranty service point.

After the warranty period, we recommended that these inspections should be performed by specialised workshops.

I.1.7.578.01.1.EN



## 5.2 PERIODIC MAINTENANCE SCHEDULE

**Table 5.1.** Inspection categories

Category	Description	Carried out by	Frequency
A	Inspection daily	Operator	Inspection conducted daily before the first start or every 10 hours of continuous operation in shift mode.
B	Maintenance inspection	Operator	Inspection performed every 50 hours of operation. Before commencing work, perform also all the activities included in the scope of daily inspection.
C	Maintenance inspection	Operator	Inspection performed every 250 hours of operation or every 6 months, whichever comes first. Before starting work, also perform all inspection steps every 50 hours of operation.
D	Maintenance inspection	Operator	Inspection performed every 500 hours of operation or every 12 months, whichever comes first. Before starting work, also perform all inspection steps every 250 hours of operation.
E	Maintenance inspection	Service <sup>(1)</sup>	Inspection carried out every 4 years of the machine use

(1) - post-warranty service

**Table 5.2.** Inspection schedule

Description of activities	A	B	C	D	E
Check connection of the rotary rake to the tractor's linkage	•				
Check air pressure in tyres and technical condition of wheels	•				
Inspection of connection plugs and sockets	•				
Check protective shields	•				
Check technical condition of PTO shaft <sup>(1)</sup>	•				
Check transmission oil level and add if necessary	•				
Check mounting of spring rake tines to raking arms	•				
Check correct operation of lights and indicators of the rotary rake	•				
Inspect the hydraulic system	•				
Check if the wheels are properly tightened		•			
Checking wheel axle bearings for slackness			• <sup>(2)</sup>		
Change gear oil		• <sup>(3)</sup>		•	
Replace hydraulic lines					•
Lubrication	See table: <i>Trailer lubrication schedule</i>				
Inspection of nut and bolt connections	See section: <i>"Inspection of nut and bolt connections"</i>				
<p>(1) in accordance with the PTO shaft's Operator Manual  (2) after the first month of use, every 6 months of use  (3) first change</p>					

## 5.3 HALF AXLE MAINTENANCE

Work connected with the repair, change or regeneration of half axle components should be entrusted to specialist establishments, having the appropriate technology and qualifications for this type of work.

The duties of the user include only inspecting and adjusting slackness of half axle bearings.

Change of grease in the axle shaft bearings and replacement of bearings and hub seals may be performed by specialist workshops only.

### PREPARATION PROCEDURES FOR INSPECTING AND ADJUSTING SLACKNESS OF HALF AXLE BEARINGS

- Hitch machine to tractor, immobilise tractor with parking brake
- Park tractor and machine on hard level ground.

*Tractor must be placed to drive forward.*

- Place securing chocks under the rotary rake's wheel opposite to wheel to be raised. Ensure that machine will not move during inspection.
- Raise the wheel (opposite to the side where chocks are placed).

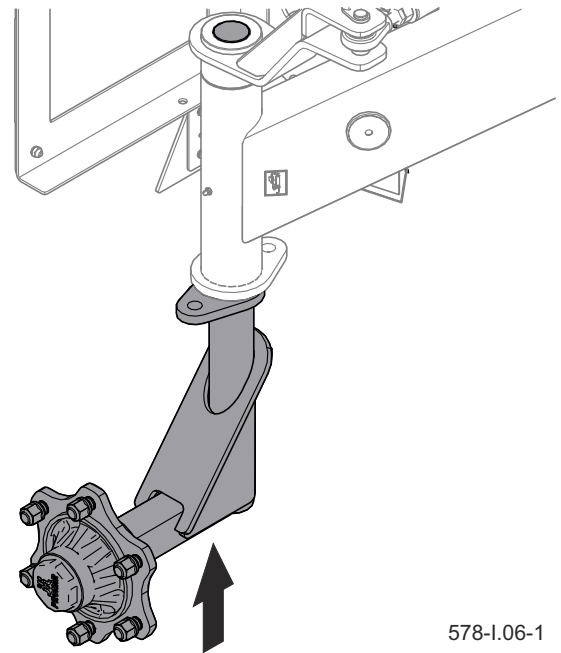

578-I.06-1

**Figure 5.1** Lifting jack support point



#### IMPORTANT

Before commencing work, the user must read the instructions for lifting jack and adhere to the manufacturer's instructions.



#### DANGER

The lifting jack must be stably supported by the ground and so must the half axle. Make sure that the machine does not roll when checking and adjusting the wheel half axle bearings slackness.

*Lifting jack should be positioned in the place indicated by the arrow in figure (5.1). Lifting jack must be suitable for machine weight.*

## CHECKING HALF AXLE SHAFT BEARINGS FOR SLACKNESS



Check wheel half axle bearings for looseness:

- after the first month of use,
- every 6 months of use.

- Turning the wheel slowly in both directions check that movement is smooth and that the wheel rotates without excessive resistance.
- Turn the wheel so that it rotates very quickly, check that the bearing does not make any unusual sounds.
- Moving the wheel try to detect slackness.

*You may use a lever placed under the wheel supporting the other end of the lever on the floor.*

- Repeat the procedure for the other wheel, remembering that the lifting jack must be on the side opposite to the chocks.

If slackness is felt, adjust bearings. Unusual noise made by the bearing may be a symptom of excessive wear, dirt or damage.

In such an event the bearing, together with sealing ring, should be replaced with new parts, or cleaned and greased again

### TIP

If hub cover is damaged or missing, contamination and dampness enter the hub, which causes significantly faster wear of bearings and hub seals. Bearing life is dependent on machine working conditions, loading, ground speed and lubrication conditions.

During inspection of bearings ensure that possibly detected looseness comes from the bearing and not from the axle system. Check condition of hub cover, if necessary replace it with a new cover. Only inspect bearings for looseness, when the machine is hitched to a tractor.

## ADJUST SLACKNESS OF HALF-AXLE SHAFT BEARINGS

- Take off hub cover (1).
- Take out cotter pin (3) securing castellated nut (2).
- Tighten castellated nut in order to eliminate slackness.

*Wheel should rotate with insignificant resistance.*

- Undo nut (not less than  $\frac{1}{3}$  of a turn) to align the nearest thread groove with the opening in wheel half axle pin.

*Wheel should rotate without excessive resistance. The nut must not be excessively tightened. Do not apply excessive pressure because working conditions of*

the bearings may deteriorate.

- Secure castellated nut with cotter pin and mount the hub cap.
- Delicately tap the hub cap with rubber or wooden mallet.

The wheel should turn smoothly without jamming and detectable resistance. Only adjust bearings, when the machine is hitched to a tractor.

**TIP**

The bearing clearance is easier to check and adjust if the wheel is removed.

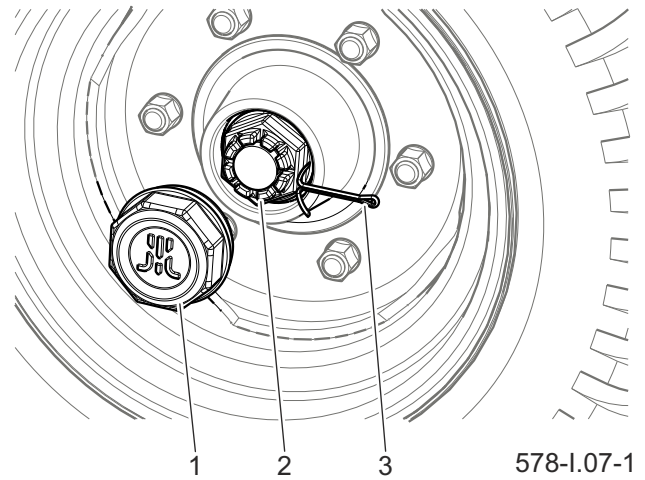

**Figure 5.2** adjustment of road wheel axle bearings

(1) hub cover

(2) castellated nut

(3) - securing cotter pin

I.1.7.578.03.1.EN

## 5.4 WHEEL MAINTENANCE

### CHECKING AIR PRESSURE IN TYRES AND TECHNICAL CONDITION OF WHEELS

Check tyres before you drive off when tyres are not warm, or after the machine has been parked for an extended period.

- Visually inspect if the tyres are properly inflated.
- If necessary, check air pressure using a manometer and inflate the tyre up to the recommended pressure.

*Required tyre pressure values are specified on the information decal (1) placed on the wheel rim.*

- While checking pressure pay attention to technical condition of wheels and tyres.

*Look carefully at tyre sides and check the condition of tread. Wheels should be inspected with regard to distortion, breaking of material, breaking of welds, corrosion, especially in the area of welds and contact with tyre.*

- In case of mechanical damage consult the nearest tyre service and check whether the tyre or wheel defect requires replacement.

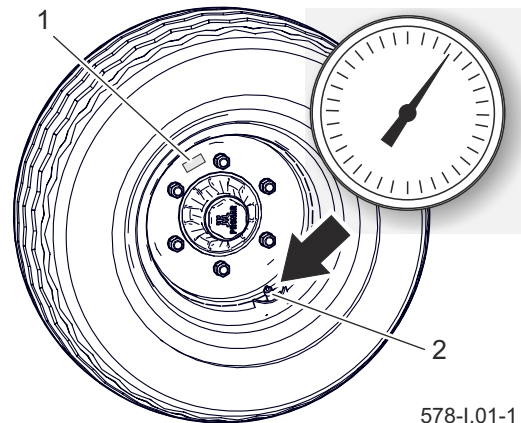

**Figure 5.3** Wheel

(1) decal

(2) valve



#### DANGER

Damaged tyres or wheels may be the cause of a serious accident.



#### IMPORTANT

Wrong air pressure in tyres accelerates the wear of tyres and may also lead to their permanent damage.

### REMOVE WHEEL

- Place chocks under the wheel that will not be dismantled.
- Ensure that machine is immobilised when wheel is being removed.
- Loosen wheel nuts according to the sequence shown in figure - *Sequence of nut tightening*.
- Place lifting jack and lift rotary rake.
- Dismount wheel.

## INSTALL WHEEL

- Clean half axle pins and nuts of contamination.

Do not grease thread of nuts and pins.

- Check condition of pins and nuts, if necessary replace them.
- Place wheel on hub, tighten nuts so that wheel rim tightly fits the hub.
- Lower the machine, tighten nuts according to recommended torque and given sequence.

## TIGHTENING NUTS

Nuts should be tightened gradually diagonally, (in several stages, until obtaining the required tightening torque) using a torque spanner.

Check tightening of half axle wheel nuts:

- after the first use of the trailer,
- after first day of work,
- at regular intervals (50 h).

The inspection should be repeated individually if a wheel has been removed from the wheel axle.

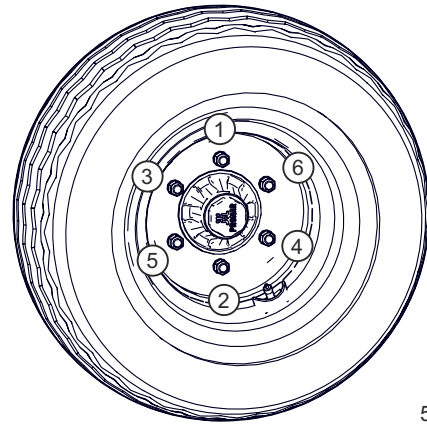

578-I.05-1

**Figure 5.4** Sequence of nut tightening



### IMPORTANT

Wheel nuts must not be tightened with impact wrench because of danger of exceeding permissible tightening torque, the consequence of which may be breaking the connection thread or breaking off the hub pin.

### TIP

Wheel nuts should be tightened using the torque of 270 Nm – M18x1.5 nuts.

The greatest precision is achieved using a torque spanner. Before commencing work, ensure that correct tightening torque value is set.

I.1.7.578.04.1.EN

## 5.5 INSPECTION OF CONNECTION PLUGS AND SOCKETS

Damaged connection body or socket body should be replaced. In the event of damage to cover or seal, change these elements for new reliable elements.

If the machine is unhitched from the tractor, connections should be protected by covers or placed in their designated sockets. Before the winter, it is recommended to preserve the seal with special preparations (e.g. silicon grease for rubber elements).

Each time before hitching the machine, inspect technical condition and cleanness of connectors and sockets in tractor. If necessary, clean or repair tractor sockets.

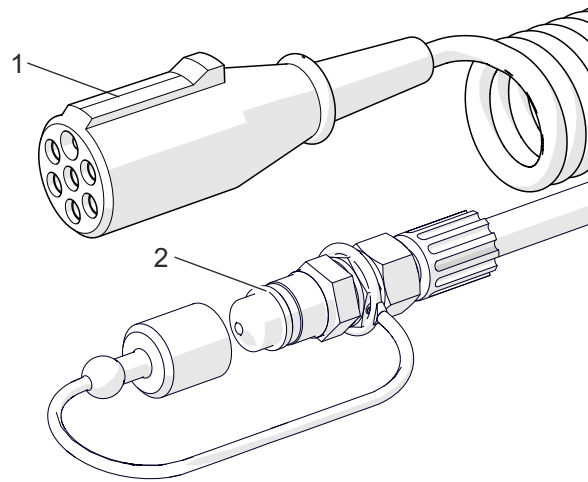

578-I.02-1

**Figure 5.5** Machine's connections  
(2) electrical plug      (3) hydraulic plug

I.1.7.578.05.1.EN



## 5.6 INSPECTION OF PROTECTIVE SHIELDS

Shields protect the machine user's health and life and the machine subassemblies against damage. Therefore, their technical condition must be checked before using the trailer. Any damaged or lost components must be repaired or replaced.

### PROCEDURE

- Check the protective shields for completeness and correct mounting.
- Visually inspect the technical



### DANGER

Do NOT use the machine with damaged or incomplete shields.

condition and completeness of the PTO shafts and their shields.

- If necessary, tighten the bolt connections fixing the shields.

I.1.7.578.06.1.EN

## 5.7 OPERATE TRANSMISSION



### DANGER

If the machine is hitched to the carrier, disengage the PTO, remove the key from the ignition and immobilize the vehicle with the parking brake before you inspect the machine.

Do NOT perform service or repair work under raised and unsupported machine.



### DANGER

**Do not touch the bevel gear after stopping the machine!** Due to the high oil temperature, the surfaces of the gears can reach high and dangerous temperatures.

When checking oil level and adding oil, use appropriate personal protection equipment i.e. protective clothing, safety shoes, gloves, safety goggles. Avoid contact of skin with oil.



### IMPORTANT

Repairs of the transmission during warranty period may only be performed at authorised mechanical workshops.

### MAINTENANCE OF BEVEL GEARS

Maintenance of the bevel gears is conducted during general inspection, change or topping up gear oil. In the event of damage to transmission, contact authorised service point in order to perform repairs.

#### CHECK OIL LEVEL

- Set the machine on a hard and level surface.
- Unscrew inspection plug (2).

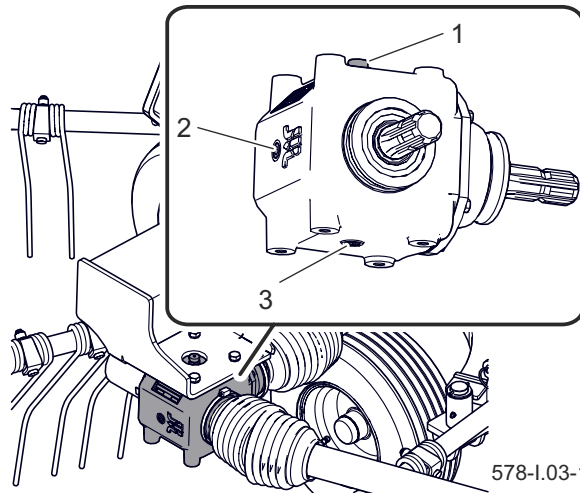

**Figure 5.6** Check oil level and change oil in bevel gears

(1) filler plug

(2) inspection plug

(3) drain plug



### IMPORTANT

Check oil level in the gears before each start of the machine.

During inspection, the gear must be turned off and the oil cooled down.

Avoid overfilling with oil. Excessive amount of oil can cause the temperature of the gear to rise too high. If a leak is noticed, carefully inspect seals and check oil level. Operating the transmission with insufficient amount of oil or without oil may cause permanent damage.

*Oil level should reach the lower edge of the inspection plug opening (2).*

- If necessary unscrew plug (1) and add oil to the required level. Tighten the plug

## CHANGE OIL

- Set the machine on a hard and level surface.
- Unscrew filler plug (1) and inspection plug (2).
- Unscrew drain plug (3) and drain oil to previously prepared container.
- If the oil manufacturer recommends flushing transmission, that operation should be performed according to the guidelines of the oil manufacturer.

*Guidelines may be detailed on packaging.*

- Tighten drain plug (3).
- Fill the transmission with oil to the required level.

*Oil level should reach the lower edge of the inspection plug opening (2).*



The first change of oil in the gear should be made after the first 50 hours of work. The next oil changes should be made every 500 hours or once a year (whichever occurs first).

### TIP

Lubricate the rake's bevel gears with gear oil SAE 90 EP (API GL-5 SAE 80W/90) adding 1.1 litres for each one.

- Tighten filler plug (1) and inspection plug (2).

Used oil should be taken to the appropriate facility dealing with recycling or regeneration of oils.

## MAINTENANCE OF ROTOR TRANSMISSIONS

The rotor transmissions of the raking assemblies are filled with grease and require no maintenance after the first filling. Maintenance of rotor transmissions involves general visual inspection and greasing according to *Lubrication* section. In the event of damage to transmission, contact authorised service point in order to perform repairs.

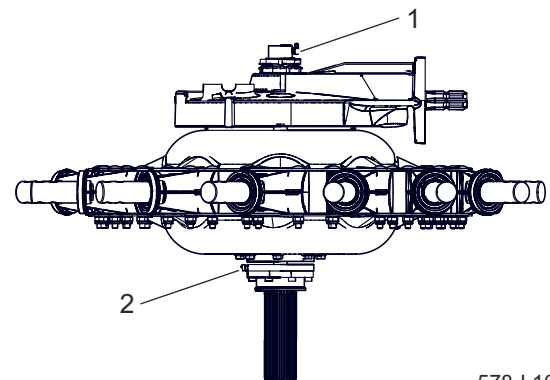

578-I.10-1

**Figure 5.7** Rotor transmission  
(1) adjusting bolt grease nipple  
(2) working mode change lever grease nipple

I.1.7.578.07.1.EN

## 5.8 CHECK AND REPLACE SPRINGTINES



### DANGER

Before beginning preparation work turn off tractor engine and remove the key from the ignition and engage tractor parking brake. Ensure that unauthorised persons do not have access to the tractor.

Spring tines and their mounting should be checked while working with rotary rake. Damaged elements should be replaced. It is not possible to repair springtines.

### CHANGING SPRINGTINES

- Unscrew nut (4).
- Disassemble mounting angle section (2), raking springtine safeguard (6) and bolt (3).

*Raking springtines safeguards are optional equipment.*

- Remove damaged springtine (1) from arm and mount new springtine.
- Install bolt, raking spring safeguard and angle section. Tighten the nuts using the correct tightening torque according to table *Tightening torque for nut and bolt connections*.

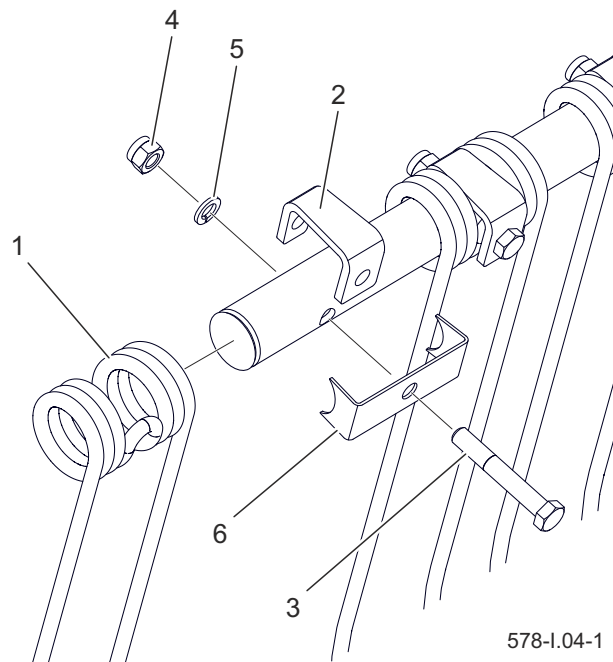

578-I.04-1

**Figure 5.8** Changing springtines

(1) spring tine (2) securing angle, (3) bolt, (4) self-locking nut (5) washer (6) raking springtines safeguards



Before starting work check condition of springtines connections to arms and locking cotter pins on raking arms frame in case they have fallen out.

**Table 5.3.** Springtine

Name	Part number	Quantity
Springtine	178N-02010300	104

I.1.7.578.08.1.EN

## 5.9 MAINTENANCE OF ELECTRICAL SYSTEM AND WARNING ELEMENTS

The duties of the user include the technical inspection of the electrical system and warning elements as well as the replacement of light bulbs.

### PROCEDURE

- Hitch rotary rake to tractor with appropriate connection lead.

*Check if the connection wire is reliable. Check connection sockets in tractor and rotary rake.*

- Check completeness and technical condition of machine lights.
- Check completeness of all reflectors.
- Before driving on to public road, check that the tractor is equipped with a warning reflective triangle.



### IMPORTANT

Do NOT travel with out of order lighting system. Damaged lamp lenses, and burned-out bulbs must be replaced immediately before travelling. Lost or damaged reflectors must be replaced.

### TIP

Before driving off, make certain that all lamps and reflectors are clean.



### DANGER

Do not independently repair electrical system, except items described in this section. All electrical system repairs must be performed only by suitably qualified personnel.

I.1.7.578.09.1.EN

## 5.10 HYDRAULIC SYSTEM MAINTENANCE



### IMPORTANT

Before starting work, visually inspect the hydraulic system components.

The duties of the user related to the hydraulic system maintenance include checking the technical condition and tightness of hydraulic cylinders, hydraulic lines and hydraulic connectors.

The hydraulic system of new machine is factory filled with AGROL U hydraulic oil. Because of its composition, the oil is not classified as a dangerous substance, however long-term action on the skin or eyes may cause irritation.

In the event of contact of oil with skin wash the place of contact with water and soap. Do NOT apply organic solvents (petrol, kerosene). Contaminated clothing should be changed to prevent access of oil to skin. In the event of contact of oil with eye, rinse with large quantity of water and in the event of the occurrence of irritation consult a doctor. Hydraulic oil in normal conditions is not harmful to the respiratory tract. A hazard only occurs when oil is strongly atomised (oil vapour), or in the case of fire during which toxic compounds may be released.



### DANGER

The machine with a leaking hydraulic system must NOT be used.



### DANGER

When working with hydraulic system, use the suitable personal protection equipment i.e. protective clothing, footwear, gloves, eye protection. Avoid contact of skin with oil.



### DANGER

Oil fires should be quenched with carbon dioxide (CO<sub>2</sub>), foam or extinguisher steam. Do NOT use water for fire extinguishing!



The condition of hydraulic system should be inspected regularly while using the machine.

### TIP

The hydraulic system of the machine is filled with AGROL U oil (8 litres).

The hydraulic system must be tight. Inspect the seals when the hydraulic cylinders are completely extended. If oil is found on hydraulic cylinder body, check origin of leak. Minimum leaks are permissible with symptoms of "sweating", however in the event of noticing leaks in

the form of "droplets" stop using the machine until faults are remedied.

If an oil leak is found on hydraulic connections, tighten the connections. If this does not remedy the problem, replace the lines and connection components. Always exchange each mechanically damaged component.

If it is necessary to change hydraulic oil for another oil, check the recommendations of the oil Manufacturer very carefully. If it

is recommended to flush the system with the appropriate preparation, then comply with these recommendations. It should be ensured that the chemicals used for this purpose do not compromise the materials of the hydraulic system.

Spilt oil should be immediately collected and placed in a marked tight container.

Used oil should be taken to the appropriate facility dealing with recycling or regeneration of oils.

**Table 5.4.** Characteristics of AGROL U oil

Item	Name	Value
1	Kinematic viscosity at 100°C	10,0 – 11,5 mm <sup>2</sup> /s
2	Viscosity index, min.	>95
3	Pour point, max. [°C]	<-24
4	Base number mgKOH/g	9,9
5	Flash-point, [°C]	>230

**Table 5.5.** Hydraulic components tightening torque

Nut thread	Line diameter DN (cal)	Tightening torque [Nm]
M10x1   M12x1,5   M14x1,5	6 (1/4")	30÷50
M16x1,5   M18x1,5	8 (5/16")	30÷50
M18x1,5   M20x1,5   M22x1,5	10 (3/8")	50÷70
M22x1,5   M24x1,5   M26x1,5	13 (1/2")	50÷70
M26x1,5   M27x1,5   M27x2	16 (5/8")	70÷100
M30x1,5   M30x2   M33x1,5	20 (3/4")	70÷100
M38x1,5   M36x2	25 (1")	100÷150
M45x1,5	32 (1.1/4")	150÷200

I.1.7.578.10.2.EN

## 5.11 REPLACE HYDRAULIC LINES

Rubber hydraulic lines must be replaced every 4 years regardless of their technical condition. This should be done in specialised workshops.



### IMPORTANT

Flexible hydraulic lines must be replaced every 4 years due to their working characteristics and material (ageing, high pressure, variable loads).

I.1.7.578.11.1.EN



## 5.12 LUBRICATION

Lubrication of the machine should be performed according to the specified schedule or each time after washing the machine, regardless of the date of previous lubrication. Keep lubrication points clean as excessive amount of lubricant causes dirt to accumulate. Lubrication should be performed using generally available tools such as manually or foot operated pneumatic grease guns, etc. filled with a recommended grease.

Clean the lubrication points before lubricating. Check grease nipples. If necessary, supplement missing elements. Remove and wipe off excess oil or grease.

The drive shafts are to be lubricated as instructed in the shaft Operator's Manual provided the shaft manufacturer.

Change of grease in half axle hub bearings should be entrusted to specialised service points, equipped with the appropriate tools. According to the recommendations of the half axle Manufacturer, dismantle the entire hub, remove the bearing and individual sealing rings. After careful washing and inspection, mount lubricated elements. If necessary, bearing and seals should be replaced with new parts. Lubrication of half axle bearings shall be performed at least once in 2 years or every



### DANGER

Before beginning preparation work turn off tractor engine and remove the key from the ignition and engage tractor parking brake. Ensure that unauthorised persons do not have access to the tractor.



### IMPORTANT

Empty grease or oil containers should be disposed of according to the recommendations of the lubricant Manufacturer.

### TIP

When using the machine the user is obliged to observe lubrication instructions according to attached schedule. Excess lubricant causes depositing of additional contaminants in places requiring lubrication, therefore it is essential to keep individual machine components clean.

50,000 km. In the event of intensive use, lubrication should be performed more frequently.

**Table 5.6.** Lubrication schedule

Item	Lubrication point	Number of lubrication points	Type of grease (Table 9.2)	Frequency
1	Hub bearings	2	A	24M
2	Wheel half axle	2	A	60H
3	Axle system tension rod joint	2	A	60H
4	Tension rod joint I	1	A	60H
5	Tension rod joint II	1	A	60H
6	Steering arm pin	1	A	60H
7	Link pin	1	A	60H
8	Three-point linkage frame suspension pin	1	A	8H
9	Multi-splined drive shaft	2	A	20H
10	Axle system rocker arm pin	12	A	60H
11	Rocker arm axle pin	6	A	60H
12	Raking assembly suspension pin	4	A	60H
13	Forming shield arm pin	1	A	60H
14	Forming shield adjusting pin	2	A	60H
15	Forming shield hinge pin	1	A	60H
16	Arm pin	4	A	60H
17	Extendible arms slide surface	16	A	60H
18	Extension cylinder pin	4	A	120H
19	Load-bearing cylinder pin	6	A	60H
20	Connector and forming shield arm pin	4	A	60H
21	Adjustment bolt (threaded)	2	A	60H
22	Axle system guide sleeve	2	A	60H
23	Adjustment bolt (operating mode change lever)	2	A	60H
24	Hitch pin	2	A	60H
25	Bearing assembly	2	A	20H
26	PTO shafts *	*	*	*

27	Bevel gear **	2	E	500H
28	Rotor transmission ***	***	***	***
H - hour   D - day   M - month   BU - always before use				
* For detailed information on operation and maintenance please refer to Operator Manual enclosed with the shaft.				
** First change after 50 working hours				
*** The machine transmission gear is pre-filled with GADUS S2 V220AD 2 oil and require no maintenance after the first filling				

**Table 5.7.** Lubricants

Item	Symbol	Description
1	A	machine general-purpose grease (lithium, alkaline),
2	B	Grease for heavily loaded elements with addition of MoS <sub>2</sub> or graphite
3	C	anticorrosion preparation in aerosol
4	D	ordinary machine oil, silicon grease in aerosol
5	E	SAE 90EP (80W90 GL-5) transmission oil .

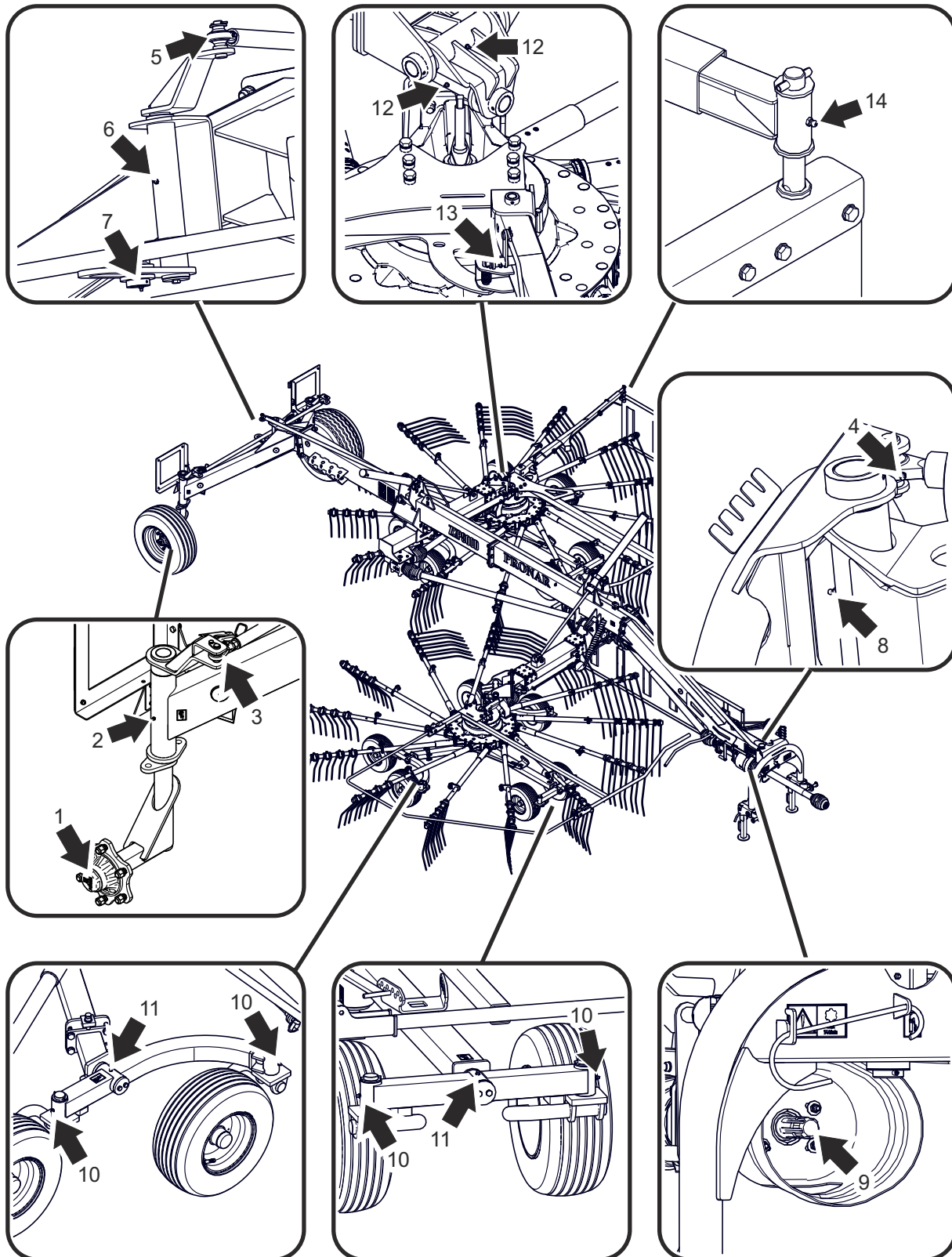

578-I.08-1

**Figure 5.9** Rotary rake lubrication points

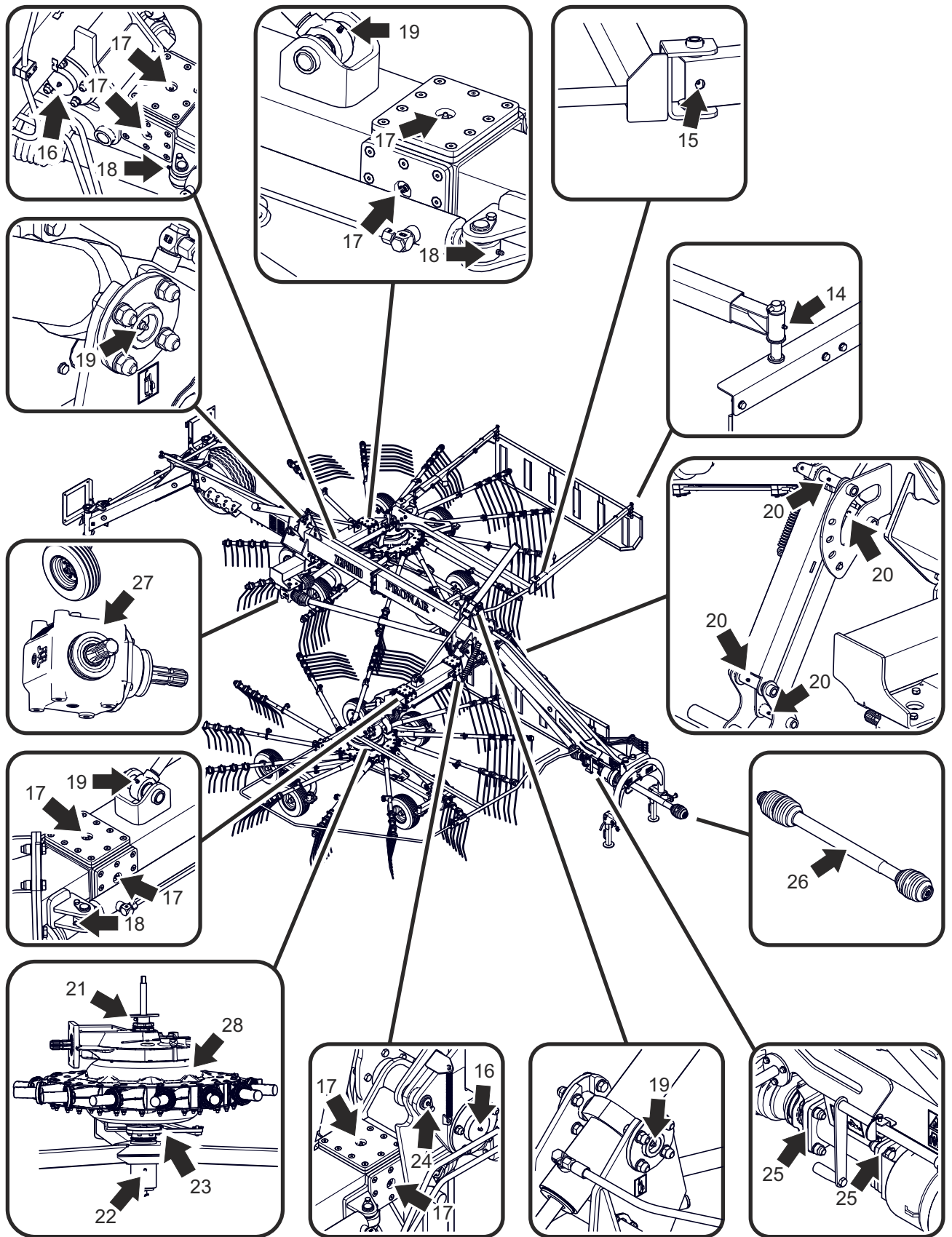

578-I.09-1

Figure 5.10 Rotary rake lubrication points

## 5.13 TIGHTENING BOLT CONNECTIONS

Before each use of the machine and during maintenance and repair work, confirm that all bolt connections are properly tightened. If any clearances in bolt connections are found, tighten bolt connections using appropriate tightening torque (Table )*Tightening torque for nut and bolt connections*, unless other tightening parameters are given. Recommended torque values apply to non-greased steel bolts.

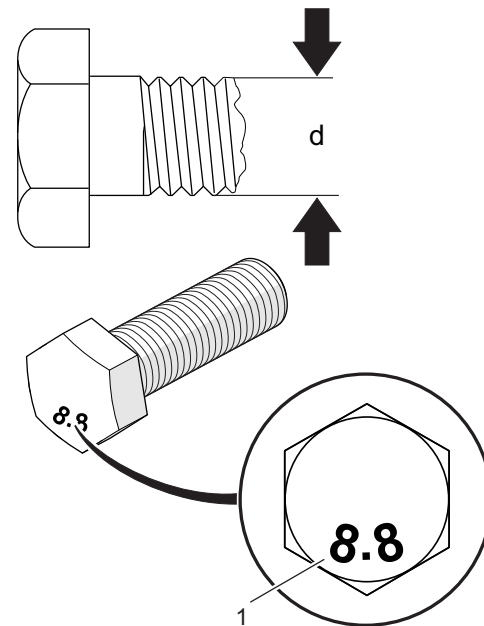

569-I.09-1

**Figure 5.11** Bolt with metric thread  
(1) resistance class (d) thread diameter

**Table 5.8.** Tightening torque for nut and bolt connections

THREAD MARKING [mm]	8.8	10.9
	TIGHTENING TORQUE [Nm]	
M6	10	15
M8	25	36
M10	49	72
M12	85	125
M14	135	200
M16	210	310
M20	425	610
M24	730	1,050
M27	1,150	1,650
M30	1,450	2,100
M32	1,450	2,100

## 5.14 TROUBLESHOOTING

**Table 5.9.** Troubleshooting

<b>Fault</b>	<b>Possible cause</b>	<b>Solution</b>
Excessive vibration during work	Damaged PTO shaft	Check shafts, if necessary replace
	Damaged raking assembly gear	Repair at an authorised service point
Excessive heating of gear	Incorrect oil level.	Check oil level and add oil.
	Wrong oil type.	Change the oil with the one recommended by the manufacturer.
	Damaged bearings.	Repair at an authorised service point
Leaking gear	Loss of tightness	Inspect seals, check tightening of bolts and check lubricant level.
Rotary rake drive units stop during raking	Damaged raking assembly gear	Repair at an authorised service point
	Damaged bevel gear	Replace or repair at authorised service point
Rotary rake arm cannot be lifted or lowered	Incorrectly connected or damaged quick coupler	Check quick couplers and manner of their connection
	Blocked cylinder lock	To unblock lock pull cable
	The tractor hydraulic system is out of order	Check condition of tractor hydraulic system
Some hay crop is left unraked (inaccurate raking)	Tractor PTO rotation speed too low	Maintain correct, constant PTO speed
	Incorrect inclination of raking assembly	Set raking assemblies horizontally or slightly inclined forward
	Worn or missing springtines	Install springtines or replace worn springtines
	Incorrect raking height	Set raking height according to section <i>Setting raking height</i>
Damaged springtines	Raking assemblies arms hight set to low	Set raking height according to section <i>Setting raking height</i>

I.1.7.578.14.1.EN





# ANNEX A

---

FIRST ASSEMBLY MANUAL

## PREPARATION

Due to its large overall dimensions, Pronar ZKP900D rotary rake is partially dismantled for shipment and transport on a motor vehicle. Before the first start, the rotary rake has to be assembled in order to be prepared for normal operation. It is absolutely necessary to carefully read this manual before assembling the rotary rake.

The persons who assemble the rotary rake should have sufficient know-how, appropriate technology and qualifications for this type of work.

The following parts of the rotary rake are disassembled before transport:

- complete raking assemblies with chassis - 2 items, raking arms - 26 items,
- 
- PTO shafts - 3 items



### IMPORTANT

Do NOT perform assembly work under raised and unsupported machine.

Exercise due caution while assembling the machine. Make certain that all safety conditions are adhered to.

During assembly work, the tractor and rotary rake must be protected against rolling.

Warning boards with lights are turned by 180° and bolted to axle system bracket. Single items and fasteners necessary for assembling the rotary rake are delivered in special bags.

After preliminary assembly, operation of the machine must be tested. All bolt and nut connections must be checked and retightened after 50 hours of work.

Z1.1.7.578.01.1.EN

# TURNING THE WHEELS

Wheels of the machine are turned inwards and locked in that position for shipment and transport on a motor vehicle. In order to turn the wheels to normal operating position:

- disconnect axle interlocks (2) by removing pins (3) - **(A)**,
- turn the axle steering knuckles (1) outwards by 180° - **(B)**,
- attach drawbar (6) to axle steering

**! IMPORTANT**

Do NOT use or tow the rotary rake on public roads in shipment configuration because it may tip over.

knuckles.

Insert pins (3) and secure with screw (4) and washer (5).

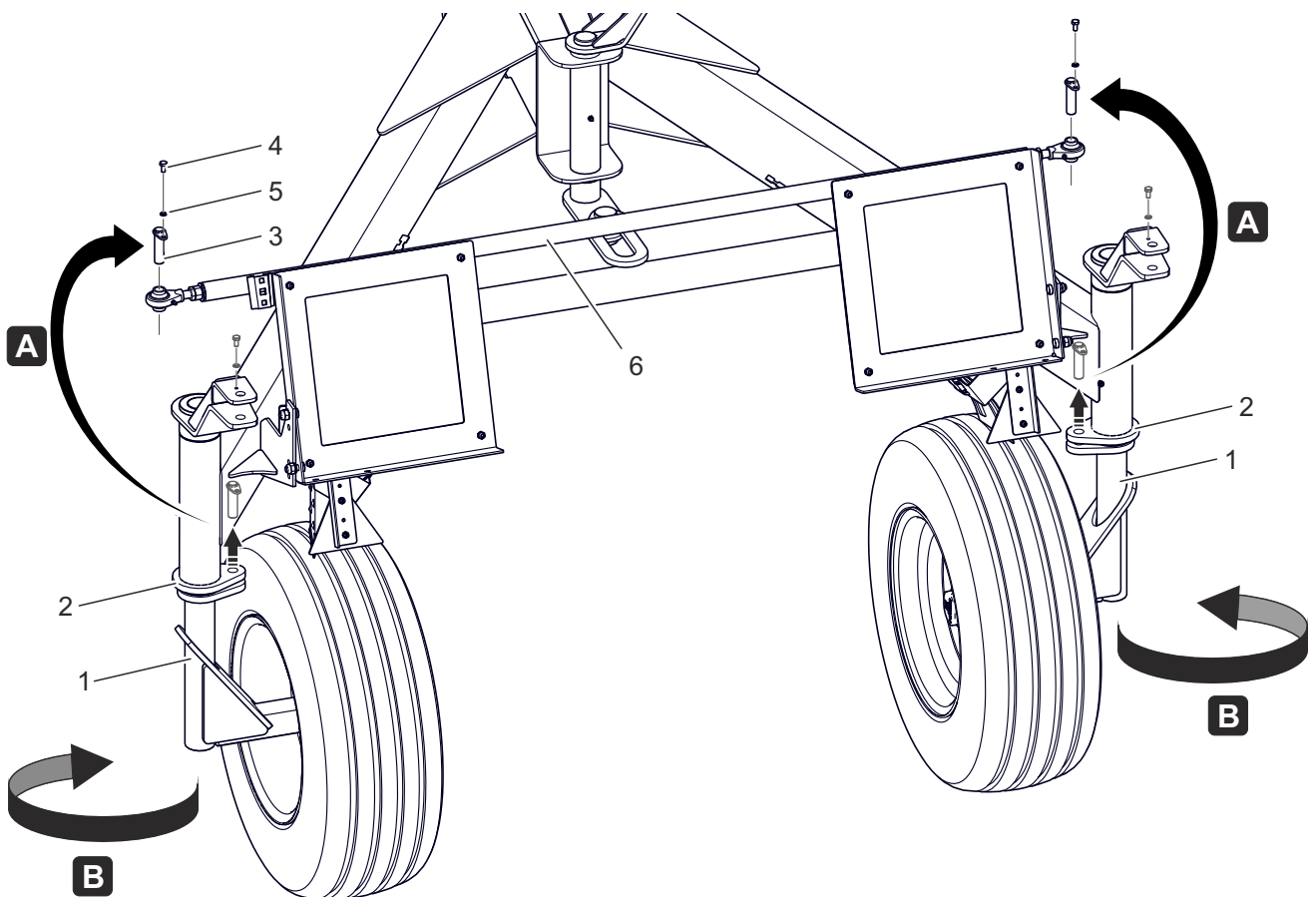

578-Z1.01-1

**Figure A.1** Turning the wheels

- (1) axle steering knuckle    (2) axle lock    (3) link pin    (4) bolt  
 (5)- spring washer        (6) drawbar

Z1.1.7.578.02.1.EN

## INSTALLING THE WARNING BOARDS

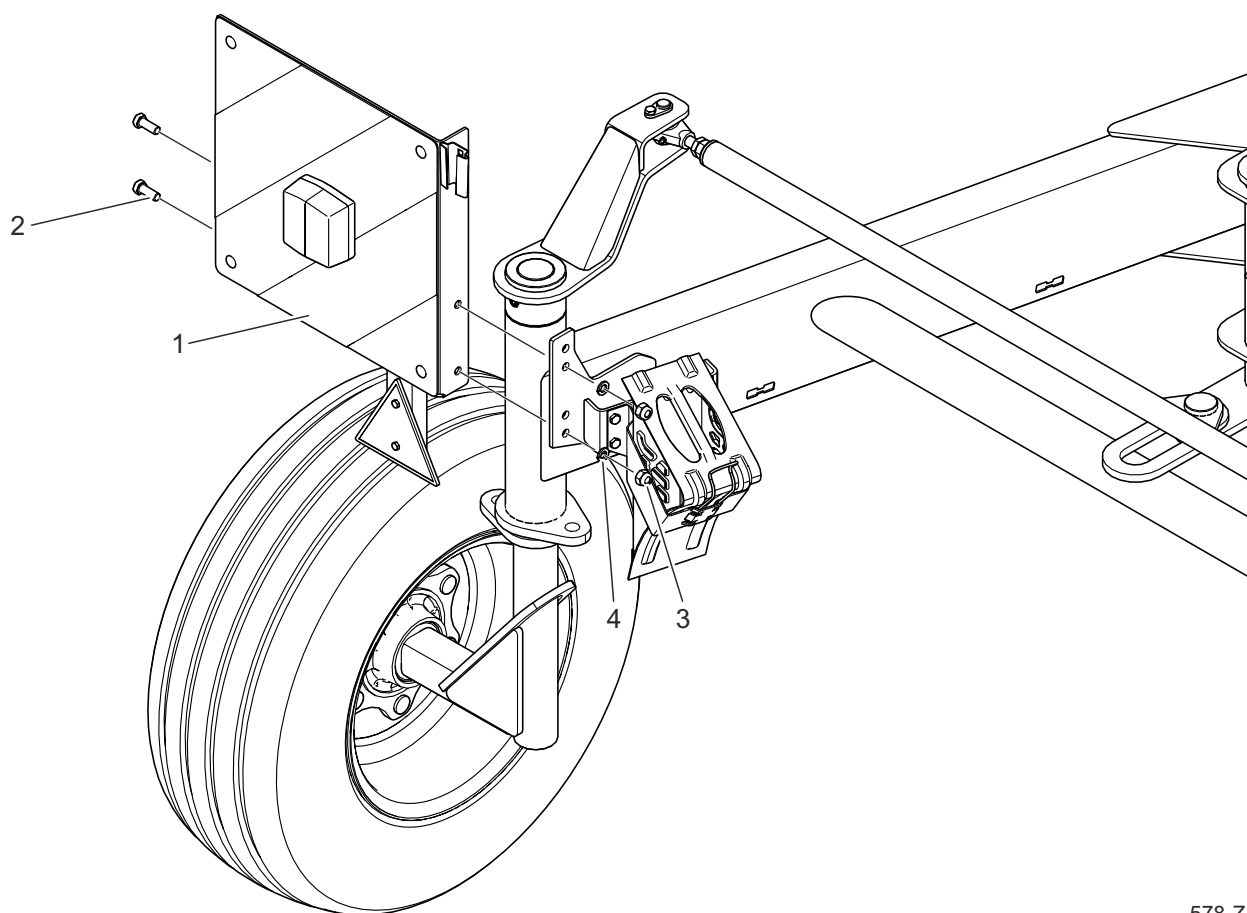

578-Z1.02-1

**Figure A.2** Installing the warning boards

(1) warning board      (2) bolt      (3) self locking nut      (4)- spring washer

For shipment and transport on a motor vehicle, the warning boards are turned and bolted to axle system bracket. Dismantle the boards, turn them outwards by 180° and attach according to figure (A.2).

Z1.1.7.578.03.1.EN

## INSTALLING THE RAKING ASSEMBLIES

Raking assembly should be bolted to the rotary rake arm by means of four bolts (1) – figure (A.3).

After installing the first raking assembly, connect PTO shaft (5) to transmission shaft (6) so that overload safety clutch (8) is located on the raking assembly side.

After connecting the PTO shaft, the rubber shield on the overload safety clutch side



### IMPORTANT

Overload safety clutch of PTO shaft must be located on the raking assembly transmission side. When connecting PTO shafts, make certain that the ends of PTO shaft hitch are securely snapped.

should be secured with a jubilee clip (7).

Repeat the procedure for the second raking assembly.

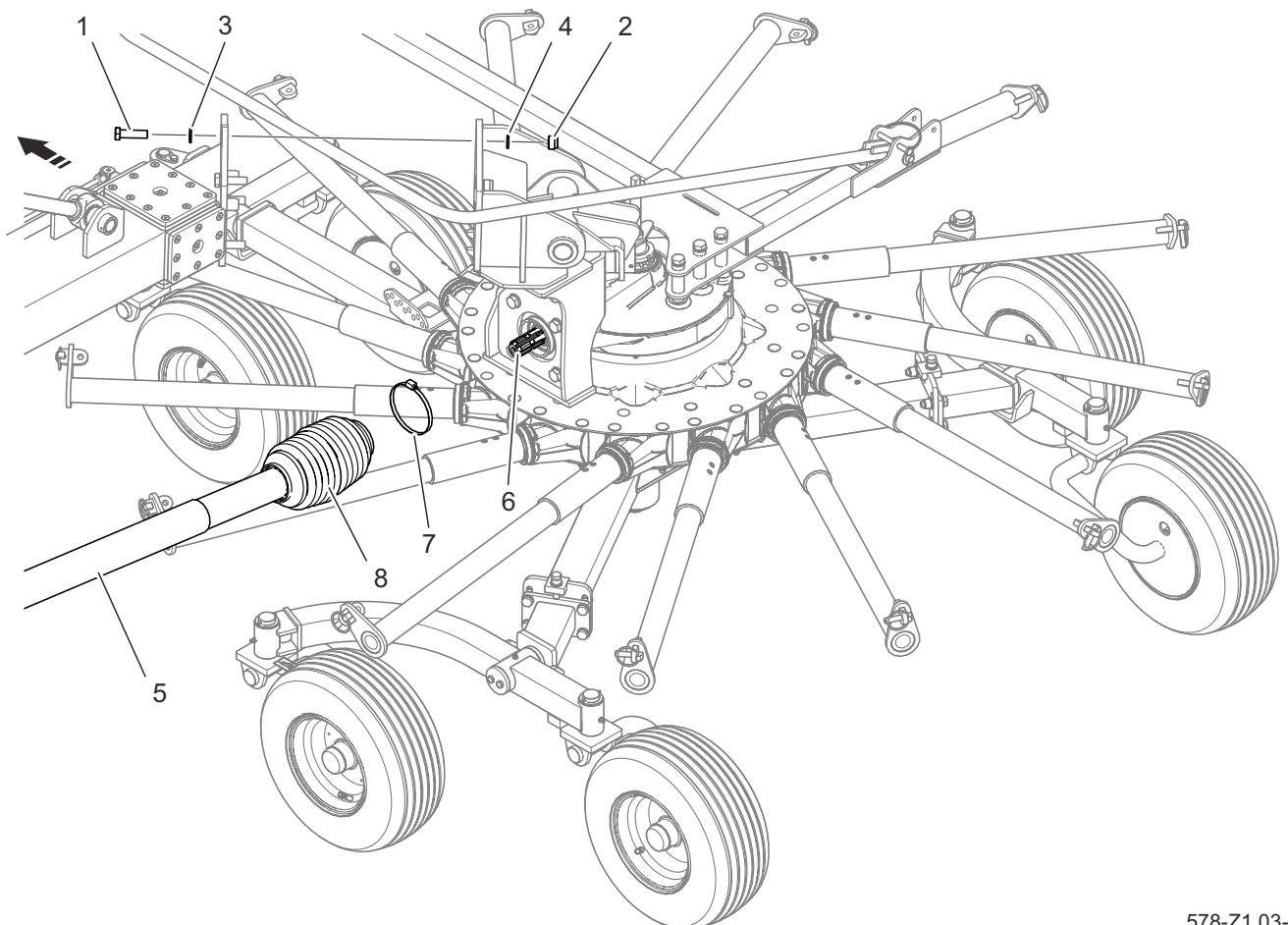

578-Z1.03-1

**Figure A.3** Installing the raking assembly

(1) bolt (2) self locking nut (3) washer (4)- spring washer (5) shaft with overload clutch (6) raking assembly gear shaft (7) band clip (8) overload clutch

Z1.1.7.578.04.1.EN





