



PRONAR Sp. z o.o.

17-210 NAREW, UL. MICKIEWICZA 101A, WOJ. PODLASKIE

tel.:	+48 085 681 63 29	+48 085 681 64 29
	+48 085 681 63 81	+48 085 681 63 82
fax:	+48 085 681 63 83	+48 085 682 71 10

www.pronar.pl

USER MANUAL

FRONT-MOUNTED WRAPPER

Z245/1

TRANSLATION OF THE ORIGINAL COPY OF THE MANUAL

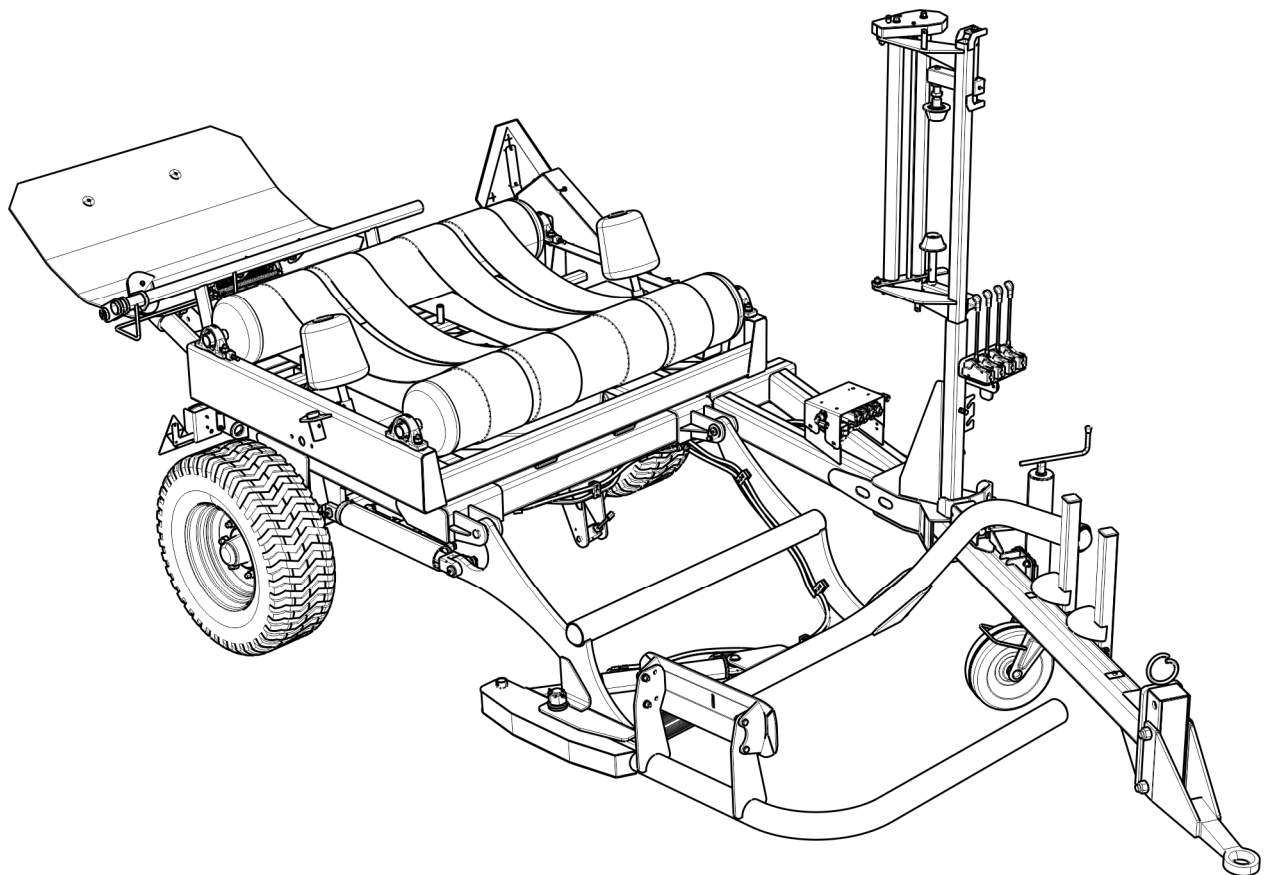

INTRODUCTION

The information contained in the publication is current at the date of publication. As a result of improvement, some sizes and illustrations contained in this publication may not correspond to the actual state of the machine delivered to the user. The manufacturer reserves the right to introduce constructional changes in the manufactured machines to facilitate operation and improve the quality of their work, without making any current changes to this publication.

The operating instruction is the basic equipment of the machine. Before using the machine, the user must read the contents of this manual and observe all recommendations contained therein. This will guarantee safe and trouble-free operation of the machine. The machine was constructed in accordance with applicable standards, documents and current legal regulations. The User Manual describes the basic principles of safe use and operation of the Pronar Z245/1 front-mounted wrapping machine.

If the information contained in the operating instructions does not turn out to be comprehensible, please contact the sales office where the machine was purchased or directly to the Manufacturer.

MANUFACTURER'S ADDRESS

*PRONAR Sp. z o.o.
ul. Mickiewicza 101A
17-210 Narew*

CONTACT PHONE NUMBERS

<i>+48 085 681 63 29</i>	<i>+48 085 681 64 29</i>
<i>+48 085 681 63 81</i>	<i>+48 085 681 63 82</i>

SYMBOLS USED IN THE USER MANUAL

Information, descriptions of hazards and precautions as well as instructions and orders related to safe use in the manual are marked with:



and preceded by the word **DANGER**. Failure to comply with these recommendations may endanger the health or life of persons operating the machine or unauthorized bystanders.

Particularly important information and recommendations, the observance of which is absolutely necessary, are highlighted in the text with a sign:



and preceded by the word **CAUTION**. Failure to comply with these recommendations creates the risk of damage to the machine due to improper handling, adjustment or use.

In order to draw the user's attention to the necessity to perform periodic maintenance, the content of the manual is marked with the following sign:



and preceded by the word **OVERVIEW**

Additional instructions contained in the manual describe useful information on operating the machine and are marked with a sign:



and preceded by the word **ADVICE**.

DESIGNATION OF DIRECTIONS IN THE MANUAL

Left side – the left hand side of the observer facing the machine in the forward direction.

Right side – the right hand side of the observer facing the machine in the forward direction.

THE SCOPE OF SERVICE ACTIVITIES

The maintenance activities described in the manual are marked with the sign: ➡

The result of the maintenance / adjustment activity or remarks concerning the performed activities is marked with the sign: ⇨



PRONAR Sp. z o.o.

ul. Mickiewicza 101 A
17-210 Narew, Polska

tel./fax (+48 85) 681 63 29, 681 63 81, 681 63 82,
681 63 84, 681 64 29

fax (+48 85) 681 63 83

http://www.pronar.pl

e-mail: pronar@pronar.pl

EC DECLARATION OF CONFORMITY OF THE MACHINERY

PRONAR Sp. z o.o. declares with full responsibility, that the machine:

Description and identification of the machinery	
Generic denomination and function:	Bale wrapper
Type:	Z245/1
Model:	—
Serial number:	
Commercial name:	Bale wrapper PRONAR Z245/1

to which this declaration relates, fulfills all the relevant provisions of the Directive **2006/42/EC** of The European Parliament and of The Council of 17 May 2006 on machinery, and amending Directive 95/16/EC (Official Journal of the EU, L 157/24 of 09.06.2006).

The person authorized to compile the technical file is the Head of Research and Development Department at PRONAR Sp. z o.o., 17-210 Narew, ul. Mickiewicza 101A, Poland.

This declaration relates exclusively to the machinery in the state in which it was placed on the market, and excludes components which are added and/or operations carried out subsequently by the final user.

Narew, the 11 CZE. 2013

Place and date

Z-CIA DYREKTORA
d/s. technicznych
czynności zarządu

Roman Omelianiuk

Full name of the empowered person
position, signature

CONTENT

CONTENT	1
CHAPTER	1.1
1 BASIC INFORMATION	1.1
1.1 IDENTIFICATION	1.2
1.1.1 WRAPPER IDENTIFICATION	1.2
1.1.2 DRIVING AXLE IDENTIFICATION	1.4
1.1.3 LIST OF SERIAL NUMBERS	1.5
1.2 INTENDED USE	1.5
1.3 EQUIPMENT	1.7
1.4 TERMS OF WARRANTY	1.9
1.5 TRANSPORT	1.10
1.5.1 TRUCKING	1.10
1.5.2 USER'S TRANSPORT	1.12
1.6 THREAT TO THE ENVIRONMENT	1.12
1.7 WITHDRAWAL FROM USE	1.13
CHAPTER	2.1
2 SAFETY OF USE	2.1
2.1 SAFETY INFORMATION	2
2.1.1 BASIC SAFETY RULES	2
2.1.2 CONNECTING AND DISCONNECTING FROM THE TRACTOR	3
2.1.3 THE HYDRAULIC SYSTEM	4
2.1.4 MAINTENANCE	5

2.1.5	RULES OF TRAVELING ON PUBLIC ROADS	6
2.1.6	TIRES	8
2.1.7	LOADING, UNLOADING, WRAPPING	8
2.2	DESCRIPTION OF RESIDUAL RISK	9
2.3	INFORMATION AND WARNING STICKERS	10

CHAPTER 3.1

3 CONSTRUCTION AND PRINCIPLE OF OPERATION 3.1

3.1	TECHNICAL CHARACTERISTICS	3.2
3.2	WRAPPER DESIGN	3.2
3.2.1	FILM FEEDER	3.4
3.2.2	SWING FRAME, TURNTABLE	3.4
3.2.3	UNLOADING MECHANISM	3.6
3.2.4	CUTTING UNIT	3.8
3.2.5	ELECTRICAL INSTALLATION, WARNING ELEMENTS	3.8
3.2.6	THE HYDRAULIC SYSTEM	3.11

CHAPTER 4.1

4 CONSTRUCTION AND PRINCIPLE OF OPERATION RULES OF USE 4.1

4.1	PREPARATION OF THE WRAPPER FOR WORK	4.2
4.1.1	PRELIMINARY INFORMATION	4.2
4.1.2	CHECKING THE WRAPPER AFTER DELIVERY	4.2
4.1.3	PREPARATION FOR INITIAL START-UP, TEST START OF TRAILER	4.3
4.1.4	PREPARATION OF THE WRAPPER FOR WORK	4.5

4.2	CONNECTING AND DISCONNECTING OF THE WRAPPER TO THE TRACTOR	4.5
4.3	FOIL PLACING	4.9
4.4	FOLDING AND UNFOLDING OF THE DRAWBAR	4.12
4.5	LOADING	4.13
	4.5.1 WRAPPING	4.15
4.6	UNLOADING OF THE BALE	4.19
4.7	DRIVING ON PUBLIC ROADS	4.21
4.8	USE OF TIRES	4.23
4.9	WRAP COUNTER (L01, L02)	4.24
	4.9.1 THE DESIGN AND PRINCIPLE OF THE WRAP COUNTER WORKS	4.24
	4.9.2 OPERATION OF THE COUNTER	4.25
4.10	OPERATION OF COUNTER L01	4.25
	4.10.1 SWITCHING ON AND OFF AND PROGRAMMING OF THE COUNTER	4.25
	4.10.2 WORKING WITH THE COUNTER IN COUNTING MODE	4.26
4.11	OPERATION OF COUNTER L02	4.26
	4.11.1 CONSTRUCTION AND PRINCIPLE OF OPERATION OF THE L02 COUNTER	4.26
	4.11.2 SWITCHING ON AND OFF	4.28
	4.11.3 TO PROGRAM THE WRAPS NUMBER	4.29
	4.11.4 SELECTION OF THE DISPLAY	4.31
	4.11.5 CLEARING OF THE COUNTER	4.32

5 TECHNICAL SUPPORT 5.1

5.1	PRELIMINARY INFORMATION	5.2
5.2	DRIVING AXLE SERVICE	5.2
	5.2.1 PRELIMINARY INFORMATION	5.2
	5.2.2 CHECKING THE CLEARANCE OF THE AXLE BEARINGS	5.3

5.2.3	ADJUSTING THE CLEARANCE OF THE AXLE BEARINGS	5.5
5.2.4	WHEEL ASSEMBLY AND DISASSEMBLY, CHECKING NUT TIGHTNESS	5.6
5.2.5	AIR PRESSURE CONTROL, ASSESSMENT OF TECHNICAL CONDITION OF TIRES AND STEEL WHEELS	5.8
5.3	HYDRAULIC SYSTEM OPERATION	5.9
5.3.1	PRELIMINARY INFORMATION	5.9
5.3.2	CHECKING THE THIGHTNESS OF THE HYDRAULIC SYSTEM	5.9
5.3.3	CHECKING THE TECHNICAL CONDITION OF THE HYDRAULIC CONNECTORS	5.10
5.3.4	REPLACEMENT OF HYDRAULIC HOSES	5.10
5.4	ELECTRICAL SYSTEM SERVICE AND WARNING ELEMENTS	5.11
5.4.1	PRELIMINARY INFORMATION	5.11
5.4.2	REPLACEMENT OF BULBS	5.12
5.5	ADJUSTING OF THE TENSION OF THE TURNTABLE DRIVE CHAIN	5.12
5.6	ADJUSTING OF ROLL DRIVE CHAIN TENSION	5.14
5.7	ADJUSTING OF THE WRAPPER TO THE FOIL 500	5.16
5.7.1	CHANGE THE TRANSMISSION RATIO	5.16
5.8	LOADING ARM BUMPER ADJUSTMENT	5.19
5.9	CHANGING OF THE BALE UNLOADING METHOD	5.20
5.10	ADJUSTING OF THE POSITION OF THE REVOLUTION SENSOR	5.20
5.11	BELTS TENSION ADJUSTMENT	5.22
5.12	WRAPPER LUBRICATION	5.23
5.13	CONSUMABLES	5.27
5.13.1	HYDRAULIC OIL	5.27
5.13.2	LUBRICANTS	5.28
5.14	CLEANING OF THE WRAPPER	5.28

5.15	STORAGE	5.29
5.16	TIGHTENING TORQUE FOR NUT AND BOLT CONNECTIONS	5.30
5.17	ADJUSTING THE POSITION OF THE DRAWBAR	5.32
5.18	FILM TENSION ADJUSTMENT	5.33
5.19	REPLACEMENT AND ADJUSTMENT OF CUTTING KNIVES	5.35
5.20	STORAGE, MAINTENANCE AND REPAIR OF THE WRAP COUNTER	5.37
5.20.1	STORAGE AND CLEANING OF THE COUNTER	5.37
5.20.2	BATTERY REPLACEMENT(COUNTER L01)	5.37
5.21	TROUBLESHOOTING	5.38

APPENDIX A **1**

TIRE ASSEMBLY	1
---------------	---

ATTACHMENT B **B.1**

B.1	CONNECTING THE CONTROL SYSTEM	B.2
B.2	CONTROL PANEL	B.2
B.3	OPERATION OF THE CONTROL PANEL	B.5
B.3.1	STARTING THE CONTROL PANEL	B.5
B.3.2	SWITCHING THE CONTROL PANEL OFF	B.7
B.3.3	EMERGENCY STOPPING OF THE BALE WRAPPER	B.8
B.3.4	OPERATION IN MANUAL MODE	B.9
B.3.5	OPERATION IN SEMI-AUTOMATIC MODE.	B.11
B.3.6	STOPPING AND RESTARTING IN SEMI-AUTOMATIC MODE	B.13
B.3.7	OPERATION IN AUTOMATIC MODE.	B.14
B.3.8	MESSAGES INDICATING COLLISION CONDITIONS	B.15
B.4	SETTING THE BALE WRAPPER'S OPERATING PARAMETERS	B.17

B.4.1	STATISTICAL DATA	B.27
B.4.2	INDICATION OF CURRENT TIME AND DATE	B.28
B.5	SETTING THE BALE WRAPPER FOR TRANSPORT, TRANSPORT MODE	B.29

CHAPTER

1

BASIC INFORMATION

1.1 IDENTIFICATION

1.1.1 WRAPPER IDENTIFICATION

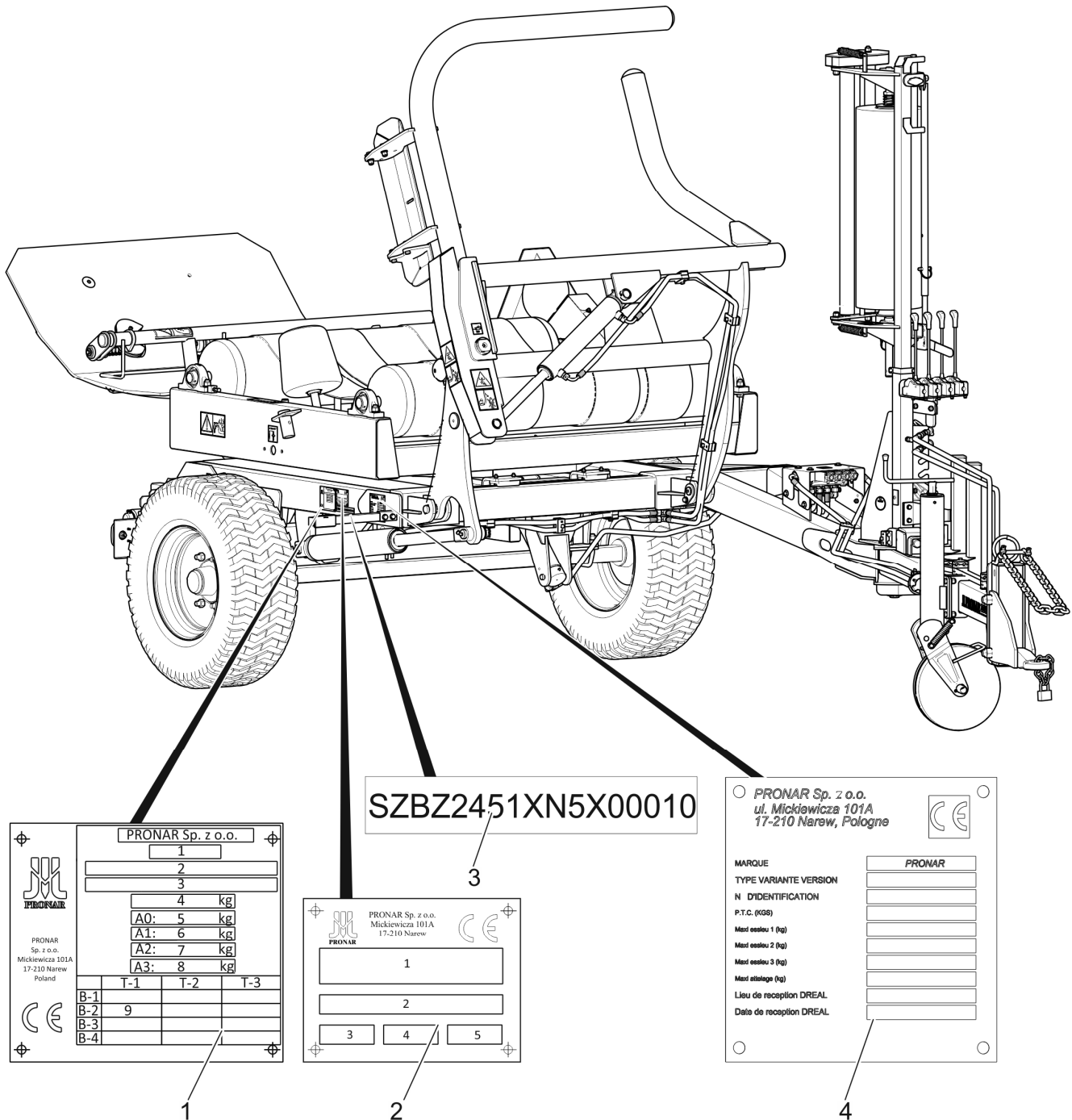

FIGURE 1.1 Location of nameplates and a name number stamping

(1) nameplate, (2) CE nameplate, (3) VIN location, (4) nameplate France

The Pronar Z245/1 wrapper is marked with data plates (1,2,4) and the VIN number (3) placed on a rectangular field painted in gold. The serial number and nameplate are located on the

right frame side member - figure (1.1). When purchasing the machine, check that the serial numbers on the machine match the number entered in the *WARRANTY CARD*, in the sales documents.

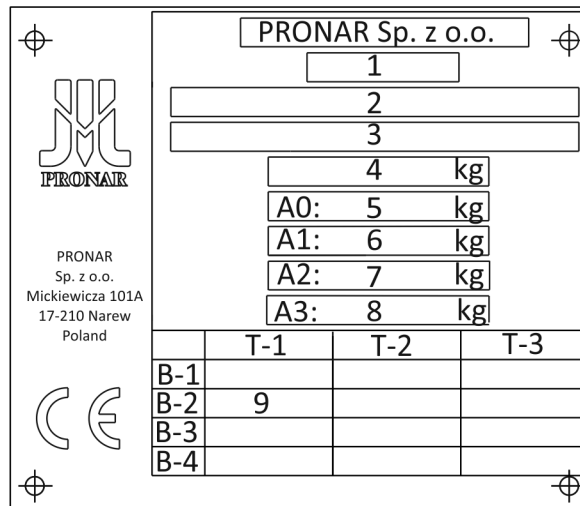

FIGURE 1.2 Nameplate – EU type-approval

(1) Category, subcategory and speed rating of the vehicle; (2) EU approval certificate number; (3) VIN number of the product; (4) Permissible total weight; (5) Drawbar eye load; (6) Maximum permissible weight on axle 1; (7) Maximum permissible weight on axle 2; (8) Maximum permissible weight on axle 3; (9) Technically permissible towable

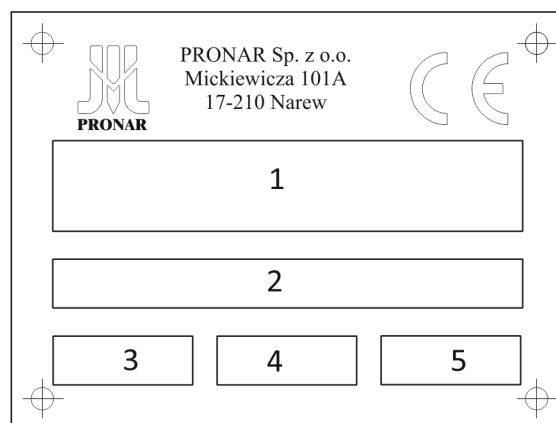

FIGURE 1.3 CE Nameplate

(1) Trade name of the product or general term and function; (2) Product VIN number; (3) Product type (granted in the EU approval process); (4) Year of manufacture; (5) Product model

○ PRONAR Sp. z o.o. ul. Mickiewicza 101A 17-210 Narzew, Pologne		○ 
MARQUE	PRONAR	
TYPE VARIANTE VERSION		
N D'IDENTIFICATION		
P.T.C. (KGS)		
Maxi essieu 1 (kg)		
Maxi essieu 2 (kg)		
Maxi essieu 3 (kg)		
Maxi attelage (kg)		
Lieu de reception DREAL		
Date de reception DREAL		
○		○

FIGURE 1.4 *Nameplate France*

1.1.2 DRIVING AXLE IDENTIFICATION

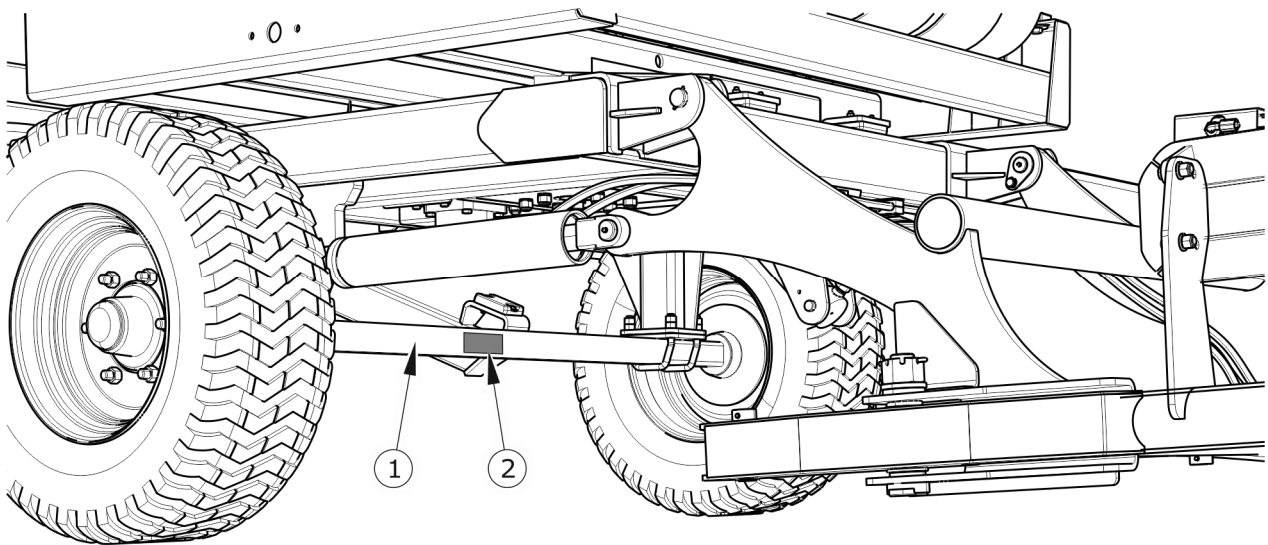

FIGURE 1.5 *Location of the nameplate of driving axle*

(1) nameplate, (2) driving axle

The serial number of the driving axle and its type are stamped on the nameplate (1) attached to the driving axle beam (2) - figure (1.2).

1.1.3 LIST OF SERIAL NUMBERS



ADVICE

If you need to order spare parts or if you have problems with it, it is very often necessary to provide the serial numbers of the part or a number of wrapper, so it is recommended to write these numbers in the fields below.

WRAPPER VIN NUMBER

--	--	--	--	--	--	--	--	--	--	--	--	--	--	--	--	--	--

AXES SERIAL NUMBER

--	--	--	--	--	--	--	--	--	--	--	--	--	--

1.2 INTENDED USE



CAUTION

The wrapper may not be used for purposes other than those for which it was intended.

The hydraulic engine is equipped with a system protecting the wrapper drive against overload. It is forbidden to adjust the factory settings of the engine.

The wrapper is designed to wrap round bales of feed with a stretchable film width of 500 or 750 mm. Rolls of crop material formed by roll presses must not exceed 1 250 mm in width and must not exceed 1 500 mm in diameter. The maximum permissible gross weight of the bale is 1 000 kilograms.

The machine is suitable for use with agricultural tractors equipped with a hydraulic external system having free hydraulic oil drain to the tank without throttling the flow.

The wrapper was constructed in accordance with applicable safety requirements and machine standards. The speed of the wrapper travelling on public roads is 30 km/h. During operation (wrapping), the maximum speed of the set must not exceed 5 km/h, provided that the passage is made on flat level ground.

Intended use also includes all activities related to the correct and safe operation and maintenance of the machine. Therefore, the user is obliged to:

- Read the content of the wrapper's *USER MANUAL* and with *WARRANTY CARD* and to the guidelines contained in these documents,
- understand the principle of machine operation and the safe and proper operation of the wrapper,
- work in compliance with established maintenance and adjustment plans,
- work in compliance with general safety regulations,
- accident prevention,
- comply with road traffic regulations in force in the country in which the wrapper is used,
- get acquainted with the contents of the farm tractor instruction manual and comply with its recommendations,
- couple the machine only with such an agricultural tractor that meets all the requirements set by the wrapper Manufacturer.

The wrapper may only be used by persons who:

- become familiar with the contents of publications and documents attached to the machine and the contents of manual agricultural tractor,
- have been trained in wrapper operation and work safety,
- they have the required authorisations to drive the vehicle.

TABLE 1.1 *Agricultural tractor requirements*

Content	Unit	Requirements
The hydraulic system		
Hydraulic oil	-	L HL 32 Lotos
Nominal pressure of the system	bar / MPa	150 / 15
Oil demand	l	5.6
Hydraulic sockets	-	in accordance with ISO - 7421- 1 return socket with free oil drain (so-called "free sink")
Electrical system		
Electrical system voltage	V	12
Connection socket	-	7 poles in accordance with ISO 1724
Tractor hitch required		
Type	-	Hitch for single-axle trailers Upper transport hitch
Other requirements		
Minimum power	kW / KM	35 / 48

1.3 EQUIPMENT

TABLE 1.2 *Equipment*

Equipment	STANDARD	OPTIONAL	ADDITIONAL
User manual	✓		
Warranty Card	✓		
Electronic wrap counter L01 + counter manual	✓		

Equipment	STANDARD	OPTIONAL	ADDITIONAL
Electronic wrap counter L02 + counter manual		✓	
Plate for slow-moving vehicles		✓	
Roller chain (12B-1/9-WZ) with connection link – 85 links	✓		
Sprocket Z28	✓		
Mounting bracket (to be installed in the tractor cab)	✓		
Roller chain (12B-1/9-WZ) with connection link – 85 links			✓
Link roller chain extension – 9 links	✓		
Sprocket Z45			✓
Ø40 fixed tie rod	✓		
Rotary tie rod Ø50		✓	
Ø50 fixed tie rod		✓	
Plate for slow-moving vehicles			✓
Safety chain set			✓

(1) standard, (2) additional, (3) optional



ADVICE

The tire information is given at the end of the instructions in APPENDIX A.

The wrapper is factory-adapted to work with a 750 mm wide film with a mounted Z28 sprocket and a chain with 85 links and a connecting link.

1.4 TERMS OF WARRANTY



ADVICE

You should require the seller to carefully fill out the Warranty Card and complaint coupons. The lack of e.g., date of sale or point of sale stamp exposes the user to not accept any complaints.

PRONAR Sp. z o.o. in Narew guarantees smooth operation of the machine when it is used in accordance with the technical and operational conditions described in the USER MANUAL. Deadline for completion of repairs is specified in the Warranty Card.

- The warranty does not apply to parts and sub-assemblies of the machine, which are subject to wear in normal operating conditions, regardless of the warranty period.

The warranty services only apply to such cases as: mechanical damage not caused by the fault of the user, factory defects of parts, etc.

In the event that damage occurs as a result of:

- mechanical damage caused by the user's fault, road accident,
- from improper operation, adjustment and maintenance, using the wrapper contrary to its purpose,
- use of a damaged machine,
- repairs carried out by unauthorized persons, improper repairs,
- execution of user changes in machine design,
- the user loses the warranty.

The user is obliged to immediately report all noticed defects in the paint coatings or traces of corrosion, and order removal of defects regardless of whether the damage is covered by the warranty or not. Detailed warranty conditions are given in the *WARRANTY CARD* attached to the newly purchased machine.

Modifications to the wrapper without the written consent of the Manufacturer are prohibited. In particular, welding, reaming, cutting and heating of the main machine components that directly affect safety during use are not permitted.

1.5 TRANSPORT

The wrapper is ready for sale completely assembled and does not require packing. Only the technical and operational documentation of the machine, and possibly elements of additional and standard equipment, are packed. Delivery to the user is carried out by road or independent transport (towing of the wrapper with an agricultural tractor).

1.5.1 TRUCKING

Loading and unloading of a wrapper from a car should be carried out using a loading ramp using a farm tractor, lever of lift. During work act in compliance with the general principles of workplace health and safety for reloading work. Persons operating reloading equipment must have the required permissions to use these devices.

The wrapper should be attached firmly to the platform of the vehicle using straps, chains, lashings or other fastening devices equipped with a tensioning mechanism. Fastening elements should be attached to transport handles (1) - figure (1.3), marked with stickers (2) or to permanent structural elements of the wrapper (string members, crossbars, etc.). Transport handles are welded to the frame longitudinal members (2), one pair on each side of the machine.



CAUTION

During road transport, the wrapper must be mounted on the platform of the vehicle in accordance with safety requirements and regulations.

While driving, the car driver should exercise extreme caution. This is due to the vehicle's centre of gravity shifting upwards with the machine loaded.

Use only approved and technically reliable securing measures. Read the operating instructions of the securing measures manufacturer.

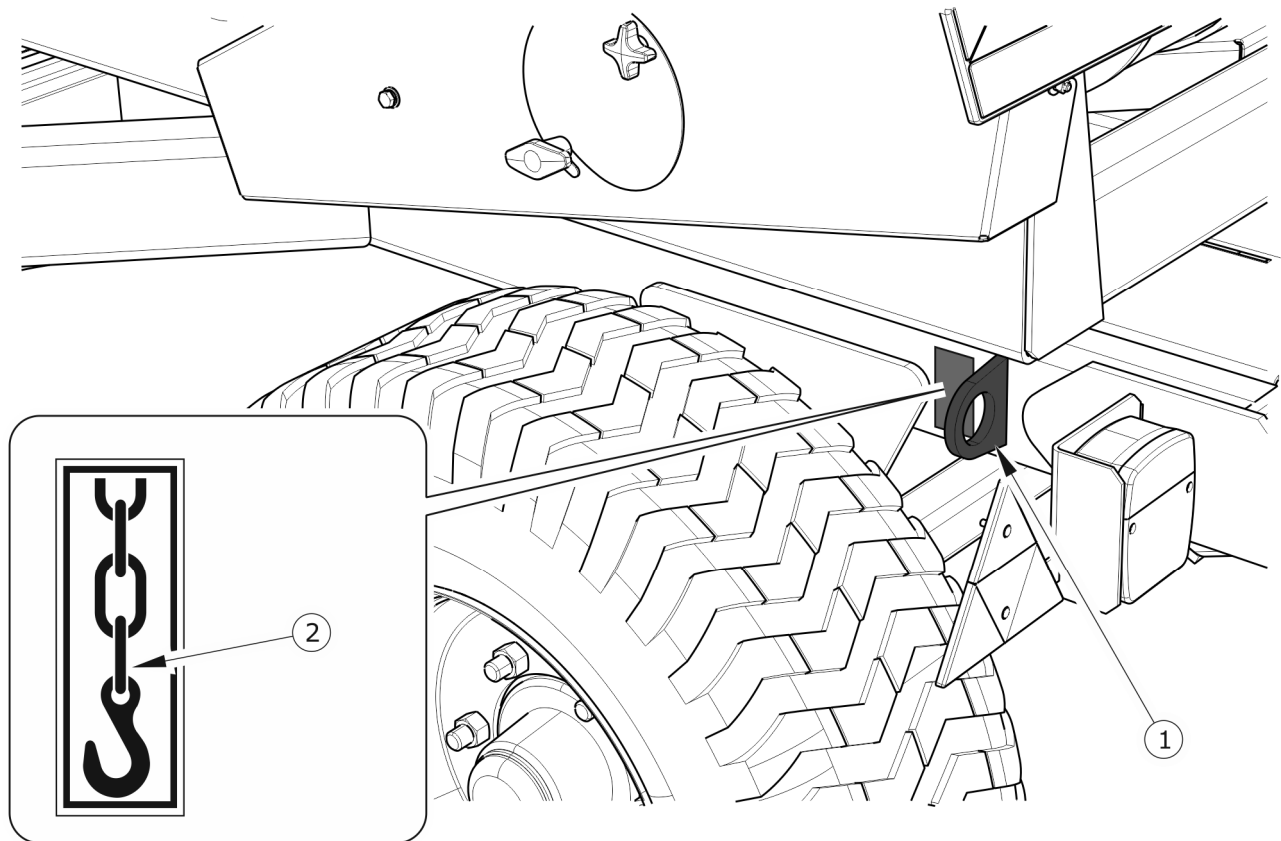

FIGURE 1.6 Arrangement of transport handles

(1) transport handle, (2) information sticker

Use certified and technically reliable securing measures. Wiping belts, cracked fasteners, bent or corroded hooks or other damage may disqualify the product from being used. Please refer to the instructions in the operating instructions of the manufacturer of the securing material used. Chocks, wooden beams or other elements without sharp edges should be placed under the wrapper wheels, protecting the machine against rolling. wheel blocks must be nailed to the load platform planks of the car or secured in another way preventing their movement. The number of fastening elements (ropes, belts, chains, lashings, etc.) and the force needed for their tension depends, among others, on the weight of the wrapper, the construction of the car carrying the wrapper, the speed of travel and other conditions. Therefore, it is not possible to specify the fastening plan in detail. A properly attached machine will not change its position relative to the transporting vehicle. The fastening means must be selected according to the manufacturer's instructions. In case of doubt, a larger number of attachment and securing points for the wrapper should be used. If necessary, the sharp edges of the machine must be protected to protect the fastening means against damage during transport.

**DANGER**

Incorrect use of securing measures can cause an accident.

During reloading work, particular attention should be paid so as not to damage the machine equipment components and the paint coating. The weight of the wrapper is given in table (3.1).

1.5.2 USER'S TRANSPORT

In the case of independent transport by the user, read the Operating Manual and follow its recommendations. Independent transport involves towing a wrapper with own agricultural tractor to its destination. While driving, adjust the speed to the prevailing road conditions, but it must not be greater than the maximum design speed.

**CAUTION**

When transporting independently, the tractor operator should read the instructions and follow the recommendations contained therein.

1.6 THREAT TO THE ENVIRONMENT

A hydraulic oil leak is a direct threat to the natural environment owing to its limited biodegradability. The negligible water solubility of the hydraulic oil does not cause acute toxicity of organisms living in the aquatic environment. The resulting oil layer on the water can be the cause of direct physical hazards for organisms, it can cause changes in the oxygen content in the water due to the lack of direct contact between air and water. An oil leak into water reservoirs can, however, lead to a reduction in oxygen content.

**DANGER**

Used hydraulic oil or collected residues mixed with absorbent material should be stored in a precisely marked container. Do not use food packaging for this purpose.

When carrying out maintenance and repair work where there is a risk of leakage, this work should be carried out in rooms with an oil resistant surface. In the event of oil leaking into the environment, first of all contain the source of the leak, and then collect the leaked oil using available means. Collect oil residue with sorbents or mix the oil with sand, sawdust or other absorbent materials. Collected oil contaminants should be stored in an airtight and marked container, resistant to hydrocarbons. The container should be kept away from heat sources, flammable materials and food.

Oil which has been used up or is unsuitable for further use due to the loss of its properties is recommended to be stored in its original packaging in the same conditions as described previously. Oil waste should be taken to an oil disposal or regeneration point. Waste Code: 13 01 10. Detailed information on hydraulic oil can be found in the product safety data sheet.

**ADVICE**

The wrapper's hydraulic system is filled with L-HL 32 Lotos oil.

**CAUTION**

Oil waste can only be delivered to a point dealing with the utilization or regeneration of oils. It is prohibited to throw or pour oil into the sewage system or water reservoirs.

1.7 WITHDRAWAL FROM USE

If the user decides to withdraw the wrapper from use, comply with the provisions in force in the given country regarding withdrawal from use and recycling of machines withdrawn from use. Before dismantling the wrapper, the oil must be completely from the hydraulic system.

**DANGER**

During dismantling, use appropriate tools and equipment (overhead cranes, elevators, lifts, etc.) and use personal protective equipment, i.e., protective clothing, footwear, gloves, glasses, etc.

Worn or damaged parts that cannot be regenerated or repaired should be sent to a recycling centre. Hydraulic oil should be taken to the appropriate facility dealing with the utilization of this type of waste.

**DANGER**

Avoid oil contact with skin. Do not allow hydraulic oil to leak.

TABLE 1.3 *The codes for the waste arising from disassembly*

ITEM	CODE	MEANING
1	07 02 13	Plastic waste
2	13 01 10	Other hydraulic oils
3	13 02 04*	Mineral engine, transmission and lubricating oils containing organochlorines
4	13 02 06*	Synthetic engine, transmission and lubricating oils
5	13 02 08*	Other engine, transmission and lubricating oils
6	13 05 02*	Sludges from oil drainage in separators
7	13 05 08*	A mixture of wastes from sandblasting and oil drainage in separators
8	15 01 10*	Packaging containing or contaminated with residues of dangerous substances
9	15 02 02*	Sorbents, filter materials and protective clothing contaminated with hazardous substances
10	16 01 03	Worn tires
11	16 01 18	Ferrous metals
12	16 01 22	Other items not listed

CHAPTER

2

SAFETY OF USE

2.1 SAFETY INFORMATION

2.1.1 BASIC SAFETY RULES

- Before using the wrapper, the user should carefully read this User Manual and the manual attached to the electronic rev counter. During their operation, all recommendations contained therein must be observed. Do not start the wrapper without knowing its functions.
- The user is obliged to become familiar with the construction, operation and principles of safe machine operation.
- Before each start-up of the wrapper, make sure that it is prepared for the work, especially for safety.
- If the information contained in the User's Manual is difficult to understand, contact a seller who runs an authorized technical service on behalf of the manufacturer, or contact the manufacturer directly.
- Access to the wrapper is only possible when the machine is absolutely stationary, the tractor engine is switched off and the ignition key is removed.
- Careless and improper use of the wrapper, well as non-compliance with the recommendations contained in this manual puts the health and life of unauthorized persons and/or the machine operator at risk.
- The wrapper may only be used when all the covers and other protective elements are functional and located on proper place.
- It should be remembered that there is a residual risk of hazard, therefore the application of the rules of safe use should be the basic principle of using the wrapper.
- The wrapper must not be used by persons who are not authorized to drive agricultural tractors, including children and people under the influence of alcohol or other drugs.
- The wrapper may not be used for purposes other than those for which it was intended. Everyone who uses the machine in a manner contrary to its intended use, thus takes full responsibility for all consequences arising from its use. Using the machine for purposes other than intended by the Manufacturer is treated as use not intended for the machine and may invalidate the warranty.

- Any modification of the wrapper is prohibited and exempts PRONAR Narew liability for any damage or injury.
- Before each use of the machine, check the condition of the machine, in particular the condition of the drawbar, the hydraulic system, the safety guards and the tire pressure.
- The wrapper's maximum carrying capacity must not be exceeded.
- Do not exceed the maximum rotation of the rotary table.
- Never carry bales or any load on the wrapper during a transport trip.
- Never exceed the permissible transport speed of the unit.

2.1.2 CONNECTING AND DISCONNECTING FROM THE TRACTOR

- Take special care when connecting the machine.
- Before connecting the machine, remove the safety device from the drawbar tie rod.
- Use a suitable tractor hitch when tying the wrapper. After coupling the machines, check the hitch safety device. Read the tractor operating instructions. If the tractor is equipped with an automatic hitch, make sure that the coupling operation has been completed.
- When coupling, there must be nobody between the tractor and the wrapper.
- Do not connect the wrapper to the tractor if it does not meet the manufacturer's requirements. Before connecting the wrapper, make sure that the oil in the tractor's external hydraulic system can be mixed with the machine's hydraulic oil.
- When connecting the hydraulic conduits to the tractor, make sure that the tractor hydraulic system and wrapper are not under pressure. If necessary, reduce the residual pressure of the system.
- Before coupling the wrapper make sure that both machines are technically sound.
- When the machine is disconnected from the tractor, it must be on level ground and supported by a support. The ends of the hydraulic and electrical lines should be protected from contamination.
- When you have finished disconnecting the machine, protect the machine from unauthorized use.
- There is a risk that the support wheel may fold when the wrapper is moved when the wrapper is disconnected. Take special care.

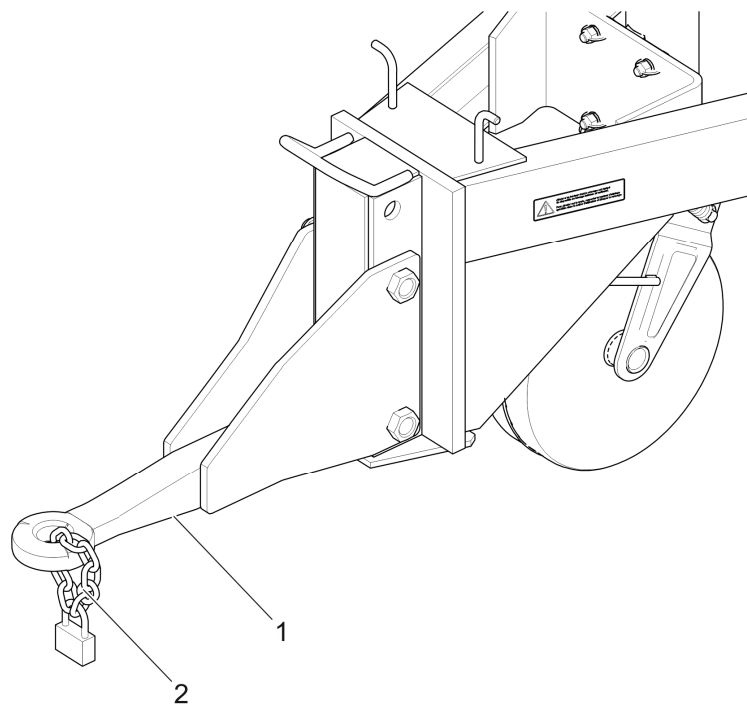

FIGURE 2.1 *Mounting location for the slow-moving vehicle sign*

(1) drawbar eye, (2) securing the eye against unauthorized use

2.1.3 THE HYDRAULIC SYSTEM

- The hydraulic system is under high pressure during operation of the wrapper.
- Regularly check the condition of connections and hydraulic hoses. Hydraulic oil leaks are not allowed.
- In the event of failure of the hydraulic system, the wrapper must be decommissioned until the failure is remedied.
- Ensure that the hydraulic system is not pressurized before performing maintenance and repair work.
- Rubber hydraulic conduits must be replaced every 4 years regardless of their technical condition.
- Use hydraulic oil recommended by the manufacturer.
- After changing the hydraulic oil, the used oil must be disposed. Used oil or oil which has lost its properties should be stored in original containers or replacement packaging resistant to hydrocarbons. Replacement containers must be accurately described and properly stored.
- It is forbidden to store hydraulic oil in packaging intended for food storage.

2.1.4 MAINTENANCE

- Never carry out service or repair work with the hydraulic motor drive engaged. Stop the tractor engine and remove the ignition key before starting work. If necessary, secure the wrapper against rolling by placing locking wedges under the wheels.
- Regularly check the condition of the screw connections.
- During the warranty period, any repairs may only be carried out by a Warranty Service authorized by the manufacturer. After the end of the warranty period, it is recommended that any repairs to the wrapper be carried out by specialized workshops.
- During maintenance work, use appropriate, close-fitting protective clothing, gloves, shoes, glasses and the right tools.
- In the event of any faults or damage, the wrapper should be decommissioned until repaired.
- Perform maintenance and repair activities applying general principles of health and safety at work. In the event of a cut, the wound should be immediately washed and disinfected. In case of serious injuries consult a physician.
- Inspect the wrapper according to the frequency specified in this manual.
- It must be unloaded before starting work that requires lifting the turntable. Secure the table against falling with a folding support. During this time, the wrapper must be connected to the tractor and secured with wedges.
- Before welding or electrical work, the wrapper should be disconnected from the power supply. The paint coating should be cleaned. The fumes of burning paint are poisonous to humans and animals. Welding work should be carried out in a well-lit and ventilated room.
- During welding work, pay attention to flammable or fusible elements (elements of electrical and hydraulic installations, elements made of plastic and rubber). If there is a risk of ignition or damage, they must be removed or covered with non-flammable material before welding. Before starting work, it is recommended to prepare a CO₂ or foam extinguisher.
- In the event of work requiring the wrapper to be raised, use properly certified hydraulic or mechanical lifts for this purpose. After lifting the machine, stable and durable

supports must also be used. It is forbidden to work under a wrapper raised only with a lift.

- It is forbidden to support the wrapper with fragile elements (bricks, hollow bricks, concrete blocks).
- After completing work associated with lubrication, remove excess grease or oil. The wrapper should be kept clean.
- Be careful when climbing onto the wrapper. The machine must be secured against rolling by wedges.
- Do not attempt to repair the hydraulic valves, the distributor or the cylinders yourself. In case of damage to these elements, the repair should be entrusted to authorized repair centres or replace the elements with new ones.
- It is forbidden to repair the drawbar (straightening, surfacing, welding). A damaged drawbar must be replaced.
- It is forbidden to install additional devices or accessories that do not comply with the specification specified by the Manufacturer.
- It is allowed to tow the wrapper only if the running gear and lighting system are in good working order.
- Check the condition of protective elements, their technical condition, correct fastening.
- If it is necessary to replace individual parts, use only original parts or those indicated by the Manufacturer. Failure to comply with these requirements may pose a threat to the health of bystanders or persons operating the wrapper, as well as contribute to damage to the machine.
- In the event of injuries being caused by pressurized hydraulic oil, contact a doctor immediately. Hydraulic oil can penetrate the skin and cause infection. If the oil gets into the eyes, rinse with plenty of water and if irritation occurs, contact a doctor. In the event of contact of oil with skin, wash the area of contact with water and soap. Do not use organic solvents (petrol, kerosene).

2.1.5 RULES OF TRAVELING ON PUBLIC ROADS

- During a transport trip, adjust the ground speed to the ambient conditions. If possible, avoid driving over uneven terrain and unexpected turns.

- When driving on public roads, comply with traffic regulations.
- Do not exceed the maximum speed resulting from restrictions on road conditions and design restrictions.
- During periods of insufficient visibility, a red light and a red reflector must be placed on the rearmost edge of the wrapper.
- After the wrapper has been prepared for passage, a triangular marking plate for slow moving vehicles must be placed on the cutter covers, Figure (2.1).
- Reckless driving and excessive speed can cause an accident.
- Before driving, make sure that the wrapper is correctly connected to the tractor (in particular check the safety of the hitch pin).

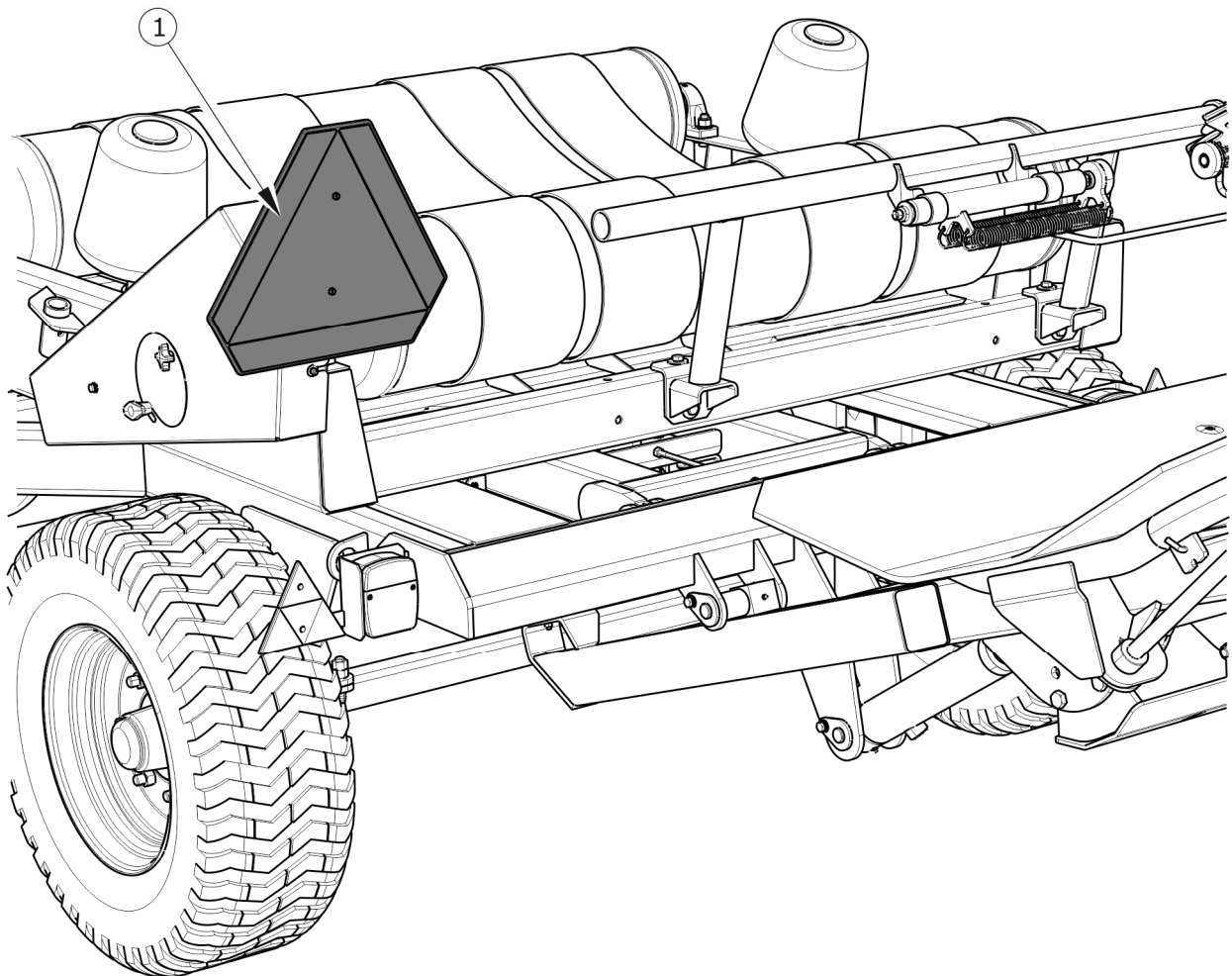

FIGURE 2.2 *Mounting location for the slow-moving vehicle sign*

(1) distinguishing sign

- Vertical load carried by the wrapper drawbar eye affects the steering of the agricultural tractor.

- It is forbidden to get on the wrapper while driving.
- Parking the wrapper on a decline is prohibited.
- It is forbidden to leave the machine unsecured. The wrapper must be blocked with the secured against rolling with wedges or other elements without sharp edges placed under the vehicle wheels. The load arm must be lowered.

2.1.6 TIRES

- When working with tires, the wrapper should be secured against rolling by placing chocks under the wheels. The wheel can be dismantled only when the wrapper is not loaded.
- Repair work on wheels or tires should be carried out by persons trained and authorized to do so. These works should be carried out using appropriately selected tools.
- Nut tightness should be checked after the wrapper is used for the first time, after the first journey with a load and then every 6 months of use or every 25,000 kilometres, whichever comes first. In the event of intensive work, check the nut tightening at least every 10,000 kilometres. Each time, the inspection activities should be repeated if the wrapper wheel has been disassembled.
- Avoid damaged road surfaces, sudden and variable manoeuvres, and high speeds when turning.
- Check tire pressure regularly. Tire pressure should also be checked during all-day intensive work. It should be taken into account that an increase in tire temperature can increase the pressure by up to 1 bar. With such a rise in temperature and pressure, reduce the load or speed. Never reduce pressure by venting if it increases due to temperature.
- Tire valves should be protected with suitable caps to avoid penetration of dirt.

2.1.7 LOADING, UNLOADING, WRAPPING

- Make sure that the load arm lock is removed before loading.
- The wrapper's maximum carrying capacity must not be exceeded.
- Do not wrap bales other than those specified in this manual.
- Ensure that the wrapper and the danger zone are clearly visible before starting work.

- Before wrapping a bale, make sure that there are no bystanders or obstructions near the rotating area of the screed that will prevent the machine from operating properly. Lower the load arm.
- The wrapper should stand firmly on level ground during operation. It is not permitted to operate the machine on slopes.
- The bale must only be loaded on the rotary table when the wrapper is stopped.
- It is permitted to wrap the bale while driving only when the vehicle is travelling on level ground. Do not exceed the permitted ground speed during operation.
- Adjust the rotary table speed to suit the size and weight of the bales to be wrapped. Do not exceed the maximum rotational speed.
- During unloading, care must be taken to ensure that the bale does not overwhelm bystanders.
- Unloading and loading of the wrapper can only be carried out when the machine is on level and hard ground and connected to the tractor. The tractor and the wrapper must be in the straight-ahead position.
- During loading and unloading of the wrapper and during wrapping of the bale, the tow bar and the tractor hitch are subjected to heavy vertical load.
- Driving with the turntable raised is prohibited.

2.2 DESCRIPTION OF RESIDUAL RISK

Pronar Sp. z o. o. in Narew made every effort to eliminate the risk of an accident. However, there is some residual risk that can lead to an accident and is primarily associated with the following activities:

- Using the wrapper for purposes other than described in the manual,
- being between the tractor and the wrapper when the engine is running and when connecting the machine,
- being on the machine during engine work,
- operation of the wrapper with the covers removed or inoperative,
- failure to maintain a safe distance during wrapper operation,
- failure to maintain a safe distance during unloading operations

- operation of the wrapper by unauthorized persons or persons under the influence of alcohol
- wrapper cleaning, maintenance and technical inspection,
- operating the machine on unstable and sloping ground
- introducing design changes without the consent of the Manufacturer,
- presence of persons or animals in areas invisible from the operator's position.

Residual risk can be reduced to a minimum by following these recommendations:





- prudent and leisurely machine operation,
- maintaining a safe distance from prohibited or dangerous places during unloading, loading, wrapping and coupling the wrapper,
- sensible application of the remarks and recommendations contained in the operating instructions,
- carrying out maintenance repair work in accordance with operating safety rules, carrying out maintenance repair work by trained persons,
- the use of close-fitting protective clothing and appropriate tools,
- Securing the machine against access by unauthorized persons, especially children,
- keeping a safe distance from prohibited and dangerous places,
- a ban on being on the machine while driving, loading, unloading, wrapping.





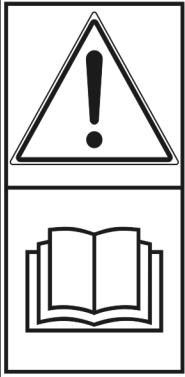
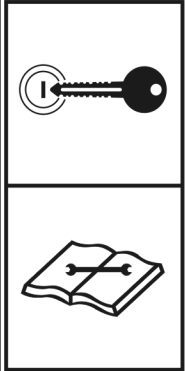

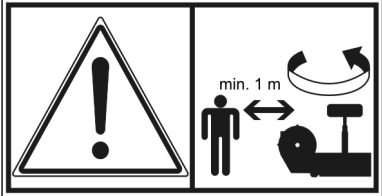
2.3 INFORMATION AND WARNING STICKERS



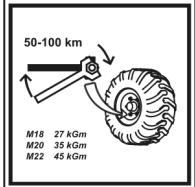

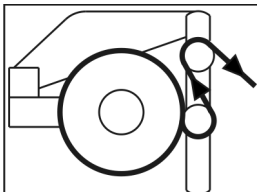
The wrapper is marked with information and warning decals mentioned in table (2.1). The arrangement of symbols is shown in figure (2.3) and (2.4). The machine user is obliged to ensure that the inscriptions, warning and information symbols placed on the wrapper are legible throughout the entire period of use. In the event of their destruction, they must be replaced.

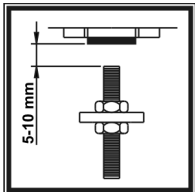
TABLE 2.1 *INFORMATION AND WARNING Stickers*

Item	Sticker	DESCRIPTION
1		Wrapper type. 382N-00000003

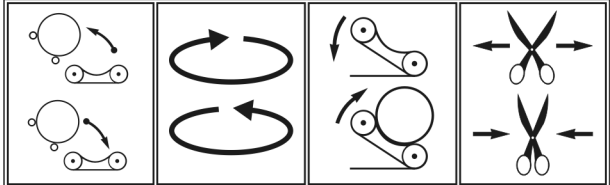
Item	Sticker	DESCRIPTION
2		<p>Caution.</p> <p>Before starting work, read the User's Manual.</p> <p>70RPN-00.00.00.04</p>
3		<p>Before starting any servicing or repair work, switch off the tractor engine and remove the ignition key. Secure the tractor cab against unauthorized access.</p> <p>70RPN-00.00.00.05</p>
4		<p>Risk of injury to limbs.</p> <p>Do not reach into the cutting knives area.</p> <p>119RPN-00.00.00.06</p>
5		<p>Caution.</p> <p>Keep at least 1 meter away from the wrapper as the table rotates.</p> <p>119RPN-00.00.00.05</p>
6		<p>Danger of being crushed.</p> <p>124RPN-00.00.00.07</p>

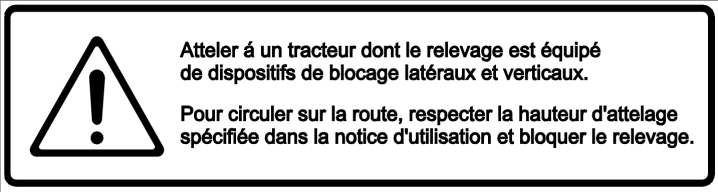
Item	Sticker	DESCRIPTION
7		<p>Do not sit near the raised loading arm or the raised discharge frame.</p> <p>124RPN-00.00.00.08</p>
8		<p>Regularly check the tightness of wheel nuts and other bolted connections.</p> <p>104RPN-00.00.00.06</p>
9		<p>Lubricate the wrapper according to the schedule outlined in the User's Manual.</p> <p>104RPN-00.00.00.04</p>
10		<p>Number of lubrication points.</p> <p>70RPN-00.00.00.22</p>
11		<p>How to install the wrapping film.</p> <p>119RPN-00.00.00.08</p>
12		<p>Distinguishing sticker. Contour marking.</p> <p>119RPN-00.00.00.10</p>
13		<p>Sensor adjustment information.</p> <p>119RPN-00.00.00.12</p>
14		<p>Marking of transport handles.</p> <p>58RPN-00.00.019</p>
15		<p>Turntable rotation direction.</p> <p>119RPN-00.00.00.07</p>

Item	Sticker	DESCRIPTION
16		Direction of hydraulic oil flow in the connection line. 70RPN-00.00.00.21
17		Hydraulic distributor function information label. 124RPN-00.00.00.05
18		Unloading mechanism lowering speed control. 124RPN-00.00.00.09
19		Caution Information on how to couple the machine to the tractor (for French approval)
20		Maximum speed 25 km/h information label (for French approval)

Labels with inscriptions and symbols are available from the Manufacturer or in the place where the machine was purchased. The catalogue numbers of the information stickers can be found under the pictogram description in the table (2.1) and in the SPARE PARTS CATALOG. New assemblies replaced during repair must be marked again with the appropriate safety signs. When cleaning the wrapper, do not must use solvents that may damage the label coating and do not direct a strong water jet.

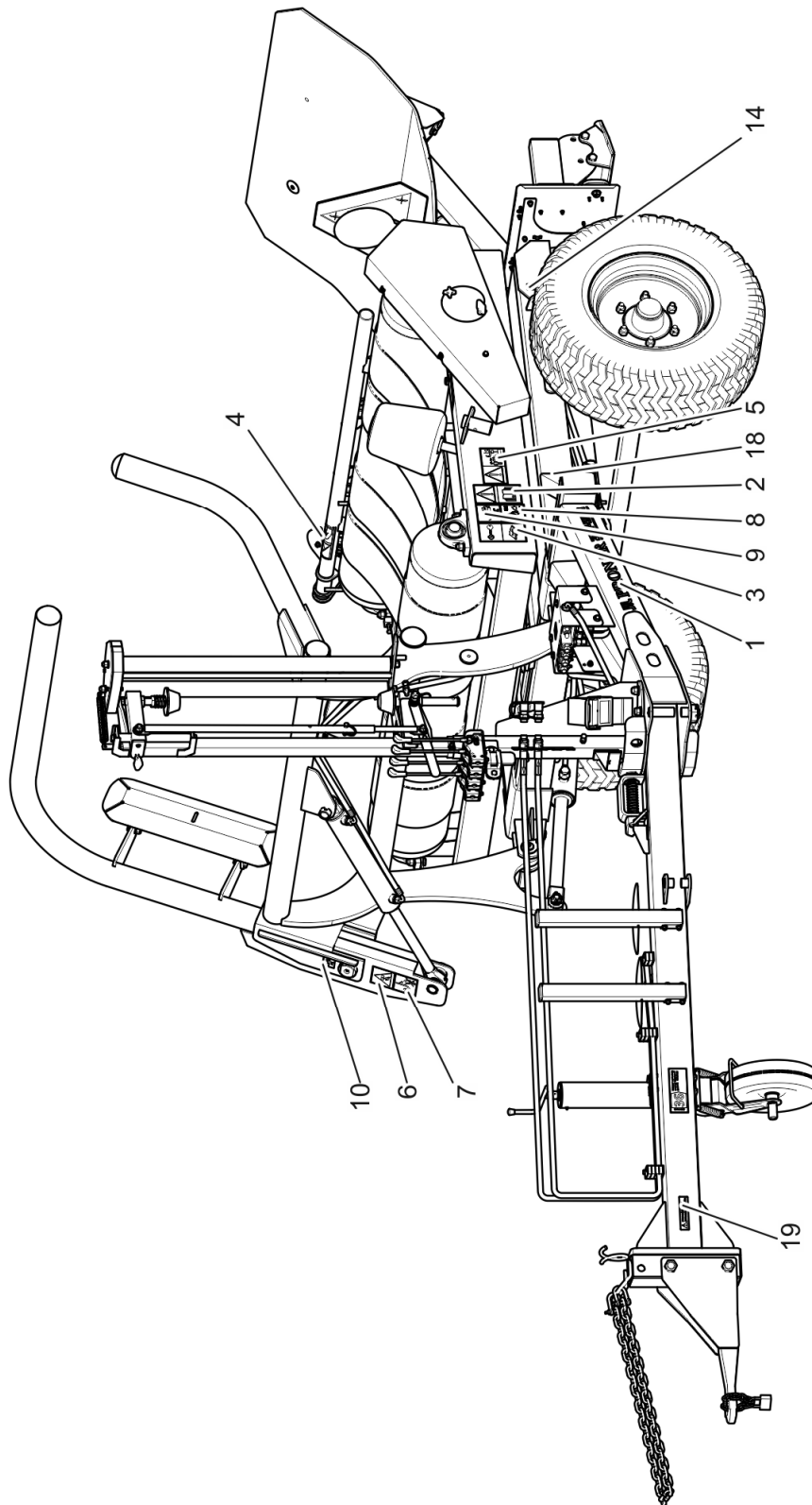

FIGURE 2.3 *Arrangement of information and warning stickers, part 1*

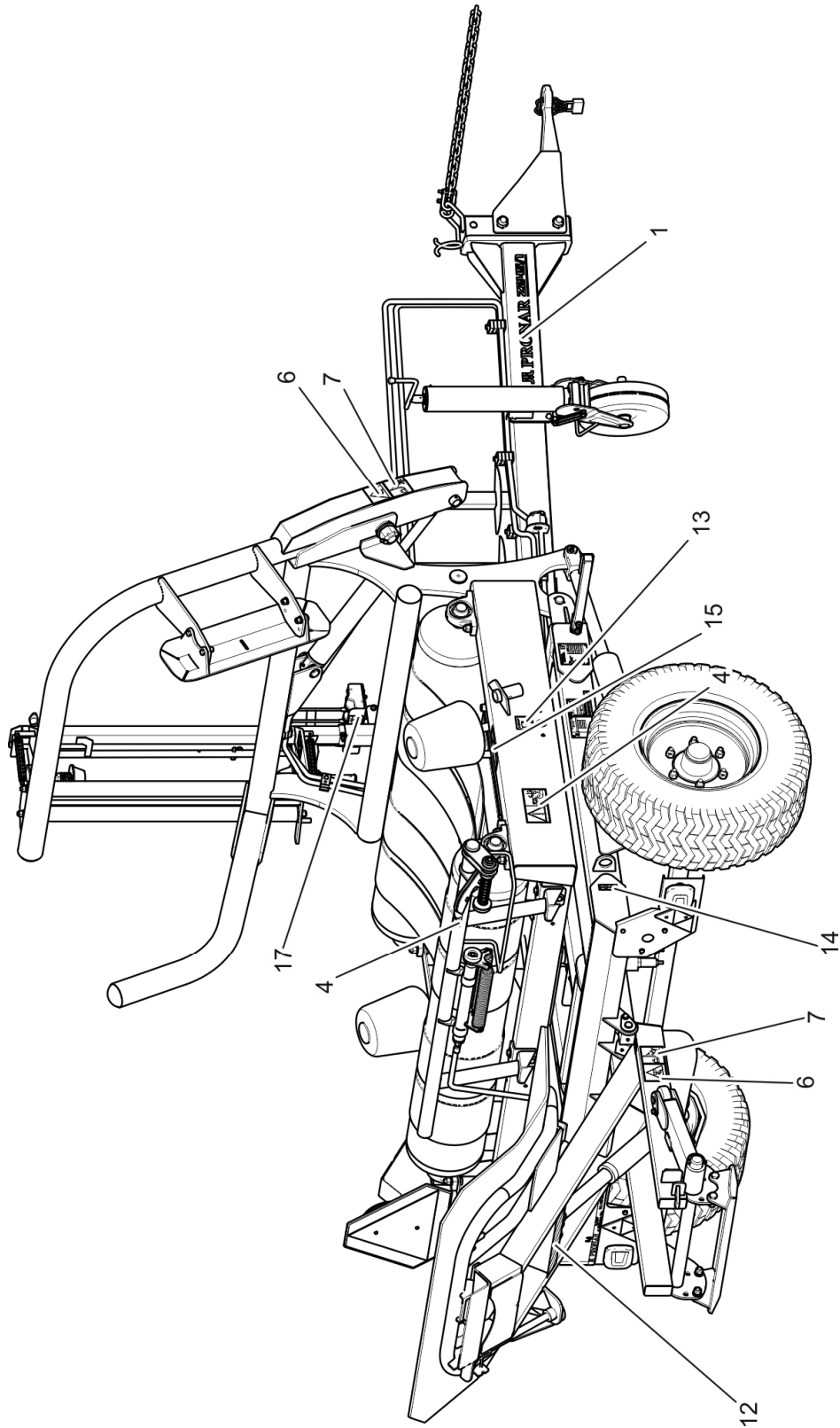

FIGURE 2.4 Arrangement of information and warning stickers, part 2

CHAPTER

3

**CONSTRUCTION AND
PRINCIPLE OF
OPERATION**

3.1 TECHNICAL CHARACTERISTICS

TABLE 3.1. *Basic technical data included as standard*

Content	Unit	Z245/1
Wrapper dimensions		
Length (Transport / Working)	mm / mm	5,890 / 6,100
Maximum width (transport / working)	mm / mm	2,220 / 3,370
Maximum height (transport / working)	mm / mm	2,570 / 2,570
Weight and load capacity		
The machine's karb weight	kg	1,650
Capacity	kg	1,000
Bale parameters		
Bale diameter (maximum)	mm	1,200 / 1,500
Bale Width (Maximum)	mm	1,250
Permissible gross weight	kg	1,000
Power train		
The permissible speed of the turntable	rev ⁻¹	25
Hydraulic motor oil flow	l/min.	about 30
Other information		
Film width	mm / mm	500 / 750
Noise level	dB	below 70
Min. tractor power	KM/ kW	35 / 48
Permissible design speed	km/h	30

3.2 WRAPPER DESIGN

The lower frame (1) of the wrapper is a welded structure made of steel sections. In the rear part of the frame, there is a road axle (7), unbraked, connected by U-bolts. A turntable (2) is mounted on the lower frame with the help of the tipping pins. On the side wall of the turntable there is a cutting unit that allows the film to be automatically cut off without leaving the tractor operator's compartment. In the front of the wrapper there is a foil feeder (3), suitable for unwinding 500 and 750 mm films. In the front part of the frame, the arm of the loading

mechanism (4) is mounted, hydraulically controlled by the distributor. An unloading mechanism (6) is installed at the rear of the frame.

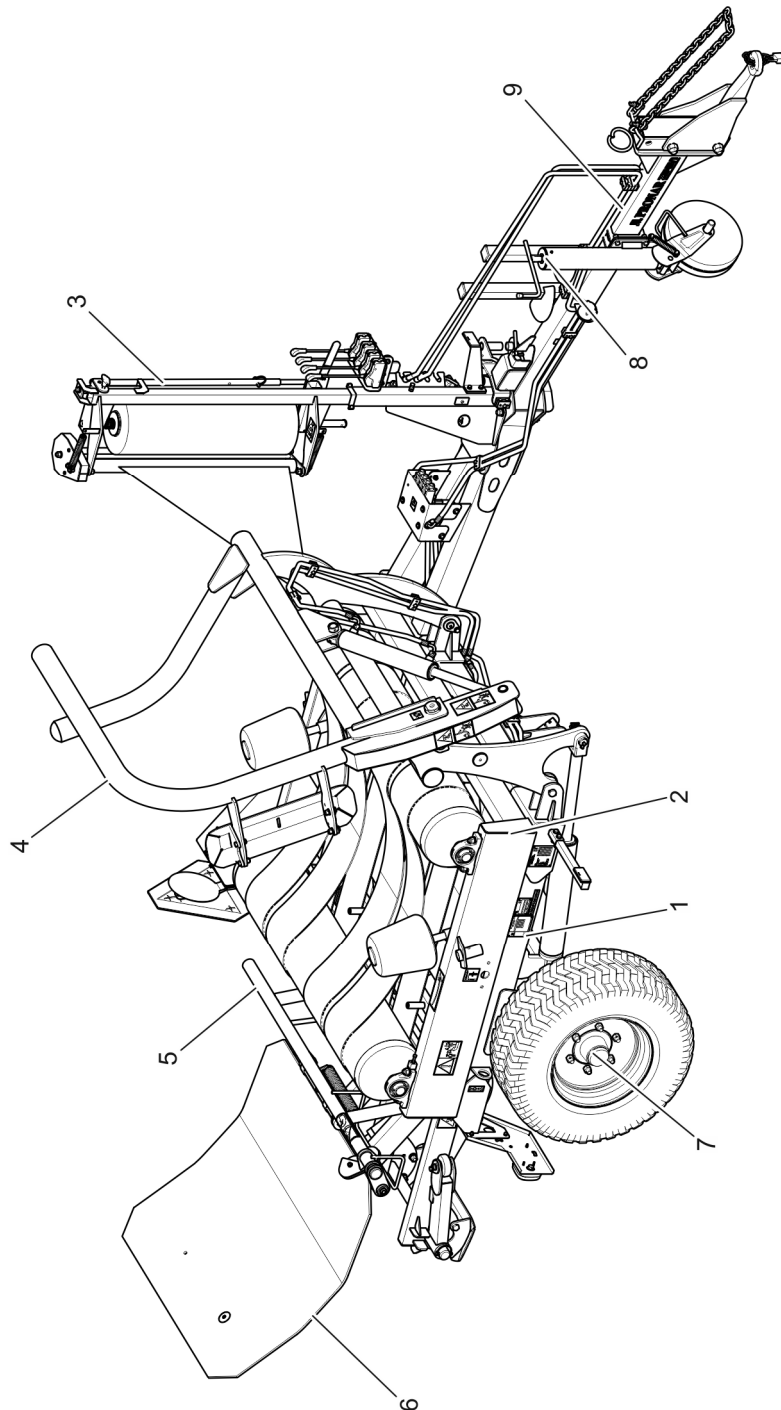
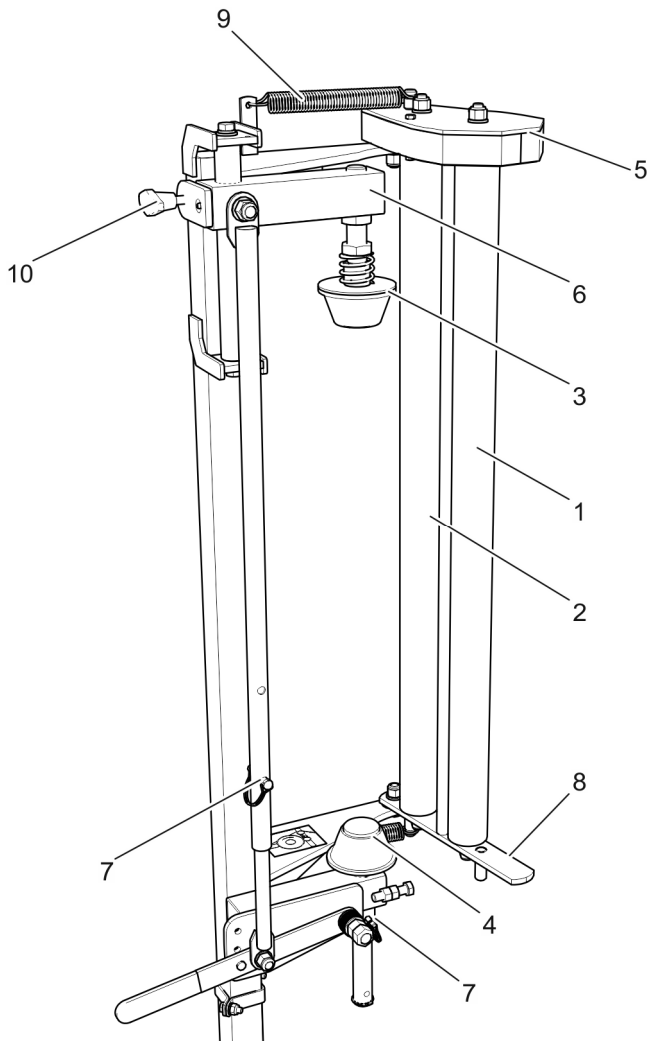

FIGURE 3.1 Construction of the Z245/1 wrapper

(1) lower frame, (2) turntable, (3) foil feeder, (4) loading arm, (5) cutting unit, (6) unloading mechanism, (7) axle, (8) support, (9) shaft

3.2.1 FILM FEEDER



The film feeder is mounted on the wrapper feeder mast. The mechanism is designed and adapted to unwrap the foil from a roll height of 500 or 750 mm. The film is fixed between the tapered roller support (3) and (4). The foil strap is passed through the vertical knurled tension pulleys (1) and (2). On the top of the feeder, there is a gearbox designed to change the rotation speed of the roller (1), which causes the belt to be wound up on the bale. The film tension can also be adjusted by the position of the upper support roller (3).

FIGURE 3.2 *Film feeder construction*

(1) roller I, (2) roller II, (3) upper supporting roller, (4) lower supporting roller, (5) gear housing, (6) clamp, (7) cotter pin, (8) frame lever, (9) spring, (10) locking screw

3.2.2 SWING FRAME, TURNTABLE

Refer to figures (3.3) and (3.4) for the design of the turntable. The tilting frame of the table (1) - Figure (3.3) is attached to the wrapper frame rear beam with pins. The frame is tilted by means of a telescopic cylinder (4) in order to unload the wrapped bale. A hydraulic motor (6) is bolted to the lower part of the tilting frame, which transmits the drive to the table's active roller through two chain transmissions and a bevel gear. A support (5) is mounted to the left

longitudinal member of the tilting frame, which is designed to protect the turntable against falling during maintenance or repair work.

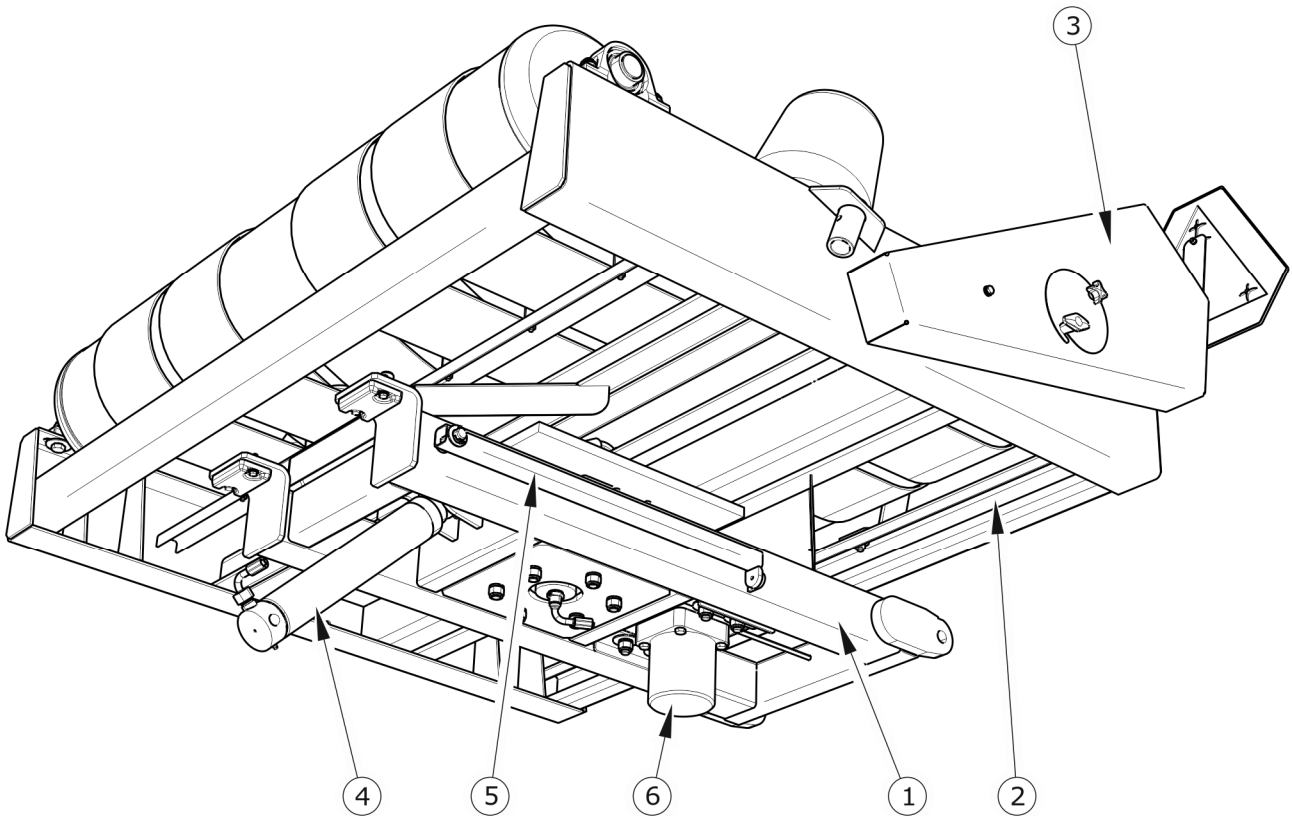

FIGURE 3.3 *Swing frame with turntable, bottom view*

(1) table tilting frame, (2) turntable, (3) transmission cover, (4) tipping hydraulic cylinder, (5) support, (6) hydraulic motor

The wrapped bale rests on reinforced belts (4) - figure (3.4), and is secured against shifting by means of resistance rollers (6). Figure shows the setting of the bale wrapping rollers up to 1 200 mm wide.

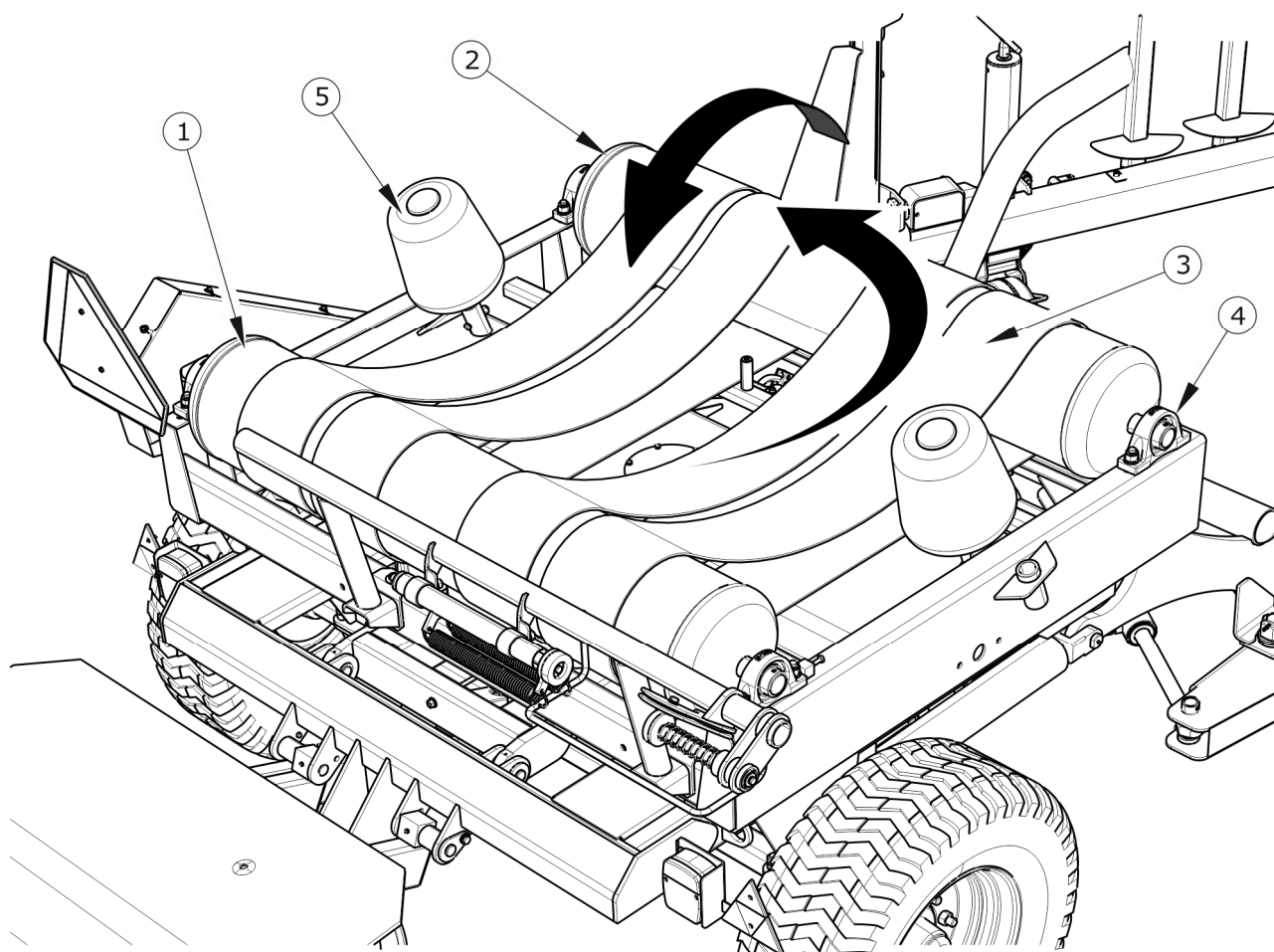

FIGURE 3.4 *turntable construction, bottom view*

(1) active roller, (2) passive roller, (3) belt, (4) bearing unit, (5) thrust roller

When the hydraulic motor is started, the turntable begins to spin with the bale around the vertical axis. At the same time, the bale driven by the active roller (2) rotates around the horizontal axis.

3.2.3 UNLOADING MECHANISM

The unloading mechanism is designed to discharge the bale and to set the bale in one of two possible positions. The layout is shown in Figure (3.5).

The mechanism frame (1) is attached to the beam of the rear wrapper frame with pins. On the swing frame there is an unloading table on which wrapped bales are unloaded.

The lateral tilt support (3), located on the right-hand side of the unloading mechanism, can be positioned in two positions – in figure (3.5), the support is in the unloading position backwards. In this case, the bale rolls from the mechanism table behind the wrapper after unloading. If the support is raised, when the arm is lowered, the mechanism table will lean

against the support slide (11) and rotate relative to the axis of the table pin (10). The bale will be placed on the left-hand side of the wrapper.

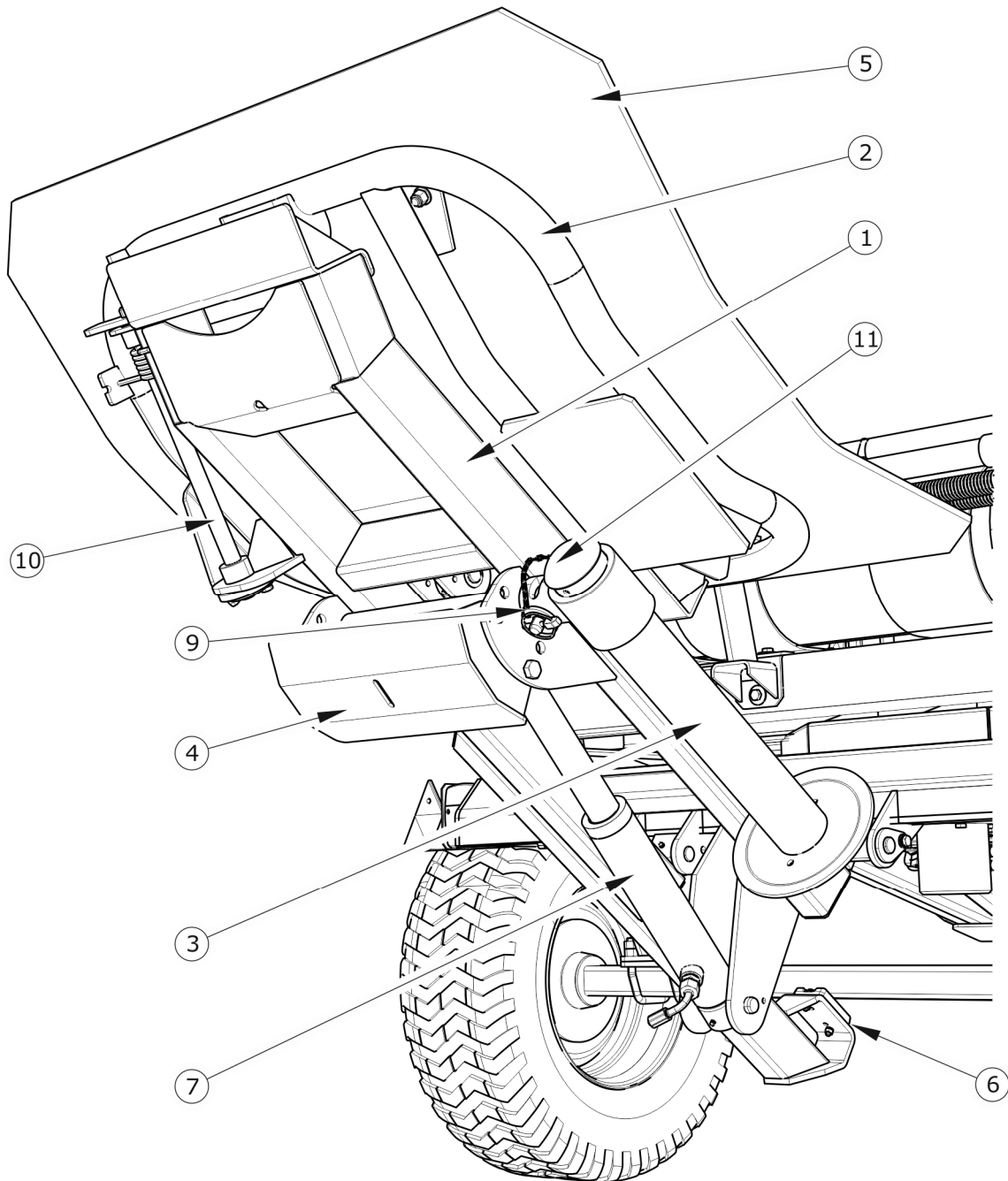

FIGURE 3.5 *Bale unloading mechanism*

(1) mechanism frame, (2) table frame, (3) side tipping support, (4) skid, (5) table rubber, (6) bumper, (7) tipping mechanism cylinder, (8) bumper, (9) support foot cotter pin, (10) table pin, (11) support slide

3.2.4 CUTTING UNIT

The cutting unit is located on the side member of the turntable frame. The task of the unit is to cut off and hold the film until the next bale is wrapped. The film is cut off from the tractor by extending the hydraulic cylinder (2), controlled by the distributor.

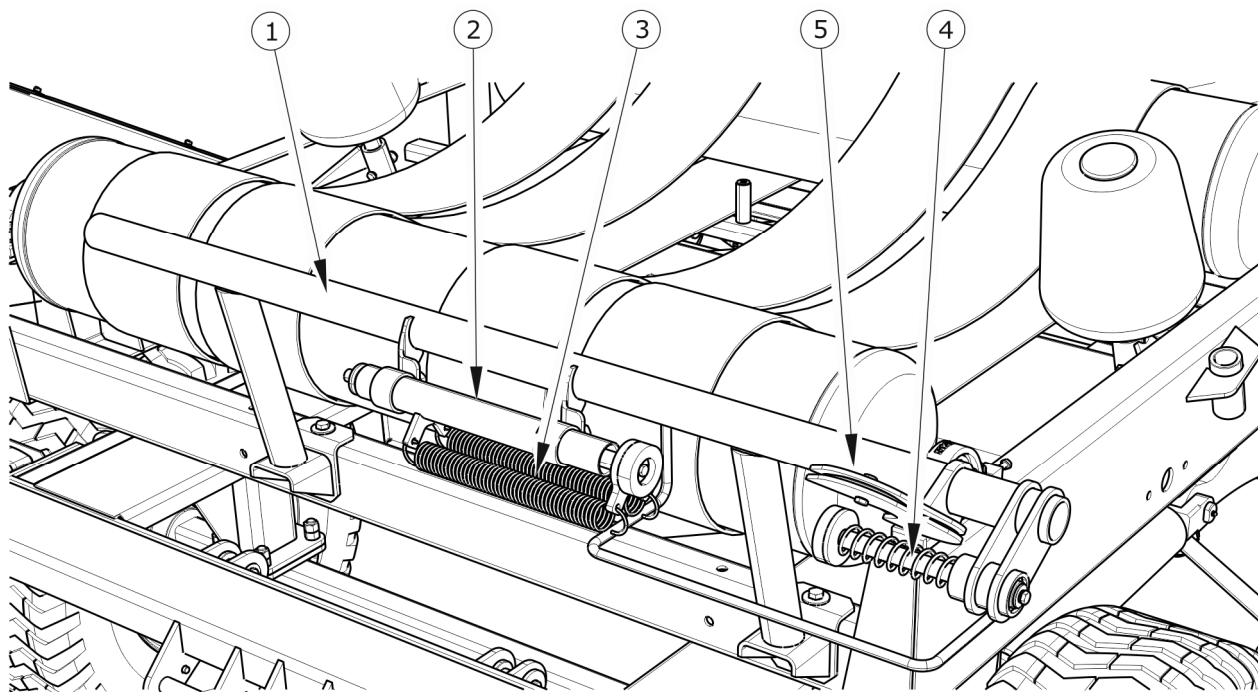

FIGURE 3.6 *Cutting mechanism*

(1) assembly frame, (2) hydraulic cylinder, (3) tension springs, (4) foil hold-down, (5) cutting knives

3.2.5 ELECTRICAL INSTALLATION, WARNING ELEMENTS

The electrical wiring of the wrapper is designed to be powered from a 12 V DC source. The wiring of the wrapper to the tractor must be connected with a suitable connection cable with a seven-pin socket. The electrical system of the wrap counter is a separate independent circuit, with its own battery power if the counter L01 is fitted (standard equipment) or a separate power cord if the counter L02 is fitted (optional equipment). Connect the adapter cable for counter L02 to the corresponding power outlet on the tractor. The wiring diagram for the wrapper is shown in figure (3.9).

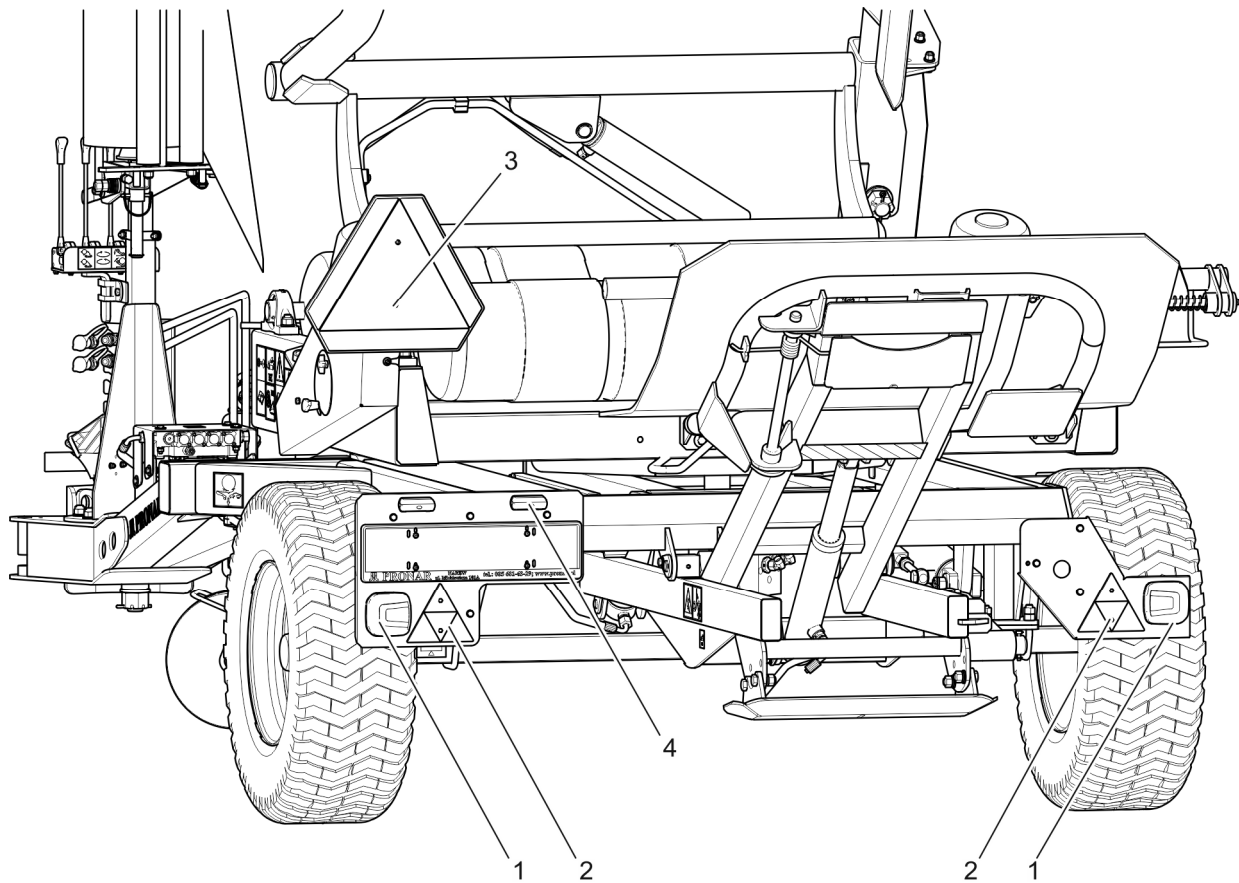

FIGURE 3.7 Arrangement of electric lighting elements and reflectors

(1) rear combination lamp, (2) reflector triangle, (3) distinguishing plate, (4) number plate lighting,

TABLE 3.2. Designation of connections of the 7-pin connection socket

MARKING	Function
31	Weight
+	+12V supply (not used)
L	Left direction indicator
54	STOP light
58L	Rear left position light
58R	Rear right position light
R	Right direction indicator

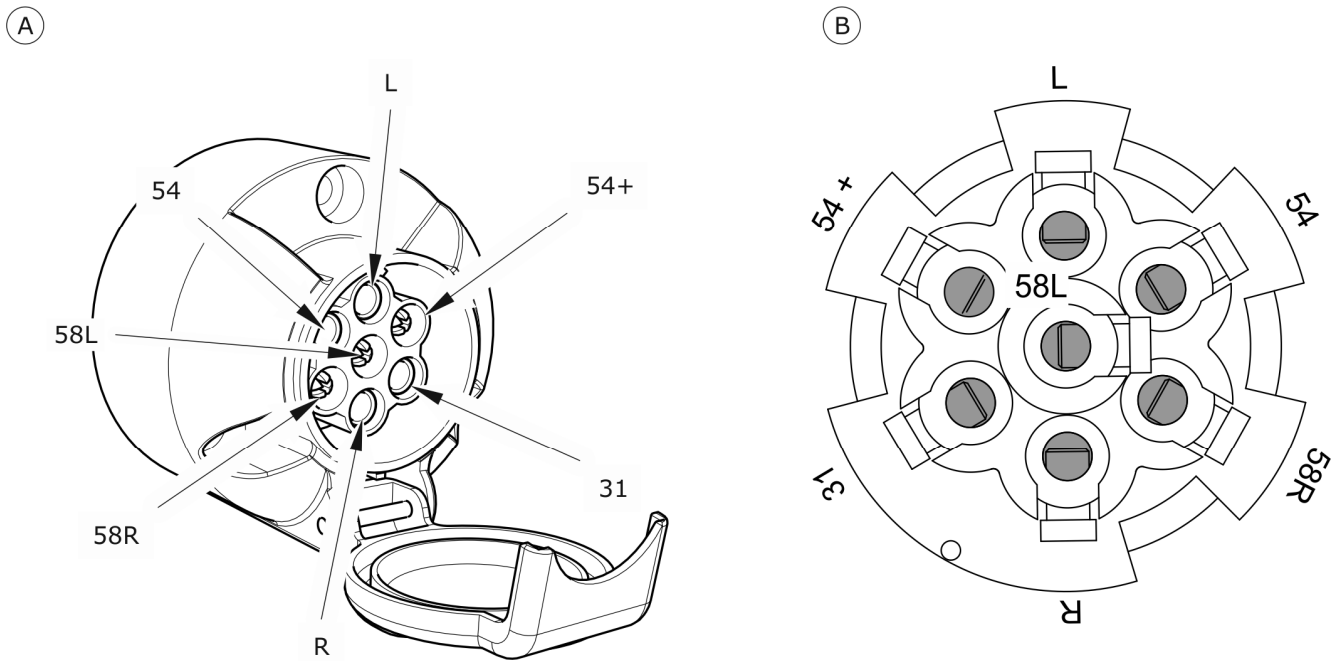

FIGURE 3.8 Connection socket

(A) Socket view, (B) Socket view from harness wire mounting side

The counter is an electronic device designed to count the wraps of a bale. The set consists of a programmable counter located in a plastic housing and a rotation sensor, connected by a wire and a multi-pin connector. The sensor mounted on the stationary part of the wrapper design works with a permanent magnet placed on the rotating table and transmits electrical signals to the counter system. Each full turn of the wrapped bale is counted and shown on the counter display. When the number of wraps programmed by the user has been counted, the counter flashes to indicate the end of wrapping. The counter can be programmed with 16 or 24 wraps depending on the foil used (for counter L01 supplied as standard) or 10 to 49 wraps (for counter L02 as an option). The L01 has a battery power supply, while the L02 has a separate connection cable, which must be connected to the corresponding socket on the tractor.

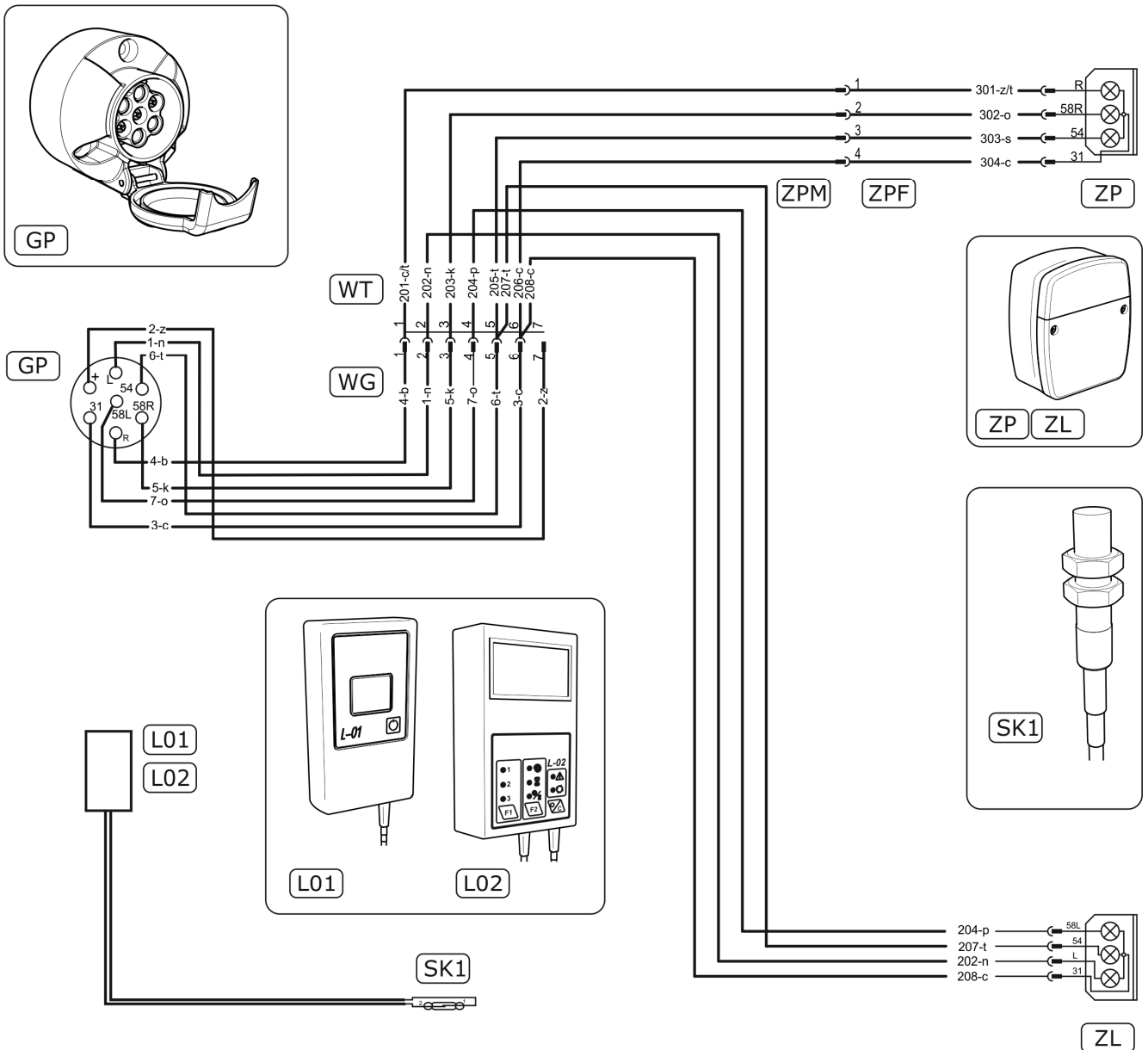

FIGURE 3.9 Electrical system diagram

(ZL) rear combination lamp left, (ZP) rear combination lamp right, (GP) connection socket 7-pin, (L02) wrap counter, (SK1) revolution sensor

3.2.6 THE HYDRAULIC SYSTEM

The hydraulic system of the wrapper is designed to control the operation of individual systems by means of a hydraulic distributor. The hydraulic circuit diagram is shown in Figure (3.10).

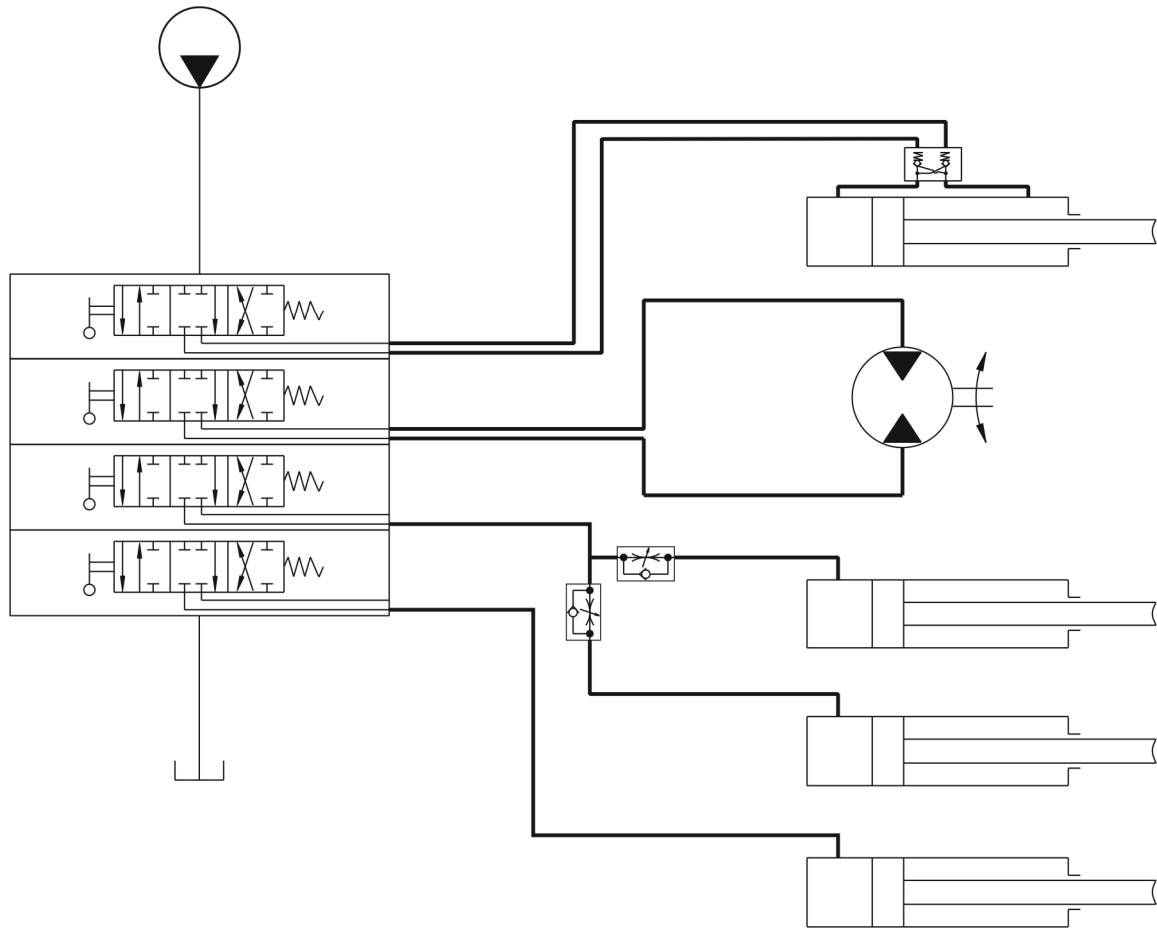
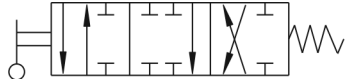
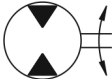
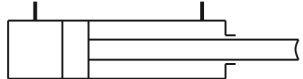
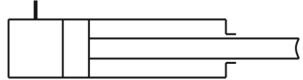
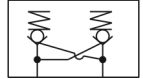
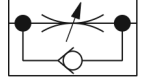

FIGURE 3.10 Diagram of the hydraulic system

TABLE 3.3. Importance of symbols

Symbol	Meaning
	Hydraulic distributor section.
	Hydraulic motor.
	Double-acting hydraulic cylinder.
	Single acting hydraulic cylinder.
	The hydraulic lock.
	Hydraulic oil flow regulator.

As standard, the wrapper is equipped with a hydraulic distributor controlled by cables, Figure (3.11). The meaning of the different sections of the distributor is shown by an information label (1) affixed to the support.

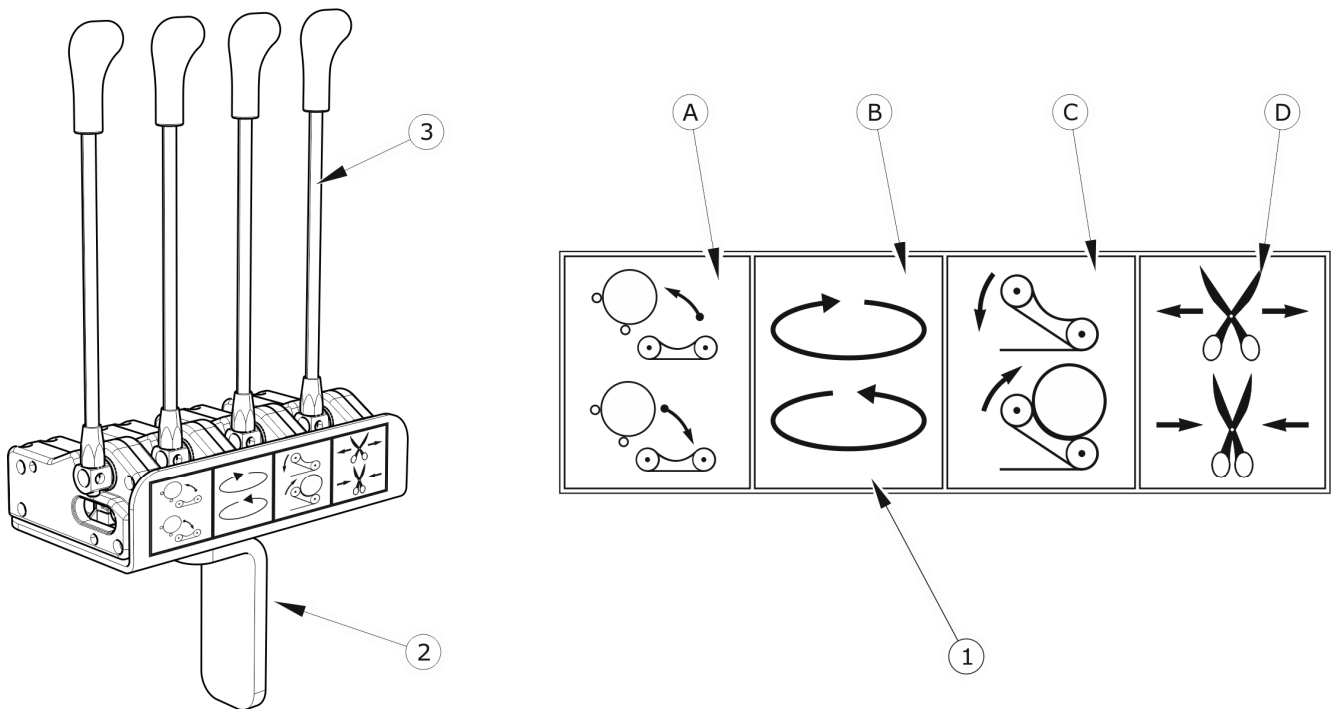

FIGURE 3.11 Control levers

(1) information sticker, (2) bracket, (3) lever, (A) control of the loading arm, (B) rotation of the turntable, (C) control of lifting and lowering of the turntable and unloading arm, (D) control of the cutting system cylinder

The information labels (16) – TABLE (2.1) are also marked with the connection cables. Labels indicate the right direction of hydraulic oil flow.

ADVICE



The hydraulic system of the wrapper was filled with L-HL32 Lotos hydraulic oil.
An additional mounting bracket for the bracket is included in the machine's standard equipment and is designed to be mounted in the operator's cabin of a farm tractor.

CHAPTER

4

**CONSTRUCTION
AND PRINCIPLE
OF OPERATION RULES
OF USE**

4.1 PREPARATION OF THE WRAPPER FOR WORK

4.1.1 PRELIMINARY INFORMATION

The manufacturer ensures that the wrapper is fully functional, has been checked in accordance with control procedures and is approved for use. However, this does not release the user from the obligation to check the machine after delivery and before first use. The wrapper is delivered to the user completely assembled. Wrap counter with cable, mounting bracket for control levers bracket, connection cable for electrical system, gear wheel Z45 and chain (9 links) are packed separately.

4.1.2 CHECKING THE WRAPPER AFTER DELIVERY

CAUTION



The seller is obliged to start the wrapper for the first time in the presence of the user.

Training by the seller does not release the user from the obligation to become familiar with the contents of this manual.

After delivering the machine to the recipient, the user is obliged to check the technical condition of the trailer - (one-time inspection). During the purchase, the user must be informed by the seller about the use of the machine, the dangers arising from improper use, how to connect the machine with the principle of operation and construction. Detailed information on the transfer can be found in the *WARRANTY CARD*.

- Check the machine assembly according to your order.
- Check technical condition of guards,
- Check the condition of the paint coating, check for any signs of corrosion.
- Inspect the machine for damage resulting from improper transport of the machine to the destination (dents, punctures, bends or broken parts, etc.).
- Check the tire inflation pressure and check that the traction wheel nuts are correctly tightened.
- Check the technical condition of the drawbar eye and its attachment.

Do not aggregate and start the wrapper if any irregularities are detected. Any defects found must be reported directly to the seller in order to remedy the defects.

4.1.3 PREPARATION FOR INITIAL START-UP, TEST START OF TRAILER



ADVICE

All operations related to the wrapper are described in detail later in this manual.

PREPARING FOR A TEST START

- Read the contents of this *USER'S MANUAL* and follow the recommendations contained therein.
- Visually inspect the machine according to the instructions in the chapter *PREPARING THE WRAPPER FOR DAILY OPERATION*.
- Check all wrapper lubrication points, if necessary, lubricate machine as recommended in *CHAPTER 5*.
- Check the correct tightening of the wheel's nuts.
- Remove the knife guard, clean the knives of any remaining maintenance grease.
- Adjust the turntable roller drive, cutter position, tongue and foil feeder.
- Make sure that the hydraulic and electrical connections on the agricultural tractor comply with the requirements, otherwise do not connect the wrapper.
- Install battery into wrap counter, program counter.
- Check the condition of the rubber belts on the turntable.
- Install the mounting bracket for the panel with the control levers in the tractor operator's cab.

TEST RUN

If all of the above activities have been carried out and the technical condition of the wrapper does not raise any objections, connect the machine to the tractor. Start the tractor, check individual systems and carry out a test run of the wrapper and perform a test drive without load. It is recommended that visual inspection be carried out by two people, one of them

should be permanently in the tractor's cab. The test run must be carried out in the order shown below.

- Connect the wrapper to the appropriate hitch on the agricultural tractor.
- Connect the electrical and hydraulic system hoses.
- By activating individual lights, check the correct operation of the electrical system.
- Operate the wrapper divider to operate the turntable drive for 1 minute (no bale loaded), check the wrap counter for correct readings.
- Stop the wrapper, place the table in the bale unloading position. Check the unloading mechanism for correct operation by operating the distributor lever.
- Check the other hydraulic circuit (load arm and cutter bar).
- Perform a test drive.
- Stop the tractor engine, immobilize the tractor with the parking brake, check the hydraulic system for leaks.

**ADVICE**

All operations related to the wrapper are described in detail later in this manual.

The turntable and rollers should rotate smoothly, without jams and excessive noise. The correct rotation direction of the table is indicated by the information labels – Table (2.1). The electronic counter should increase the indication value by 1 in the case of a full turn of the table, and after completing the programmed number of rotations, the counter indicator should blink (information on L02 counter indications - optional equipment - is described later in this chapter). In the event of a malfunction, locate the fault. If it cannot be removed or removal may void the warranty, please contact your retailer for clarification.

DANGER

Careless and improper use and operation of the wrapper, non-observance of the recommendations contained in these instructions creates a threat to health.

The wrapper must not be used by persons who are not authorized to drive agricultural tractors, including children and people under the influence of alcohol or other drugs.

Non-compliance with the rules of safe use poses a threat to the health of the operating and bystanders.

4.1.4 PREPARATION OF THE WRAPPER FOR WORK

The scope of control activities

- ➔ Visually assess the condition of inflation of the road wheels. If in doubt, carefully check the air pressure.
- ➔ Assess the condition of the tongue tie rod.
- ➔ Check proper operation the electrical system.
- ➔ Check technical condition of guards,
- ➔ Install a triangular marking plate for slow-moving vehicles if the wrapper is to be driven on public roads.

4.2 CONNECTING AND DISCONNECTING OF THE WRAPPER TO THE TRACTOR

The wrapper may be connected to an agricultural tractor, if all connections (electrical, hydraulic) and the hitch on the agricultural tractor are in accordance with the machine manufacturer's requirements. In order to connect the wrapper with the tractor, perform the following actions in order.

CONNECTING

- ➔ Position the agricultural tractor straight in front of the drawbar eye of the wrapper.
- ➔ Using the support, position the drawbar tie rod at a height that allows the machines to be connected.
- ➔ Remove the drawbar protection.

- ➔ Reverse the tractor, connect the wrapper to the appropriate hitch in the tractor, check the coupling protection protecting the machine against accidental disconnection.
- ➔ If an automatic coupling is used in the agricultural tractor, make sure that the aggregation operation is completed and the drawbar eye is secured.

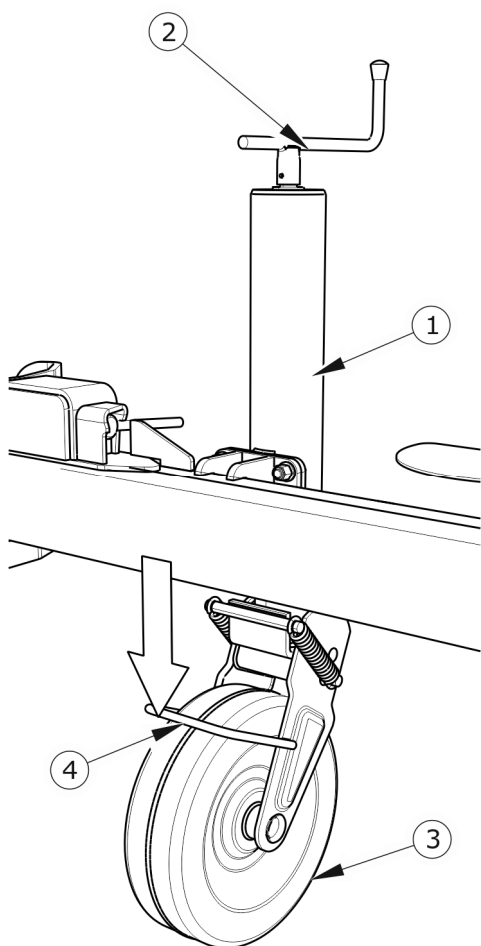

FIGURE 4.1 *Wrapper support*
 (1) support, (2) crank, (3) wheel, (4) pedal

- ➔ Switch off the tractor engine. Close the tractor cabin and secure it against unauthorized access.
- ➔ Connect the safety chain to a durable and stable element of the tractor (e.g., field hitch), which will not be damaged by the chain jerking during an emergency.
- ➔ Guide the emergency safety chain so that it does not strain during turns and rough terrain.
- ➔ Connect hydraulic system hoses.
- ➔ The supply (1) and return (2) lines, Figure (4.2), are marked with information labels. Connect the return hose to the "free drainage" outlet (outlet with free oil drain to the reservoir).
- ➔ Connect the main power supply cable for the lighting installation.
- ➔ Lift the bearing wheel by turning the crank (2) as shown (4.1).
- ➔ Depress the support pedal (4) and hold the wheel (3) by hand, fold it into the driving position.

- ➔ Place the wrap counter in the tractor cab in a visible position. The cable connecting the wrap counter to the revolution sensor should only be connected before starting work.
- ➔ After completing the coupling, secure the hydraulic and electrical wiring in such a way that they do not become entangled in the moving parts of the agricultural tractor during travel and are not exposed to kinking or cutting during turning.

CAUTION



The wrapper may only be coupled to an agricultural tractor with a suitable hitch, the required hydraulic and electrical connection sockets.

Pay attention to the compatibility of oils in the tractor hydraulic system and in the hydraulic system of the tilting system

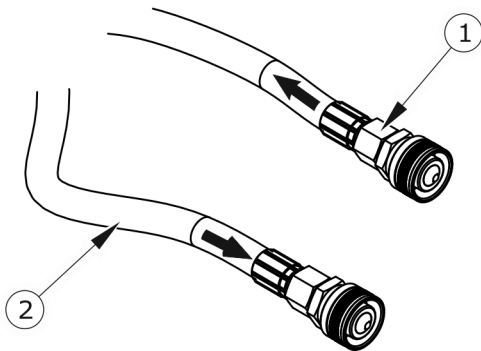

FIGURE 4.2 Identification of hydraulic hoses

(1) supply line, (2) return line

Before working with the counter, a revolution sensor must be connected to the counter. The sensor is connected to the meter by means of a set of plugs and socket installed at the factory on the meter and sensor wires. Ensure that the cable is not exposed to accidental mechanical damage when guiding to the meter. A common case is that the tractor wheel is pulled over the cable, which causes it to be pulled out of the sensor housing and permanently damaged. Also, be

careful that the hose pulled by the tractor wheel (or otherwise) does not cause the meter to fall from the tractor to the ground.

DANGER



During coupling it is forbidden to stand bystanders between the wrapper and the tractor. The agricultural tractor operator when connecting the machine should take particular care during work and make sure that unauthorized persons are not in the danger zone during coupling.

When connecting the hydraulic conduits to the tractor, make sure that the tractor hydraulic system and wrapper are not under pressure.

Ensure good visibility during coupling.

Take special care when folding the support, risk of pinching the limbs.

After completing the coupling check the safety of the coupling bolt.

CAUTION



If the meter falls from a small height, it can be permanently damaged.

DISCONNECTING OF THE WRAPPER

In order to disconnect the wrapper from the tractor, perform the following actions in order.

- ➔ If necessary, lower the turntable, the unloading arm and the loading arm.
- ➔ Immobilize tractor with parking brake, turn off tractor engine.
- ➔ Disconnect the speed sensor cable from the wrap counter.
- ➔ Close the tractor cabin and secure it against unauthorized access.
- ➔ Turn the support wheel to the parking position.
- ➔ Turn the crank and set the drawbar eye at such a height that it is possible to unlock and disconnect the wrapper.
- ➔ Disconnect the hydraulic system hoses from the tractor.
- ➔ Secure the cable ends with covers. Fit the cable plugs into their sockets or secure them with the plugs.
- ➔ Disconnect the electric wire.
- ➔ Remove the control lever panel from the tractor and place it on the support in the wrapper.
- ➔ Unlock the tractor's hitch, disconnect the wrapper's hitch from the tractor's hitch.
- ➔ Secure a device to prevent unauthorized use.

DANGER



When disconnecting the wrapper from the tractor, take particular care. Ensure good visibility. Unless it is necessary, do not stay between the wrapper and the tractor.

Before disconnecting wires and drawbar eye, close tractor cab and secure it against unauthorized access. The tractor engine must be turned off.

CAUTION



The turntable and the unloading mechanism must be lowered before the wrapper is disconnected. Secure the load arm with the locking device.

4.3 FOIL PLACING

The feeder design allows the installation of two types of polyethylene film with widths of 500 mm and 750 mm.

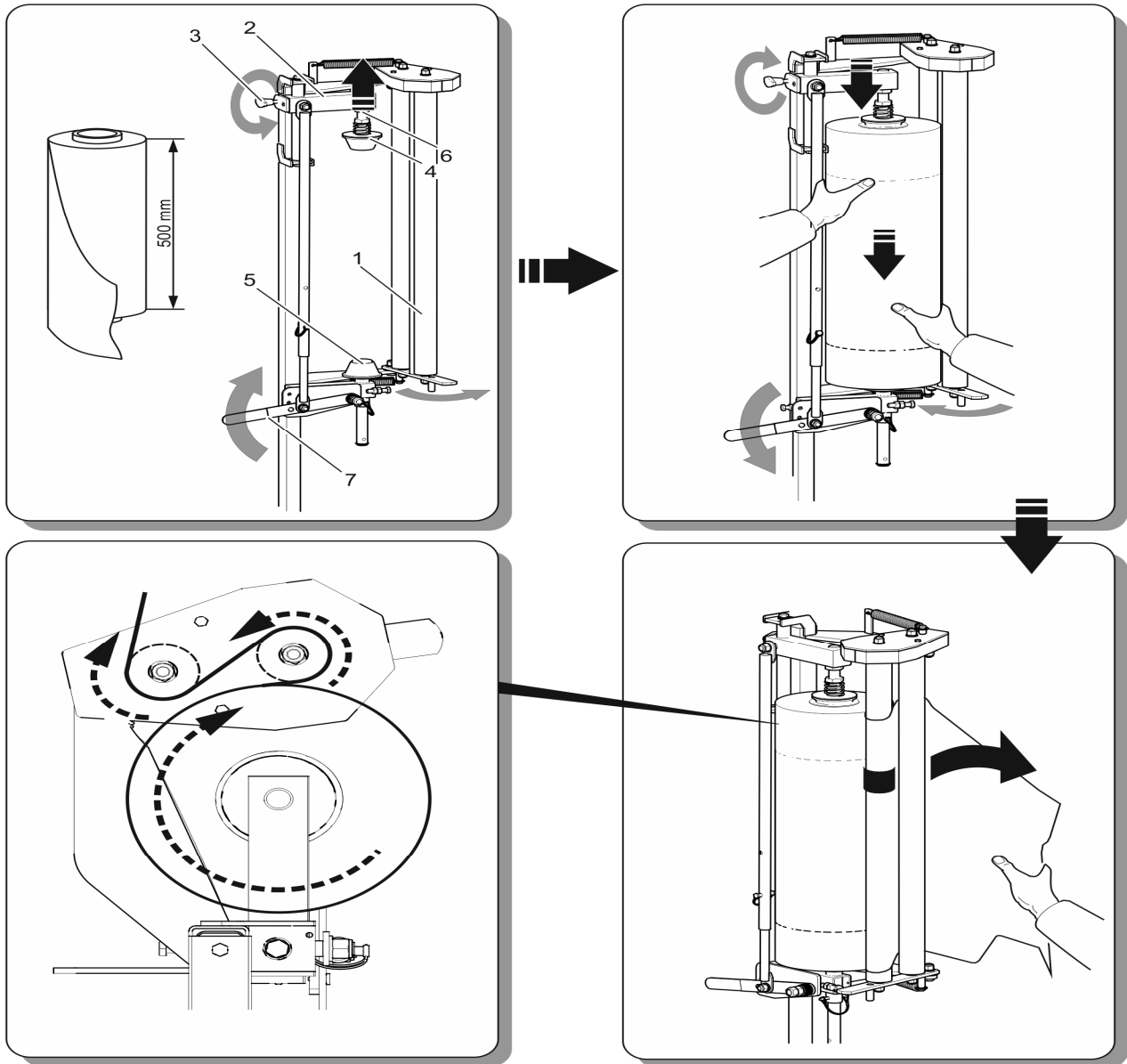

FIGURE 4.3 *Installation of a 500 mm wide film.*

(1) swing frame, (2) pressure plate, (3) cotter pin, (4) upper pressure roller, (5) lower pressure roller, (6) nut

Figure (4.3) shows the installation of a 500 mm wide film. To install the roller, follow the instructions below in the order of fitting.

- ➔ Clean the guide rollers of any adhesive residue or other debris.
 - ⇒ It is recommended to use extraction gasoline when cleaning the glue.

- ➔ Tilt the swing frame (1) to its extreme anti-clockwise position.
- ➔ Release and remove the upper cotter pin (3).
- ➔ Move the clamp (2) upwards.
- ➔ Place a 500 mm wide film on the lower pressure roller (5).
 - ⇒ The roller must be installed in such a way that the adhesive layer must be on the inside, i.e., it must be against the bale to be wrapped.
- ➔ Move the piston (2) downwards and secure it with the cotter pin (3),
- ➔ Unfasten the end of the film (or remove the roll packaging), unwrap a piece of film.
- ➔ Rotate swing frame to home position.
- ➔ Feed the removed piece of film through the feed rollers according to the diagram on the feed label.

**ADVICE**

Installation of a 750 mm wide film requires adjustment of the foil feeder to this type of rolls. The use of a wider film makes it necessary to change the transmission ratio of the turntable. Refer to Chapter 5 for details.

The film feeder must be adjusted to the correct height to allow different film widths and to wrap bales with different diameters. The optimal position of the feeder is that the centre of the installed film roll must be at the same height as the centre of the wrapped bale. To adjust the feeder to the current operating conditions, loosen the screws (2) – Figure (4.4), move the feeder to the optimum position and tighten the screws (2). Secure the feeder with the clamp (4).

**DANGER**

Before installation of the film, turn off the tractor engine and remove the ignition key.

After installation of the film, carefully check the roll attachment, the tightness of the screw connections and the safety pins are correctly fitted.

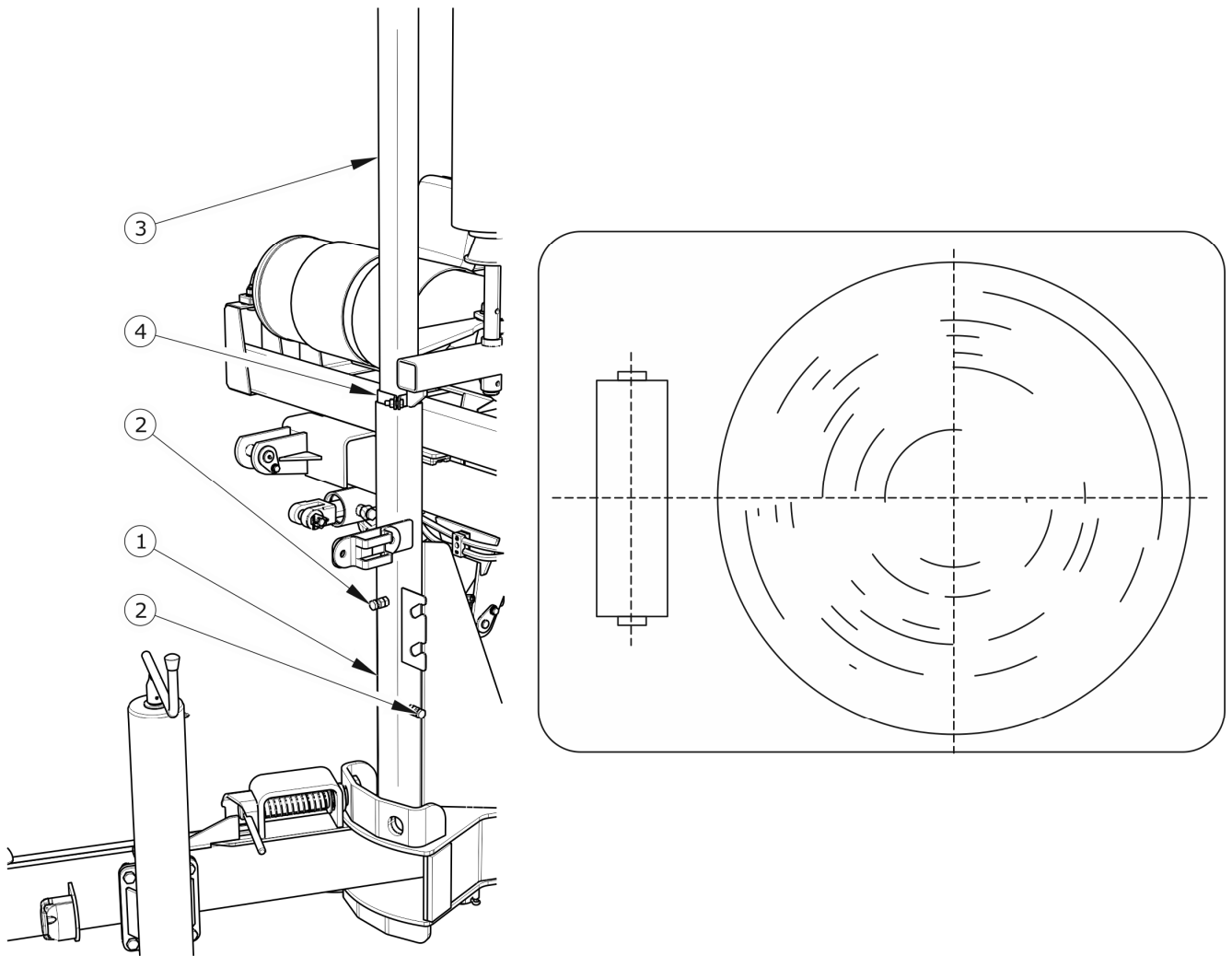

FIGURE 4.4 *Adjust the height of the film feeder*

(1) bottom profile, (2) locking screws, (3) foil feeder frame profile, (4) clamp

4.4 FOLDING AND UNFOLDING OF THE DRAWBAR

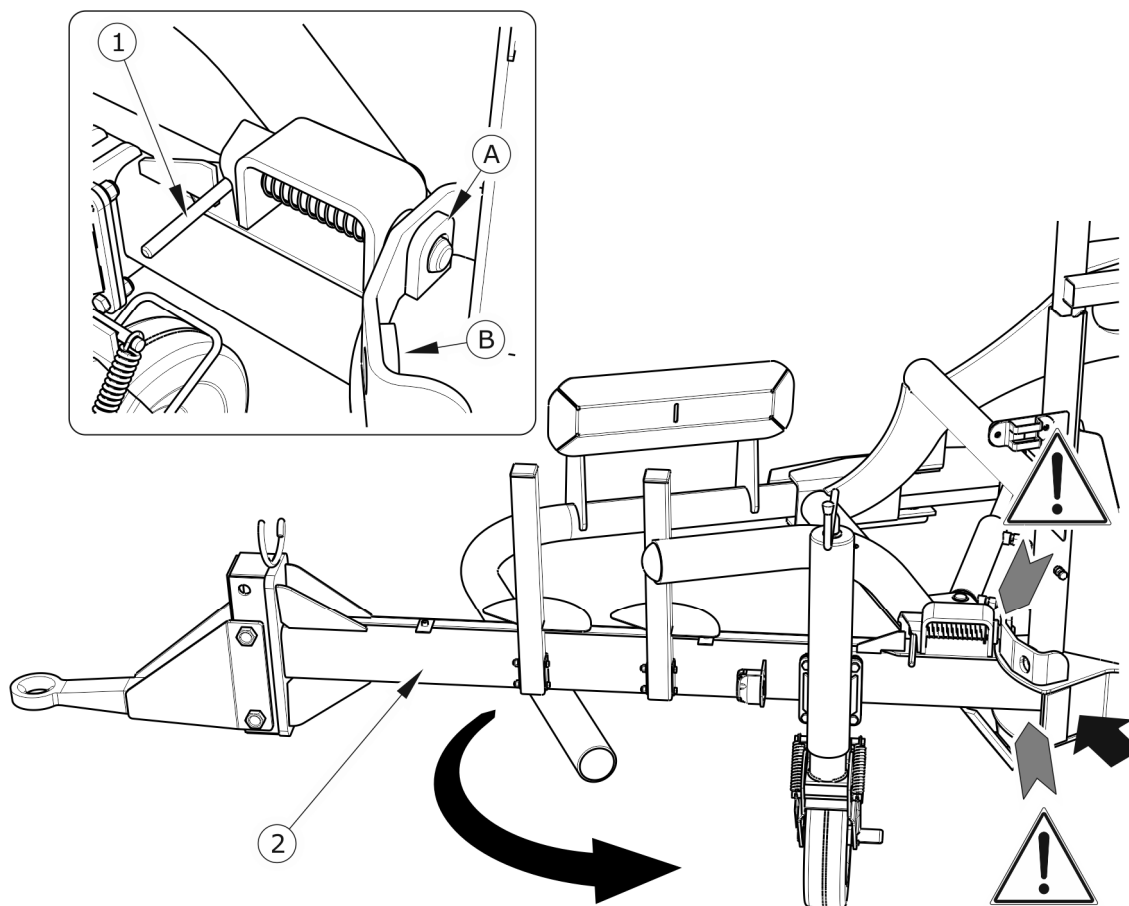

FIGURE 4.5 Setting the drawbar in the *WORK* position

(1) locking pin, (2) drawbar, (A), (B) locking pin positions

After reaching the field, before wrapping, set the machine's drawbar to the *WORK* position. To do this:

- ➔ Secured tractor with parking brake.
- ➔ Pull out the locking pin (1) and leave it in the unlocked position.
 - ⇒ The pin handle rests against the slide plate in the vertical position.
- ➔ Push the wrapper frame and fold the tongue into the *WORK* position.
- ➔ If the drawbar does not want to move, place a wedge under the wheel and move the tractor slowly, and then set the drawbar manually again.
- ➔ Secure the locking pin by lowering the lever to the horizontal position.
 - ⇒ Pin should be placed in hole (B).

Folding the drawbar to the *DRIVING* position is done in the reverse order.

DANGER



The support wheel must be in the transport position, that is, it must be fully raised.

Danger of fingers crushing. Do not place your hands in the areas marked with the CAUTION mark (4.5).

4.5 LOADING

Before loading the bale, make sure that the wrapper is properly connected to the tractor.

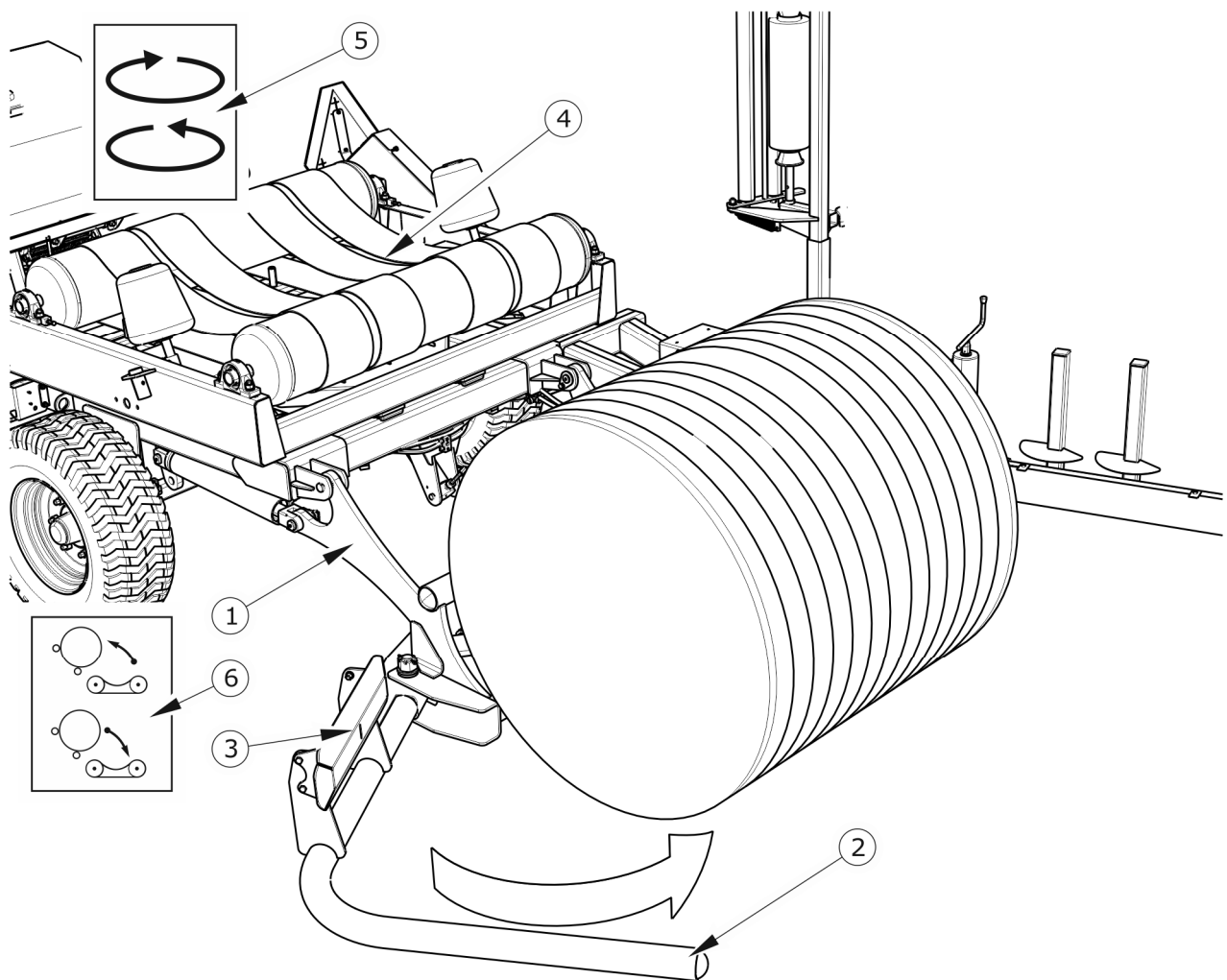

FIGURE 4.6 Bale Load Level 1

(1) loading arm, (2) gripper arm, (3) pusher, (4) turntable, (5), (6) information sticker

THE SCOPE OF ACTIVITIES

- ➔ Move the wrapper drawbar to the run position (if not already done).
- ➔ Remove the triangular warning plate.
- ➔ Rotate the turntable (4) to the bale loading position. The cutting unit should be at the rear of the wrapper.
 - ⇒ Use the decal-marked divider lever (5) to rotate the table.
- ➔ Lower the load arm (1) to the ground. The load arm and the gripper arm (2) are connected in a single hydraulic system. Hold the lower lever until the gripper arm (2) opens completely.
 - ⇒ The arm is controlled by means of a lever marked with an information sticker (6).
- ➔ Drive the tractor to the bale so that the bale is as close to the left-hand side of the load arm as possible.
- ➔ Raise the bale using the load arm control lever.
 - ⇒ The gripper arm will close first and only then the bale will be lifted by the load arm.
- ➔ Load the bale on the wrapper turntable.
 - ⇒ During the final loading phase, the bale will automatically move to the wrapper turntable.
- ➔ Lower the load arm to the height at which the bale can be wrapped.



DANGER

When loading a bale, do not allow bystanders to be in the wrapper operation area, especially close to the load arm and turntable.



CAUTION

The bale must only be loaded on the turntable when the wrapper is stopped.

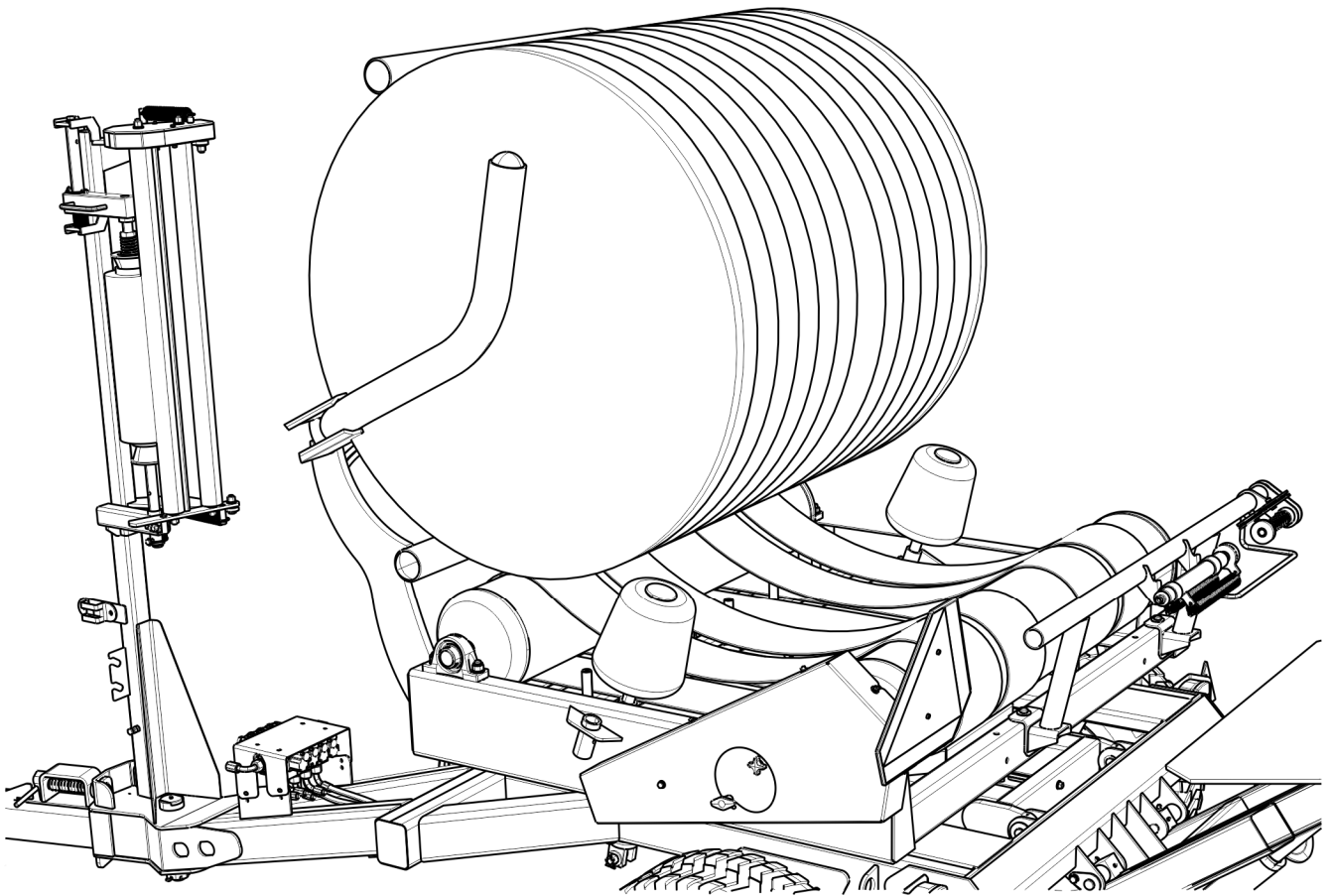

FIGURE 4.7 *Bale Load Level 2*

4.5.1 WRAPPING

The wrapping film is fed automatically from the feeder and there is no need to leave the tractor cab to prepare for wrapping. The exception is the beginning of work or the case of foil breaking. Pull the film off the feeder by hand and thread the end of the film through the twine of the compressed bale.

Try to maintain a constant table speed while wrapping the bale. The number of wraps depends on the purpose of the bale and the feed technology. It is recommended that the bale be wrapped in at least 4 layers, but more may be required depending on the material to be wrapped. The number of revolutions of the table depends on the size of the bale.



DANGER

Before wrapping a bale, make sure that there are no bystanders or obstructions near the rotating area of the screed that will prevent the machine from operating properly.

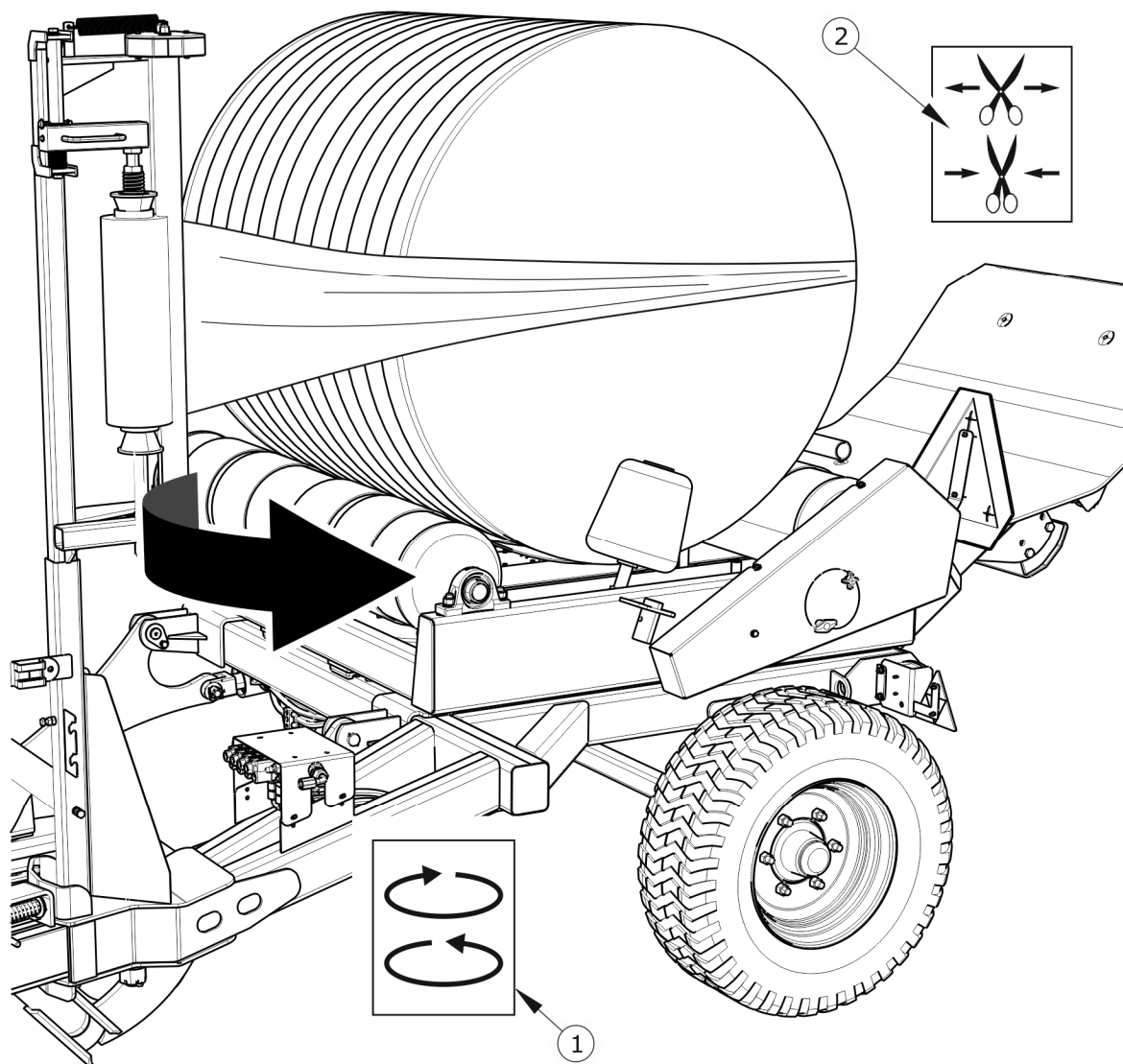

FIGURE 4.8 Preparation to wrap the first bale

(1), (2) information stickers

WRAPPING OF THE BALE

- ➔ After the first bale is loaded, unwrap a portion of the film from the feeder and pass the end of the film through the bale twine. When another bale is wrapped, the end of the cut wrapping film is held by the cutter actuator until the bale is loaded. At this point, retract the cutter bar cylinder to the park position.
 - ⇒ The pressing cylinder of the cutting system is controlled by means of a lever marked with an information sticker (2).
- ➔ Operate the table drive in the direction of rotation indicated by the arrow.
 - ⇒ The movement of the table is controlled by a lever marked with a sticker (1).
- ➔ Wrap the bale as many times as necessary.

- ➔ The number of wraps is indicated by the rev counter, (detailed operation is described later in this chapter).
- ➔ Check the foil tension while wrapping and adjust the feeder if necessary.

CAUTION



Do not wrap bales other than those specified in this manual.

The wrapper's maximum carrying capacity must not be exceeded.

It is not permitted to operate the machine on slopes.

Adjust the turntable speed to suit the size and weight of the bales to be wrapped.

CALCULATION OF THE REQUIRED NUMBER OF WRAPS

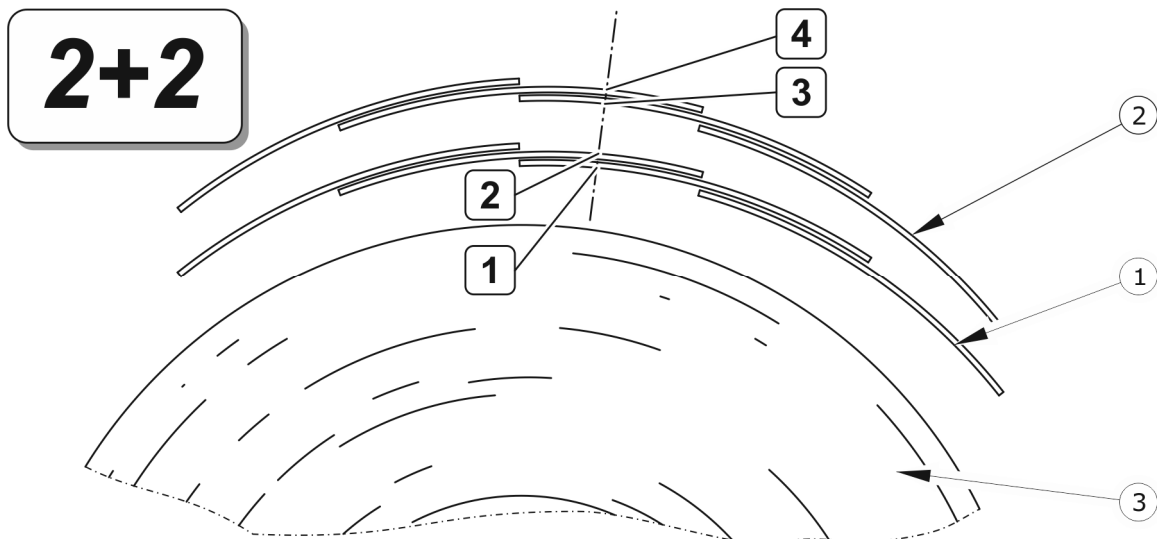

FIGURE 4.9 Wrapping of a bale in the 2+2 system

(1) film layer after first complete wrapping, (2) film layer after second complete wrapping, (3) bale

CAUTION



Do not use wrapping film that is not suitable for use with the machine.

It is forbidden to exceed the permissible rotational speed of the turntable (25 rpm).

It is permitted to wrap the bale while driving only when the vehicle is travelling on level ground. Do not exceed the permitted ground speed during operation. During simultaneous travel and wrapping, the load arm must not be lowered completely to the ground. Raise the bale so that the bale can be wrapped in no collision and the uneven ground will not interfere with machine movement.

Determining the number of bales wraps correctly has a significant impact on the quality of silage. Film manufacturers recommend using the 2+2 system during wrapping (subsequent layers must be at least half the width of the previous belt – 50% of the foil placement). This method of wrapping is most optimal and will result in the bales being wrapped 4 times in each location. The bale cover will be tight and durable. Depending on the material to be wrapped, the number of film layers can be increased to ensure adequate strength and tightness of the coating and achieve satisfactory silage effects.

ADVICE

Wrapping during rain is not recommended due to the deterioration of the quality of the adhesive applied to the film, which reduces the strength and tightness of the film.

When wrapping bales with a different size, recalculate the minimum number of revolutions needed to wrap the bale.

When wrapping the first bale, count the number of revolutions of the table to wrap the bale completely. Multiply the number of revolutions by 2 (for 4 layers) and increase the result by 1. The final result is the required number of revolutions of the table to wrap the bale in 4 layers (2+2 system).

Increase the number of layers for:

- poorly formed or under compressed bales
- the bale material is too dry,
- the bale material contains a large number of hard fibres.

4.6 UNLOADING OF THE BALE

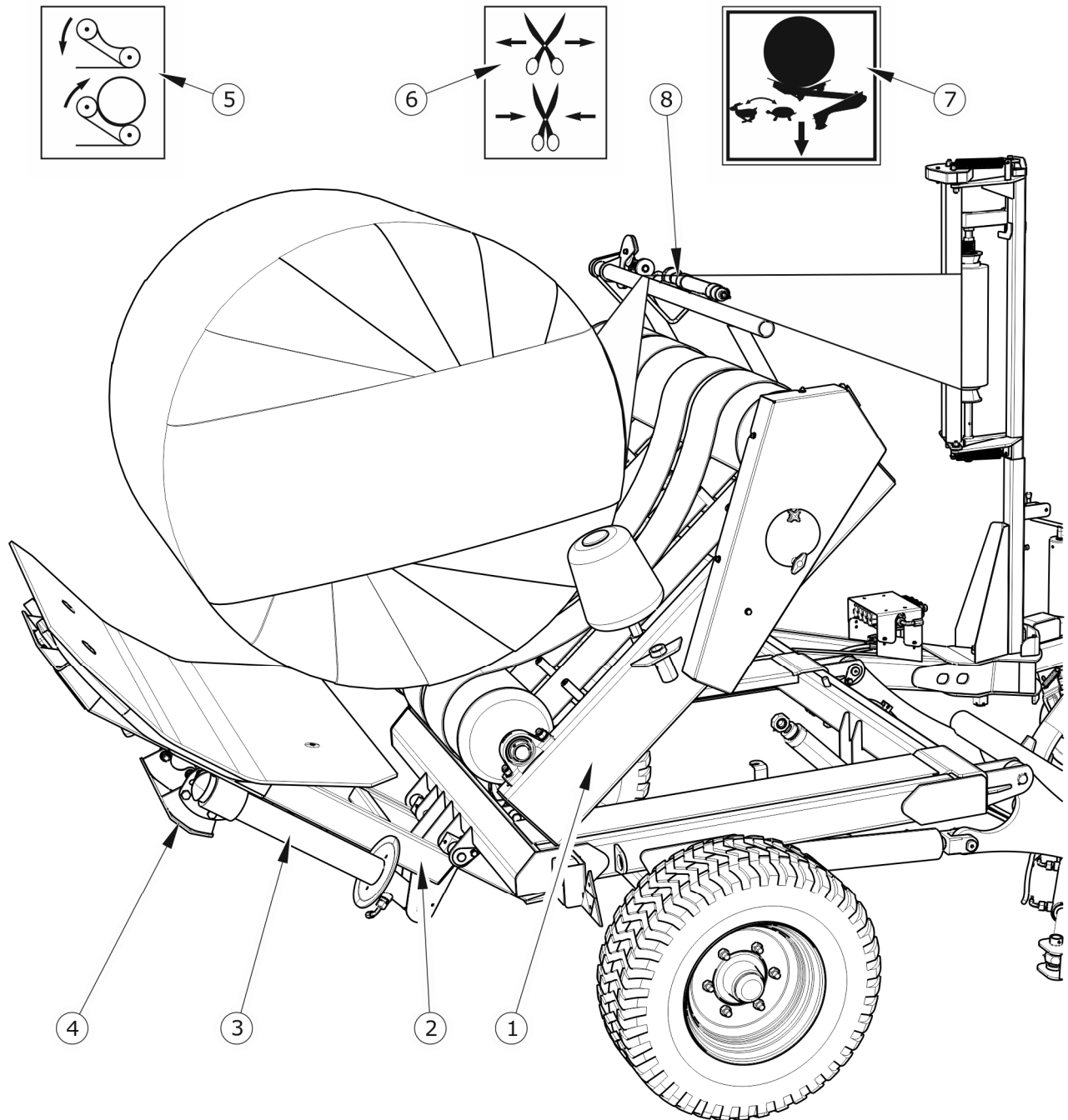

FIGURE 4.10 Correct setting of the unloading wrapper

(1) turntable with tilting frame, (2) unloading arm, (3) side tipping arm, (4) skid, (5) (6) (7) information stickers, (8) cutting system

- ➔ Set the unloading mechanism to the selected unloading mode.
 - ⇒ In figure (4.10) the side tipping arm (3) is set in the position of unloading the bale to the rear.
- ➔ Make sure that there are no bystanders in the unloading area.

- ➔ Position the turntable so that the cutting system is in front of the wrapper and the table rollers are perpendicular to the frame rails of the wrapper.
- ➔ Start table tipping.
 - ⇒ The tipping is controlled by means of a lever marked with an information sticker (5).
- ➔ The unloading arm will be raised first, only in the second step will the turntable start to be raised. First, the unloading arm of the unloading mechanism will be raised, only in the second stage will the turntable be raised.
- ➔ The foil will stretch and will fit between the pressure elements of the cutting system (8).
- ➔ The bale will roll on the unloading table automatically as the turntable is raised.
- ➔ Lower the turntable.
 - ⇒ The unloading arm will drop earlier than the turntable.
- ➔ Place the turntable in the position to load the bale.

DANGER

Unloading of a wrapped bale can only be done when there are no bystanders near the wrapper. A rolling bale can cause an accident.

Take special care when unloading, ensure proper visibility of the work area.

Working at night or in poor visibility conditions increases the risk of an accident.

When unloading a bale, the drawbar eye and the tractor's hitch are subjected to a high vertical load.

The swing frame should automatically lower under the weight of the wrapped bale. The rate of drop shall be set by means of the flow control in such a way that the downward movement is smooth. The unloading arm must not fall at high speed because of the possibility of damage. The regulation principle is presented in figure (4.11).

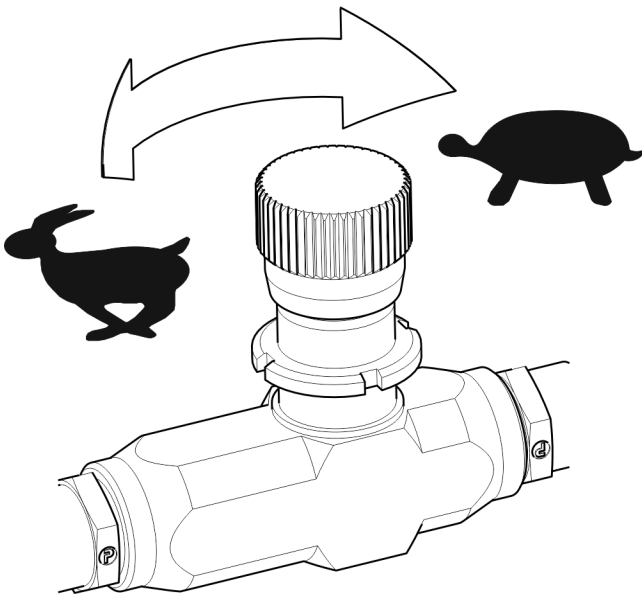

FIGURE 4.11 *Flow regulator*

When the wrapped bale is relatively light, it may happen that the turntable starts to fall earlier than the arm of the unloading mechanism. Adjust the table drop rate using the second hydraulic flow regulator. Normally, the regulator should be fully open (the regulator knob is fully open). If the oil flow is set correctly, the unloading frame will drop first and then the turntable will drop.

When unloading the bale to the side, the lateral tipping paw is pointing vertically. When driving, there is a danger that the system will get your foot on the ground, so it

is necessary to raise the tilt frame slightly to a position where the tipping mechanism will not hook on the ground and the entire system will not prevent the bale from wrapping.



CAUTION

The bale must only be unloaded when the wrapper is stopped.

4.7 DRIVING ON PUBLIC ROADS

To prepare the wrapper for road travel:

- Raise the load arm (1). - Figure 4.12
- Lift the unloading frame (2).
- Fit a triangular plate distinguishing slow moving vehicles (3).
- Fold the drawbar (4) into the DRIVE position.
- Make sure that the parking stand (5) is fully raised.
- Check that the cable and the electrical jumper wire are connected correctly.
- Disconnect and secure the wrap counter cable.
- Move the support with the control levers (6) into the holder mounted on the wrapper mast.

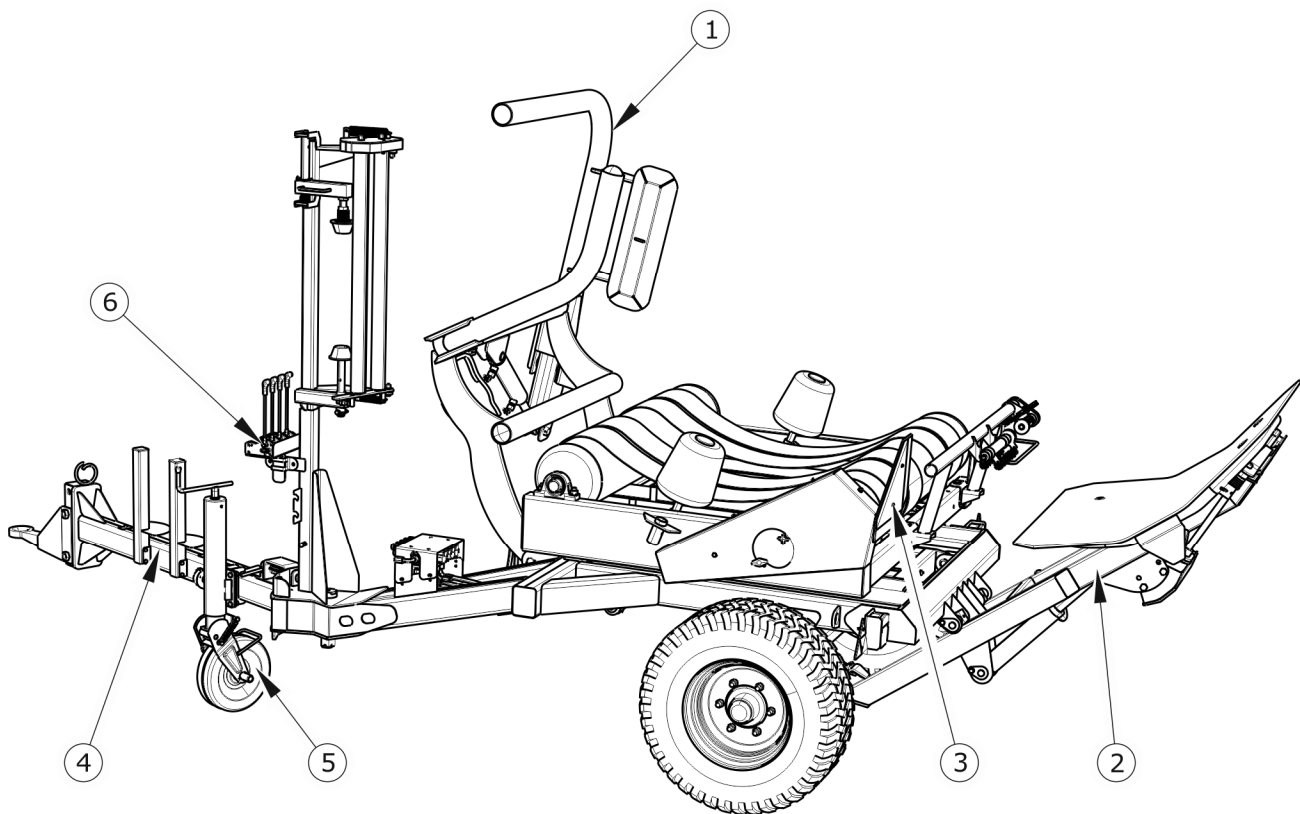

FIGURE 4.12 *To prepare the wrapper for road travel:*

(1) loading arm, (2) unloading mechanism frame, (3) slow-moving vehicle sign, (4) drawbar, (5) parking support, (6) bracket with control levers

When drive comply with traffic regulations, be prudent and considerate. The most important guidelines for steering a tractor with a trailer attached are presented below.

- Before moving off make sure that there are no bystanders, especially children, near the wrapper and tractor. Ensure proper visibility.
- Vertical load carried by the wrapper drawbar eye affects the steering of the agricultural tractor.
- Do not carry any load on the wrapper, including people and bales, when driving on public roads. The wrapper is not suitable for transport.
- Before traveling on public roads, the wrapper must be cleaned of debris from the operation of the device, e.g., film, hay, straw, etc. which can cause road pollution.
- The permissible design speed (30 km/h) and the speed resulting from the road traffic regulations must not be exceeded. The speed of travel should be adapted to road conditions and other conditions.

- In the event of a machine or tractor breakdown, stop at the side of the road without endangering other road users and mark the stopping place in accordance with traffic regulations.
- When travelling on public roads, the wrapper must be marked with a slow-moving vehicle warning sign located in the handle of cutting unit.
- The tractor operator is required to be equipped with an approved warning reflective triangle.
- While driving, obey the rules of the road, signal the change of direction by means of direction indicators, keep clean and take care of the technical condition of the lighting and signalling installation. Damaged or lost lighting and signalling components must be repaired or replaced immediately.
- Avoid ruts, depressions, ditches, or driving along roadside slopes. Driving across such obstacles can cause the wrapper and tractor to tilt suddenly. Driving near the edges of ditches or canals is dangerous due to the risk of landslides under the wheels of vehicles.
- The travel speed should be reduced sufficiently in advance of driving to curves, when driving on uneven or sloping terrain.
- When driving, avoid sharp turns, especially on slopes.
- It should be remembered that the braking distance of the set increases significantly with increasing speed.
- In the event of severe ground irregularities, lower the unloading arm slightly while driving so that the end of the frame does not hook on the ground.
- Control the behaviour of the wrapper when driving on uneven terrain and adjust the speed to terrain and road conditions.

4.8 USE OF TIRES

- When working with tires, the wrapper should be secured against rolling by placing wedges or other elements without sharp edges under the wheels. The wheel can be dismantled only when the wrapper is not loaded.
- Repair work on wheels or tires should be carried out by persons trained and authorized to do so. These works should be carried out using appropriately selected tools.

- Nut tightness should be checked after the first use of the wrapper, after the first day of operation and then every 6 months of use or after traveling 25,000 km, whichever comes first. In the event of intensive more, check the nut tightening at least every 10,000 kilometres. Each time, the inspection activities should be repeated if the wrapper wheel has been disassembled.
- Regularly check and maintain proper tire pressure as recommended in the instructions (especially after a long break).
- Tire pressure should also be checked during all-day intensive work. It should be taken into account that an increase in tire temperature can increase the pressure by up to 1 bar.
- Never reduce pressure by venting if it increases due to temperature.
- Tire valves should be protected with caps to avoid penetration of dirt.
- Do not exceed the maximum wrapper speed.
- During the whole day cycle, take a minimum of one hour break at noon.
- Observe 30 minutes breaks for cooling the tires after driving 75 km or after 150 minutes of continuous driving, whichever comes first.
- Avoid damaged surfaces, sudden and variable manoeuvres, and high speeds when turning.

4.9 WRAP COUNTER (L01, L02)

4.9.1 THE DESIGN AND PRINCIPLE OF THE WRAP COUNTER WORKS

The counter is an electronic device designed to count the wraps of a bale. The set consists of a programmable counter located in a plastic housing and a rotation sensor, connected by a wire and a multi-pin connector. The sensor mounted on the stationary part of the wrapper design works with a permanent magnet placed on turntable and transmits electrical signals to the counter system. Each one full turn of the wrapped bale is counted and shown on the counter display. After counting the number of wraps programmed by the user, the counter signals the end of the wrapping with a blinking and an audible signal (only for counter L02).

As standard, the wrapper is equipped with the counter L01, which can be programmed for 16 or 24 wraps. The L02 counter (optional equipment, as an alternative to the L01 counter) can be programmed in the range of 10 to 49 wraps.

The L01 meter is powered by connecting a 9V battery. The L02 is supplied with 12V voltage via the supplied cable, connected to the cigarette lighter socket.

4.9.2 OPERATION OF THE COUNTER

The counter can be installed in the tractor in any position so that the display is clearly visible. The operating area of the meter should guarantee its safe use, in particular it should protect against excessive shocks, impacts on the tractor structure and, in particular, against the meter falling on hard ground, which can cause permanent damage. Please note that the meter housing is not watertight.

CAUTION



The meter should be protected from moisture, chemicals, rain, frost, high temperature and strong sunlight.

Press the button only with your finger tip. Do not press the button with your fingernail or any hard object, as this will damage the elastic membrane.

4.10 OPERATION OF COUNTER L01

4.10.1 SWITCHING ON AND OFF AND PROGRAMMING OF THE COUNTER

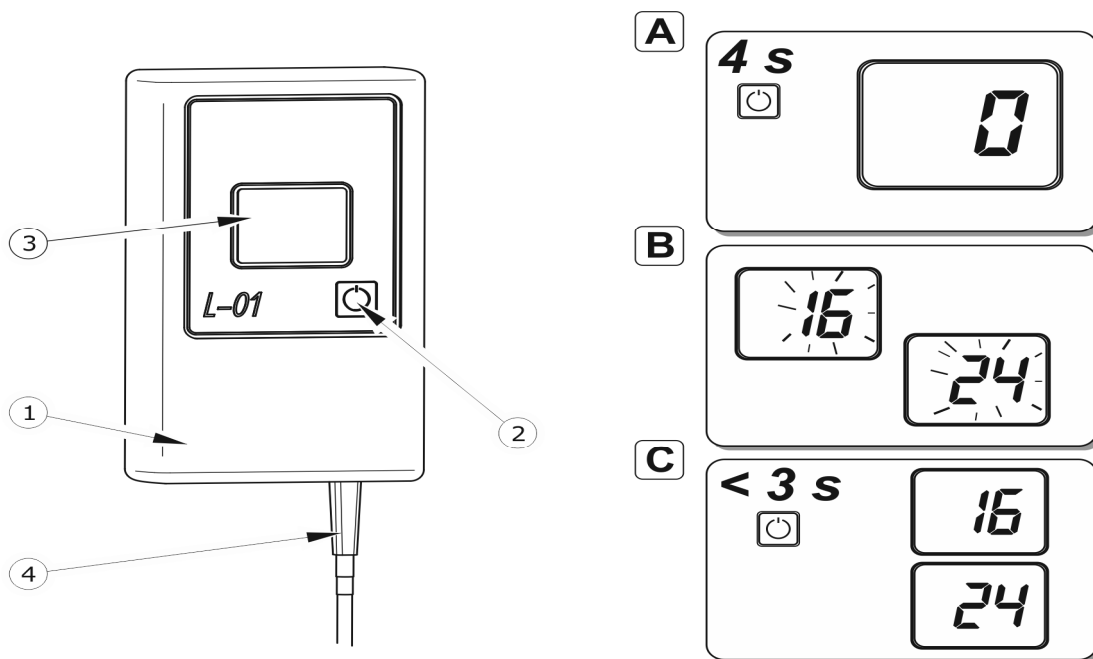

FIGURE 4.13 To program the wrap counter

(1) L01 counter, (2) button, (3) display, (4) connection cable, (A), (B), (C) counter operation sequences

- ➔ Press the button (1) for a moment - figure (4.13).
 - ⇒ After approx. 4 seconds, the counter display will show the number 0 - sequence (A).
- ➔ Press the button again and hold it until the display shows 16 or 24 - last programmed counter-sequence (B).
- ➔ Release the button, the display stops blinking.
- ➔ Press the button again until the desired counter setting is obtained.
 - ⇒ Each time you press the button, the setting changes alternately. Only 2 work positions are available: 16 and 24 wraps. The time between each press should not exceed 3 seconds.
- ➔ To store the number of wraps selected, set the desired value and wait until the number 0 appears on the display. The counter is ready for operation.

The programmed number of wraps is stored by the counter until the counter is reprogrammed or until the battery is removed from the counter. Turning off the counter does not change the programmed number of wraps. The counter switches off automatically after approximately 6 minutes of non-use, i.e., without pulses from the sensor and without pressing the button.

4.10.2 WORKING WITH THE COUNTER IN COUNTING MODE

The counter in count mode shows the currently counted number of wraps on the display. The counter can be reset at any time by pressing the button. After each turn of the bale, the counter increases the display by one. After the programmed number of wraps has been counted, the counter display starts flashing, which at the same time indicates that the bale wrapping is complete. Before wrapping the next bale, the counter must be reset. To do this, press the button until 0 appears on the display, then release the button. If you hold down the button for longer, the timer will go into programming mode.

The counter remembers the number of wraps until it has been reset even after the timer has switched off. When re-engaged, the display shows the last value for the number of wraps of the bale.

4.11 OPERATION OF COUNTER L02

4.11.1 CONSTRUCTION AND PRINCIPLE OF OPERATION OF THE L02 COUNTER

TABLE 4.1 *Meaning of the pictograms of counter L02*

Pictogram	Name	DESCRIPTION
	Function key F1	Field selection (meadow).
	Function key F2	Selection of counter indications.
	Function key CLEAR	Turn the counter on/off. Confirm programming.
1 2 3	FIELD	Selected field information (meadow)
	BALE	Information about the number of bales wrapped.
	TIME	Total wrapping time information.
	PERFORMANCE	Wrapping capacity information (number of bales wrapped per hour)
	CAUTION	Warnings and alarms
	WRAPPING	Information about the programmed and current number of wraps.

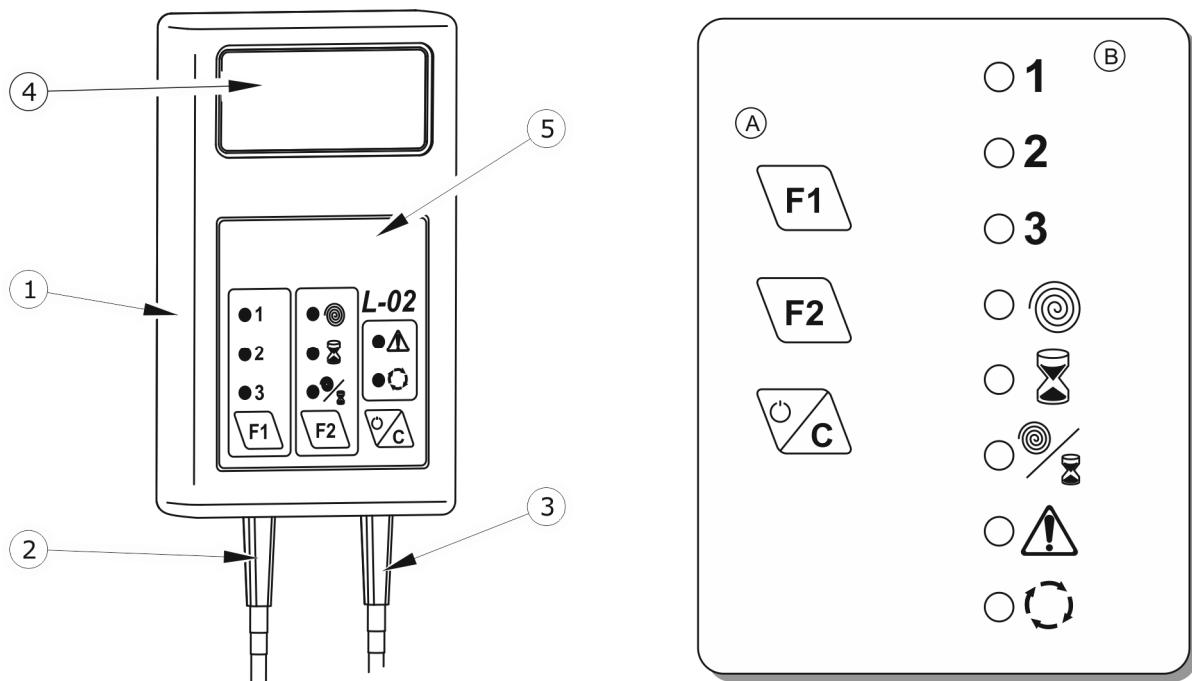

FIGURE 4.14 *Operation of counter L02*

(1) L02 counter, (2) power cable, (3) rotation sensor cable, (4) display, (A) function buttons, (B) signalling LEDs

4.11.2 SWITCHING ON AND OFF

SWITCHING ON OF THE COUNTER

- ➔ Connect the power plug to the cigarette lighter socket.
 - ⇒ The red LED on the counter display blinks when the connection is correct.
- ➔ Connect the rotation sensor cable.
- ➔ Switch on the counter while holding the clear button figure (4.14).

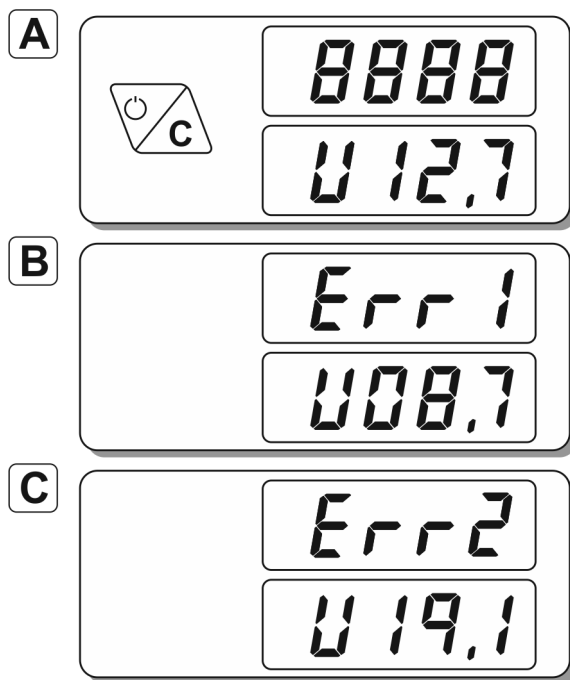

FIGURE 4.15 *Display indication in engagement mode*

(A) counter working, ready to run, (B) error, supply voltage too low, (C) error, supply voltage too high

signal and a blinking red LED (caution).

The voltage of the supply is too high and Err2 is displayed alternately in the voltage value e.g., U19.1 (19.1 V) This is also indicated by an intermittent audible signal and a blinking red LED (caution).

After a positive test, the meter is ready for operation and its settings are identical to the previous shutdown.

- ➔ Check the display.

⇒ Each time the counter is switched on, the counter tests the display and checks the supply voltage, the counter display shows 8888 and all the decimal points and LEDs illuminate, and the buzzer sounds. Then the counter supply voltage, example U12.7 (indicates 12.7 V), is displayed. Any other status indicates that the counter has been damaged.

If the supply voltage is too low, Err1 will be displayed alternately in the voltage value e.g., U08.7 (8.7 V voltage) This is also indicated by an intermittent audible

SWITCHING OFF OF THE COUNTER

- ➔ Press the CLEAR button for approximately 3 seconds.
 - ⇒ A blinking red dot appears on the display.
- ➔ Disconnect the supply hose.
- ➔ Disconnect the sensor wire.

4.11.3 TO PROGRAM THE WRAPS NUMBER

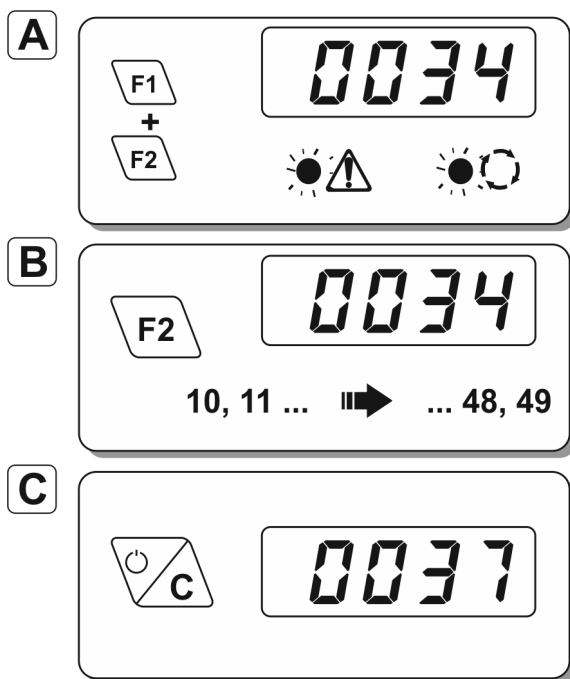

FIGURE 4.16 Counter programming sequences

(A) start programming the counter, (B) set a new number of wraps, (C) save a new number of wraps

PROGRAMMING

- ➔ Press buttons F1 and F2 simultaneously – item (a), figure (4.16).
- ➔ The last setting appears on the display, the change mode for the number of wraps is indicated by the red CAUTION LED and the green WRAPPING LED.
- ➔ Use F2 key to change the number of wraps (range 10 - 49) to position (B).
- ➔ Confirm the new setting by pressing the CLEAR button - position (C).
- ➔ The counter enters the operating mode with the new setting.

WRAPPING OF THE BALE

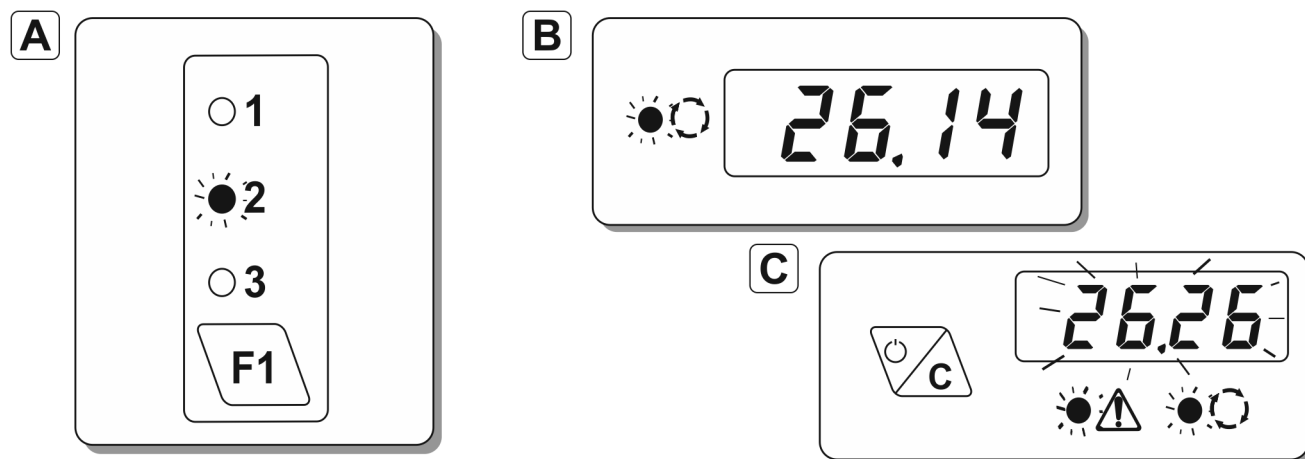

FIGURE 4.17 *Wrapping of the bale*

(A) field selection, (B) counter display during wrapping, (C) wrap completion

DESCRIPTION OF ACTIVITIES

- ➔ Select the field/meadow (1, 2 or 3) where the bale will be wrapped. Selection of the field is made with the F1 button - position (A), figure (4.17).
- ➔ Program the number of wraps (if necessary).
- ➔ Start wrapping the bale.
 - ⇒ The counter will automatically switch to the wrap display options when a pulse is received from the wrapper sensor. An example of the counter is shown in the figure in position (B). The first part means that 26 wraps have been programmed, the second part means that the bale has been wrapped 14 times at this time.
- ➔ When the bale is wrapped (the set number of wraps is exceeded), the counter display flashes alternately with the CAUTION LED, and the wrapping is also indicated by an intermittent audible signal at position (C).
- ➔ After unloading the bale, clear the counter to prepare for wrapping the next bale. To do this, press the clear button until the display shows the BALE count - the BALE LED is on, the CAUTION LED is off.
 - ⇒ The counter is now ready to count the wraps of the next bale.

4.11.4 SELECTION OF THE DISPLAY

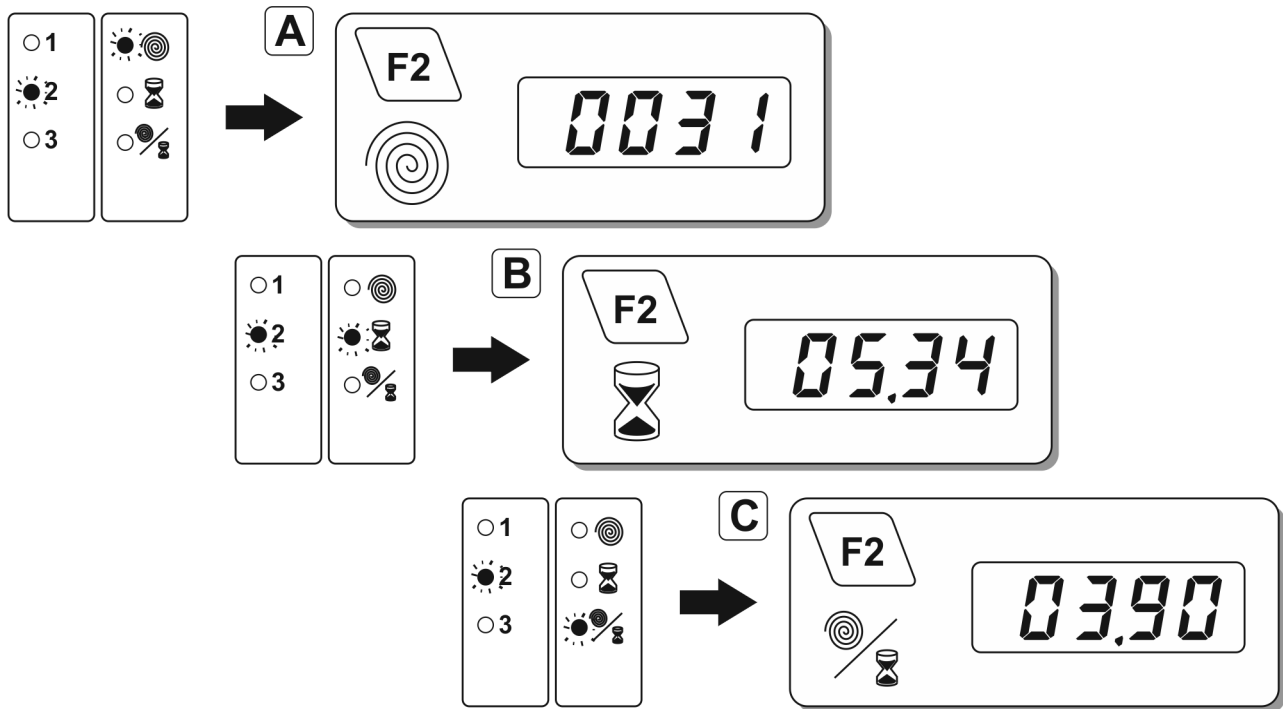

FIGURE 4.18 Readings of parameters

(A) bale count reading, (B) average time reading, (C) yield reading

READINGS OF PARAMETERS

- ➔ Press F1 to select the field (meadow) for which you want to read the wrapper parameters.
- ➔ Press F2 to select the counter display.
 - ⇒ Bale count reading - position (a) - figure (4.15) indicates that 31 bales have been wrapped in field 2.
 - ⇒ Reading working times - position (B), indicates that 5 hours and 34 minutes of wrapping took place in field 2.
 - ⇒ Yield reading - position (C), indicates an average of 3.9 bales per hour in field 2

4.11.5 CLEARING OF THE COUNTER

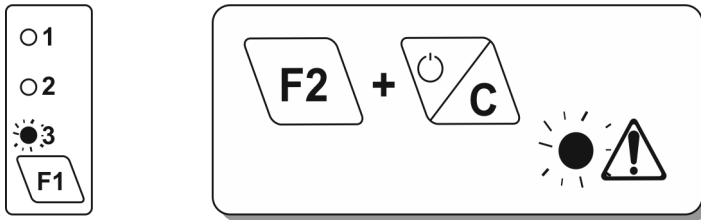

FIGURE 4.19 Counter clearing sequences

CLEARING OF THE COUNTER

- ➔ Press F1 to select the field for which you want to reset the parameters (stored indications).
- ➔ Press and hold the F2 and CLEAR buttons at the same time.

⇒ The CAUTION LED lights up and a continuous beep sounds to indicate that the deletion is cleared.

- ➔ Release both buttons when the beeper stops.

CHAPTER

5

TECHNICAL SUPPORT

5.1 PRELIMINARY INFORMATION

When using the wrapper, it is necessary to constantly check the technical condition and perform maintenance procedures that will allow the machine to be kept in good technical condition. Therefore, the wrapper user is obliged to perform all maintenance and adjustment activities specified by the Manufacturer.

Repairs during the warranty period may only be carried out by authorized service centres.

This chapter describes in detail the procedures and scope of activities that the user can perform on his own. In the event of unauthorized repairs, changes to factory settings or activities that were not taken into account as possible for the wrapper operator to perform this user loses the warranty.

5.2 DRIVING AXLE SERVICE

5.2.1 PRELIMINARY INFORMATION

Work related to the repair, replacement or regeneration of driving axle elements should be entrusted to specialized workshops that have the appropriate technologies and qualifications to perform this type of work.

User responsibilities include only:

- checking and adjusting the play of the axle bearings,
- wheel assembly and disassembly, checking wheel tightness,
- air pressure control, assessment of the technical condition of wheels and tires.

Activities related to:

- grease replacement in axle bearings axle,
- replacement of bearings, hub seals,

they can be performed by specialized workshops.

5.2.2 CHECKING THE CLEARANCE OF THE AXLE BEARINGS

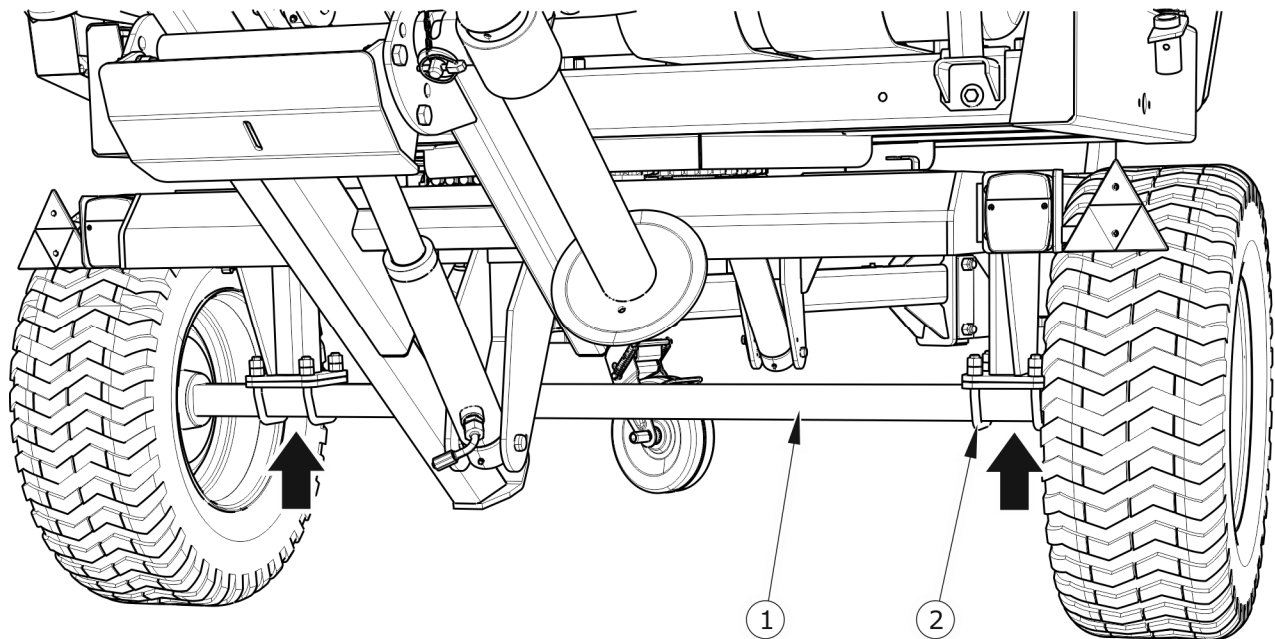

FIGURE 5.1

FIGURE 5.2 *Hoist support point*

(1) driving axle, (2) U-bolt

PREPARATORY ACTIVITIES

- ➔ Hitch a wrapper to the tractor, immobilize tractor with parking brake.
- ➔ Place the tractor and wrapper on firm and level ground.
- ➔ Position the tractor for straight-ahead travel.
- ➔ Place safety wedges under the wrapper wheel. Ensure that the machine will not roll during inspection.
- ➔ Raise the wheel (located on the opposite side of the placed wedges).
 - ⇒ The jack should be placed between U bolts (2) - figure (5.1) securing the axle (1) to the lower frame. Recommended support point is marked with an arrow. The jack must be suited to the wrapper weight.

CHECKING THE CLEARANCE OF THE AXLE BEARINGS

- ➔ Turn the wheel slowly in two directions to check if the movement is smooth and the wheel rotates without excessive resistance and jams.
- ➔ Turn the wheel so that it rotates very quickly, check that the bearing does not make any unusual sounds.

- ➔ While holding the wheel up and down, try to feel the clearance.
 - ⇒ You can use the lever under the wheel, resting the other end on the ground.
- ➔ Repeat the checks for the other wheel.

ADVICE



Damaged hub cover or lack thereof will cause the penetration of dirt and moisture into the hub, which will result in much faster wear of bearings and hub seals.

Bearing life depends on wrapper operating conditions, load, vehicle speed and lubrication conditions.

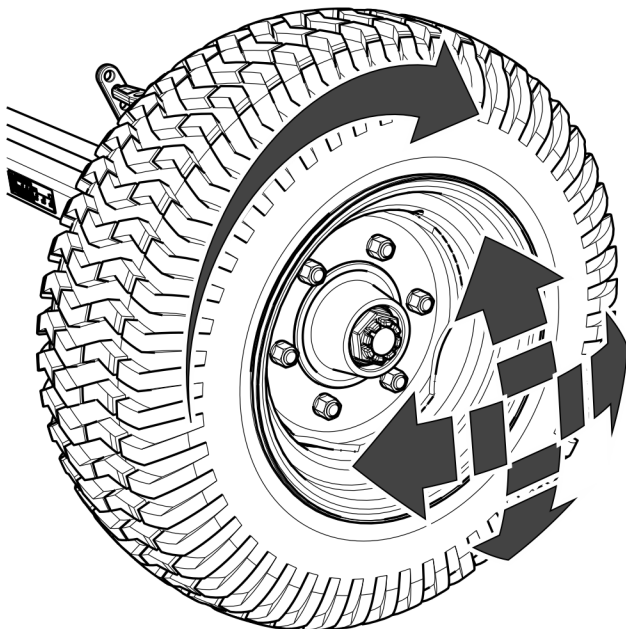

FIGURE 5.3 Clearance inspection

If looseness is felt, adjust the bearings. Unnatural sounds coming from the bearing may be symptoms of excessive wear, dirt or damage. In this case, the bearing together with the sealing rings should be replaced or cleaned and regreased.

Check the technical condition of the hub cover, replace if necessary. Bearing looseness can be checked only when the wrapper is connected to the tractor. The machine cannot be loaded.

DANGER



Before starting work, read the instructions for the lift and follow the manufacturer's instructions.

The lift must stand firmly against the ground and the axle.

Ensure that the wrapper will not roll when checking the looseness of the axle bearings.

OVERVIEW

Checking the clearance of the axle bearings:



- *after the first use of the wrapper,*
- *after the first trip with a load,*
- *every 6 months of use or every 25,000 kilometres*
- *before intensive use of the wrapper,*

If the wrapper is to be used intensively, check the tightness at least once every 10 000 kilometres.

5.2.3 ADJUSTING THE CLEARANCE OF THE AXLE BEARINGS**THE SCOPE OF SERVICE ACTIVITIES**

FIGURE 5.4 *Adjustment of axle bearings*

(1) hub cover, (2) crown nut, (3) cotter pin

- ➔ Prepare the tractor and wrapper for adjustment activities as described in section 5.2.2.
- ➔ Remove the hub cover (1) – figure (5.3).
- ➔ Remove the cotter pin (3) securing the castellated nut (2).
- ➔ Tighten the castellated nut to remove slack.
- ⇒ The wheel should rotate with slight resistance.

➔ Unscrew the nut (not less than 1/3 turn) to cover the nearest nut groove with a hole in the axle pin. The wheel should rotate without excessive resistance

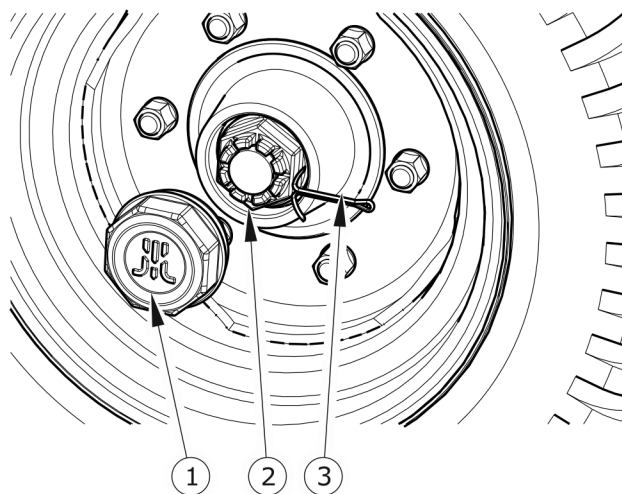
⇒ The nut must not be too tight. It is not recommended to apply too much pressure due to deterioration of bearing operating conditions.

➔ Secure the castellated nut with a cotter pin and mount the hub cover.

➔ Gently tap the hub with a rubber or wooden hammer.

The wheel should rotate smoothly, without any jams or noticeable resistance. Adjustment of bearing looseness can only be carried out when the wrapper is connected to the tractor and the wrapper is not loaded.



ADVICE

If the wheel is removed, the bearing clearance is easier to check and adjust.

5.2.4 WHEEL ASSEMBLY AND DISASSEMBLY, CHECKING NUT TIGHTNESS

WHEEL DISASSEMBLY

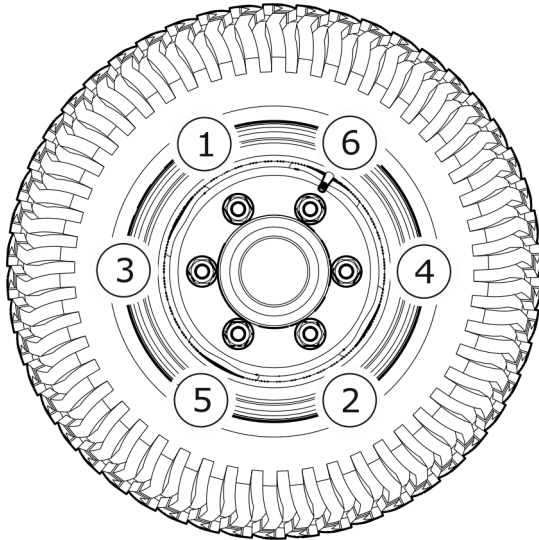

FIGURE 5.5 *The order of the nuts unscrewing and tightening*

- ➔ Chock the wheel that will not be removed.
- ➔ Ensure that the wrapper is properly secured and will not move during wheel dismantling.
- ➔ Loosen the wheel nuts according to the order given in figure (5.4).
- ➔ Place the jack and raise the trailer.
- ➔ Remove the wheel.

WHEEL MOUNTING

- ➔ Clean the axle pins and nuts from contamination.
- ➔ Do not lubricate the threads of the nut and stud.
- ➔ Check the condition of the pins and nuts, replace if necessary.
- ➔ Mount the wheel on the hub, tighten the nuts so that the rim fits snugly to the hub.
- ➔ Lower the wrapper, tighten the nuts according to the recommended torque and the given order.

TIGHTENING THE NUTS

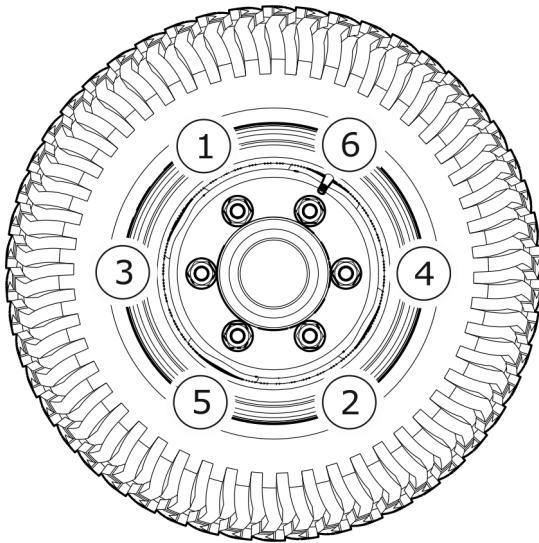



FIGURE 5.6 TIGHTENING TORQUE

(L) key length, (F) user weight

The nuts should be tightened gradually diagonally (in several stages until the required tightening torque is achieved), using a torque wrench. In the absence of a torque wrench, you can use a regular wrench. The wrench arm (L), figure (5.5), should be selected according to the weight of the person (F) tightening the nut. It should be remembered that this method of tightening is not as accurate as when using a torque wrench. The highest tightening accuracy is obtained with a torque wrench. Before starting work, make

sure that the correct torque value is set.

CAUTION



Wheel nuts must not be tightened with impact wrenches, due to the danger of exceeding the permissible tightening torque, which may result in breaking the connection thread or breaking the hub pin.

ADVICE



Wheel nuts should be tightened to 270 Nm - M18x1.5 nuts.

TABLE 5.1 Key arm selection

TIGHTENING TORQUE	WHEEL BODY WEIGHT (F)	ARM LENGTH (L)
[Nm]	[kg]	[m]
270	90	0.30
	77	0.35
	67	0.40
	60	0.45

OVERVIEW

Checking the clearance of the axle bearings:



- *after the first use of the wrapper,*
- *after the first trip with a load,*
- *every 6 months of use or every 25,000 kilometres*
- *before intensive use of the wrapper,*

If the wrapper is to be used intensively, check the tightness at least once every 10 000 kilometres. All operations must be carried out again if

5.2.5 AIR PRESSURE CONTROL, ASSESSMENT OF TECHNICAL CONDITION OF TIRES AND STEEL WHEELS

The tire pressure should be checked after each wheel change and at least once a month. In the event of intensive use, it is recommended to check the air pressure more often. The wrapper must be unloaded at this time. Checking should be carried out before driving, when the tires are not warm, or after a long standstill of the machine.

**ADVICE**

The value of the tire pressure is specified on the information sticker, placed on the rim or frame, above the wrapper wheel.

**DANGER**

Damaged tires or wheels can be the cause of a serious accident.

When checking pressure, pay attention to the technical condition of rims and tires. Look carefully at the side surfaces of the tires and check the tread condition. In the event of mechanical damage, consult your nearest tire service centre and ensure that your tire defect is eligible for replacement. Rims should be checked for deformation, material cracks, weld cracks, corrosion, especially around welds and contact with the tire. Technical condition and appropriate maintenance of wheels significantly extends the life of these elements and ensures an appropriate level of safety for wrapper users.

OVERVIEW

Pressure control and visual inspection of steel wheels:

- • every 1 month of use,
- • every week in case of intensive use,
- • in case of emergency.

5.3 HYDRAULIC SYSTEM OPERATION

5.3.1 PRELIMINARY INFORMATION

Work related to the repair, replacement or regeneration of hydraulic system components (cylinders, valves, etc.) should be entrusted to specialized workshops that have the appropriate technologies and qualifications to perform this type of work.

The user's obligations related to the operation of the hydraulic system include only:

- checking system tightness and visual inspection of the system,
- checking the technical condition of the hydraulic connectors.

**DANGER**

It is forbidden to use the wrapper with inefficient hydraulic system.

5.3.2 CHECKING THE THIGHTNESS OF THE HYDRAULIC SYSTEM

THE SCOPE OF SERVICE ACTIVITIES

- ➔ Hitch the wrapper to tractor.
- ➔ Connect hydraulic system hoses according to the instructions in the manual.
- ➔ Clean connectors and hydraulic cylinders.
- ➔ Operate all hydraulic systems one at a time.
- ➔ Check hydraulic cylinders and hydraulic lines for leaks.

In the event of oiling on the hydraulic cylinder body, the nature of the leakage must be checked. When the cylinder is fully extended, check the seal locations. Slight leaks are permissible with symptoms of "sweating", however in the event of noticing leaks in the form

of "droplets" stop using the wrapper until the fault is remedied. If there is a leak at the connections, tighten the connection.

OVERVIEW



Checking for leaks:

- *after the first week of use,*
- *every 12 months of use.*

5.3.3 CHECKING THE TECHNICAL CONDITION OF THE HYDRAULIC CONNECTORS

Hydraulic connectors are technically sound and clean. Each time before connecting, make sure that the sockets in the tractor are maintained in good condition. The tractor's and wrapper's hydraulic systems are sensitive to the presence of solid impurities that can cause damage to precise components of the installation (impurities can cause stuck hydraulic valves, scratch the surface of cylinders, etc.)

OVERVIEW



Checking the hydraulic plugs and sockets:

- *each time the wrapper is connected to the tractor.*

5.3.4 REPLACEMENT OF HYDRAULIC HOSES

Rubber hydraulic hoses should be replaced every 4 years regardless of their technical condition. This operation should be entrusted to specialized workshops.

OVERVIEW



Replacement of hydraulic hoses:

- *Every 4 years.*

5.4 ELECTRICAL SYSTEM SERVICE AND WARNING ELEMENTS

5.4.1 PRELIMINARY INFORMATION

Work related to the repair, replacement or regeneration of electrical installation components should be entrusted to specialized workshops that have appropriate technologies and qualifications to perform this type of work.

User responsibilities include only:

- technical inspection of the electrical installation and reflectors,
- replacement of bulbs.



CAUTION

Driving with defective lighting installations is prohibited. Damaged lampshades and burned-out bulbs should be replaced immediately before driving off. Lost or damaged reflectors should be replaced with new ones.

THE SCOPE OF SERVICE ACTIVITIES

- ➔ Connect the wrapper to the tractor with a suitable connection lead.
 - ⇒ Make sure the connection cable is OK. Check the connection sockets on the tractor and on the wrapper.
- ➔ Check the completeness, technical condition and correct functioning of the wrapper's lighting.
- ➔ Check the completeness of all reflectors.
- ➔ Check the correct installation of the triangular plate holder for slow moving vehicles.
- ➔ Before travelling on a public road, make sure that the tractor has a reflective warning triangle.



OVERVIEW

*Electrical system check:
each time when connecting the wrapper.*



ADVICE

Before travelling, make sure that all lamps and reflectors are clean.

5.4.2 REPLACEMENT OF BULBS

For a list of the bulbs, see table (5.2). All light lenses are fixed with screws and there is no need to remove the entire lamp or wrapper components.

TABELA 5.1 *List of bulbs*

LAMP	TYPE OF LAMPS	BULB / QUANTITY IN 1 LAMP	NUMBER OF LAMPS
Left rear combination light	W 18U	P21W / 2 pcs. R10W / 1 pc	1
Right rear combination light	W 18U	P21W / 2 pcs. R10W / 1 pc	1

5.5 ADJUSTING OF THE TENSION OF THE TURNTABLE DRIVE CHAIN

PREPARING OF THE WRAPPER

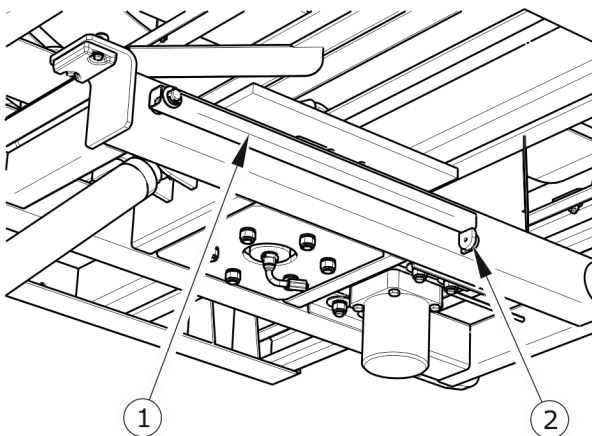

FIGURE 5.7 *Turntable service support*

(1) service support, (2) mounting bolt

- ➔ Hitch the wrapper to tractor.
- ➔ Connect hydraulic system hoses.
- ➔ Lower the load arm.
- ➔ Rotate the turntable in the unloading position.
- ➔ Raise the turntable, unscrew the screw (2) securing the support in the rest position. Support the turntable with the support (1).
- ➔ Switch off the tractor engine, immobilize the tractor with the parking brake.

- ➔ Secure the tractor cab against unauthorized access.

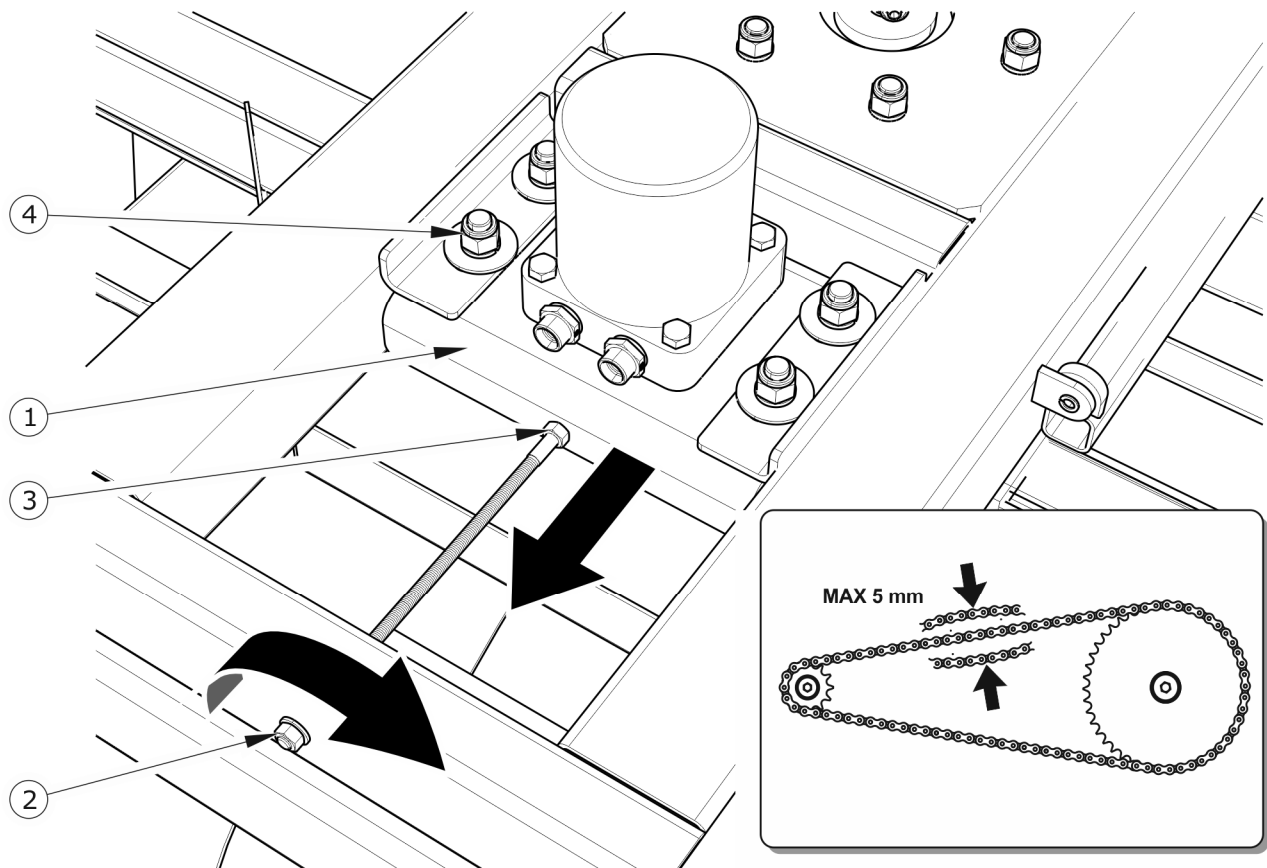

FIGURE 5.8 *Adjusting of the turntable drive chain.*

(1) motor channel section, (2) tensioning screw, (3) lock nut, (4) motor channel section fixing nut

THE SCOPE OF SERVICE ACTIVITIES

- ➔ Loosen the 4 nuts (4) securing the motor profile (1) - Figure (5.7).
- ➔ Loosen and remove the locknut (3).
- ➔ Adjust the chain tension with the tension screw (2).
 - ⇒ Turning the screw clockwise increases the voltage on the drive chain, the motor channel (1) moves in the direction of the arrow.
- ➔ Check chain deflection.
- ➔ The chain play, measured at half length, should be approximately 5 mm.
- ➔ Install the motor channel with the nuts (4), and tighten the locknut (3).
- ➔ Fold the support, lower the turntable.
- ➔ Perform a test start by starting the table drive.

The turntable should move smoothly, without jams and a large abnormal noise of the transmission. If the symptoms described above are present, check the chain tension and check the mounting of the hydraulic motor channel.

OVERVIEW



On a newly purchased wrapper, adjust after the first 15 20 bales have been wrapped and then adjust every 150 bales that have been wrapped.

Chain tension check and/or adjustment should be performed whenever there is a noisy transmission.

Noisy transmission can cause high wear (stretching) of the drive chain, which is normal for this type of drive. In this case, further adjustment will not bring the desired result, the chain should be replaced with a new one.



CAUTION

The adjustment must be checked without load, i.e., when the turntable is not loaded.

5.6 ADJUSTING OF ROLL DRIVE CHAIN TENSION

THE SCOPE OF SERVICE ACTIVITIES

- ➔ Connect the wrapper to the tractor, connect the hydraulic lines.
- ➔ Rotate the table so that the active roller bearings can be easily accessed, Figure (5.8).
- ➔ Switch off the tractor engine, immobilize the tractor with the parking brake. Secure the tractor cab against unauthorized access.
- ➔ Remove the chain guard (6).
- ➔ Check the chain tension at the middle of its length.
 - ⇒ If the deflection of the chain is more than 10 mm, adjustment must be made.

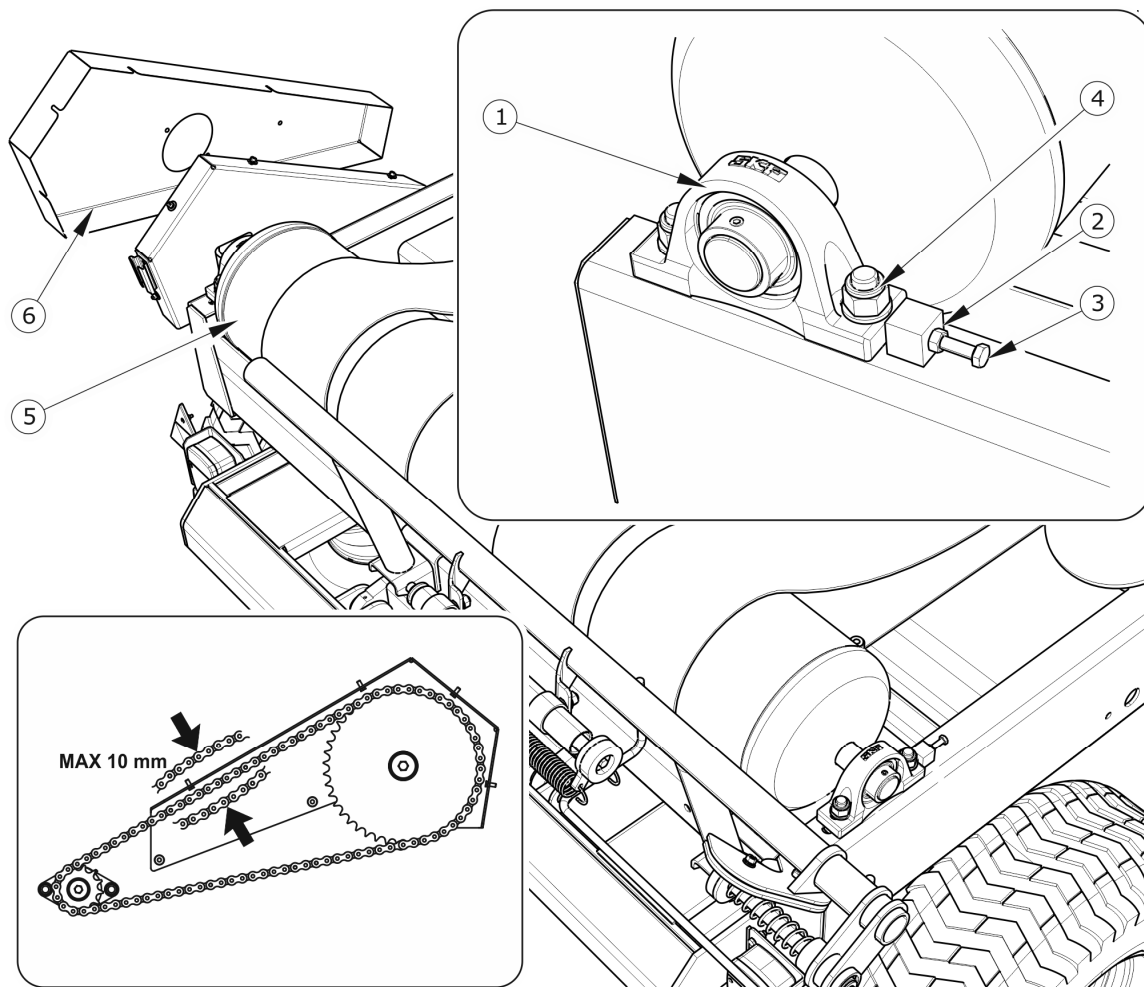

FIGURE 5.9 Adjustment and control of the roller drive chain tension

(1) bearing unit, (2) counter nut, (3) adjusting screw, (4) bearing unit mounting nut, (5) table active roller, (6) gear cover

- ➔ Loosen the 4 nuts (4) securing the 2 active roller bearing units (1).
- ➔ Loosen the 2 lock nuts (2) of the adjusting screws (3).
- ➔ Remove the bearing units by installing the bolt (3) until the required chain tension is achieved.
 - ⇒ Turn each bolt (3) an equal number of times to ensure the required symmetry and parallelism of the rollers.
- ➔ After obtaining the correct tension on the chain, tighten the bearing assembly located on the side of the sprocket, check the position of the roller again and screw the rear bearing assembly.
- ➔ Tighten the lock nuts and install the chain guard.
- ➔ Check the tension of the rubber belts, adjust if necessary.



OVERVIEW

Check the tension of the turntable roller drive chain at the same time as the drive chain tension is checked, and whenever the roller bearings are replaced or the active roller sprocket is replaced.

5.7 ADJUSTING OF THE WRAPPER TO THE FOIL 500

5.7.1 CHANGE THE TRANSMISSION RATIO

The use of a 500 mm wide film requires the wheel (1) – Figure (5.9) with the number of teeth 28 per wheel with the number of teeth 45.

TABELA 5.2 Selection of sprockets and drive chains depending on the width of the film

FILM WIDTH [MM]	NUMBER OF CHAIN LINKS	NUMBER OF GEAR TEETH
500	85+9	45
750	85	28

Due to the different film width, a different rotation speed of the rollers of the turntable is required. When replacing a sprocket with 28 teeth, a drive chain of 85 links is required. When using a gear with a number of teeth 45, it is necessary to use a longer chain, with a number of links 94 (85+9). To the chain of 85 links, which is fitted as standard at the foil 750, extension links must be added, they are included in the machine.

ADJUSTMENT OF THE GEARBOX TO THE 500 MM FOIL

- ➔ Connect the wrapper to the tractor, connect the hydraulic lines.
- ➔ Rotate the table in such a way as to allow easy access to the roller drive chain gear - figure (5.9).
- ➔ Switch off the tractor engine, immobilize the tractor with the parking brake. Secure the tractor cab against unauthorized access.
- ➔ Remove the chain guard (2).
- ➔ Remove the drive chain.
 - ⇒ The chain is equipped with a fire-retardant connection.

- ➔ Loosen the roller bearing mounting nuts, the lock nuts and the bearing adjusting bolts, refer to figure (5.8).
- ➔ Remove the mounting bolt (3). Remove the gear (45 teeth).
 - ⇒ Use a bearing puller of the correct size to remove the wheel. Do not strike the gear with a hammer or other tools.
- ➔ Fit the sprocket with the number of teeth 28, tighten the sprocket.
- ➔ Install the drive chain (85 links).
- ➔ Adjust chain tension.
- ➔ Install the transmission guard.

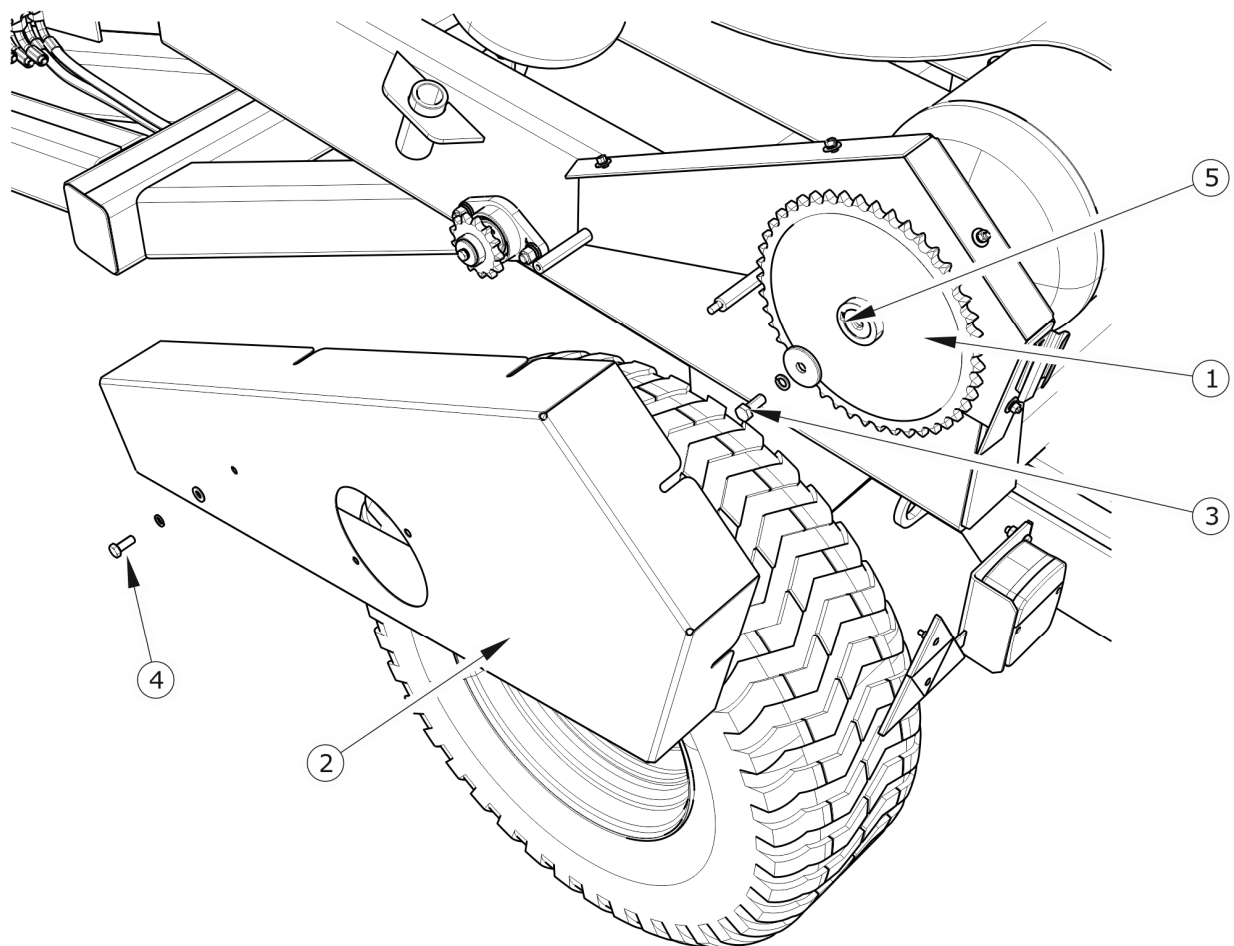

FIGURE 5.10 *Remove the roll drive wheel*

(1) gear wheel, (2) gear cover, (3) gear wheel mounting elements, (4) cover mounting elements, (5) prismatic key

ADJUST THE TRAY FOR TRANSPARENCIES 500 WIDTH

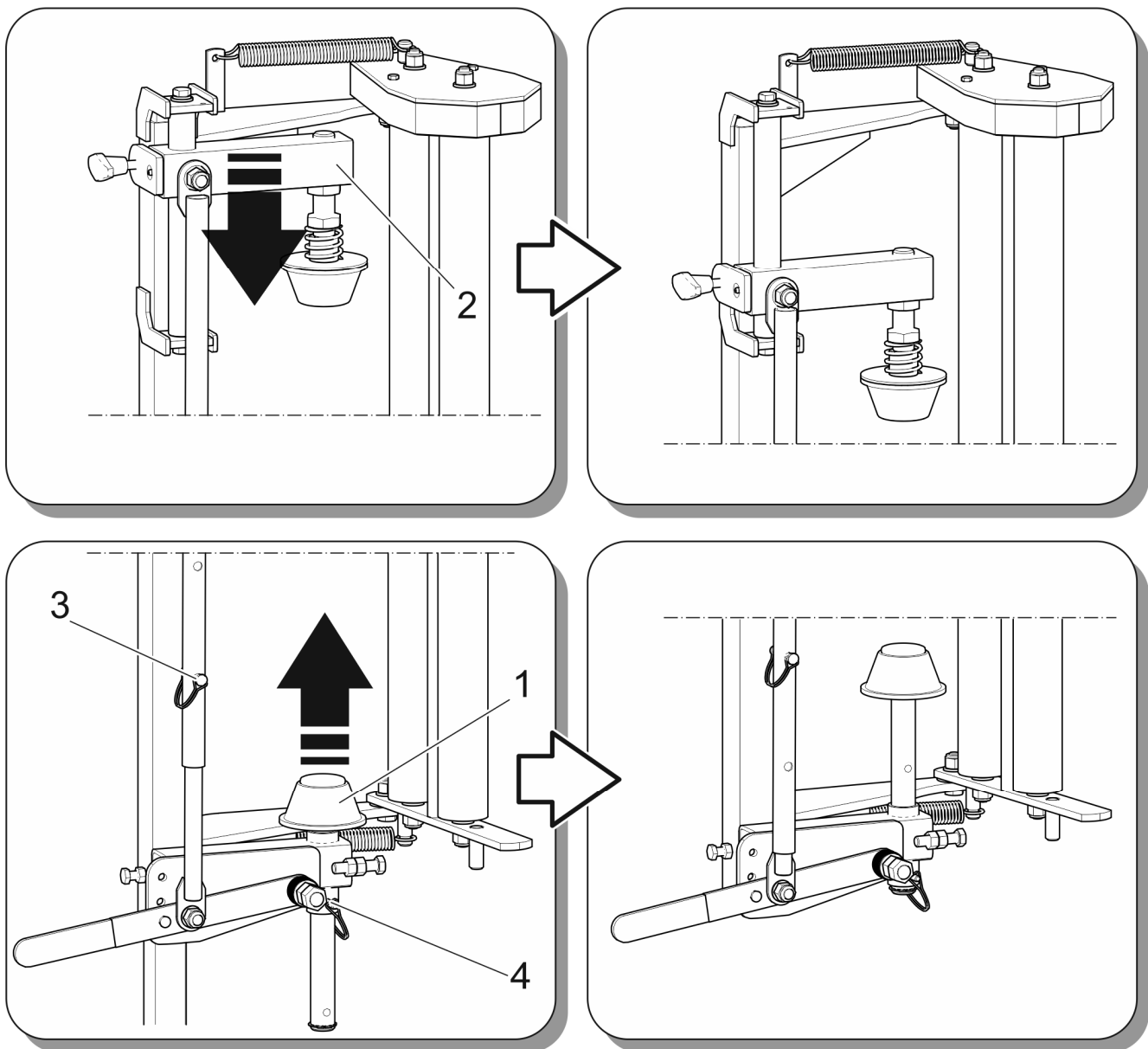

FIGURE 5.11 *Film feeder*

(1) lower support roller, (2) foil pressure plate, (3) clamp pin, (4) lower roll pressure plate pin

- ➔ Immobilize tractor with parking brake. Secure the cab against unauthorized access.
- ➔ Remove the cotter pin (4) – figure (5.10).
- ➔ Raise the lower support roller and secure with the cotter pin (4).
- ➔ Disassemble the cotter pin (3), move the foil pressure lever up and secure it with the cotter pin (3).
- ➔ Loosen the screw (5), lower the pressure lever, tighten the screw.

5.8 LOADING ARM BUMPER ADJUSTMENT

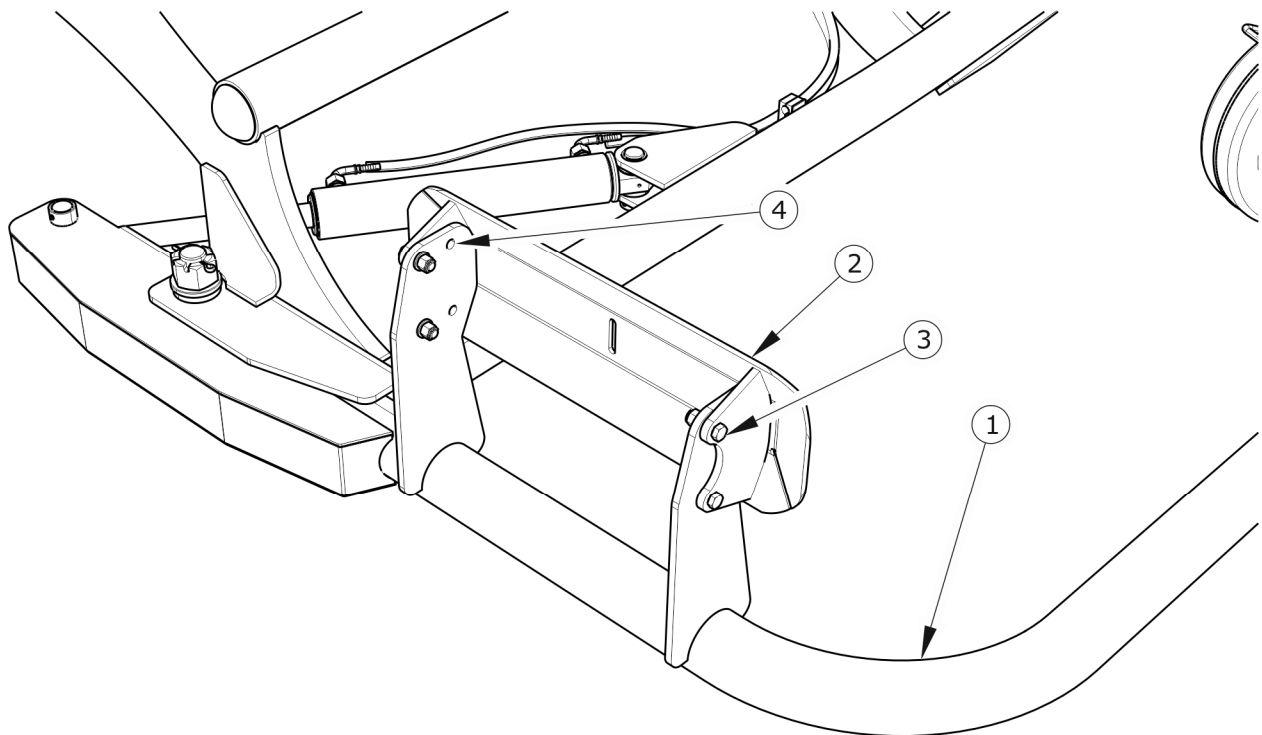

FIGURE 5.12 Loading arm bumper adjusting

(1) gripping arm, (2) bale bumper, (3) screw connection, (4) adjustment holes

The load arm must be adjusted to the size of the bales being compressed. Adjusting the bumper (2) will allow the bale to be loaded correctly on the turntable. When the bale is loaded, the bale must be approximately in the middle of the table length.

THE SCOPE OF SERVICE ACTIVITIES

- ➔ Connect the wrapper to the tractor, connect the hydraulic lines.
- ➔ Lower the load arm to the ground.
- ➔ Turn off the tractor engine, secure the cabin against unauthorized access.
- ➔ Unscrew the screw connections (3).
- ➔ Move the bumper to the desired position.
- ➔ Install the screws and tighten the nut.

5.9 CHANGING OF THE BALE UNLOADING METHOD

The wrapper has the ability to unload the bale in two ways:

- roll the bale behind the wrapper,
- roll the bale sideways to the left-hand side of the wrapper.

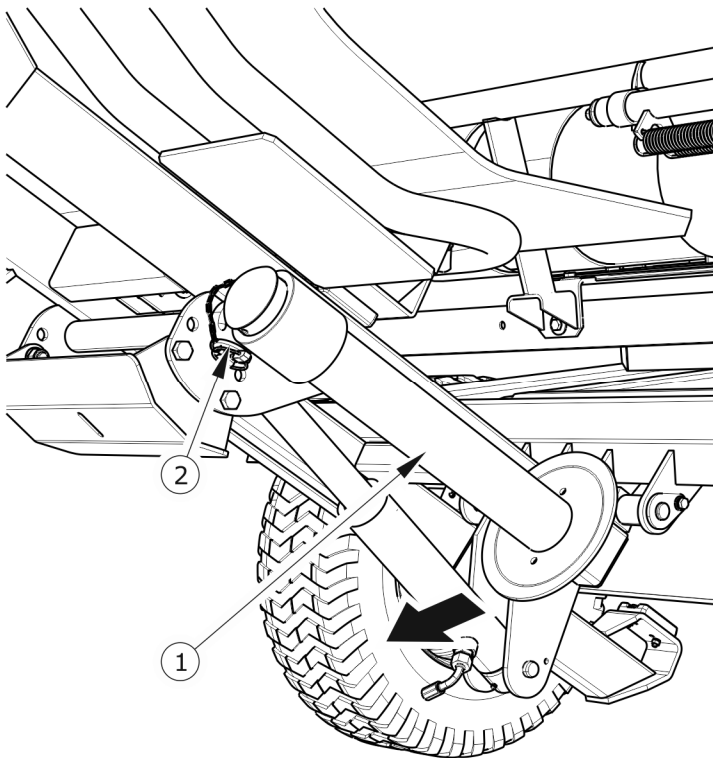

FIGURE 5.13 *Changes in the lateral tipping arm position*

(1) side tipping arm, (2) securing cotter pin

The method of unloading the bale depends on the position of the side tipping arm. With the position shown in figure (5.12), the unloading bale rolls behind the wrapper. If the side tipping arm is turned to the vertical position, the unloading mechanism table will touch the tipping arm slider (1) during its descent, thanks to which it will turn to the left side of the wrapper, thus unloading the bale to the side.

To change this setting, raise the unloading table frame with the hydraulic cylinder. Then, after disassembling the securing cotter pin (2), move the arm (1) to the vertical position. Install cotter pin and lower table frame.

5.10 ADJUSTING OF THE POSITION OF THE REVOLUTION SENSOR

The revolution sensor (1) of the counter is located on the bracket (2) of the right-side member of the frame, figure (5.13). The position adjustment must be carried out when the speed reading on the counter does not correspond to the actual values. One reason for missing

readings may be that the sensor is not positioned correctly in relation to the magnet attached to the turntable frame.



ADVICE

Easier access to the revolution sensor is when the turntable is raised. Before adjusting, support the turntable and stop the tractor engine.

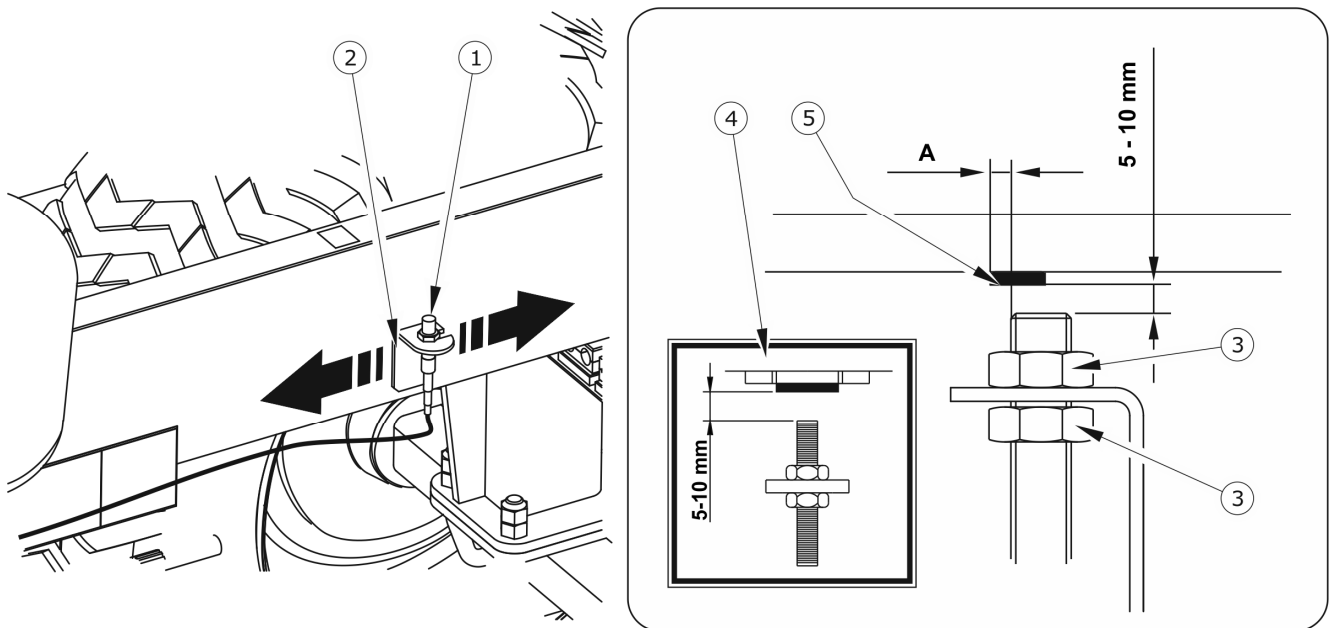

FIGURE 5.14 The principle of adjusting the speed sensor

(1) revolution sensor, (2) bracket, (3) nut, (4) information sticker, (5) permanent magnet, (A) measurement distance

THE SCOPE OF SERVICE ACTIVITIES

- ➔ Connect the wrapper to the tractor, connect the hydraulic lines.
- ➔ Immobilize tractor with parking agricultural brake.
- ➔ Position the turntable so that the magnet attached to the table frame is as close as possible to the sensor. Turn off the tractor engine and secure the cabin against unauthorized access.
- ➔ Measure the vertical distance between the magnet and the sensor.
- ➔ Measure the distance along the cut-out line on the support (dimension A).
- ➔ Loosen the nuts (3), adjust the height of the sensor by adjusting the position of the upper nut.
 - ⇒ The distance should be between 5 and 10 mm as indicated by the decal (4).

- ➔ Move the sensor along the notch to centre the sensor in relation to the magnet.
- ➔ Tighten the lower nut (3).
- ➔ Connect the speed sensor cable to the counter, check that the counter is correct. Readjust sensor position if necessary.

5.11 BELTS TENSION ADJUSTMENT

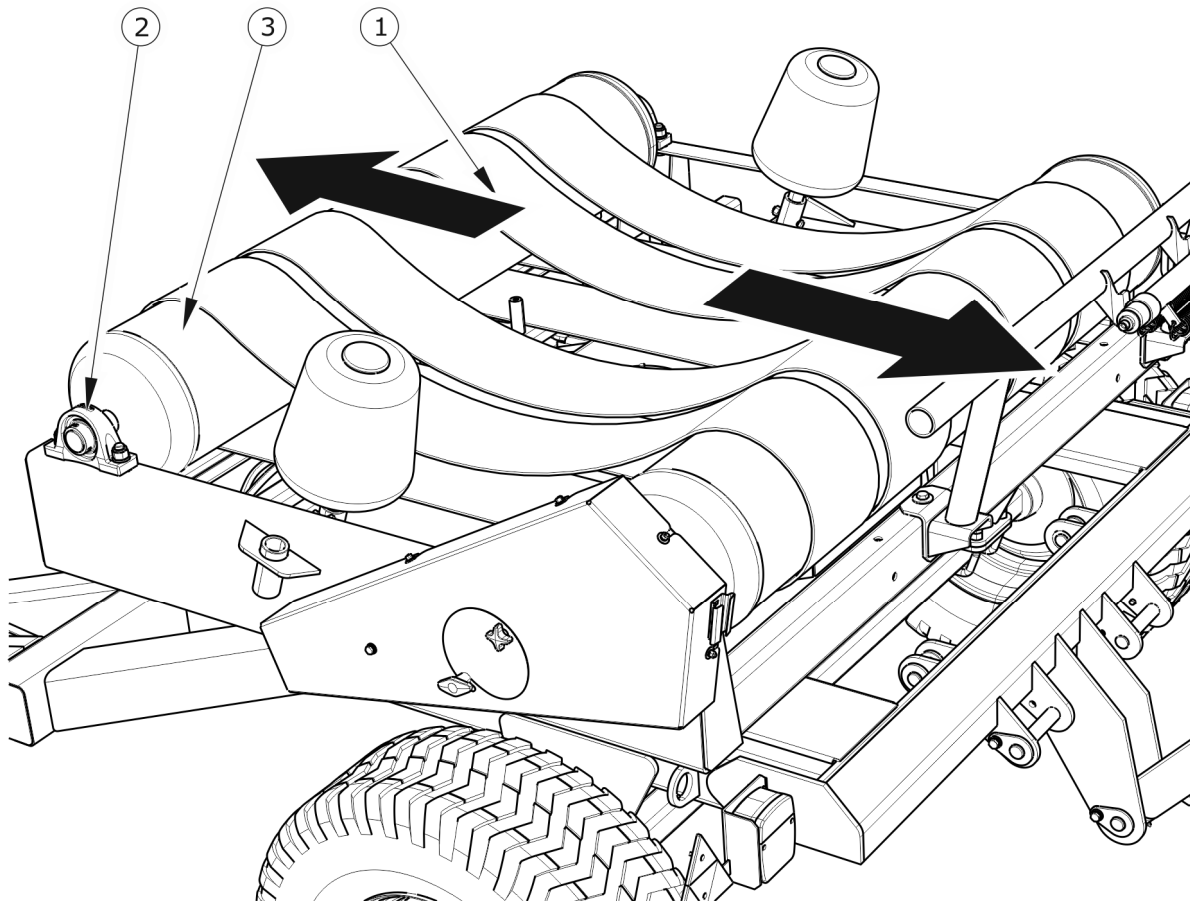

FIGURE 5.15 Belts tension adjustment

(1) belt, (2) bearing unit, (3) idler roll

During the operation of the wrapper, belts (1) – figure (5.14) are stretched. If they begin to rub against the table structure, the tension should be adjusted.

TENSION OF THE BELTS

- ➔ Hitch a wrapper to the tractor, immobilize tractor with parking brake.
- ➔ Turn off the tractor engine and secure the cabin against unauthorized access.
- ➔ Remove the chain case guard.

- ➔ Loosen the nuts of the bearing units (2) of the passive roller (3), (not driven).
- ➔ Move the bearing units out of the table.
- ➔ Tighten the nuts of the bearing units.
- ➔ Check the distance between the passive roller axis and the active roller axis. Check the distance between the idler roll shaft and the turntable frame side member.
- ➔ If the measurements are identical, the rollers are parallel to the table side member and to each other. If not, correct the position of the active roller first and then the passive roller.
- ➔ If the belts are pulled out enough to make adjustments, replace them with new ones.

5.12 WRAPPER LUBRICATION

The wrapper should be lubricated with a hand or foot grease gun, filled with the recommended lubricant. If possible, remove old grease and other contaminants before starting work. After finishing work, wipe off excess grease. Clean the chains before lubrication with kerosene or chain cleaning agents. Lubricate the chains after the cleaning agent has completely dried.

Parts that should be lubricated using machine oil should be wiped with a dry clean cloth and then applied to the lubricated surfaces with a small amount of oil (oiler or brush). Wipe off excess oil.

The replacement of grease in wheel hub bearings should be entrusted to specialized service points equipped with the appropriate tools. According to the axle manufacturer's recommendations, the entire hub must be disassembled, the bearings and individual sealing rings removed. After thorough cleaning and inspection, install lubricated components. If necessary, bearings and seals should be replaced. Lubrication of axle bearings should be carried out at least once every 2 years or after covering 50,000 km. In the event of intensive use, this should be done more often.

Empty containers of grease or oil should be disposed of in accordance with the lubricant manufacturer's instructions.

TABLE 5.3 *Machine lubrication schedule*

ITEM	LUBRICATION POINT	NUMBER OF LUBRICATION POINTS	TYPE OF GREASE	FREQUENCY
1	Hub bearings	2	A	24M
2	The strut bolt	1	A	6M
3	Drawbar hitch eye	1	B	80R
4	Rotary link	1	B	80R
5	Load arm pins	2	A	20R
6	Gripper arm pin	1	A	20R
7	The load arm cylinder lateral bearings	2	A	40R
8	Gripper arm cylinder lateral bearings	2	A	40R
9	The lateral bearings of the tipping cylinder	2	A	40R
10	Discharge arm pins	2	A	20R
11	Discharge arm cylinder radial bearings	2	A	40R
12	Table pivot pins	2	A	20R
13	Cutting knife	2	C	P
14	The rear pressure plate guides	1	A	P
15	Foil feeder gear	1	A	12R
16	Pressure plate guide	2	A	40R
17	turntable bevel gear	2	A	80R
18	Drive chains	2	B	40R
19	Drawbar bolt	1	B	20R
20	Roller drive chain	1	B	80R
21	Cable-operated distributor (optional)	4	A	12M

(1) – if it is included in the assembly of the machine,

Lubrication intervals - M month, R - man hour, P - after work

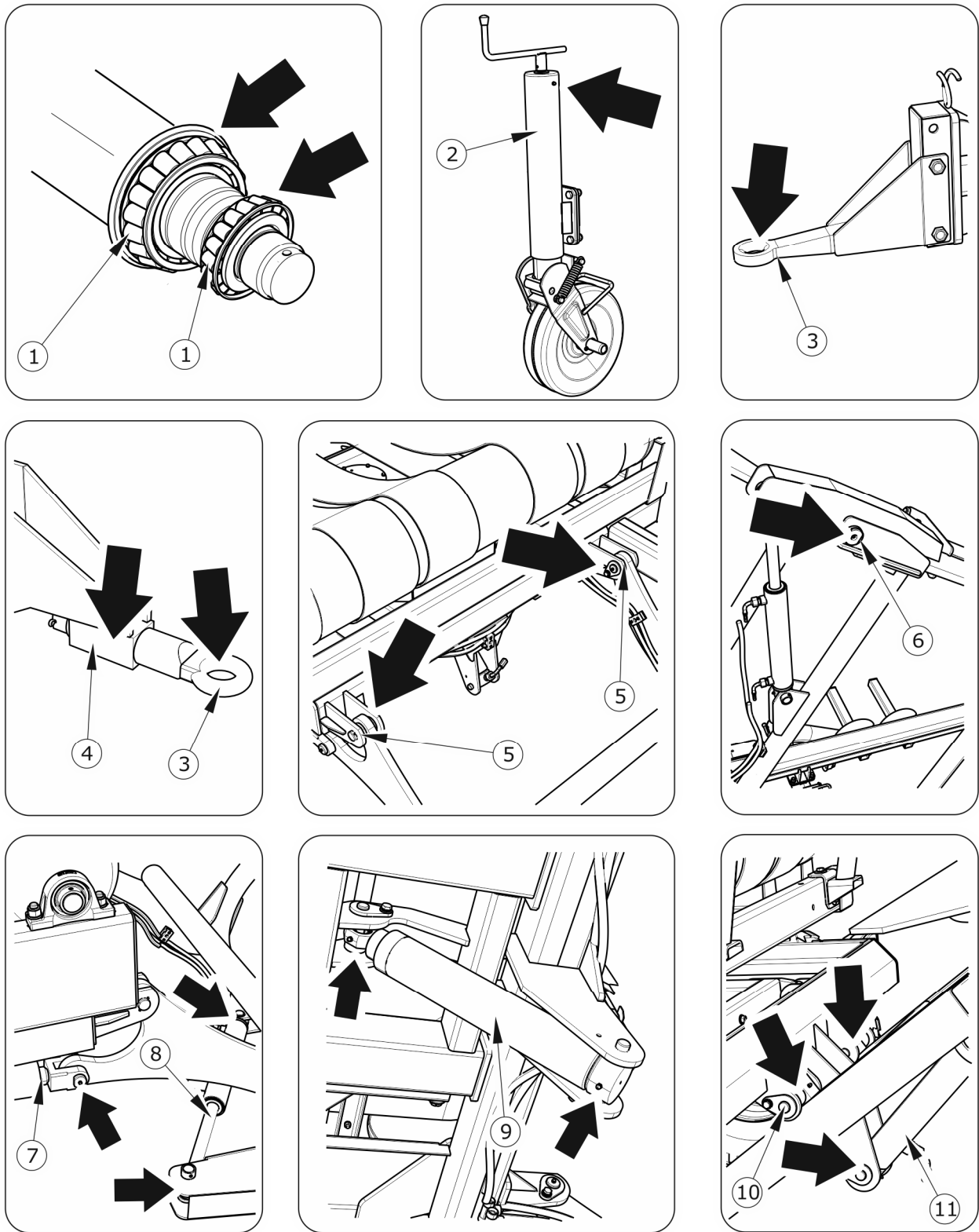

FIGURE 5.16 *Wrapper lubrication points, part 1*

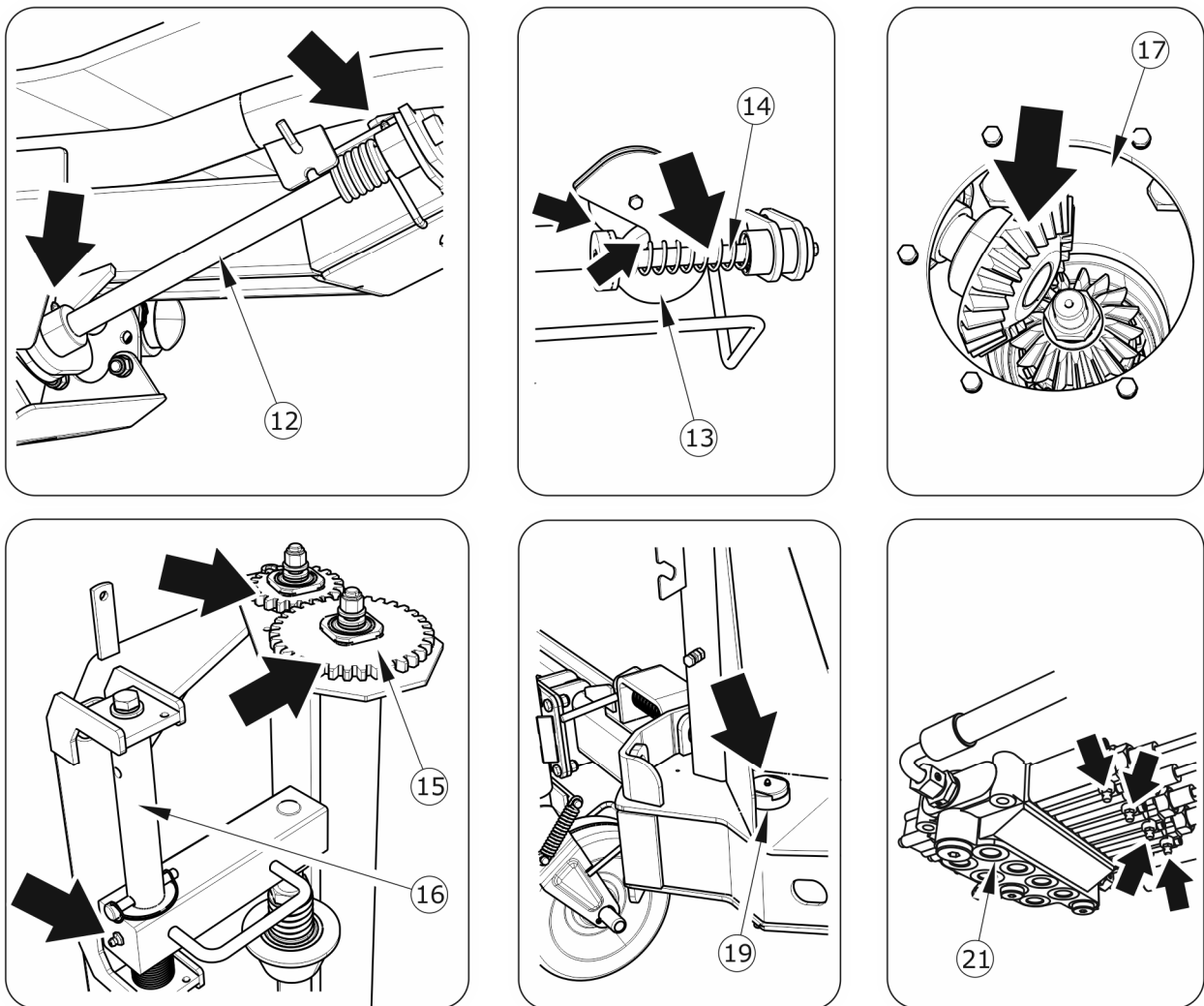

FIGURE 5.17 *Wrapper lubrication points, part 2*

TABLE 5.4 *Recommended lubricants*

Designation from table (5.4)	DESCRIPTION
A	general purpose machine grease (lithium, calcium),
B	solid grease for heavily loaded components with the addition of MoS2 or graphite
C	plain machine oil, silicone spray grease



OVERVIEW

When using the wrapper, the user is obliged to follow the lubrication instructions in accordance with the lubrication schedule.

5.13 CONSUMABLES

5.13.1 HYDRAULIC OIL

It is absolutely necessary to observe that the oil in the wrapper's hydraulic system and the tractor's hydraulic system must be of the same type. If different types of oil are used, make sure that both hydraulic means can be mixed together. The use of different types of oil may cause damage to the wrapper or agricultural tractor. The new machine is filled with L HL32 Lotos hydraulic oil.

TABLE 5.5 Characteristics of hydraulic oil L-HL 32 Lotos

Item	Name	Unit	Value
1	Viscosity classification according to ISO 3448VG	-	32
2	Kinematic viscosity at 400C	mm ² /s	28.8 – 35.2
3	Qualitative classification according to ISO 6743/99		HL
4	Quality classification according to DIN 51502		HL
5	Flash-point	C	230

If you need to change the hydraulic oil for another oil, read the oil manufacturer's instructions carefully. If he recommends flushing the system with an appropriate preparation, follow these recommendations. It must be ensured that the chemicals used for this purpose do not act aggressively on the materials of the hydraulic system. During normal operation of the wrapper, it is not necessary to change the hydraulic oil, however, if necessary, this operation should be entrusted to specialist service centres.

The oil used, due to its composition, is not classified as a dangerous substance, however long-term effects on the skin or eyes may cause irritation. In the event of contact of oil with skin, wash the place of contact with water and soap. Do not use organic solvents (gasoline, kerosene). Soiled clothing should be removed to prevent oil from getting on your skin. If the oil gets into your eyes, flush them with plenty of water and in case of irritation contact your doctor. Hydraulic oil under normal conditions is not harmful to the respiratory tract. The hazard only occurs when the oil is strongly atomized (oil mist), or in the event of a fire during which toxic compounds may be released. Oil should be quenched with carbon dioxide, foam or extinguishing steam. Do not use water to extinguish a fire.

5.13.2 LUBRICANTS

For heavily loaded parts, it is recommended to use lithium grease with the addition of molybdenum disulphide (MOS₂) or graphite. For less loaded components, it is recommended to use general-purpose machine greases that contain anti-corrosive additives and are highly resistant to water washout. Aerosol preparations (silicone greases, anti-corrosive lubricants) should have similar properties.

Before using lubricants, read the information leaflet for the selected product. Particularly important are safety rules and how to handle a given lubricant and how to dispose of waste (used containers, contaminated rags, etc.). The information leaflet (product card) should be kept together with the grease.

5.14 CLEANING OF THE WRAPPER

The wrapper should be cleaned depending on demand and before a longer standstill (e.g., before winter). The use of a pressure washer obliges the user to become familiar with the principle of operation and recommendations for the safe operation of this device.

Guidelines for the wrapper cleaning

- Thoroughly clean the machine of any grass or film before cleaning the wrapper.
- Use only clean running water or water with a cleaning detergent additive with a neutral pH.
- The use of pressure washers increases the effectiveness of washing, but be careful when working. During washing, the nozzle of the cleaning aggregate must not be closer than 50 cm from the surface being cleaned.
- The water temperature should not exceed 55 ° C.
- Do not direct the water stream directly at the elements of the wrapper's installation and equipment, i.e., hydraulic cylinders, hydraulic plugs, lights, electrical connectors, information and warning stickers, rating plate, cable connectors, lubrication points of the wrapper, etc. High pressure of the water stream may cause mechanical damage to these elements or water ingress.
- For cleaning and maintenance of plastic surfaces, it is recommended to use clean water or specialized preparations intended for this purpose.

- Do not use organic solvents, preparations of unknown origin or other substances that may damage the lacquered, rubber or plastic surface. It is recommended to make a test on an invisible surface in case of doubt.
- Surfaces oily or greasy by grease should be cleaned with petrol or degreasing agents, and then washed with clean water and detergent. Follow the cleaning agent manufacturer's instructions.

**DANGER**

Refer to the instructions for using cleaning detergents and preservatives.

When washing with detergents, wear suitable protective clothing and eye protection.

- Detergents intended for washing should be stored in their original containers, or alternatively, but marked exactly. The preparations cannot be stored in containers intended for storing food and beverages.
- Keep the hoses and gaskets clean. The materials from which these elements are made may be susceptible to organic substances and some detergents. As a result of long-term effects of various substances, the aging process is accelerated and the risk of damage increases. Elements made of rubber are recommended to be maintained with the help of specialized preparations after thorough washing.
- Observe environmental protection principles, wash wrapper in designated places.
- Washing and drying the wrapper must take place at an ambient temperature above 0 °C.
- After washing and drying the wrapper, lubricate all control points, regardless of the period of the last treatment. Wipe off excess grease or oil with a dry cloth.
- Use extraction gasoline to clean the film feed rollers from the adhesive residue.

5.15 STORAGE

- It is recommended that the wrapper be stored indoors or under a roof.
- If the machine will not be used for a long period of time, it must be protected against the effects of weather conditions, especially those that cause corrosion of steel and accelerate the aging of tires. The wrapper should be thoroughly washed and dried.

- Corroded areas should be cleaned of rust, degreased and protected with a primer paint, and then painted with a topcoat according to the colour scheme.
- In the event of a longer stop, it is necessary to lubricate all components regardless of the period of the last treatment.
- When the wrapper is stationary for a long time, it is recommended to remove the drive chains, wash them in kerosene and protect them with a preservative or general-purpose grease.
- Rims and tires should be carefully washed and dried. During longer storage of the unused wrapper, it is recommended to move the machine once every 2-3 weeks so that the place of contact of the tire with the ground is in a different position. The tires will not deform and will maintain proper geometry. You should also check your tire pressure from time to time, and if necessary, inflate the wheels to the correct value.
- The electronic counter must be stored at home. If the machine has been idle for a longer period, remove the battery from the counter.

5.16 TIGHTENING TORQUE FOR NUT AND BOLT CONNECTIONS

TABLE 5.6 *Tightening torques for screw connections*

METRIC THREAD	5.8(1)	8.8(1)	10.9(1)
	Md [Nm]		
M10	37	49	72
M12	64	85	125
M14	100	135	200
M16	160	210	310
M20	300	425	610
M24	530	730	1,050
M27	820	1,150	1,650
M30	1,050	1,450	2,100

(1) - strength class according to DIN ISO 898

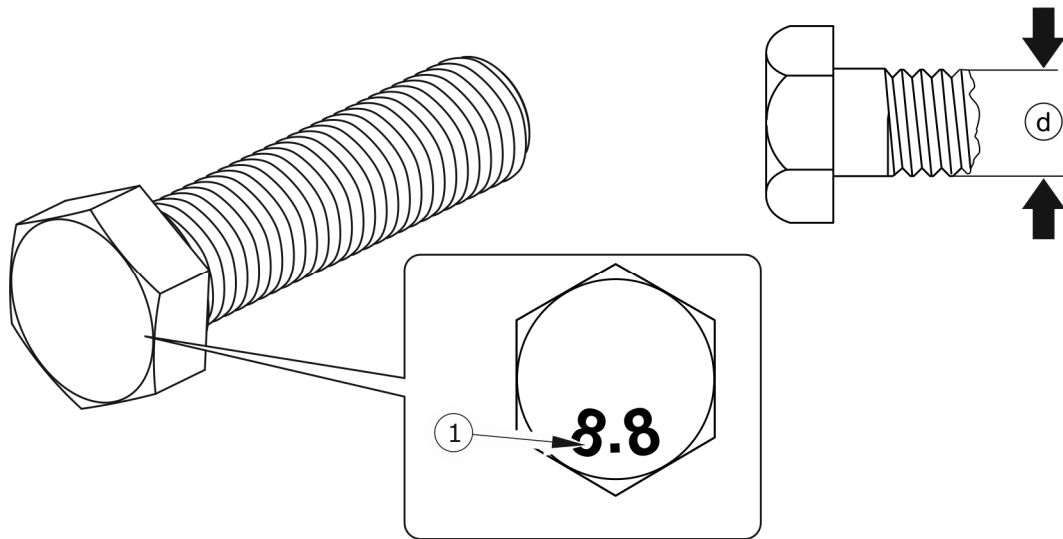

FIGURE 5.18 *Metric thread screw*

(1) strength class, (d) thread diameter

During maintenance and repair work, apply appropriate tightening torques to screw connections, unless other tightening parameters are given. Recommended tightening torques for the most commonly used bolted connections are shown in the Table (5.6). The given values apply to non-lubricated steel bolts



ADVICE

The hydraulic hoses should be tightened with a torque of 50 - 70 Nm.

5.17 ADJUSTING THE POSITION OF THE DRAWBAR

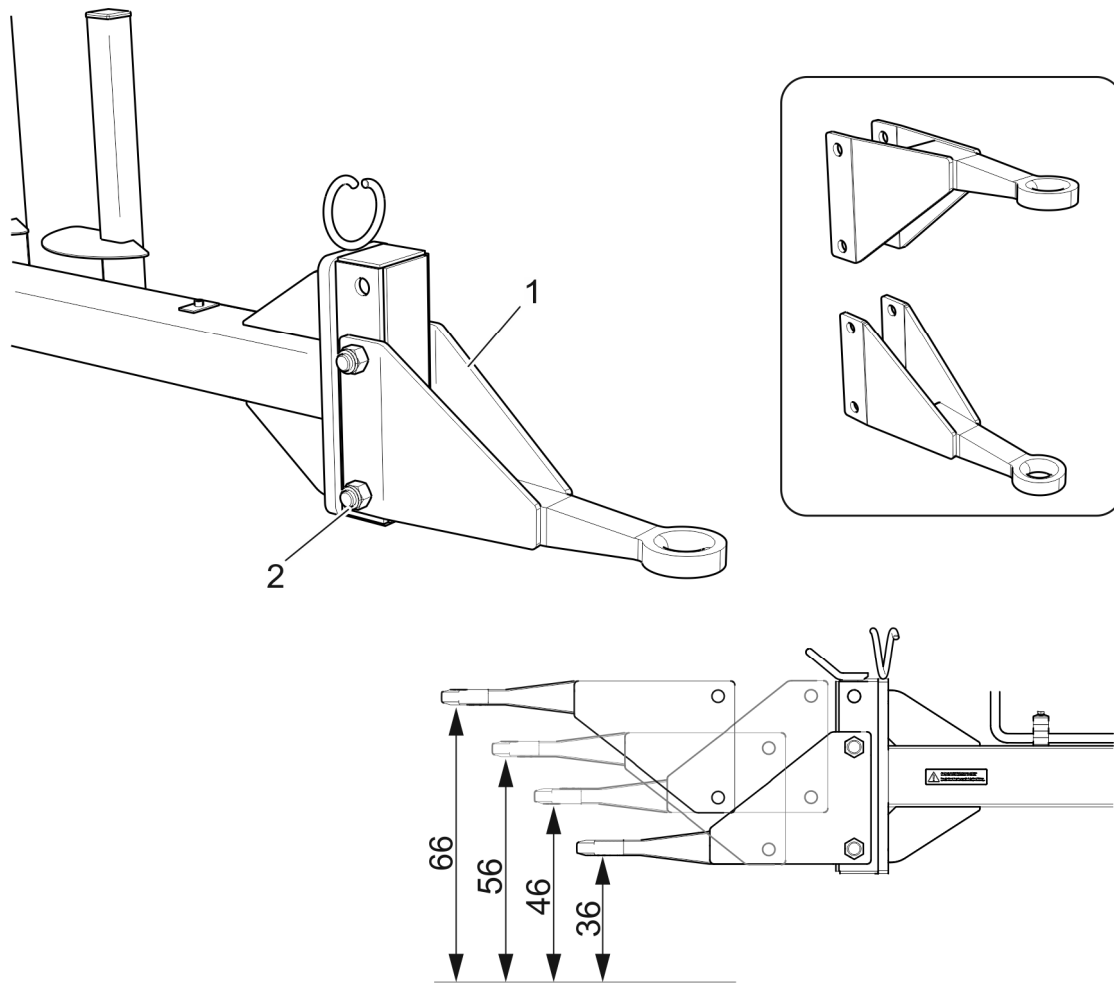

FIGURE 5.19 *Adjusting the position of the drawbar*

(1) drawbar with fixed link, (2) bolted connection

THE SCOPE OF ACTIVITIES

- ➔ Place chocks or parts without sharp edges under the wrapper wheels.
- ➔ Unscrew the drawbar from the frame.
- ➔ Move the drawbar to the new position and tighten it to the specified torque.
- ➔ The frame design allows for 4 combinations of drawbar positioning, compare figure (5.18).
- ➔ Check the tightness of the drawbar after the first pass under load.

5.18 FILM TENSION ADJUSTMENT

The degree of tension of the film has a decisive influence on the quality of the silage. Optimal conditions for the formation of feed are achieved thanks to the close adhesion of the film layers. Too much tension will cause the next layer to be covered (the film must overlap at least half of the width during wrapping).

CHECKING THE FOIL TENSION LEVEL – METHOD 1

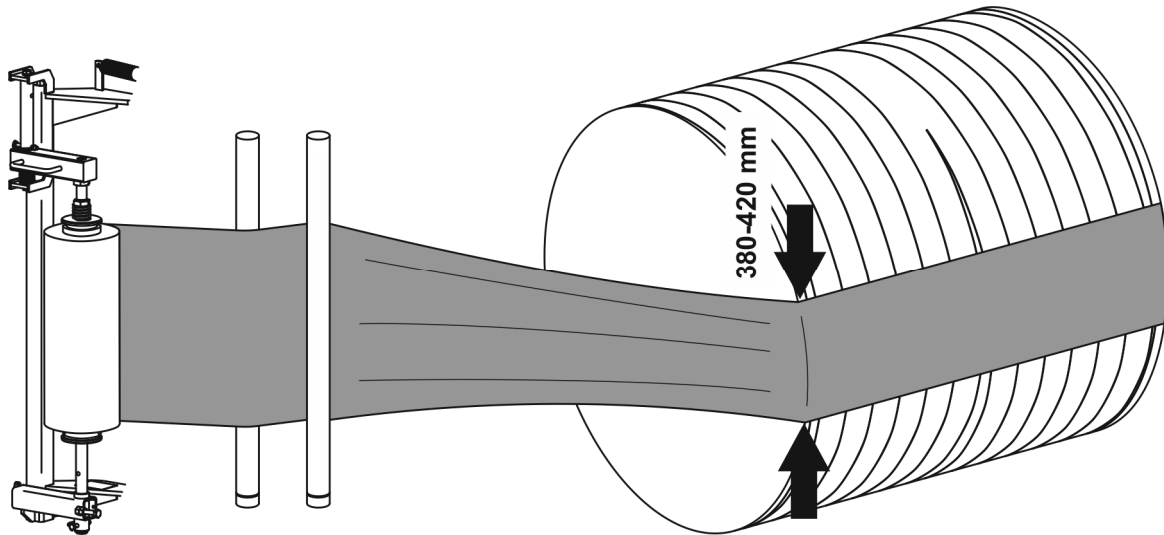

FIGURE 5.20 Method 1 for checking the foil tension

The determination of the foil tension in Method 1 is based on the measurement of the film width at the edge of the wrapped bale, refer to figure (5.19). The measured film value shown in the diagram is for 500 mm rollers.

TABLE 5.7 Film dimensions at initial tension 55 – 70%

Roll size [mm]	Film width [mm]	
	55%	70%
500	380	420
750	580	620

The width of the film measured at the edge of the bale should be as shown in the table (5.7).

ADVICE

The given film dimensions are indicative and were developed on the basis of a film with a stretch of 70%. Read the instruction manual of the film manufacturer and the recommendations for setting the pretension before working with the wrapper.

CHECKING THE FOIL TENSION LEVEL – METHOD 2

FIGURE 5.21 Method 2 for checking the foil tension

Determining of the degree of film tension in method 2 consists in drawing 2 parallel lines on the roll placed in the feeder. The distance between the lines must be 100 mm. As a result of the stretch of the film layer, the distance between the drawn lines will increase. The correct line distance with the foil voltage of 55 – 70% should be between 155 and 170 mm.

THE SCOPE OF SERVICE ACTIVITIES

- ➔ Determine the current foil tension using one of the methods selected.
- ➔ Turn off the tractor engine, secure the cabin against unauthorized access. Immobilize tractor with parking brake.
- ➔ Loosen the lock nuts (1).
- ➔ Adjust the new position of the top pin.
 - ⇒ If the film was too tight, the pin must be screwed in (the top support roller will move upwards).
 - ⇒ If the film was too tight, the pin must be removed (the top support roller will move downwards).

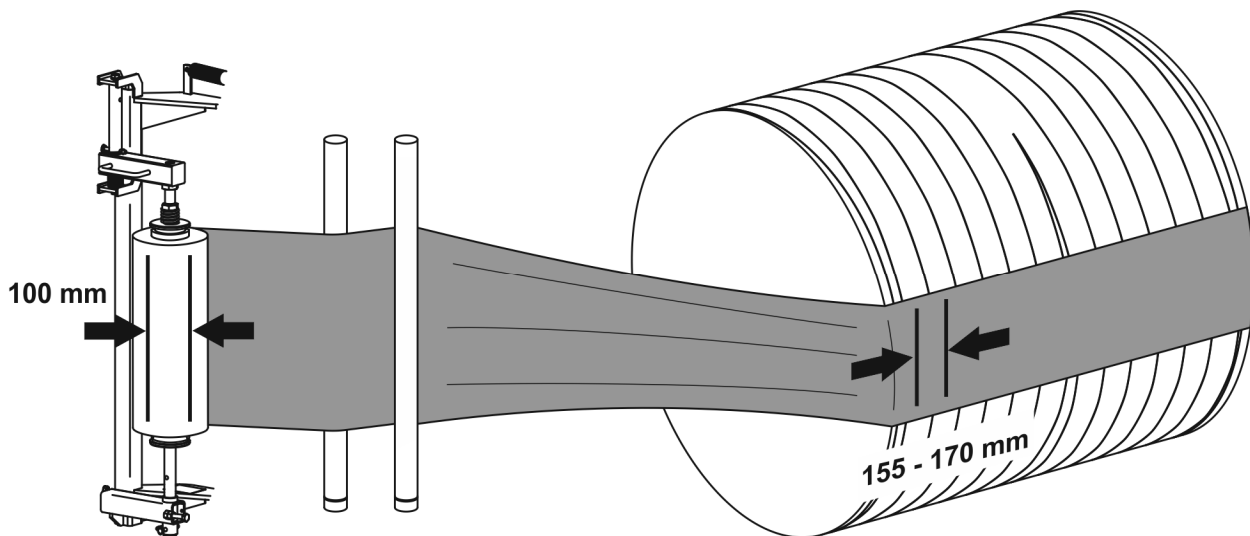
- ➔ Tightening the locknut.
- ➔ Check that the foil is correctly tensioned, repeat if necessary.

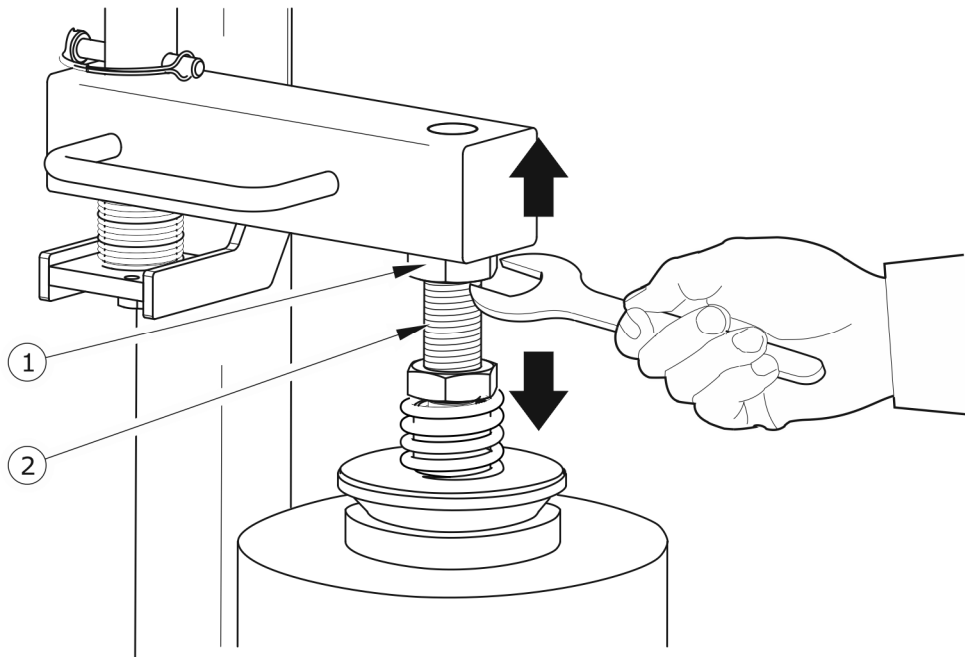

FIGURE 5.22 *Belts tension adjustment*

(1) locknut, (2) upper pin

5.19 REPLACEMENT AND ADJUSTMENT OF CUTTING KNIVES

During the operation of the wrapper, the cutting knives wear and tear, which is a normal symptom, as a result of which the film may not be properly cut off. In this case, the knives can be rotated to a position where the edge is still sharp. If the knives are completely damaged, replace them with new ones.



DANGER

Special care should be taken during operation due to the risk of injury.

THE SCOPE OF SERVICE ACTIVITIES

- ➔ Connect the wrapper to the tractor, connect the hydraulic lines.
- ➔ Position the turntable to allow easy access to the cutter bar.
- ➔ Unscrew the nuts, remove the bolts securing the knives.
- ➔ Remove the knife guard (2) and the knives (1).

- ➔ Install a new set of knives.
 - ⇒ The knives must be flat against each other - see figure (5.22).
 - ⇒ When assembling, remember to put on the spacers correctly.
- ➔ Tighten the nuts to the specified torque.

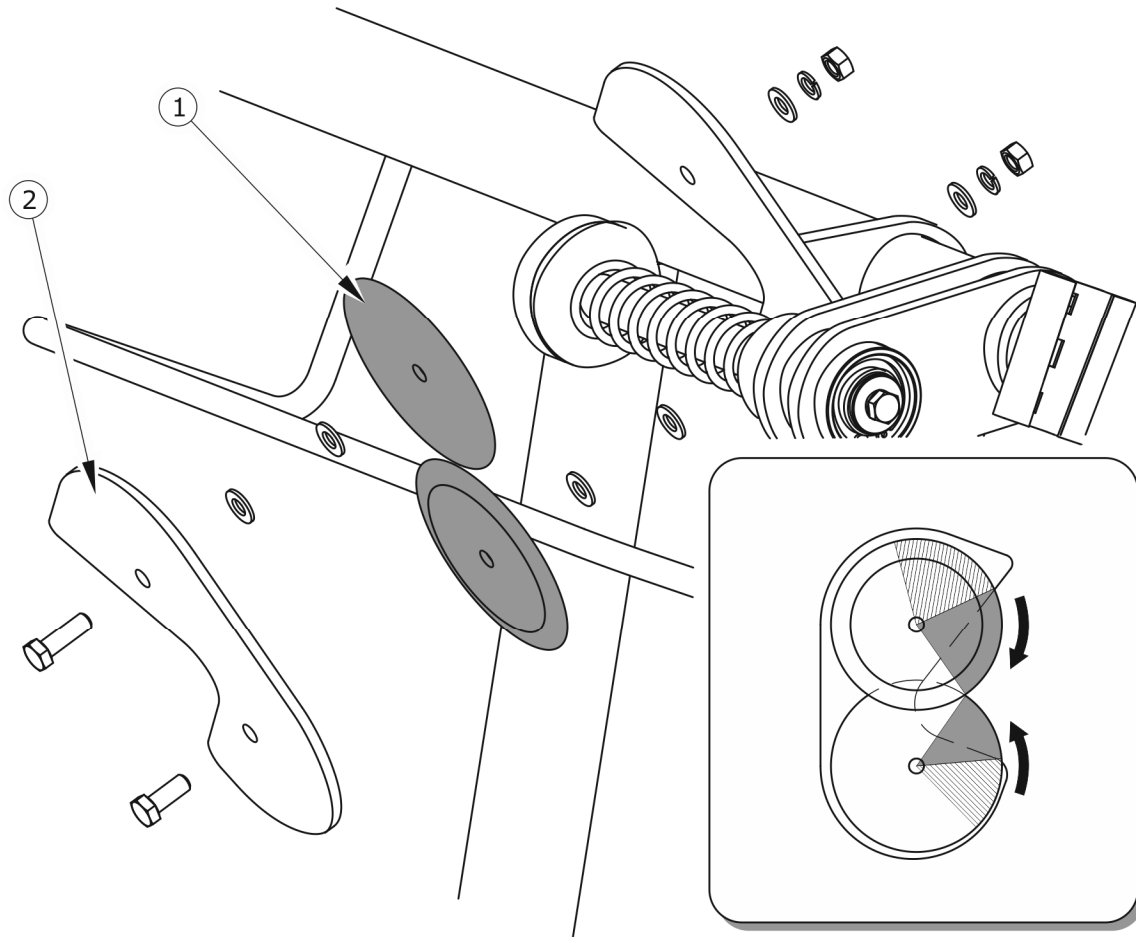



FIGURE 5.23 Replacement of the cutting knives

(1) cutting knife, (2) knife guard



ADVICE

If the knives are not replaced, but only turned to the new position, the guard does not need to be removed. In this case, it is sufficient to loosen the mounting nuts.

5.20 STORAGE, MAINTENANCE AND REPAIR OF THE WRAP COUNTER

5.20.1 STORAGE AND CLEANING OF THE COUNTER

When not in use, the counter should be stored in room conditions, protected from moisture, chemicals, direct precipitation, frost and strong sunlight. After disconnecting the sensor cable, wind up and protect the sensor plug contacts from dirt and moisture, which can cause corrosion and loss of electrical contact, resulting in incorrect operation of the meter. The counter does not require periodic maintenance except for replacing the old battery with a new one (only for counter L01). During extended periods of non-use, especially after the end of the field season, remove the battery from the housing to avoid battery leakage, which can permanently damage the counter electronics. If the counter housing is dirty, it can be cleaned with a slightly damp cloth with detergent. Do not use any other organic solvents (acetone, petrol, nitro solvent, etc.), as they can dissolve the counter housing. If the counter is damaged, have it serviced by the manufacturer. If you attempt to repair the counter yourself, the warranty will be void.

5.20.2 BATTERY REPLACEMENT(COUNTER L01)

Always replace the battery before the start of the new field season or if it is discharged. Battery discharge is manifested by unusual operation of the meter: accidental blanking of the display, low contrast of displayed digits, etc. After the end of the field work season, the meter should be stored in a dry and warm room with the battery removed.

To replace the battery pack, remove the battery pack cover. Remove the battery from the battery compartment and disconnect the power cable. Attach the new battery, noting the polarity of the power supply (the battery latch fits in only one position), insert the battery into the battery container and close the cover. Check the operation of the counter by switching it on. Use 9V, standard 6F22 or alkaline type 6LR61 (recommended) for power supply. Alkaline batteries have a longer life without having to replace them.

5.21 TROUBLESHOOTING

TABLE 5.8 *Faults and how to remove them*

FAULT	CAUSE	REMOVAL METHOD
Noise in the hub of the axle	Excessive bearing looseness	Check the clearance and adjust if necessary
	Damaged bearings	Replace bearings
	Damaged hub components	Replace
Incorrect hydraulic system operation	Incorrect hydraulic oil viscosity	Check the oil quality, make sure that the oils in both machines are of the same grade. If necessary, change the oil in the tractor and/or wrapper
	Insufficient tractor hydraulic pump performance, tractor hydraulic pump defective.	Check the hydraulic pump on the tractor.
	Damaged or dirty actuator	Check the cylinder piston rod (bending, corrosion), check the cylinder for leaks (piston rod seal), repair or replace the cylinder if necessary.
	Damaged hydraulic lines	Check and make sure that the hydraulic hoses are tight, not kinked and properly tightened. Replace or tighten as necessary.
Incorrect rev counter readings	Faulty sensor cable or sensor	Replace the cable or the revolution sensor.
	Sensor position incorrectly adjusted	Check and adjust.
	No magnet attached to the turntable	Attach a new magnet to the turntable seat.
Low contrast of displayed digits, display malfunction	Battery empty (L01)	Replace the battery.
	Faulty display	Repair or replace the counter.

	Incorrect supply voltage (L02)	Check the voltage at the cigarette lighter socket (12V). Repair the supply circuit.
Err1 or Err2 error message displays	Incorrect supply voltage (L02)	Check the voltage at the cigarette lighter socket (12V). Repair the supply circuit.
Counter L02 does not start	Blown fuse	Check fuse (8A) located in the power plug.
Unloading table falling too fast	Incorrect hydraulic oil level	Check viscosity, change tractor oil.
	Invalid flow regulator setting	Check and adjust.
	Faulty flow regulator	Replace.
Noise from the chain gears	Loose chain	Adjust chain tension.
	Drive chain tension too high.	Replace the chain with the sprockets.
	Damaged or contaminated bearings	Check the bearings, replace if there is excessive wear.
Foil is too tight	Upper support roller height not adjusted correctly	Adjust the foil hold down.
	The film slides on the film feeder rollers	Clean the knurled surfaces with kerosene and a copper brush.
Foil stripping	Foil roll pressure too high	Reduce the film pressure by adjusting the height of the upper support roller.
	Foil damaged	Check the film and replace if necessary.
	Feeder idlers blocked or bent	Replace the rollers.
	Feeder gearbox defective	Repair the transmission.
	Irregular bale shape	Reduce rotational speed when wrapping. Ensure that the bale is formed correctly.
	Table rotation speed too high.	Reduce rotational speed when wrapping.

Unsymmetrical bale wrapping	Incorrect feeder height	Adjust the height of the film feeder to match the bale size.
	Incorrect selection of the roller drive ratio in relation to the film	Adjust the wrapper to the width of the film
Bale falls off table	Irregular bale shape	Reduce rotational speed when wrapping. Ensure that the bale is formed correctly.
	Table rotation speed too high.	Reduce rotational speed when wrapping.
The film is not cut	Damaged or dull knives	Replace or change knife setting.

NOTES

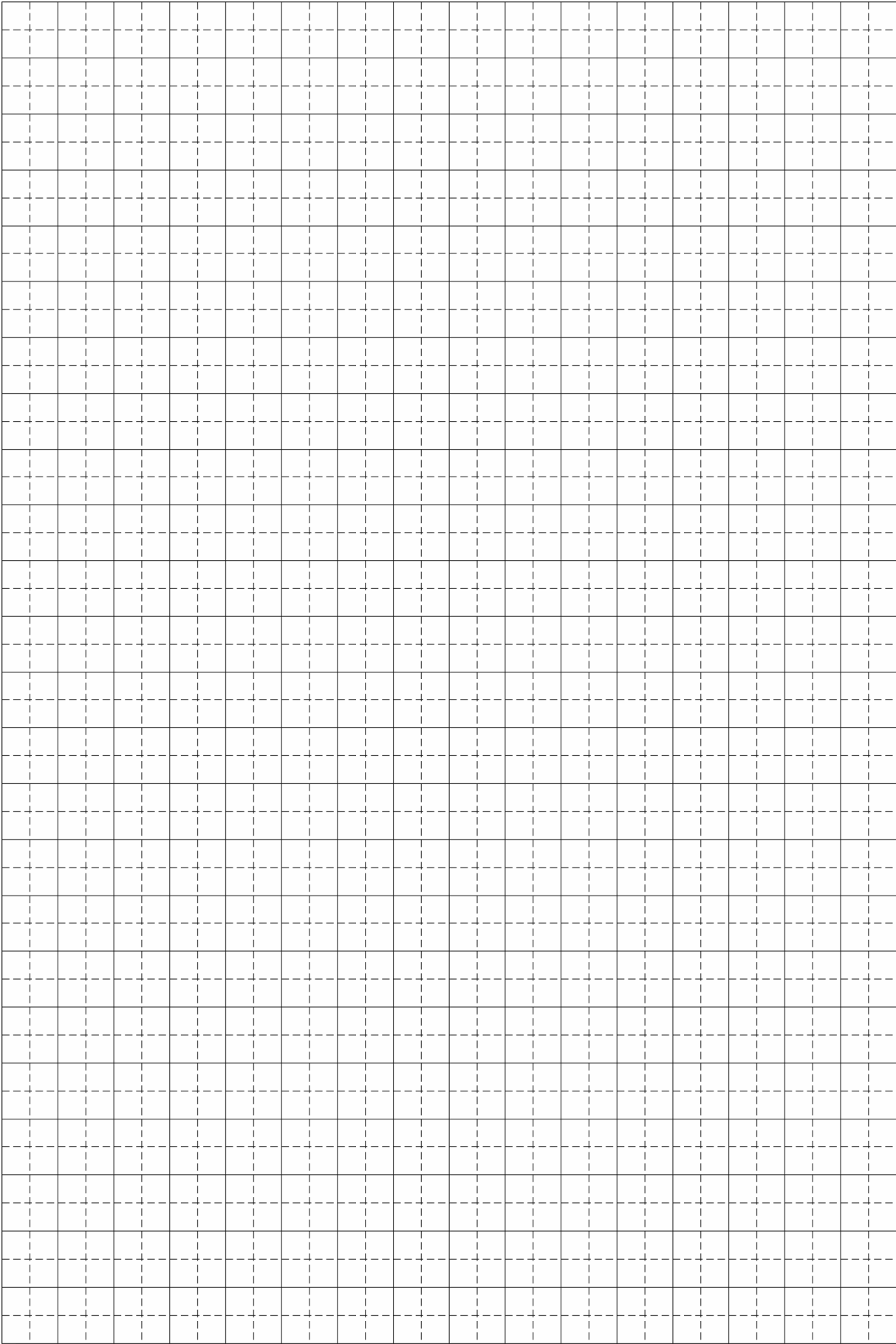

APPENDIX A

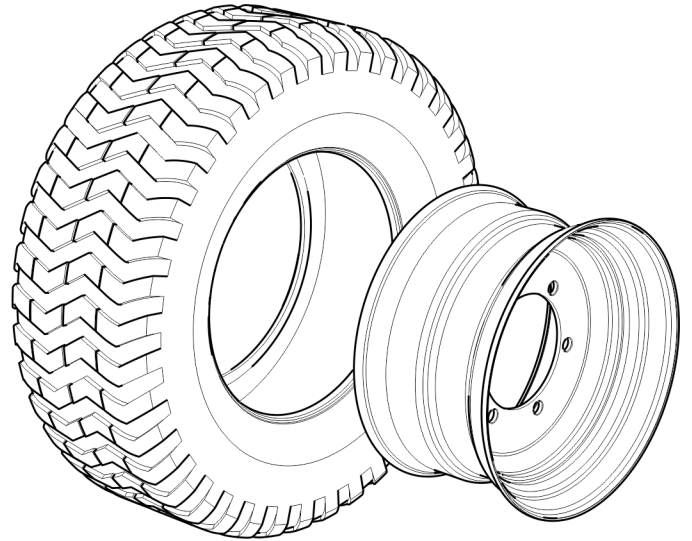

TIRE ASSEMBLY

ITEM	TIRE	RIM
1	350/50-16 133A8	11,00x16 ET=0
2	340/55-16 133A8	11,00x16 ET=0
3	340/55-16 140A8	11,00x16 ET=0

ATTACHMENT B

B.1 CONNECTING THE CONTROL SYSTEM

The control system consists of a module that is mounted on the bale wrapper, cables, a set of sensors and a control panel.

- Connect the bale wrapper according to the recommendations contained in the Operator's Manual.
- Connect the control panel to the module mounted on the bale wrapper using a communication cable.
- Connect the module's feeder cable to the tractor.
- Make sure that the electrical cables will not be damaged by moving parts of the bale wrapper and the tractor during operation. If necessary, secure the cables in a proper manner.

B.2 CONTROL PANEL

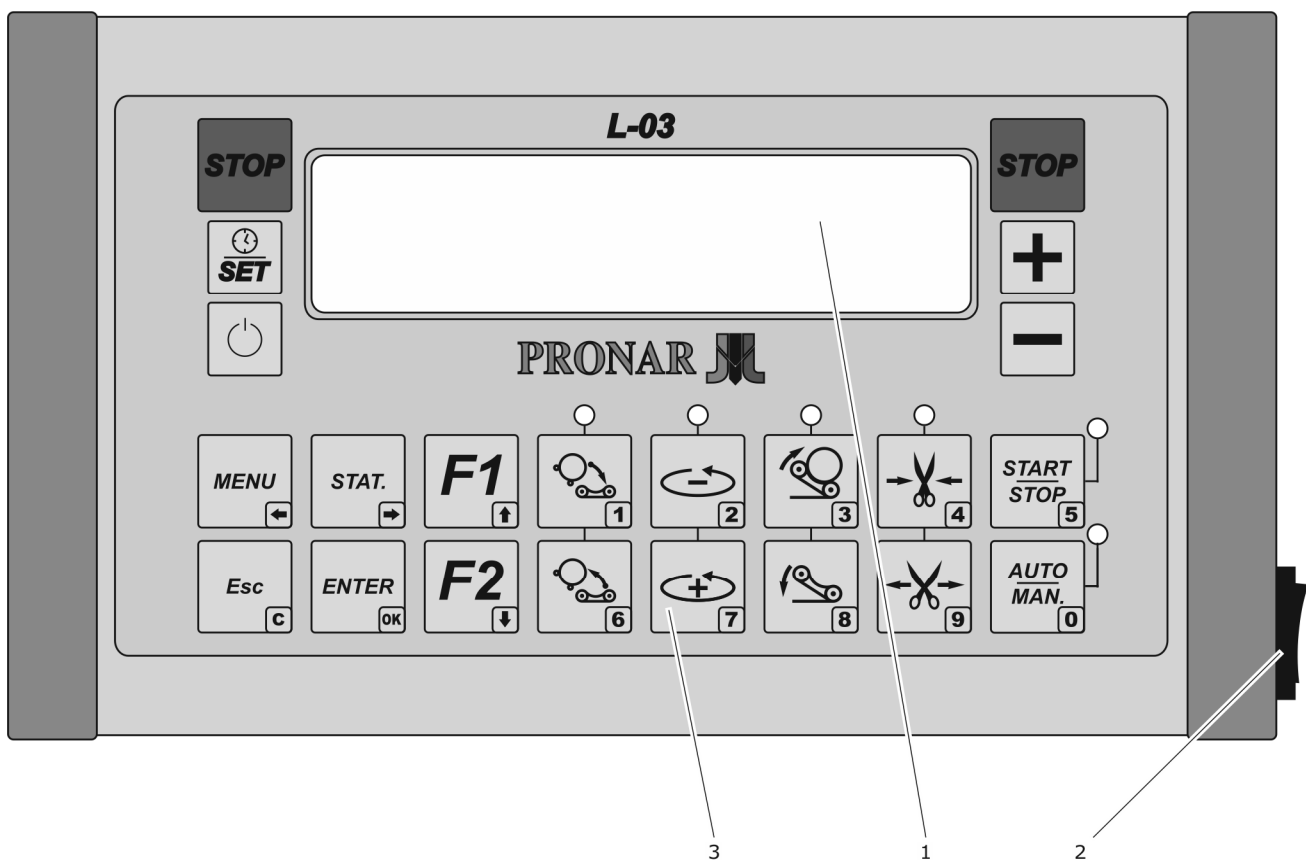























FIG. 1.1 View of the control panel

(1) display (2) switch (3) control keys

TAB. B.1 *Description of the functions of the control panel keys*

ITEM	KEY	DESCRIPTION
1		Emergency stopping of the bale wrapper operation.
2		Viewing a currently set date and time
3		Switching on and off the control panel.
4		Increasing the value
5		Decreasing the value
6		Entering the menu. Moving the cursor to the left (date and time menu)
7		Cancelling the selection, exiting to the main menu level.
8		Viewing the statistical data. Moving the cursor to the right (date and time menu)
9		Confirming the selection.
10		Controlling the items upwards in Menu mode. Unlocking after an emergency stop. Resetting the counter.

ITEM	KEY	DESCRIPTION
11		<p>Controlling the items downwards in Menu mode.</p> <p>Unlocking after an emergency stop.</p> <p>Entering the bale wrapper's operation mode menu.</p>
12		Rising of the loading arm
13		Lowering of the loading arm
14		<p>Short pressing of the key: setting the turntable in loading or unloading position.</p> <p>Holding the key down: bale wrapping until the key is released.</p>
15		Short pressing of the key: bale wrapping according to a programmed number of wrappings.
16		Tipping the turntable – bale unloading.
17		Lowering the turntable
18		Holding the film
19		Releasing the film
20		Starting the bale wrapper's systems
21		Switching between manual mode and semi-automatic mode

B.3 OPERATION OF THE CONTROL PANEL



TIP

Markings of the keys used in the text refer to table DESCRIPTION OF THE FUNCTIONS OF THE CONTROL PANEL KEYS.

B.3.1 STARTING THE CONTROL PANEL

- Switch the control panel on using the switch located on the right side of the control panel.

- If the diode located next to the switch starts blinking, press key (3). 
- When key (3) is pressed, the diode should stop blinking and the starting sequence of the control system should appear on the display.



Machine identification



Software version. The software version defines the currently installed program and may vary depending on later updates.



Establishing communication between the control panel and the bale wrapper.



Confirmation of readiness for operation.

CONNECTION ERROR
SERVICE !!!

Communication error.

After successful completion of the starting sequence, one of the following messages should appear:

BALES L-01: 12
WRAPS: 24>0

TRANSPORT
POSITION

The message appearing after starting the control panel depends on the working mode in which the controller was switched off. The working mode parameter is stored when the control panel is being switched off

If the message "Transport position" is displayed, press button **F2** and then use button **+** or **-** to select AUTO semi-automatic operation mode or AUTO automatic operation mode.

ATTENTION



If LED does not start blinking after switching on the control panel, check the module's feeder cable and the control panel's communication cable. Contact the seller if the connections are correct and both cables are not damaged.

ATTENTION



If COMMUNICATION ERROR message appears, check the communication cable connecting the control panel with the module. Contact the seller if the connection is correct and the cable is not damaged.

B.3.2 SWITCHING THE CONTROL PANEL OFF

- Set the bale wrapper in transport position or in working position (the loading arm is lowered).
- If the bale wrapper is to be transported, switch the control panel to *TRANSPORT POSITION MODE*.

- Press key (3). 
- Switch the control panel off using the switch on the right side of the control panel housing.

ATTENTION



After completed operation, always switch the control panel off using key (3) first and then using the switch located on the right side of the control panel (set the switch to "0" position). If the control panel is switched off in reverse order, working time data will be partially lost each time (maximally 2 minutes).

In standby mode (the green LED next to "Start/Stop" switch is blinking), the control panel absorbs power from the battery and may completely discharge it.

The following message appears before the control panel is switched off:



B.3.3 EMERGENCY STOPPING OF THE BALE WRAPPER

The control panel is equipped with two emergency stop keys **STOP** – (1). If one of these keys is pressed, the bale wrapper is immediately stopped. 3 red LEDs located next to keys (14), (16) and (18) start blinking, audio signal is activated and the following message appears on the display:



EMERGENCY STOP
WORK => F1+F2

In order to restart the bale wrapper, press simultaneously **F1** key – (10) and **F2** - key (11).



ATTENTION

Emergency stopping of the bale wrapper may be performed only if health and life of people is at risk. Unnecessary use of this stopping mode contributes to overloading the bale wrapper's drive system.

B.3.4 OPERATION IN MANUAL MODE



Press F2 key.

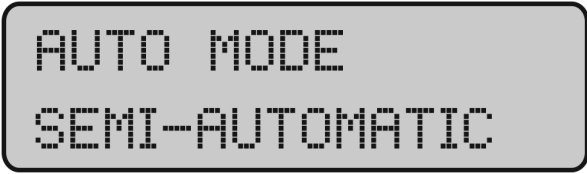

Using + key or – key, choose the following option:

AUTO WORKING MODE

SEMI-AUTOMATIC

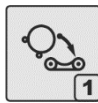

Load a bale onto the turntable – key (12). Keep the key held down while raising the loading arm.



Lower the loading arm – key (13). Keep the key held down while lowering the loading arm.

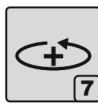

Press key (15). If the key is pressed for a short time, a previously programmed number of wrappings is made on a bale and the turntable is stopped in unloading position. Wrapping can be stopped at any time by pressing **START | STOP** key.

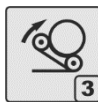

Raise the turntable using key (16). Keep the key held down while raising the turntable.

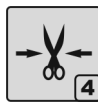

Using key (18), extend the cylinder rod in order to grip the film. Keep the key held down while extending the cylinder rod.



Lower the turntable using key (17). Keep the key held down while lowering the turntable.



Press and release key (14). Set the turntable in loading position.

After a completed wrapping cycle, the message containing statistical data is shown on the display. Quantity of wrapped bales is increased by 1 and the number of wrappings is zeroed.





BALES L-05: 25
WRAPES: 24>0

If bale wrapping is interrupted, the current counter of wrappings can be reset by pressing **F1** key.



DELETE NUMBER
OF WRAPS?

Resetting is confirmed by pressing **ENTER**  key. If **ESC**  key is pressed, the previous status is restored and the counter is not reset.

TIP



*If wrapping is interrupted by pressing **START | STOP** key, it is possible to continue wrapping after pressing key (15). When the key is pressed, wrapping will be continued until a programmed number of wrappings is made. Instead of pressing key (15), it is possible to press and hold down key (14). In this case, wrapping will be continued until the key is released.*

Should it be necessary to set the turntable in one of the working positions (loading or unloading), press key (14) without holding it down. This happens most frequently in case of emergency stop or if the machine is stopped by pressing **START | STOP** key.

B.3.5 OPERATION IN SEMI-AUTOMATIC MODE.



Press F2 key.

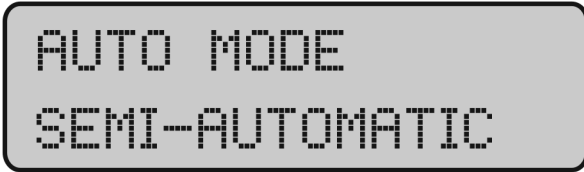

Using + key or – key, choose the following option:

AUTO MODE

SEMI-AUTOMATIC



Press **AUTO** | **MAN** key. Start of semi-automatic mode is signalled by lighting up the green diode.



After start of semi-automatic mode, the following message is displayed:

AUTO LOADING

PRESS START



When **START** | **STOP** key is pressed, loading will be carried out and confirmed by the following message:

AUTOMATIC BALE LOADING.

After completed loading, the following message will appear:

AUTO WRAPPING

PRESS START



When **START** | **STOP** key is pressed, wrapping will start. During wrapping, the message indicating the number of unloaded bales and current number of wrappings for a given working field is displayed.





AUT. UNLOADING
PRESS START

After completed wrapping, the turntable will be positioned for unloading. The following message will be displayed:

AUTO UNLOADING

PRESS START



END BALE
WRAPPING CYCLE

When **START** | **STOP** is pressed, the turntable will be raised and a bale will be unloaded. Status of the counter of ready bales will be increased by 1 and the number of wrappings will be reset. After lowering, the turntable will be positioned for loading a next bale.

Semi-automatic mode is divided into three stages: auto loading, auto wrapping and auto unloading. Individual stages of semi-automatic mode are activated by pressing **START** | **STOP** key (green LED next to **START** | **STOP** key lights up). The activity to be performed after pressing the key is indicated by a proper message on the display:

B.3.6 STOPPING AND RESTARTING IN SEMI-AUTOMATIC MODE

STOPPING

Each activity can be interrupted by pressing **START | STOP** key or **AUTO | MAN** key. If any of the keys is pressed, the bale wrapper operation will be stopped and manual operation mode will be activated (LED located next to **AUTO | MAN** key will go out). Also, if the bale wrapper is stopped because of the film breaking, the corresponding message will be displayed and manual mode will be activated.

STARTING

Manual mode is activated in case of a forced stop of the bale wrapper operation. In order to continue operation in semi-automatic mode, press **AUTO | MAN** key. Next, press F1 key and, using + key and – key, choose the operation that has to be restarted. If **ESC** key is pressed before **ENTER** key, the previous setting is activated.

The manual mode keys are not active while an activity is being performed in automatic mode.

B.3.7 OPERATION IN AUTOMATIC MODE.



Press F2 key.

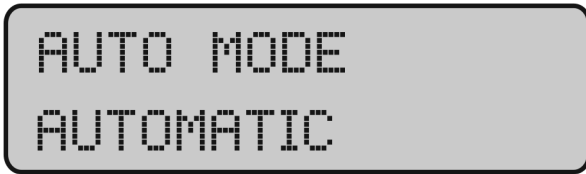

Using + key or – key, choose the following option:

AUTO MODE

AUTOMATIC



Press **AUTO** | **MAN** key. Start of automatic mode is signalled by lighting up the green diode.



After start of automatic mode, the following message is displayed:

AUT. LOADING

PRESS START



When **START** | **STOP** key is pressed, loading will be carried out and confirmed by the following message:

AUTOMATIC BALE LOADING.



When **START** | **STOP** key is pressed, wrapping will start. During wrapping, the message indicating the number of unloaded bales and current number of wrappings for a given working field is displayed.

AUT. UNLOADING
PRESS START

After completed wrapping, the turntable will be positioned for unloading. The following message will be displayed:

AUT. UNLOADING

PRESS START

END BALE
WRAPPING CYCLE

When **START** | **STOP** is pressed, the turntable will be raised and a bale will be unloaded. Status of the counter of ready bales will be increased by 1 and the number of wrappings will be reset. After lowering, the turntable will be positioned for loading a next bale.

The automatic mode is divided into two stages: auto loading and auto unloading. The individual stages of the automatic mode are activated by the **START** | **STOP** button (green LED at the **START** | **STOP** button is lit). The action to be taken after pressing the button is displayed in the corresponding message on the display.

B.3.8 MESSAGES INDICATING COLLISION CONDITIONS

The controller protects the bale wrapper against mechanical damage that may result from collisions of the wrapper's moving parts. A collision condition is indicated by a proper message and inability to perform an activity which may lead to a collision.

SET THE TABLE
FOR LOADING

In order to perform the activity, set the turntable in loading position.

SET THE TABLE
FOR UNLOADING

In order to perform the activity, set the turntable in unloading position.

TO START
LOWER THE ARM!!

In order to perform the activity, lower the loading arm.

TO START
LOWER THE TABLE

In order to perform the activity, lower the turntable.

B.4 SETTING THE BALE WRAPPER'S OPERATING PARAMETERS

CHOOSING A MENU ITEM



Press **AUTO | MAN** key. Set the bale wrapper in **MANUAL** mode. Operating parameters of the bale wrapper can be modified only in manual mode.



Press **MENU** key.



Press **F1** key or **F2** key in order to select a proper item in the menu.



Confirm the selection using **ENTER** key.

RESETTING THE BALE COUNTER



Using **F1** key or **F2** key, choose the following:

MENU:

RESETTING THE BALE COUNTER

Press **ENTER** key

When the following message is displayed:

RESET THE COUNTER

L-XX?? YYY



confirm the selection using **ENTER** key or cancel the selection using **ESC** key.

xx – number of the counter to be reset (working field)

yyy – quantity of bales



Confirm the selection, the counter will be reset. Working time on a given working field is reset simultaneously with the quantity of bales. Exit the menu.

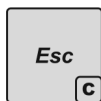

Cancel the selection, the counter will not be reset. Back to the menu.

SELECTING THE BALE COUNTER (WORKING FIELD)

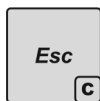
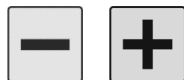

Using **F1** key or **F2** key, choose the following:

MENU:

SELECTING THE BALE COUNTER

Press **ENTER** key

After confirmation, the following message will be displayed:

CHOOSE DAILY COUNTER I-XX

xx – number of a currently selected counter (working field).

Counter number (working field number) should be changed using + key or – key. 16 counters are available (1-16).

Confirm the selection, the selected counter will be set. Exit the menu.

Cancel the selection, the counter will not be selected. Back to the menu.

SETTING THE QUANTITY OF WRAPPINGS



Using **F1** key or **F2** key, choose the following:

MENU:

SET THE QUANTITY OF wrappings

Press **ENTER** key

After confirmation, the following message will be displayed:

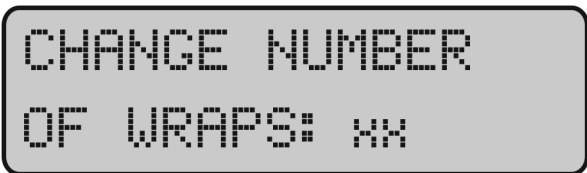

CHANGING THE QUANTITY OF WRAPPINGS: XX.

Available range: 10-99 wrappings.

xx – current quantity of wrappings

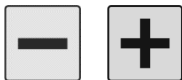

Quantity of wrappings should be changed using + key or – key. Available range: 10-99 wrappings.



Confirm the selection. New value will be stored. Exit the menu.

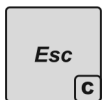

Cancel the selection. New value will not be stored. Back to the menu.

RESETTING THE DATA OF ALL COUNTERS (WORKING FIELDS)



MENU: DELETE
MEMORY



DELETE
ALL DATA?

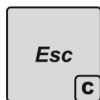

TASK
COMPLETED

Using **F1** key or **F2** key, choose the following:

MENU:

RESETTING THE COMPLETE MEMORY

Press **ENTER** key

After confirmation, the following message will be displayed:

RESET ALL DATA?

When this activity is performed, quantities of bales and working times of all counters (working fields) will be reset.

Confirm the selection. The memory will be reset. Exit the menu.

Cancel the selection. The memory will not be reset. Back to the menu.

If the selection is confirmed using **ENTER** key, the following message will be displayed:

THE COMMAND WAS COMPLETED

Exit the menu.

SETTING THE CLOCK

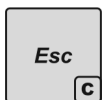
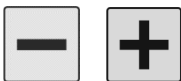
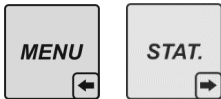

Using **F1** key or **F2** key, choose the following:

MENU:

SET TIME AND DATE

Press **ENTER** key

After confirmation, the message showing currently set time and date will be displayed.

Choose the value to be changed using **MENU** key or **STAT** key. Selected value is underlined

The required value is changed using **+** key and **-**key

Confirm the selection. Date and hour will be set. Exit the menu.

Cancel the selection. Date and hour will not be set. Back to the menu.

If the selection is confirmed using **ENTER** key, the following message will be displayed:

CLOCK IS SET

Exit the menu.

SETTING THE SPEEDS OF MOVEMENTS

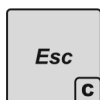
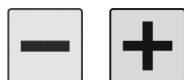
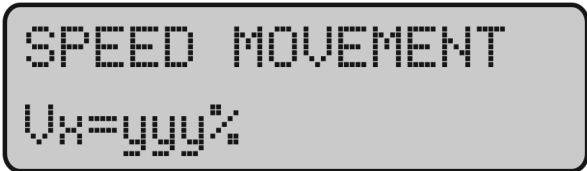

Using **F1** key or **F2** key, choose the following:

MENU:

SET THE SPEED OF MOVEMENTS

Press **ENTER** key

After confirmation, the following message will be displayed:

SPEED OF MOVEMENT

VX=YYY%

Vx – V1...V7 – speed of element to be changed

yyy% - value of speed of movement expressed in percentage within the range of 20-100%

Speed of element V1...V7 is selected using **F1** key and **F2**key

Speed value is changed using **+** key and **-** key

Confirm the selection. The memory will be reset. Exit the menu.

Cancel the selection. The memory will not be reset. Back to the menu.

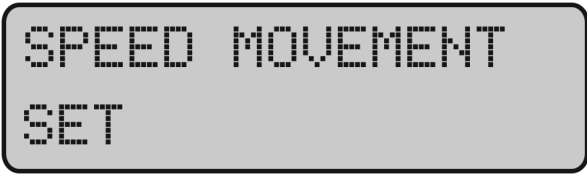

If the selection is confirmed using **ENTER** key, the following message will be displayed:

SPEEDS OF MOVEMENTS ARE SET

Exit the menu.

V1 - loading arm rising speed

V2 - loading arm lowering speed

V3 - turntable rising speed

V4 - turntable lowering speed

V5 - closing speed of the film gripping device (cutting)

V6 - not assigned speed

V7 – rotational speed of the table



TIP

Speeds of individual actuators can be changed within the range from 20 to 100%, every 5%.



ATTENTION

In case when the rotational speed of the V7 table has been set to 90% or higher, this value is changed to default speed of 80% after restarting the controller for user's safety. Lower speeds are not changed.

ACTIVATING THE FILM BREAKING OR FILM END SENSOR

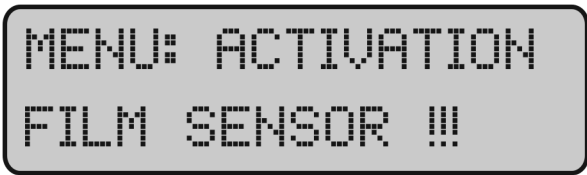

Using **F1** key or **F2** key, choose the following:

MENU: ACTIVATING THE FILM SENSOR



Press **ENTER** key

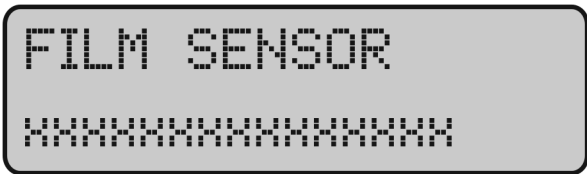

After confirmation, the following message will be displayed: *FILM SENSOR*

XXXXXXXXXX

Where *XXXXXXXXXX* can be active or inactive

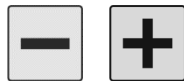

The settings are changed using **+** key and **-** key.



Confirm the selection. New value will be stored. Exit the menu.

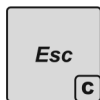

Cancel the selection. Settings will not be changed. Back to the menu.



After activation of the sensor, the following message is displayed if the film is broken:

FILM BREAKING!!!

Wrapping process will be stopped. If any of the keys is pressed, the message will be cancelled.

SELECTING THE CONTROL PANEL LANGUAGE



Using **F1** key or **F2** key, choose the following:

MENU: LANGUAGE SELECTION



Press **ENTER** key

After confirmation, the following message will be displayed:



LANGUAGE

XXXXXXXXXXXXX

Where *XXXXXXXXXXXXX* is the currently set language of the display. Three languages of the menu are available: Polish, English and German.

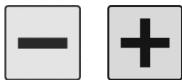

The settings are changed using **+** key and **-** key.



Confirm the selection. A new language will be set. Exit the menu.



Cancel the selection. Language will not be changed. Back to the menu.

B.4.1 STATISTICAL DATA



Press **STAT** key

When the key is pressed, the message containing data on operation of a currently set counter (working field) is displayed.

XX – working field number

YYYY - quantity of wrapped bales for a given counter (working field)

ZZ.Z - capacity defined as quantity of bales wrapped on a given field within one hour

AA - number of working hours for a given field

BB - number of working minutes for a given field

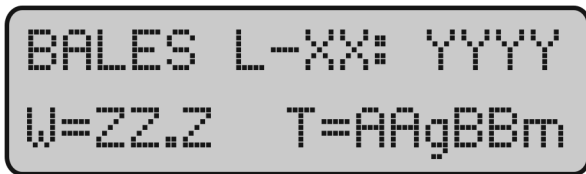

If **STAT** key or **ESC** key is pressed, the main menu will be displayed again



Example



B.4.2 INDICATION OF CURRENT TIME AND DATE



Press **SET** key



When the key is pressed, the message showing current date and time will be displayed. This is the real time indication. The clock is not stopped when the control panel is disconnected from power supply.



If **SET** key or **ESC** is pressed, the main menu will be displayed again.

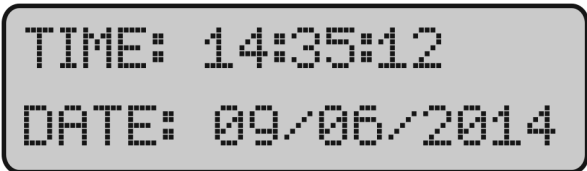

Example

TIP



Working time is counted when the control panel is active. Working time is not counted in transport mode and when the control panel is switched off using ON/OFF key on the control panel or the switch located on the right side of the control panel (the switch is set in "0" position).

B.5 SETTING THE BALE WRAPPER FOR TRANSPORT, TRANSPORT MODE

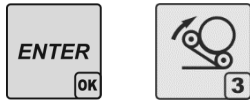

After bale unloading, set the turntable in transport position. Press and hold down **ENTER** key (9) and key (16) for turntable rising.



Raise the loading arm using key (12).

Raise the unloading table to transport position – see the Operator's Manual.

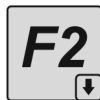

Press **F2** key (11).

TRANSPORT
POSITION

Press **+** key or **-** key in order to choose Transport position option from the menu.

