



PRONAR SP. Z O.O.

17-210 NAREW, UL. MICKIEWICZA 101A, PODLASKIE PROVINCE, POLAND

PHONE: +48 085 681 63 29

+48 085 681 64 29

+48 085 681 63 81

+48 085 681 63 82

FAX: +48 085 681 63 83

+48 085 682 71 10

www.pronar.pl

OPERATOR MANUAL

MULTI-FUNCTION ARM

PRONAR WWT604K / WWT608K

TRANSLATION OF THE ORIGINAL COPY OF THE MANUAL

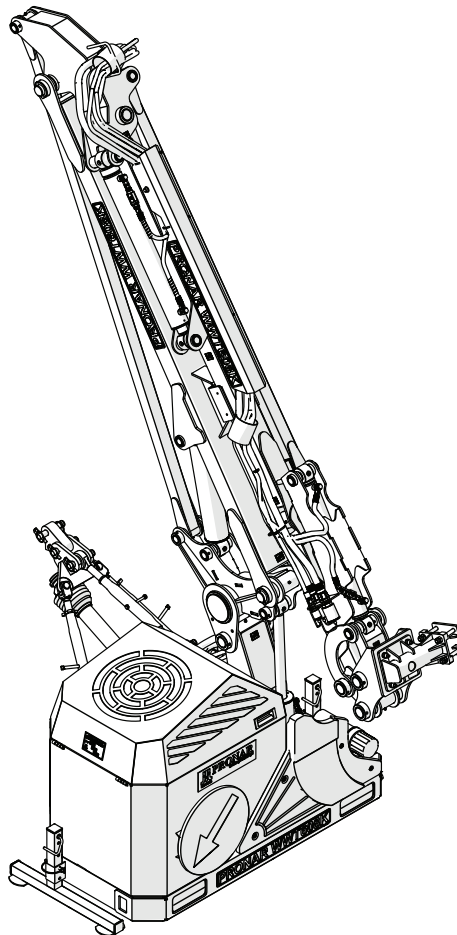

EDITION: 1A-07-2021

PUBLICATION NO.: 616N-00000000UM



INTRODUCTION

1.1 INTRODUCTION

Information in this document is current at date of publication. As a result of improvements, some numerical values and illustrations in this publication may not correspond to the actual specification of the machine supplied to the user. The manufacturer reserves the right to introduce design changes in machines produced that facilitate and improve the quality of machine operation, without making minor amendments to this Operator Manual.

This Operator Manual is an integral part of the machine documentation. Before using the machine, the user must carefully

read this Operator Manual and observe all recommendations. This guarantees safe operation and ensures failure-free work of the machine. The machine is designed to meet obligatory standards, documents and legal regulations currently in force.

If the information in this Operator Manual needs clarification, refer for assistance to the sale point where the machine was purchased or to the Manufacturer.

It is recommended that the serial numbers of the machine and major subassemblies are inscribed in the spaces below after purchase of the machine.

B.2.5.28.01.1.EN

Machine serial number

--	--	--	--	--	--	--	--	--	--	--	--	--	--	--	--	--	--	--	--

1.2 SYMBOLS APPEARING IN THIS OPERATOR MANUAL

DANGER

Information, descriptions of danger and precautions as well as recommendations and prohibitions associated with the safety of use are marked in the text with the sign **DANGER**. Failure to observe the instructions may endanger the machine operator's or other person's health or life.

ATTENTION
Vital information and instructions that must be observed are highlighted by a border and accompanied by the text: **IMPORTANT**
Failure to observe the instructions may lead to damage to the machine as a result of improper operation, adjustment or use.

TIP

Additional tips included in the Operator Manual describe useful advice for the machine operation and are marked with the sign **TIP**.

DIRECTIONS USED IN THIS OPERATOR MANUAL

Left side – side to the left hand of the operator facing in the direction of machine's forward travel.

Right side – side to the right hand of the operator facing in the direction of machine's forward travel.

Rotation to the right – clockwise rotation of a mechanism (the operator is facing the mechanism).

Rotation to the left – counterclockwise rotation of a mechanism (the operator is fac-



DANGER



IMPORTANT



TIP

ing the mechanism).

B.2.5.28.02.1.EN



PRONAR Sp. z o.o.

ul. Mickiewicza 101 A
17-210 Narew, Polska

tel./fax (+48 85) 681 63 29, 681 63 81, 681 63 82,
681 63 84, 681 64 29

fax (+48 85) 681 63 83

http://www.pronar.pl

e-mail: pronar@pronar.pl

EC DECLARATION OF CONFORMITY OF THE MACHINERY

PRONAR Sp. z o.o. declares with full responsibility, that the machine:

Description and identification of the machinery		
Generic denomination and function:	Multifunction arm	
Type:	WWT604K	WWT608K
Model:	—	—
Serial number:		
Commercial name:	Multifunction arm PRONAR WWT604K Multifunction arm PRONAR WWT608K	

to which this declaration relates, fulfills all the relevant provisions of the Directive **2006/42/EC** of The European Parliament and of The Council of 17 May 2006 on machinery, and amending Directive 95/16/EC (Official Journal of the EU, L 157/24 of 09.06.2006).

The person authorized to compile the technical file is the Head of Research and Development Department at PRONAR Sp. z o.o., 17-210 Narew, ul. Mickiewicza 101A, Poland.

This declaration relates exclusively to the machinery in the state in which it was placed on the market, and excludes components which are added and/or operations carried out subsequently by the final user.

Narew, the 2021-08-12

Place and date

Z-CA DYREKTORA
d/s technicznych
członek zarządu

Roman Smelaniuk

PRONAR Spółka z o.o.
17-210 Narew ul. Mickiewicza 101A
Tel. (85) 681 63 29, 682 72 54
Fax: (85) 681 63 83
NIP 543 62 10 935; KRS 0000139188
BDO 006014169

Full name of the empowered person
position, signature

TABLE OF CONTENTS

INTRODUCTION

1.1	INTRODUCTION	2
1.2	SYMBOLS APPEARING IN THIS OPERATOR MANUAL	3

BASIC INFORMATION

1.1	IDENTIFICATION	1.2
1.2	INTENDED USE	1.3
1.3	EQUIPMENT	1.5
1.4	TERMS & CONDITIONS OF WARRANTY	1.6
1.5	TRANSPORT	1.7
1.6	ENVIRONMENTAL RISK	1.9
1.7	WITHDRAWAL FROM USE	1.10

SAFETY ADVICE

2.1	SAFE USE	2.2
2.2	SAFETY WHEN HITCHING THE MACHINE	2.4
2.3	SAFETY RULES WHEN MAINTAINING HYDRAULIC SYSTEM.	2.5
2.4	SAFETY DURING TRANSPORT TRAVEL	2.6
2.5	MAINTENANCE	2.7
2.6	SAFETY DURING MULTIFUNCTION ARM OPERATION	2.9
2.7	SAFE OPERATION OF THE PTO SHAFT	2.11
2.8	RESIDUAL RISK	2.12
2.9	INFORMATION AND WARNING DECALS	2.13

DESIGN AND OPERATION

3.1	TECHNICAL SPECIFICATION	3.2
3.2	DESIGN AND OPERATION	3.6

CORRECT USE

4.1	PREPARE FOR WORK	4.2
4.2	HITCHING THE MULTIFUNCTION ARM TO THE CARRIER VEHICLE (TRACTOR)	4.4
4.3	BALLASTING THE CARRIER VEHICLE (TRACTOR)	4.9
4.4	STARTING AND CONTROLLING THE MULTIFUNCTION ARM	4.12
4.5	ATTACHING THE WORKING HEAD	4.15
4.6	TRANSPORTING THE MACHINE	4.17
4.7	SETTING THE MULTIFUNCTION ARM IN WORKING POSITION AND OPERATION	4.19

MAINTENANCE

5.1	TECHNICAL INSPECTION	5.2
5.2	HYDRAULIC SYSTEM MAINTENANCE	5.3
5.3	ELECTRICAL SYSTEM MAINTENANCE	5.9
5.4	LUBRICATION	5.10
5.5	TIGHTEN BOLT CONNECTIONS	5.12
5.6	STORAGE	5.13
5.7	TROUBLESHOOTING	5.14

SECTION 1

BASIC INFORMATION

1.1 IDENTIFICATION

PRONAR WWT604K / WWT608K multifunction arms are marked with rating plates located on the lower part of the multifunction arm's frame (FIGURE 1.1). When purchasing the machine, make sure that the serial numbers on the machine are the same as entered in the *Warranty Book*, in sales documents and in the *Operator Manual*.

The meaning of individual items of the nameplate – (FIGURE 1.1) are presented in the table below:

- A - machine name,
- B - machine type/symbol
- C – serial number,
- D – year of manufacture,
- E – gross weight [kg],
- F - Quality Control stamp,
- G – machine name, name extension

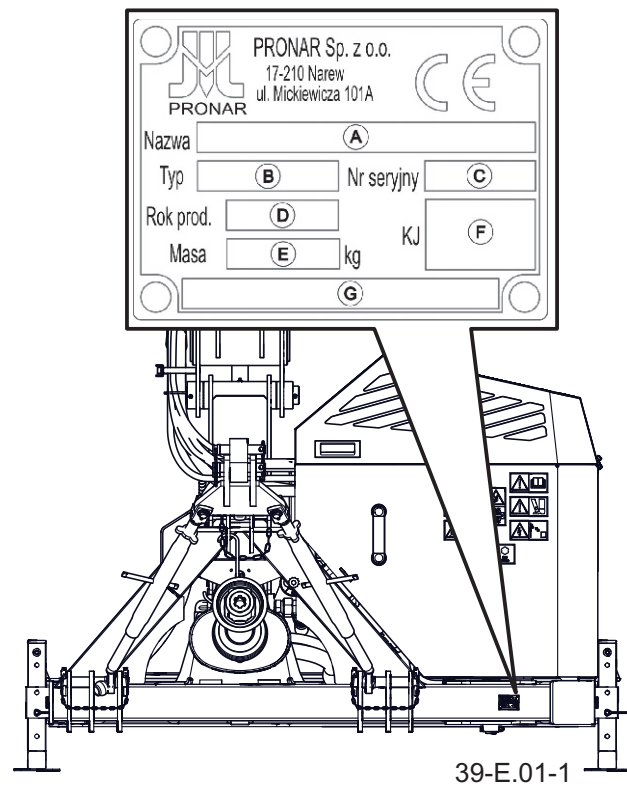

Figure 1.1 Location of the nameplate.

E.2.5.616.01.1.EN

1.2 INTENDED USE

PRONAR WWT604K / WWT608K multifunction arm is designed and constructed according to current safety and engineering standards.

PRONAR WWT604K / WWT608K multifunction arms are designed to work with working head adjusted to such a type of arm.

The multifunction arm with a working head is designed for the maintenance of municipal infrastructure, urban greenery, orchards and wooded areas and for agricultural works. It could be used for maintaining grass and hedges, trimming branches and boughs, cleaning field drains and for maintaining road infrastructure. Exact intended purpose of the multifunction arm-working head set is described in the Operator Manual of a given working head. The multifunction arm's jointed and telescopic design and its far reach enables the operator to carry out works in hard-to-access places such as roadside ditches behind safety barriers, slopes and field drains.

Transporting people, animals or other materials is prohibited and regarded as contrary to the intended purpose. During the use of the machine comply with all road traffic regulations and transport regulations in force in the given country, and any

breach of these regulations is regarded by the Manufacturer as use contrary to the intended use of the machine.

Using it as intended involves all actions connected with the safe and proper operation and maintenance of the machine.

Due to the above, the user is obliged to:

- carefully read the *Operator Manual*



NOTE

The multifunction arm must not be used for purposes other than those for which it is intended, in particular:

- for transporting people and animals,
- for transporting whatever materials or objects.

and comply with its recommendations,

- understand the machine's operating principle and how to operate it safely and correctly,
- adhere to the established maintenance and adjustment plans,
- comply with general safety regulations while working,
- prevent accidents,
- comply with the road traffic regulations and transport regulations in force in the given country, in which the machine is used,
- carefully read the carrier vehicle's Operator Manual and comply with its

recommendations.

The multifunction arm may only be used by persons, who:

- are familiar with this publication and the operating instructions of the implement carrier,
- have been trained in the multifunction arm safe operation,
- have the required authorisation to drive the carrier vehicle and are familiar with the road traffic regulations and transport regulations.

E.2.5.616.02.1.EN

Table 1.1 Requirements for carrier vehicle (agricultural tractor).

Contents	Unit	Requirements
Carrier vehicle's (tractor's) three-point linkage		Rear three-point linkage of category III according to ISO 730 or III according to ISO 730-1 standard
Rear power take-off shaft (PTO) Type Rotation speed Number of splines on PTO shaft Rotation direction	- rpm pc. -	Type 1 (1 3/8") acc. to ISO 730-1 540 6 clockwise (operator facing the carrier vehicle's driving direction)
Electric sockets	-	3-pin socket, 12V (power supply of cooler fan) 7-pin socket, 12V (power supply for rear lamp assembly)
Other requirements Minimum carrier vehicle's weight	kg	5500

1.3 EQUIPMENT

Table 1.2 Equipment of multifunction arm PRONAR WWT604K / WWT608K

Equipment	
<i>Operator Manual</i>	S
<i>Warranty Book</i>	S
Drive shaft 5R 502 4 BA 502	O
Working head connection TYPE 80	S
Working head connection TYPE 60	O

Equipment: Sstandard; Ooptional

E.2.5.616.03.1.EN

1.4 TERMS & CONDITIONS OF WARRANTY

PRONAR Sp. z o.o. Narew guarantees the reliable operation of the machine when it is used according to its intended purpose as described in the *Operator Manual*. Defects discovered during the warranty period will be removed by the Warranty Service. The repair period is specified in the *Warranty Book*.

The warranty does not cover those parts and sub-assemblies of the machine which are subject to wear in normal usage conditions, regardless of the warranty period.

Consumables include the following parts/sub-assemblies:

- bulbs,
- seals,
- bearings,

The warranty service only applies to such cases as: mechanical damage which is not the user's fault, factory defects of parts, etc.

In the event of damage arising from:

- mechanical damage which is the user's fault, damage caused by road accidents,
- incorrect use, adjustment or maintenance, use of the machine for purposes other than those for which it is intended,
- use of damaged machine,

- repairs carried out by unauthorised persons, repairs carried out improperly,
- making unauthorised alterations to machine design,

the user will lose the right to warranty



Demand that the seller carefully and accurately fills out the *Warranty Book* and warranty repair coupons. A missing date of purchase or sale point stamp may make the user ineligible for any warranty repair or refund.

service.

The user is obliged to report immediately on noticing any wear in the paint coating or traces of corrosion, and to have the faults rectified whether they are covered by the warranty or not. For detailed Terms & Conditions of Warranty, please refer to the *Warranty Book* attached to each newly purchased machine.

Modification of the multifunction arm without the written consent of the Manufacturer is prohibited. In particular, do NOT weld, drill holes in, cut or heat the main structural elements of the machine, which have a direct impact on the machine operation safety.

E.2.5.28.04.1.EN

1.5 TRANSPORT

The multifunction arm is ready for sale completely assembled and does not require packing. Packing is only required for the machine's technical documentation and any controls (joystick) or extra accessories.

Delivery is either by transport on a vehicle

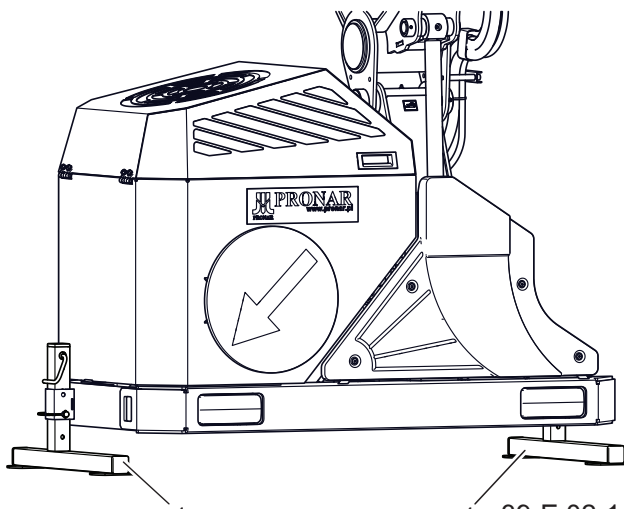

Figure 1.2 Support feet of multifunction arm during loading.

(1)- support feet.

or independently. Transport of the machine is permissible connected to a carrier vehicle provided the vehicle's driver familiarises himself with the multifunction arm's Operator Manual and particularly with information concerning safety and principles of hitching and transport on public roads. Do NOT drive the vehicle with the multifunction arm hitched when visibility is limited.

When loading and unloading the multifunction arm, follow the general health and safety regulations for reloading work.

TIP

During loading, the multifunction arm should be placed in transport position, without the working head. (FIGURE 4.7)

Persons operating reloading equipment must have the qualifications required to operate these machines.

During loading and transportation the multifunction arm should stand on support feet (1) (FIGURE 1.2) extended and locked on both sides of the arm at the same height.

The multifunction arm should be firmly secured on the transport vehicle platform with belts or chains equipped with a tensioning mechanism. The fastening equipment

NOTE

When transporting the machine independently, the carrier vehicle driver must carefully read this Operator Manual and observe all its instructions. When being transported on a motor vehicle the multifunction arm must be mounted on the vehicle's platform in accordance with the transport safety requirements. The driver of the vehicle should use extreme caution while driving. This is due to the vehicle's centre of gravity shifting upwards when the machine is loaded.

**IMPORTANT**

Do NOT secure lifting slings or any types of securing elements to hydraulic cylinders.
Nobody may be in the manoeuvring zone when transferring the machine to another means of transport.

used must have a valid safety certificate. Exercise due caution when lifting the machine. During reloading work, special care should be taken not to damage the paint coating.

E.2.5.616.05.1.EN

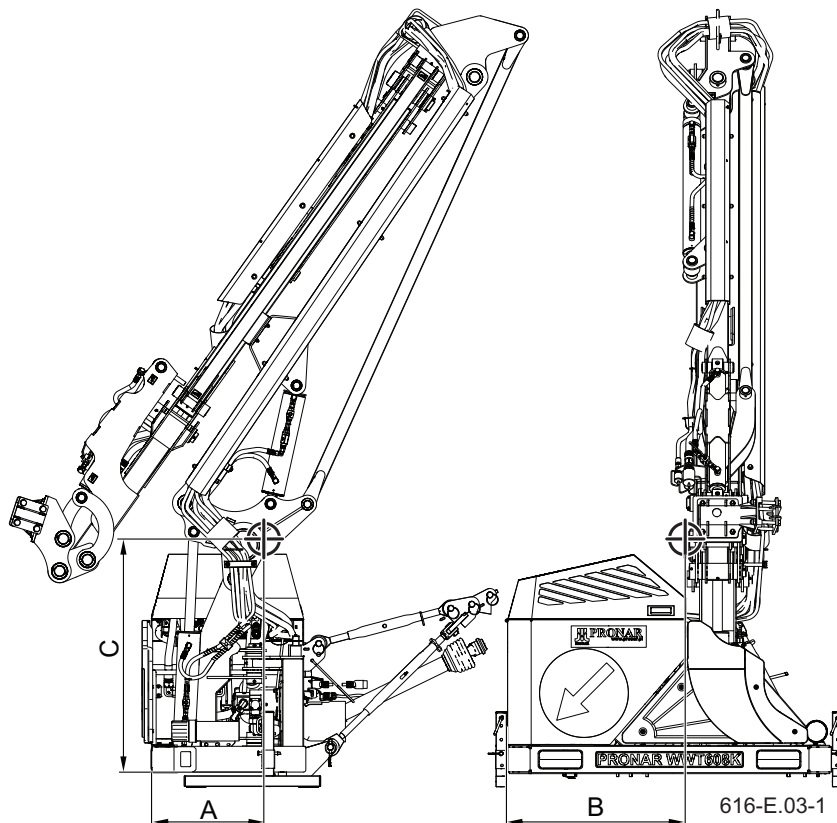

Figure 1.3 Location of the centre of gravity of the multifunction arm in transport position on the carrier vehicle (tractor). Machine with hydraulic oil in the tank.

Table 1.3 Centre of gravity.

Dimension	Unit	WWT604K / WWT608K
A	mm	1080
B	mm	775
C	mm	1085

1.6 ENVIRONMENTAL RISK

A hydraulic oil leak constitutes a direct threat to the natural environment owing to its limited biodegradability. While carrying out maintenance and repair work, which involves the risk of an oil leak, this work should take place on an oil resistant floor or surface. In the event of oil leaking into the environment, first of all contain the source of the leak, and then collect the leaked oil using available means. Remaining oil should be collected using sorbents, or by mixing the oil with sand, sawdust or other

absorbent materials. The oil contaminations, once gathered up, should be kept in a sealed, marked, hydrocarbon resistant container, and then passed on to the appropriate oil waste recycling centre. The container should be kept away from heat sources, flammable materials and food.

Oil which has been used up or is unsuitable for further use owing to loss of its properties should be stored in its original packaging in the conditions described above.

E.2.5.28.06.1.EN

1.7 WITHDRAWAL FROM USE

Should you decide to withdraw the machine from use, comply with the regulations in force in the given country regarding withdrawal from use and recycling of machines withdrawn from use.

Before proceeding to dismantle equipment, oil shall be completely removed from hydraulic system and transmission. Locations of drain plugs and method for draining oil are described in Section 5.

When spare parts are changed, worn out

or damaged parts should be taken to a collection point for recyclable raw materials. Used oil and also rubber and plastic elements should be taken to the appropriate facilities dealing with the recycling of this type of waste.



DANGER

During dismantling, use the appropriate tools, equipment (overhead crane, crane or hoist etc.) and use personal protection equipment, i.e. protective clothing, footwear, gloves and eye protection etc.

E.2.5.28.07.1.EN

SECTION 2

SAFETY ADVICE

2.1 SAFE USE

- Before use, the user must carefully read this Operator Manual and the *Warranty Book*. When operating the machine, follow all instructions in these documents.
- The multifunction arm may only be used and operated by persons qualified to drive carrier vehicles (tractors) and trained in machine operation. The multifunction arm can be operated by a single person only.
- If the information in this Operator Manual is difficult to understand, contact the seller who runs the authorised technical service on behalf of the Manufacturer, or contact the Manufacturer directly.
- Careless and improper use and operation of the machine, and failure to comply with the instructions of this operator manual is dangerous to your health.
- Be aware of the residual risk. Use caution when operating this multifunction arm and apply all relevant safety principles.
- The machine must never be used by persons, who are not authorised to drive carrier vehicles (agricultural tractors), including children and people under the influence of alcohol or other drugs.
- Non-compliance with the safety rules of this Operator's Manual can be dangerous to the health and life of the operator and others.
- The machine must not be used for purposes other than those for which it is intended. Anyone who uses the multifunction arm other than the way intended takes full responsibility for himself for any consequences of this use. Use of the machine for purposes other than those for which it is intended by the Manufacturer may invalidate the guarantee.
- The multifunction arm may only be used when all the safety guards and other protective elements are technically sound and correctly positioned. In the event of loss or damage to the protective guards, they must be replaced with new ones.
- Do NOT operate the multifunction arm with the carrier vehicle (tractor) without the driver's cab. The carrier vehicle (tractor) should be equipped with the cab protecting the operator against possible hazards. The operator should also use personal

protective equipment such as protective clothing, safety goggles, safety helmet to reduce the risk of injuries.

- In order to limit occupational risks associated with exposure to noise

during multifunction arm operation use individual protection (hearing protectors). In order to reduce the level of noise during work, the operator cab windows and door should be closed.

F.2.5.28.01.1.EN

2.2 SAFETY WHEN HITCHING THE MACHINE

- Do not hitch the multifunction arm to the carrier vehicle (tractor) if the linkage systems of the multifunction arm and the carrier vehicle (tractor) are not compatible.
- Only the rear linkage of the carrier vehicle (agricultural tractor) should be used for hitching the machine with the carrier vehicle (agricultural tractor). After hitching the machine, check the safeguards. Carefully read the Operator Manual of the carrier vehicle (agricultural tractor).
- Use only genuine pins and safeguards to hitch the machine to the carrier vehicle (agricultural tractor)
- The carrier vehicle (agricultural tractor) to which the multifunction arm will be hitched must be technically reliable and must meet the relevant Manufacturer requirements.
- Be especially careful when hitching the machine.
- When hitching, there must be nobody between the multifunction arm and the carrier vehicle (agricultural tractor).
- Unhitching the multifunction arm from the carrier vehicle (agricultural tractor) is prohibited when the working head is raised. Exercise caution when unhitching the machine.
- Coupling and uncoupling may only take place when the machine and tractor (carrying vehicle) are turned off.
- Multifunction arm unhitched from the carrier vehicle (tractor) must be secured against overturning and supported on a stable and level surface.

F.2.5.28.02.1.EN

2.3 SAFETY RULES WHEN MAINTAINING HYDRAULIC SYSTEM.

- The hydraulic system is under high pressure when operating.
- Regularly check the technical condition of the hydraulic lines and connections. There must be no oil leaks.
- In the event of the hydraulic system malfunction, discontinue using the machine until the malfunction is corrected.
- When connecting the hydraulic lines to the working head, make sure that the hydraulic system of the multi-function arm is not under pressure. If necessary, reduce residual pressure in the system.
- In the event of injuries being caused by pressurised hydraulic oil, contact a doctor immediately. Hydraulic oil may find its way under the skin and cause infections. In the event of contact of oil with eye, rinse with large quantity of water and in the event of the occurrence of irritation consult a doctor. In the event of contact of oil with skin wash the area of contact with water and soap. Do NOT apply organic solvents (petrol, kerosene).
- Use the hydraulic oil recommended by the Manufacturer. Never mix two types of oil.
- After changing the hydraulic oil, the used oil should be properly disposed of. Used oil or deteriorated oil should be stored in original containers or replacement containers resistant to hydrocarbons. Replacement containers must be clearly marked and appropriately stored.
- Do not store hydraulic oil in packaging designed for storing food or foodstuffs.
- Rubber hydraulic lines must be replaced every 4 years regardless of their technical condition.
- Repair and replacement of hydraulic system elements should be entrusted to the appropriately qualified persons.

F.2.5.28.03.1.EN

2.4 SAFETY DURING TRANSPORT TRAVEL

- When driving on public roads, observe all road traffic regulations in force in the country, in which the machine is used.
- Do not exceed the maximum speed resulting from road conditions and design restrictions. Adjust speed to the prevailing road conditions and other limitations arising from road traffic regulations.
- Before beginning travel, the multifunction arm must be folded to transport position.
- Do NOT leave working head raised and unsecured while the carrier vehicle (agricultural tractor) is parked. When parked, the working head should be lowered.
- Do not transport the multifunction arm set in the working position.
- The multifunction arm may not be used or transported in conditions of limited visibility.
- Do NOT ride on the machine or transport any materials on it.
- Before using the machine always check its technical condition, especially in terms of safety. In particular, check the technical condition of the linkage and the hydraulic system connections.
- Reckless driving and excessive speed may cause accidents.

F.2.5.28.04.1.EN

2.5 MAINTENANCE

- During the warranty period, any repairs may only be carried out by warranty service authorised by the Manufacturer. It is recommended that necessary repairs to machine should be undertaken by specialised workshops.
- In the event of any fault or damage, do not use the multifunction arm until the fault has been corrected.
- During work, use appropriate, close-fitting protective clothing, gloves and appropriate tools. When working on hydraulic systems it is recommended to use oil resistant gloves and protective goggles.
- Any modification to the multifunction arm frees PRONAR Narew from any responsibility for damage or detriment to health, which may arise as a result.
- Before commencing any work on the multifunction arm, turn off the carrier vehicle (tractor) engine and wait until all rotating parts have come to a stop.
- Regularly check the technical condition of the safety devices and correct tightening of bolt connections.
- Regularly perform service inspections of machine as recommended by the Manufacturer.
- Do NOT perform maintenance or repair work under raised and unsupported machine.
- Before beginning repairs on hydraulic systems, reduce oil pressure.
- Servicing and repair work should be carried out in line with the general principles of workplace health and safety. In the event of injury, the wound must be immediately cleaned and disinfected. In the event of more serious injuries, seek a doctor's advice.
- Repair, maintenance and cleaning work should be carried out with the carrier vehicle (agricultural tractor) engine turned off and the ignition key removed. Immobilise the carrier vehicle (agricultural tractor) with parking brake. Ensure that unauthorised persons do not have access to the carrier vehicle (agricultural tractor) cab.
- Should it be necessary to change individual parts, use only original parts. Non-adherence to these requirements may put the user and other people's health and life at risk, and also damage the machine and invalidate the warranty.
- Regularly check technical condition

and mounting of all guards and protective elements.

- In the event of work requiring the multifunction arm to be raised, use properly certified hydraulic or mechanical lift jacks for this purpose. After lifting the machine, stable and durable supports must also be used. Do NOT carry out work under a machine, which has been raised only

with the three point linkage.

- The machine must not be supported using fragile elements (bricks or concrete blocks).
- After completing work associated with lubrication, remove excess oil or grease.
- In order to reduce the danger of fire the machine must be kept in a clean condition.

F.2.5.28.05.1.EN

2.6 SAFETY DURING MULTIFUNCTION ARM OPERATION

- Before starting the multifunction arm, make sure that there are no bystanders (especially children) or animals in the danger zone. The machine operator is obliged to ensure proper visibility of the machine and the working area.
- Before starting the working head drive, lower the working head to working position.
- Multifunction arm operation should begin after reaching nominal PTO speed of 540 rpm. Do NOT overload the multifunction arm's hydraulic system and also do NOT engage the PTO suddenly.
- Do NOT leave the carrier vehicle (agricultural tractor) cab, when the machine drive is engaged.
- Do NOT stand within the multifunction arm's working zone.
- Do NOT operate the working head while reversing. Raise the machine while reversing.
- Keep a safe distance from electric power lines during travel with raised multifunction arm.
- All the control panel operations should be performed only from the operator's seat in the carrier vehicle's (agricultural tractor's) cab. Operating the control panel outside the operator's cab is prohibited.
- Start folding the multifunction arm to the transport position by retracting the inner (telescopic) arm.
- Do NOT operate the multifunction arm with a carrier vehicle (tractor) which has a complete vehicle kerb weight smaller than 5500 kg.
- Operation and transport of the multifunction arm is allowed only on slopes with the maximum inclination of 7°. However, due to changing location of centre of gravity depending on type of working head, type of carrier vehicle (tractor) and length of multifunction arm, the allowable slope inclination angle may be smaller. That is why the user must exercise particular caution and determine by himself the maximum slope inclination angle for operating the multifunction arm.
- If the full reach of the multifunction arm is to be used, make sure that stability of the carrier vehicle (agricultural tractor) will be maintained.
- While working on slopes, do not raise the working head more than 0,5 m above the ground.

- In the event of a tilt of the carrier vehicle (agricultural tractor) with the multifunction arm, immediately lower the working head to the ground and stop the carrier vehicle (agricultural tractor).

F.2.5.28.06.1.EN

2.7 SAFE OPERATION OF THE PTO SHAFT

- While reversing and during turns, the PTO drive must be disengaged.
- The machine may only be connected to the carrier vehicle (tractor) by means of an appropriately selected PTO shaft recommended by the Manufacturer.
- Adjust the length of PTO shaft to compatible carrier vehicle (tractor) according to the Operator Manual of PTO shaft.
- The PTO shaft has markings on the casing, indicating which end of the shaft should be connected to the carrier vehicle (tractor).
- Never use a damaged PTO shaft, it may cause an accident. A damaged shaft must be repaired or replaced.
- Disconnect the shaft drive each time when it is not necessary to drive the machine, or when the carrier vehicle (tractor) and the machine are positioned at an unsuitable angle with regard to each other.
- The chains preventing the shaft cover from turning while the shaft is working, shall be secured to a fixed element of machine structure.
- Do NOT use the securing chains to support the shaft while machine is parked or when transporting the machine.
- Before using the machine, carefully read the PTO shaft Operator Manual and follow all instructions.
- The drive shaft must be equipped with a cover. Do NOT use the shaft with damaged or missing guards.
- After connecting the shaft, ensure that it is correctly and safely connected to the carrier vehicle (tractor) and to the machine.
- Before starting PTO shaft, make certain that the PTO rotation direction is correct.
- Before disconnecting the shaft, turn off the engine of the carrier vehicle (tractor) and remove the key from the ignition.
- Do NOT wear loose clothing, straps or whatever that may become wrapped round the rotating drive shaft. Contact with rotating PTO shaft may cause severe injuries.
- Do NOT go over and under the shaft or stand on it equally during work as also when the machine is parked.

F.2.5.28.07.1.EN

2.8 RESIDUAL RISK

Pronar Sp. z o. o. in Narew has made every effort to eliminate the risk of accidents. There is, however, a certain residual risk, which could lead to an accident, and this is connected mainly with the actions described below:

- using the machine for purposes other than those for which it is intended,
- being between the carrier vehicle (agricultural tractor) and the machine while the engine is running and when the machine is being attached,
- being on the machine while the engine is running,
- operating the multifunction arm with removed or faulty safety guards,
- failure to maintain a safe distance from the danger zone or being within the zones while the machine is operating,
- machine operation by unauthorized persons or persons under the influence of alcohol
- cleaning, maintenance and technical

checks when carrier vehicle (tractor) is connected and engine is running.

The residual risk may be kept to a minimum by following the recommendations below:

- operate the machine in prudent and unhurried manner,
- sensibly apply the remarks and recommendations contained in the Operator Manual,
- carry out repairs and maintenance work in line with operating safety rules,
- repair and maintenance work should be carried out by persons trained to do so,
- use close fitting protective clothing,
- ensure unauthorised persons have no access to the machine, especially children.
- maintain a safe distance from forbidden or dangerous places
- do not climb on the machine when it is operating

F.2.5.28.08.1.EN

2.9 INFORMATION AND WARNING DECALS





The multifunction arm is marked with the information and warning decals specified in Table 2.1. Throughout the machine use, you must ensure that any warning messages and information decals located on the machine are clear and legible. If any are destroyed or damaged, they must be replaced with new. Safety decals can be purchased from the Manufacturer of the

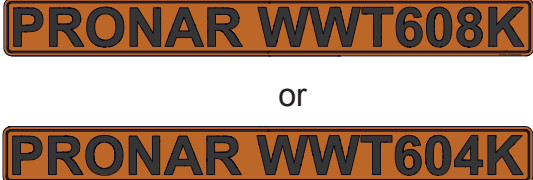
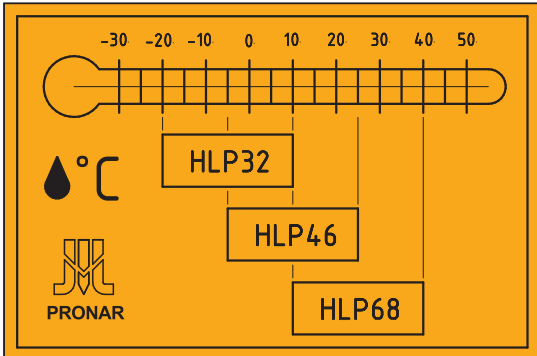

machine or your PRONAR dealer. New assemblies, changed during repair, must be labelled once again with the appropriate safety signs. When cleaning the multifunction arm, do not use solvents that may damage the coating of information decals and do not subject them to action of strong water jets.

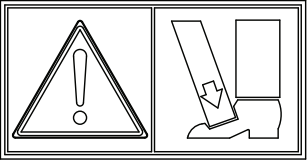
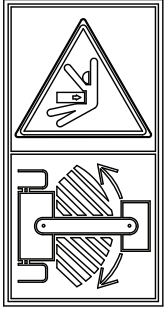
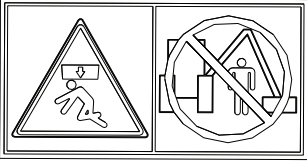
F.2.5.28.09.1.EN

Table 2.1 Information and warning decals

Item	Decal	Meaning
1	 <p>PRONAR WWT608K or PRONAR WWT604K</p>	<p>Machine type 616N-97000001 or 616N-97000003</p>
2	 <p>PRONAR WWT608K or PRONAR WWT604K</p>	<p>Machine type 616N-97000002 or 616N-97000004</p>
3	 <p>Hydraulic oil classification decal</p>	<p>Hydraulic oil classification decal 361N-90010006</p>

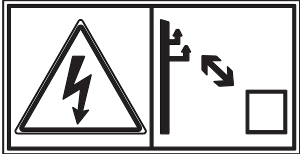
Item	Decal	Meaning
4		<p>Danger of crushing foot or toes. 258N-00000001</p>
5		<p>When implement is in use there must be no bystanders in designated areas. If any work is required in these areas, make sure the carrier vehicle (agricultural tractor) is stationary, and whether the implement is disconnected from the power source. 258N-00000002</p>
6		<p>Danger of being struck. Do not stay within the reach of the multifunction arm and working head. 235N-00000001</p>
7		<p>Decal PRONAR 187N-00000016S</p>
8		<p>Before starting work, carefully read the Operator Manual. 185N-00000001</p>
9		<p>Before maintenance or repairs, turn off engine and remove key from ignition. 185N-00000002</p>

Item	Decal	Meaning
10		<p>Maximum allowable PTO shaft rotation speed is 540 rpm. 185N-00000004</p>
11		<p>Use extreme caution when working near electric power lines. Danger of electric shock. 185N-00000009</p>
12		<p>Lubrication points 185N-00000011</p>
13		<p>Do not reach into crushing space because elements may move. Danger of crushing hands or fingers. 178N-00000005</p>

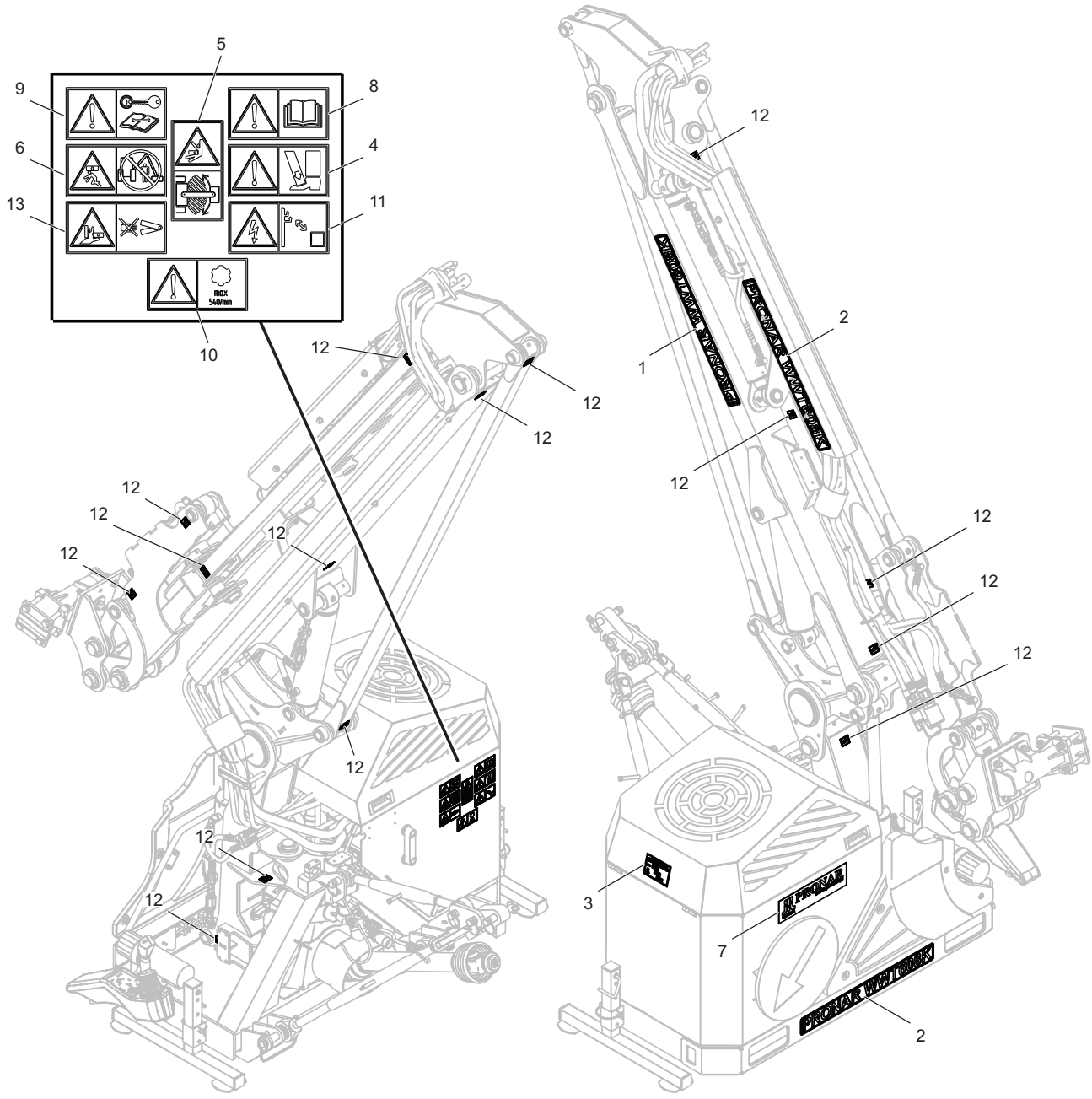

616-F.01-1

Figure 2.1 Locations of information and warning decals.

SECTION 3

DESIGN AND OPERATION

3.1 TECHNICAL SPECIFICATION

Table 3.1 Basic technical data of the standard multifunction arm

Contents	Unit	WWT604K	WWT608K
Dimensions			
Total length in transport setting	m	2.42	
Width in transport setting	m	1.69	
Height in transport setting	m	3.63	
Technical specification			
Multifunction arm drive	-	Hydraulic - own power source	
Multifunction arm control	-	Electrical ON-OFF	Electrical (proportional to the joystick deflection angle)
Working pressure of the hydraulic system	bar	200	
Maximum power of the hydraulic system (head+arm control in total)	kW	40.2	
Oil tank capacity	l	180	
Head rotating angle	°	215	
Multifunction arm rotating angle and hydraulic safety device operating range	°	90	
Arm safeguard	-	Hydraulic safety device	
Oil cooler	-	Standard	
Rear lamp assembly	-	Standard	
Horizontal reach (measured to centre of attachment)	m	5.49	
Multifunction arm position with regard to the carrier vehicle	-	Right	
Weight without a tool (hydraulic system filled with oil)	kg	1,200	

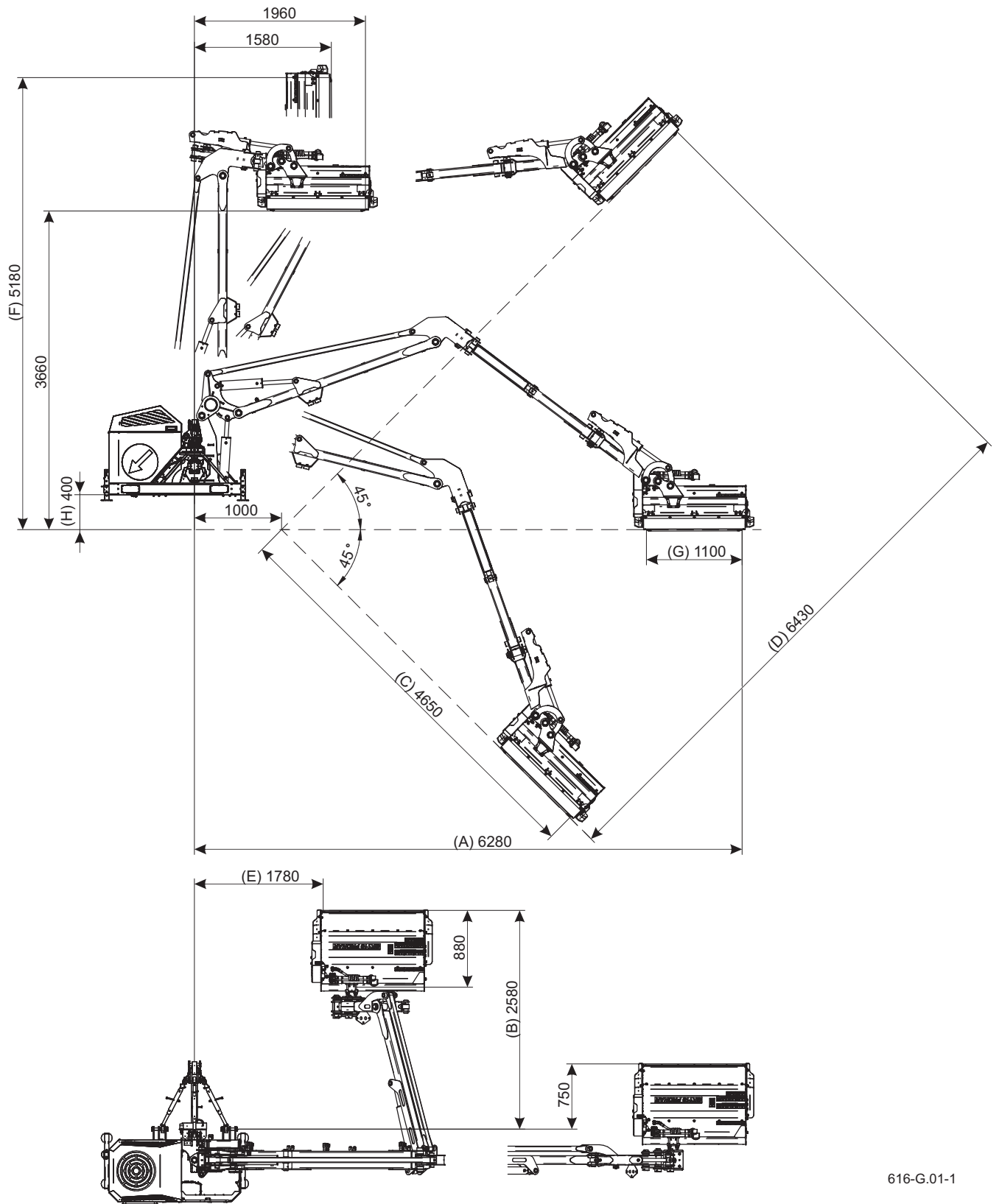

616-G.01-1

Figure 3.1 Working reach of the multifunction arm with GK110 head.

Table 3.2 Working reach of the multifunction arm - figure 3.1

	Unit	WWT604K/WWT608K
Horizontal reach (A)	m	6.28
Maximum forward reach (B)	m	2.58
Reach at 45° (C)	m	4.65
Reach on embankment at 45° (D)	m	6.43
Horizontal reach with the arm extended forward (E)	m	1.78
Vertical reach (F)	m	5.18
Width of GK110 head (G)	m	1.1
Height above ground (H)	m	0.4

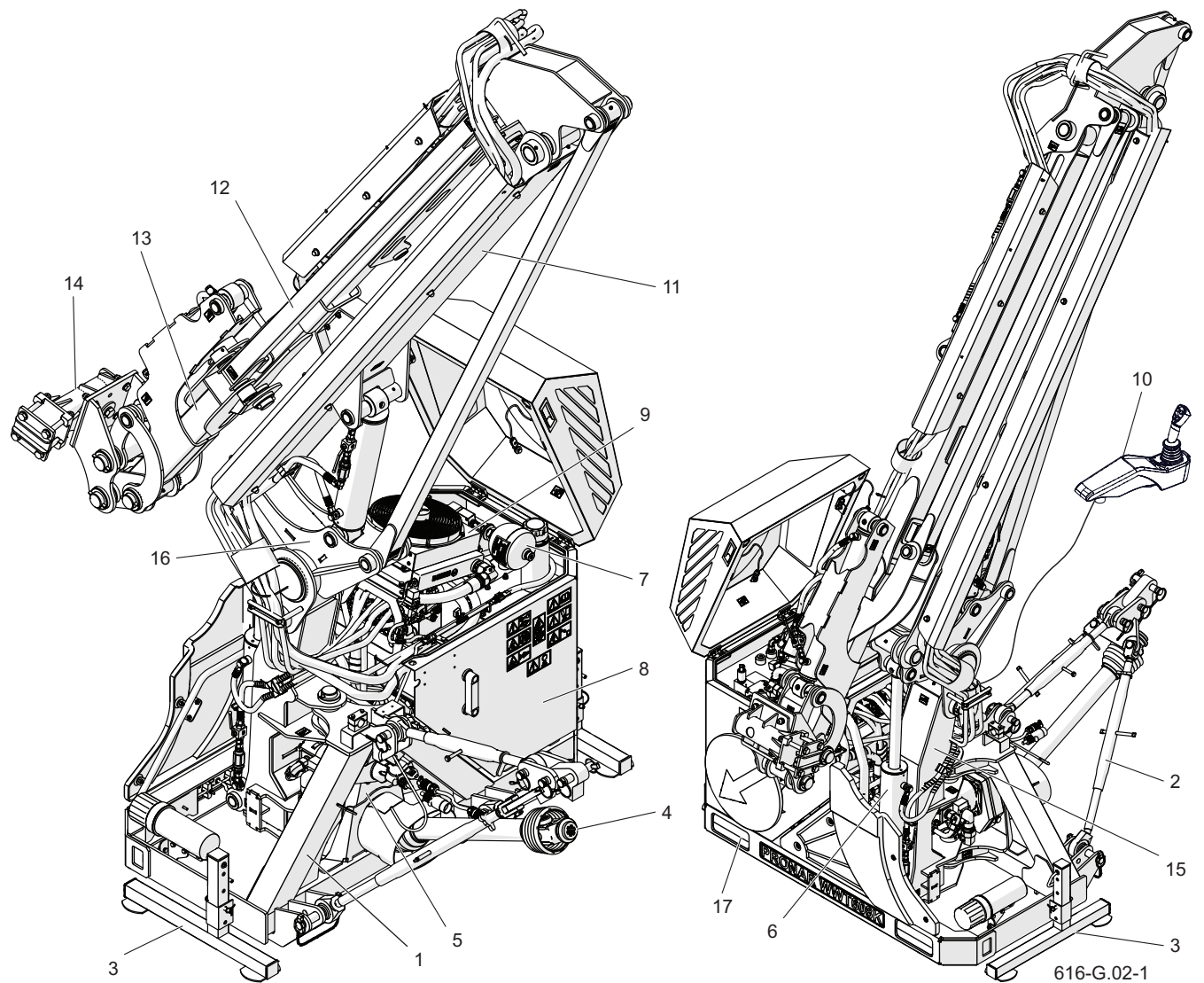

Figure 3.2 Multifunction arm design

- | | | |
|------------------------------------|------------------------------|----------------------|
| (1) frame | (2) three-point linkage lock | (3) support feet |
| (4) drive shaft | (5) drive system | (6) hydraulic system |
| (7) arm shock absorption unit | (8) oil tank | (9) oil cooler |
| (10) control panel with a joystick | (11) main arm | (12) tilting arm |
| (13) head arm | (14) working head connection | (15) rotary hanger |
| (16) rocker arm | (17) rear lights | |

G.2.5.616.01.1.EN

3.2 DESIGN AND OPERATION

Main components of the multifunction arm (FIGURE 3.2):

- frame (1) with three-point linkage lock (2),
- arm assembly, item (11, 12 and 13),
- drive system (5),
- hydraulic system (6),
- head connection (14).

The structure of the multifunction arm is built on the frame (1), to which the main arm (11), the tilting arm (12) and the head arm (13) are connected through the rotary hanger (15) and the rocker arm (16).

The rotary hanger (15) connected with rotation hydraulic cylinder (hydraulic safety device) protects the multifunction arm against damage when the working head hits an obstacle and makes it possible to set arms (11), (12), (13) in transport position. On the head arm (13) there is the TYPE 80 head connection (14) for attaching the working head. TYPE 60 connection is available as an option.

There are three attachment points on the frame (1) for connecting the multifunction arm with the rear linkage (three-point linkage) of the carrier vehicle (agricultural tractor). During work and transport, the three-point linkage of the carrier vehicle (agricultural tractor) is blocked with

the three-point linkage lock (2), which improves the stability of the carrier vehicle.

The multifunction arm is fitted with an independent hydraulic system (6) driven with the carrier vehicle's (agricultural trailer's) power take-off shaft (PTO). The drive shaft (4) supplies two circuits of the hydraulic system through the drive system (5). One circuit is for positioning the working head's arms while the other circuit is for driving the working head. Hydraulic pumps draw oil from independent oil tank (8) through suction filter and pump it into the two hydraulic circuits. Oil tank (8) is located on the frame on the opposite side of the main arm (11) mount. Thanks to this, the oil tank performs also the function of a counterweight and improves the stability of the carrier vehicle with the multifunction arm.

The hydraulic system is equipped with hydraulic oil cooler (9) installed on oil return to tank (8). The cooler fan is powered by the carrier vehicle's (tractor) electrical system through a wiring harness. The fan is switched on by the relay connected with the thermostat installed near the cooler when the allowed oil temperature in the cooler is exceeded. The cooler fan is switched on when oil temperature exceeds 52°C and switched off when oil is cooled

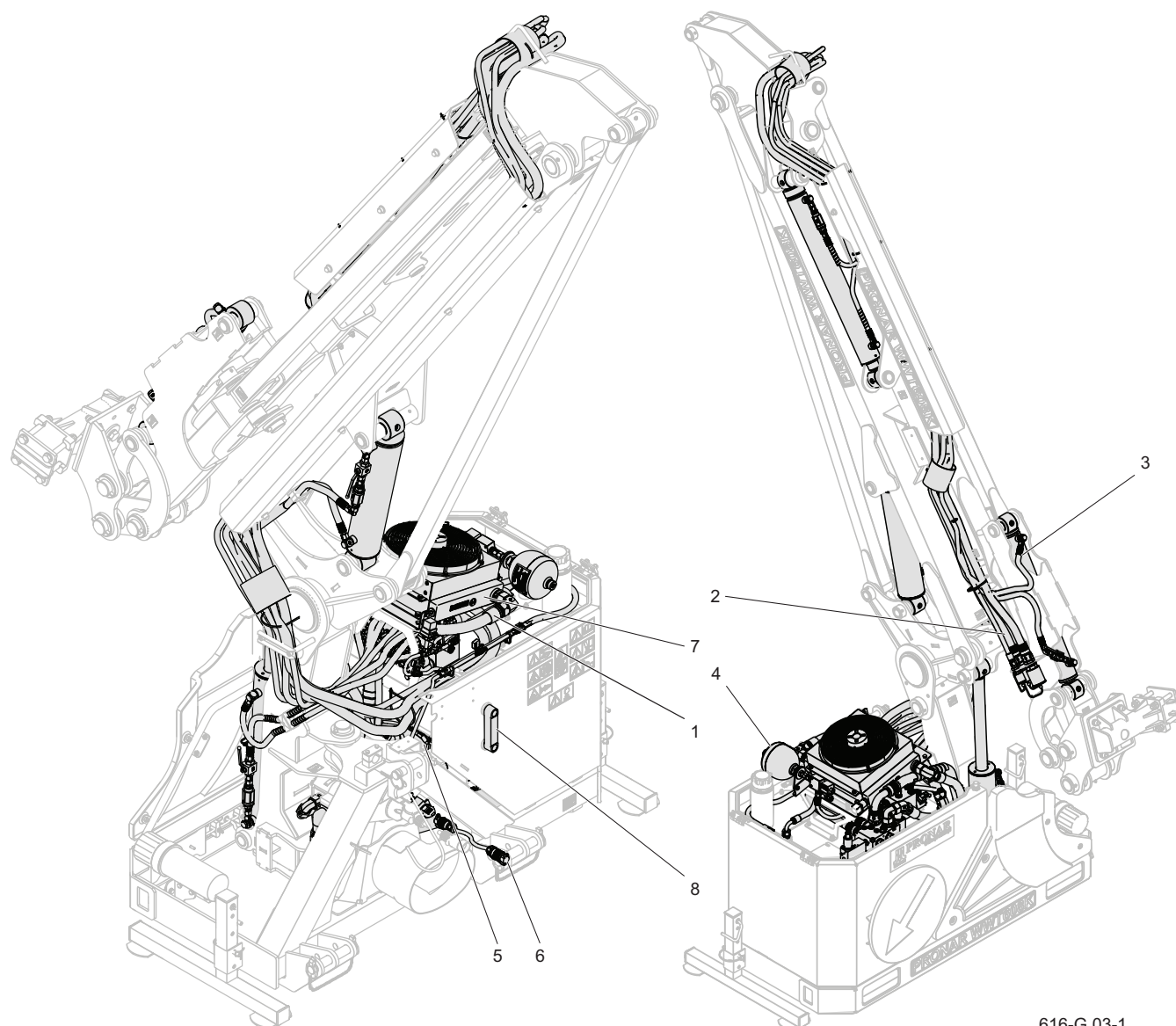

616-G.03-1

Figure 3.3 Hydraulic system design

- | | | |
|----------------------------------|--|-------------------------|
| (1) supply circuit | (2) head supply circuit | (3) arm drive circuit |
| (4) arm shock absorption | (5) hydraulic safety device shock absorption | |
| (6) cooler fan electrical system | (7) cooler plate | (8) oil level indicator |

down to a temperature below 42°C.

The main arm (11), the tilting arm (12) and the head arm (13) are tilted by means of hydraulic cylinders, which enable free manoeuvring of the multifunction arm. The hydraulic cylinders are controlled by means of electrohydraulic selective control valve

by the carrier vehicle's (tractor's) driver using control panel and joystick (10).

WWT604K and WWT608K multifunction arms differ in terms of electrohydraulic control. The WWT604K multifunction arm is controlled using the "on-off" method, which means that the arms are deflected

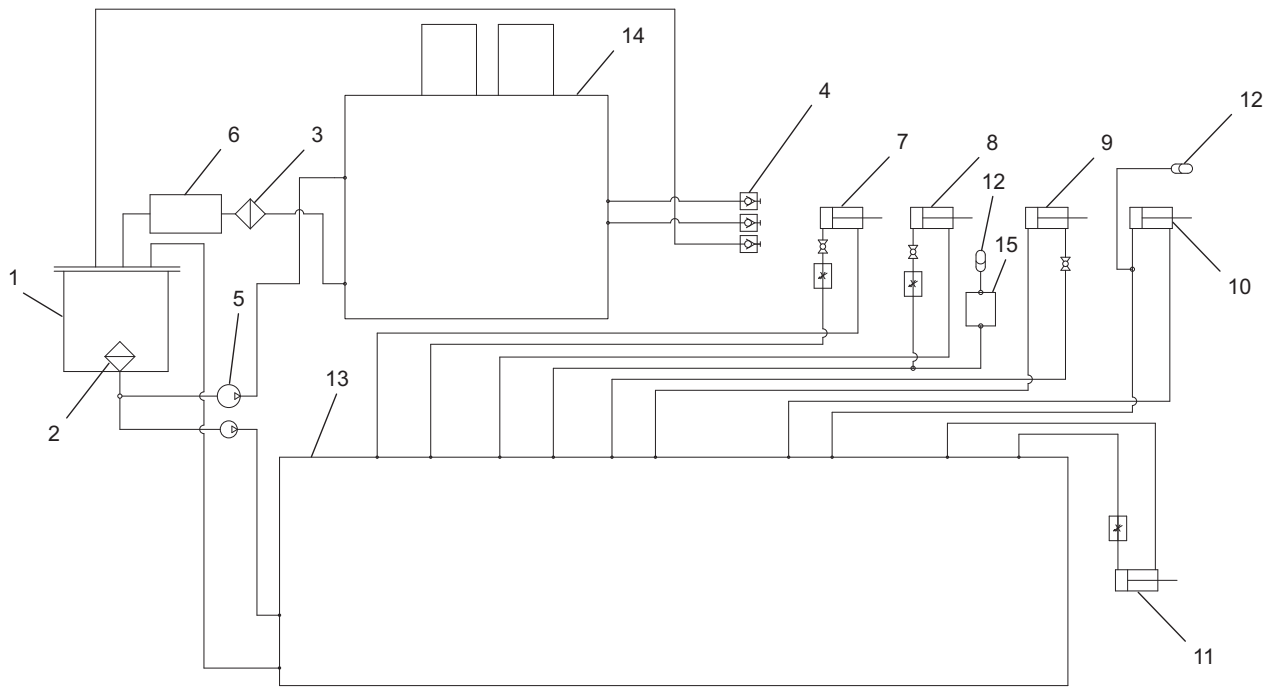

Figure 3.4 WWT604K multifunction arm's hydraulic system diagram

- (1) oil tank
 (2) coarse oil filter (suction filter) (3) fine oil filter
 (4) quick couplers (5) hydraulic pump (6) oil cooler
 (7) main arm hydraulic cylinder (8) rocker arm hydraulic cylinder (9) head rotation cylinder
 (10) hanger rotation cylinder (11) tilting arm hydraulic cylinder (12) hydraulic accumulator
 (13) hydraulic selective control valve for arm cylinders
 (14) hydraulic selective control valve for working head
 (15) hydraulic accumulator valve

at a constant speed regardless of the joystick (10) deflection angle. In the case of WWT608K multifunction arm, the arm

deflection speed is proportional to the joystick deflection angle.

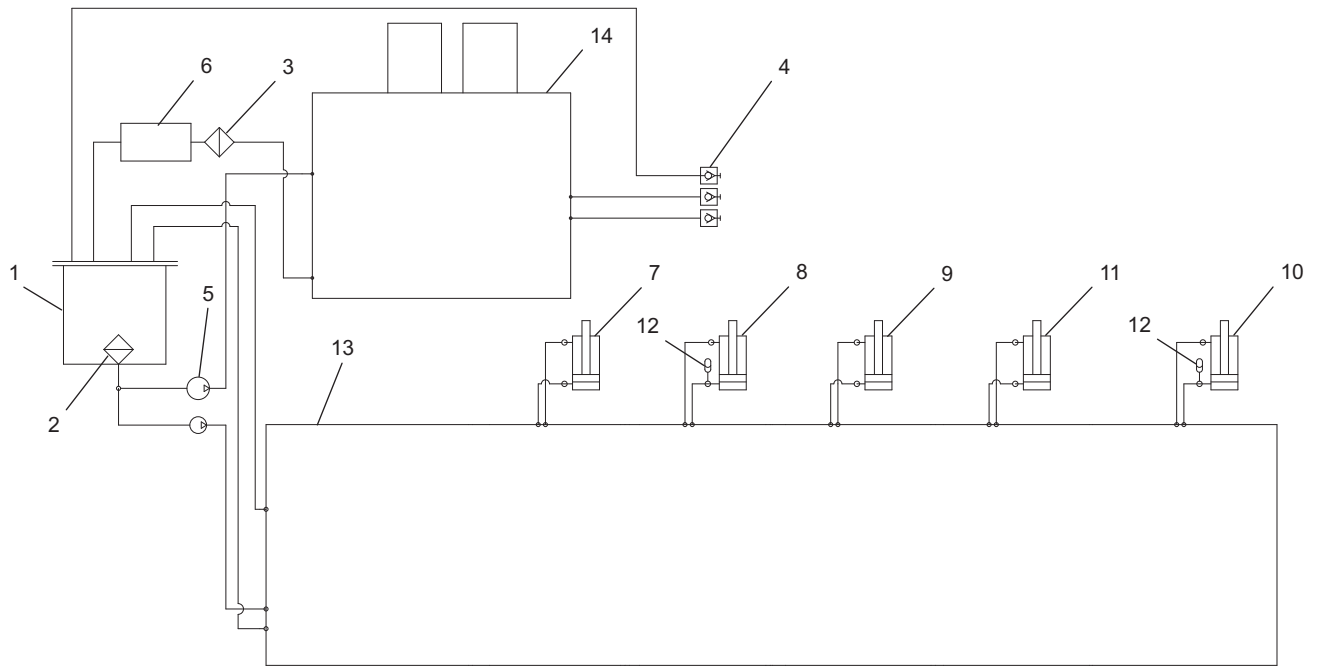

Figure 3.5 WWT608K multifunction arm's hydraulic system diagram

- | | | |
|--|--|----------------------------|
| (1) oil tank | (2) coarse oil filter (suction filter) | (3) fine oil filter |
| (4) quick couplers | (5) hydraulic pump | (6) oil cooler |
| (7) main arm hydraulic cylinder | (8) rocker arm hydraulic cylinder | (9) head rotation cylinder |
| (10) hanger rotation cylinder | (11) tilting arm hydraulic cylinder | (12) hydraulic accumulator |
| (13) hydraulic selective control valve for arm cylinders | | |
| (14) hydraulic selective control valve for working head | | |

G.2.5.616.02.1.EN

SECTION 4

CORRECT USE

4.1 PREPARE FOR WORK

The manufacturer guarantees that the machine is fully operational and has been checked according to quality control procedures and is ready for use. This does not release the user from an obligation to check the machine's condition after delivery and before first use. The machine is delivered to the user completely assembled.



IMPORTANT

Check technical condition of the multifunction arm before each use. In particular, check the technical condition of the suspension system, hydraulic system, drive system and the integrity of safety guards.

Before hitching to the carrier vehicle (agricultural tractor), the machine operator must check the technical condition of the multifunction arm and prepare it for test start-up. In order to do this:

- the user must carefully read this Operator Manual and observe all recommendations, understand the design and the principle of machine operation,
- check the condition of protective paint coat,
- inspect machine's individual components for mechanical damage

resulting from incorrect transport (dents, piercing, bent or broken components),

- check all lubrication points, lubricate the machine according to recommendations provided in section 5 "*Maintenance*",
- check technical condition of the hydraulic system;
- check if working head, linkage and safety guards are correctly installed,
- check technical condition of hitching system pins and locking cotter pins,
- check the hydraulic oil level in the hydraulic tank and multiplier gear box.

If all the above checks have been performed and there is no doubt as to the machine's good technical condition, it can be hitched to the carrier vehicle (tractor). Start the carrier vehicle's (agricultural tractor's)



IMPORTANT

Before beginning work lubricate all lubrication points.

engine, check all systems and perform a test run before beginning work. In order to inspect:

- hitch the multifunction arm to the carrier vehicle (tractor) (see "*Hitching*")

the multifunction arm to the carrier vehicle (tractor)”),

- start PTO drive,
- set the multifunction arm in working position (start unfolding the machine from the main arm hydraulic cylinder).

Engage multifunction arm's drive for 3 minutes and check the following:

- that there is no knocking or noise in the hydraulic pump drive system arising from scraping or grinding of metal elements,
- confirm that there are no oil leaks in the hydraulic system.

The multifunction arm's operation at no load should be smooth. Shaking of drive transmission is not acceptable, nor is abnormal noise and vibrations coming from loose nut and bolt connections. Check the



DANGER

Before using the multifunction arm, the user must carefully read this Operator Manual. Careless and incorrect use and operation of the multifunction arm, and failure to follow instructions in this Operator Manual is dangerous to your health. The multifunction arm must never be used by persons, who are not authorised to drive carrier vehicles (agricultural tractors), including children and people under the influence of alcohol or other drugs. Non-compliance with the safety rules of this Operator's Manual can be dangerous to the health and life of the operator and others. Before starting the multifunction arm, make sure that there are no bystanders in the danger zone.

hydraulic system for proper operation and oil leaks.

If any faults are detected they must be identified and rectified. If a fault cannot be rectified or the repair could void the warranty, please contact retailer for additional clarifications.



DANGER

Do NOT exceed the PTO rotation speed of 540 rpm. Otherwise the multiplier gear box and hydraulic system of the multifunction arm may be damaged.

H.2.5.28.01.1.EN

4.2 HITCHING THE MULTIFUNCTION ARM TO THE CARRIER VEHICLE (TRACTOR)

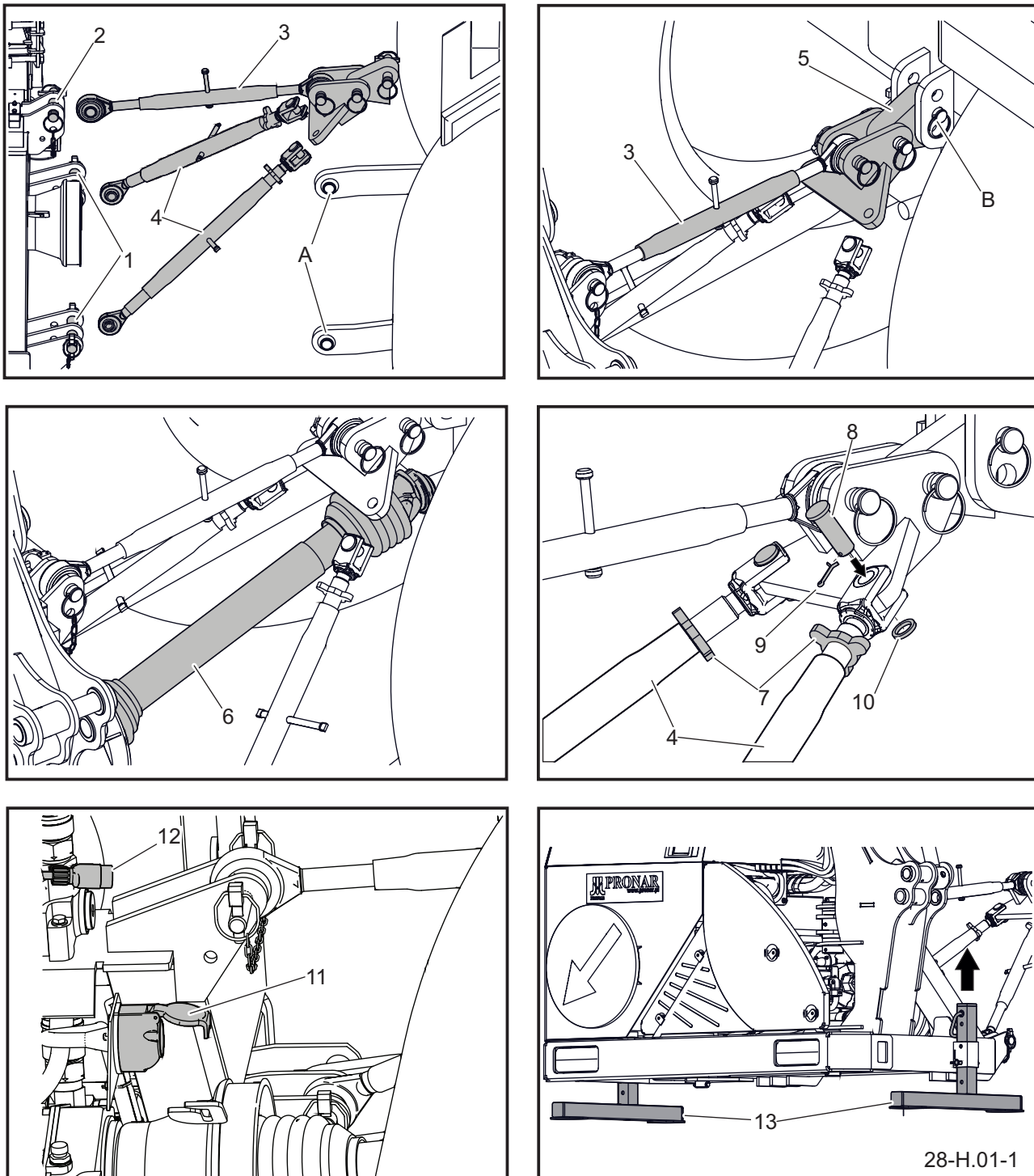

Figure 4.1 Hitching the multifunction arm to the carrier vehicle (tractor).

(A) lower links of the rear three-point linkage (B) upper securing point of the rear three-point linkage
 (1) lower fixing pins (2) upper fixing pin (3) central connector (4) lower links of the three-point linkage lock
 (5) three-point linkage lock bracket (6) drive shaft (7) locking nut (8) three-point linkage lock pin
 (9) cotter pin (10) washer (11) 7-pin electric socket (12) 3-pin electric socket (13) support feet
 (14) cotter pin (15) pin (16) cotter pin

**IMPORTANT**

Before hitching the multifunction arm to carrier vehicle, read the carrier vehicle (agricultural tractor) Operator Manual. Comply with the recommendations relating to linkage and mounting points.

**DANGER**

Do NOT operate the multifunction arm with the carrier vehicle (tractor) without the driver's cab. The carrier vehicle (tractor) should be equipped with the cab protecting the operator against possible hazards.

The operator should also use personal protective equipment such as protective clothing, safety goggles, safety helmet to reduce the risk of injuries.

**DANGER**

When hitching, there must be nobody between the machine and the carrier vehicle (agricultural tractor).

Exercise caution when hitching the machine.

The multifunction arm may be hitched to a carrier vehicle (tractor) which meets the requirements specified in Table 1.1 "Requirements for carrier vehicle (tractor)".

In order to hitch the multifunction arm to the carrier vehicle's (tractor's) rear three-point linkage, adhere to the following guidelines (FIGURE 4.1):

- reverse the carrier vehicle (tractor) and bring lower links (A) of the carrier vehicle's (tractor's) three-point linkage to lower pins (1) of the

**DANGER**

Do NOT operate the multifunction arm with a carrier vehicle (tractor) which has a complete vehicle kerb weight smaller than 5500 kg.

multifunction arm and set them at the same height with pins (1),

- turn off the carrier vehicle's (tractor's) engine and immobilize the carrier vehicle (tractor).
- connect lower links (A) of the carrier vehicle's (tractor's) three-point linkage. Connect lower links (4) of the three-point linkage lock system with pins (1) of the multifunction arm linkage. Secure pins (1) with cotter pins (14),
- connect central connector (3) of the three-point linkage lock with the upper fixing point (2) of the multifunction arm linkage, secure with pin (15),
- adjust the length of central connector (3) in order to connect the upper securing point of the three-point linkage (B) with bracket (5) of the three-point linkage lock system and secure with a cotter pin (16),
- connect the carrier vehicle's (tractor's) PTO to the multifunction arm's multiplier gear box by means of the drive shaft (6),
- when links (4) of the three-point

**TIP**

The proper alignment of the PTO shaft of the carrier vehicle (tractor) with the shaft of the sand spreader's drive system significantly extends the life of the drive shaft (1) (Figure 4.2).

linkage lock system are unlocked (FIGURE 4.1), raise the multifunction arm by means of lower links (2) (FIGURE 4.2) of the rear three-point linkage of the carrier vehicle (tractor) to such a height that drive shaft (1) connecting the multifunction arm's multiplier gear box with PTO shaft of the carrier vehicle (tractor) is positioned horizontally with regard to the ground.

Before connecting the multifunction arm to the carrier vehicle's (tractor) PTO shaft, the user must read the Operator Manual supplied by the PTO shaft's manufacturer and follow all instructions. Before connecting the drive shaft, the user shall check the technical condition of guards, the completeness and condition of securing chains and the overall technical condition of the shaft.

- both lower links (2) of the rear three-point linkage of the carrier vehicle (tractor) should, if possible, be positioned at the same height with regard to the ground.
- level the multifunction arm by

**DANGER**

Turn off the carrier vehicle's (tractor) engine and remove the key from the ignition before connecting the carrier vehicle's (tractor) rear PTO with the multifunction arm's multiplier gear box. Ensure that unauthorised persons do not have access to the carrier vehicle (agricultural tractor) cab. Before first use, adjust the length of PTO shaft according to Operator Manual of PTO shaft recommendations.

adjusting the length of central link (3).

- mount the three-point linkage by fixing the fork of links (4) (FIGURE 4.1) to the bracket of the three-point linkage lock using pins (8). Secure the pins with cotter pins (9).
- lock the set length of links (4) of the three-point linkage lock by means of lock nuts (7).
- connect 7-pole electric socket (11) of the power supply system of rear lamp assembly and 3-pole electric socket (12) of the power supply system of the multifunction arm's oil cooler fan and control panel with corresponding electric sockets on the carrier vehicle (tractor) (FIGURE 4.1).

A 3-pole electric socket installed at the rear of the carrier vehicle (tractor) is required to operate the multifunction arm. If the carrier vehicle is not equipped with such a socket or is equipped with a socket of a different type, install the power supply wiring harness on the carrier vehicle to make it

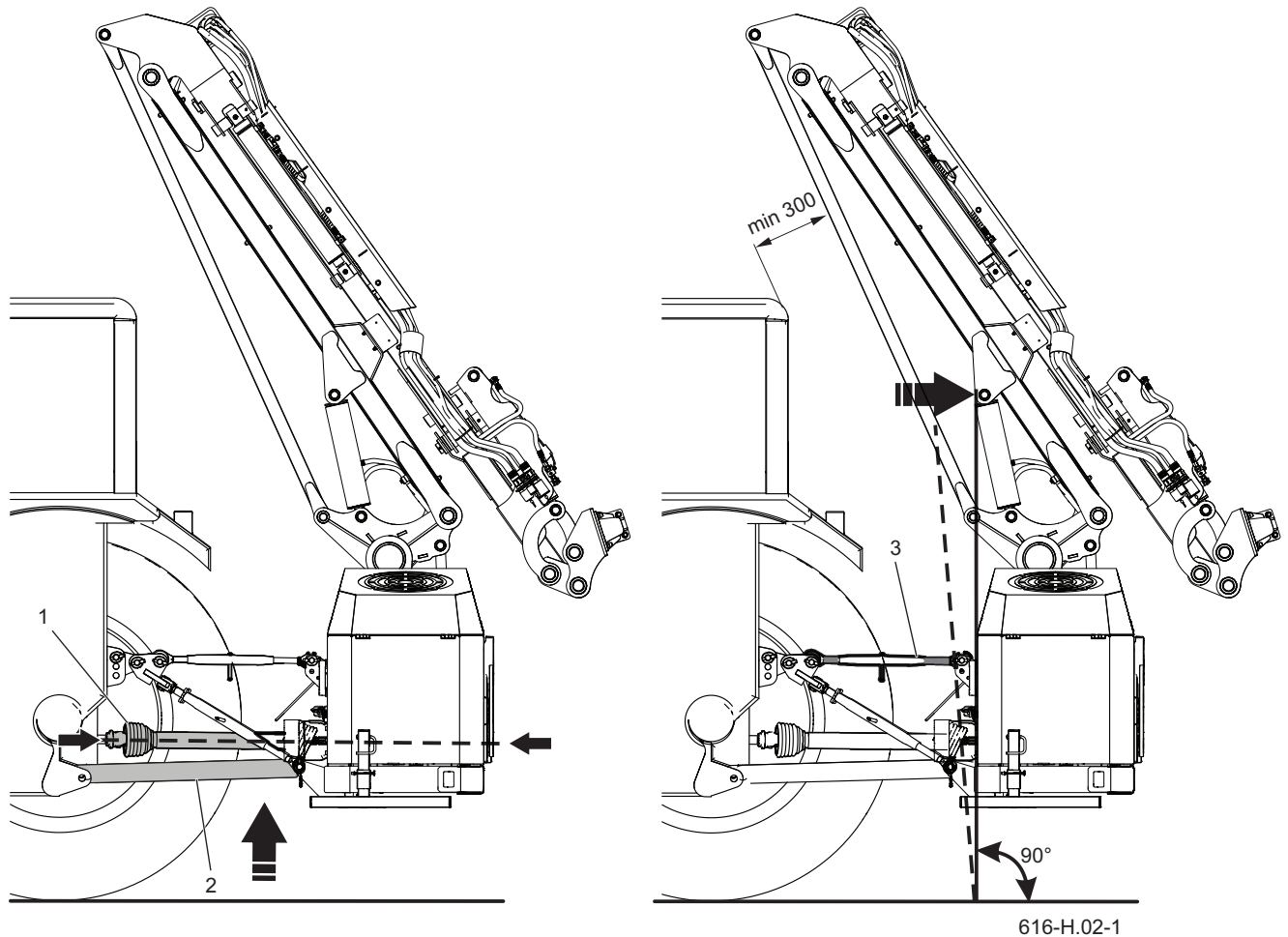

Figure 4.2 How to position the multifunction arm in relation to the ground.
 (1) drive shaft (2) lower links of the rear three-point linkage (3) central connector

possible to connect the multifunction arm's 3-pin electric socket.

- Mount the control panel and joystick (A) (FIGURE 4.3) of the multifunction arm inside the carrier vehicle's (tractor's) cab in the place which makes it possible to manoeuvre the controls freely from the seat of the carrier vehicle (tractor) operator. The control panel should be mounted in a stable manner, without weakening the protective structure of the carrier vehicle (tractor). Connect the plug of



IMPORTANT

Once the carrier vehicle (agricultural tractor) rear three-point linkage is locked with the three-point linkage lock, the user shall not use the control of the carrier vehicle (agricultural tractor) rear three-point linkage. Otherwise the carrier vehicle (agricultural tractor) rear three-point linkage and the three-point linkage lock may be damaged.

the control panel's wiring harness (A) (FIGURE 4.3) to the connection socket (4) of the multifunction arm's electrohydraulic system.

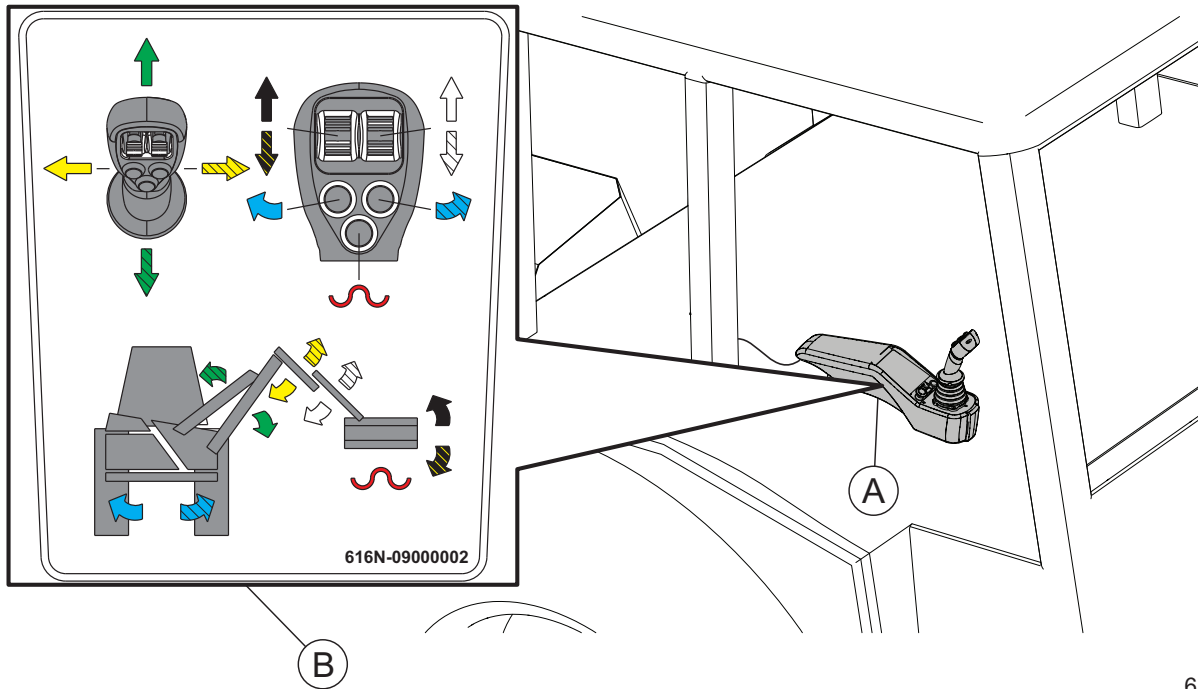

616-H.15-1

Figure 4.3 The multifunction arm controls in the carrier vehicle's (agricultural tractor's) cab plus a pictogram.

(A) control system

(B) control system pictogram



IMPORTANT

Misuse of carrier vehicle may cause damage to the vehicle as well as reduce stability, manoeuvrability and braking efficiency of the vehicle.

H.2.5.616.01.1.EN

4.3 BALLASTING THE CARRIER VEHICLE (TRACTOR)

Before hitching the machine to the carrier vehicle, confirm that the carrier vehicle is suitable for this purpose. Installation of implements on the rear three-point linkage must not result in exceeding the permissible total weight, permissible axle load and load capacity of carrier vehicle's tyres. The carrier vehicle's front axle must be always loaded with at least 20% of the carrier vehicle's weight.

Make the following calculations in order to confirm that these conditions are met:

Calculation of the minimum front ballast

$$G_{Vmin} = \frac{G_H \cdot (c+d) - T_V \cdot b + 0,2T_L \cdot b}{a + b}$$

Calculation of the minimum rear ballast

$$G_{Hmin} = \frac{G_V \cdot a - T_H \cdot b + 0,45T_L \cdot b}{b+c+d}$$

It is assumed that all parameters for the calculations of the minimum front and rear ballast are known.

If the parameters are unknown and cannot be determined, make the measurements using a weighing scale (FIGURE 4.4 – II). Measurement of permissible axle loads using a weighing scale.

- Measure the tare weight of the carrier

vehicle (T_L).

- Hitch the multifunction arm to the carrier vehicle and measure the front axle load (t_v). If the axle load is smaller than 20% of the carrier vehicle weight (T_L), add weights to exceed the minimum axle load value ($t_v \geq 20\%T_L$).
- Measure the total weight (t) of the carrier vehicle with the machine and weights. Check in the carrier vehicle's Operator Manual that the measured value is lower than the carrier vehicle's Permissible Tare Weight.
- Measure the rear axle load (t_H) and check in the carrier vehicle's Operator Manual if the measured value is smaller than the maximum permissible rear axle load of the carrier vehicle (t_{Hmax}).



IMPORTANT

The load on the front axle of the carrier vehicle (tractor) must be at least 20% of its own weight.

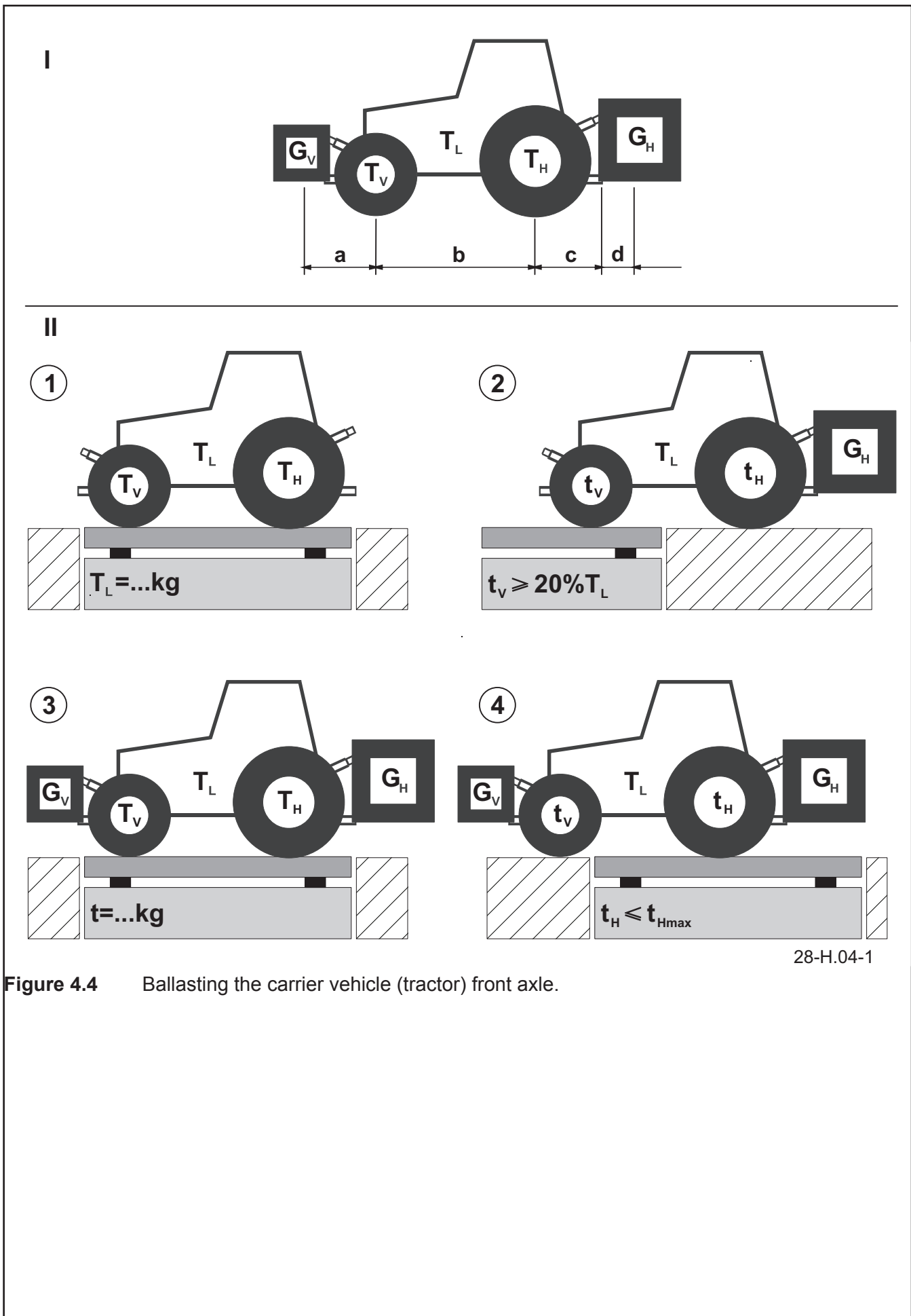

Figure 4.4 Ballasting the carrier vehicle (tractor) front axle.

Table 4.1 Ballasting the carrier vehicle (tractor)

Symbol / dimension (FIGURE 4.2)	Unit	Description
T_L	kg	Tractor tare weight
T_V	kg	Front axle load for tractor without machine
T_H	kg	Rear axle load for tractor without machine
t	kg	Load applied to axles of tractor with machine
t_V	kg	Front axle load for tractor with machine
t_H	kg	Rear axle load for tractor with machine
G_H	kg	Total weight of a rear-mounted machine
G_V	kg	Total weight of a front weight
a	m	Distance between the centre of gravity of the front weight and the front axle centre
b	m	Tractor axle base
c	m	Distance between the centre of the rear axle and the centre of the lower linkage arms of the tractor
d	m	Distance between the centre of the lower linkage arms of the tractor and the centre of gravity of the rear-mounted machine

H.2.5.616.02.1.EN

4.4 STARTING AND CONTROLLING THE MULTIFUNCTION ARM

Connect the multifunction arm to the carrier vehicle (tractor) and start the machine.

Engage rear PTO in the carrier vehicle (agricultural tractor) at a suitably low speed and then gradually increase the speed until PTO speed of 540 rpm is reached.

When the proper PTO speed is reached,

DANGER

The multifunction arm may only be started when all its protection guards are installed properly. Before engaging PTO drive make sure that there are no bystanders, especially children, near the multifunction arm.

IMPORTANT

Before operating the multifunction arm, lubricate all the lubrication points until the lubricant appears between the shaft and the bearing housing.

one may commence work with the multifunction arm.

Depending on the machine version, working conditions or parameters of the carrier vehicle (tractor), pay special attention to the sequence of folding and unfolding the individual arms (cylinders). The maximum extension of the arms, high weight of the working head or working on

DANGER

Do NOT exceed the PTO rotation speed of 540 rpm. Otherwise the multiplier gear box and hydraulic system of the multifunction arm may be damaged.

IMPORTANT

All the control panel operations should be performed only from the operator's seat in the carrier vehicle's (agricultural tractor's) cab. Operating the control panel outside the operator's cab is prohibited.

slopes may adversely affect the carrier vehicle stability, which can lead to very serious accidents.

Start unfolding the machine from the main arm hydraulic cylinder (joystick lever). Start folding the machine by folding the head arm - control roller (2) (FIGURE 4.5).

The arms of the multifunction arm and the working head are controlled by means of the control panel with joystick inside the

IMPORTANT

To control the multifunction arm movements, the operator must hold the joystick and press the safety button simultaneously (14) (FIGURE 4.5). This prevents accidental activation of the multifunction arm hydraulic cylinders when the joystick is unintentionally touched.

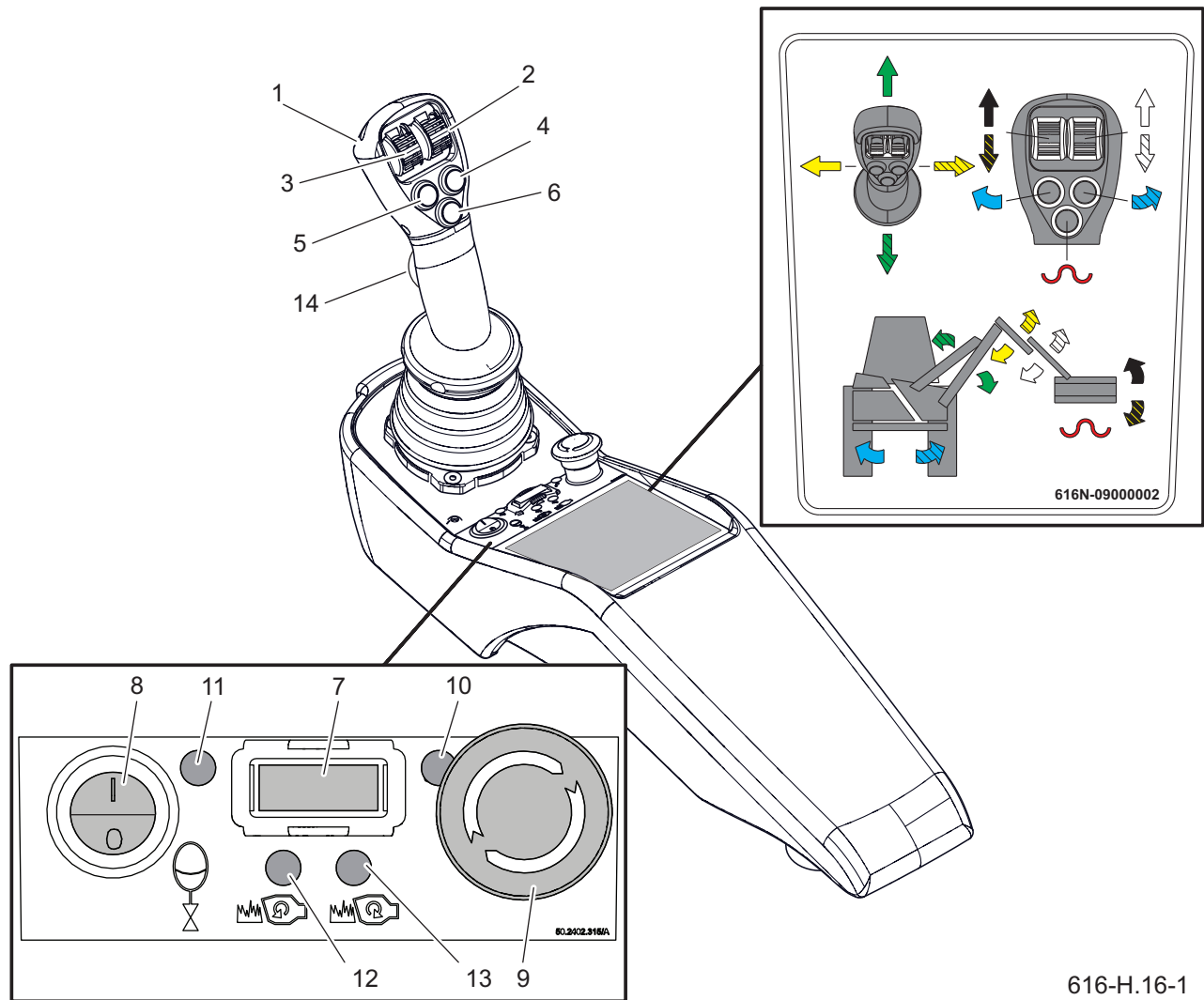

Figure 4.5 Operating the multifunction arm

(1) joystick lever (2) working head arm control roller (3) working head tilt control roller (4)(5) buttons for controlling the rotation of the arms around the hanger axis (6) button for activation of working head's floating function (7) switch for activating and changing the head rotation direction (8) switch for activating the arm shock absorbing unit (9) power supply switch (10) control panel power supply indicator light (11) indicator light of activation of the arm shock absorbing unit (12) indicator light of activation of the anti-clockwise rotation of the head drive (13) indicator light of activation of the clockwise rotation of the head drive (14) safety button

carrier vehicle (tractor) (FIGURE.4.3).

Before manoeuvring the multifunction arm, confirm that the power supply switch of the control panel (9) (FIGURE 4.5) is in the unlocked position. If the switch is depressed and locked, turn it to unlock. Activation of the power supply of the control panel is

signalled by the indicator light (10).

The hydraulic drive of the working head is switched on by depressing the right or left side of the button (7), depending on the selected rotation direction of the working head drive. The working head drive is OFF when the switch is set in its central

**DANGER**

Use caution and common sense when manoeuvring the multifunction arm, bearing in mind the wide range of the machine's arms.

When working with the multifunction arm, make sure that there are no bystanders, especially children, in the vicinity.

Carefully observe the position of the working head in relation to overhead power lines.

position. The selected rotation direction of the working head drive is indicated by the indicator lights (12) or (13).

When the arm shock absorbing function is required, turn on switch (8). When ground surface tracking is required for the working head, press button (6) of the working head's floating function.

When immediate emergency stopping of the multifunction arm is required, press the power supply switch of the control panel (mushroom button) (9). This button switches off the complete control system of the multifunction arm.

The multifunction arm movements are controlled by means of the joystick. The pictogram placed on the joystick lever mounting (1) (FIGURE 4.5) shows the

joystick control diagram.

Individual functions of the joystick (FIGURE 4.5):

- tilt joystick lever (1) forward or backward to actuate the hydraulic cylinder which tilts the main arm of the multifunction arm;
- tilt joystick lever (1) to the right or left to actuate the hydraulic cylinder which tilts the tilting arm of the multifunction arm;
- turn the right roller (2) to activate the hydraulic cylinder that tilts the working head arm.
- turn the left roller (3) to activate the hydraulic cylinder that tilts the working head.
- press the right (4) or left (5) function button on the joystick to actuate the hydraulic cylinder which rotates the arms of the multifunction arm around the hanger axis.
- When the button (6) is depressed, the head tilt floating position function is ON.

H.2.5.616.02.1.EN

4.5 ATTACHING THE WORKING HEAD

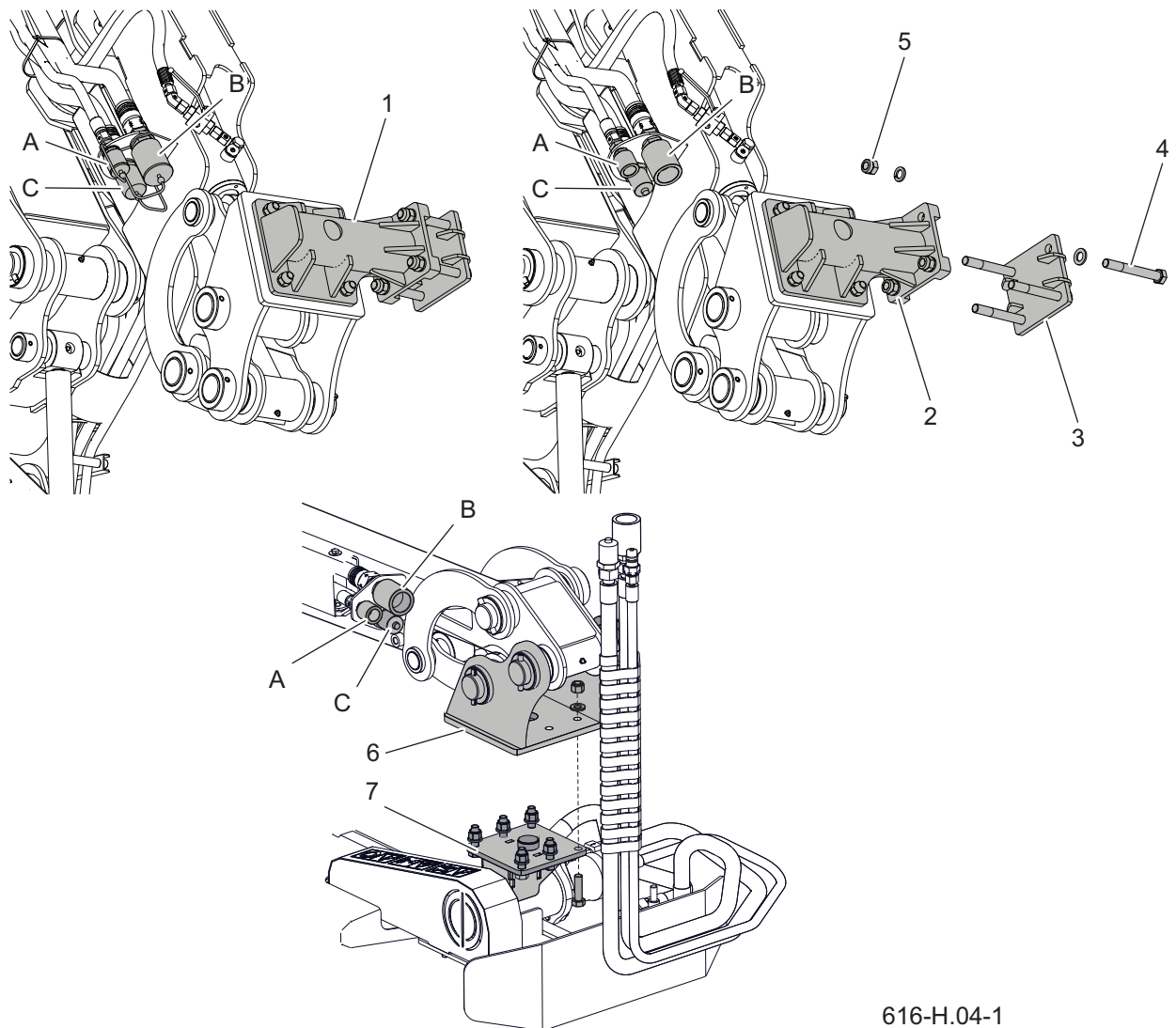

616-H.04-1

Figure 4.6 Attaching the working head to the multifunction arm.

- (1) working head attachment TYPE 80 (option: TYPE 60); (2) head attachment holder
 (3) head attachment lock (4) fixing bolts (5) nuts
 (6) connecting bracket (7) head connection plate
 (A) hydraulic return quick coupler (socket) (B) hydraulic supply quick coupler (socket)
 (C) hydraulic supply quick coupler (plug)



IMPORTANT

Before attaching the working head, the user must carefully read the Operator Manuals of the working head, carrier vehicle (agricultural tractor) and multifunction arm. Observe all instructions contained in the manuals.

The multifunction arm can be connected with working heads compatible with the working head connection and the hydraulic system of the multifunction arm.

In order to hitch the working head to the multifunction arm head (FIGURE 4.6),

**DANGER**

When hitching, there must be nobody between the machine and the carrier vehicle (agricultural tractor).

Exercise due caution when hitching the machine.

Before attaching the working head, turn off the carrier vehicle's (tractor's) engine and remove the key from the ignition. Ensure that unauthorised persons do not have access to the carrier vehicle (agricultural tractor) cab.

Check technical condition of the working head's guards and general technical condition of the machine.

**DANGER**

Prior to connecting individual hydraulic system lines, the user must carefully read the Operator Manual of the multifunction arm and working head and observe all recommendations of the Manufacturer.

When connecting the hydraulic quick couplers to the working head, make sure that the hydraulic system of the multifunction arm is not under pressure.

proceed as follows:

- reverse the carrier vehicle (tractor) and bring the multifunction arm's head attachment (1) close to the working head's attachment (support beam) or, depending on the head version, bring the connecting bracket (6) close to the attachment plate (7).
 - using the controls, position the multifunction arm's head attachment (1) at the same height as the working head's attachment (support beam). Manoeuvre the arms to bring the bracket (6) close to the plate (7).
 - turn off the carrier vehicle's (agricultural tractor) engine and prevent the carrier vehicle (tractor) from moving.
- connect the multifunction arm's head attachment (1) to the working head's attachment (support beam) by means of holder (2) and lock (3) of the attachment. Screw the entire assembly together with four fixing bolts (4). Bolt the multifunction arm's connecting bracket (6) to the attachment plate (7) of the working head.
 - connect the hydraulic quick couplers (A), (B) and (C) of the multifunction arm with the corresponding quick couplers of the working head's hydraulic lines.
 - turn on the carrier vehicle's (agricultural tractor) engine and the multifunction arm's drive. Raise the working head by means of the multifunction arm's controls.

H.2.5.39.03.1.EN

4.6 TRANSPORTING THE MACHINE

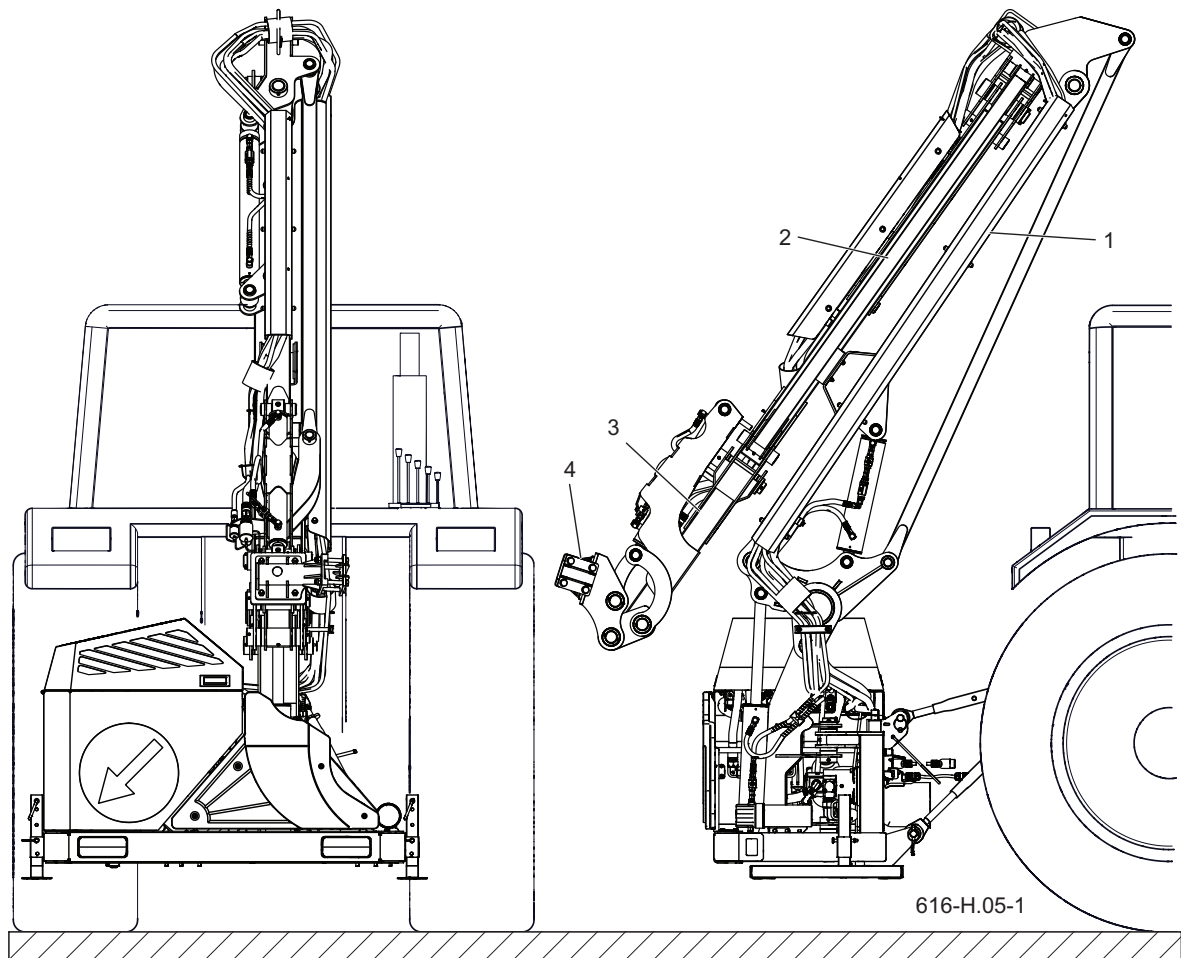

Figure 4.7 Transport position

(1) main arm

(2) tilting arm

(3) head arm

(4) working head connection



IMPORTANT

Before driving on public roads in order to transport the multifunction arm to the work site and back, the multifunction arm shall be folded to its transport position.

When driving on public roads, observe all road traffic regulations in force in the country, in which the machine is used.

Before driving onto a public road, check if all the lights and warning plates on the multifunction arm are properly mounted and visible.

The multifunction arm may not be used or transported in conditions of limited visibility.



DANGER

During transport, pay special attention and exercise particular caution when driving the carrier vehicle with the multifunction arm under viaducts, bridges and electric power lines.

The drive of the working head shall not be turned on when the multifunction arm is in its transport position.

For transport, set the multifunction arm in transport position (FIGURE 4.7) so that the multifunction arm width is minimal and the height measured from the road

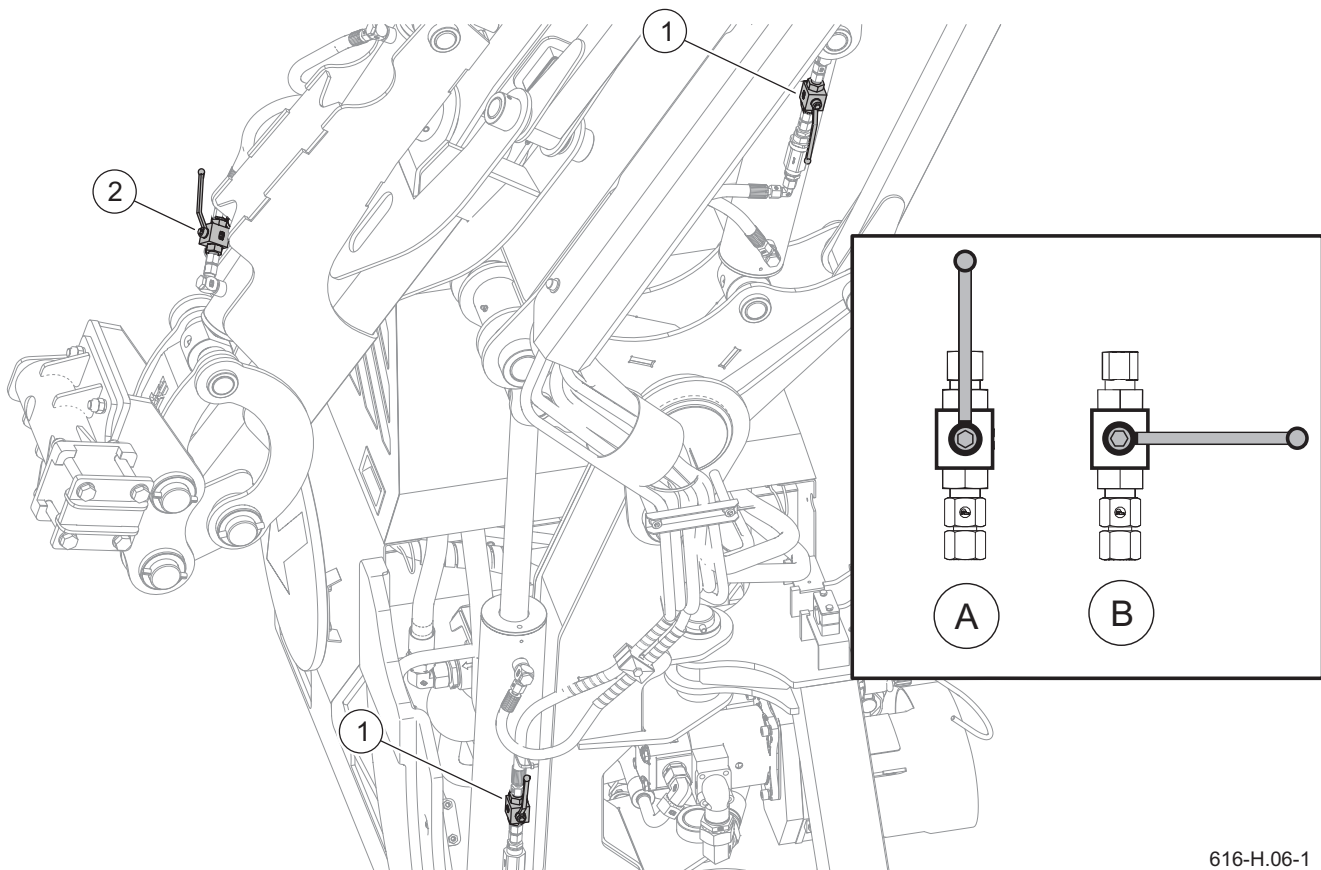

616-H.06-1

Figure 4.8 Ball valves of hydraulic system
 (1) arm tilt valves, (2) head rotation valve, (A) OPEN valve, (B) CLOSED valve

i TIP

When unfolding the multifunction arm from the transport position to the working position, start with the main arm cylinder.
 When folding the multifunction arm to the transport position, start with the head arm cylinder.

traffic regulations.

After setting the multifunction arm in transport position, switch the ball valves (1) and (2) protecting the cylinders to CLOSED position (B) (FIGURE 4.8), and set the switch (8) (FIGURE 4.5) of the arm shock absorbing unit to OFF position.

surface does not exceed the permissible height (4 metres) stipulated by the road

H.2.5.616.04.1.EN

4.7 SETTING THE MULTIFUNCTION ARM IN WORKING POSITION AND OPERATION

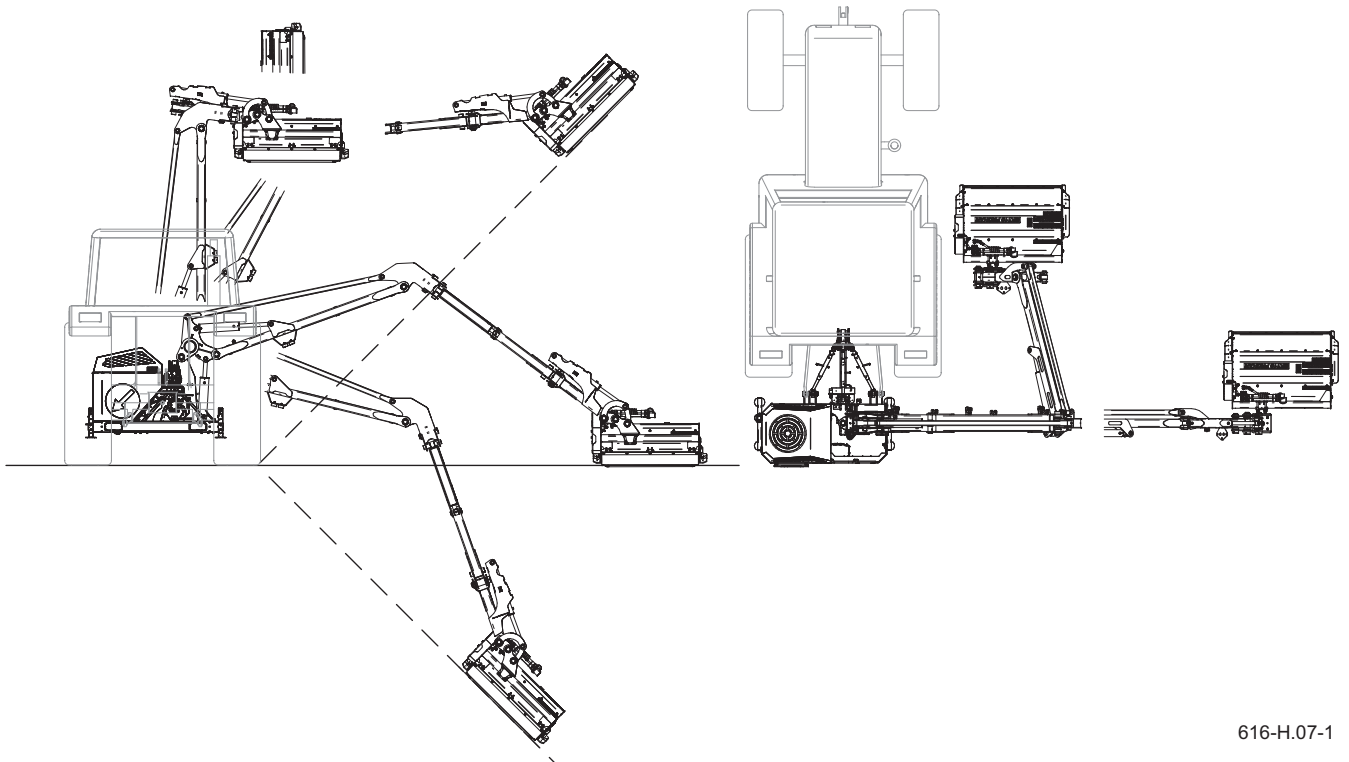

616-H.07-1

Figure 4.9 Examples of working positions of the multifunction arm with GK110 cutting head.

To set the multifunction arms in working position:

- switch the ball valves (1) of cylinders to the OPEN position (A) (FIGURE 4.8);
- turn on the drive of the carrier vehicle's (agricultural tractor) rear PTO;
- operate appropriate hydraulic cylinders of the multifunction arm (FIGURE 4.5) in order to place the working head in the working area (FIGURE 4.9),
- turn on the hydraulic motor which drives the working head using the

DANGER

The working head may only be started when all the protection guards of the multifunction arm and working head mounted properly and the working head is in its working position.

Bystanders should be at a safe distance from the multifunction arm's working head during work because of the risk of injury caused by thrown objects (stones, branches etc.).

multifunction arm's controls (FIGURE 4.5),

- engage appropriate carrier vehicle (agricultural tractor) gear and start working.

During operation, the multifunction arm

! DANGER

NEVER work if the rotating elements of the working head are directed towards the carrier vehicle (agricultural tractor). Otherwise the carrier vehicle (agricultural tractor) may be damaged or the operator may be injured.

During operation with the arm of the multifunction arm raised, keep the arms and working head at a safe distance from overhead power lines (FIGURE 4.11).

operator must ensure proper visibility of the machine and work area so that the operator can see obstacles and possible dangers in the route of the working head. The rotating elements of the working head shall never be directed towards the carrier vehicle (agricultural tractor) (FIGURE 4.10).

In line with regulations in force, it is not acceptable to place work stations, machines or devices directly below overhead power lines or at a distance, calculated horizontally from extreme lines, lower than (FIGURE 4.11):

- 3 m - for lines with rated voltage up to 1 kV,
- 5 m - for lines with rated voltage above 1 kV and up to 15 kV,
- 10 m - for lines with rated voltage above 15 kV and up to 30 kV,
- 15 m - for lines with rated voltage above 30 kV and up to 110 kV,

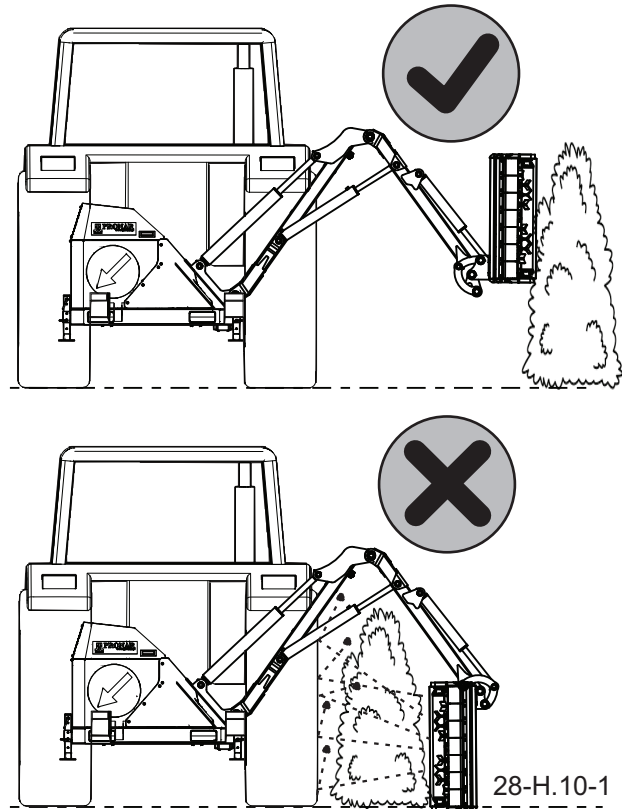

Figure 4.10 Safe position of the working head during hedge trimming.

- 30 m - for lines with rated voltage above 110 kV.

If it is impossible to keep the minimum distances in order to work safely in the vicinity of power lines, then apply to the nearest Power Utility and have the lines deenergised for the duration of operation.

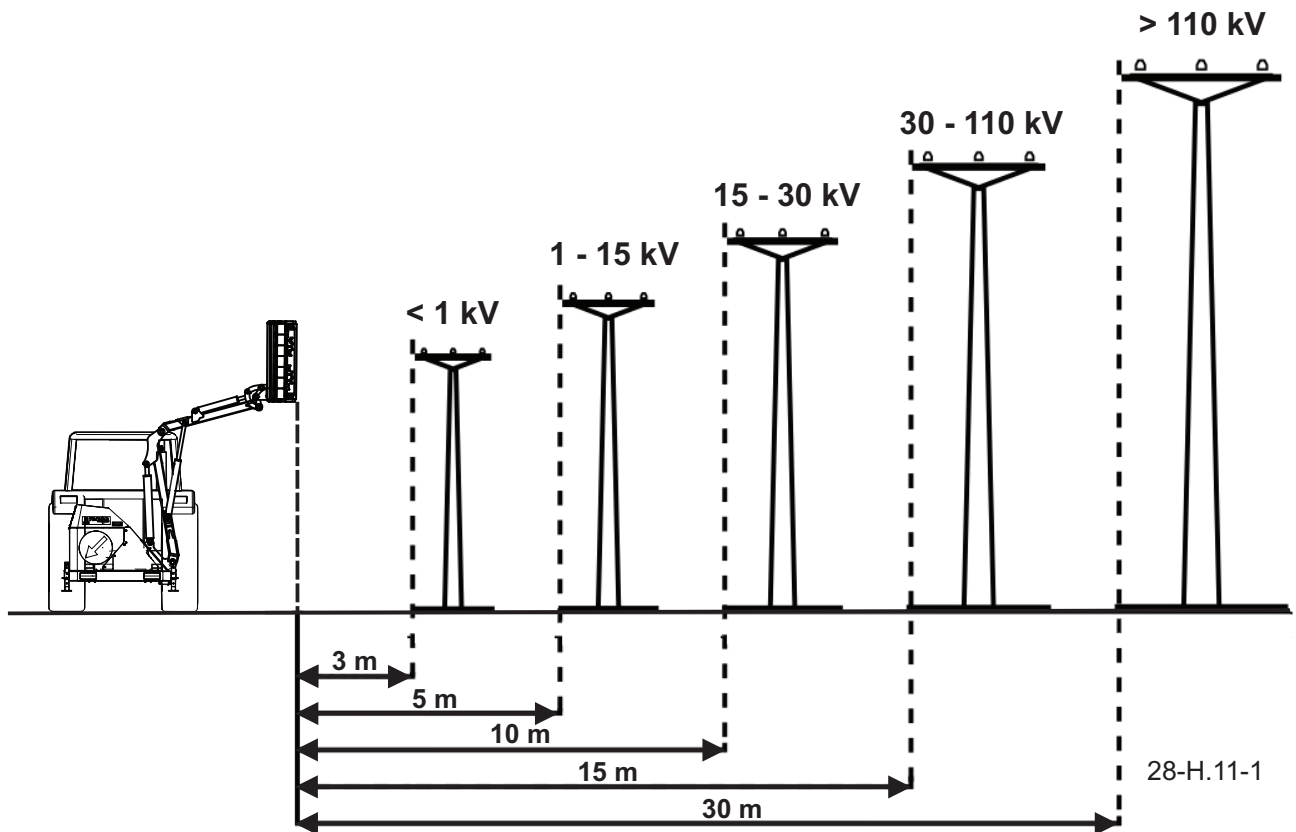

Figure 4.11 Safe distances of the machine from power lines.



NOTE

Operation and transport of the carrier vehicle (agricultural tractor) with hitched multifunction arm is allowed only on slopes with the maximum inclination of 7° . However, due to changing location of centre of gravity depending on type of working head, type of carrier vehicle (agricultural tractor) and length of multifunction arm, the allowable slope inclination angle may be smaller. That is why the user must exercise due caution and determine the maximum slope inclination angle for operating the carrier vehicle (agricultural tractor) with the multifunction arm. If the full reach of the multifunction arm is to be used, make sure that stability of the carrier vehicle (agricultural tractor) will be maintained. While working on slopes, do not raise the working head more than 0,5 m above the ground. In the event of a tilt of the carrier vehicle (agricultural tractor) with the multifunction arm, immediately lower the working head to the ground and stop the carrier vehicle (agricultural tractor).

When the working head moves along an uneven ground and requires frequent changes of its tilting position, switch on the floating position function by means of button (6) (FIGURE 4.5). At the time, the head changes its tilting position smoothly and adjusts its setting to the ground irregularity (D) (FIGURE 4.13).

When the working head is operated at the ground level and requires the function of tracking the ground surface along which it moves in the vertical plane, enable the arm shock absorbing function using switch (8) (FIGURE 4.5). At the time, the arm of the multifunction arm changes its vertical position smoothly and adjusts the head's

setting to the ground irregularities (B) (FIGURE 4.12).

When the working head is being operated with the arm of the multifunction arm raised, disable the working head's tilt floating position using button (6) (FIGURE 4.5) and the arm shock absorbing function using switch (8) (FIGURE 4.5).

When the multifunction arm with working head is raised, always start operating the working head at the highest point and move the head gradually downward. When the operation of the working head involves the falling of diverse plant material (branches) from a height, secure the work site so that no one is present in the zone of operation of the head and of the falling plant material.

While operating the multifunction arm, pay attention to uneven surface and obstacles on the route of moving multifunction arm. When an obstacle is encountered, the rotary hanger will rotate on the main frame (1) (FIGURE 3.2). In such a case, stop the carrier vehicle as quickly as possible, raise the working head and bypass the obstacle.

When driving across the road, pavement or other obstacles and when making turns, raise the working head and disengage the working head drive.

Be especially careful when mowing along

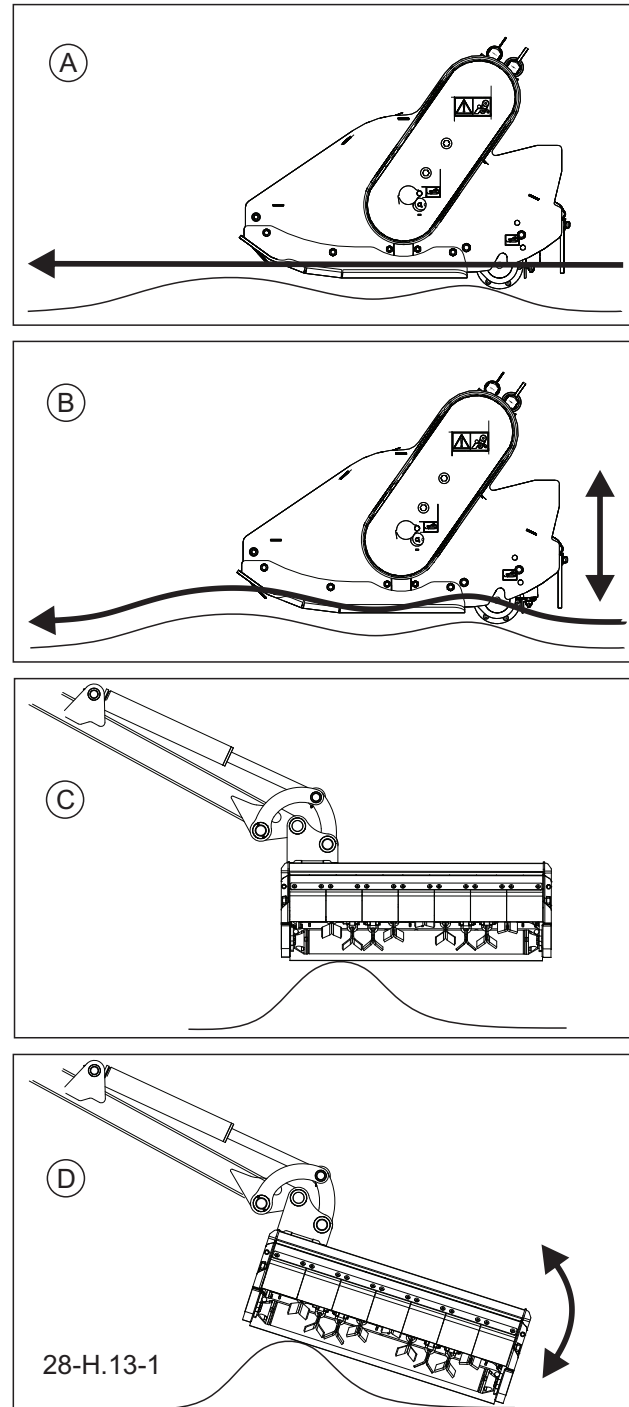

Figure 4.12 Arm shock absorbing function and head tilt floating position function.

(A)- operation of the head without the arm shock absorbing function; (B)- operation of the head with the arm shock absorbing function; (C)- operation of the head without the floating position function; (D)- operation of the head with the floating position function

**DANGER**

Bystanders should be at a safe distance from the multifunction arm's working head during operation with the arm raised because of the risk of diverse material (stones, branches etc.) falling and being thrown by the head.

ditches, furrows and slopes. If overheating of the multifunction arm hydraulic system occurs during operation of the working head, disengage the PTO drive and find the cause of overload.

While operating the multifunction arm, adjust the carrier vehicle's (agricultural tractor) speed. The speed depends on a number of factors. The main ones are:

- the working head type used
- the type of the material along which the working head moves
- the type and configuration of the ground along which the carrier vehicle travels
- weather conditions.

In all those cases, use the lowest possible speed of the carrier vehicle (agricultural tractor) at constant revolutions of the engine so that the carrier vehicle's PTO revolutions were fixed and equal to 540

rpm.

Hydraulic system supplying arm tilt hydraulic cylinders is equipped with throttle-check valves for adjusting oil flow speed (FIGURE 4.13). Consequently, working speed of arm tilt cylinders can be adapted to individual needs of multifunction arm operator.

The valve is regulated by turning it.

Turn the valve to the right, in the direction of oil flow, in order to reduce the flow speed. Reduction of oil flow speed slows down the cylinder motion and improves smoothness of its operation.

Turn the valve to the left, in the direction of oil flow, in order to increase the flow speed. Increase of oil flow speed accelerates the cylinder motion and reduces smoothness of its operation.

**NOISE WARNING**

Depending on the working conditions, the carrier vehicle (agricultural tractor) with the machine may generate noise exceeding the level of 85dB at the driver position. In such conditions, the operator should use personal protective equipment (ear protectors).

In order to reduce the level of noise during work, the operator cab windows and door should be closed.

H.2.5.616.06.1.EN

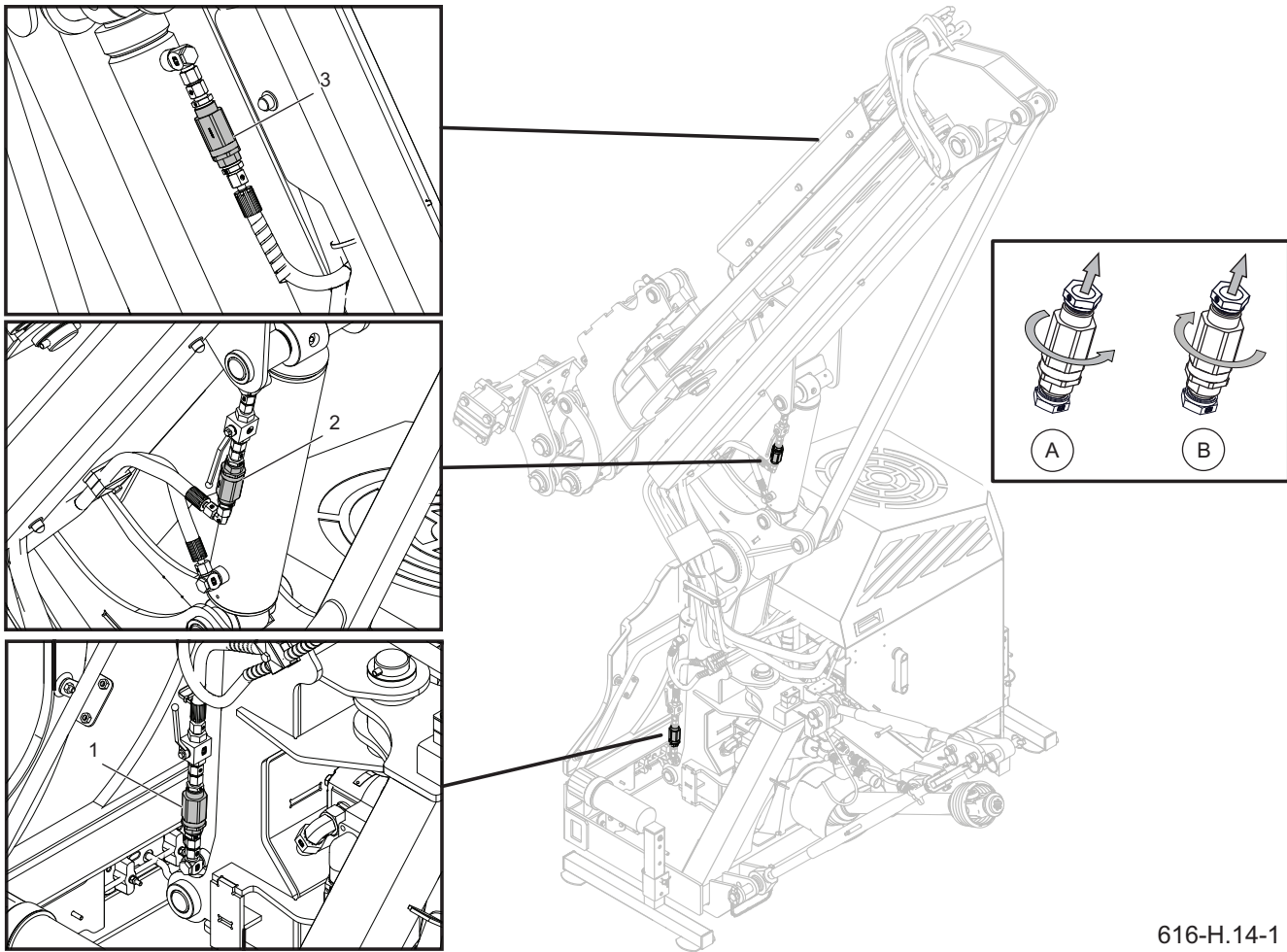

616-H.14-1

Figure 4.13 Throttle-check valves of arm tilt cylinders.

(1)- throttle-check valve of arm rocker tilt; (2)- throttle-check valve of main arm tilt, (3)- throttle-check valve of tilting arm tilt, (A)- reduction of oil flow speed; (B)- increase in oil flow speed.

SECTION 5

MAINTENANCE

5.1 TECHNICAL INSPECTION

When preparing the multifunction arm for use, check individual elements according to guidelines presented in Table 5.1.



NOTE

Do NOT use out of order multifunction arm.

Table 5.1 Technical inspection schedule

Description	Maintenance activities	Frequency
Correct mounting of the multifunction arm on the carrier vehicle's (tractor`s) linkage	Check if correctly installed	Daily before beginning work
Technical condition of the multifunction arm's hydraulic system	Check according to section „5.2 HYDRAULIC SYSTEM MAINTENANCE”	
The oil level in the hydraulic oil tank and multiplier gear box	Check according to section „5.2 HYDRAULIC SYSTEM MAINTENANCE”	
Check if all main nut and bolt connections are properly tightened	Tightening torque should be according to Table 5.3.	
Lubrication	Lubricate elements according to section „5.4 LUBRICATION”.	
Replace oil filter	According to section "5.2.1 OIL TANK AND OIL FILTERS"	Oil filter: After the first 100 h, then every 500 h or once a year Oil suction filter: Every 1000 h or once a year
Change oil in tank	According to section "5.2.1 OIL TANK AND OIL FILTERS"	Every 1000 h or once a year
Change oil in multiplier gear box	According to section "5.2.2 MULTIPLIER GEAR BOX WITH HYDRAULIC OIL PUMP ASSEMBLY"	After the first 50 hours, then every 1000 hours or every 6 months

I.2.5.28.01.1.EN

5.2 HYDRAULIC SYSTEM MAINTENANCE

Make sure that the oil in the multifunction arm hydraulic system is of adequate grade. Do not add hydraulic oil of other grade. The hydraulic system in a new multifunction arm is filled with HL46 hydraulic oil.

The hydraulic system must be tight. Inspect the seals when hydraulic cylinders are completely extended. If oil is found



NOTE

The condition of hydraulic system should be inspected regularly while using the machine. Flexible hydraulic lines should not be entwined or fractured.

on hydraulic cylinder body, check origin of leak. Minimum leaks are permissible with symptoms of "sweating", however in the event of noticing leaks in the form of "droplets" stop using the machine until faults are remedied.

If an oil leak is found on hydraulic connections, tighten the connections. If this does not remedy the problem, replace the lines and connection components. Always exchange each mechanically damaged component. Also, pay attention to ensure that flexible hydraulic lines are not fractured or entwined.

Because of its composition, the oil is not classified as a dangerous substance, however long-term action on the skin or eyes may cause irritation. In the event of contact of oil with skin wash the place of contact with water and soap. Do NOT apply organic solvents (petrol, kerosene). Contaminated clothing should be changed to prevent access of oil to skin. In the event of contact of oil with eye, rinse with large



DANGER

Before commencing whatever work on hydraulic system reduce the pressure in the system. During work on hydraulic system, use the appropriate personal protection equipment i.e. protective clothing, footwear, gloves and eye protection. Avoid contact of skin with oil.



NOTE

Flexible hydraulic lines should be replaced every 4 years of the machine operation.

quantity of water and in the event of the occurrence of irritation consult a doctor. Hydraulic oil in normal conditions is not harmful to the respiratory tract. A hazard only occurs when oil is strongly atomised (oil vapour), or in the case of fire during which toxic compounds may be released.

Table 5.2 HL46 Hydraulic oil specification

Item	Name	Value
1	ISO 3448VG viscosity classification	46
2	Kinematic viscosity at 40°C	41.4 ÷ 50.6 mm ² /s
3	ISO 6743/99 quality classification	HL
4	DIN 51502 quality classification	HL
5	Flash-point	above 220 °C

Oil fires should be quenched with carbon dioxide (CO₂), foam or extinguisher steam.

Do NOT use water for fire extinguishing.

Spilt oil should be immediately collected and placed in a marked tight container.

Used oil should be taken to the appropriate facility dealing with recycling or re-generation of oils.

OIL TANK AND OIL FILTERS

The oil tank (1) (FIGURE 5.1) holds 180 l of hydraulic oil type HL46. Check tank welded joints and connections of hydraulic conduits with tank every day.

Change the oil in the tank after every 1000 hours of operation of the multifunction arm or

once a year, whichever occurs first. In order to change oil in the tank, unscrew filler plug (2) and suck off oil from the tank through the inlet opening. Drain oil remaining on the tank bottom to previously prepared container by unscrewing the drain plug (4). Hydraulic oil can be drained through the drain plug

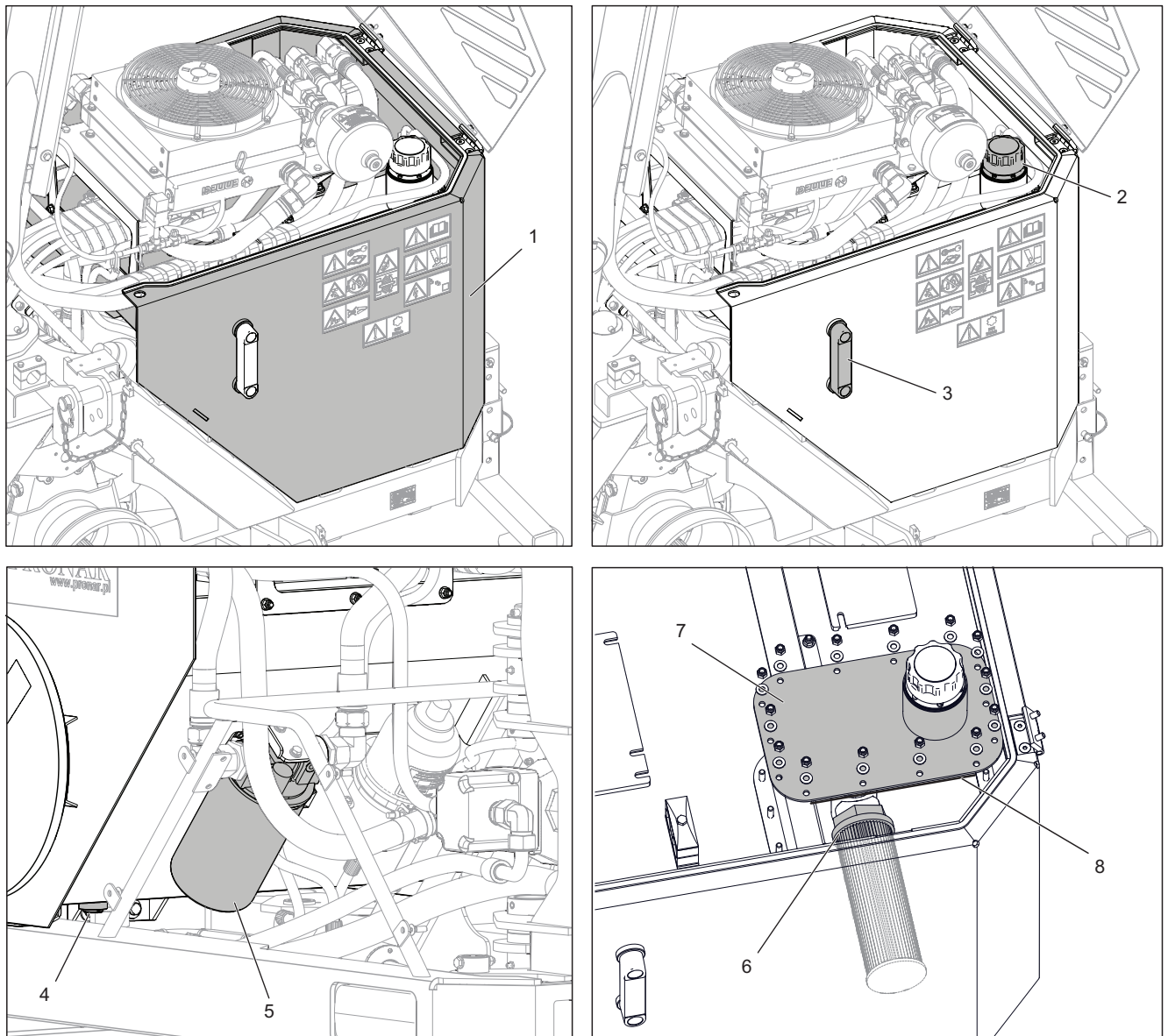

28-I.01-1

Figure 5.1 Oil tank

(1) oil tank

(2) oil filler plug

(3) oil level indicator

(4) drain plug

(5) oil filter

(6) oil suction filter (inside the oil tank)

(7) tank inlet cover

(8) seal

(4). For this purpose, prepare a sufficiently large container, taking into account the large amount of oil (180l) in the oil tank. Pour fresh oil into the tank through a strainer in the top inlet opening (2) of the tank having previously screwed the drain plug (4) in.

Before pouring oil in, change the suction filter (6) inside the oil tank.

Replace the suction filter (6) (inside the oil tank) every 1000 hours of operation of the multifunction arm or once a year while changing oil in the tank, whichever occurs first. To this end, unscrew the tank inlet cover (7) and through the opening in the tank unscrew the oil suction filter (6). If necessary, replace the cover seal (8).

The oil filter (5) is located on the oil return to the tank. Replace the filter for the first time after 100 hours of operation of the multifunction arm. Then replace the filter every 500 hours of operation of the multifunction arm or once a year, whichever occurs first. Replace the oil filter (5) when changing oil in the tank. In order to change filter:

- unscrew the clogged filter housing;
- cover sealing ring of new filter with oil (a few drops);

**NOTE**

While changing oil replace the suction filter (6) inside the tank and the external suction filter (5) every time.

- screw in new filter until sealing ring and casing make contact and then screw in by hand making one more half turn (do not screw in too tightly).

Each time you change the oil and filters and during the daily checks of the multifunction

**NOTE**

When unscrewing used suction filter (6) or oil filter (5), do not use a hammer, chisel etc. as this may damage the filter body. Use filters recommended by the machine manufacturer .

Screw in the filter by hand, without use of any tools.

arm hydraulic system, check the oil level on the tank sight glass (3). Sight glass float indicator should be near the top. If the indicator shows an insufficient oil level, fill the tank with oil to the required level.

MULTIPLIER GEAR BOX WITH PUMP**ASSEMBLY**

No oil leaks from the multiplier gear box (A) and pumps (B) (FIGURE 5.2) are allowed. These can be stopped by tightening the mounting bolts or replacing the seals.

If needed, unscrew the oil filler cap (1) or air vent (4) and top up gear oil to the sight glass level (2). To change oil, unscrew the drain plug (3) and drain oil into a prepared container. Then pour oil into the multiplier gear box through filler plug (1) or air vent (4) to the sight glass level (2).

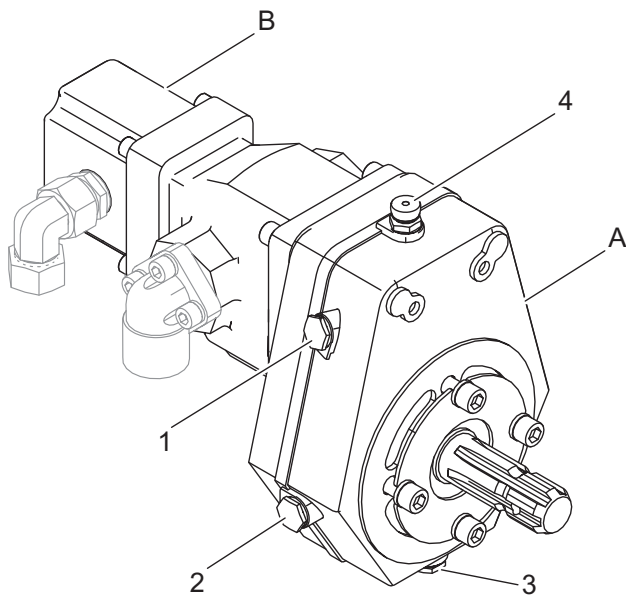

°C	ISO L-CKC	API GL-3/GL-5
	+45	320
+35	220	90
+25		
+15	150	85 W
+5	100	
-5		80 W
-15		

Figure 5.2 Multiplier gear box with a hydraulic pump and viscosity classification of gear oils depending on the ambient temperature.

(A)- multiplier gear box; (B)- hydraulic pumps assembly; (1)- oil filler plug; (2)- sight glass; (3)- drain plug; (4)- air vent.

NOTE

ISO L-CKC or API GL-3 / GL-5 quality class gear oil may be used. The viscosity class of the gear oil is selected depending on the ambient temperature (FIGURE 5.2).

The multiplier gear box is filled with gear oil of API GL-3 / GL-5 quality class and SAE 90 viscosity class as standard.

NOTE

Tighten the G3/8" plugs (drain plug, filler plug, sight glass and air vent of the multiplier gear box) with a torque of 30 Nm (+/- 2 Nm).

HYDRAULIC SELECTIVE CONTROL VALVES

NOTE

Each hydraulic selective control valve has overflow valves preset to the appropriate working pressure of the multifunction arm's hydraulic system. Do NOT adjust overflow valves because it may lead to damage to the multifunction arm's hydraulic system and working head. Adjustment of overflow valves should be carried out by an authorised service station of the machine manufacturer.

The electrohydraulic selective control valve (1) (FIGURE 5.3) is used for controlling five

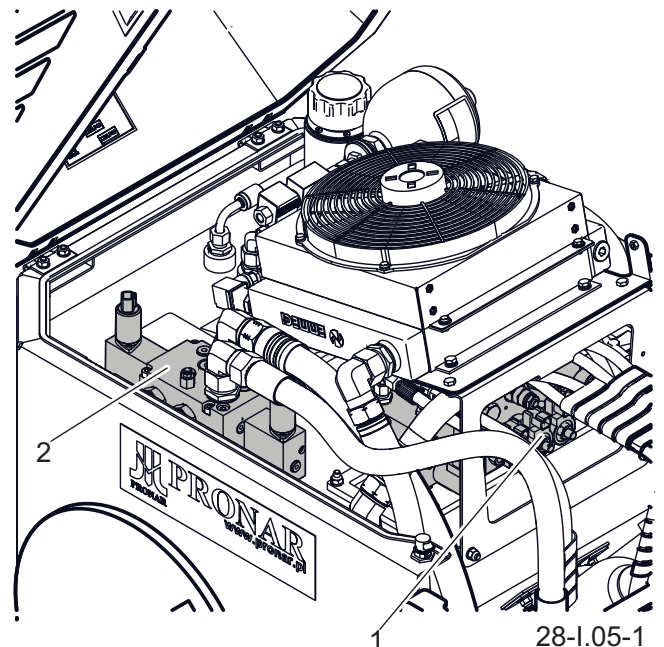

Figure 5.3 Electrohydraulic selective control valves

(1) electrohydraulic selective control valve of hydraulic cylinders of arms

(2) electrohydraulic selective control valve of working head

hydraulic cylinders of the support system. The electrohydraulic selective control valve (2) (FIGURE 5.3) starts the working head's hydraulic system. Selective control valves are controlled electrically by means of a control panel with a joystick from inside the tractor cab.

I.2.5.616.01.1.EN

5.3 ELECTRICAL SYSTEM MAINTENANCE

Maintenance of electrical system involves checking the operation of power supply system of oil cooler fan and lighting system. Check also the control panel with joystick for correct operation.

The multifunction arm's hydraulic system is equipped with a hydraulic oil cooler on which a fan supplied from the carrier vehicle's (tractor's) electrical system is installed. The fan is switched on by the relay connected with the thermostat installed near the cooler when the allowed oil temperature in the cooler is exceeded. The cooler fan is switched on when oil temperature exceeds 52°C and switched off when oil is cooled down to a temperature below 42°C.

Light-emitting diodes (LED) are used as



DANGER

Do not independently repair electrical system, except items described in section "ELECTRICAL SYSTEM MAINTENANCE". All electrical system repairs must be performed only by suitably qualified personnel.



IMPORTANT

Before beginning repairs of electrical system, disconnect the machine from power source. Do NOT travel with out of order lighting system. Burned-out or damaged lamps must be replaced with new ones.

the source of light in the multifunction arm's lamp assemblies. The lamps are maintenance-free because there is no need to change bulbs.

I.2.5.616.03.1.EN

5.4 LUBRICATION

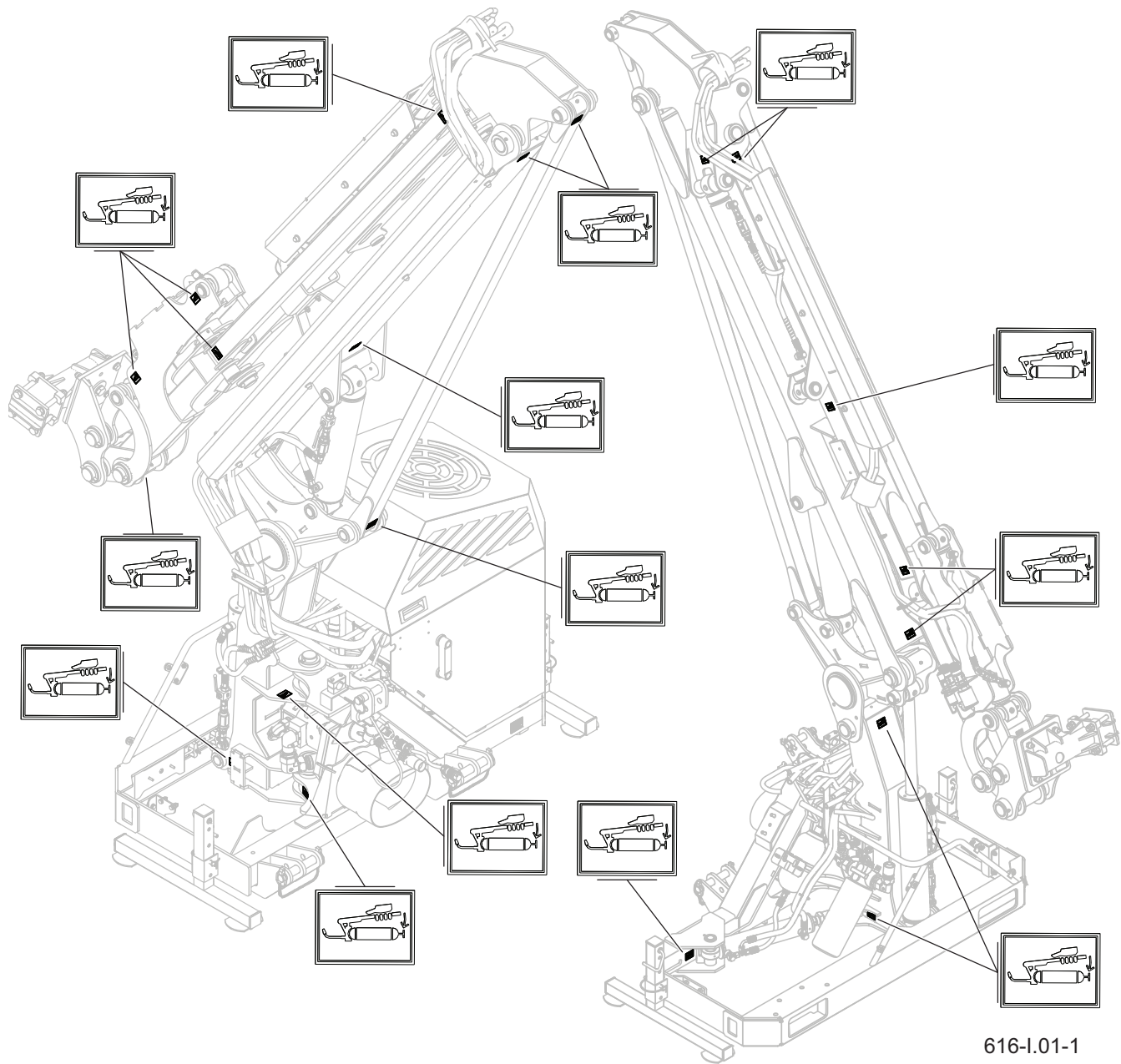

Figure 5.4 Location of lubrication point pictograms.

Grease all grease nipples located on the machine in places marked with the following pictogram (Figure 5.5):

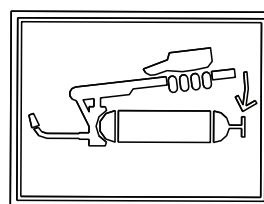

Figure 5.5 Lubrication symbol decal

Those are all the pins of articulated joints of the support system arms and the lugs of hydraulic cylinders.

Additionally, lubricate the drive shaft (option) in accordance with the drive shaft's Operator Manual provided by the drive shaft manufacturer.

Machine lubrication should be performed with the aid of a manually or foot operated grease gun, filled with generally available grease. Before commencing lubrication insofar as is possible remove old grease and

**IMPORTANT**

When using the machine the user is obliged to observe lubrication instructions according to attached schedule. Excess lubricant causes depositing of additional contaminants in places requiring lubrication, therefore it is essential to keep individual machine components clean.

other contamination. Remove and wipe off excess oil or grease

I.2.5.616.04.1.EN

5.5 TIGHTEN BOLT CONNECTIONS

Before each use of the machine and during maintenance and repair work, confirm that all bolt connections are properly tightened. If any clearances in bolt connections are found, tighten bolt connections using appropriate tightening torque (TABLE 5.3), unless other tightening parameters are

given. Recommended torque values apply to non-greased steel bolts.



NOTE

Should it be necessary to change individual parts, use only original parts or those indicated by the Manufacturer. Non-adherence to these requirements may put the user and other people's health and life at risk, and also cause damage to the machine.

Table 5.3 Tightening torque for nut and bolt connections

THREAD DIAMETER [mm]	5.8	8.8	10.9
	TIGHTENING TORQUE [Nm]		
M6	8	10	15
M8	18	25	36
M10	37	49	72
M12	64	85	125
M14	100	135	200
M16	160	210	310
M20	300	425	610
M24	530	730	1,050
M27	820	1,150	1,650
M30	1050	1,450	2,100
M32	1050	1,450	2,100

I.2.5.28.05.1.EN

5.6 STORAGE

After completed work, the multifunction arm should be carefully cleaned and washed with a water jet. While washing do not direct a strong water or steam jet at information and warning decals, bearings or hydraulic lines. Nozzle of pressure or steam washer should be kept at a distance of not less than 30 cm from cleaned surface.

After cleaning, inspect the whole machine, inspect technical condition of individual elements. Repair or replace any used or damaged components.

In the event of damage to the paint coat, clean rust and dust from damaged area, degrease and then paint with undercoat and after it is dry paint with surface coat paint retaining colour uniformity and even thickness of protective coating. Until the time of touch-up painting, the damaged place may be covered with a thin layer of grease or anticorrosion preparation. Multifunction arm should be kept in a closed or roofed building.

If the multifunction arm will not be used for a long period of time, protect it against adverse weather conditions. The multifunction arm should be lubricated according to the instructions provided regardless of the date of the last lubrication.

Protect against corrosion all cooperating elements i.e. pins, articulated joints, hydraulic cylinder rods. Cover them with a thin layer of grease.

The multifunction arm should be stored in a roofed building inaccessible for children and animals. The multifunction arm disconnected from the carrier vehicle (tractor) should be placed on support feet, on level, sufficiently hard surface in such a manner as to ensure that it is possible to connect it again. Set the arms of the multifunction arm in such a manner as to ensure that the working head installed on the arm rests on the ground. Dismount the control panel of the multifunction arm from the cab of the carrier vehicle (tractor) and protect it against adverse weather conditions.

5.7 TROUBLESHOOTING

Table 5.4 Troubleshooting

TYPE OF FAULT	CAUSE	REMEDY
It is impossible to control support system arms	Control panel is damaged	Repair at an authorised service point
	Multifunction arm's hydraulic system is out of order	Check individual elements of the multifunction arm's hydraulic system
	Selective control valve is damaged	Repair at an authorised service point
	The power supply switch of the control panel is depressed	Unlock the power supply switch of the control panel (turn it)
	Damaged control panel (joystick)	Repair at an authorised service point
	Fuse is blown	Replace the fuse on the power supply wiring harness of the fan
Overheating of the multiplier gear box	Wrong level of oil in the multiplier gear box casing	Check oil level.
	Damaged multiplier gear box bearings	Repair at an authorised service point
It is impossible to start the working head or the head is working too slowly	Control panel is damaged	Repair at an authorised service point
	Selective control valve is damaged	Repair at an authorised service point
	Hydraulic pump is damaged	Repair at an authorised service point
	Damaged PTO drive	Check PTO drive
	Damaged control panel (joystick)	Repair at an authorised service point
	Fuse is blown	Replace the fuse on the power supply wiring harness of the fan
Oil cooler fan does not turn on	Damaged thermostat	Replace the cooler thermostat with a new one
	Power supply failure of fan electrical system	Check power supply

I.2.5.616.07.1.EN

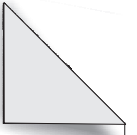

A series of horizontal lines for writing, spaced evenly down the page.