

# INTRODUCTION

Information contained herein is current at date of publication. As a result of improvements, some numerical values and illustrations contained in this publication may not correspond to the factual specification of the machine supplied to the user. The manufacturer reserves the right to introduce design changes in machines produced that facilitate operation and improve the quality of their work, without making minor amendments to this Operator's Manual.

This Operator's Manual is an integral part of the machine's documentation. Before using the machine, the user must carefully read this Operator's Manual and observe all recommendations.

This guarantees safe operation and ensures failure-free work of the machine. The machine is designed to meet obligatory standards, documents and legal regulations currently in force.

The manual describes the basic safety rules and operation of Pronar VMP-10S mixer feeder.

If the information contained in the Operator's Manual needs clarification then the user should refer for assistance to the sale point where the machine was purchased or to the Manufacturer.

## MANUFACTURER'S ADDRESS:

*PRONAR Sp. z o.o.  
ul. Mickiewicza 101A  
17-210 Narew*

## CONTACT TELEPHONES

*+48 085 681 63 29*

*+48 085 681 64 29*

*+48 085 681 63 81*

*+48 085 681 63 82*

## SYMBOLS APPEARING IN THIS OPERATOR'S MANUAL

Information, descriptions of danger and precautions and also recommendations and prohibitions associated with user safety instructions are marked:



and also preceded by the word "**DANGER**". Failure to observe the instructions may endanger the machine operator's or other person's health or life.

Particularly important information and instructions, the observance of which is essential, are distinguished in the text by the sign:



and also preceded by the word "**ATTENTION**". Failure to observe the instructions may lead to damage to the machine as a result of improper operation, adjustment or use.

In order to focus the user's attention on the need to perform maintenance, the relevant section of the Operator's Manual is marked with the pictogram:



Additional tips and advice for machine operation are marked with the sign:



and also preceded by the word "**TIP**".

## **DIRECTIONS USED IN THIS OPERATOR'S MANUAL**

Left side – side to the left hand of the operator facing in the direction of machine's forward travel.

Right side – side to the right hand of the operator facing in the direction of machine's forward travel.

## **REQUIRED MAINTENANCE ACTIVITIES**

Maintenance actions described in the manual are marked with the sign:

Result of maintenance/adjustment actions or comments concerning the performance of actions are marked with the sign:

**PRONAR Sp. z o.o.**

ul. Mickiewicza 101 A  
17-210 Narew, Polska

tel./fax: (+48 85) 681 63 29, 681 63 81, 681 63 82,  
681 63 84, 681 64 29

fax (+48 85) 681 63 83

http://www.pronar.pl

e-mail: pronar@pronar.pl

## Deklaracja zgodności WE maszyny

PRONAR Sp. z o.o. deklaruje z pełną odpowiedzialnością, że maszyna:

Opis i dane identyfikacyjne maszyny	
Ogólne określenie i funkcja:	<b>WÓZ PASZOWY</b>
Typ:	<b>T015</b>
Model:	-----
Numer seryjny:	
Nazwa handlowa:	<b>WÓZ PASZOWY PRONAR VMP-8 WÓZ PASZOWY PRONAR VMP-10 WÓZ PASZOWY PRONAR VMP-10S WÓZ PASZOWY PRONAR VMP-12</b>

do której odnosi się ta deklaracja, spełnia wszystkie odpowiednie przepisy dyrektywy **2006/42/WE** Parlamentu Europejskiego i Rady z dnia 17 maja 2006 r. w sprawie maszyn, zmieniającej dyrektywę 95/16/WE (Dz. Urz. UE L 157 z 09.06.2006, str. 24)

Osobą upoważnioną do udostępnienia dokumentacji technicznej jest Kierownik Wydziału Wdrożeń w PRONAR Sp. z o.o., 17-210 Narew, ul. Mickiewicza 101A.

Deklaracja ta odnosi się wyłącznie do maszyny w stanie, w jakim została wprowadzona do obrotu i nie obejmuje części składowych dodanych przez użytkownika końcowego lub przeprowadzonych przez niego późniejszych działań.

Narew, dnia 29.12.2009r.

Miejsce i data wystawienia

Z-CA DYREKTORA  
d/s technicznych  
członek zarządu

*Roman Omelaniuk*

Imię, nazwisko osoby upoważnionej  
stanowisko, podpis

# TABLE OF CONTENTS

<b>1 BASIC INFORMATION</b>	<b>1.1</b>
1.1 IDENTIFICATION	1.2
1.1.1 IDENTIFICATION OF MIXER FEEDER	1.2
1.1.2 AXLE IDENTIFICATION	1.3
1.1.3 LIST OF SERIAL NUMBERS	1.4
1.2 PROPER USE	1.5
1.3 EQUIPMENT	1.7
1.4 WARRANTY TERMS	1.9
1.5 TRANSPORT	1.10
1.5.1 TRANSPORT ON VEHICLE	1.10
1.5.2 INDEPENDENT TRANSPORT BY THE USER	1.13
1.6 ENVIRONMENTAL HAZARDS	1.13
1.7 WITHDRAWAL FROM USE	1.15
<b>2 SAFETY ADVICE</b>	<b>2.1</b>
2.1 BASIC SAFETY RULES	2.2
2.1.1 BASIC SAFETY RULES	2.2
2.1.2 HITCHING AND UNHITCHING FROM TRACTOR	2.3
2.1.3 LOADING THE MIXER FEEDER AND FEED MIXING	2.4
2.1.4 HYDRAULIC SYSTEM	2.4
2.1.5 OPERATING PTO SHAFT.	2.5
2.1.6 CLEANING, MAINTENANCE AND ADJUSTMENT	2.6
2.1.7 DRIVING ON PUBLIC ROADS	2.10
2.1.8 TYRES	2.12
2.1.9 DESCRIPTION OF RESIDUAL RISK	2.13
2.2 INFORMATION AND WARNING DECALS	2.14

<b>3 DESIGN AND OPERATION</b>	<b>3.1</b>
3.1 TECHNICAL SPECIFICATION	3.2
3.2 DESIGN OF MIXER FEEDER	3.3
3.2.1 CHASSIS	3.3
3.2.2 TANK	3.4
3.2.3 MAIN BRAKE	3.7
3.2.4 PARKING BRAKE	3.11
3.2.5 DRIVE TRANSMISSION SYSTEM – STANDARD VERSION	3.12
3.2.6 DRIVE TRANSMISSION SYSTEM – OPTIONAL VERSION	3.14
3.2.7 TRANSMISSION LUBRICATION SYSTEM	3.15
3.2.8 HYDRAULIC SYSTEM OF THE SLIDE GATES	3.16
3.2.9 ELECTRICAL SYSTEM	3.17
<b>4 CORRECT USE</b>	<b>4.1</b>
4.1 PREPARING THE MIXER FEEDER FOR WORK	4.2
4.1.1 PRELIMINARY INFORMATION	4.2
4.1.2 HAND-OVER AND INSPECTION OF THE MACHINE AFTER DELIVERY	4.2
4.1.3 PREPARING THE MIXER FEEDER FOR THE FIRST USE, TEST RUN OF THE MIXER FEEDER	4.3
4.1.4 PREPARING THE MIXER FEEDER FOR NORMAL USE	4.4
4.2 HITCHING AND UNHITCHING THE MIXER FEEDER	4.5
4.3 FILLING THE TANK AND FEED PREPARATION	4.10
4.4 ANALYSIS OF FEED MIXTURE	4.12
4.5 FEEDING	4.13
4.6 OPERATION OF THE TWO-SPEED TRANSMISSION	4.15
4.7 ADJUSTMENT OF COUNTER BLADES	4.16
4.8 CLEANING	4.18
4.9 PROPER USE AND MAINTENANCE OF TYRES	4.18

4.10 DRIVING ON PUBLIC ROADS	4.19
------------------------------	------

## **5 MAINTENANCE** **5.1**

5.1 PRELIMINARY INFORMATION	5.2
5.2 SERVICING WHEEL AXLE	5.2
5.2.1 PRELIMINARY INFORMATION	5.2
5.2.2 INITIAL INSPECTION OF AXLE BRAKES	5.3
5.2.3 CHECKING WHEEL AXLE BEARINGS FOR SLACKNESS	5.4
5.2.4 ADJUSTMENT OF AXLE BEARING SLACKNESS	5.6
5.2.5 MOUNTING AND DISMOUNTING WHEEL, INSPECTION OF WHEEL NUT TIGHTENING	5.7
5.2.6 CHECKING AIR PRESSURE IN TYRES, EVALUATING TECHNICAL CONDITION OF TYRES AND STEEL WHEELS	5.10
5.2.7 ADJUSTMENT OF MECHANICAL BRAKES	5.11
5.2.8 REPLACEMENT OF PARKING BRAKE CABLE AND ADJUSTMENT OF CABLE TENSION.	5.13
5.3 PNEUMATIC SYSTEM MAINTENANCE	5.16
5.3.1 PRELIMINARY INFORMATION	5.16
5.3.2 CHECKING AIR TIGHTNESS AND VISUAL INSPECTION OF PNEUMATIC SYSTEM	5.16
5.3.3 CLEANING THE AIR FILTERS	5.18
5.3.4 DRAINING WATER FROM AIR TANK	5.19
5.3.5 CLEANING THE DRAIN VALVE	5.21
5.3.6 CLEANING AND MAINTAINING PNEUMATIC CONDUIT CONNECTIONS	5.21
5.4 HYDRAULIC SYSTEM MAINTENANCE	5.22
5.4.1 PRELIMINARY INFORMATION	5.22
5.4.2 CHECKING HYDRAULIC SYSTEM TIGHTNESS	5.22
5.4.3 CHECKING TECHNICAL CONDITION OF HYDRAULIC COUPLERS AND SOCKETS.	5.23
5.4.4 REPLACEMENT OF HYDRAULIC CONDUITS	5.23

5.5	LUBRICATION OF MIXER FEEDER	5.24
5.6	CONSUMABLES	5.28
5.6.1	HYDRAULIC OIL	5.28
5.6.2	LUBRICANTS	5.29
5.7	REDUCTION GEAR MAINTENANCE	5.30
5.8	ADJUSTING DRAWBAR TO TRACTOR HITCH	5.32
5.9	DISASSEMBLY AND INSTALLATION OF CUTTING BLADES	5.35
5.10	ADJUSTING THE POSITION OF CUTTING BLADES	5.37
5.11	SHARPENING THE CUTTING BLADES	5.38
5.12	ENTERING THE TANK	5.40
5.13	CLEANING THE MIXER FEEDER	5.41
5.14	STORAGE	5.42
5.15	TIGHTENING TORQUE FOR NUT AND BOLT CONNECTIONS	5.43
5.16	MAINTENANCE OF ELECTRICAL SYSTEM AND WARNING ELEMENTS	5.45
5.16.1	PRELIMINARY INFORMATION	5.45
5.16.2	REPLACEMENT OF BULBS	5.46
5.17	TROUBLESHOOTING	5.46



***SECTION***

**1**

---

**BASIC INFORMATION**

# 1.1 IDENTIFICATION

## 1.1.1 IDENTIFICATION OF MIXER FEEDER

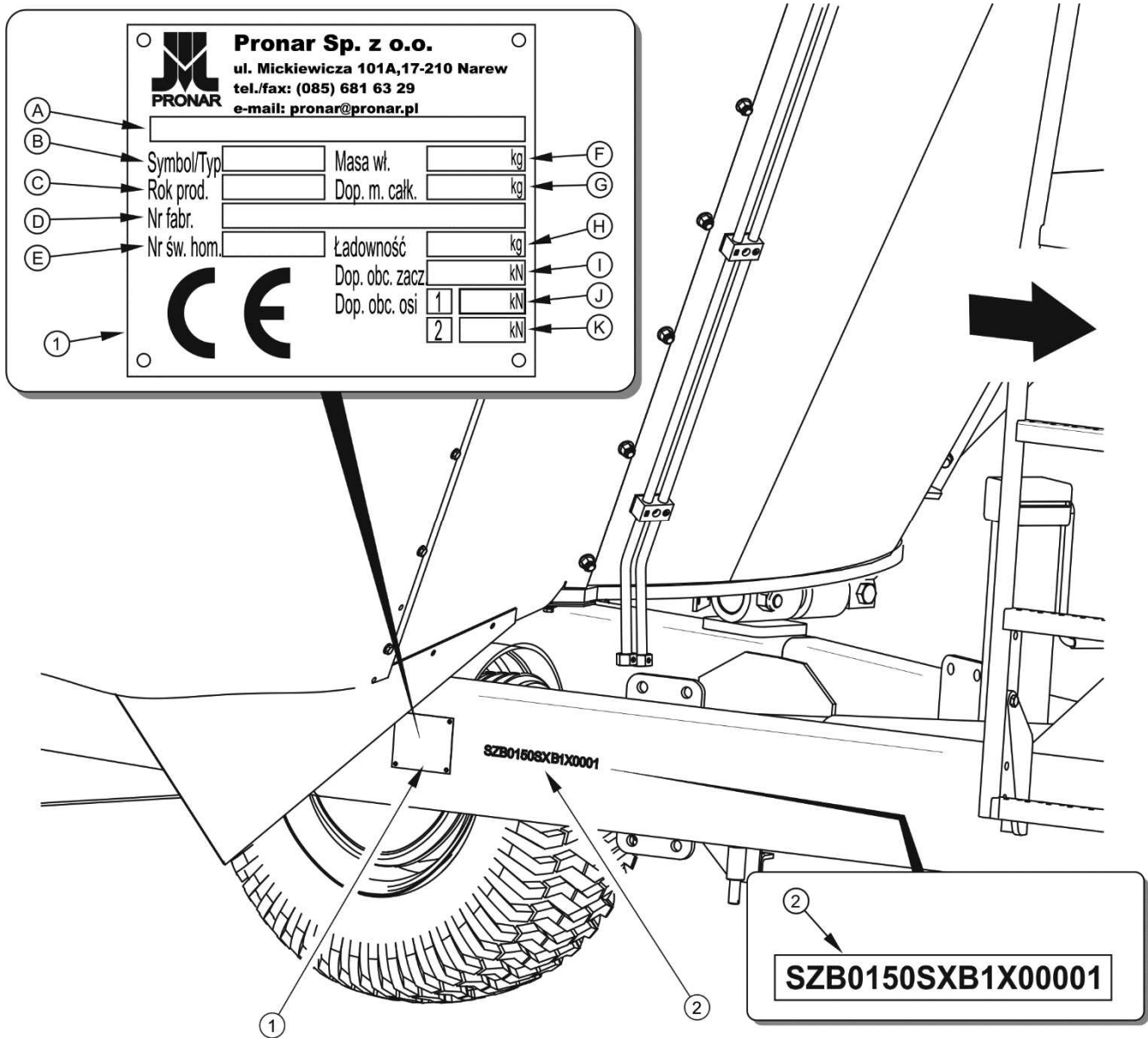

**FIGURE 1.1** Location of the data plate and serial number

(1) data plate, (2) example of serial number

Pronar VMP-10S mixer feeder is marked with the data plate (1) and the serial number (2) located on a gold painted rectangle. The serial number and the data plate are located on the right longitudinal member of the frame - figure (1.1). When buying the machine check that the serial numbers on the machine agree with the number written in the *WARRANTY BOOK* and

in the sales documents. The meanings of the individual fields found on the data plate are presented in the table below:

**TABLE 1.1 Markings on data plate**

ITEM	MARKING
A	General description and purpose
B	Symbol /Machine type
C	Year of manufacture
D	Seventeen digit serial number (VIN)
E	Official certificate number (not applicable)
F	Machine tare weight
G	Maximum gross weight
H	Carrying capacity
I	Permissible hitching system loading
J	Permissible front axle load
K	Permissible rear axle load (not applicable)

### 1.1.2 AXLE IDENTIFICATION

The serial number of the wheel axle and its type are stamped onto the data plate (2) secured to the wheel axle beam (1) – figure (1.2).

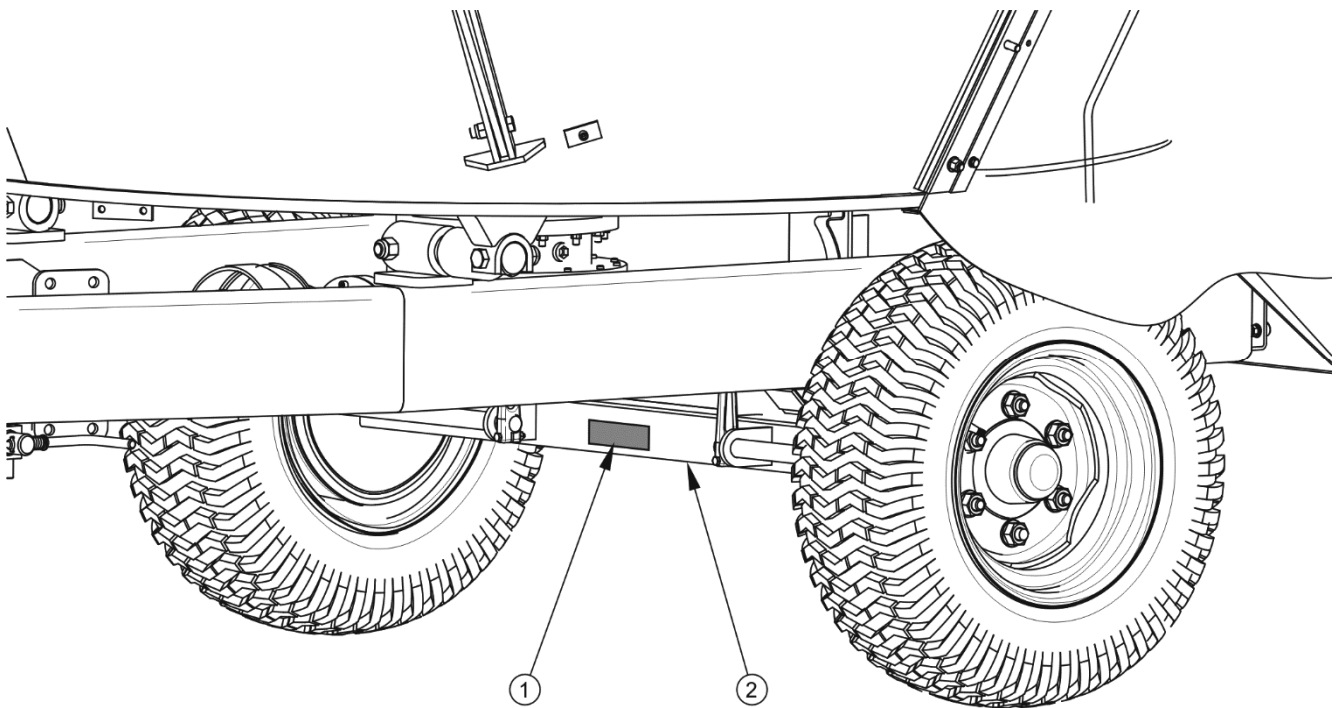

**FIGURE 1.2** Location of the axle data plate

(1) data plate, (2) wheel axle,

**1.1.3 LIST OF SERIAL NUMBERS**

**TIP**

i

In the event of ordering a replacement part or in the case of the appearance of problems it is often essential to give the serial number of the mixer feeder or the serial number of the wheel axle, therefore it is recommended that these numbers are inscribed in the table (1.2).

**TABLE 1.2** List of serial numbers

<b>VIN</b>															
S	Z	B	0	1	5	0	S	X			X				
<b>AXLE SERIAL NUMBER</b>															

## 1.2 PROPER USE

VMP-10S mixer feeder is designed specially for modern cattle breeding farms. The machine is designed for preparing feed in the animal feeding systems of TMR type (Total Mixed Ration), PMR type (Partially Mixed Ration) or similar systems. Feed ingredients are batched to the mixer feeder tank where they are disintegrated and thoroughly mixed. Preparation of nutritive fodder depends on numerous factors. That is why the nutrients should be selected in a proper manner with the assistance of a fodder specialist who can specify some feed recipes.

### **DANGER**

The mixer feeder must not be used for purposes other than those for which it is intended, in particular:



- for transporting people and animals,
- for mixing and transporting toxic and flammable materials,
- for preparing or storing food for people,
- for spreading fluids, sand or fibrous substances,
- for transporting bulk materials, single objects or any materials and substances outside the scope of intended use of the mixer feeder.

The mixer feeder is designed for preparing feed mixtures consisting of all kinds of bulky feeds (silage, hay, straw, plant flour), nutritive fodder, powder and granulate feed products made by food industry, feed preparations increasing productivity of dairy cows, vitamin preparations and mineral preparations.

The brake system and the light and indicator system meet the requirements of road traffic regulations. The maximum allowable speed of the mixer feeder is 25 km/h (the maximum design speed).

Using it as intended also involves all actions connected with the safe and proper operation and maintenance of the machine. Due to the above, the user is obliged to:

- carefully read the *OPERATOR'S MANUAL* of the mixer feeder, *WARRANTY BOOK*, the Operator's Manual of PTO shaft, the Operator's Manual of tractor and conform with the recommendations contained in these documents,

- understand the mixer feeder's operating principle and how to operate it safely and correctly,
- adhere to the established maintenance and adjustment plans,
- comply with general safety regulations while working,
- prevent accidents,
- comply with the road traffic regulations in force in a given country, in which the mixer feeder is used,
- only hitch the mixer feeder to an agricultural tractor which fulfils all the requirements specified by the mixer feeder's Manufacturer.

The machine may only be used by persons, who:

- are familiar with the contents of this publication and with the contents of the agricultural tractor Operator's Manual,
- have been trained in mixer feeder service and safe operation,
- have the required driving licence.

**TABLE 1.3 Agricultural tractor's requirements**

CONTENTS	UNIT	REQUIREMENTS
<b>Pneumatic brake system</b>		
Double conduit pneumatic system	-	sockets compliant with PN-ISO 1728:2007
Nominal pressure of the system	bar	8
Single conduit pneumatic system	-	sockets compliant with PN-ISO 1728:2007
Nominal pressure of the system	bar	5.8
<b>Hydraulic brake system</b>		
Hydraulic system	-	
Nominal pressure of the system	bar	sockets compliant with ISO 7421-1
		150
<b>Hydraulic system</b>		
Hydraulic oil	-	L HL 32 Lotos
Pressure rating of the system	MPa	16
Oil demand:	l	5

CONTENTS	UNIT	REQUIREMENTS
<b>Electrical system</b> Electrical system voltage Connection socket	V -	12 7-pole socket compliant with ISO 1724
<b>Tractor hitches</b> Minimum lift capacity (vertical load) of the hitching system	kg	1,300
<b>Other requirements</b> Minimum tractor power demand	kW(hp)	44.1 / 60

**ATTENTION**

Use of other oil is permitted on condition that it may be mixed with the oil used in the mixer feeder. Detailed information can be found on the product information card.

**TIP**

Information on gear oils is provided in section 5.

## 1.3 EQUIPMENT

**TABLE 1.4**     Equipment of mixer feeder

EQUIPMENT	STANDARD	ADDITIONAL	OPTION
<i>OPERATOR'S MANUAL</i>	•		
<i>WARRANTY BOOK</i>	•		
Single conduit pneumatic system	•		
Double conduit pneumatic system			•

EQUIPMENT	STANDARD	ADDITIONAL	OPTION
Hydraulic brake system			•
Drawbar set with rotating drawbar eye Ø50	•		
Drawbar set with fixed drawbar eye Ø40			•
Complete set of wall extensions.	•		
Hydraulic system of the slide gates	•		
Wheel chocks	•		
Slow-moving vehicle warning sign		•	
Warning reflective triangle		•	
Spill containment ring	•		
Spacer ring		•	
Counter blade lever		•	
PTO shaft B&P 7 106 081 CE 007 007 <sup>(1)</sup>		•	
PTO shaft B&P 7 106 081 CE 007 19A <sup>(2)</sup>	•		
Power transmission mechanism with planetary gear	•		
Power transmission mechanism with two-speed gear and planetary gear			•
Electric lighting system with the scales system	•		

(1) - available as optional equipment in the power transmission mechanism with planetary gear

(2) - available as standard equipment if the mixer feeder is equipped with optional power transmission mechanism with two-speed gear and planetary gear

Information on tyres is provided at the end of this publication in ANNEX A.



## 1.4 WARRANTY TERMS

PRONAR Sp. z o.o., Narew guarantees the reliable operation of the machine when it is used according to its intended purpose as described in the *OPERATOR'S MANUAL*. The repair period is specified in the *WARRANTY BOOK*.

The warranty does not cover those parts and sub-assemblies of the machine which are subject to wear in normal usage conditions, regardless of the warranty period. Consumables include the following parts/sub-assemblies:

- drawbar hitching eye,
- pneumatic system connector filters,
- tyres,
- bulbs,
- seals,
- bearings,
- brake shoes,
- cutting blades.

The warranty service only applies to such cases as: mechanical damage which is not the user's fault, factory defects of parts, etc.

In the event of damage arising from:

- mechanical damage which is the user's fault, road accidents,
- incorrect use, adjustment or maintenance, use of the mixer feeder for purposes other than those for which it is intended,
- use of damaged machine,
- repairs carried out by unauthorised persons, repairs carried out improperly,
- making unauthorised alterations to machine design,

the user will lose the right to warranty service.

**TIP**

Demand that the seller carefully and precisely fills out the **WARRANTY BOOK** and warranty repair coupons. A missing date of purchase or sale point stamp may make the user ineligible for any warranty repair or refund.

The user is obliged to report immediately on noticing any wear in the paint coating or traces of corrosion, and to have the faults rectified whether they are covered by the guarantee or not. For detailed Terms & Conditions of Warranty, please refer to the **WARRANTY BOOK** attached to each newly purchased machine.

Modification of the machine without the written consent of the Manufacturer is prohibited. In particular, do NOT weld, drill holes in, cut or heat the main structural elements of the machine, which have a direct impact on the machine operation safety.

## 1.5 TRANSPORT

The mixer feeder is ready for sale completely assembled and does not require packing. Packing is only required for the machine's technical documentation and any extra equipment. The mixer feeder is delivered to the user either transported on a vehicle or, after being attached to a tractor, independently (mixer feeder towed by a tractor).

### 1.5.1 TRANSPORT ON VEHICLE

Loading and unloading of mixer feeder from vehicle shall be conducted using loading ramp with the aid of agricultural tractor, overhead crane or hoisting crane. During work, adhere to the general principles of occupational health and safety (OHS) applicable to reloading work. Persons operating reloading equipment must have the qualifications required to operate these machines.

Lifting equipment used for transporting the mixer feeder must be attached only to the fixed structural elements of the machine. These elements are, first of all: frame, drawbar and axle.

**ATTENTION**

Do not secure or attach the mixer feeder by drawbar eye, tank, auger and other structural elements that are not sufficiently strong to withstand operations of this type.

The mixer feeder should be attached firmly to the platform of the vehicle using straps, chains, stays or other securing measures (3) – figure (1.3), fitted with a tightening mechanism. In order to attach the machine in a proper manner, fasten axles, frame longitudinal members and possibly drawbar. Additionally, support the drawbar with a wooden block (1) of such a height that the mixer feeder frame is positioned parallel to the load platform. Chocks (2), wooden blocks or other objects without sharp edges should be placed under the wheels of the mixer feeder to prevent it from rolling. Wheel blocks must be nailed to the vehicle load platform planks or secured in another manner preventing their movement.

Use certified and technically reliable securing measures. Worn straps, cracked securing catches, bent or corroded hooks as well as elements damaged in a different way may be unsuitable for use. Carefully read the information stated in the Operator's Manual for the given securing measure. The number of securing elements (cables, straps, chains and stays etc.) and the force necessary for their tensioning depend on such factors as the machine weight, the carrying vehicle design, speed of travel and other conditions. For this reason it is impossible to define the securing plan precisely.

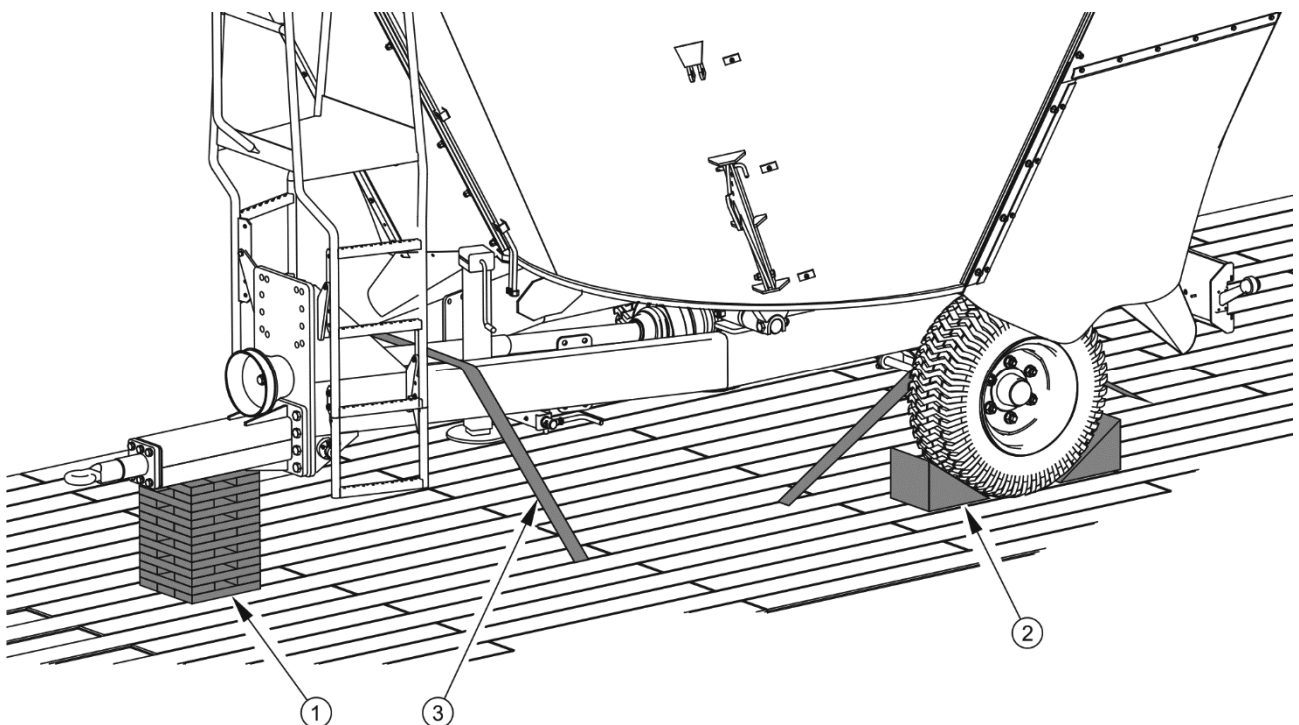

**FIGURE 1.3** Example of mixer feeder securing plan

(1) drawbar support, (2) wheel chocks, (3) securing strap

Figure (1.3) shows the minimum mixer feeder transport protection. A correctly secured machine does not change its position with regard to the transporting vehicle. The securing elements must be selected according to the guidelines of the Manufacturer of these elements. In case of doubt apply a greater number of securing straps in order to immobilise the machine. If necessary, cover the sharp edges of the mixer feeder in order to protect the securing straps from breaking during transport.



## **DANGER**

**Incorrect use of securing measures may cause an accident.**

During reloading work, particular care should be taken not to damage parts of the machine's equipment or the paint coating. The tare weight of the mixer feeder is given in table (3.1).



## **ATTENTION**

**When being road transported on a motor vehicle, the mixer feeder must be secured on the vehicle's platform in accordance with the transport safety requirements and regulations.**

**Driver of the vehicle should be particularly careful during travel. This is due to the vehicle's centre of gravity shifting upwards when loaded with the machine.**

**Use only certified and technically reliable securing measures. Carefully read the information contained in the Operator's Manuals for the given securing measures.**

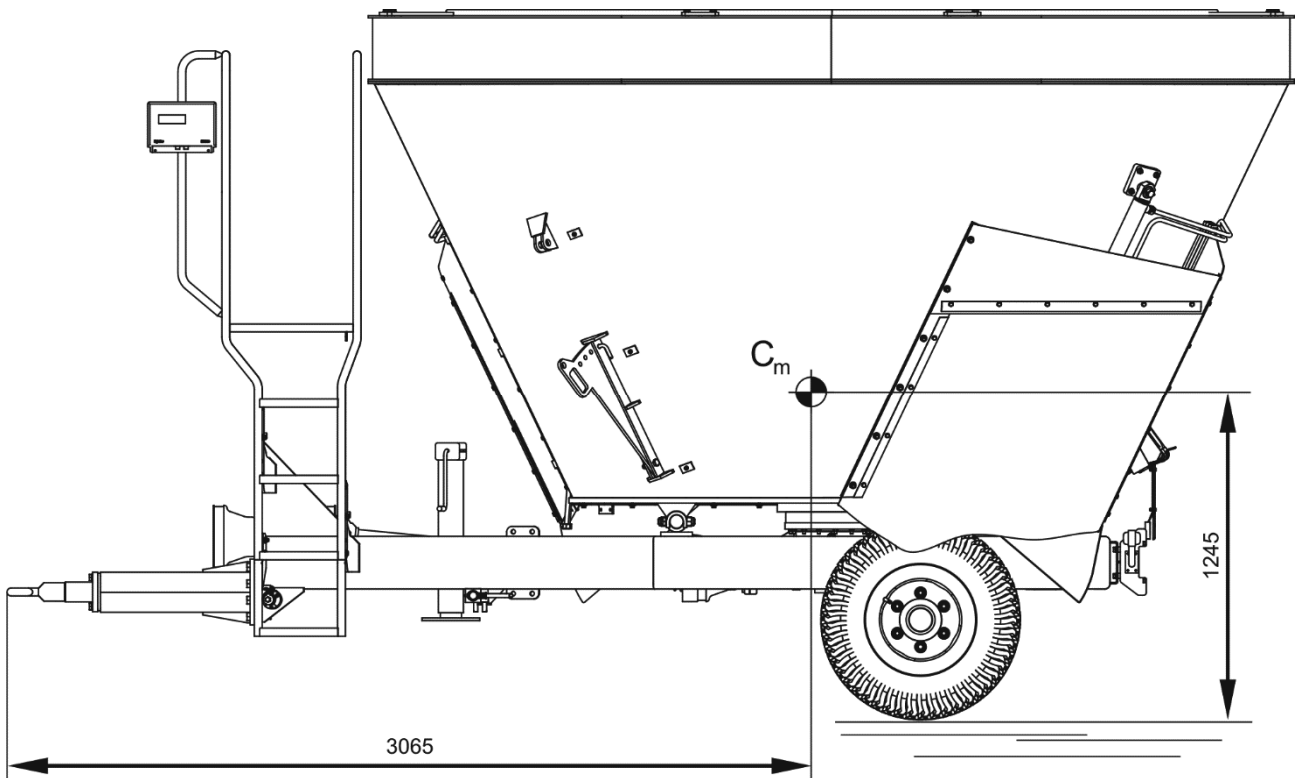

**FIGURE 1.4** Location of centre of gravity of the mixer feeder

### 1.5.2 INDEPENDENT TRANSPORT BY THE USER

In the event of independent transport by the user, carefully read *THE OPERATOR'S MANUAL* and follow its recommendations. Independent transport involves towing the machine with own agricultural tractor to destination. During transport adjust travel speed to the prevailing road conditions, but do not exceed the maximum design speed.



#### **ATTENTION**

Before transporting independently, the tractor driver must carefully read this Operator's Manual and observe its recommendations.

## 1.6 ENVIRONMENTAL HAZARDS

A hydraulic or gear oil leak constitutes a direct threat to the natural environment owing to its limited biodegradability. The negligible solubility of hydraulic oil in water does not cause extreme toxicity of organisms living in the aquatic environment. The formation of a film of oil

on the water may be the direct cause of physical action on organism, perhaps causing change of oxygen values in the water because of lack of direct contact of air with the water. An oil leak into water reservoirs may however lead to a reduction of the oxygen content.

While carrying out maintenance and repair work, which involves the risk of an oil leak, this work should take place on an oil resistant floor or surface. In the event of oil leaking into the environment, first of all contain the source of the leak, and then collect the leaked oil using available means. Remaining oil should be collected using sorbents, or by mixing the oil with sand, sawdust or other absorbent materials. The oil pollution, once gathered up, should be kept in a sealed, marked, hydrocarbon resistant container. The container should be kept away from heat sources, flammable materials and food.

**DANGER**

Used hydraulic or gear oil or gathered remains mixed with absorbent material should be stored in a precisely marked container. Do not use food packaging for this purpose.

Used oil or oil unsuitable for further use due to loss of its properties should be stored in its original packaging in the conditions described above. Waste oil should be taken to the appropriate facility dealing with the re-use of this type of waste. Waste code (L-HL 32 Lotos hydraulic oil): 13 01 10. Detailed information concerning hydraulic oil may be found on the product's Material Safety Data Sheet.

**TIP**

The hydraulic system of the mixer feeder is filled with L-HL 32 Lotos hydraulic oil. Please refer to Section 5 for information on transmission oil used.

**ATTENTION**

Waste oil should only be taken to the appropriate facility dealing with the re-use of this type of waste. Do NOT throw or pour oil into sewerage or water tanks.

## 1.7 WITHDRAWAL FROM USE

In the event of decision by the user to withdraw the mixer feeder from use, comply with the regulations in force in the given country concerning withdrawal from use and recycling of machines withdrawn from use. Before proceeding to dismantle equipment oil shall be completely removed from hydraulic system and gearbox.

### **DANGER**



During dismantling, use the appropriate tools, equipment (overhead travelling crane, crane or hoist etc.) and use personal protection equipment, i.e. protective clothing, footwear, gloves and eye protection etc.

Avoid contact of skin with oil. Do not allow used hydraulic oil to spill.

Worn out or damaged parts that cannot be reclaimed should be taken to a collection point for recyclable raw materials. Hydraulic and gear oil should be taken to the appropriate facility dealing with the recycling of this type of waste.





**SECTION**

**2**

---

**SAFETY ADVICE**

## 2.1 BASIC SAFETY RULES

### 2.1.1 BASIC SAFETY RULES

- Before using the mixer feeder, the user must carefully read this Operator's Manual and the Operator's Manual of the PTO shaft. During use all the recommendations laid down in this Operator's Manual should be observed. Do NOT start the mixer feeder without knowledge of its function.
- The user is obliged to acquaint himself with the construction, action and the principles of safe usage of the machine.
- Before using the mixer feeder always check the machine, whether it is properly prepared for work, especially in terms of safety.
- If the information contained in the Operator's Manual is difficult to understand, contact a seller, who runs an authorised technical service on behalf of the manufacturer, or contact the manufacturer directly.
- Careless and incorrect use and operation of the mixer feeder and also non-observance of the recommendations contained in this Operator's Manual, endanger health and life third persons and/or machine operator.
- Be aware of the residual risk. Use caution when operating the mixer feeder and apply all relevant safety principles.
- The machine must never be used by persons who are not authorised to drive the agricultural tractors and not trained in the safety principles and use of the machine, including children and people under the influence of alcohol.
- Do NOT use the mixer feeder for purposes other than those for which it is intended. Anyone who uses the machine in any other way than the way intended takes full responsibility for any consequences of this use. Use of the machine for purposes other than those for which it is intended by the Manufacturer may invalidate the warranty.
- Use close fitting protective clothing.
- Any modification to the mixer feeder frees the manufacturer from any responsibility for damage or detriment to health which may arise as a result.

- Before using the machine always check its technical condition, and in particular: technical condition of the drawbar, hydraulic system, safety guards and air pressure in tyres.
- The user is obliged to acquaint himself with the principles of safe operation, adjustment methods and inspection points of the mixer feeder and with the risks resulting from operation and maintenance of the machine.
- People, animals or objects must not be carried on the machine.
- The mixer feeder may be operated only by one person at a time.

### **2.1.2 HITCHING AND UNHITCHING FROM TRACTOR**

- Be especially careful when hitching and unhitching the machine.
- Only hitch the mixer feeder to an agricultural tractor equipped with side mirrors, which provide visibility on both sides of the machine.
- While hitching the mixer feeder to the tractor, use the appropriate hitch (the upper or lower transport hitch). After completed hitching of the machines check that the hitch is properly secured. Carefully read the tractor Operator's Manual. If the tractor is equipped with an automatic hitch, make certain that the coupling operation is completed.
- When hitching, there must be nobody between the mixer feeder and the tractor.
- Do NOT hitch the mixer feeder to agricultural tractor, if the tractor does not meet the requirements specified by the Manufacturer (minimum tractor power demand, wrong connections etc.) – compare table (1.3) *AGRICULTURAL TRACTOR'S REQUIREMENTS*. Before hitching the machine, make certain that oil in the external hydraulic system of tractor may be mixed with the hydraulic oil in the machine's hydraulic system.
- When connecting the hydraulic conduits to the tractor, make sure that the hydraulic systems of the tractor and mixer feeder are not under pressure. If necessary, reduce residual pressure in the system.
- Before hitching the mixer feeder, check that both machines are in good technical condition. In particular, check the hitching system and hydraulic system connectors and sockets on the tractor and mixer feeder.

- The machine unhitched from the tractor must be positioned on a level ground, supported by the parking stand and secured against rolling using wheel chocks. Terminals of hydraulic and electrical conduits should be protected against contamination.

### **2.1.3 LOADING THE MIXER FEEDER AND FEED MIXING**

- Before loading the mixer feeder, ensure proper visibility of the mixer feeder and the danger zone. Make certain that there are no bystanders in the loading zone near the machine and that there are no obstacles preventing proper machine operation. There must be sufficient space to ensure efficient loading of bales into the mixer feeder tank.
- The bales to be loaded must not contain remains of wrapping twine, net or film.
- Make certain that both slide gates are completely closed.
- Do NOT exceed the mixer feeder's maximum carrying capacity.
- Do NOT remove feed clogging during auger operation. In order to remove clogging, stop the mixer feeder drive, stop the engine and remove key from ignition.
- During loading the mixer feeder, the drawbar eye and the tractor hitch are subjected to great vertical loads.
- Maintain constant auger rotation speed while mixing the feed.
- Do not exceed the maximum rotational speed of drive shaft.
- During manual loading, do NOT stand on a silo or hay stack located above the mixer feeder tank edge.

### **2.1.4 HYDRAULIC SYSTEM**

- The hydraulic system is under high pressure when the mixer feeder is working.
- Regularly check the technical condition of the hydraulic connections and conduits. There must not be any leaks of hydraulic oil.
- In the event of the hydraulic system malfunction, discontinue using the mixer feeder until the malfunction is corrected.

- Before proceeding to maintenance-repair work, make certain that the hydraulic system is not under pressure.
- Rubber hydraulic conduits must be replaced every 4 years regardless of their technical condition.
- Use the hydraulic oil recommended by the Manufacturer.
- After changing the hydraulic oil, the used oil should be properly disposed of. Used oil or oil which has lost its properties should be stored in original containers or replacement containers resistant to action of hydrocarbons. Replacement containers must be clearly marked and appropriately stored.
- Do not store hydraulic oil in packaging designed for storing food or foodstuffs.

### **2.1.5 OPERATING PTO SHAFT.**

- The user should thoroughly acquaint himself with the PTO shaft Operator's Manual and adhere to the recommendations contained in it.
- The machine may only be connected to the tractor by appropriately selected PTO shaft. Use PTO shaft recommended by the Manufacturer.
- The drive shaft must be equipped with guards. Do NOT use the shaft with damaged or missing guards. Before starting the machine, always ensure that all the safety guards are in good condition and in place. Damaged or incomplete sub-assemblies must be exchanged for original new ones.
- After connecting shaft ensure that it is correctly and safely connected to the tractor and to the machine.
- Do NOT wear loose clothing, straps or whatever that may become wrapped round the rotating drive shaft. Contact with rotating PTO shaft may cause severe injuries.
- Before connecting or disconnecting the shaft, turn off the tractor engine and remove the key from the ignition. Immobilise the tractor with parking brake.
- When working in limited visibility conditions, use the tractor's working lights to illuminate the PTO shaft and its vicinity.

- During transport, the shaft must be stored in the horizontal position to avoid damage to safety guards or other protection elements.
- During shaft operation, the telescopic pipes must overlap by at least one third of their length.
- When using the mixer feeder and PTO shaft, do not use PTO shaft rotation speed other than 540 rpm. Do NOT overload the shaft and the mixer feeder and also do NOT engage the clutch suddenly. Before starting PTO, make certain that the PTO rotation direction is correct.
- The chains preventing the shaft cover from turning while the shaft is working should be secured to a fixed element of machine structure.
- Do NOT use the securing chains to support the shaft while the mixer feeder is parked or when transporting the mixer feeder.
- Do NOT go over and under the shaft or stand on it equally during work as also when the machine is parked.
- The PTO shaft has markings on the casing, indicating, which end of the shaft should be connected to the tractor.
- Never use a damaged PTO shaft, it may cause an accident. A damaged shaft must be repaired or replaced.
- Disconnect the drive shaft each time when it is not necessary to drive the machine, or when the tractor and mixer feeder are at an unsuitable angle to each other.

### **2.1.6 CLEANING, MAINTENANCE AND ADJUSTMENT**

- Maintenance and repair works may be performed after hitching the mixer feeder to the tractor. In such a case, switch off the tractor engine, remove the key from the ignition and immobilise the tractor with parking brake. Ensure that unauthorised persons do not have access to the tractor cab. Protect the machine against rolling by placing blocking chocks under the wheels. Disconnect the PTO shaft from the tractor before entering the mixer feeder tank. When performing works that do not require hitching to tractor, position the mixer feeder on level and hard surface, support it using a parking stand and protect it against rolling by

placing chocks under the wheels and applying parking brake. Place of work should be dry, clean and well-lighted.

- Regularly check the condition of the bolt and nut connections.
- During the warranty period, any repairs may only be carried out by the Warranty Service authorised by the Manufacturer. After the expiry of the warranty period it is recommended that possible repairs to the machine be performed by specialised workshops.
- During work use the proper, close-fitting protective clothing, gloves, protective goggles and appropriate tools.
- In the event of any fault or damage, do not use the machine until the fault has been corrected.
- Servicing and repair work should be carried out in line with the general principles of workplace health and safety. In the event of injury, the wound must be immediately cleaned and disinfected. In the event of more serious injuries, seek a doctor's advice.
- Service inspections of the mixer feeder should be carried out according to the frequency specified in this Operator's Manual.
- Welding works may be performed only by persons having appropriate authorisations for this type of works.
- Before welding or electrical work, the mixer feeder should be disconnected from the power supply (disconnect the negative battery cable (-) from the tractor battery, disconnect connection lead). The paint coating should be cleaned. Burning paint fumes are poisonous for people and animals. Welding work should be carried out in a well lit and well ventilated space.
- In order to reduce the risk of fire, remove the remains of feed accurately from the mixer feeder before welding works. Be especially careful when welding and pay attention to flammable or fusible elements (hydraulic system conduits, electrical system leads and other structural elements made of plastics). If there is a risk that they will catch fire or be damaged, they should be removed or covered with non-flammable material before commencing welding work. Before beginning work, prepare a CO<sub>2</sub> or foam extinguisher.

- In the event of work requiring the mixer feeder to be raised, use properly certified hydraulic or mechanical lift jacks for this purpose. After lifting the machine, stable and durable supports must also be used. Do NOT carry out work under a machine, which has only been raised with the lift jack.
- The machine must not be supported using fragile elements (bricks or concrete blocks).
- After completing work associated with lubrication, remove excess oil or grease. The machine should be kept clean and tidy.
- The user must not repair by himself the hydraulic cylinders. In the event of damage to these elements, repair should be entrusted to authorised service point or elements should be replaced with new ones.
- Do NOT make repairs to drawbar (straightening, pad welding or welding). A damaged drawbar must be replaced.
- Do NOT install additional appliances or fittings not according to the specifications defined by the Manufacturer.
- The mixer feeder may only be towed when axles and wheels, main brake system and lighting system are reliable.
- Regularly check technical condition and mounting of all guards and protective elements.
- Should it be necessary to change individual parts, use only original parts or those indicated by the Manufacturer. Non-adherence to these requirements may put the user and other people's health and life at risk, and also damage the machine.
- In the event of injuries being caused by pressurised hydraulic oil, contact a doctor immediately. Hydraulic oil may penetrate the skin and cause infections. In the event of contact of oil with eyes, rinse eyes with a large quantity of water and in the event of the occurrence of irritation consult a doctor. In the event of contact of oil with skin wash the area of contact with water and soap. Do NOT apply organic solvents (petrol, kerosene).
- After completed work, make sure that no tools are left inside the mixer feeder tank.



- Regularly check the condition of the bolt and nut connections.
- The machine may only be stood on when it is absolutely motionless and the tractor engine is switched off. During the mixer feeder operation, the operator may climb the mixer feeder's platform only in order to check the process of feed mixing and disintegrating while exercising due caution and paying proper attention.
- The mixer feeder, in particular its tank and auger, should be kept clean and tidy.
- Adjustment of blades may be performed only when the auger is motionless and the tractor is immobilised with parking brake.
- Before entering the tank, turn off the tractor's engine, immobilise the tractor with parking brake, secure the tractor against unauthorised access, dismantle PTO shaft, open the slide gates and disconnect the hydraulic system conduits from the tractor. Exercise particular caution when entering the tank.
- While entering the tank, the mixer feeder must be absolutely motionless. Use two sufficiently high ladders to enter the tank. Do NOT use the platform and chute for this purpose.
- Since the cutting blades are very sharp, exercise due caution when mounting, dismounting or adjusting the blades or when being inside the tank.
- Remove the remains of feed from the mixer feeder each time after finished work.
- There is a risk of propagation of microorganisms in the environment if the mixer feeder is used in several farms. This risk can be minimised by careful cleaning of the machine.
- The mixer feeder that has been used for mixing contaminated feed must be disinfected according to the recommendations of sanitary authorities.
- Clean the machine thoroughly if it has not been used for more than three days.
- The development of bacterial flora is a normal phenomenon that is more intense when using feed preparations for making feed mixtures. Therefore, the cleanliness of the mixer feeder is the prerequisite for keeping the animals healthy.

### 2.1.7 DRIVING ON PUBLIC ROADS

- When travelling, adjust travel speed to road conditions. If possible avoid travelling on uneven terrain and unexpected turning. Comply with road traffic regulations.
- Do NOT exceed permissible travel speed. Excessive speed may cause loss of control over the tractor-mixer feeder combination and damage to mixer feeder and/or tractor and may limit braking efficiency of the tractor-mixer feeder combination.
- Before moving check that the mixer feeder is correctly hitched to the tractor (in particular check security of hitching pin).
- Vertical load borne by the mixer feeder's drawbar eye affects the steering of the agricultural tractor.
- While driving on public roads, the agricultural tractor must be fitted with a certified or authorised reflective warning triangle.
- Place the slow-moving vehicle warning sign on the light support beam – figure (2.1).

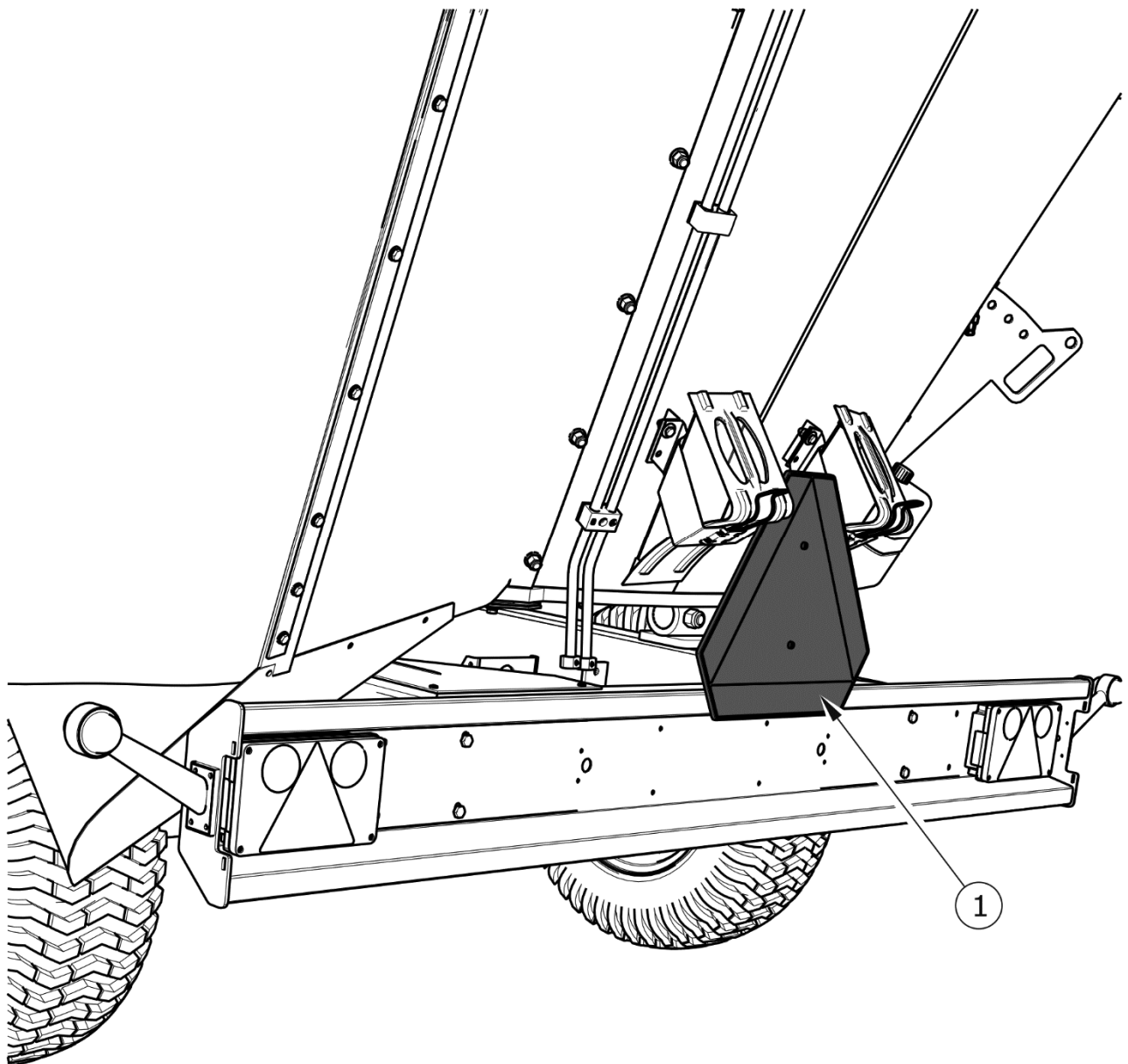
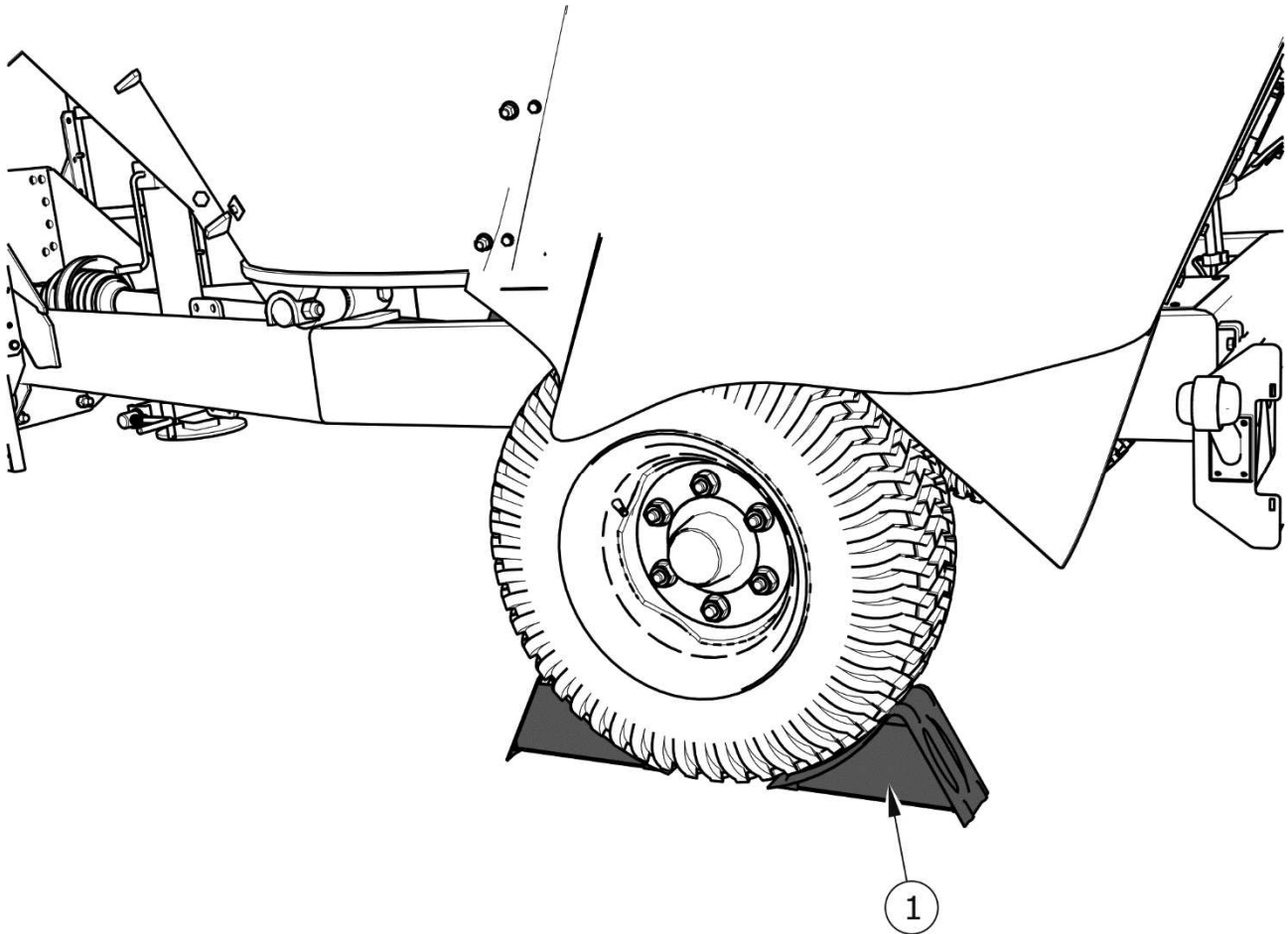

**FIGURE 2.1** Mounting place for slow-moving vehicle warning sign

(1) *warning sign*

- Electrical lighting system components and signalling components must be kept in good technical condition. The user is obliged to keep these components clean and ensure good visibility of the machine for other public road users.
- Damaged lighting system components and signalling components must be repaired or replaced with new ones before driving on the public roads.
- The machine must NOT be left unsecured. The mixer feeder unhitched from the tractor must be secured against rolling away by means of parking brake and

wheel chocks placed under the wheel - figure (2.2). The wheel chocks should be placed under one axle, in front and behind the wheel.



**FIGURE 2.2** Method of placing chocks

(1) chock

- Do NOT climb the mixer feeder while travelling.
- Do NOT park the mixer feeder on a slope.

### 2.1.8 TYRES

- When working with tyres, the mixer feeder must be secured against rolling away by means of parking brake and wheel chocks placed under the wheel. Wheels can be taken off the machine axle only when the machine is not loaded.
- Repair work on the wheels or tyres should be carried out by persons trained and entitled to do so. This work should be carried out using appropriate tools.

- Inspect tightness of nuts after the first use of the mixer feeder, after the first travel under load and then every 6 months of use or every 25,000 km. In the event of intensive work, check the nut tightening at least every 100 km. The inspection should be repeated individually if a mixer feeder wheel has been removed from the wheel axle.
- Avoid potholes, sudden manoeuvres and excessive speeds when turning.
- Check the tyre pressure regularly. Air pressure in tyres should be also checked during the whole day of intensive work. Please note that higher temperatures could raise tyre pressure by as much as 1 bar. At high temperatures and pressure, reduce load or speed. Do not release air from warm tyres to adjust the pressure or the tyres will be underinflated when temperatures return to normal.
- Protect tyre valves using suitable caps to avoid soiling.

### **2.1.9 DESCRIPTION OF RESIDUAL RISK**

Pronar Sp. z o. o. in Narew has made every effort to eliminate the risk of accidents. There is, however, a certain residual risk, which could lead to an accident, and this is connected mainly with the actions described below:

- using the mixer feeder for purposes other than those described in the Operator's Manual,
- being between the tractor and the machine while the engine is running and when the machine is being hitched,
- being on the machine while the engine is running,
- using unreliable PTO shaft,
- operating the mixer feeder with the safety guards removed or faulty,
- not maintaining a safe distance while the mixer feeder is in operation,
- operation of the mixer feeder by unauthorised persons or persons under the influence of alcohol
- cleaning, maintenance and technical inspection of the mixer feeder.
- work of machine on unstable and sloping surface.



The residual risk may be kept to a minimum by following the recommendations below:

- operate the machine in prudent and unhurried manner,
- adhere to the remarks and recommendations contained in the Operator's Manual of the mixer feeder and the Operator's Manual of PTO shaft,
- maintain a safe distance from the danger zones,
- a ban on being on the machine when it is operating, except the places specially designed for this purpose,
- carry out repair and maintenance work in line with operating safety rules,
- use close fitting protective clothing,
- ensure unauthorised persons have no access to the machine, especially children.

## **2.2 INFORMATION AND WARNING DECALS**

The mixer feeder is marked with information and warning decals referred to in table (2.1). The symbols are positioned as presented in figures (2.2) and (2.3). Throughout the time the machine is in use, the user of the machine is obliged to ensure that notices and warning and information symbols located on the mixer feeder are clear and legible. In the event of their destruction, they must be replaced with new ones. Safety decals are available from your PRONAR dealer or directly from PRONAR customer service. New assemblies, changed during repair, must be labelled once again with the appropriate safety signs. While cleaning the mixer feeder, do not use solvents which may damage the coating of information labels and do not subject them to strong water jets.

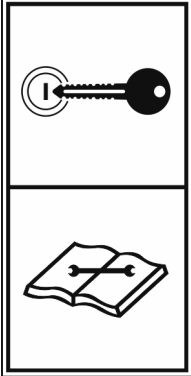
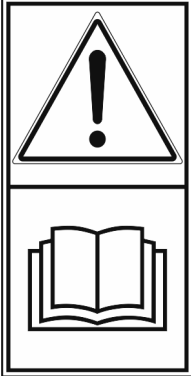
TABLE 2.1 Information and warning decals

ITEM	SAFETY SYMBOL	DESCRIPTION
		<p>Before servicing activities or repairs, turn off engine and remove key from ignition</p>
		<p>Caution! Before starting work, carefully read the Operator's Manual</p>
		<p>Danger of crushing hands or fingers. Do NOT touch the machine components until all machine assemblies have come to a standstill.</p>
		<p>Before climbing the ladder in order to perform maintenance or repair inside the tank, turn off engine and remove key from ignition. Secure tractor against unauthorised access.</p>





ITEM	SAFETY SYMBOL	DESCRIPTION
		<p>Rotation direction and maximum speed of PTO shaft.</p>
	<p><b>PRONAR VMP-10S</b></p>	<p>Machine type</p>
	<p><b>800 kPa</b></p>	<p>Air pressure in the tyres</p>
		<p>Grease the machine according to the lubrication schedule included in the <i>OPERATOR'S MANUAL</i></p>
		<p>Regularly check if the nuts and bolts fixing the wheels and other components are properly tightened.</p>
		<p>The maximum design speed of the mixer feeder.</p>
		<p>Caution!                      Danger of entrapment of the body parts or the whole body by rotating components of the mixer feeder.</p>





FIGURE 2.3 Locations of information and warning decals

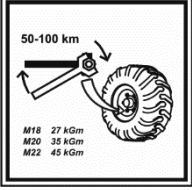

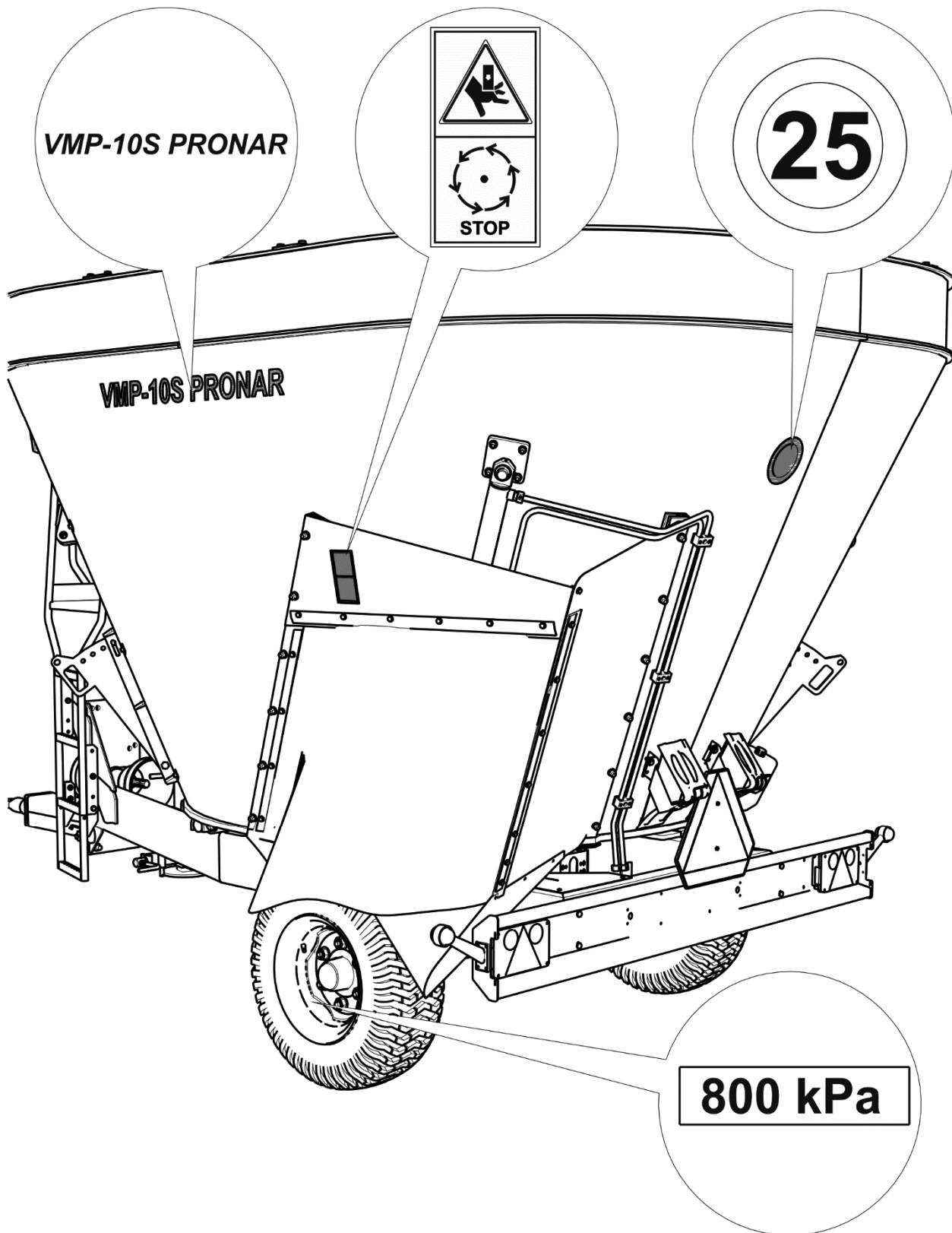
**FIGURE 2.4** Locations of information and warning decals

*SECTION*

**3**

---

**DESIGN AND  
OPERATION**

## 3.1 TECHNICAL SPECIFICATION

**TABLE 3.1 Basic technical specification**

CONTENTS	UNIT	DATA
<b>Dimensions</b>		
Total length	mm	4,860
Total width	mm	2,490
Total height	mm	2,700
<b>Tank dimensions:</b>		
Length	mm	3,530
Width	mm	2,490
Height without wall extension	mm	1,588
Height with wall extension	mm	1,838
<b>Weight and carrying capacity</b>		
Tare weight	kg	3,700
Gross weight	kg	7,700
Carrying capacity	kg	4,000
<b>Hydraulic oil demand</b>		
Hydraulic system of the slide gates	l	5
Hydraulic brake system	l	0.5
<b>Other information</b>		
Wheel track	mm	1,700
Capacity of tank with wall extension	m <sup>3</sup>	10
Tractor power demand	hp / kW	60 / 44.1
Maximum design speed	km/h	25
Electrical system voltage	12	12
Maximum vertical drawbar load	kg	1,300
Sound power level	dB	below 70
Height of tank bottom from the ground	mm	820

CONTENTS	UNIT	DATA
<b>Drive system – standard version</b>		
Type of connection shaft	-	7 106 081 CE 007 007
PTO RPM	rpm	540
Maximum torque	Nm	2,100
Auger mixer rotation speed	rpm	25
<b>Drive system – optional version</b>		
Type of connection shaft	-	7 106 081 CE 007 19A
PTO RPM	rpm	540
Maximum torque	Nm	2,100
Auger mixer rotation speed		
I speed	rpm	17
II speed	rpm	33

## 3.2 DESIGN OF MIXER FEEDER

### 3.2.1 CHASSIS

The mixer feeder chassis consists of the subassemblies indicated in figure (3.1). Lower frame (1) is a structure welded from steel sections. The main load-bearing elements are two longitudinal members. The sockets for mounting the scales load cells (5) and the tank are welded in the central part of the frame. Lights support beam (6) is bolted to the closing profile located in the rear part of the lower frame. Drawbar (2) with drawbar eye (3), platform (4) and mixer feeder support (7) are located at the front of the lower frame. The sockets and holders for securing the plugs of hydraulic and pneumatic conduits of the parked mixer feeder are bolted to the platform.

In the rear part of the lower frame, there is a wheel axle (9) made from a square bar ended with pins on which wheel hubs are mounted on cone bearings. The wheel hubs are equipped with shoe brakes activated by mechanical cam expanders. The actuators that activate the brakes are pneumatic or hydraulic cylinders, depending on the mixer feeder equipment.

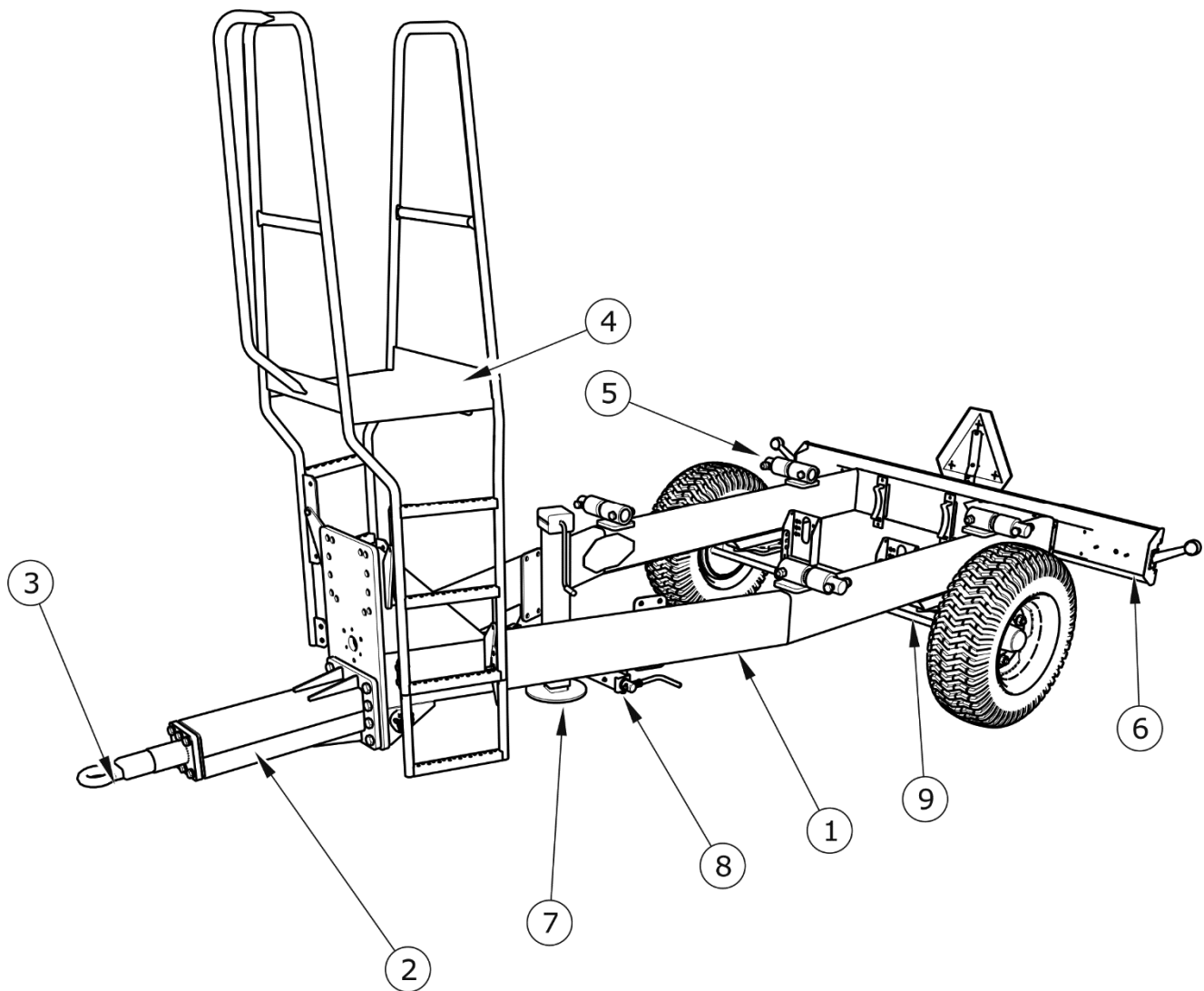
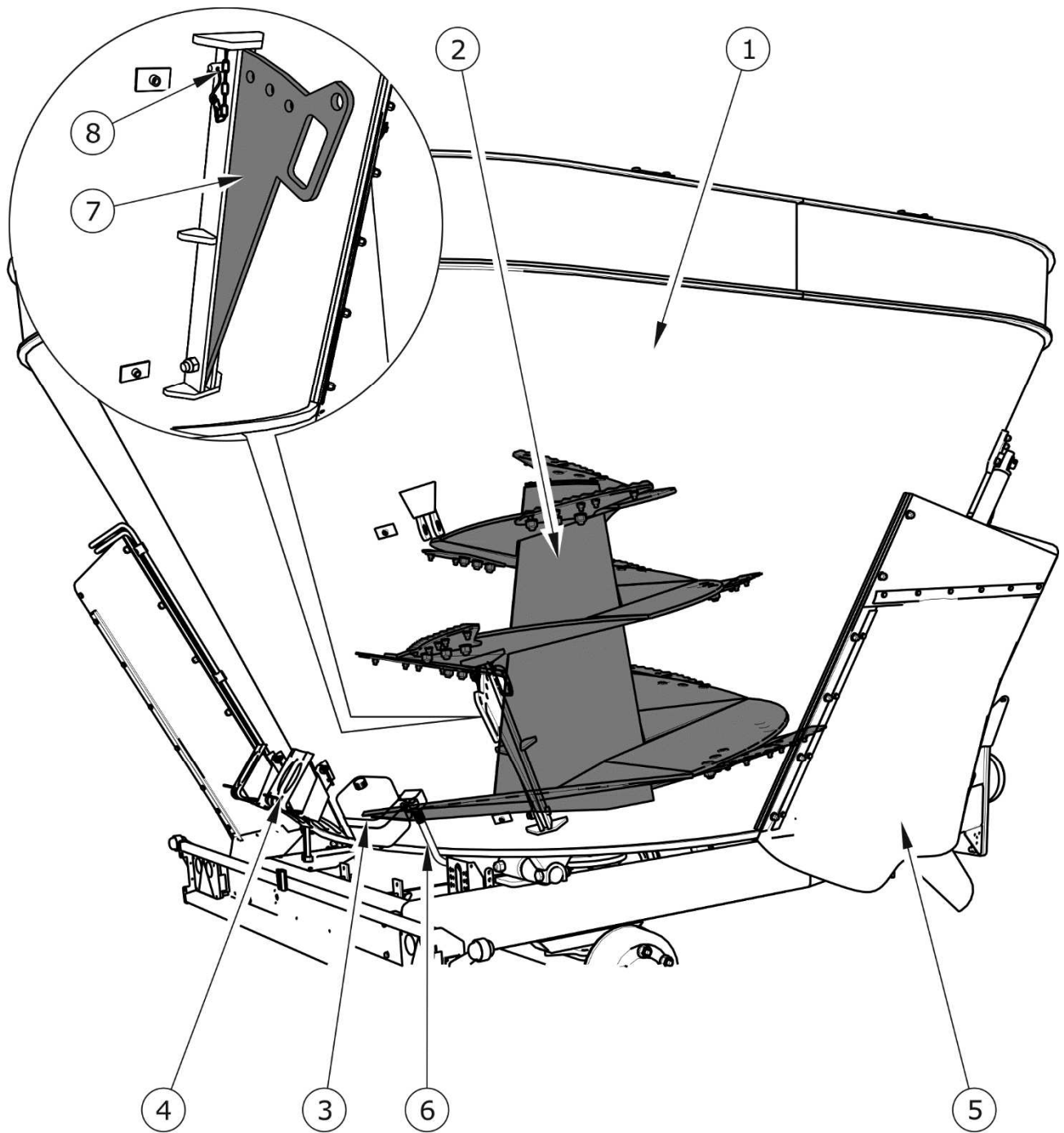

**FIGURE 3.1 Chassis**

(1) lower frame, (2) drawbar, (3) drawbar eye, (4) platform, (5) scales load cells, (6) lights support beam, (7) support, (8) parking brake crank mechanism, (9) wheel axle

### 3.2.2 TANK

The design of the mixer feeder tank is shown in figures (3.2), (3.3) and (3.4). The tank is mounted on the chassis frame using tensometric sensors (scales load cells) – compare figure (3.1). In the rear part of the tank there are chock handles (4) – figure (3.2), transmission lubricating oil tank (3) and transmission bleed conduit (6). Slide gates of dispensing windows, arranged asymmetrically with regard to the machine plane, are secured with shields (5). The drive transmission, to which the auger mixer (2) is bolted, is mounted at the tank bottom.



**FIGURE 3.2 Mixer feeder tank**

(1) tank, (2) auger mixer, (3) transmission lubrication tank, (4) wedges, (5) guard, (6) bleed conduit, (7) disintegrating knife, (8) pin

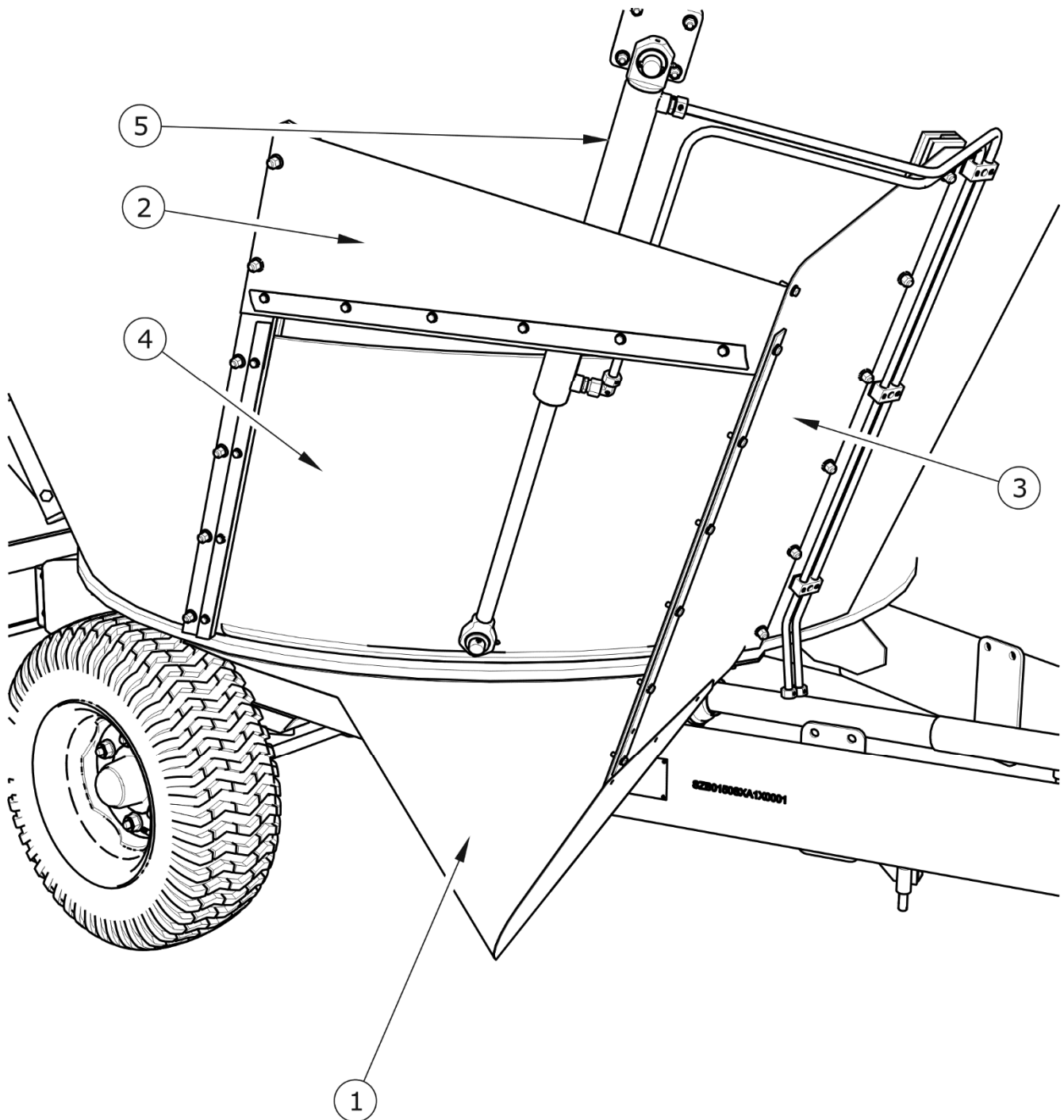

**FIGURE 3.3**     **Dispensing window in the tank**

*(1) chute – lower shield, (2) upper shield, (3) side shield, (4) slide gate, (5) hydraulic cylinder*

In the side walls of the tank, there are dispensing windows closed with slide gates (4) – figure (3.3). The slide gates are controlled independently by the hydraulic system. The chutes (1) for dispensing feed are located under the dispensing windows. The set of 250 mm-high wall extensions (1) is attached to the top edge of the tank – figure (3.4). Wall extensions are



available as standard equipment. Spill containment ring (2) is attached to the wall extensions in order to prevent spillage of mixed feed to the outside of the tank.

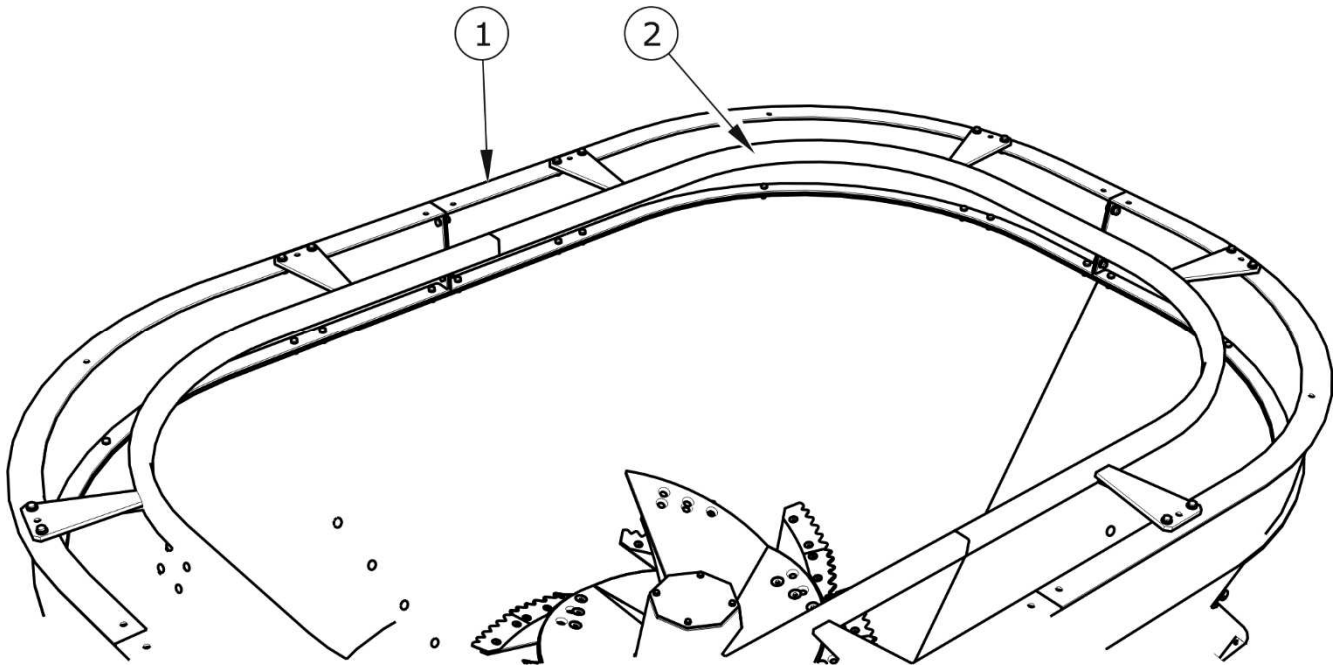

**FIGURE 3.4** Tank wall extension

*(1) 2 mm wall extension, (2) ring*

### 3.2.3 MAIN BRAKE

The mixer feeder is equipped with one of the three types of main brake:

- single conduit pneumatic system with three-position regulator, figure (3.5) – standard equipment,
- double conduit pneumatic system with three-position regulator, figure (3.6) – optional equipment,
- hydraulic braking system, figure (3.7) – optional equipment.

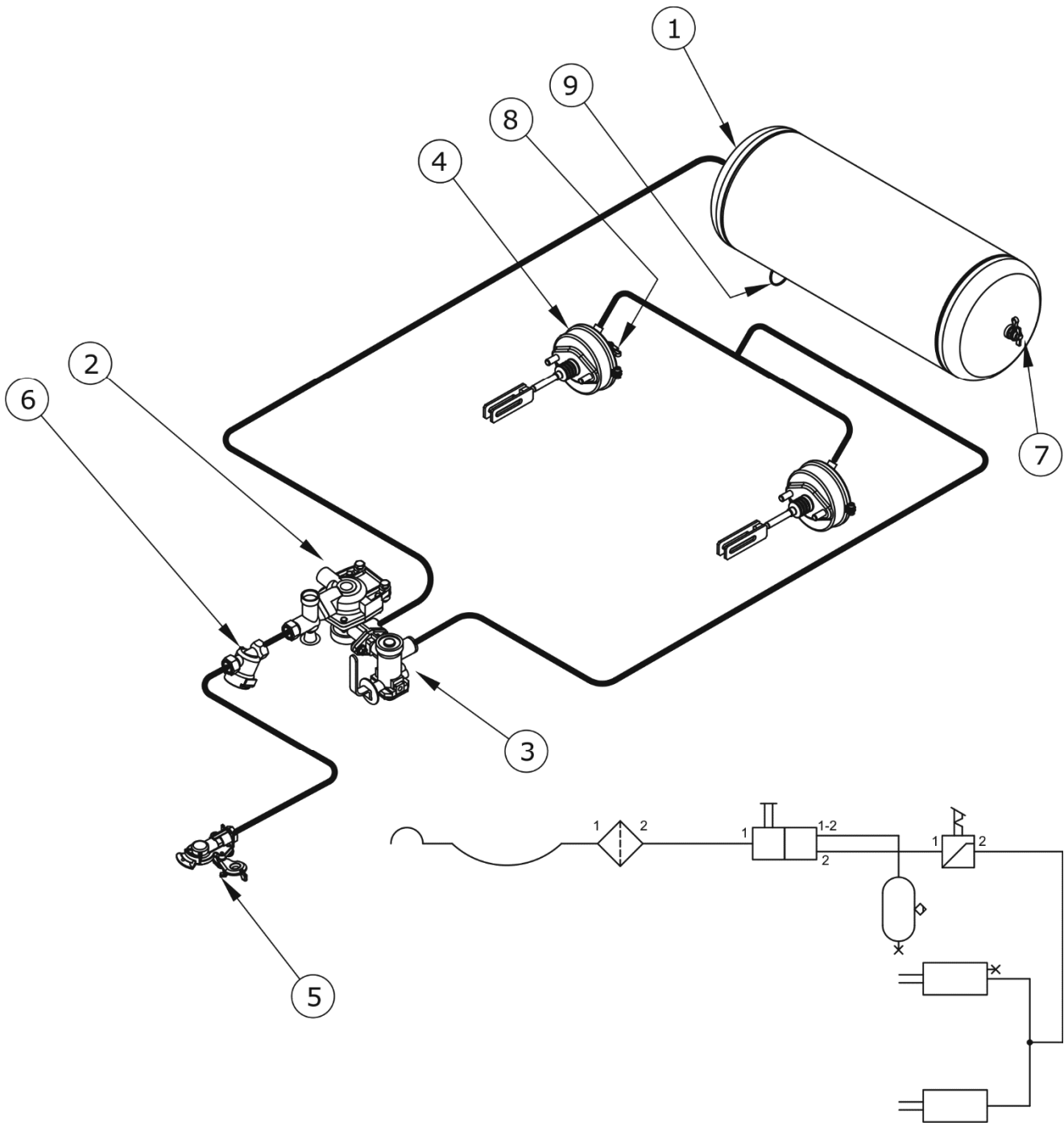

**FIGURE 3.5** Design and diagram of the single conduit pneumatic braking system  
 (1) air tank, (2) control valve, (3) braking force regulator, (4) pneumatic cylinder, (5) conduit connection, (6) air filter, (7) air tank control connector, (8) pneumatic cylinder control connector, (9) drain valve

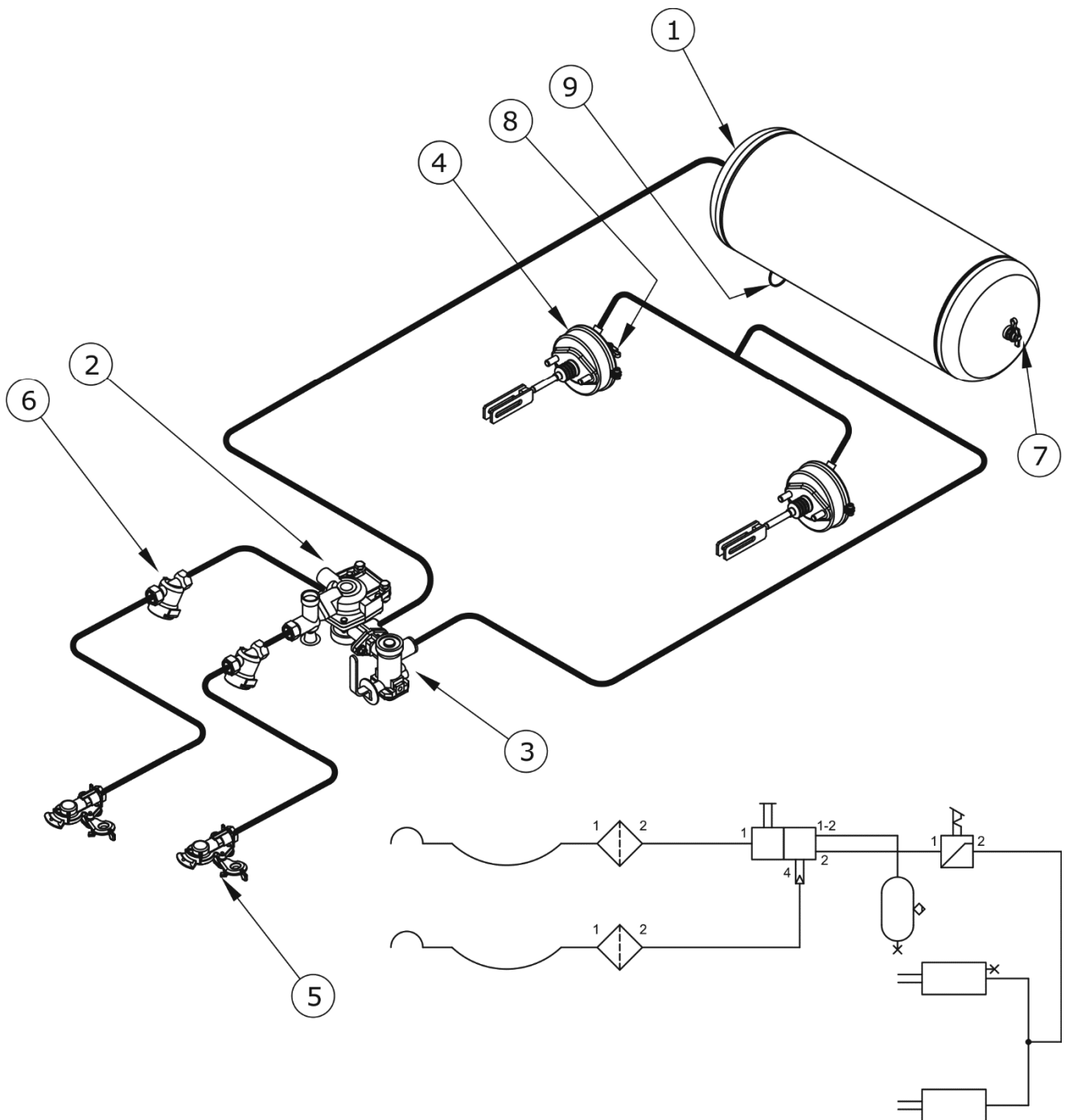
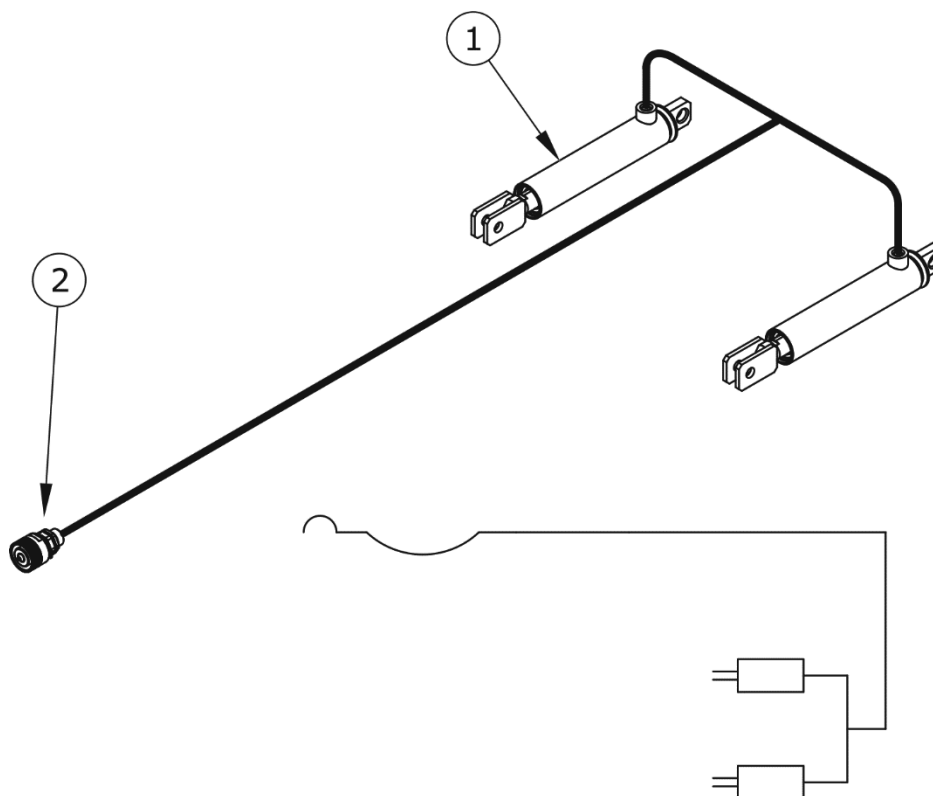

**FIGURE 3.6** Design and diagram of the double conduit pneumatic braking system.

(1) air tank, (2) control valve, (3) braking force regulator, (4) pneumatic cylinder, (5) conduit connection, (6) air filter, (7) air tank control connector, (8) pneumatic cylinder control connector, (9) drain valve

The main brake (pneumatic or hydraulic brake) is activated from the tractor driver's cab by depressing the brake pedal. The function of the control valve (2) - figure (3.5) and (3.6) is to

activate the mixer feeder's brakes simultaneously with the tractor's brakes. Furthermore, in case of an inadvertent disconnection of the conduit between the mixer feeder and the tractor, the control valve will automatically activate the mixer feeder's brakes. The valve used in the system is equipped with a circuit causing the brakes to be applied when the mixer feeder is disconnected from the tractor, compare figure (3.8). When the compressed air conduit is connected to the tractor, the device automatically applying the brakes now changes its position to allow normal brake operation.



**FIGURE 3.7** Design and diagram of hydraulic braking system

(1) hydraulic cylinder, (2) hydraulic quick coupler

Three-step braking force regulator (2)- figure (3.8) adjusts braking force depending on setting. Switching to a suitable working mode is done manually by the machine operator using the lever (4) prior to moving off. Three working positions are available: A - "no load", B - "half load" and C - "full load".

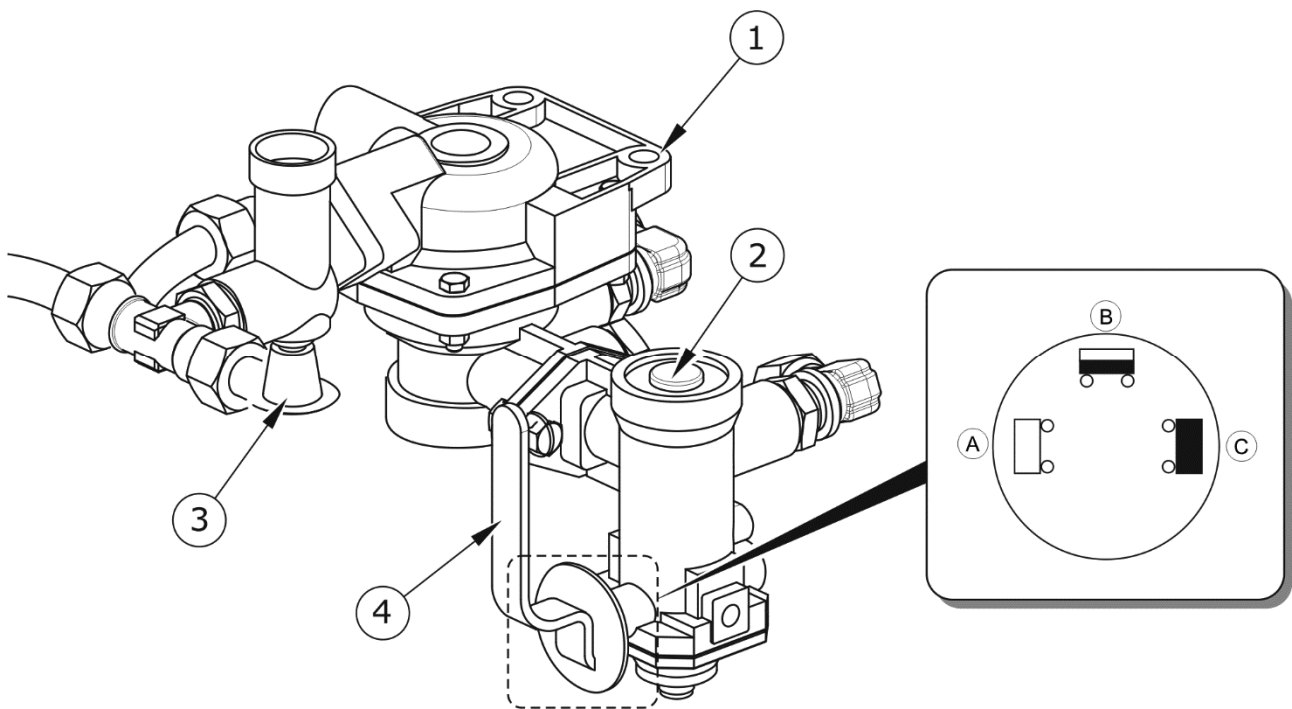
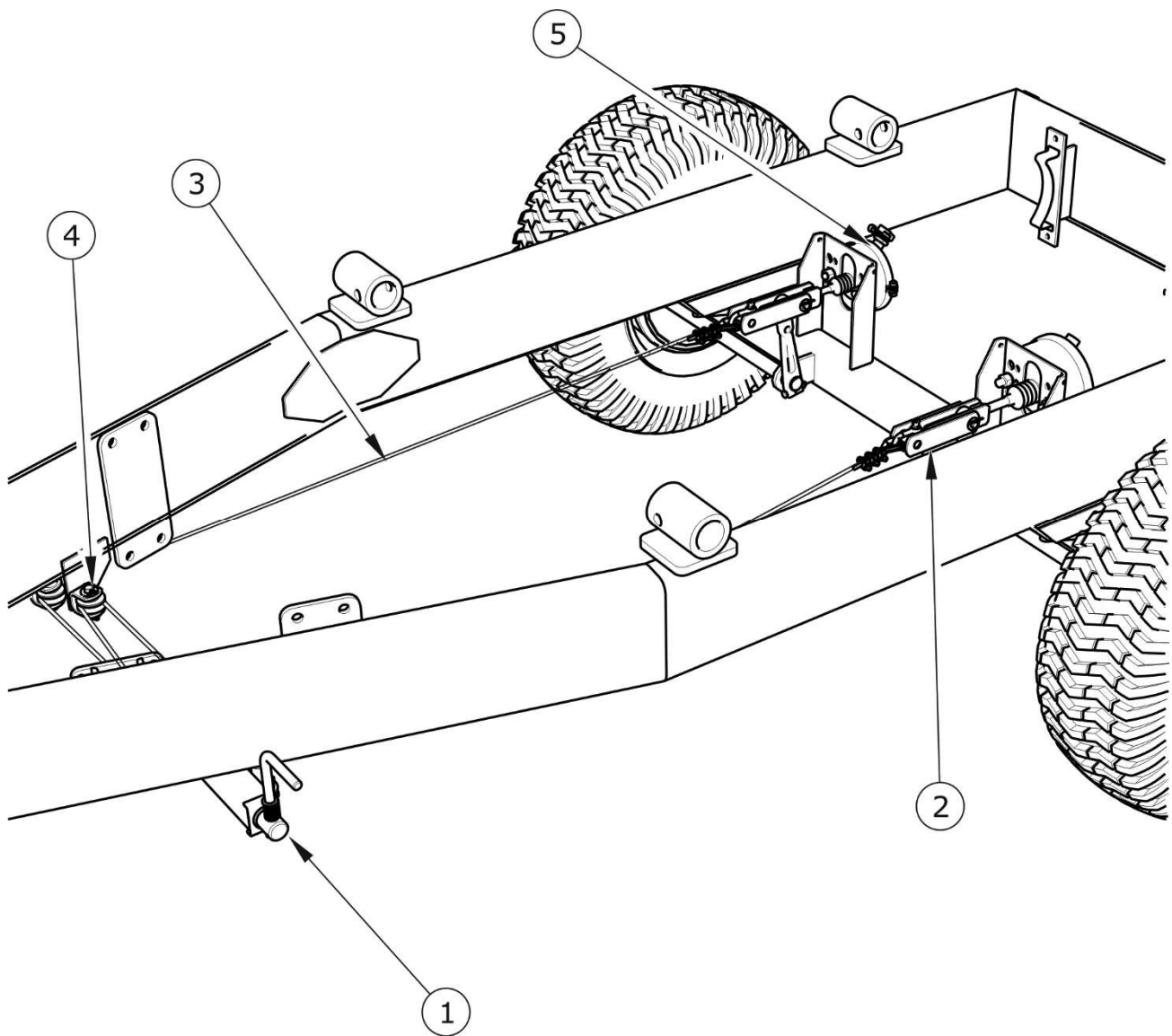

**FIGURE 3.8 Control valve and braking force regulator**

(1) control valve, (2) braking force regulator, (3) push-button for applying the mixer feeder's brakes while standing motionless, (4) regulator working position selection lever, (A) "NO LOAD" position, (B) "HALF LOAD" position, (C) "FULL LOAD" position

### 3.2.4 PARKING BRAKE

The parking brake is used for immobilising the mixer feeder while standing motionless. The design of the system is shown in figure (3.9). Brake crank mechanism (1) is welded to the left longitudinal member of the lower frame. Steel cable (3) is connected to the wheel axle's expander levers through the handbrake release (2) and the set of guide rollers (4) with crank mechanism (1). When the cable is tightened, the expander levers tilt and part the brake shoes immobilising the mixer feeder.

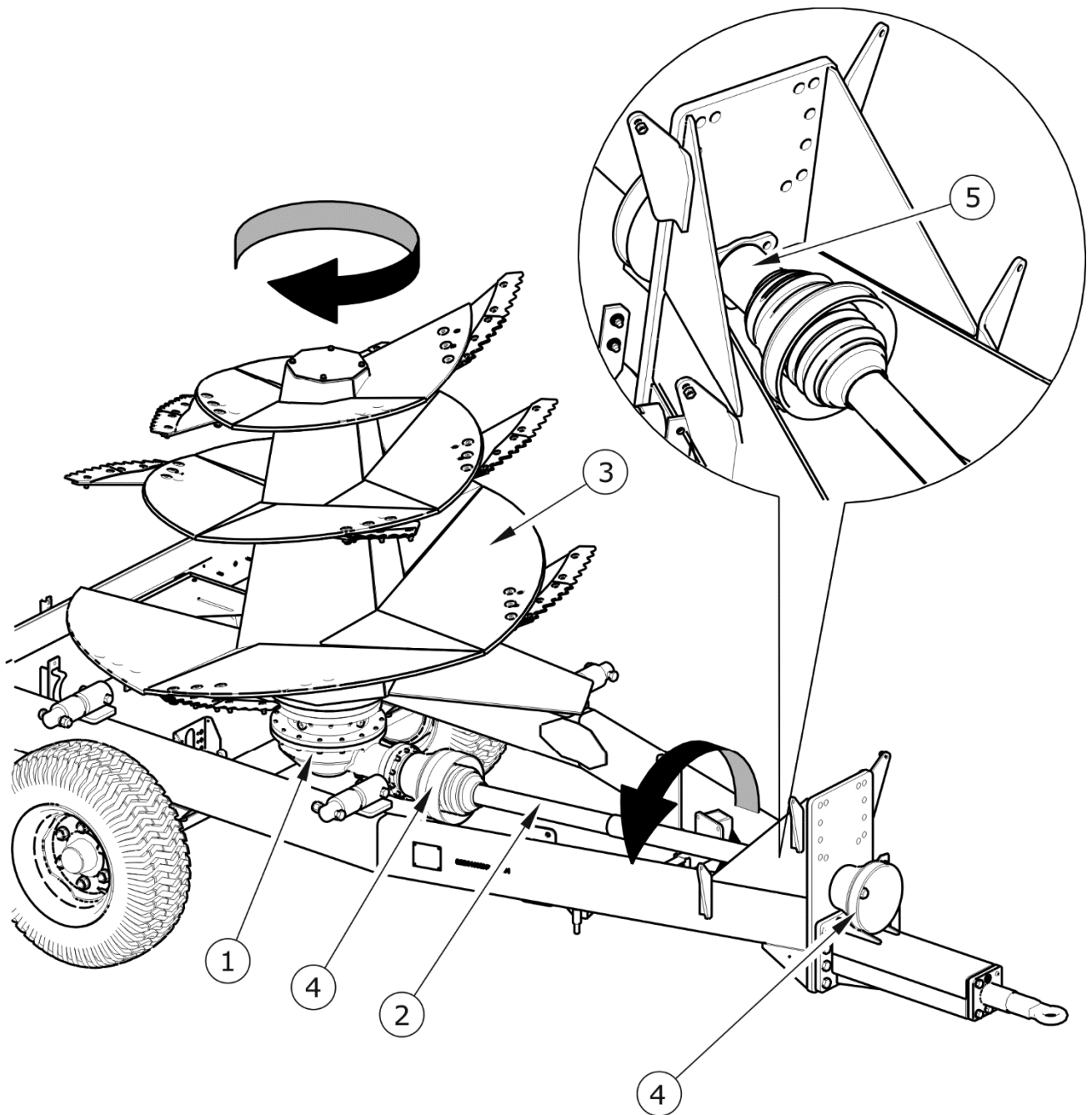

**FIGURE 3.9** Parking brake

(1) brake crank mechanism, (2) handbrake release, (3) steel cable, (4) guide roller, (5) brake cylinder

**3.2.5 DRIVE TRANSMISSION SYSTEM – STANDARD VERSION**

The standard drive system is equipped with a single planetary gear (1) – figure (3.10). The power driving the auger mixer is transmitted from the tractor through the PTO shaft connecting the mixer feeder with the tractor and the intermediate shaft (2) with friction overload clutch to the reduction planetary gear (1). The auger mixer (3) is mounted on the gear output shaft.



**FIGURE 3.10** Drive transmission system – standard version

(1) planetary gear, (2) intermediate drive shaft, (3) auger mixer, (4) shaft terminal cover, (5) shaft connector

**3.2.6 DRIVE TRANSMISSION SYSTEM – OPTIONAL VERSION**

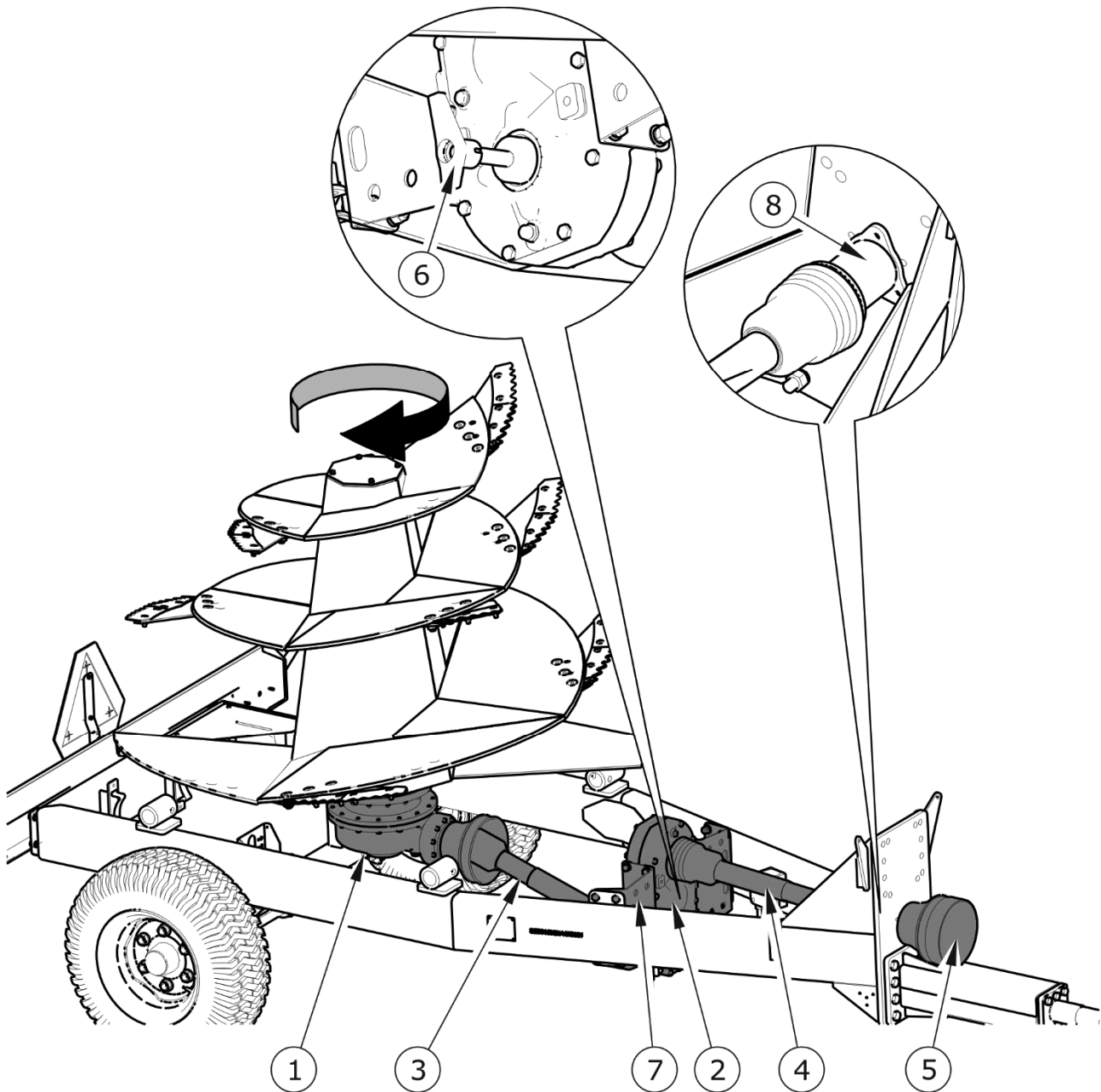

**FIGURE 3.11 Drive transmission system – optional version**

*(1) planetary gear, (2) two-speed reduction gear, (3) intermediate drive shaft, (4) intermediate drive shaft, (5) shaft shield, (6) speed change lever, (7) gear bracket, (8) shaft connector*

The optional drive transmission system is available in the configuration with two gears. The power driving the auger mixer is transmitted from the tractor through the PTO shaft connecting the mixer feeder with the tractor, two intermediate shafts (3) and (4) – figure (3.11) and two-speed reduction gear (2) and planetary gear (1). The planetary gear (1)



mounted at the tank bottom transmits power to the auger mixer. The auger mixer speed can be reduced or increased by means of the reduction gear (2) with built-in speed change lever (6).

**TIP**

The auger mixer is the same in the two drive system versions.

The maximum speed of PTO shaft in the drive system (regardless of the version) is 540 rpm.

### 3.2.7 TRANSMISSION LUBRICATION SYSTEM

The transmission lubrication system is shown in figure (3.12). The gear oil tank (1) is installed in the rear part of the mixer feeder tank, which is located above the highest point of the gear. Conduit (3) connects the tank with the gear. Oil flows down to the reduction gear and supplements missing oil.

**TIP**

Capacity of the transmission lubrication system is approximately 16 litres (for both types of reducers).

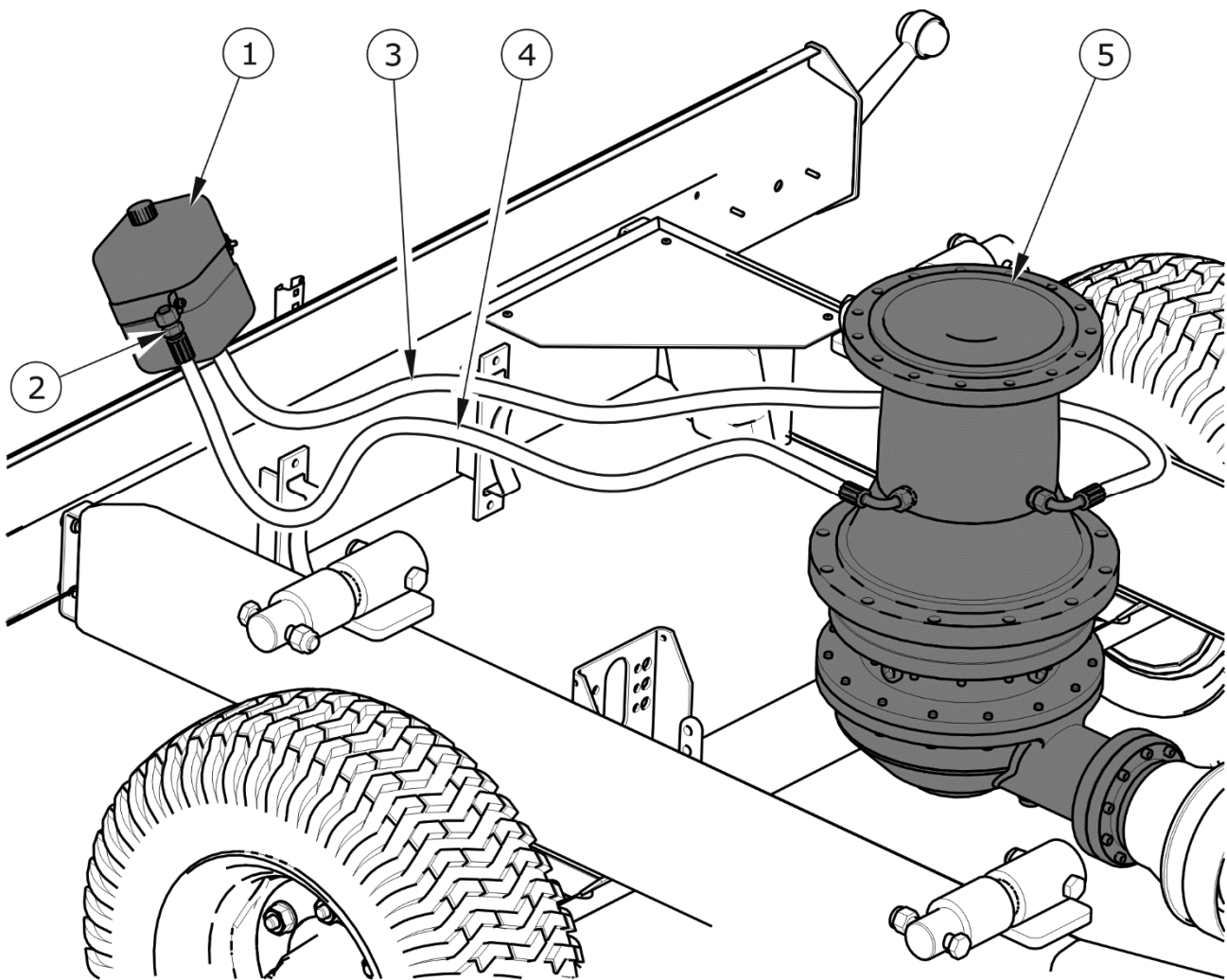
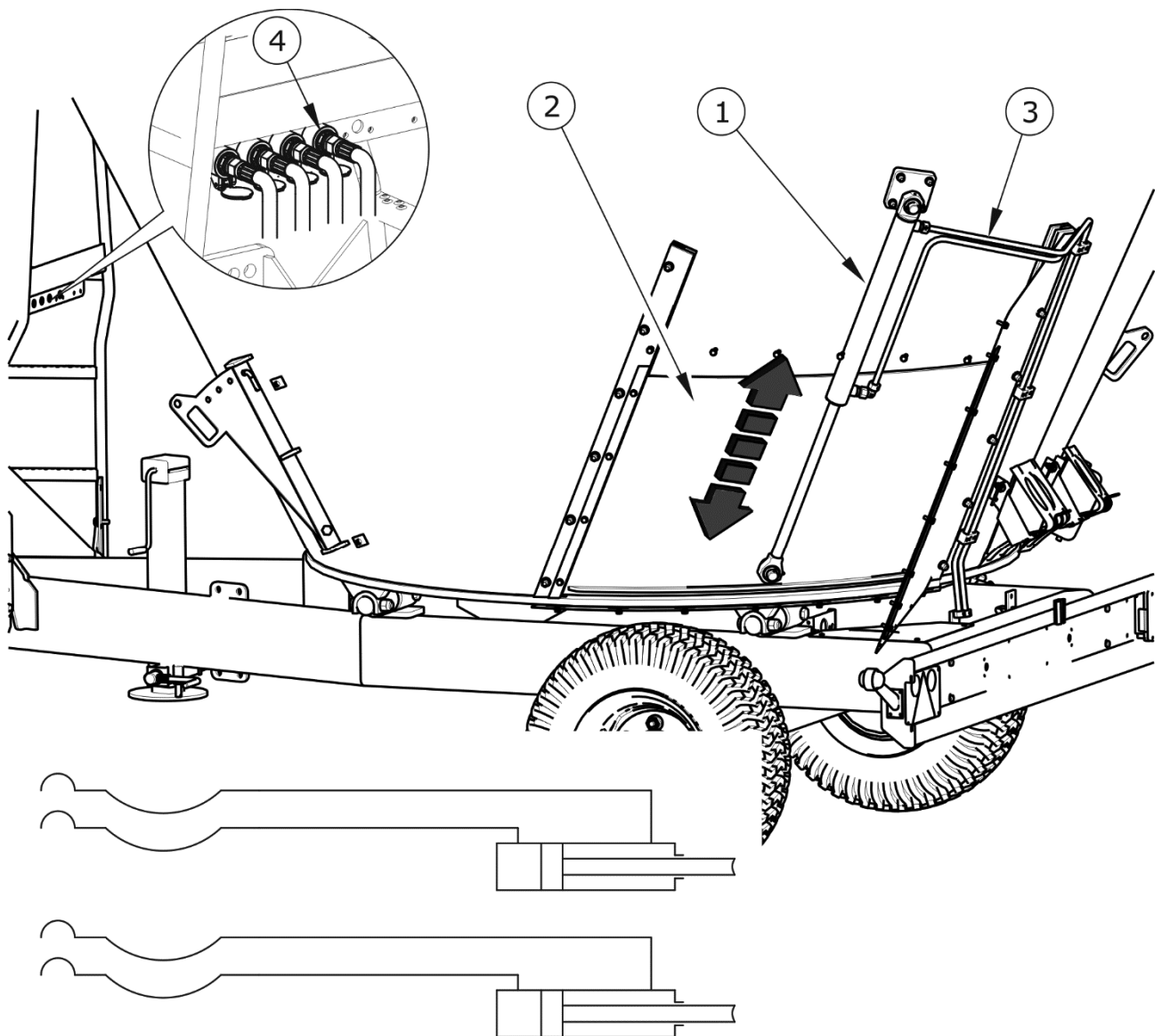

**FIGURE 3.12 Transmission lubrication system**

*(1) oil tank, (2) plug, (3) supply conduit, (4) bleed conduit, (5) planetary gear*

### **3.2.8 HYDRAULIC SYSTEM OF THE SLIDE GATES**

The mixer feeder is equipped with two slide gates (2) – figure (3.13) for feed batching. The slide gates are located on both sides of the tank and are activated by hydraulic cylinders (1). The control system is supplied from the external hydraulic system of the tractor. The slide gates are controlled independently. This solution makes it possible to batch feed on the left side and the right side of the mixer feeder. Feed batching speed depends on the auger mixer speed and the degree of opening of the slide gates. While parking the mixer feeder, the quick coupler terminals should be protected against contamination by placing them in special sockets (4). Quick coupler sockets are attached to the mixer feeder's platform. Design and diagram of the hydraulic system is shown in figure (3.13).

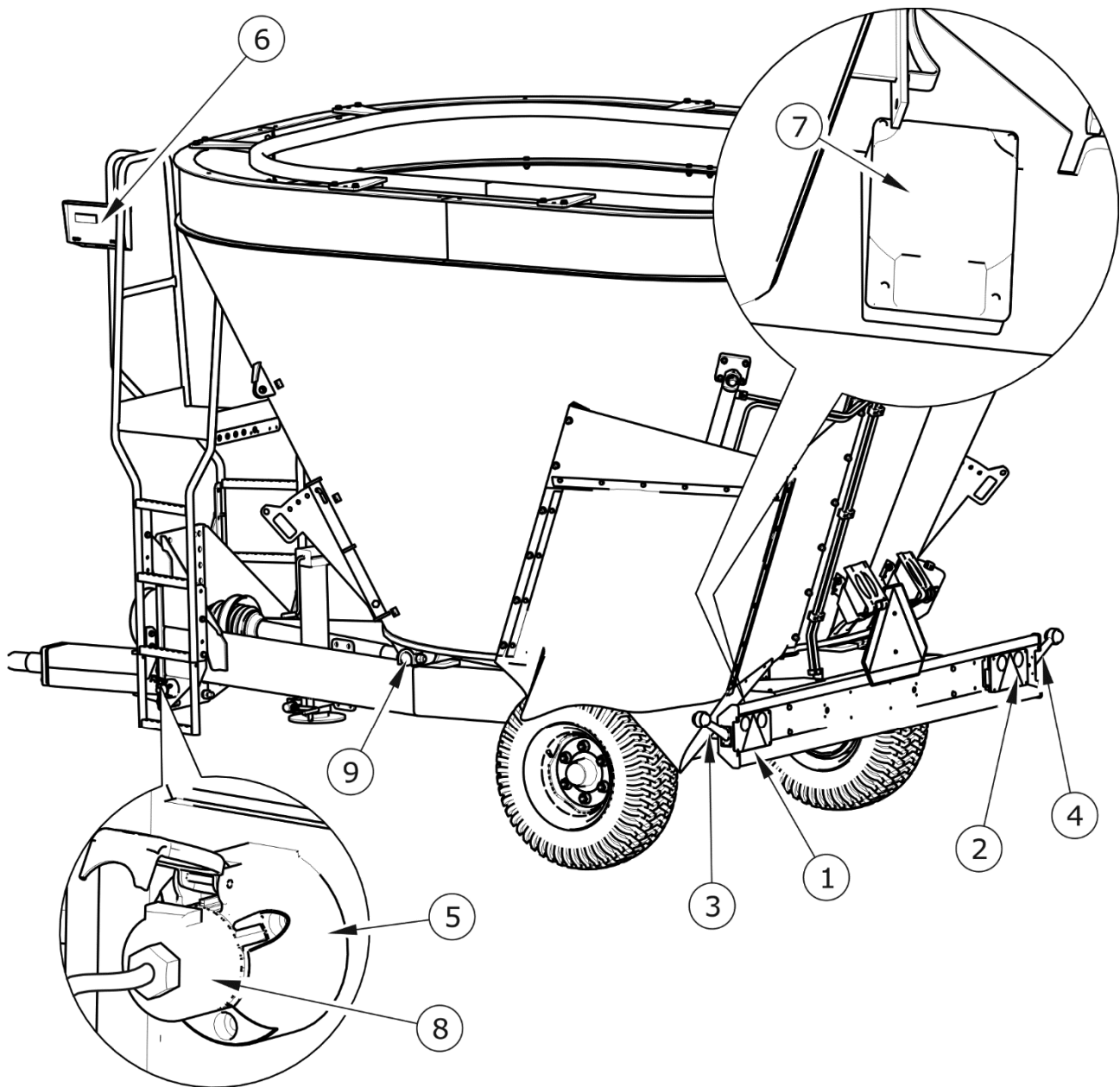

**FIGURE 3.13** Diagram and design of the slide gates' hydraulic system

(1) hydraulic cylinder, (2) slide gate, (3) hydraulic conduits, (4) quick couplers and sockets

### 3.2.9 ELECTRICAL SYSTEM

The mixer feeder's electrical system is designed for supply from direct current source of 12 V. Connection of the mixer feeder's electrical system with the tractor should be made using the connection lead (8) delivered with the machine. Clearance lights (3) and (4) – figure (3.14) and lamp assemblies (1) and (2) are mounted on the rear lights support beam. Connection socket (5) is located in the front part of the mixer feeder and bolted to the left angle brace of the drawbar's front plate.



**FIGURE 3.14 Arrangement of electrical system components**

(1) rear lamp assembly, left side, (2) rear lamp assembly, right side, (3) left clearance lamp, (4) right clearance lamp, (5) electric socket, (6) scales display, (7) connection box, (8) connection lead, (9) load cells

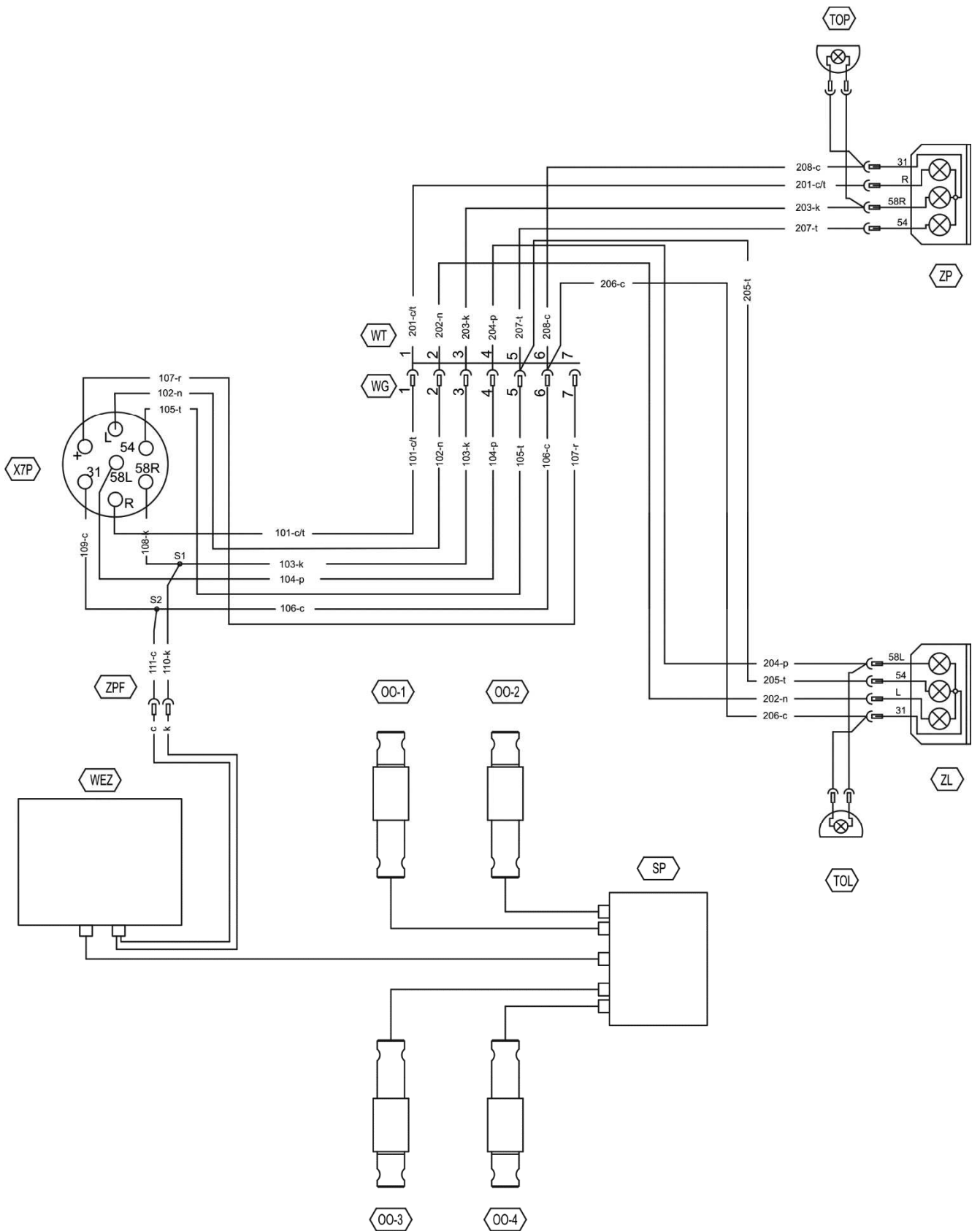

FIGURE 3.15 Electrical system diagram

**TABLE 3.2 List of electrical system diagram markings**

<b>SYMBOL</b>	<b>FUNCTION</b>
ZP	Rear right lamp assembly
ZL	Rear left lamp assembly
X7P	Seven pin connection socket
TOP	Rear right clearance lamp
TOL	Rear left clearance lamp
OO-1...OO-4	Load cells
WEZ	Scales display
SP	Connection box

**TABLE 3.3 Lead colour marking**

<b>MARKING</b>	<b>LEAD COLOUR</b>	<b>MARKING</b>	<b>LEAD COLOUR</b>
B	White	O	Brown
C	Black	P	Orange
F	Violet	R	Pink
K	Red	S	Grey
L	Lazurite	T	Green
N	Blue	Z	Yellow

The mixer feeder tank is mounted on the lower frame by means of four load cells (9). The load cells, connection box (7) and display (6) form the mixer feeder load measuring system. Load cells are connected through connection box with the electronic display, which analyses electric signals originating from weighing points and calculates the load weight. The measuring system can work only when the tractor's parking lights or dipped headlights are switched on. Electrical system diagram is shown in figure (3.14).

Lead colours and symbols are described in tables (3.2) and (3.3)

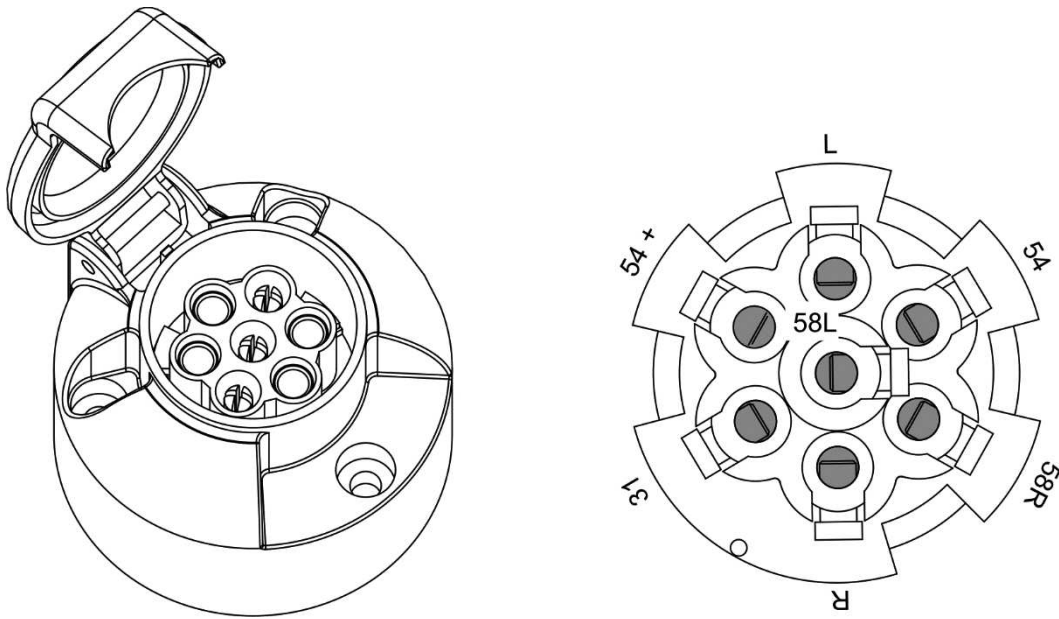

**FIGURE 3.16** Connection socket

**TABLE 3.4** Socket connection markings

MARKING	FUNCTION
31	Weight
+	Power supply +12V (not used)
L	Left indicator
54	STOP light
58L	Rear left parking light
58R	Rear right parking light
R	Right indicator



### ATTENTION

Electric welding of the mixer feeder components may damage the load cells. Therefore, remove these elements before commencing this type of work.





***SECTION***

**4**

---

**CORRECT USE**

## 4.1 PREPARING THE MIXER FEEDER FOR WORK

### 4.1.1 PRELIMINARY INFORMATION

The mixer feeder is supplied to the user completely assembled and does not require additional assembling of the machine sub-assemblies. The manufacturer guarantees that the machine is fully operational and has been checked according to quality control procedures and is ready for use. This does not release the user from an obligation to check the machine's condition prior to purchasing and before first use.

### 4.1.2 HAND-OVER AND INSPECTION OF THE MACHINE AFTER DELIVERY

After delivery of the machine to the buyer, the user is obliged to check technical condition of the mixer feeder (one-time inspection). While buying the machine, the user must be informed by the seller about the method of use of the mixer feeder, risks resulting from the use for purposes other than intended, the method of the machine hitching and the principles of the machine construction and design. Detailed information concerning the machine hand-over are included in the *WARRANTY BOOK*.

#### Checking the mixer feeder after delivery

- ➔ Check completeness of the mixer feeder according to order.
- ➔ Check components of the electrical system and the scales.
- ➔ Check technical condition of safety guards.
- ➔ Check condition of paint coatings, traces of corrosion or mechanical damage (crushing, piercing, bending or breaking of elements).
- ➔ Check technical condition of PTO shafts and their shields as well as completeness of these elements.
- ➔ Check technical condition and mounting of the knives on the auger and the disintegrating knives installed in the tank.
- ➔ Check air pressure in tyres and check correct tightening of wheel nuts.
- ➔ Check technical condition of drawbar, drawbar eye and if correctly installed.
- ➔ Ensure that the attached PTO shaft may be connected to the tractor, check rotation direction of tractor PTO.

Notify the seller about any non-conformities resulting from damage during transport, wrong machine configuration, etc.



### ATTENTION

The seller is obliged to conduct the first start up of the mixer feeder in the presence of the user.

The user trained by the seller is not released from the obligation to read this operator's manual carefully.

### 4.1.3 PREPARING THE MIXER FEEDER FOR THE FIRST USE, TEST RUN OF THE MIXER FEEDER



### TIP

Operating activities: hitching to/unhitching from tractor, adjustment of clutch supply pressure etc. are described in detail in further sections of the Operator's Manual.

#### Preparing for the test run

- ➔ Carefully read this *OPERATOR'S MANUAL* and the operator's manual of the PTO shaft and adhere to the recommendations contained in these documents.
- ➔ Visually inspect the mixer feeder according to the guidelines presented in section *PREPARING THE MIXER FEEDER FOR NORMAL USE*.
- ➔ Adapt the height of the mixer feeder's drawbar to the tractor hitch.
- ➔ Hitch the mixer feeder to tractor. Make certain that the PTO rotation direction is correct. Immobilise the tractor and the mixer feeder with parking brake.
- ➔ Check oil level in the planetary gear (and in the two-speed transmission, if installed).
- ➔ Check oil level in the expansion tank of the transmission lubrication system.
- ➔ Adjust the height and position of the scales display.

#### Test start

- ➔ Make sure there are no objects or living animals in the mixer feeder tank.

- ➔ Open the dispensing windows. Turn the auger clockwise to confirm that it works smoothly, without jamming and there is no doubt as to its proper operation in future. Close the dispensing windows.
- ➔ Start the PTO drive. Stop the PTO drive after 3 minutes.
- ➔ Turn on all lights in the mixer feeder in succession, check operation of weighing system.
- ➔ Release parking brake. When moving off check if the main brakes operate correctly.

If during test run worrying symptoms occur such as:

- noise and abnormal sounds caused by rubbing of moving elements against the mixer feeder structure,
- hydraulic oil leak,
- pressure drop in braking system,
- incorrect hydraulic system operation
- blocking of pneumatic pistons,
- other suspected faults,

immediately disengage the tractor's PTO drive and turn off the tractor engine. If a fault cannot be rectified or the repair could void the guarantee, please contact retailer for additional clarifications or to make a repair.

#### **4.1.4 PREPARING THE MIXER FEEDER FOR NORMAL USE**

##### **Scope of inspection activities**

- ➔ Visually inspect if the tyres are properly inflated. In case of doubt, carefully check tyre pressure.
- ➔ Check level of transmission lubricating oil in the expansion tank.
- ➔ Check technical condition of drawbar eye.
- ➔ Check operation of the electrical system.

- ➔ Check technical condition and completeness of safety guards.
- ➔ Check the condition of cutting blades and disintegrating blades and their proper mounting.
- ➔ Check technical condition of PTO shaft, its shields and securing chains.

The above-mentioned activities should be performed before each start of the mixer feeder. Detailed information on other activities, inspection intervals and related procedures are included in section 5 *MAINTENANCE*.

## **DANGER**



Careless and incorrect use and operation of the mixer feeder and non-compliance with the recommendations given in this Operator's Manual is dangerous to your health.

The mixer feeder must never be used by persons who are not authorised to drive agricultural tractors, including children and people under the influence of alcohol or other drugs.

Non-compliance with the safety rules of this Operator's Manual can be dangerous to the health and life of the operator and others.

## **4.2 HITCHING AND UNHITCHING THE MIXER FEEDER**

The mixer feeder may be hitched to the tractor only if all electrical, hydraulic and pneumatic connections and the agricultural tractor's hitch are according to the Manufacturer's requirements. In order to hitch the mixer feeder to the tractor, carry out the following actions in the following sequence.

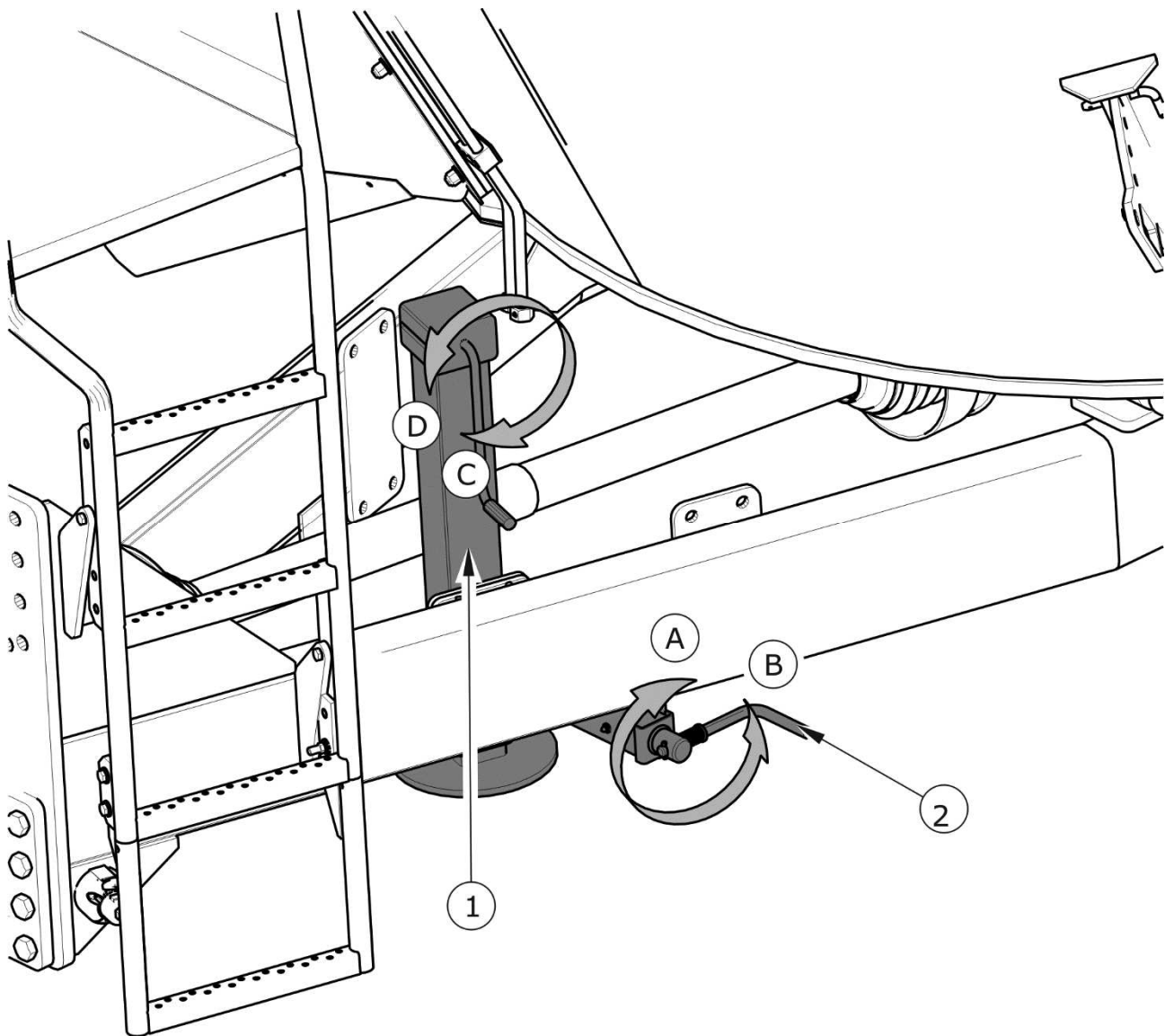

**FIGURE 4.1 Operation of support and parking brake**

(1) support, (2) brake crank mechanism, (A) engage the parking brake, (B) release the parking brake, (C) lower the support foot, (D) raise the support foot

### Hitching to tractor

- Position agricultural tractor directly in front of the mixer feeder's drawbar eye.
- Immobilise the mixer feeder with parking brake.
  - ⇒ Pull brake mechanism in (A) direction until resistance is felt - figure (4.1) - clockwise.
- Turn the crank in (C) direction, lower the support foot and position the drawbar eye at the correct height.

- ➔ Reverse tractor, hitch the mixer feeder to appropriate hitch on tractor, check hitch lock protecting machine against accidental unhitching.
  - ⇒ If the agricultural tractor is equipped with an automatic coupler, ensure that the hitching operation is completed and that drawbar eye is secured.
- ➔ Turn off tractor engine. Ensure that unauthorised persons do not have access to the tractor cab.
- ➔ Connect pneumatic system conduits (applies to double conduit systems):
  - ⇒ Connect pneumatic conduit marked yellow with yellow socket in tractor.
  - ⇒ Connect pneumatic conduit marked red with red socket in tractor.
- ➔ Connect pneumatic system conduits (applies to single conduit pneumatic system):
  - ⇒ Connect pneumatic conduit marked black with black socket in tractor.
- ➔ Connect hydraulic braking system conduits (applies to the mixer feeder version with hydraulic braking system).
- ➔ Connect conduits of the hydraulic control system of the slide gates to the tractor.
- ➔ Connect electrical leads to the tractor.
- ➔ Connect PTO shaft and secure its shields.
- ➔ Raise the support foot using the crank.
- ➔ Check and, if necessary, protect electrical leads and hydraulic and pneumatic conduits against rubbing or other mechanical damage.
- ➔ Immediately before moving, remove the chocks from under the mixer feeder's wheels and place them in the appropriate holders on the rear wall of the tank.

**ATTENTION**

Do NOT travel on public roads with machine which has unreliable lighting system or signalling system.

Do NOT use out of order mixer feeder.

When turning, the connection conduits must hang loosely and not become tangled with moving elements of the mixer feeder and tractor.

During travel and operation of the mixer feeder, the support foot must be raised.

If the agricultural tractor is equipped with an automatic coupler, ensure that the hitching operation is completed and that drawbar eye is secured.

Pneumatic brake systems are equipped with connectors, whose safety caps are made from coloured plastic. The colours of these elements correspond to the colours of the connection sockets in the tractor (yellow, red or black). Hydraulic brake supply conduit plug should be connected to the tractor hydraulic brake socket.

When connecting the pneumatic brake system conduits, it is very important to ensure the correct sequence of conduit connection. Once the conduits are connected, the braking system will switch to normal mode of operation (disconnection or interruption of the conduits causes the mixer feeder's braking system control valve to automatically apply brakes).

When connecting the conduits controlling the operation of slide gate rising/lowering cylinders, be careful not to make wrong connections of conduit pairs.

**DANGER**

When hitching, there must be nobody between the mixer feeder and the tractor. When hitching the machine, tractor driver must exercise caution and make sure that nobody is present in the hazard zone.

When connecting the hydraulic conduits to the tractor, make sure that the hydraulic systems of the tractor and mixer feeder are not under pressure.

Ensure sufficient visibility during hitching.

Exercise due caution during support operation - danger of severing limbs.

After completion of hitching check the security of the hitching pin.



## Unhitching

In order to unhitch the mixer feeder from the tractor carry out the following actions in the following sequence.

- ➔ Immobilise tractor with parking brake, turn off tractor engine
- ➔ Ensure that unauthorised persons do not have access to the tractor cab.
- ➔ Place chocks under the mixer feeder's wheels in order to prevent the machine from rolling. Immobilise the machine with parking brake.
- ➔ Turn the crank to lower the support foot.
  - ⇒ Set the drawbar eye at such a height that one may safely unlock and unhitch the mixer feeder's drawbar eye.
- ➔ Disconnect PTO shaft from tractor.
- ➔ Disconnect the slide gate hydraulic system conduits from tractor.
  - ⇒ Place quick couplers in special sockets in the rear section of the platform.
- ➔ Disconnect electric lead.
- ➔ Disconnect pneumatic system conduits (applies to double conduit pneumatic system).
  - ⇒ Disconnect pneumatic conduit marked red.
  - ⇒ Disconnect pneumatic conduit marked yellow.
- ➔ Disconnect pneumatic system conduits (applies to single conduit systems):
  - ⇒ Disconnect pneumatic conduit marked black.
- ➔ Disconnect hydraulic braking system conduits (applies to the mixer feeder with hydraulic braking system).
- ➔ Unlock tractor hitch, disconnect the mixer feeder's drawbar eye from tractor hitch.

**DANGER**

Exercise caution when unhitching the mixer feeder from the tractor. Ensure good visibility. Unless it is necessary, do not go between tractor and machine.

Before disconnecting conduits and drawbar eye, close tractor cab and secure it against access by unauthorised persons. Turn off tractor engine.

Do NOT unhitch the mixer feeder if its tank is full.

## 4.3 FILLING THE TANK AND FEED PREPARATION

The tank loading should be performed using mechanical devices: loader, bale grab, fork, etc. Manual loading should be performed from platforms or other elevations. To ensure safety and ergonomic working conditions, the height of the stands for manual loading should be smaller than the height of the wall extension edge by at least 1.4 metre.

**DANGER**

When operating the PTO shaft, be especially careful and adhere to the recommendations contained in the operator's manuals of the tractor and mixer feeder.

When operating the mixer feeder, pay special attention to ensure that the cutting blades are always sharp. Operation of the mixer feeder with high auger mixer speeds is not economical. Take these remarks into account to shorten the feed disintegration time, save fuel and increase the machine life.

Before loading, hitch the mixer feeder to the tractor and position the machines on a level and stable surface. Immobilise both machines with parking brake. Adjust the position of disintegrating blades. Start the tractor's engine and PTO drive at a speed not higher than 200 – 300 rpm, turn on the tractor's parking lights and start the mixer feeder's scales. Make certain that both slide gates are closed. The operation of the scales and the display is described further in this section.

Preparation of nutritive fodder depends on numerous factors. That is why the nutrients and their amounts should be selected in a proper manner with the assistance of a fodder specialist who can specify some feed recipes. Please remember that the degree of feed disintegration depends not only on the auger mixer speed but also on the proper position of the cutting blades, degree of their wear and duration of mixing and disintegration process.

**DANGER**

During loading, nobody may be on the platform or near the tank. Operator may enter the platform when the feed charge is preliminarily disintegrated and mixed.

During PTO shaft operation, nobody may be at the place located above the top edge of the wall extensions.

During loading, the mixer feeder's drawbar may be raised under temporary load. That is why, take special care to ensure that the mixer feeder's drawbar eye is properly hitched and secured.

Protect your eyes against dust when being on the platform during auger mixer operation.

During auger mixer operation (during mixing and disintegrating), do NOT put your hands or legs or objects into the tank.

First load the feed ingredients that must be thoroughly disintegrated (straw, hay, fresh grass). During loading, use the scales in order to determine proper amount of added ingredients. Hay or straw may rotate together with the auger. Adjust the disintegrating blades in a proper manner to ensure correct mixing and cutting. Next feed ingredient may be loaded only when the first batch is properly mixed and disintegrated. The use of disintegrating blades considerably shortens the time of preparation of dry feed charge.

**ATTENTION**

The position of disintegrating blades may be adjusted only when the auger mixer drive is turned off.

Next, add heavier feed ingredients such as haylage, potatoes, sugar beet pulp, fodder beet and other ingredients. The process of mixing and disintegration must be continued until homogeneous feed is obtained.

During the last stage of feed preparation, add the lightest materials with low granularity or fluid ingredients (cereals, plant flour, feed preparations, water, etc.).

**DANGER**

While adding successive feed ingredients, pay particular attention to prevent foreign objects from entering the tank.

## ATTENTION



Do NOT exceed the maximum PTO rotation speed of 540 rpm.

Before loading, remove twine, film, net and other packing materials from pressed bales or blocks of feed ingredients.

Do NOT exceed the mixer feeder's maximum carrying capacity. If additional wall extensions (not included in the standard version) are installed, the feed amount must not exceed the tank capacity.

Some feed ingredients may considerably increase their volume when in contact with water – e.g. pressed sugar beet pulp. Pay attention not to exceed the maximum tank capacity when preparing feed.

The process of mixing and disintegration should be started at a PTO speed not higher than 200 – 300 rpm. This applies first of all to mixing of dry ingredients such as hay and straw. The auger mixer speed may be gradually increased if the feed ingredients are cut to a proper length and preliminarily mixed. Remember that the maximum PTO speed must not exceed 540 rpm.

Before loading a next feed batch, reduce the auger mixer speed again and gradually increase the speed when the feed is properly mixed and circulates smoothly inside the tank.



## TIP

Lower rotation speed (adjusted by the tractor engine rotation and/or the two-speed transmission) shortens the dry feed preparation time (cutting and proper mixing) and increases the life of the auger mixer's cutting blades.

Foreign objects in the mixed feed shorten the life of the cutting and disintegrating blades and may be harmful to the life of cattle. If all feed mixture ingredients are added at once, proper feed preparation may be hampered or impossible and the mixer feeder's drive system may be overloaded.

## 4.4 ANALYSIS OF FEED MIXTURE

Proper degree of mixing and disintegrating should be checked each time before adding a next ingredient. The mixer feeder operator should take several feed samples and visually inspect the feed mixture consistency. If individual samples are similar, the feed ingredients are properly cut and mixed. Otherwise, continue mixing before a next material batch is added.

The operator may enter the platform to control the feed preparation process. Exercise due caution when entering and descending the platform.

If the cattle feeding recipe has been prepared, record the amounts of added ingredients, the time required to prepare the feed and approximate humidity during the initial weeks of the mixer feeder operation. The comparison of the ready feed with the analysis results will make it possible to prepare high-quality nutritive fodder with proper consistency and degree of mixing in an efficient manner.



### **DANGER**

**The operator may enter the platform to control the feed preparation process. Exercise due caution when entering and descending the platform.**

**The samples for analysing the quality of mixing and disintegration of feed materials should be taken when the auger mixer drive is switched off.**

## **4.5 FEEDING**

Cattle feeding should start immediately after feed preparation. The mixer feeder is equipped with two slide gates mounted slantwisely with regard to the longitudinal plane of the tank. The slide gates make it possible to dispense feed on the left side and the right side of the machine.

To dispense feed, start the drive shaft, drive to the feeding stand and open the slide gate on the left or the right side of the mixer feeder. Degree of slide gate opening and auger mixer rotation speed as well as composition and consistency of feed mixture have a decisive influence on feed dispensing speed. Feed mixture circulating in the tank pours out onto the lower shield (3) – figure (4.2) and then to the feeders. Close the slide gate after completed feeding. At the end of feeding process, feed mixture may stick to the auger surface. To prevent it, increase PTO speed to 540 rpm in order to remove as much feed mixture as possible from the tank.

The parameters of the auger drive system are so selected that the power demand at the PTO speed of 540 rpm is the minimum to ensure proper mixing of feed ingredients. These parameters make it also possible to thoroughly empty the tank at the final stage of the

feeding process. Despite this, remains of feed may still stick to the auger mixer surface. These remains must be removed manually.

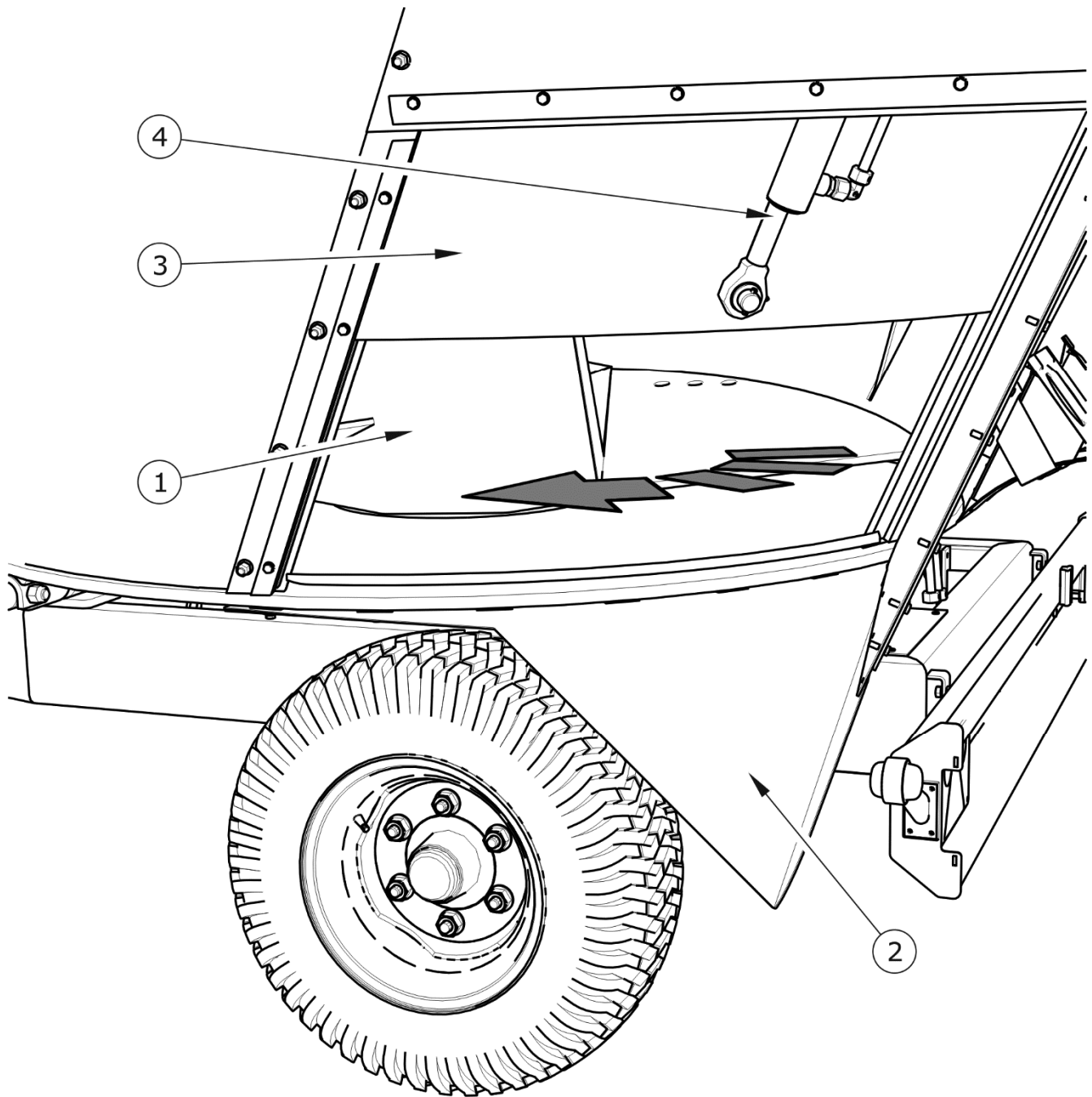

**FIGURE 4.2** Left dispensing slide gate

(1) auger mixer, (2) lower chute shield, (3) left slide gate, (4) slide gate cylinder

## 4.6 OPERATION OF THE TWO-SPEED TRANSMISSION

Depending on the feed preparation process, it may be necessary to change the auger mixer rotation speed. This can be done by changing the PTO rotation speed or changing the speed of the the two-speed transmission.

To change the speed, set the lever (2) – figure (4.3) in proper position:

- position (A) – II gear of the transmission (high auger mixer rotation speed),
- position (B) – I gear of the transmission (low auger mixer rotation speed).



### ATTENTION

The speed of the two-speed transmission can be changed only when the auger mixer is stopped and the PTO drive is switched off.

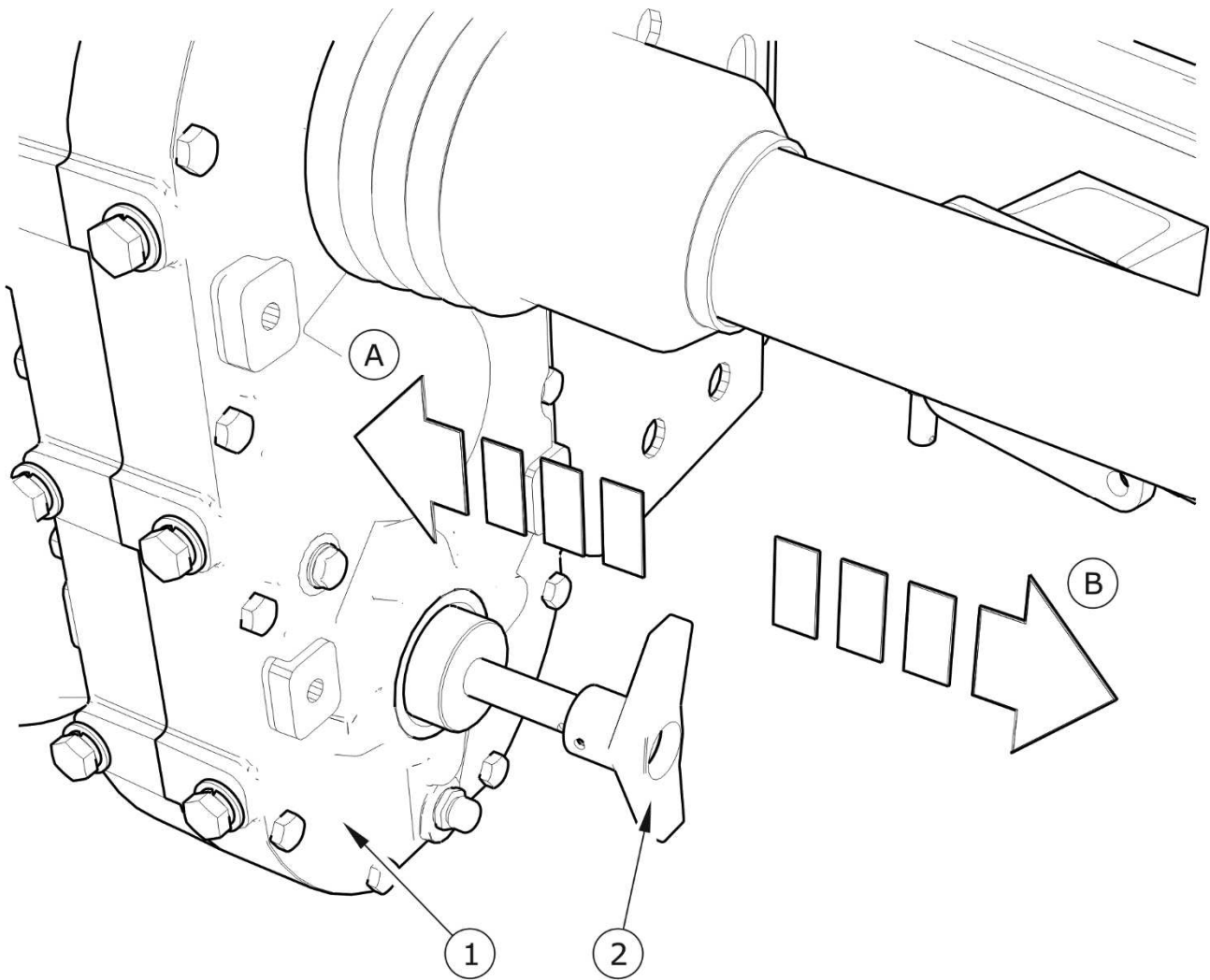

**FIGURE 4.3** Changing the speed of the auger mixer drive

*(1) two-speed gear, (2) speed change lever, (A) II speed, (B) I speed*

## 4.7 ADJUSTMENT OF COUNTER BLADES

Counter blades (1) must be slid into the tank in order to disintegrate light and dry materials - figure (4.4). Otherwise, the feed charge will rotate with the same speed as the auger. The counter blades are installed on the opposite sides of the tank using bolt and nut connection (3) and cotter pin (2).



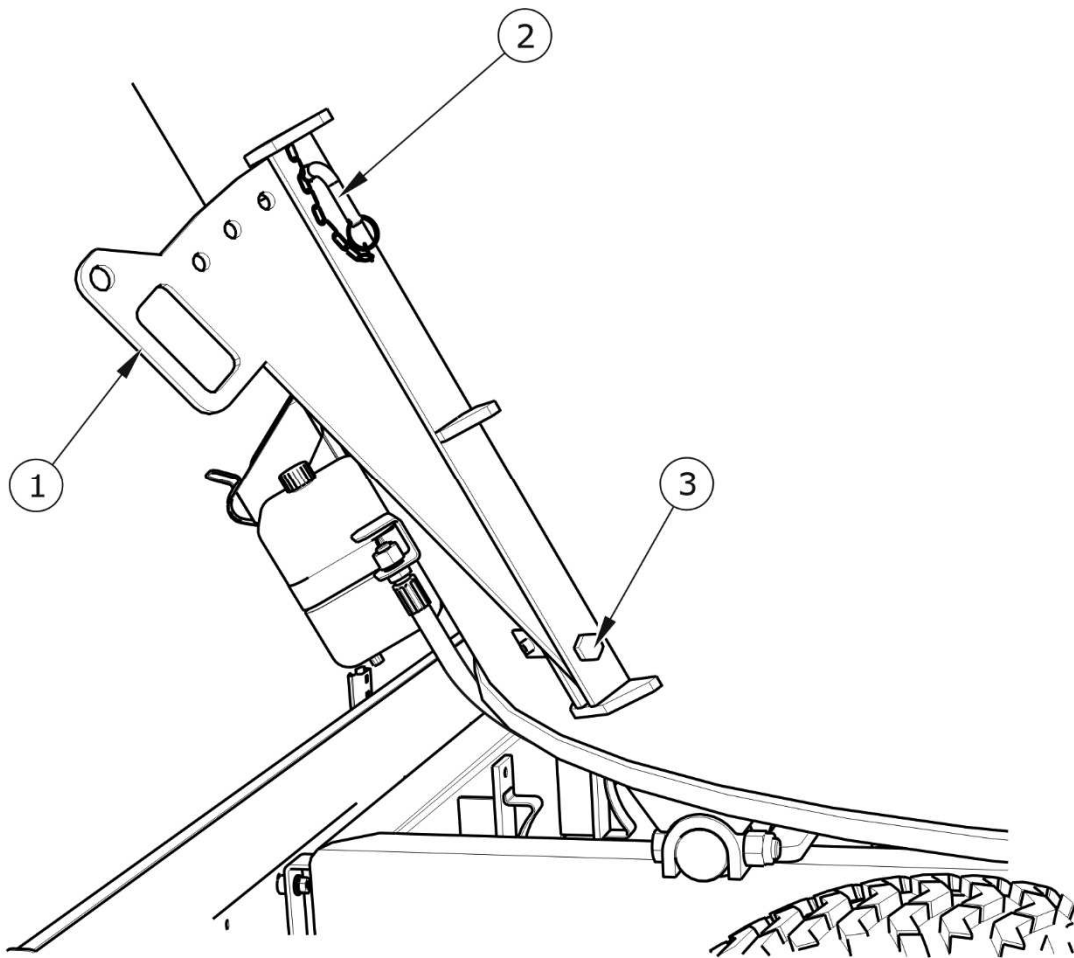

**FIGURE 4.4 Counter blade**

(1) counter blade, (2) cotter pin, (3) fixing bolt

In order to tilt the counter blade into the tank interior, unlock cotter pin (2) and slide the counter blade to a selected working position. Insert the cotter pin and repeat the same procedure for the counter blade on the opposite side of the tank. The experience in feed preparation is required to set the counter blades properly. The setting of the counter blades depends also on the material mixed in the tank - its size, humidity, etc. The counter blades do not require sharpening. The position of the counter blades may be adjusted only when the auger drive is switched off.



### **ATTENTION**

The counter blades may be adjusted only when the auger is not rotating.

## 4.8 CLEANING

Remove the remains of feed from the mixer feeder after finished feed dispensing. It is recommended to do this using a pressure washer. In order to do this:

- ➔ tilt the chutes and open the slide gates on the left side and the right side of the mixer feeder,
- ➔ turn off the tractor engine and remove key from ignition.
- ➔ immobilise mixer feeder and tractor with parking brake,
- ➔ secure tractor against access of unauthorised persons,
- ➔ clean the mixer feeder with a strong water jet and leave it to dry.

In winter, the mixer feeder drying should be performed in a room with a temperature above 0° C. Frozen water may cause damage to paint coating or machine components. Non-observance of the recommendations concerning the mixer feeder cleaning creates a real risk of growth of bacteria that may cause animal diseases.



### ATTENTION

Clean the machine thoroughly if it has not been used for more than three days.  
Remove the remains of feed from the mixer feeder each time after finished work.

## 4.9 PROPER USE AND MAINTENANCE OF TYRES

- When mounting and dismounting tyres, the mixer feeder must be immobilized by means of 2 chocks placed under the wheels.
- Repair work on the wheels or tyres should be carried out with use of appropriate tools by persons trained and entitled to do so.
- Inspect tightness of nuts after the first use of the mixer feeder, after the first travel under load and then every 6 months of use or every 25,000 km. In the event of intensive work, check the nut tightening at least every 100 km. The inspection should be repeated individually if a mixer feeder wheel has been removed from the wheel axle.

- Regularly check and maintain correct pressure in tyres according to Operator's Manual (especially if the mixer feeder is not used for a longer period).
- Pressure and tyres should be also checked after the whole day of intensive work. Please note that higher temperatures could raise tyre pressure by as much as 1 bar. At high temperatures and pressure, reduce load or speed.
- Do not release air from warm tyres to adjust the pressure or the tyres will be underinflated when temperatures return to normal.
- Protect valves using suitable caps to avoid soiling.
- Do not exceed the mixer feeder's maximum design speed.
- When machine is operated all day, check temperature of tyres.
- Adhere to 30 minutes rest for cooling tyres after driving 75 km or after 150 minutes continuous travel depending on which occurs first.
- Avoid potholes, sudden manoeuvres or high speeds when turning.

## 4.10 DRIVING ON PUBLIC ROADS

To prepare the mixer feeder for travel on public roads:

- ➔ Empty the tank.
- ➔ Attach slow moving vehicle warning plate.
- ➔ Check and possibly clean rear lamp assemblies.
- ➔ Confirm that the support is in its transport position.

When driving on public roads, adjust tractor driving speed to road conditions. Do NOT exceed permissible design speed (25 km/h) and permissible speed arising from road traffic regulations valid in a given country. When driving on public roads, comply with the road traffic regulations in force in the country in which the mixer feeder is used.

When driving on public roads, do NOT carry any load in the mixer feeder. The mixer feeder is not a machine designed for transporting loads.

Before driving on public roads, the mixer feeder must be cleaned of dirt accumulated during the machine operation, e.g. hay, straw, etc., which may cause fouling of roads.

When driving on public roads, respect the road traffic regulations, exercise caution and prudence. Listed below are the key guidelines for driving the tractor and mixer feeder combination.

- Before moving off make sure that there are no bystanders, especially children, near the mixer feeder or the tractor. Ensure that the driver has sufficient visibility.
- Vertical load borne by the mixer feeder's drawbar eye affects the steering of the agricultural tractor.
- In the event of machine or tractor malfunction, pull over on the hard shoulder avoiding any risk to other road users and position reflective warning triangle according to traffic regulations.
- While travelling on public roads the mixer feeder must be marked with the slow-moving vehicle warning sign.
- The truck tractor driver is obliged to equip the truck tractor with a certified or approved reflective warning triangle.
- When driving, comply with all road traffic regulations, indicate an intention to turn using indicator lamps, keep all road lights and indicator lights clean at all times and ensure they are in good condition. Any damaged or lost lamps or indicator lights must be immediately repaired or replaced.
- Avoid ruts, depressions, ditches or driving on roadside slopes. Driving across such obstacles could cause the mixer feeder or the tractor to suddenly tilt. Driving near ditches or canals is dangerous as there is a risk of the wheels sliding down the slope or the slope collapsing.
- Speed must be sufficiently reduced before making a turn or driving on an uneven road or a slope.
- When driving, avoid sharp turns especially on slopes.
- Please note that the braking distance of the tractor - mixer feeder combination is substantially increased at higher speeds.
- Monitor the mixer feeder's behaviour when travelling on an uneven terrain and adjust driving speed to terrain and road conditions.

***SECTION***

**5**

---

**MAINTENANCE**

## 5.1 PRELIMINARY INFORMATION

When using the mixer feeder, regular inspections of its technical condition and the performance of maintenance procedures are essential, which keep the machine in good technical condition. In connection with this the user of the mixer feeder is obliged to perform all the maintenance and adjustment procedures defined by the Manufacturer.

Repairs during the warranty period may only be performed by authorised service points.

Detailed procedures and extent of activities which the user may perform by himself are described in this section. In the event of unauthorised repairs, changes to factory settings and other actions, which are not regarded as possible for the mixer feeder operator to perform, the user shall invalidate the warranty.

## 5.2 SERVICING WHEEL AXLE

### 5.2.1 PRELIMINARY INFORMATION

Work connected with the repair, change or regeneration of axle components should be entrusted to specialist establishments, having the appropriate technology and qualifications for this type of work.

The responsibilities of the user are limited to:

- initial inspection of axle brakes,
- inspection and adjustment of slackness of axle bearings,
- mounting and dismounting wheel, inspection of wheel tightening,
- checking air pressure, evaluating technical condition of wheels and tyres.
- mechanical brakes adjustment,
- change of parking brake cable and adjustment of cable tension.

Procedures connected with:

- changing grease in axle bearings,
- changing bearings, hub seals,
- repairing wheel axle,

may be performed by specialist workshops.

### 5.2.2 INITIAL INSPECTION OF AXLE BRAKES



#### **DANGER**

**Do NOT use the mixer feeder when brake system is unreliable.**

After purchasing the mixer feeder, the user is responsible for general checking the brake system of the wheel axle.



**Initial inspection of axle brakes must be conducted:**

- after first use of the mixer feeder,
- after first travel with load.

#### **Inspection procedures**

- ➔ Hitch the mixer feeder to tractor and place chocks under its wheel.
- ➔ Engage and release in turn the main brake and then the mixer feeder's parking brake.
  - ⇒ Main brake and parking brake should be engaged and released without great resistance and severity.
- ➔ Check fixing of cylinder and return springs.
- ➔ Check cylinder movement and correct return of piston to start position.
  - ⇒ The help of a second person is required, who shall engage mixer feeder's brake.
- ➔ Check if axle elements are in place, (cotter pins in castellated nuts, expansion rings etc.).
- ➔ Check hydraulic cylinders or pneumatic cylinders for tightness.

### 5.2.3 CHECKING WHEEL AXLE BEARINGS FOR SLACKNESS

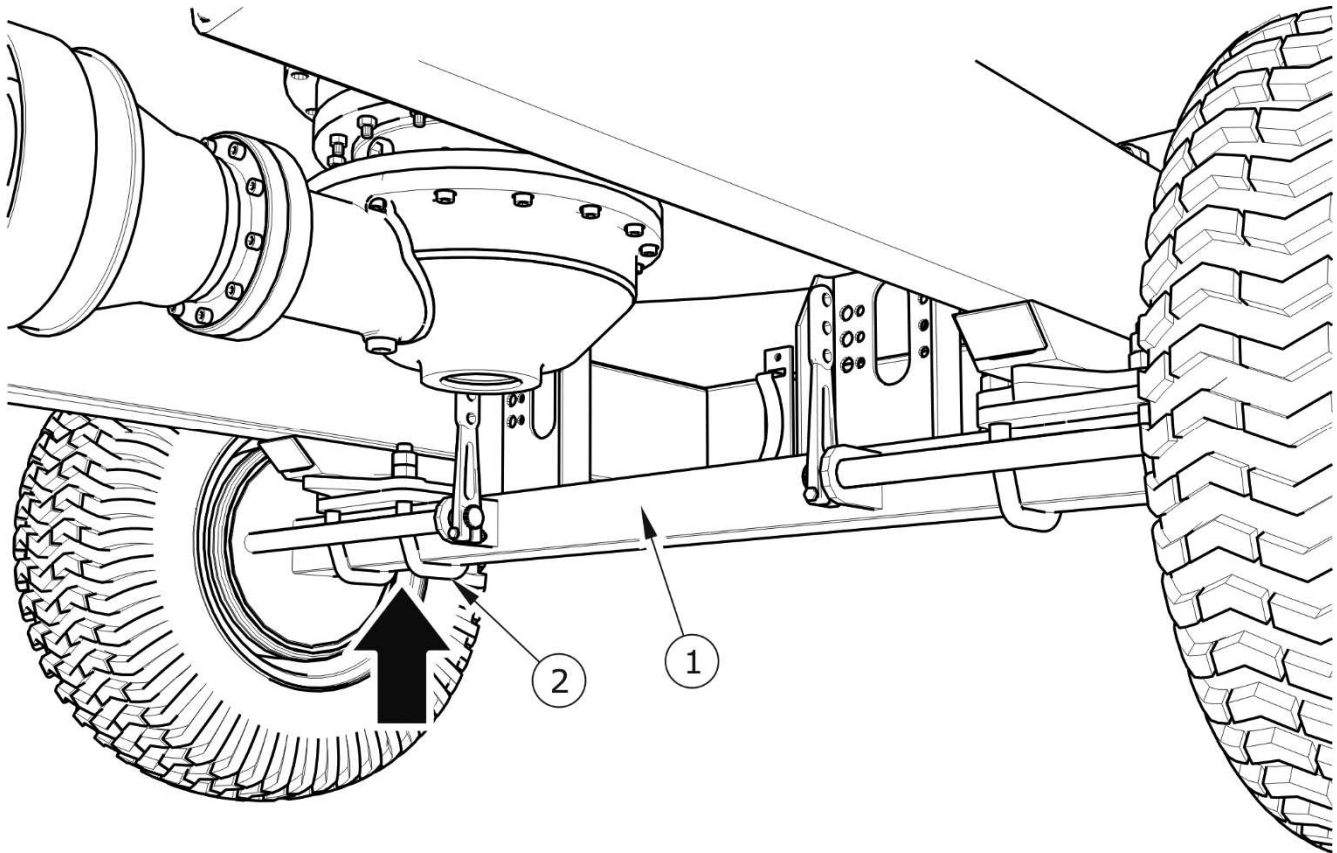

**FIGURE 5.1** Lifting jack support point

(1) wheel axle, (2) U bolt

#### Preparation procedures

- ➔ Hitch the mixer feeder to tractor, immobilize tractor with parking brake.
- ➔ Park tractor and mixer feeder on hard level ground.
  - ⇒ Tractor must be placed to drive forward.
- ➔ Place securing chocks under the mixer feeder wheel. Ensure that machine will not move during inspection.
- ➔ Raise the wheel (opposite to the side where chocks are placed).
  - ⇒ Lifting jack should be positioned in the place indicated by the arrow in figure (5.1). Lifting jack must be suited to weight of mixer feeder.



### Checking wheel axle bearings for slackness

- ➔ Turning the wheel slowly in both directions check that movement is smooth and that the wheel rotates without excessive resistance.
- ➔ Turn the wheel so that it rotates very quickly, check that the bearing does not make any unusual sounds.
- ➔ Holding the wheel above and below, try to feel any slackness.
  - ⇒ You may use a lever placed under the wheel supporting the other end of the lever on the floor.
- ➔ Lower the lifting jack, relocate the chocks to the other wheel and repeat the inspection procedure for the other wheel.



#### TIP

If hub cover is damaged or missing, contamination and dampness enter the hub, which causes significantly faster wear of bearings and hub seals.

Bearing life is dependent on working conditions of mixer feeder, loading, speed of travel and lubrication conditions.

If slackness is felt, adjust bearings. Unusual sounds coming from bearing may be symptoms of excessive wear, dirt or damage. In such an event the bearing, together with sealing ring, should be replaced with new parts, or cleaned and greased again

Check condition of hub cover, if necessary replace with a new cover. Inspection of bearing slackness may only be conducted when the mixer feeder is hitched to tractor. The machine may not be loaded.



#### Check wheel axle bearings for slackness:

- after travelling the first 1,000 km,
- before intensive use of the mixer feeder,
- every six months use or every 25,000 km.

**DANGER**

Before commencing work, the user must read the instructions for lifting jack and adhere to the manufacturer's instructions.

The lifting jack must be stably supported by the ground and so must the axle.

Ensure that the mixer feeder shall not move during inspection of axle bearing slackness.

**5.2.4 ADJUSTMENT OF AXLE BEARING SLACKNESS****Preparation procedures**

- ➔ Prepare tractor and mixer feeder for adjustment procedures according to description provided in section 5.2.3.

**Adjustment of slackness of wheel axle bearing**

- ➔ Take off hub cover (1) – figure (5.2).
- ➔ Take out cotter pin (3) securing castellated nut (2).
- ➔ Tighten castellated nut in order to eliminate slackness.
  - ⇒ Wheel should rotate with insignificant resistance.
- ➔ Undo nut (not less than 1/3 rotation) to align the nearest thread groove with the opening in wheel axle pin. Wheel should rotate without excessive resistance.
  - ⇒ Nut may not be excessively tightened. Do not apply excessive pressure because working conditions of the bearings may deteriorate.
- ➔ Secure castellated nut with cotter pin and mount the hub cap.
- ➔ Delicately tap the hub cap with rubber or wooden mallet.

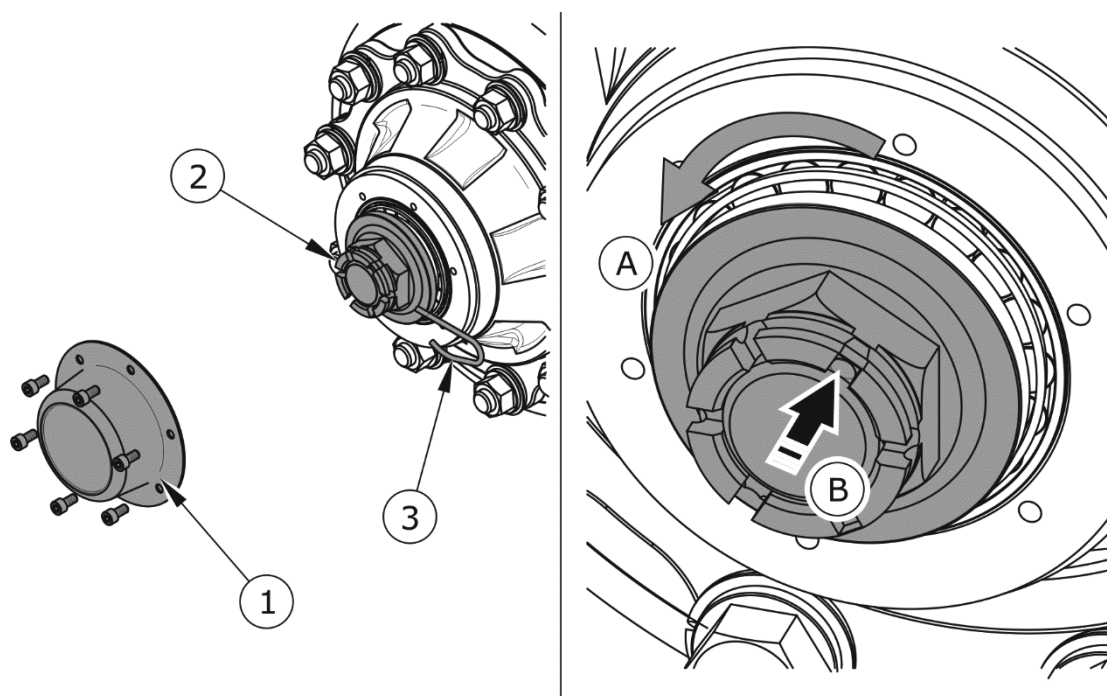

**FIGURE 5.2 Adjusting half axle bearings**

(1) hub cover, (2) castellated nut, (3) cotter pin

The wheel should turn smoothly without jamming and detectable resistance. Adjustment of bearing slackness may only be conducted when the mixer feeder is hitched to tractor and its tank is empty.



**TIP**

If the wheel is dismantled, bearing slackness is easy to check and adjust.

### 5.2.5 MOUNTING AND DISMOUNTING WHEEL, INSPECTION OF WHEEL NUT TIGHTENING

#### Dismounting wheel

- ➔ Place chocks under the wheel that will not be dismantled.
- ➔ Ensure that the mixer feeder is properly secured and shall not move during wheel dismantling.
- ➔ Loosen wheel nuts according to sequence given in figure (5.3).

- ➔ Place lifting jack and lift the mixer feeder.
- ➔ Dismount wheel.

### Wheel mounting

- ➔ Clean axle pins and nuts of contamination.
  - ⇒ Do not grease thread of nuts and pins.
- ➔ Check condition of pins and nuts, if necessary replace them.
- ➔ Place wheel on hub, tighten nuts so that wheel rim tightly fits the hub.
- ➔ Lower the mixer feeder, tighten nuts according to recommended torque and given sequence.

### Tightening nuts

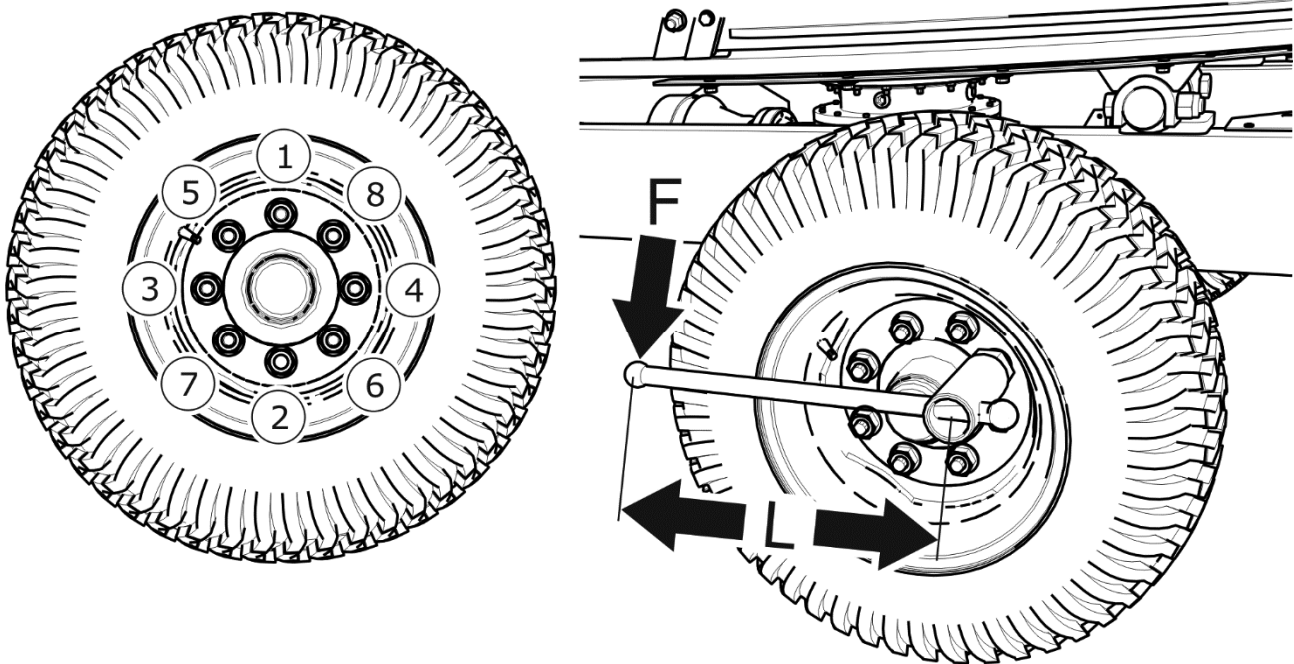

**FIGURE 5.3** Sequence of nut tightening

(1) - (6) sequence of nut tightening, (L) spanner length, (F) user weight

**TIP**

Wheel nuts should be tightened using the torque of 270 Nm - M18x1.5 nuts.

Nuts should be tightened gradually diagonally, (in several stages, until obtaining the required tightening torque) using a torque spanner. If a torque spanner is not available, one may use an ordinary spanner. The arm of the spanner (L), figure (5.3), should be selected according to the weight of the person (F) tightening the nut. Remember that this method of tightening is not as accurate as the use of a torque spanner.

**Checking wheel tightening:**

- after first use of the mixer feeder,
- after first travel with load,
- after travelling the first 1,000 km,
- every six months use or every 25,000 km.

In the event of intensive work checking the nut tightening should be done at least every 100 kilometres. The above actions should be repeated individually if a wheel has been removed from the wheel axle.

**TABLE 5.1 Spanner arm**

<b>WHEEL TIGHTENING TORQUE</b>	<b>BODY WEIGHT (F)</b>	<b>ARM LENGTH (L)</b>
<b>[Nm]</b>	<b>[kg]</b>	<b>[m]</b>
270	90	0.30
	77	0.35
	67	0.40
	60	0.45

**ATTENTION**

Wheel nuts may not be tightened with impact wrench because of danger of exceeding permissible tightening torque, the consequence of which may be breaking the thread connection or breaking off the hub pin.

The greatest precision is achieved using a torque spanner. Before commencing work, ensure that correct tightening torque value is set.

**5.2.6 CHECKING AIR PRESSURE IN TYRES, EVALUATING TECHNICAL CONDITION OF TYRES AND STEEL WHEELS**

Tyre pressure should be checked each time after changing spare wheel and not less than every month. In the event of intensive use, air pressure in tyres should be checked more frequently. During this time the mixer feeder must be unloaded. Checking should be done before travelling when tyres are not heated, or after an extended period of parking.

**TIP**

Tyre pressure values are specified in information decal, placed on wheel or on the frame above machine wheel.

**DANGER**

Damaged tyres or wheels may be the cause of a serious accident.

While checking pressure pay attention to technical condition of wheels and tyres. Look carefully at tyre sides and check the condition of tread.

In case of mechanical damage consult the nearest tyre service and check whether the tyre defect requires tyre replacement.

Wheels should be inspected with regard to distortion, breaking of material, breaking of welds, corrosion, especially in the area of welds and contact with tyre.

Technical condition and appropriate maintenance significantly extends the life of these components and ensures appropriate level of safety to mixer feeder users.



#### Checking air pressure in tyres and visual inspection of steel wheels:

- every 1 month of use,
- every week during intensive work,
- if needed.

### 5.2.7 ADJUSTMENT OF MECHANICAL BRAKES

During mixer feeder operation drum brake linings are subjected to wear. Piston stroke extends; after exceeding the limit value, the braking force declines.

Adjustment must be made when:

- piston rod stroke amounts to  $2/3$  of maximum stroke,
- expansion levers are not set in parallel to each other during braking,
- repairs are made to braking system.

The mixer feeder's wheels must brake simultaneously. Brakes adjustment involves changing the position of the expander arm (1) – figure (5.4), in relation to expander shaft (2).

#### Required maintenance actions

- ➔ Dismantle the pin fixing the cylinder fork (3) to the expander lever.
- ➔ Mark position of expander arm (1) with regard to the shaft (2).
- ➔ Dismantle arm and set it in the appropriate position.
  - ⇒ in direction (A), if braking is too early,
  - ⇒ in direction (B), if braking is too late.
- ➔ Repeat the process for the second arm.
- ➔ Replace the pin fixing the cylinder fork.

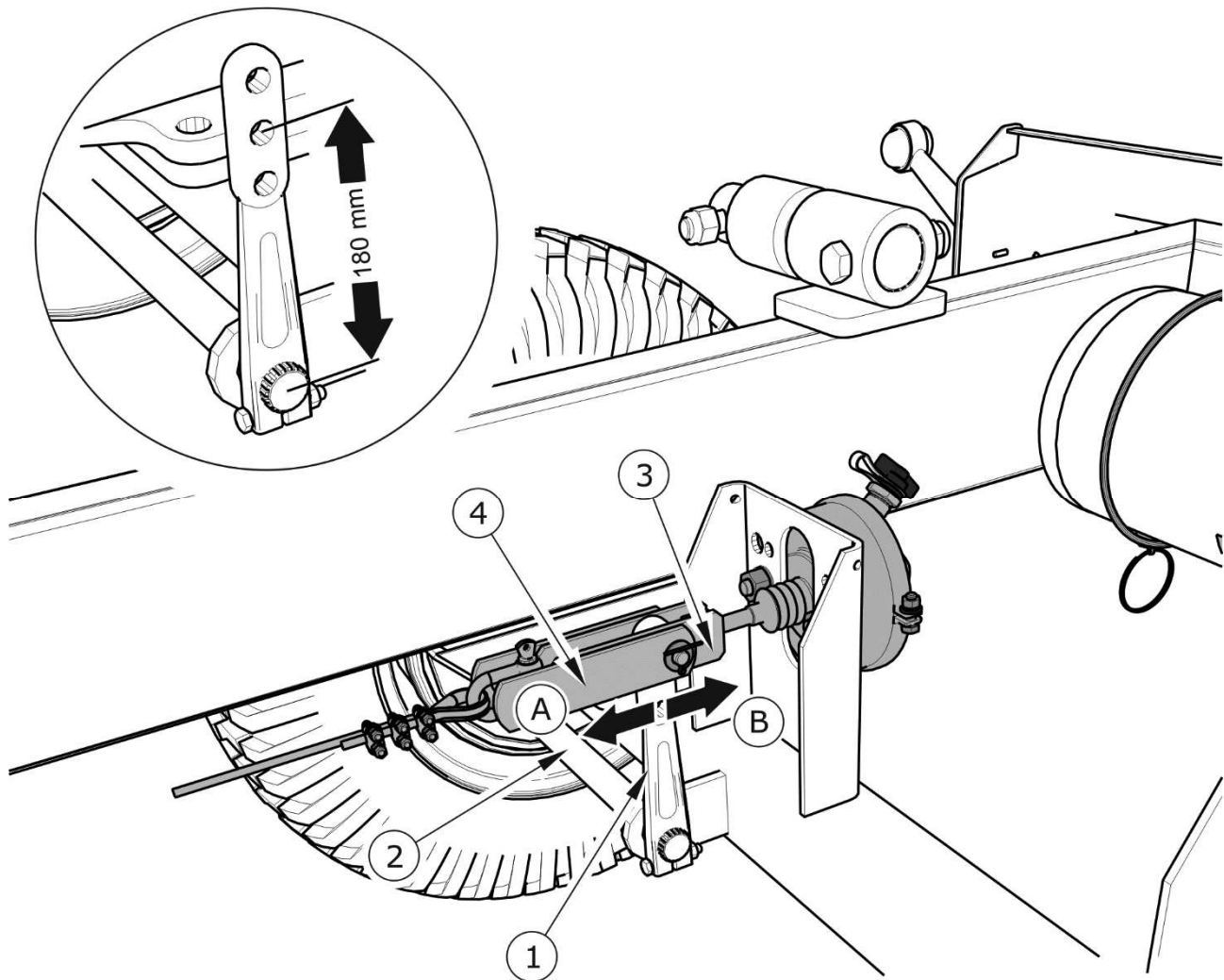

**FIGURE 5.4** Adjustment of axle mechanical brakes

(1) expander arm, (2) expander shaft, (3) cylinder fork, (4) handbrake release

Adjustment should be conducted separately for each wheel. Expander arm (1) should be moved by one notch in chosen direction. If the extent of cylinder action is still incorrect, move the lever again. After proper brake adjustment, at full braking, the expander arms should create the angle of  $90^{\circ}$  with the cylinder piston, and the stroke should amount to approximately half the length of the total stroke of the piston. After brake release, the expander arms may not be supported on any structural elements, because too little withdrawal of a piston ram may cause abrasion of brake shoes in drum and result in overheating the mixer feeder's brakes. Expander arms must be positioned in parallel with regard to each other at full braking. If this is not so, adjust the position of the lever, which has the longer stroke.



Remember or mark the original position of the pin in the expander arms. The mounting position is selected by the Manufacturer and may not be changed.

**TABLE 5.2** Position of the pin fixing the cylinder fork in the expander arm

TYPE OF BRAKE SYSTEM	PIN POSITION [mm]
Single conduit pneumatic system	180
Double conduit pneumatic system	180
Hydraulic brake system	180

### 5.2.8 REPLACEMENT OF PARKING BRAKE CABLE AND ADJUSTMENT OF CABLE TENSION.

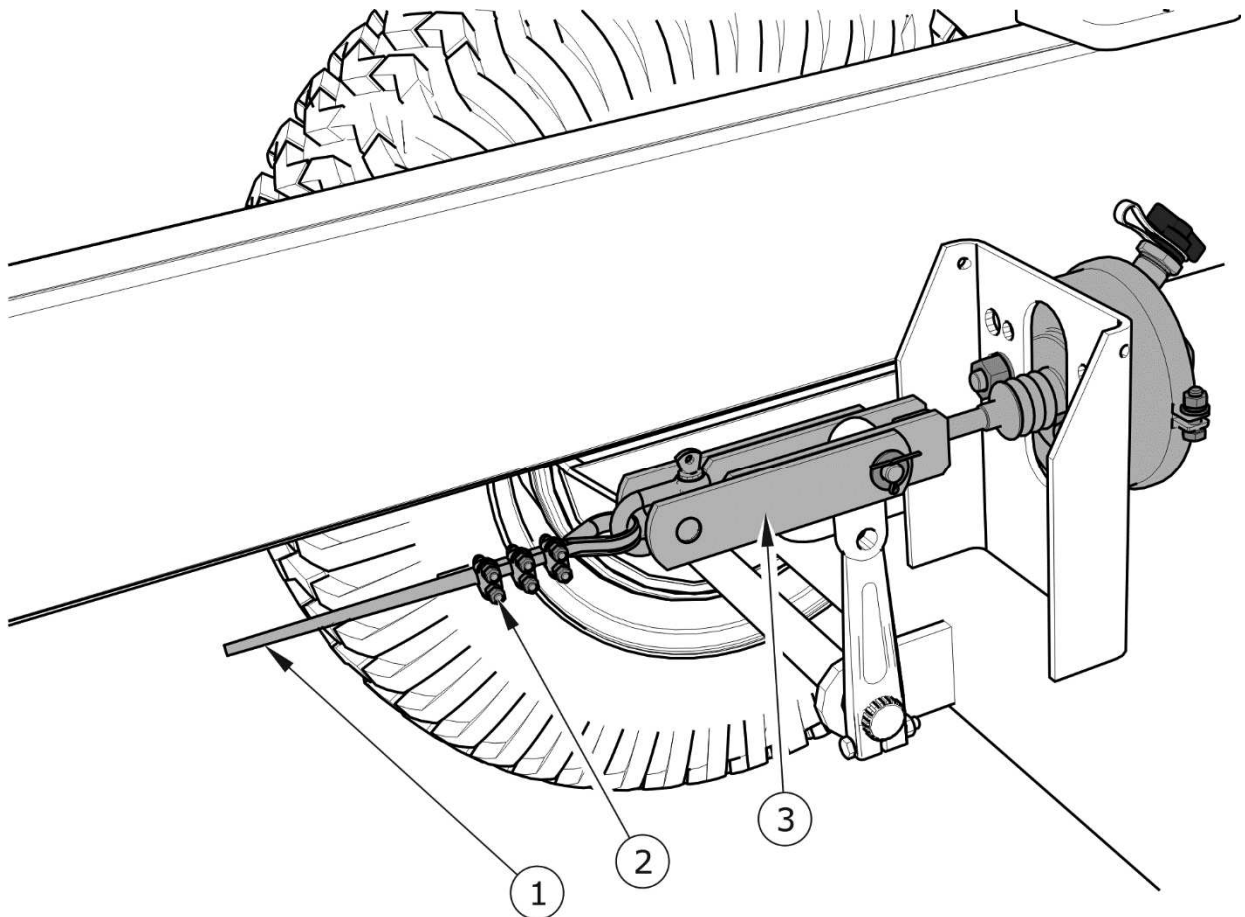

**FIGURE 5.5** Adjustment of parking brake cable tension

(1) parking brake cable, (2) nuts with clamps, (3) handbrake release

Proper operation of the parking brake is dependent on the effectiveness of the axle brake and the correct brake cable tension.

**Adjustment of parking brake cable tension**

- ➔ Hitch the mixer feeder to tractor. Park the mixer feeder and tractor on level surface.
- ➔ Place securing chocks under the mixer feeder wheel.
- ➔ Unscrew maximally the brake mechanism bolt (anticlockwise).
- ➔ Loosen nuts of handbrake cable clamps (2).
- ➔ Tighten cable and tighten clamps.
  - ⇒ Length of parking brake cable should be so selected that at total release of working and parking brake the cable would be loose and hanging by 1 - 2 cm.

Adjustment of parking brake cable tension should be conducted in the event of:

- stretching of cable,
- loosening of parking brake cable clamps
- after adjustment of axle brakes,
- after repairs of axle brake system,
- after repairs of parking brake system.

Before the adjustment, make certain that the axle brake is correctly adjusted and is functioning properly.

**Replacing the parking brake cable**

- ➔ Hitch the mixer feeder to tractor. Park the mixer feeder and tractor on level surface.
- ➔ Place wheel chocks under the machine wheel.
- ➔ Fully unscrew the bolt of the handbrake mechanism.
- ➔ Loosen nuts (3) of cable clamps (5) – figure (5.6).
- ➔ Dismantle cable (1).
- ➔ Lubricate parking brake mechanism and pins of cable guide rollers.
- ➔ Install new cable, adjust cable tension.

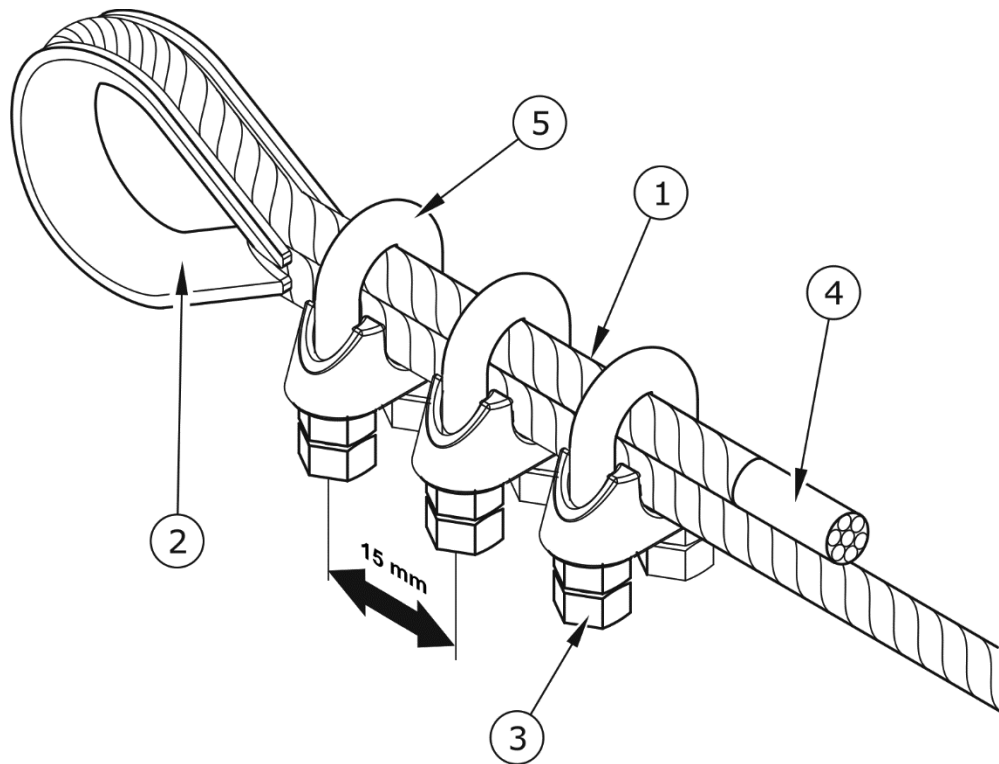

**FIGURE 5.6 Replacing the parking brake cable**

(1) brake cable, (2) thimble, (3) nut, (4) heat shrink tubing, (5) clamp

#### Replacing the parking brake cable

Parking brake cable must be fitted carefully. Protect the free end of the cable against damage using a heat shrink tubing or a band. Mount 3 clamps on each cable end as shown in figure (5.6), i.e. the nuts must be placed on the opposite side of the free cable end. Mount one clamp directly next to the thimble. Then, arrange the clamps in such a manner as to ensure that the distance between them exceeds 15 mm.



#### Checking and/or adjustment of parking brake:

- every 12 months,
- if needed.

## 5.3 PNEUMATIC SYSTEM MAINTENANCE

### 5.3.1 PRELIMINARY INFORMATION

Work connected with repair, replacement or regeneration of system components (brake cylinders, conduits, control valve, braking force regulator, etc.) should be entrusted to specialist establishments, having the appropriate technology and qualifications for this type of work.

The duties of the operator connected with the pneumatic system maintenance include:

- checking tightness and visual inspection of the system,
- cleaning the air filter (filters),
- draining water from air tank,
- cleaning drain valve,
- cleaning and maintaining pneumatic conduit connections,



### **DANGER**

Do NOT use the mixer feeder when brake system is unreliable.

### 5.3.2 CHECKING AIR TIGHTNESS AND VISUAL INSPECTION OF PNEUMATIC SYSTEM

#### Checking air tightness of pneumatic system

- ➔ Hitch the mixer feeder to tractor.
- ➔ Immobilise tractor and mixer feeder with parking brake. Additionally, place securing chocks under the mixer feeder wheel.
- ➔ Start the tractor in order to supplement air in the mixer feeder's brake system tank.
  - ⇒ In single conduit systems air pressure should amount to approx. 5.8 bar.

- ⇒ In double conduit systems air pressure should amount to approx. 8 bar.
- ➔ Turn off tractor engine.
- ➔ Check system components by releasing brake pedal in tractor.
  - ⇒ Pay particular attention to conduit connections and brake cylinders.
- ➔ Repeat the system check with depressed tractor brake pedal.
  - ⇒ The help of a second person is required.

In the event of the appearance of leaks, compressed air will escape at the places of damage, with a characteristic hiss. Lack of system tightness may be detected by covering checked elements with washing fluid or other foaming preparations, which will not react aggressively with the system components. It is recommended to use preparations commercially available designed to facilitate detecting air leaks. Damaged components should be replaced or repaired. If leaks appear at connections then tighten the connections. If air continues to escape, replace connection components or seals with new ones.



#### Check system tightness

- after travelling the first 1,000 km,
- each time after making repairs or changing system components,
- annually.

#### Visual inspection of the system

During tightness inspection attention should additionally be given to technical condition and degree of cleanness of the system components. Contact of pneumatic conduit seals etc. with oil, grease, petrol etc. may cause damage and accelerate the ageing process. Bent, permanently deformed, cut or worn conduits should be replaced.



#### Visual inspection of the system

- Conduct inspection of system at the same time as when checking tightness.

**ATTENTION**

Repair, exchange or regeneration of pneumatic system components may only be performed in a specialised workshop.

**5.3.3 CLEANING THE AIR FILTERS**

Depending on the mixer feeder working conditions, but not less than once in three months, take out and clean air filter elements, which are located in pneumatic system connection conduits. Filter elements are used many times and are not subject to change unless they are mechanically damaged.

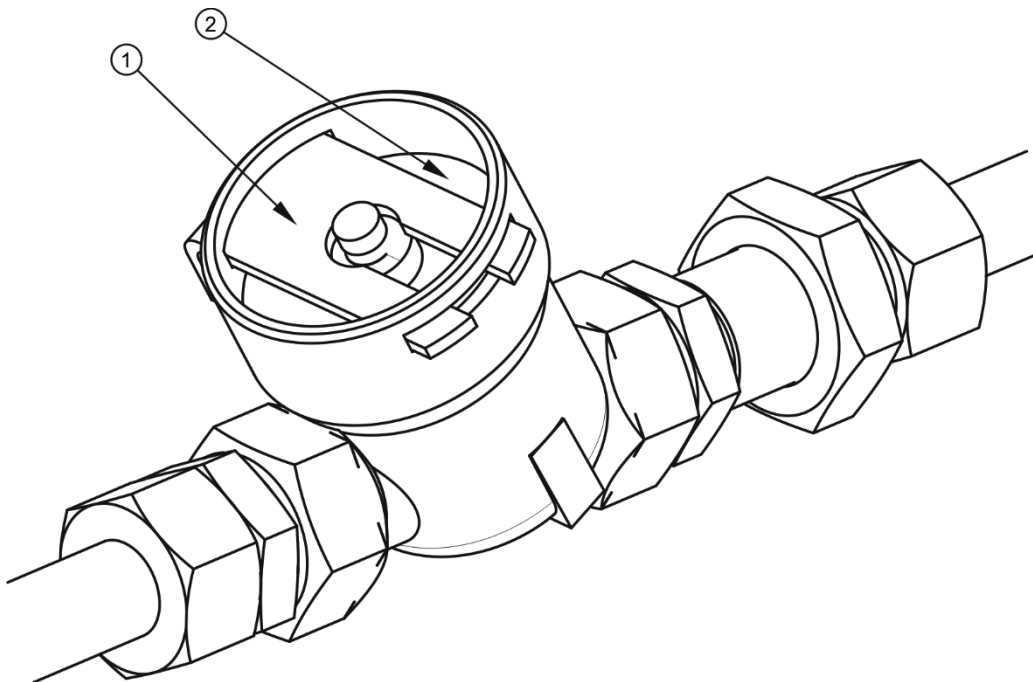

**FIGURE 5.7** Air filter

*(1) securing slide lock, (2) air filter cover*

**DANGER**

Before proceeding to dismantle filter, reduce pressure in supply conduit. While dismantling the slide lock, hold the cover with the other hand. Stand away from filter cover vertical direction.

**Required maintenance actions**

- ➔ Reduce pressure in supply conduit.
  - ⇒ Pressure in conduit can be reduced by pressing the head of the pneumatic connection until resistance is felt.
- ➔ Slide out securing slide lock (1) – figure (5.7).
  - ⇒ Hold the filter cover (2) with the other hand. After removing slide lock, the cover is pushed off by the spring located in the filter housing.
- ➔ The filter element and the filter body should be carefully cleaned and blown through with compressed air. Assembly should be done in reverse order.

**Cleaning the air filter (filters):**

- every 3 months of use,

**5.3.4 DRAINING WATER FROM AIR TANK****Required maintenance actions**

- ➔ Tilt drain valve stem (2) placed in the lower part of the tank (1) – the tank is placed on the brackets of the rear crossbar of the frame.
  - ⇒ The compressed air in the tank causes the removal of water to the exterior.
- ➔ Released valve stem should automatically close and stop flow of air from the tank.
  - ⇒ If the valve stem resists returning to its position, then the whole drain valve must be unscrewed and cleaned or replaced (if it is damaged) - see section 5.3.5.

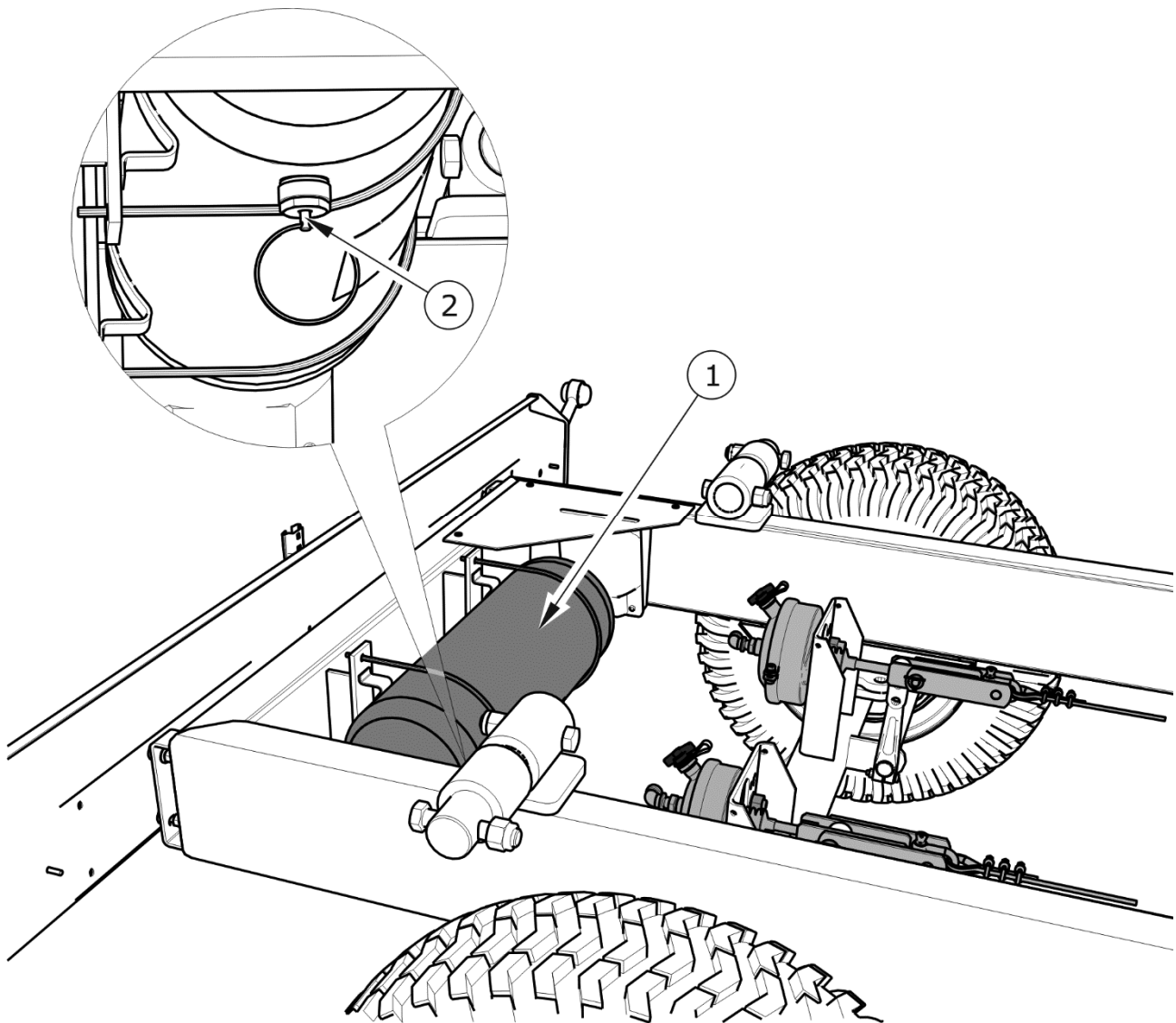

**FIGURE 5.8** Draining water from air tank

(1) air tank, (2) drain valve

	<p><b>Draining water from air tank:</b></p> <ul style="list-style-type: none"><li>• every seven days of use.</li></ul>
--	--



### 5.3.5 CLEANING THE DRAIN VALVE



#### **DANGER**

Release air from the air tank before dismantling drain valve.

#### **Required maintenance actions**

- ➔ Completely reduce pressure in air tank.
  - ⇒ Reduction of pressure in tank is achieved by tilting the drain valve stem.
- ➔ Unscrew valve.
- ➔ Clean the valve, blow it with compressed air.
- ➔ Change copper seal.
- ➔ Screw in valve, fill tank with air and check tank tightness.



#### **Cleaning valve:**

- every 12 months (before winter period).

### 5.3.6 CLEANING AND MAINTAINING PNEUMATIC CONDUIT CONNECTIONS



#### **DANGER**

Unreliable and contaminated mixer feeder connections may cause malfunctioning of the brake system.

Connection with damaged body should be replaced. In the event of damage to cover or seal, change these elements for new reliable elements. Contact of pneumatic connector seals with oils, grease, petrol etc. may cause damage and accelerate ageing process.

If the mixer feeder is unhitched from the tractor, connections should be protected by covers or placed in their designated sockets. Before the winter period it is recommended to preserve the seal with special preparations (e.g. silicon grease for rubber elements).

Each time before hitching the machine, inspect technical condition and cleanness of connectors and sockets in tractor. If necessary, clean or repair tractor sockets.

**Checking the mixer feeder's connections:**

- each time before hitching to tractor.

## 5.4 HYDRAULIC SYSTEM MAINTENANCE

### 5.4.1 PRELIMINARY INFORMATION

Work connected with the repair, replacement or regeneration of hydraulic system components should be entrusted to specialist establishments, having the appropriate technology and qualifications for this type of work.

**TIP**

Bleeding of the hydraulic system is not required during normal operation of the mixer feeder.

The duties of the operator connected with the hydraulic system maintenance include:

- checking tightness and visual inspection of the system,
- checking technical condition of hydraulic connections.

**DANGER**

Do NOT use the mixer feeder when the hydraulic brake system is unreliable.

### 5.4.2 CHECKING HYDRAULIC SYSTEM TIGHTNESS

#### Required maintenance actions

- ➔ Hitch the mixer feeder to tractor.
- ➔ Connect all hydraulic system conduits according to maintenance instructions.

- ➔ Clean connectors and hydraulic cylinders.
- ➔ Open and close the tank's slide gates several times.
- ➔ Press tractor brake pedal several times
  - ⇒ If the mixer feeder is equipped with hydraulic brake system.
- ➔ Check cylinders and hydraulic conduits for tightness.

If oil leak is detected on hydraulic cylinder body, ascertain origin of leak. Inspect seals when hydraulic cylinder is completely extended. Minimum leaks are permissible with symptoms of "sweating", however in the event of noticing leaks in the form of "droplets" stop using the mixer feeder until faults are remedied. If unreliability is evident in brake cylinders, do NOT use the mixer feeder with damaged system until faults are remedied. If leaks appear at connections then tighten the connections.

**Checking tightness:**

- after the first week of use,
- every 12 months of use.

### 5.4.3 CHECKING TECHNICAL CONDITION OF HYDRAULIC COUPLERS AND SOCKETS.

Hydraulic connections must be technically reliable and kept clean. Each time before connecting, check if socket in tractor are maintained in good working condition. Hydraulic systems of the tractor and mixer feeder are sensitive to the presence of permanent contamination, which may cause damage to precision system components.

**Inspection of hydraulic couplers and sockets:**

- each time before hitching the mixer feeder to tractor.

### 5.4.4 REPLACEMENT OF HYDRAULIC CONDUITS

Rubber hydraulic conduits must be replaced every 4 years regardless of their technical condition. This should be done in specialised workshops.

	<p><b>Replacement of hydraulic conduits:</b></p> <ul style="list-style-type: none"> <li>• every 4 years.</li> </ul>
---	---

## 5.5 LUBRICATION OF MIXER FEEDER

Lubrication of mixer feeder should be performed with the aid of a manually or foot operated grease gun, filled with recommended grease. Before commencing work insofar as is possible remove old grease and other contamination. Remove and wipe off excess oil or grease.

Parts to be lubricated with machine oil should be wiped with dry clean cloth and then a small quantity of oil should be applied to their surfaces (using oil can or brush). Wipe off excess oil.

Change of grease in hub bearings should be entrusted to specialised service points, equipped with the appropriate tools. According to the recommendations of the axle Manufacturer, dismantle the entire hub, remove the bearing and individual sealing rings. After careful washing and inspection, mount lubricated elements. If necessary, bearing and seals should be replaced with new parts. Lubrication of axle bearings shall be performed at least once in 2 years or every 50,000 km. In the event of intensive use, lubrication should be performed more frequently.

Empty grease or oil containers should be disposed of according to the recommendations of the lubricant Manufacturer.

**TABLE 5.3 Mixer feeder lubrication schedule**

ITEM	LUBRICATION POINT	NUMBER OF LUBRICATION POINTS	TYPE OF GREASE	FREQUENCY
1	Hub bearing	4	A	24M
2	Drawbar eye	1	B	14D

ITEM	LUBRICATION POINT	NUMBER OF LUBRICATION POINTS	TYPE OF GREASE	FREQUENCY
3	Parking brake mechanism	1	A	6M
4	Parking brake guide roller pins	1	A	6M
5	Multi-splined transmission shaft	1	B	30H
6	Multi-splined shaft of PTO connector	2	B	30H
7	Chute guides	4	C	3M
8	Eyes of slide gate opening hydraulic cylinders	4	A	1M
9	Rotating drawbar eye	1	B	1M
10	Support screw	1	A	12M

*lubrication periods – M month, D – days, H – hour*

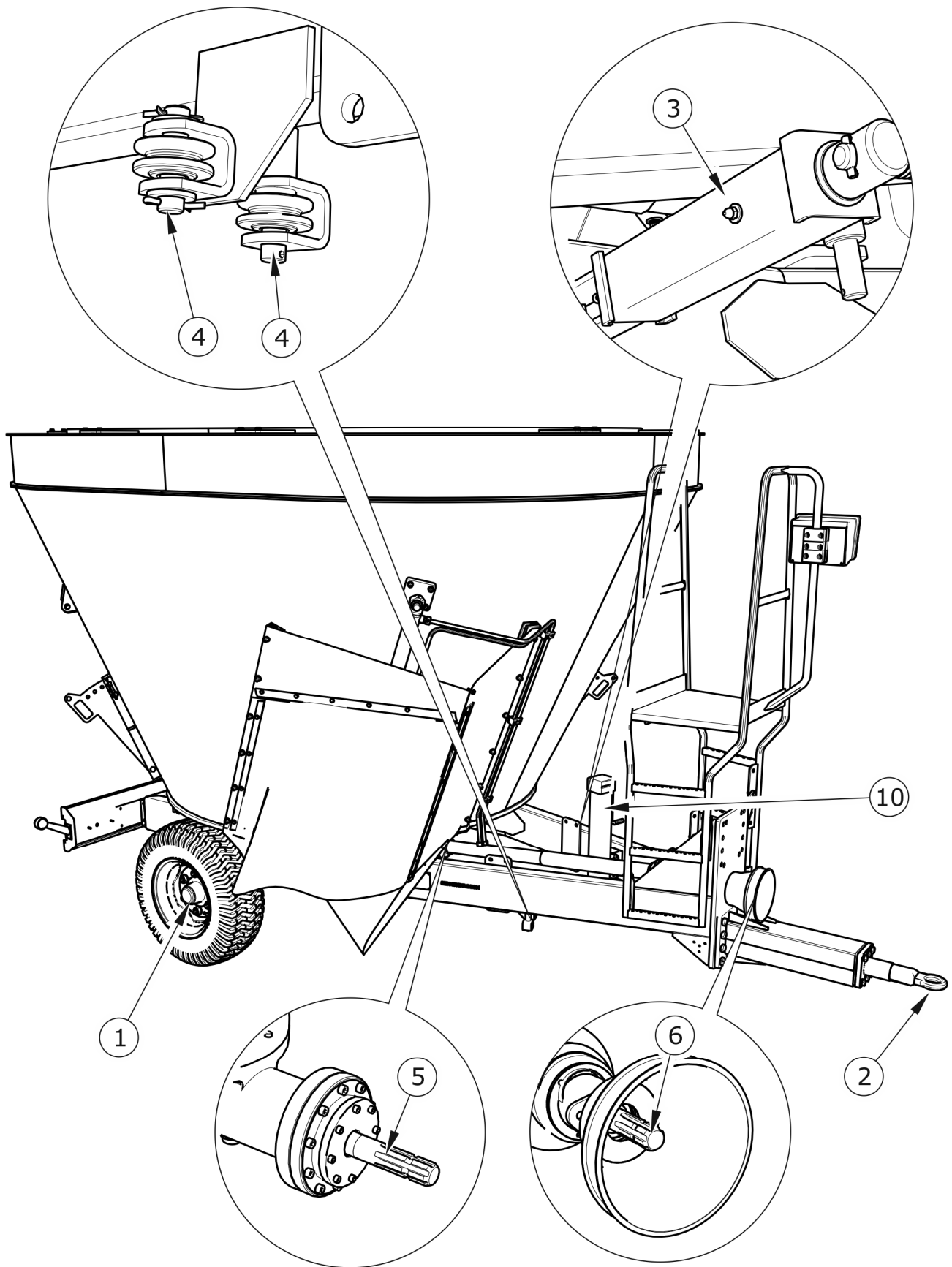

**FIGURE 5.9** Mixer feeder's lubrication points, part 1

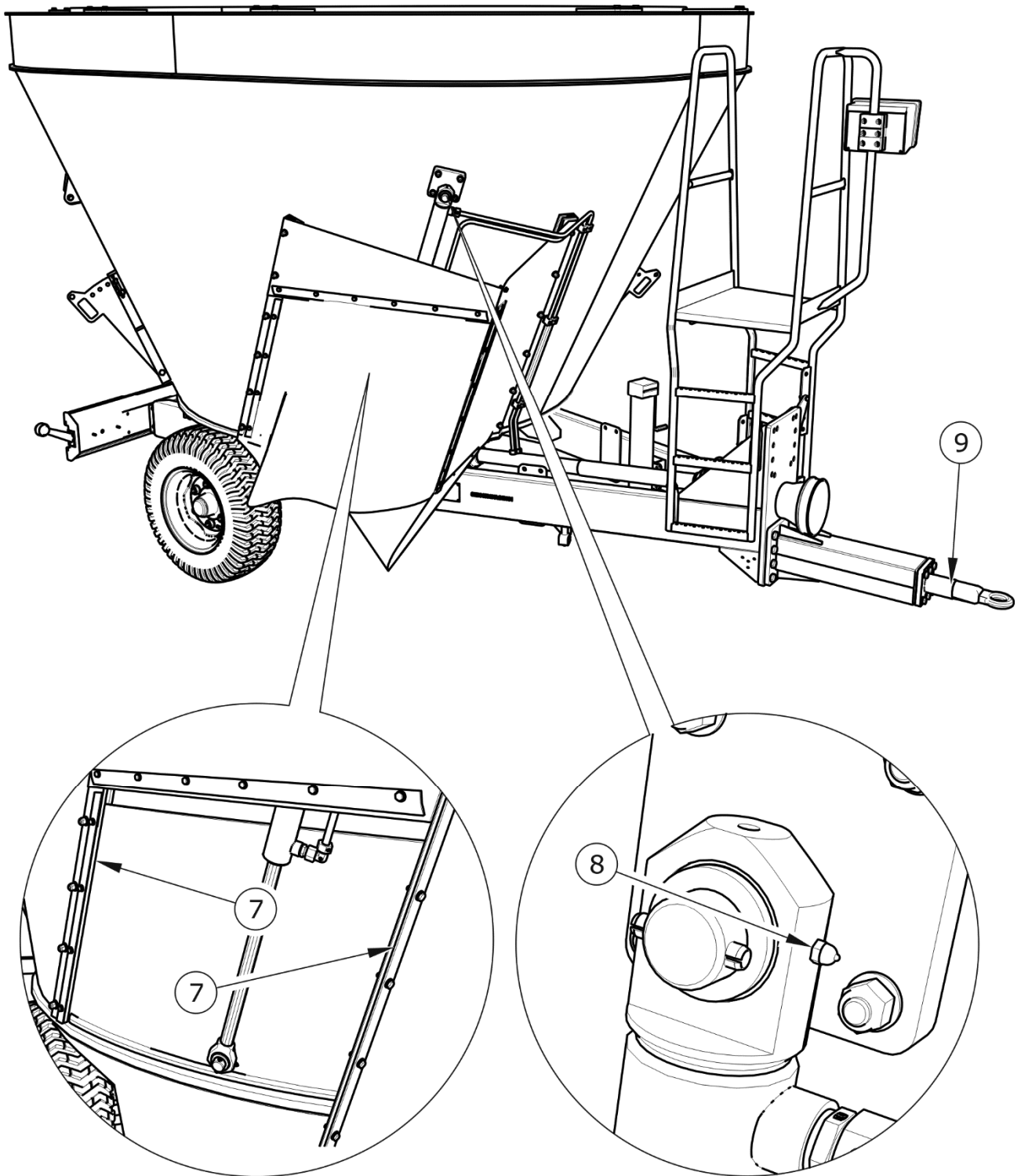



FIGURE 5.10 Mixer feeder's lubrication points, part 2

**TABLE 5.4 Recommended lubricants**

MARKING ACCORDING TO TAB. (5.3)	DESCRIPTION
A	machine general-purpose grease (lithium, calcium grease),
B	permanent grease for heavily loaded elements with addition of MOS <sub>2</sub> or graphite
C	biodegradable oil

When using the mixer feeder, lubricate also the PTO shafts according to the instructions of their manufacturers. For detailed information on PTO shaft maintenance, please refer to the user's manual of the shaft.



**When using the mixer feeder, the user is obliged to observe lubrication instructions according to lubrication schedule.**

## 5.6 CONSUMABLES

### 5.6.1 HYDRAULIC OIL

**TABLE 5.5 L-HL 32 Lotos hydraulic oil characteristics**

ITEM	NAME	UNIT	VALUE
1	ISO 3448VG viscosity classification	-	32
2	Kinematic viscosity at 40 <sup>0</sup> C	mm <sup>2</sup> /s	28.8 – 35.2
3	ISO 6743/99 quality classification	-	HL
4	DIN 51502 quality classification	-	HL
5	Flash-point	C	230

Always adhere to the principle that the oil in the mixer feeder hydraulic system and in the tractor hydraulic system are of the same type. In the event of application of different types of oil make certain that both hydraulic substances may be mixed together. Application of



different oil types may cause damage to mixer feeder or tractor. In a new machine, the hydraulic system is filled with L HL32 Lotos hydraulic oil.

If it is necessary to change hydraulic oil for another oil, check the recommendations of the oil Manufacturer very carefully. If it is recommended to flush the system with the appropriate preparation, then comply with these recommendations. Attention should be given, so that chemical substances used for this purpose do not damage the materials of the hydraulic system. During normal use of the mixer feeder, change of hydraulic oil is not necessary, but if required, this operation should be entrusted to a specialist service point.

Because of its composition, the oil is not classified as a dangerous substance, however long-term action on the skin or eyes may cause irritation. In the event of contact of oil with skin wash the place of contact with water and soap. Do NOT apply organic solvents (petrol, kerosene). Contaminated clothing should be changed to prevent access of oil to skin. In the event of contact of oil with eye, rinse with large quantity of water and in the event of the occurrence of irritation consult a doctor. Hydraulic oil in normal conditions is not harmful to the respiratory tract. A hazard only occurs when oil is strongly atomised (oil vapour), or in the case of fire during which toxic compounds may be released.



### **DANGER**

**Oil fires should be quenched with the use of carbon dioxide, foam or steam extinguishers. Do not use water to quench oil fires.**

## **5.6.2 LUBRICANTS**

For heavily loaded parts it is recommended to apply lithium greases with addition of molybdenum disulphide ( $\text{MOS}_2$ ) or graphite. In the case of less loaded sub-assemblies the application of general purpose machine greases is recommended, which contain anticorrosive additives and have significant resistance to being washed away by water. Aerosol preparations (silicon greases and anticorrosive-lubricating substances) should have similar characteristics.

Before starting to use greases acquaint oneself with the content of the information leaflet for the chosen product. Particularly relevant are safety rules and handling procedures for a given lubricant as well as waste disposal procedure (used containers, contaminated rags etc.). Information leaflet (material safety data sheet) should be kept together with grease.

## 5.7 REDUCTION GEAR MAINTENANCE

Maintenance of the reduction gear is conducted during general inspection, change or topping up gear oil. In the event of damage to the reducer, contact authorised service point in order perform repairs.

First oil change must be made after the first 100 hours worked. The next oil change should be made after 2,000 hours of the mixer feeder work or once a year.



### ATTENTION

If the amount of transmission oil added in order to reach the correct level (after 100 working hours) is greater than 1.5 litres, it is an indication of transmission oil leakage. Please contact the service centre for repair.

### Oil change

- ➔ Unscrew the bleed conduit plug (1) – figure (5.11) and expansion tank plug (2).
- ➔ Unscrew drain plug (3).
- ➔ Drain oil into an oil-resistant tight container, the container capacity should be about 20 litres.
- ➔ Clean the drain plug, replace the seal.
  - ⇒ The drain plug contains a magnetic filter.
- ➔ If the oil manufacturer recommends flushing transmission with washing detergent, that operation should be performed according to the guidelines of the oil manufacturer.
- ➔ Tighten drain plug (3).
- ➔ Unscrew the plug (4).
- ➔ Remove the bleed conduit (5) and place it below the tank bottom in such a manner as to ensure that all oil can freely flow out of the conduit.
- ➔ Pour oil into the oil tank (6) until oil starts flowing out through the plug opening (4).

➔ Tighten plug (4).

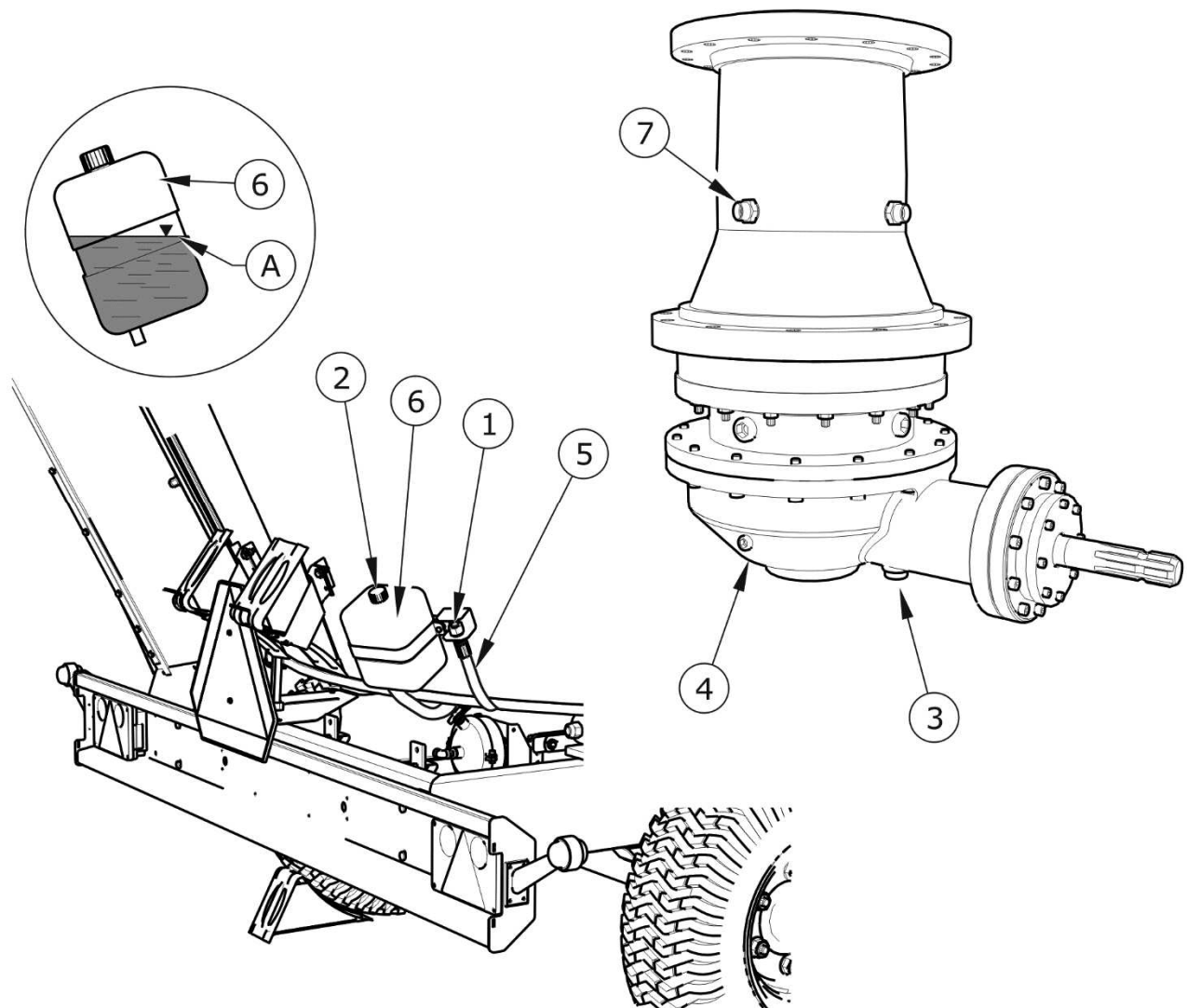

**FIGURE 5.11 Oil change**

(1) bleed plug, (2) expansion tank nut, (3) transmission drain plug, (4) plug, (5) bleed conduit, (6) expansion tank, (7) bleed conduit connector, (A) oil level in expansion tank

- ➔ Add oil to the transmission to the level of overflow connector (7).
  - ⇒ If oil appears in the bleed conduit, mount the conduit in the holder.
- ➔ Add oil to level (A) in the expansion tank.
- ➔ Tighten the oil expansion tank plug (2) and bleed plug (1).

When changing the oil, also change the washers under the plugs.



**TIP**

The transmission holds 16 litres of oil.

**TABLE 5.6 Requirements for transmission lube oil**

VISCOSITY CLASSES ACC. TO AGMA		KINEMATIC VISCOSITY AT 40 <sup>0</sup> C, [mm <sup>2</sup> /s]	VISCOSITY CLASSES ISO 3448
R&O	EP		
5	5 EP	198 – 242	VG 220



Check the oil level in the system each time before starting the machine. If oil level is insufficient, add oil. Check that the bleed opening in the oil tank plug is not blocked (1).



**ATTENTION**

The transmission housing temperature must not exceed 80<sup>0</sup> C. If the transmission housing overheats, contact the service centre.

## 5.8 ADJUSTING DRAWBAR TO TRACTOR HITCH

Before hitching the mixer feeder to tractor, it is important to adjust the drawbar in such a manner as to level the machine. Figure (5.12) shows two available drawbar settings. Changing the drawbar position should be performed by two persons.

## Changing the drawbar position

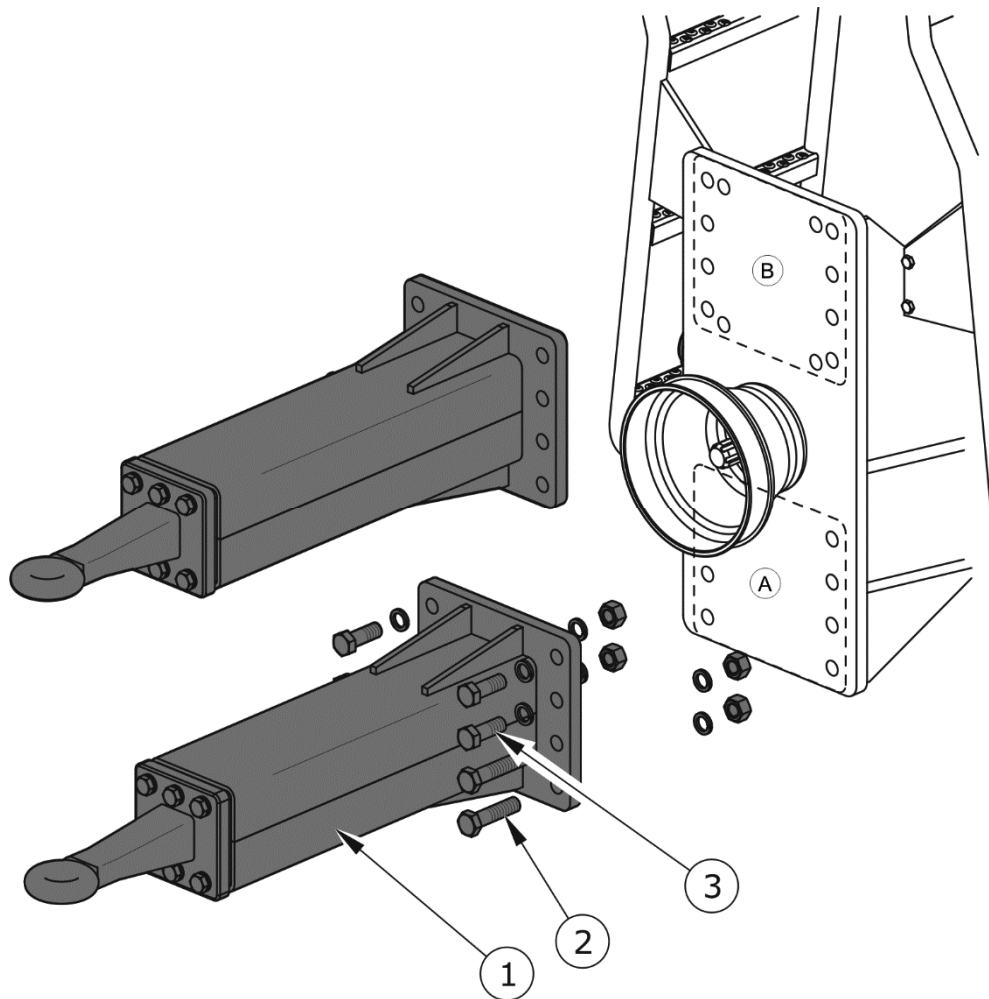

**FIGURE 5.12 Adjustment of drawbar position**

(1) drawbar, (2) - (3) bolt and nut connection of the drawbar and the frame front plate

- ➔ Position the mixer feeder on a flat surface, place chocks under its wheel.
- ➔ Immobilise the mixer feeder with parking brake.
- ➔ Undo nuts of drawbar fixing bolts (2) and remove bolts,
- ➔ Unscrew bolts (3) from threaded plate,
- ➔ Set the drawbar to a new position.
- ➔ Tighten the elements using proper tightening torque.

To change the drawbar position from the lower position (A) to the upper position (B), replace the bolt and nut connection (3) with the elements specified in table (5.7)

**TABLE 5.7 Drawbar bolt and nut connection**

<b>DRAWBAR POSITION</b>	<b>SPECIFICATION ACC. TO FIGURE 5.12</b>	<b>CONNECTION TYPE</b>	<b>PCS</b>
<b>UPPER (B)</b>	Bolt and nut connections (2) and (3)	Bolt M20x80-10.9-B-Fe/Zn5 PN-85/M-82101	8
		Nut M20-10-B Fe/Zn5 PN-86/M-82144	8
		Spring washer Z20.5 PN - 77/M-82008	8
<b>LOWER (A)</b>	Bolt and nut connection (2)	Bolt M20x80-10.9-B-Fe/Zn5 PN-85/M-82101	4
		Nut M20-10-B Fe/Zn5 PN-86/M-82144	4
		Spring washer Z20.5 PN - 77/M-82008	4
	Bolt and nut connection (3)	Bolt M20x55-10.9-B-Fe/Zn5 PN-85/M-82101	4
		Nut M20-10-B Fe/Zn5 PN-86/M-82144	4
		Spring washer Z20.5 PN - 77/M-82008	4

**ATTENTION**



The mixer feeder's drawbar must be bolted with 8 bolts.

After changing the position of the drawbar check the tightening torques of bolt connections after a day's work.

The drawbar position change should be performed by two persons.

## 5.9 DISASSEMBLY AND INSTALLATION OF CUTTING BLADES

Depending on the mixer feeder operation mode, the cutting blades should be sharpened, adjusted or replaced after some time. The life of the cutting blades is considerably shortened in the following cases:

- using high auger rotation speeds,
- presence of foreign bodies in the feed (sand, stones, etc.)

Stones entering the tank may damage the cutting blades to such a degree that it will be necessary to change the blades (bending, cracks, fractures). Presence of sand in the feed mixture causes several times faster blade wear. The worn blades may be reused provided that they are properly regenerated. If the auger works in nominal working conditions and there are no foreign bodies in the feed, the life of the blades is approximately 500 hours.

The person disassembling or installing the cutting blades must enter the mixer feeder tank.

### Disassembly of blades

- ➔ Prepare the mixer feeder before entering the tank.
  - ⇒ Read the section (5.12).
- ➔ Undo 3 nuts (5), remove washers (6) and take out screws (4) – figure (5.13),
- ➔ Unscrew bolt and nut connection of blade I (1) and dismount blade I.
- ➔ Unscrew bolt and nut connection of blade II (2) and dismount blade II.

Installation should be done in reverse order using new nuts. Bolt and nut connection should be tightened using proper tightening torque.

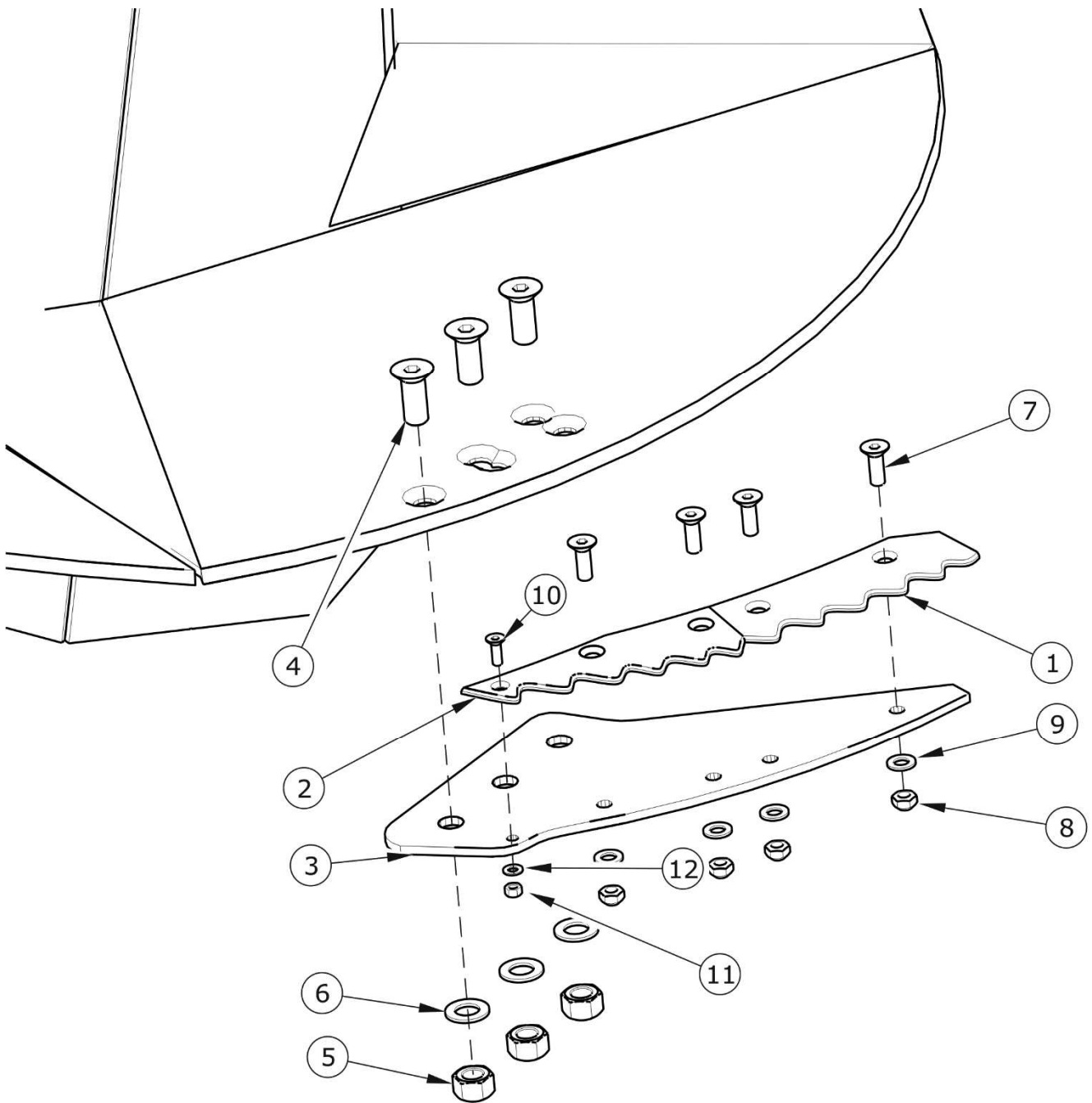

**FIGURE 5.13** Disassembling the cutting blades

(1) cutting blade I, (2) cutting blade II, (3) blade base, (4), (7), (10) cone headed screw, (5), (8), (11) self locking nut, (6), (9), (12) flat washer



**DANGER**

Since the cutting blades are very sharp, exercise due caution when mounting and dismounting them.

Do NOT disassemble the blades through the open feed dispensing window – danger of crushing the whole body.

**TIP**

The blades can be disassembled without unscrewing the blade base (3) – figure (5.13). The complete disassembly should be performed only in order to maintain the whole element or make a repair.

## 5.10 ADJUSTING THE POSITION OF CUTTING BLADES

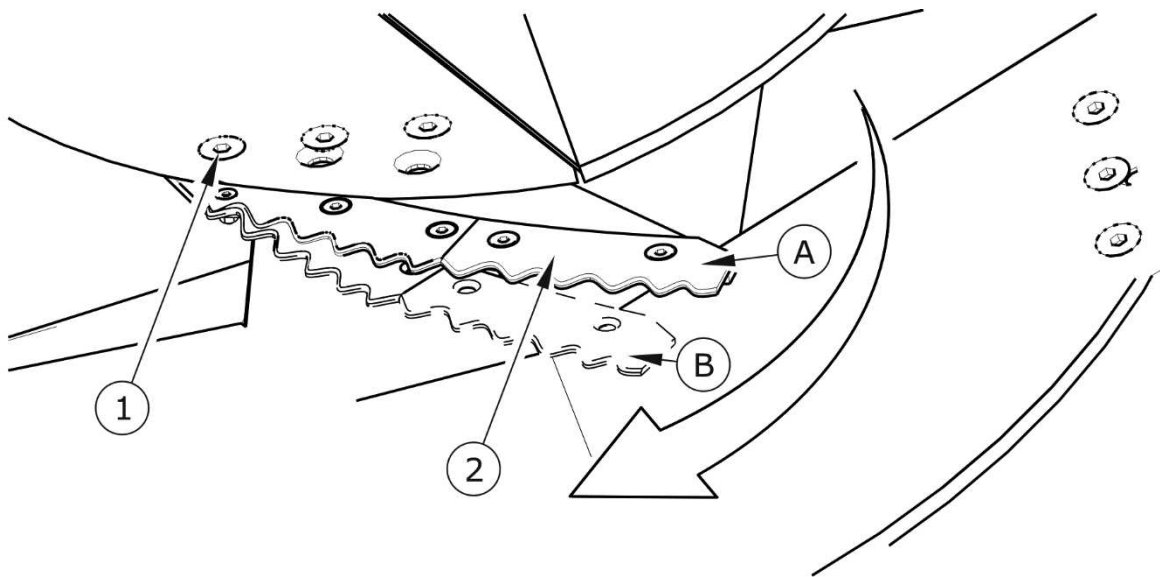

**FIGURE 5.14** Adjusting the position of cutting blades

(1) bolt and nut connection, (2) blade, (A), (B) – available cutting blade positions

The degree of feed disintegration depends not only on the auger rotation speed but also on the proper position of cutting blades. Figure (5.14) shows 2 available blade working positions. Position (A) is the standard position. In position (A), the disintegration degree is the smallest.

In position (B), the disintegration degree is the largest. The degree of the blade wear is also the largest in position (B).

### Adjustment

- ➔ Prepare the mixer feeder for entering the tank.
- ➔ Loosen the nuts of the bolt and nut connection (1), remove the screws.
- ➔ Set the blade in a selected working position.
- ➔ Install screws and tighten the bolt and nut connection using proper tightening torque.



### **DANGER**

Since the cutting blades are very sharp, exercise due caution when adjusting them.

## 5.11 SHARPENING THE CUTTING BLADES

The knives should be sharpened in grinding workshops which have proper tools for this type of work. Sharpening consists in grinding the factory-machined surface using a grindstone in such a manner as to achieve the angle of 22-23<sup>0</sup>. During sharpening, the blade must be very intensively cooled. Overheated knife must not be further used because the cutting edge hardness is reduced.

Sharpening the knives with an angle grinder is permissible. Take breaks when sharpening the knives with an angle grinder in order to cool down the knives. When sharpening the knives, pay attention to the colour of the knife edge so as not to overlook the tempering process.

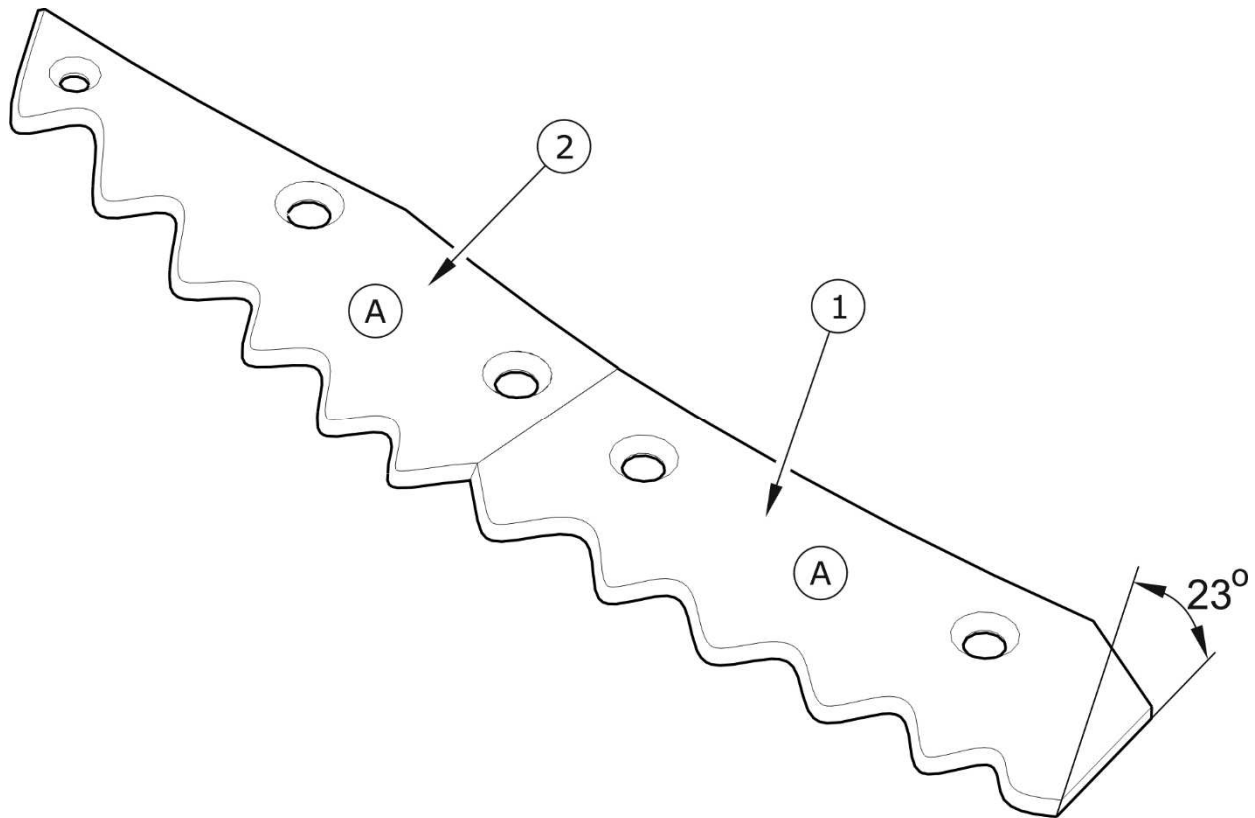

**FIGURE 5.15**      **Blade sharpening principle**

*(1) cutting blade I, (2) cutting blade II, (A) upper blade surface*



The blade cutting edge should be checked at least every two weeks of the mixer feeder use.

When sharpening the knives, pay special attention to the sharp edge of the cutting element. During this activity, use sufficiently thick gloves and safety goggles.



**TIP**

Properly sharpened blades shorten the feed preparation time and reduce fuel consumption.

## 5.12 ENTERING THE TANK

During the mixer feeder operation there is often a need to enter the tank in order to adjust or clean the tank and the auger mixer. This must be done with extreme caution because of the high risk of accident. In order to do this:

- ➔ immobilise tractor and mixer feeder with parking brake.
- ➔ dismantle PTO shaft
- ➔ place securing chocks under the mixer feeder wheel,
- ➔ open the slide gates on both sides of the mixer feeder,
- ➔ turn off the tractor engine and remove the key from the ignition,
- ➔ secure tractor against unauthorised access,
- ➔ disconnect the slide gate hydraulic system conduits, disconnect PTO shaft connecting tractor and mixer feeder,
- ➔ prepare 2 sufficiently high ladders,
- ➔ lean one ladder against the wall extension edge and put the other ladder into the tank; make certain that the ladders are standing firmly and will not move when climbing them up/down,
- ➔ enter the tank while exercising due caution and paying attention to protruding and sharp objects (cutting blades).



### **DANGER**

**Before entering the tank, make sure unauthorised persons do not have access to the tractor, disconnect PTO shaft, open the slide gates and disconnect hydraulic system conduits from the tractor.**

When entering the tank, do not use the mixer feeder's platform and the chute openings because they are not designed for this purpose. When entering the tank, be careful not to stand on the blades. Several cutting blades installed in the lower part of the auger mixer can be also accessed through the chute opening on the left side or the right side of the mixer feeder.

**DANGER**

Exercise particular caution when entering the tank.

Entering the tank is possible only with the use of 2 ladders. Do NOT use the platform or chute opening for this purpose.

While entering the tank, the mixer feeder must be absolutely motionless.

## 5.13 CLEANING THE MIXER FEEDER

The mixer feeder tank together with the auger mixer and chute shields must be cleaned after each use and longer (several days) standstill of the mixer feeder. Other components should be cleaned as needed. Before using pressure washer the user is obliged to acquaint himself with the operating principles and recommendations concerning safe use of this equipment.

### The mixer feeder cleaning guidelines

- Before cleaning the mixer feeder, open the tank slide gates. Carefully remove the remains of feed from the auger mixer (for example, blow out with compressed air).
- To wash the tank interior, the auger mixer and the chute shields, use clean running water only; in other cases you may use water with a cleaning detergent with neutral pH.
- Using pressure washer increases washing effectiveness, but particular care must be taken during work. During washing, washer nozzle may not be closer than 50 cm from the surface being cleaned.
- Water temperature should not exceed 55 °C.
- Do not direct a water jet directly at system elements and equipment of the mixer feeder i.e. control valve, braking force regulator, brake cylinders, pneumatic, electric and hydraulic plugs, lights, electrical connections, information and warning decals, identification plate, conduit connections and lubrication points etc. Great water jet pressure may damage these elements.
- For cleaning and maintenance of plastic coated surfaces it is recommended to use clean water or special preparations designed for this purpose.

- Do not apply organic solvents, preparations of unknown origin or other substances, which may cause damage to lacquered, rubber or plastic surfaces. In the event of doubt it is recommended to make a test on an unseen surface area.
- Surfaces smeared with oil or grease should be cleaned by application of benzene or other degreasing agents and then washed with clean water with added detergent. Comply with recommendations of the Manufacturer of cleaning agents.
- Detergents should be kept in original containers, optionally in replacement containers, but very clearly marked. Preparations may not be stored in food and drink containers.

## **DANGER**



**Carefully read the instructions for application of detergents and maintenance preparations.**

**While washing with detergents wear appropriate protective clothing and goggles protecting against splashing.**

- Ensure cleanliness of elastic conduits and seals. The plastic from which these elements are made may be susceptible to organic substances and some detergents. As a result of long-term reaction of some substances, the ageing process may be accelerated and risk of damage increased. Rubber elements should be maintained with the aid of special preparations after previous thorough washing.
- Observe environmental protection principles and wash the mixer feeder in a place designed for this purpose.
- Cleaning and drying of the mixer feeder must take place at temperatures above 0 °C.

## **5.14 STORAGE**

- Mixer feeder should be stored in a closed or roofed building.
- If the machine will not be used for a long time, it is essential to protect it from adverse weather, especially rust and accelerated tyre deterioration. During this

time the machine must be unloaded. Mixer feeder should be very carefully washed and dried.

- Corroded places should be cleaned of rust, degreased and protected using undercoat paint and then painted with surface paint according to colour scheme.
- In the event of a prolonged work stoppage, it is essential to lubricate all components regardless of the date of the last lubrication.
- Wheel rims and tyres should be carefully washed and dried. During a longer storage of unused mixer feeder, it is recommended that every 2 to 3 weeks the machine should be moved a bit so that the place of contact of tyres with ground is changed. The tyres will not be deformed and maintain proper geometry. Also, air pressure in tyres should be inspected from time to time and, if necessary, pressure should be increased to appropriate value.
- PTO shafts should be stored in horizontal position.

## 5.15 TIGHTENING TORQUE FOR NUT AND BOLT CONNECTIONS

Unless other tightening parameters are given, during maintenance repair work apply appropriate torque to tighten nut and bolt connections. Recommended tightening torque for the most frequently used nut and bolt connections are given in table below. Given values apply to non-lubricated steel bolts.

**TABLE 5.8 Tightening torque for nut and bolt connections**

METRIC THREAD	5.8 <sup>(1)</sup>	8.8 <sup>(1)</sup>	10.9 <sup>(1)</sup>
	Md [Nm]		
M10	37	49	72
M12	64	85	125
M14	100	135	200
M16	160	210	310
M20	300	425	610

METRIC THREAD	5.8 <sup>(1)</sup>	8.8 <sup>(1)</sup>	10.9 <sup>(1)</sup>
	Md [Nm]		
M24	530	730	1 050
M27	820	1 150	1 650
M30	1 050	1 450	2 100

<sup>(1)</sup> – strength class according to DIN ISO 898 standard

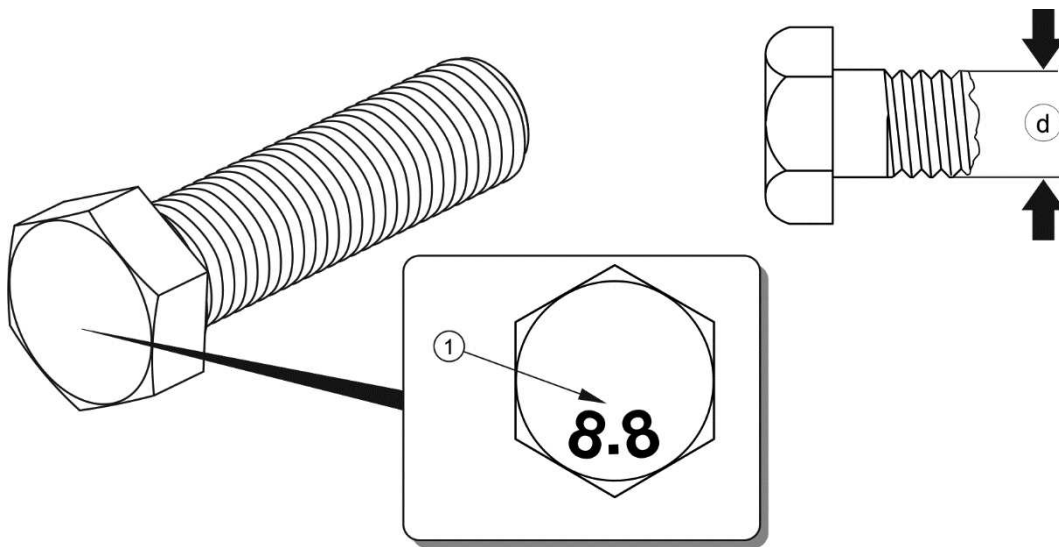

**FIGURE 5.16 Bolt with metric thread**

*(1) strength class, (d) thread diameter*



**TIP**

Hydraulic conduits should be tightened using torque of 50 – 70 Nm.



## 5.16 MAINTENANCE OF ELECTRICAL SYSTEM AND WARNING ELEMENTS

### 5.16.1 PRELIMINARY INFORMATION

Work connected with the repair, change or regeneration of electrical system components should be entrusted to specialist establishments, having the appropriate technology and qualifications for this type of work.

The responsibilities of the user are limited to:

- technical inspection of electrical system and reflectors,
- changing bulbs



#### ATTENTION

Do NOT travel with out of order lighting system. Damaged lamp lenses, and burned-out bulbs must be replaced immediately before travelling. Lost or damaged reflective lights must be replaced.

#### Required maintenance actions

- ➔ Connect the mixer feeder to tractor with appropriate connection lead.
  - ⇒ Check if the connection lead is reliable. Check connection sockets in tractor and mixer feeder.
- ➔ Check completeness and technical condition of the mixer feeder's lights.
- ➔ Check completeness of all reflectors.
- ➔ Check correct mounting of the slow-moving vehicle warning sign holder.
- ➔ Before driving on to public road, check that the tractor is equipped with a warning reflective triangle.



#### Checking technical condition of electrical system:

- each time when hitching the mixer feeder.



**TIP**

Before driving off, make certain that all lamps and reflective lights are clean.

### 5.16.2 REPLACEMENT OF BULBS

Compatible bulbs are shown in table (5.9). All light lenses are secured by screws and it is not necessary to dismantle whole lamp or the mixer feeder's subassemblies.

**TABLE 5.9 List of bulbs**

LAMP	LAMP TYPE	BULB / QUANTITY IN 1 LAMP	NUMBER OF LAMPS
Rear left lamp assembly	W21L	R10W – 1 unit P21W – 3 units	1
Rear right lamp assembly	W21P	R10W – 1 unit P21W – 3 units	1
Left clearance lamp	127,022 00 00	R5W – 1 unit	1
Right clearance lamp	127,023 00 00	R5W – 1 unit	1

## 5.17 TROUBLESHOOTING

**TABLE 5.10 Troubleshooting**

FAULT	CAUSE	REMEDY
Problem with moving off	Brake system conduits not connected	Connect brake conduits (applies to pneumatic systems)
	Applied parking brake	Release parking brake.
	Damaged pneumatic system connection conduits	Replace.
	Leaking connections	Tighten, replace washers or seal sets, replace conduits.
	Control valve or braking	Check valve, repair or replace.

FAULT	CAUSE	REMEDY
	force regulator damaged	
Noise in axle hubs	Excessive bearing slackness	Check slackness and adjust if needed
	Damaged bearings	Replace bearings
	Damaged hub parts	Replace
Poor reliability of braking system Excessive heating of axle hubs	Insufficient pressure in the system	<p>Check pressure on tractor pressure gauge, wait till compressor fills tank to required pressure.</p> <p>Damaged air compressor in tractor Repair or replace.</p> <p>Damaged brake valve in tractor. Repair or replace.</p> <p>Leaking system conduits or connections. Check system for tightness.</p>
	Incorrect main or parking brake adjustment	Regulate positions of expander arms
	The high degree of brake linings wear	Change brake shoes
Incorrect hydraulic system operation	Improper hydraulic oil viscosity	Check oil quality, make sure that the oil in both machines is of the same type. If necessary change oil in tractor or in the mixer feeder
	Insufficient tractor hydraulic pump output, damaged tractor hydraulic pump.	Check tractor hydraulic pump.
	Damaged or contaminated cylinder	Check cylinder piston rod (bending, corrosion), check cylinder for tightness (cylinder piston rod seal), if necessary, repair or replace the cylinder.
	Excessive cylinder loading	Check and reduce cylinder load, if necessary

FAULT	CAUSE	REMEDY
	Damaged hydraulic conduits	Check and make certain that hydraulic conduits are tight, not fractured and properly tightened. If necessary, replace or tighten.
Reduction gear heats up	Insufficient amount of oil in the gear	Check oil level in the expansion tank and in the gear. Add oil to the required level.
	Excessive load of auger mixer	Load smaller portions of material into the tank
	Mechanical damage	Repair the gear.
Too low rotation speed of auger mixer	Excessive load of auger mixer	Load smaller portions of material into the tank
	Damaged overload clutch in the mixer feeder's drive system	Repair the clutch or change the shaft.
	Damaged planetary gear or two-speed reduction gear	Repair the gear.
	Wrong setting of the two-speed reduction gear speed	Check the position of the transmission speed change lever

# NOTES

A series of horizontal dotted lines for writing notes.



# ANNEX A

Half axle wheels

TYRES	WHEEL DISC
30x11.5-14.5, load-bearing capacity 156 A5	10.00x14.5A; ET=0