



PRONAR SP. Z O.O.

17-210 NAREW, UL. MICKIEWICZA 101A, WOJ. PODLASKIE

USER MANUAL

AGRICULTURAL TRAILER PRONAR TD218

TRANSLATION OF THE ORIGINAL MANUAL

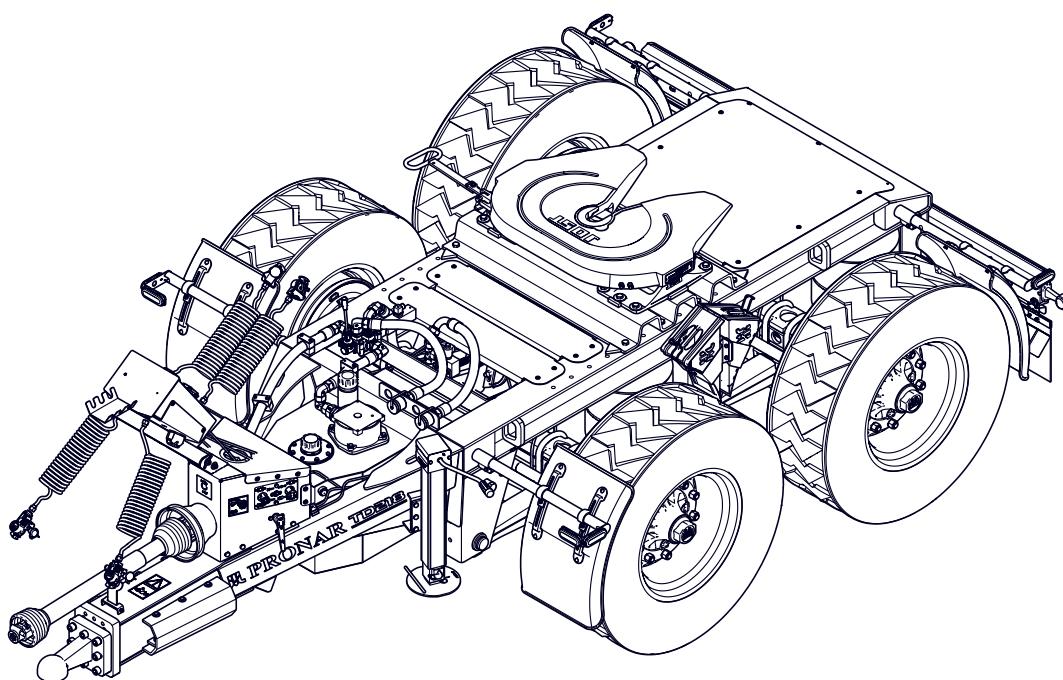

ISSUE 1A

03-2022

EDITION NO. 637.01.UM.1A.EN



Manufacturer's address

PRONAR Sp. z o.o.
ul. Mickiewicza 101A
17-210 Narew

Contact phones

+48 085 681 63 29
+48 085 681 64 29
+48 085 681 63 81
+48 085 681 63 82

Website

www.pronar.pl
<https://pronar-recycling.com/pl/>

Service hotline

+48 085 682 71 14
+48 085 682 71 93
+48 085 682 71 20
serwis@pronar.pl

This manual contains important safety and operating instructions for the machine. The manual should be kept near the machine so that it is accessible to persons authorized to operate it.

Keep this manual for future reference. If the manual is lost or damaged, contact the seller or the manufacturer for a duplicate.

Copyright © PRONAR Sp. z o.o. All rights reserved.

This study is the property of PRONAR Sp. z o.o. and is a work within the meaning of the Copyright and Related Rights Act.

Any part of this document may not be distributed or copied in any way (electronic, mechanical or otherwise) without the written consent of PRONAR Sp. z o.o.

Table of content

CHAPTER 1	
INTRODUCTION	1.1
1.1 Dear User.....	1.2
1.2 Target group.....	1.4
1.2.1 End user (User, Authorized User, Operator).....	1.4
1.2.2 Qualified person (qualified personnel).....	1.5
1.2.3 Service personnel.....	1.5
1.2.4 Unauthorized user.....	1.6
1.3 Rules for using the User's Manual.....	1.7
1.4 Symbols and tags used in the manual.....	1.8
1.4.1 Danger.....	1.8
1.4.2 Caution.....	1.8
1.4.3 Advice.....	1.8
1.4.4 Typography of the User Manual.....	1.9
1.5 Glossary.....	1.11
1.6 Personal protective equipment.....	1.13
1.6.1 General.....	1.13
1.6.2 Work clothing.....	1.13
1.6.3 Hearing protectors.....	1.13
1.6.4 Work shoes.....	1.14
1.6.5 Warning vest.....	1.14
1.6.6 Protective gloves.....	1.14
1.6.7 Safety glasses with side shields.....	1.15
1.6.8 Industrial protective helmet.....	1.15
1.6.9 Anti-dust respirator.....	1.15
CHAPTER 2	
GENERAL	2.1
2.1 Identification.....	2.2
2.1.1 Machine identification.....	2.2
2.2 Intended use of the machine.....	2.6
2.2.1 Use for the intended purpose.....	2.6
2.2.2 Expected misuse	2.7
2.3 Agricultural tractor requirements.....	2.9
2.4 Trailer equipment	2.10
2.5 Transport.....	2.11
2.5.1 Trucking.....	2.11
2.5.2 User's transport.....	2.12

2.6	Terms of warranty.....	2.14
2.7	Threat to the environment.....	2.15
2.8	Withdrawal from use.....	2.16

CHAPTER 3

SAFETY OF USE.....	3.1	
3.1	Basic safety rules.....	3.2
3.2	Fire hazard.....	3.4
3.3	Safety during coupling of the machine.....	3.5
3.4	Safety when operating the hydraulic and pneumatic systems.....	3.7
3.5	Principles of safe maintenance.....	3.8
3.6	Driving on public roads.....	3.11
3.7	Description of residual risk.....	3.14
3.8	Information and warning stickers.....	3.15
3.9	Working with the machine with the power take-off (PTO).....	3.18
3.10	Safety when handling the fifth wheel.....	3.20

CHAPTER 4

CONSTRUCTION AND PRINCIPLE OF OPERATION.....	4.1	
4.1	Technical characteristics.....	4.2
4.2	Construction of a trailer.....	4.4
4.3	Pneumatic installation.....	4.6
4.3.1	Brake pneumatic system.....	4.6
4.3.2	Pneumatic suspension.....	4.7
4.3.3	Loosening-parking valve.....	4.7
4.3.4	Pneumatic connections.....	4.8
4.3.5	ABS function.....	4.8
4.4	The hydraulic system.....	4.9
4.5	Electrical system.....	4.10

CHAPTER 5

RULES OF USE.....	5.1	
5.1	Mechanical support.....	5.2
5.2	Service of the folding hydraulic support.....	5.4
5.3	Connecting and disconnecting of the trailer.....	5.6
5.3.1	Connecting of the trailer.....	5.6
5.3.2	Disconnecting the trailer.....	5.10
5.3.3	Parking brake.....	5.10
5.4	Fifth wheel handling.....	5.13
5.5	Transport.....	5.17
5.6	Use of tires.....	5.20

5.7	Cleaning.....	5.22
5.8	Storage.....	5.24

CHAPTER 6

PERIODIC INSPECTIONS AND TECHNICAL MAINTENANCE		6.1
6.1	General.....	6.2
6.2	Entering and staying in high-risk areas.....	6.3
6.3	Maintenance and inspection schedule.....	6.4
6.4	Checking of the trailer before driving	6.7
6.5	Air reservoir draining.....	6.9
6.6	Checking plugs and connection sockets.....	6.10
6.7	Measurement of air pressure, check tires and wheels.....	6.12
6.8	Cleaning the air filters.....	6.14
6.9	Checking brake lining wear.....	6.15
6.10	Checking the clearance of the axle bearings.....	6.16
6.11	Checking of mechanical brakes.....	6.18
6.12	Cleaning of the drainage valve.....	6.20
6.13	Checking the tightness of the hydraulic system.....	6.21
6.14	Checking and topping up of hydraulic oil.....	6.23
6.15	Hydraulic oil replacement.....	6.24
6.16	Hydraulic system filters replacement.....	6.26
6.17	Control of pneumatic braking system.....	6.27
6.18	Tightening torques for screw connections.....	6.28
6.19	Tightening road wheels.....	6.30
6.20	Tightening of the drawbar eye.....	6.32
6.21	Replacement of hydraulic hoses.....	6.33
6.22	Pneumatic suspension control.....	6.34
6.23	Adjusting the clearance of the axle bearings.....	6.36
6.24	Brake adjustment.....	6.38
6.25	Electrical system service and warning elements.....	6.43
6.26	Lubrication.....	6.44
6.27	Consumables.....	6.47
6.27.1	Hydraulic oil.....	6.47
6.27.2	Lubricants.....	6.48
6.27.3	List of consumables for the machine.....	6.49
6.28	Wheel installation and removal.....	6.50
6.29	Tires.....	6.52
6.30	Faults and methods to remove them.....	6.53



PRONAR Sp. z o.o.
ul. Mickiewicza 101 A
17-210 Narew, Polska
tel./fax (+48 85) 681 71 00,
fax (+48 85) 681 63 83
<http://www.pronar.pl>
e-mail: pronar@pronar.pl



EC Declaration of Conformity

PRONAR Sp. z o.o. declares, with full responsibility, that the machine:

Machine description and identification data	
General description and purpose:	AGRICULTURAL TRAILER
Type:	TD02
Model:	TD218
VIN number:	
Commercial name:	agricultural trailer PRONAR TD218 or trailer PRONAR TD218 or agricultural trailer TD218 or trailer TD218 or PRONAR TD218 or TD218 or Agricultural trailer PRONAR TD218 dolly or trailer PRONAR TD218 dolly or agricultural trailer TD218 dolly or trailer TD218 dolly or PRONAR TD218 dolly or TD218 dolly

referred to in this declaration meets the requirements of the Directive **2006/42/EC** of The European Parliament and of The Council of 17 May 2006 on machinery.

The machine has been designed for and meets the requirements of the following standards:

PN-EN ISO 12100, PN-EN 1853, PN-EN ISO 4254-1

This declaration applies exclusively to the machine in the condition, in which it was sold and does not include components or parts added or subsequent modifications made by the final user.

The operator's manual is an integral part of the machine.

The Implementation Department Manager of PRONAR Sp. z o.o., 17-210 Narew, ul. Mickiewicza 101A is authorised to provide the technical documentation.

PRONAR Spółka z o.o.
17-210 Narew ul. Mickiewicza 101A
Tel. (85) 681 63 29, 682 72 54
Fax: (85) 681 63 83
NIP 543-02-00-939, KRS 0000139188
BDO 000014169

Z-CIA DYREKTORA
d/s technicznych
czynności zarządku

Roman [Signature]

Narew, on 2022-02-25

Date and place issued

*Full name of the authorised person,
position, signature*

CHAPTER 1

INTRODUCTION

PRONAR TD218

1.1 DEAR USER

The manual instruction is intended for the end user. For this reason, some required maintenance is listed in the inspection tables but the procedure is not described in this publication. To perform them, call the manufacturer's authorized service center.

Before starting the machine, you will be familiarized with its construction, principle of operation, available equipment and operation, and above all safety rules. The operator and qualified personnel should be trained during final reception.

Remember!!! You can run the machine only when you have read the content of this "User Manual", you have been trained and you can handle it safely. In case of any doubts, contact the seller to clarify the problem.

The most important thing during operation is your safety, therefore, regardless of everything, all recommendations contained in the "User's Manual" should be observed and guided by reasonable procedure. Remember that the correct service, in accordance with the manufacturer's instructions, reduces the risk of an accident to a minimum, and working with the machine is more efficient and less emergency.

When buying machines, check the compatibility of serial numbers placed on the machine with the number entered in the "Warranty card" and in the sales documents. For information on identifying the machine, see "Basic information" chapter. We recommend that you have the most important serial numbers entered the field below.

Machine serial number:

--	--	--	--	--	--	--	--	--	--	--	--	--	--	--	--	--

WST.3.B-001.01.EN

1.2 TARGET GROUP

The User Manual is intended for staff operating the machine called end users, and qualified persons (electrician, mechanic, plumber). Detailed information on the competences and liability of end users and qualified personnel can be found later in this chapter.

1.2.1 End user (User, Authorized User, Operator)

Who is the end user?

An end user, otherwise known as the user or operator, call the person authorized to operate the machine. The user can be authorized to handle the machine if the following conditions have been met.

- The user has familiarized with the content of the "User's Manual".
- He gets acquainted with the contents of the farm tractor instruction manual and observes its recommendations.
- He complies with road traffic regulations and transport regulations in force in the country in which the machine is used,
- He has been trained in terms of compliance with established maintenance and regulation plans.
- He has authorizations to drive vehicles (vehicle assemblies) required in the country of use.

Responsibilities and permissions

The user acquired by the user allows for safe handling of the machine. In unforeseen cases, the user should follow a reasonable procedure and take care of their safety, people located near a working machine and other traffic users.

The knowledge and skills are entitled to the end user to handle the machine, carry out maintenance and repair or adjustment procedures in the scope specified by the manufacturer.

1.2.2 Qualified person (qualified personnel)

Who is a qualified person?

We call a qualified person any person admitted to perform some maintenance, repair or regulatory work in the scope specified by the machine manufacturer and who gained appropriate technical education in a specific profession and confirmed by the relevant document, completed the training carried out by the authorized manufacturer's or seller staff, can see threats and counteract them. Professional experience and professional skills entitle a qualified person to carry out some repairs of the machine and perform basic maintenance procedures in the scope provided by the manufacturer. A qualified person in addition to the necessary knowledge has the skills to use the specialized accessories necessary to perform the obligations. The following persons include qualified persons:

- Qualified mechanic.
- Qualified electrician.
- Qualified plumber.

1.2.3 Service personnel

Who is the service personnel?

Service personnel, otherwise known as the manufacturer's service or service, is a person or a group of qualified persons who have a much greater experience and knowledge to perform certain corrective and maintenance activities than qualified personnel. It has the right tools necessary to carry out work. The manufacturer's service has the required permissions and is a representative of a machine manufacturer or other equipment.

1.2.4 Unauthorized user

Who is an unauthorized user?

An unauthorized user also known as a bystander is a person who has not been trained by the manufacturer or an authorized seller, has not been familiarized with the basic issues of security, knowledge of the machine, did not familiarize with the entire content of the operating instructions, and therefore there are no authorizations to operate the machine. A bystander can not be admitted to work with the machine.

WST.3.B-003.01.EN

1.3 RULES FOR USING THE USER'S MANUAL

The information contained in the publication is current as at the date of publication. As a result of improvement, some sizes and illustrations contained in this publication may not correspond to the actual state of the machine delivered to the user.

The drawings contained in this publication are aimed at clarifying the principle of machine operation and may differ from the facts. This can not be a reason for any claims for this. The manufacturer reserves the right to introduce constructional changes in the manufactured machines to facilitate operation and improve the quality of their work, without making any current changes to this publication.

The operating instruction is the basic equipment of the machine. If the information contained in this study prove not fully understandable to ask for aid to the point of sale in which the machine has been purchased or directly to the manufacturer.

The machine was constructed in accordance with applicable standards, documents and current legal regulations.

Separate studies can be attached to this manual that can be found in the chapter "Attachments and additional materials".

WST.3.B-002.01.EN

1.4 SYMBOLS AND TAGS USED IN THE MANUAL

1.4.1 Danger

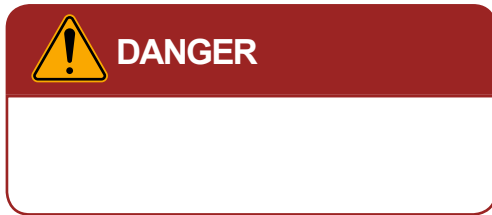

Information, descriptions of hazards and precautions as well as instructions and orders related to the safety of use in the content of the manual are marked with a frame with the word **DANGER**. Failure to comply with these recommendations may endanger the health or life of persons operating the machine or bystanders.

1.4.2 Caution



Particularly important information and recommendations, the observance of which is absolutely necessary, are highlighted in the text with a frame and word **CAUTION**. Failure to comply with these recommendations creates the risk of damage to the machine due to improper handling, adjustment or use.

1.4.3 Advice



Additional instructions contained in the manual describe useful information on operating the machine and are marked with a frame with the word **ADVICE**.

1.4.4 Typography of the User Manual

Bulleted list

The bulleted list presents actions to perform whose order is not relevant.

Example of using a bulleted list

-
- Check the condition of connections and hydraulic and pneumatic hoses. Hydraulic oil leaks and air defects from a leaky installation are unacceptable.
- In the event of a hydraulic or pneumatic installation failure, the shredder should be turned off from operation until the failure is removed.
-

Comment on the text

Comment is most often a supplement and additional explanation to order a specific activity. Additional information can also be included in the comment.

An example of a comment

Defined list

The required air pressure is described on the sticker placed on the machine frame, over the wheel.

List shows the to-do, whose execution order is important.

Example of using a defined list

1.
2. Unscrew the handles (2) securing the crank (1).
3. Insert the crank into a square shaft of the gear and turning the clock clockwise on the direction of the clock.
4.

References to pages

Reference to chapter (place in the manual) related thematically

An example of a reference application

 **page 9.4**

WST.3.B-004.01.EN

1.5 GLOSSARY

agricultural tractor

A motor vehicle constructed for use together with agricultural, forest or gardening equipment; such tractor can also be adapted for pulling trailers and for earthworks.

tractor

A car vehicle designed only to pull the trailer; This term includes a tractor and a ballast tractor.

Vehicle semi-trailer

Vehicle without drive intended for the transport of loads. It does not have a front axle, so part of the semi-trailer rests on a tractor unit or a trailer for transporting semi-trailers. The semi-trailer is connected by means of a fifth wheel coupling.

final acceptance

Group of activities associated with the preparation and actual transfer of the finished product for use. The final acceptance contains the transmission of documentation, basic training, reception for transport and the first launch of the machine.

bystander

See - an unauthorized user

qualified person

A person admitted to perform some maintenance, repair or regulatory work in the scope specified by the machine manufacturer and which has gained appropriate technical education in a specific profession and confirmed by the relevant document and completed the training carried out by the authorized manufacturer's or seller staff, can notice the threats and counteract them.

truck

A car vehicle designed structurally for carriage; This term also includes a cargo-passenger car designed for transporting loads and people in a number from 4

to 9 including the driver.

Danger zone

A dangerous zone is an area around the machine in which people who are vulnerable to the risk of losing health or life.

Three-point suspension system

A three-point suspension system - a lever system used in agricultural tractors for aggregation of machines and devices suspended on a hydraulic lifter.

End user

Otherwise known as the user, an authorized user or operator, the person authorized to operate the machine.

Unauthorized user

Also known as a bystander - person who has not been trained and has not been allowed to handle the machine.

PTO

Power reception shaft - transmitting a drive from the vehicle to the moving machine.

set (trailer + semi-trailer)

A trailer connected to a vehicle semi-trailer by means of a fifth wheel coupling.

WST.3.I-001.01.EN

1.6 PERSONAL PROTECTIVE EQUIPMENT

1.6.1 General



CAUTION

Personal protective equipment should be used in accordance with the recommendations of the security manufacturer.

Follow local regulations regarding personal protective equipment.

The personal protective equipment listed below is a minimum protection for the operator, qualified person or service personnel against the effects of unfavorable external factors and is only a recommendation for use.

We recommend carrying out a risk assessment at the machine's workplace and adjusting the personal protective equipment depending on the actual working conditions.

1.6.2 Work clothing



Work clothing should fit the operator's body correctly. The material from which the clothing is made should be characterized by high tear strength. Clothing must not have any protruding elements that may be accidentally caught by the mechanisms of the machine.

1.6.3 Hearing protectors



It is recommended to use of ear muffs for use with a protective industrial helmet for hearing protection. The selection of the attenuation value should be selected individually depending on the noise level. Remember to properly store and maintain your hearing protectors. Poorly stored and maintained hearing protectors lose their protective properties over time. Periodically replace the soundproofing cushions according to the manufacturer's recommendations.

1.6.4 Work shoes



Work shoes should have the following properties:

- non-slip sole,
- sole material made of a material resistant to oils, gasoline and other organic solvents.
- toe cap resistant to impact with an energy of 200 J,
- insert securing the foot against piercing of the sole.

The above properties correspond to the S3 shoe category according to PN-EN ISO 20345.

1.6.5 Warning vest



The warning (reflective) vest is designed to increase the operator's visibility to other users. Instead of a reflective vest, you may wear work clothes that meet the requirements of EN471. It is recommended that the warning vest (or work clothing) be class 2.

1.6.6 Protective gloves



Protective gloves should be selected depending on the currently performed work.

Strong protective gloves

Strong protective gloves for hand protection are used for protection during heavy work such as cleaning the machine, removing clogs and the like, where there is a risk of damaging the hands. Protective gloves should protect the hands from cuts, scratches, abrasions, punctures and similar injuries to the skin and against light burns in contact with hot surfaces.

Light protective gloves

For light work (general operation, minor maintenance etc.), we recommend using light protective gloves for work in a dry or slightly oily environment. The working surface of the gloves (internal part) should be covered with an impermeable material, e.g. nitrile.

Nitrile gloves

Nitrile gloves designed for working with urea, fuel or lubricants. They are designed for light work where there is a risk of skin contact with lubricants, fuel, urea, gear oil and hydraulic oil.

1.6.7 Safety glasses with side shields

Safety glasses to protect the eyes against contact with hazardous substances, splashing liquids or dust and airborne dust. Safety glasses with side shields increase the level of protection.

1.6.8 Industrial protective helmet

The industrial protective helmet is designed to protect the head against injuries. The design of the helmet should be in accordance with the EN397 standard. The protective helmet must fit correctly to the anatomical shape of the skull. There are adjustment straps for this purpose. The helmet has a limited shelf life. After this date, the material from which it was made loses its properties and does not fulfil the assumed task. The helmet must be replaced.

1.6.9 Anti-dust respirator

It is recommended to use disposable respirators with



CAUTION

Remember that personal protective equipment should be regularly maintained and used in accordance with the recommendations of the product manufacturer. Following these guidelines will ensure safe use and the best protection.

an exhalation valve to protect the respiratory tract. The size of the mask should match the operator's face. The mask should fit snugly against the skin. The nasal part should be adjusted using the adjustment plate. Remember that facial hair can make it difficult to seal the face mask. The half mask should be adapted to the type of material being processed.

Minimum half mask recommendations:

- type FFP1, in accordance with EN-149: 2001 + A1: 2009, protection against non-toxic liquid or solid aerosols,
- P1 class.

WST.3.I-002.01.EN

CHAPTER 2

GENERAL

PRONAR TD218

2.1 IDENTIFICATION

2.1.1 Machine identification



ADVICE

You should require the seller to carefully fill out the Warranty Card and complaint coupons. The lack of e.g. date of sale or point of sale stamp exposes the user to not accept any complaints.

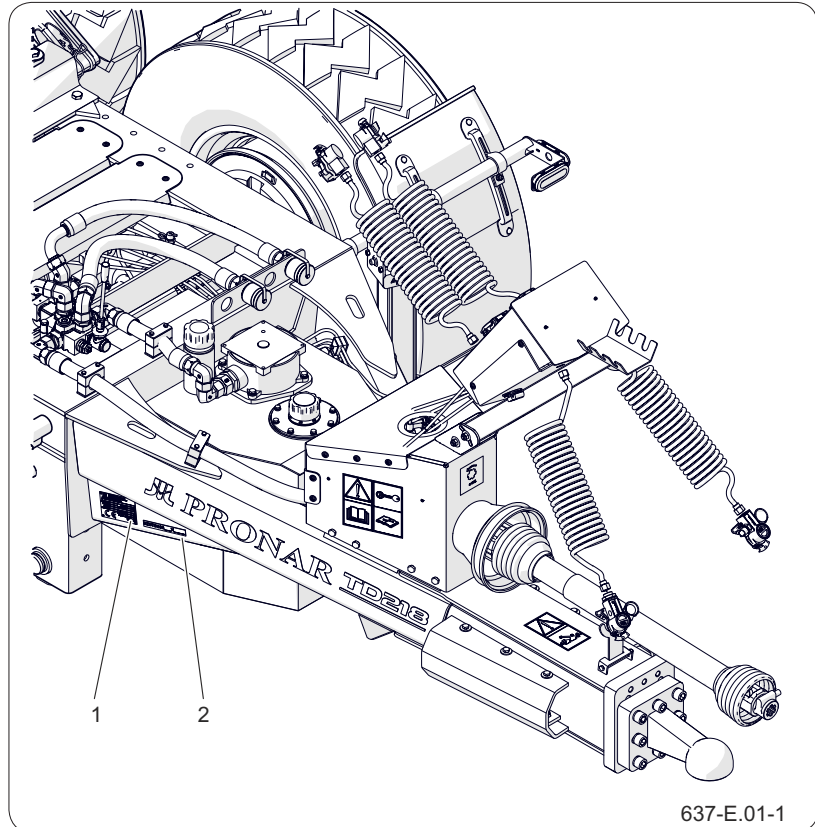

Figure 2.1 Identification of trailer

(1) name plate

(2) trailer VIN number location

The trailer is marked with the name plate (1) and the serial number (2) placed on the highlighted rectangular field on the trailer frame. The serial number and the name plate are as shown in the "Trailer identification" figure

When purchasing the trial, check that the serial numbers on the machine match the number entered in the WARRANTY CARD, in the sales documents and in the USER MANUAL. The meaning of the individual fields on the nameplate is shown in the table. Record the trailer's serial number in the top field.

Table 2.1. Nameplate markings

Item	Meaning
A	General information and function
B	Trailer symbol / type
C	Year of production
D	VIN number
E	Approval certificate number
F	Karb weight
G	Permissible total weight
H	Loading capacity
I	Permissible load on the coupling
J	Permissible load for individual axles

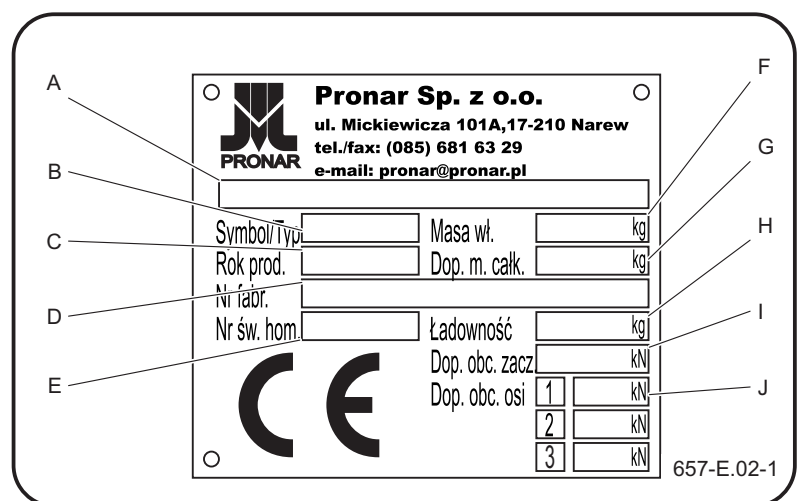

Figure 2.2 Name plate

Driving axle identification

The serial number of the driving axles and their type is stamped on the name plate (2) attached to the driving axle profile - figure "Axis identification". After purchasing the trailer, it is recommended to enter the individual serial numbers in the fields below.

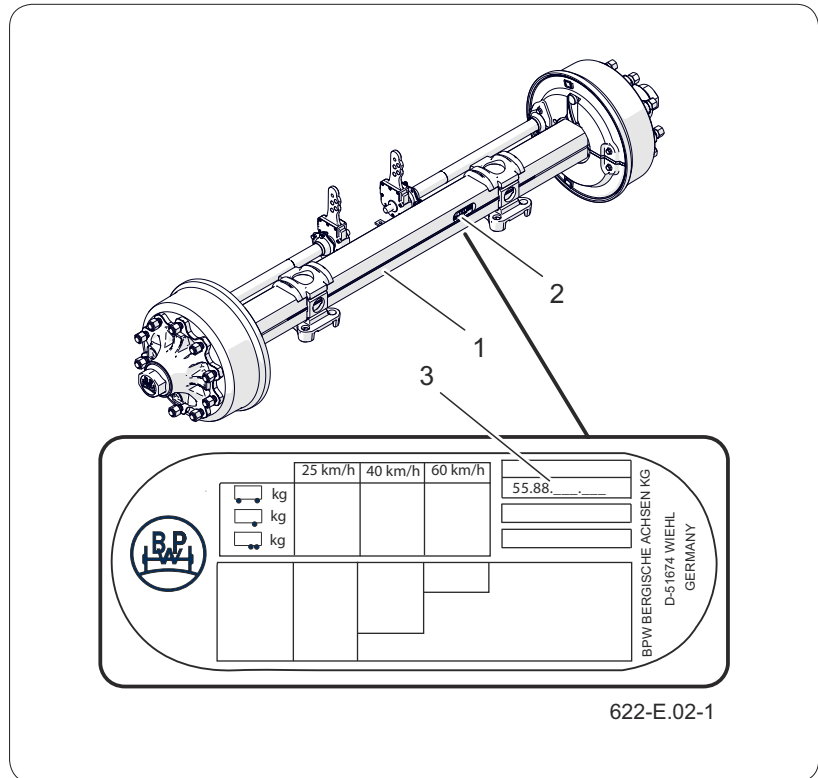

Figure 2.3 Axle identification
 (1) driving axle (2) name plate
 (3) axle serial number

Saddle identification

The fifth wheel's serial number is stamped on the data plate and also under the data plate.

After purchasing the trailer, it is recommended to enter the individual serial numbers in the fields below.

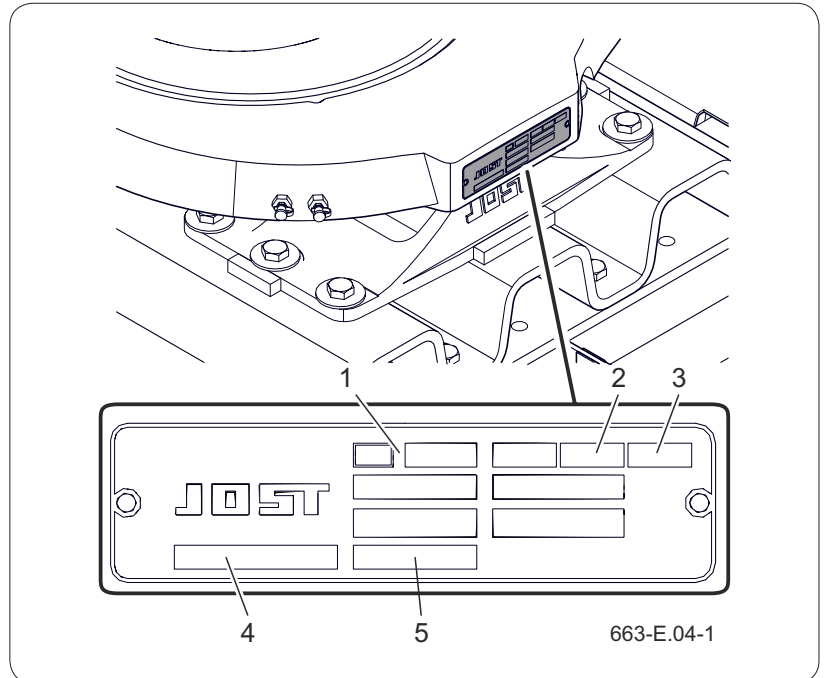

Figure 2.4 Saddle identification

Table 2.2. Sattel nameplate markings

Item	Meaning
1	EC approval number
2	Permissible value of D in kN
3	Permissible vertical U load in t
4	Item no. and type
5	Serial number

INF.3.I-005.11.EN

2.2 INTENDED USE OF THE MACHINE

2.2.1 Use for the intended purpose



DANGER

The machine may not be used for purposes other than those for which it is intended.

The trailer is designed for transporting semi-trailers within the farm, with the use of a farm tractor. Transport on public roads is possible provided that the regulations in force in the country in which the trailer is used allow for the set to be used.

Failure to comply with the instructions for transporting the set (trailer + semi-trailer) and loading the goods specified by the Manufacturer and the road transport regulations in force in the country in which the trailer is used, will invalidate the warranty services and is considered as using the machine contrary to its intended use.

The set is not intended for the transport of people, animals and goods classified as hazardous materials.

The braking system as well as the lighting and signalling system meet the requirements arising from traffic regulations.

In the countries where the trailer is used, the limits stipulated by the road traffic law in force in a given country must be observed.

The trailer speed cannot exceed the maximum design speed of 40 km/h.

Intended use also includes all activities related to the correct and safe operation and maintenance of the machine. Therefore, the user is obliged to:

- read the content of trailer's *USER MANUAL* and with *WARRANTY CARD* and to the guidelines contained in these documents,
- understand the principle of machine operation and the safe and proper operation of the trailer,
- act in compliance with established maintenance and adjustment plans,
- work in compliance with general safety regulations,

- accident prevention,
- comply with road traffic regulations and transport regulations in force in the country in which the machine is used,
- become familiar with the content of the tractor unit operator's manual and follow its recommendations,
- couple the vehicle only with such an agricultural tractor that meets all the requirements set by the trailer Manufacturer.
- couple the vehicle only with a semi-trailer that meets all the requirements set by the trailer manufacturer.

The trailer may only be used by persons who:

- become familiar with the contents of publications and documents attached to the trailer and the contents of manual of agricultural tractor,
- have been trained in the use of the trailer and work safety,
- have the required driving license and are familiar with the road traffic regulations and transport regulations.

2.2.2 Expected misuse

The expected improper use of the machine is related primarily to the transport of materials that do not comply with the manufacturer's recommendations, for example:

- transport of people, animals,
- transport of incorrectly secured cargo, which could change its position in the load box during driving,
- transport of cargo that location of the centre of gravity adversely affects the stability of the trailer,
- carrying a load that affects the uneven load and/or overload of the driving axles and suspension elements,

- sudden lowering and jerking of the trailer.

An employee who has not been trained in the field of operation and safety at work, does not have appropriate qualifications and the required skills cannot be allowed to operate the machine.

When operating the machine, it is strictly forbidden to:

- stay in the danger zone,
- climb onto the machine while it is working,
- make any unauthorized design changes,
- repairs and service by unauthorized and unqualified personnel.

INF.3.I-001.01.EN

2.3 AGRICULTURAL TRACTOR REQUIREMENTS

Table 2.3. Agricultural tractor requirements

Content	Unit	Requirements
Brake installation		
Pneumatic 2 - line	-	Sockets in accordance with ISO 1728
Maximum pressure of the system	bar/kPa	8 / 800
Electrical system		
Connection of electrical installation	V	12
Connection socket	-	7-pole according to ISO 1724
Connection socket	-	3-pole
Cigarette lighter socket	V	12
Tractor hitches		
Type of hitch	-	Upper, lower transport hitch
Minimum vertical load capacity of the hitch	kg	4,000
Rear power take-off (PTO)		
Type	-	Type 1 (1 3/8") according to ISO 730-1
Rotational speed	rpm	540
Number of splines on the shaft	pcs	6
Rotation direction	-	clockwise
Other requirements		
Minimum tractor power requirement	kW/HP	133.8 / 182

INF.3.I-002.01.EN

2.4 TRAILER EQUIPMENT

Table 2.4. Trailer equipment ¹

Content	Standard	ADDITIONAL	Optional
User manual	•		
Warranty Card	•		
Manual for assembly and use of the fifth wheel		•	
PTO shaft (460Nm; L860)	•		
7P spiral cable for electrical installation	•		
3P connection cable of the electrical system	•		
Electric lighting system 12V (LED)	•		
Wheel chocks	•		
Mechanical drawbar support	•		
Hydraulic, foldable drawbar support			•
Coupling fifth wheel - longitudinally adjustable	•		
Integral hydraulic system with PTO driven pump and its own oil reservoir	•		
Rotating drawbar Ø50 mm	•		
Rigid drawbar eye Ø40 mm or Ø50 mm or ball drawbar K80			•
Pneumatic suspension	•		
Braking system: two-conduit, pneumatic with ALB	•		
Automatic parking brake	•		
Plastic fenders	•		
Wide plastic fenders			•
Rear protection	•		
Converter for powering of the ABS system of a car trailer	•		
The triangle distinguishing slow-moving vehicles		•	

(1) - Some standard equipment items that are listed in the table may not be included in the supplied trailer. This is due to the possibility of ordering a new machine with a different set - optional equipment, replacing the standard equipment.

Tire information is provided at the end of the publication in TIRES chapter.

2.5 TRANSPORT

The machine is ready for sale completely assembled and does not require packing. Only the machine's technical documentation and any additional equipment elements are packed. Delivery to the user is carried out by road or independent transport (towing of the trailer with an agricultural tractor).

2.5.1 Trucking



DANGER

During road transport, the trailer must be mounted on the platform of the vehicle in accordance with safety requirements and regulations.

The driver of the car should exercise particular care while driving. This is due to the vehicle's centre of gravity shifting upwards with the machine loaded.

Use only approved and technically reliable securing measures. Read the operating instructions of the securing measures manufacturer.

Incorrect application of securing measures may cause an accident.

Loading and unloading of a trailer from a car should be carried out using a loading ramp with a farm tractor. During work act in compliance with the general principles of workplace health and safety for reloading work. Persons operating reloading equipment must have the required permissions to use these devices. The machine must be correctly connected to the tractor in accordance with the requirements of this manual. The trailer braking system must be started and checked before driving off or onto the ramp. The machine should be attached firmly to the platform of the vehicle using straps, chains, lashings or other fastening devices equipped with a tensioning

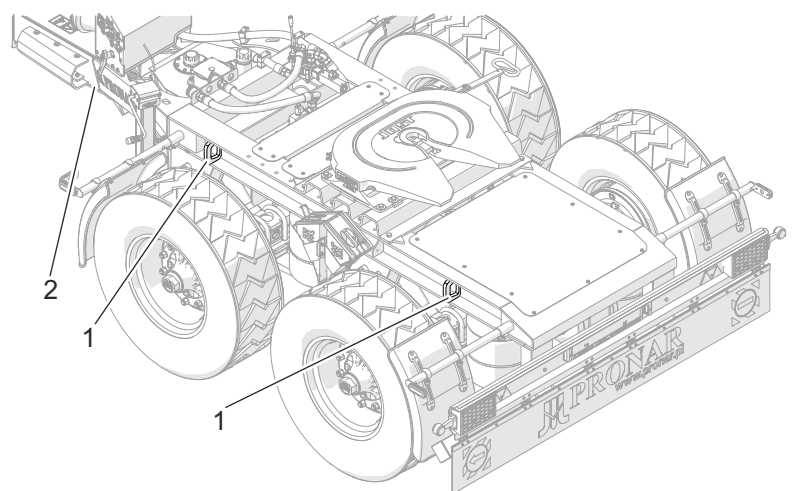

637-E.02-1

Figure 2.5 Trailer attachment points
(1) handle (2) frame



CAUTION

It is forbidden to attach slings and any kind of fastening elements to the elements of the hydraulic system, electric system and fragile elements of the machine (e.g. covers, wires).

mechanism. Attach the securing elements to the intended transport lugs (1).

Chocks or other elements without sharp edges should be placed under the trailer wheels, protecting the machine against rolling. The wheel must be secured to the vehicle loading platform in such a way that it cannot move.

Use certified and technically efficient securing measures. Worn straps, cracked fasteners, bent or corroded hooks or other damage may disqualify the agent from use. Familiarize yourself with the information contained in the operating instructions of the manufacturer of the securing agent used. The number of fastening elements (ropes, belts, chains, lashings, etc.) and the force needed to tension them depend, among others, on the weight of the machine's own, the structure of the transporting car, travel speed and other conditions. Therefore, it is not possible to specify the fastening plan in detail.

In order to correct attach the trailer to the loading platform, support the drawbar by placing a support in the form of a wooden block under it. A properly attached trailer will not change its position relative to the transporting vehicle. The fastening means must be selected in accordance with the guidelines of the manufacturer of these elements. In case of doubt, a larger number of attachment and securing points for the trailer should be used. If necessary, protect the sharp edges of the trailer, thus securing the securing measures against damage during transport.

During reloading work, pay special attention not to damage elements of the machine equipment and the paint coating.

2.5.2 User's transport

If the user decides to transport the trailer independently after purchasing the trailer, read the trailer



CAUTION

When transporting independently, as an operator, read the contents of this User's Manual and follow the recommendations contained therein.

Operator's Manual and follow its recommendations. Independent transport involves towing a trailer with own agricultural tractor to its destination. While driving, adjust the speed to the prevailing road conditions, but it must not be greater than the maximum design speed.

INF.3.I-004.11.EN

2.6 TERMS OF WARRANTY

ADVICE

You should require the seller to carefully fill out the Warranty Card and complaint coupons. The lack of e.g. date of sale or point of sale stamp exposes the user to not accept any complaints.

PRONAR Sp. z o.o. in Narew guarantees easy operation of the machine when it is used in accordance with the technical and operational conditions described in the USER MANUAL. Deadline for completion of repairs is specified in the Warranty Card.

The warranty does not apply to parts and sub-assemblies of the machine, which are subject to wear in normal operating conditions, regardless of the warranty period.

The warranty services only apply to such cases as: mechanical damage not caused by the fault of the user, factory defects of parts, etc.

In the event that damage occurs as a result of:

- mechanical damage caused by the user's fault, road accident,
- from improper operation, adjustment and maintenance, use contrary to its purpose,
- use of a damaged machine,
- repairs carried out by unauthorized persons, improper repairs,
- execution of user changes in machine design,

the user loses the warranty.

The user is obliged to immediately report all noticed defects in the paint coatings or traces of corrosion, and order removal of defects regardless of whether the damage is covered by the warranty or not.

Detailed warranty conditions are given in the WARRANTY CARD attached to the newly purchased machine.

Modifications to the machine without the written consent of the Manufacturer are prohibited. In particular, welding, reaming, cutting and heating of the main machine components that directly affect safety during use are not permitted.

INF.3.B-006.01.EN

2.7 THREAT TO THE ENVIRONMENT

ADVICE

The trailer's hydraulic system is filled with L-HL 32 Lotos oil.



DANGER

Do not store oil waste in food containers.

Store used oil in containers resistant to hydrocarbons.



CAUTION

Oil waste can only be delivered to a point dealing with the utilization or regeneration of oils. It is prohibited to throw or pour oil into the sewage system or water reservoirs.

A hydraulic oil leak is a direct threat to the natural environment owing to its limited biodegradability. Repair works with a risk of leakage of oil, should be carried out in rooms with an oil resistant surface. In the event of oil leaking into the environment, first of all contain the source of the leak, and then collect the leaked oil using available means. Collect oil residue with sorbents or mix the oil with sand, sawdust or other absorbent materials. Collected oil contaminants should be stored in an airtight and marked container, resistant to hydrocarbons, and then transferred to an oil waste disposal point. The container should be kept away from heat sources, flammable materials and food. Oil which has been used up or is unsuitable for further use due to the loss of its properties is recommended to be stored in its original packaging in the same conditions as described previously. Waste code 13 01 10 (hydraulic oil). Detailed information on oil can be found in the product safety data sheet.

INF.3.B-007.01.EN

2.8 WITHDRAWAL FROM USE



DANGER

Before commencing dismantling, reduce residual pressure in pneumatic and hydraulic systems.

Avoid oil contact with skin. Do not allow oil to leak.

Before starting to disassemble the gas accumulator, the accumulator pressure must be relieved on both the liquid and gas side.

In the event of decision by the user to withdraw the machine from use, comply with the regulations on withdrawal from use and recycling of machines withdrawn from use in force in a given country.

During dismantling, use appropriate tools and equipment (overhead cranes, elevators, lifts, etc.) and use personal protective equipment, i.e. protective clothing, footwear, gloves, glasses, etc.

Works related to the disassembly of the hydraulic system should be performed by suitably qualified personnel.

Before proceeding to dismantling, reduce the residual pressure in the hydraulic system, drain the oil completely. Remove all air from the pneumatic system of the machine by draining the air reservoir.

In the event of replacement of parts, take the worn or damaged elements to a collection point for recyclable materials. Take used oil as well as rubber or plastic elements to plants dealing with the utilization of this type of waste.

Table 2.5. Codes of waste generated by dismantling of the machine

Item	Code	Meaning
1	07 02 13	Plastic waste
2	13 01 10	Other hydraulic oils
3	13 02 04*	Mineral engine, gear and lubricating oils containing halogenated organic compounds
4	13 02 06*	Synthetic engine, gear and lubricating oils
5	13 02 08*	Other engine, gear and lubricating oils
6	13 05 02*	Sludges from oil dewatering in separators
7	13 05 08*	A mixture of sand trap waste and oil dewatering in separators
8	15 01 10*	Packaging containing residues of or contaminated by hazardous substances
9	15 02 02*	Sorbents, filter materials and protective clothing contaminated with hazardous substances
10	16 01 03	Worn tires
11	17 04 05	Iron and steel
12	17 04 11	Cables other than those mentioned in 17 04 10

INF.3.8-008.01.EN

CHAPTER 3

SAFETY OF USE

PRONAR TD218

3.1 BASIC SAFETY RULES



CAUTION

The trailer may only be used and operated by **persons qualified** to drive agricultural tractors with a trailer.

- Before using the trailer, carefully read the content of this publication and the „*Warranty Card*“. During operation, follow all recommendations.
- The user manual should be available to the operator for all the time. Protect the manual from damage.
- If the information contained in the User's Manual is difficult to understand, contact a seller who runs an authorized technical service on behalf of the manufacturer, or contact the manufacturer directly.
- If you ignore the recommendations contained in these document, you create a threat to the health and life of bystanders and/or the machine operator.
- Use and operate the trailer carefully! By a careless work, you create a threat to the health and life of bystanders and/or the machine operator.
- You are obliged to familiarize yourself with the construction, operation principles and safe operation of the trailer.
- Familiarize yourself with all machine controls before starting work. Do not use the machine without knowing its function.
- Before each start-up of the trailer, check that it is properly prepared for work, first of all in terms of safety.
- There is a residual risk of threats, therefore the basic principle of using the trailer should be the application of the principles of safe use and sensible behaviour. Remember that your safety is the most important thing.
- It is forbidden to use the machine by persons who are not authorized to drive tractors, including children, people under the influence of

alcohol, drugs or other intoxicating substances, etc.

- The trailer may not be used for purposes other than those for which it was intended. Everyone who uses the trailer in a manner contrary to its intended use, thus takes full responsibility for all consequences arising from its use.
- Use of the machine for purposes other than envisaged by the Manufacturer is inconsistent with the intended use and may void the warranty.

BHP.3.B-001.01.EN

3.2 FIRE HAZARD

- Keep the trailer clean, which will allow you to reduce the risk of damage and reduce the risk e.g. due to fuel or oil leakage.
- Remember, oil spills, excess grease, and other contaminants increase the risk of a fire.
- If you notice fire or smoke, stop the trailer immediately. Notify the fire brigade and locate the source of fire or smoke as soon as possible and start extinguishing the fire using appropriate extinguishing agents depending on the material burning. Be especially careful.
- Read the information leaflets on the available extinguishing agents.
- Do not block access for fire guards.

BHP.3.I-007.01.EN

3.3 SAFETY DURING COUPLING OF THE MACHINE



CAUTION

Check the condition of mechanical coupling devices (e.g. rings). Deformed or damaged mechanical couplings should be replaced by service personnel.

- Do not connect the trailer to the tractor, if it does not meet the requirements set by the Manufacturer (minimum power demand of the tractor, inadequate connections, etc.) - see the section "*Tractor requirements*".
- It is forbidden to connect the trailer to the semi-trailer, if it does not meet the requirements set by the trailer Manufacturer.
- Before coupling of the trailer, make sure that both machines are technically sound.
- When connecting of the trailer to the tractor, use the the appropriate hitch of the tractor. After completing the coupling of the machines, check the coupling protection. Familiarize yourself with the content of the tractor operator's manual. If it is equipped with an automatic hitch, make sure the aggregation operation is complete.
- Be especially careful when connecting the

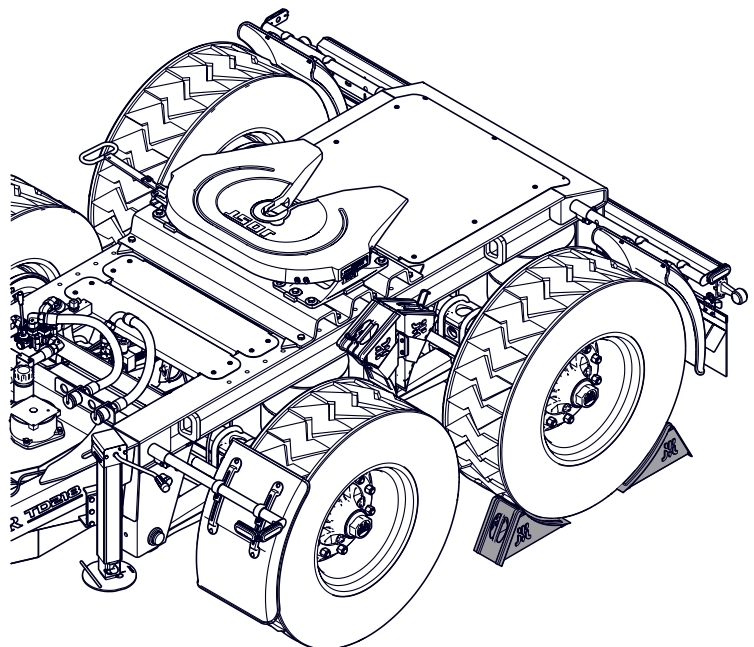

637-F.01-1

Figure 3.1 Position of the locking wedges
(1) support wedge



CAUTION

Place wedges only under the wheels of the rigid axle.

machine.

- When connecting the tractor to a trailer or a set (trailer + semi-trailer), it is forbidden for any person to stay between the two vehicles.
- You may couple and uncouple the trailer only when the machine is immobilized with the parking brake. If the trailer is standing on a slope or hill, additionally protect it against rolling by placing chocks or other elements without sharp edges under the wheels. Make sure that the wedges are on the trailer's equipment and are secured.
- Do not move the trailer when the support is extended and rests on the ground. While the machine is moving, there is a risk of damage to the support. After securing the hitch, raise the support maximally.

BHP.3.I-001.11.EN

3.4 SAFETY WHEN OPERATING THE HYDRAULIC AND PNEUMATIC SYSTEMS



DANGER

The hydraulic and pneumatic systems are under high pressure during operation.

- Regularly check the technical condition of the connections and the hydraulic and pneumatic lines. Trailer operation with a leaking system is forbidden.
- In the event of a failure of the hydraulic or pneumatic system, the trailer should be disconnected from use until the failure is remedied.
- When connecting the hydraulic hoses, make sure that the hydraulic system is not under pressure. If necessary, reduce the residual pressure in the installation. Refer „*Hydraulic system handling...*”.
- Use hydraulic oil recommended by the manufacturer.
- After changing the hydraulic oil, the used oil must be disposed of. Used oil or oil which has lost its properties should be stored in original containers or replacement packaging resistant to hydrocarbons. Replacement containers must be accurately described and properly stored.
- It is forbidden to store oil in packaging intended for food storage.
- Rubber hydraulic hoses should be replaced every 4 years regardless of their technical condition.

Procedure in the event of an accident

- In the event of injuries being caused by pressurized hydraulic oil, contact a doctor immediately. Hydraulic oil can penetrate the skin and cause infection.
- If the oil gets into the eyes, rinse with plenty of water and if irritation occurs, contact a doctor.
- In the event of contact of oil with skin wash the area of contact with water and soap. Do not use organic solvents (petrol, kerosene).

BHP.3.I-002.01.EN

3.5 PRINCIPLES OF SAFE MAINTENANCE

- Keep the trailer clean.
- You cannot transport people or animals with a trailer or a set (trailer + semi-trailer).
- It is forbidden to suddenly lower or jerk the semi-trailer during unloading (trailer + semi-trailer).
- It is forbidden to uncoupling of the semi-trailer with folded supporting legs. Uncoupling of the semi-trailer is allowed only with the front supporting legs of the vehicle supported.
- Keep a safe distance during loading and unloading. Keep bystanders away from the working area of the machine. The proximity of electric and telephone lines may also be a threat.
- Check how the load is distributed on the trailer. The load must be evenly distributed. A heavy load at the rear or front of the trailer may cause the trailer to tip over.
- During the warranty period, any repairs should be performed only by Warranty Service authorized by the manufacturer. After the end of the warranty period, it is recommended that any repairs shall be carried out by specialized workshops.
- Whenever you find any faults in operation or damage to the trailer, do not use it until it is repaired.
- During maintenance work, use appropriate, close-fitting protective clothing, gloves, shoes, glasses and the right tools.
- Any modifications to the trailer release the PRONAR Narew company from liability for any damage or health detriment.
- The trailer may only be entered when it is absolutely motionless and the tractor engine is turned off. Secure the set with the parking brake. Secure the tractor cabin against access by unauthorized

persons.

- Regularly check the technical condition of the safety devices and the correct tightening of the screw connections (in particular the drawbar eye and wheels).
- Carry out inspections of the trailer in accordance with the frequency specified in this manual.
- Before commencing repair works on hydraulic or pneumatic systems, reduce residual oil or air pressure completely. For the procedure see point: „*Hydraulic system handling...*” , „*Pneumatic system handling...*”
- Carry out repair, maintenance and cleaning works only with the tractor engine turned off and the ignition key removed. Secure the tractor and trailer with the parking brake and additionally place chocks under the trailer wheel. Secure the tractor cabin against access by unauthorized persons.
- Before commencing maintenance or repair work, secure the trailer with chocks and parking brake. Only a stationary trailer may be disconnected from the tractor.
- Should it be necessary to replace individual elements, use only the parts recommended by the Manufacturer. If you do not adhere to these requirements, you may put the user and other people's health and life at risk, and damage the machine and this is the basis for voiding the warranty.
- Before welding or electric works, disconnect the trailer from the power supply. Clean the paint coating. Burning paint fumes are poisonous to humans and animals. Perform welding work in a well-lit and ventilated room.
- During welding work pay attention to flammable or fusible elements (elements of pneumatic,

electric and hydraulic systems, elements made of plastics). If there is a risk that they will catch fire or be damaged, remove them or cover them with non-flammable material before welding. Before starting work, have a CO₂ fire extinguisher or foam extinguisher ready.

- In the event of work requiring the trailer to be raised, use properly certified hydraulic or mechanical lifts for this purpose. After lifting the machine use additional stable and durable supports. You cannot perform any work under the trailer, which has only been lifted with the jack.
- Do not support the trailer with fragile elements (bricks, hollow blocks, concrete blocks).
- After completing work connected with lubrication, remove excess oil or grease. Keep the trailer clean.
- You cannot repair elements of the hydraulic or pneumatic system yourself, i.e. control valves, actuators and regulators. In the event of damage to these elements, have them repaired at an authorized repair point or replace the elements with new ones.
- You may not install additional devices or accessories that do not comply with the specifications defined by the Manufacturer.
- You may tow the trailer only when the axle, lighting and braking systems are functional.

Procedure in the event of an accident

- Perform maintenance and repair activities applying the general principles of health and safety at work.
- In case of injury, wash and disinfect the wound immediately.
- If you experience more serious injury, seek medical advice.

3.6 DRIVING ON PUBLIC ROADS



CAUTION

Follow the road traffic regulations and transport regulations in force in the country in which the trailer is used.

- When driving on public roads, you must make sure that the trailer and tractor are equipped with a certified or approved reflective warning triangle.
- Before driving on public roads, place a triangular "*slow-moving vehicle*" plate (if the trailer is the last vehicle in the group).
- Before driving on the road, remove the tail light covers.
- When driving on public roads, comply with the road traffic regulations and transport regulations in force in the country in which the trailer is used.
- Do not exceed the maximum design speed 40 km/h. The driving speed must be adapted to the environmental conditions and the load. If possible avoid driving over rough terrain and unexpected turns.
- Never leave the machine unsecured. The trailer disconnected from the tractor must be immobilized with the parking brake and secured against rolling away with the use of wedges or other elements without sharp edges placed under the vehicle wheel.
- Before driving, make sure that the trailer is correctly attached to the tractor, especially that the hitch pins are secured.
- Before driving with the set (trailer + semi-trailer) make sure that the trailer is properly coupled with the semi-trailer and secured.
- Vertical load carried by the trailer drawbar eye affects the steering of the agricultural tractor.
- Before each use of the trailer, check its technical condition, especially in terms of safety. In particular, check the technical condition of the hitch system, chassis, braking system and light

signaling, as well as connection elements of the hydraulic, pneumatic and electrical systems.

- Before driving, check that the parking brake is released and the brake force regulator is set in the right position (applies to pneumatic systems with a manual three-position regulator).
- The trailer is adapted for driving on slopes up to a maximum of 8°. Driving with trailer on steeper slopes may cause the trailer to tip over as a result of loss of stability.
- Periodically drain the air reservoir in the pneumatic system. During frosts, freezing water may cause damage to pneumatic system components.
- Reckless driving and high speed can cause an accident.
- Mark a load protruding beyond the outline of the trailer according to the road traffic regulations. It is forbidden to transfer materials not permitted by the Manufacturer.
- Do not exceed the maximum trailer loading capacity. Exceeding of the loading capacity may lead to damage to the machine, loss of stability and cause a hazard while driving. The braking system of the machine has been adjusted to the total weight of the trailer, exceeding which will drastically reduce the operation of the main brake.
- Prolonged driving on slopes creates the risk of losing braking effectiveness.
- When reversing, use the help of another person. While manoeuvring, the helping person must keep a safe distance from the danger zones and be visible to the tractor operator at all times.
- It is forbidden to get on the trailer while driving.
- The trailer must not be parked on a slope.
- If the trailer has a hydraulic suspension, you

may start driving only when it is fully raised. You cannot move the trailer if the suspension is even slightly lowered.

- It is forbidden to drive or disconnect the set (trailer + semi-trailer) from the tractor with the load box raised.

BHP.3.I-004.01.EN

3.7 DESCRIPTION OF RESIDUAL RISK

Pronar Sp. z o. o. in Narew made every effort to eliminate the risk of an accident. However, there is some residual risk that can lead to an accident and is primarily associated with the following activities:

- using the trailer for purposes other than described in the manual,
- being between the tractor and the trailer when the engine is running and when connecting the machine,
- operation of trailer made by unauthorized persons under the influence of alcohol or drugs,
- operation of the trailer by unauthorized persons,
- being on the machine during work,
- trailer cleaning, maintenance and technical inspection.

Residual risk can be reduced to a minimum by following these recommendations:

- prudent and leisurely machine operation,
- reasonable use of the notes contained in the User Manual,
- keeping a safe distance from prohibited and dangerous places,
- a ban on being on the machine while it is operating.
- carrying out maintenance and repair work by trained persons,
- using appropriate protective clothing,
- securing the machine against access by unauthorized persons, especially children.





BHP.3.B-006.01.EN

3.8 INFORMATION AND WARNING STICKERS

- The trailer is marked with the information and warning stickers mentioned in table *Information and warning stickers*.
- The arrangement of symbols is shown in the figure "Arrangement of information and warning stickers". As a user, you are obliged to take care of the legibility of notices, warning and information symbols on the trailer throughout its lifetime.
- In the event of their destruction, they must be replaced. Information and warning stickers can be purchased directly from the Manufacturer or in the place where the machine was purchased.
- Catalogue numbers for stickers can be found in the table *Information and warning stickers* and in the spare parts catalogue. New assemblies replaced during repair must be marked again with the appropriate safety signs. When cleaning of the trailer, do not use solvents that may damage the label coating and do not direct a strong stream of water at them.

Table 3.1. Information and warning stickers

Item	STICKER	Meaning
1		<p>Before beginning of any servicing activities or repairs, turn off the tractor and screen engine and remove the key from the ignition switch.</p> <p>70N-0000005</p>

Item	STICKER	Meaning
2		<p>Regularly check the tightening of road wheel nuts and other bolted connections.</p> <p>104N-00000006</p>
3		<p>Before starting work, read the User's Manual.</p> <p>70N-00000004</p>
4		<p>Danger related to the rotating PTO shaft.</p> <p>78N-00000005</p>
5		<p>The permissible PTO rotation speed is 540 rpm.</p> <p>75N-00000004</p>
6		<p>Trailer type TD218</p> <p>637N-00000001</p>

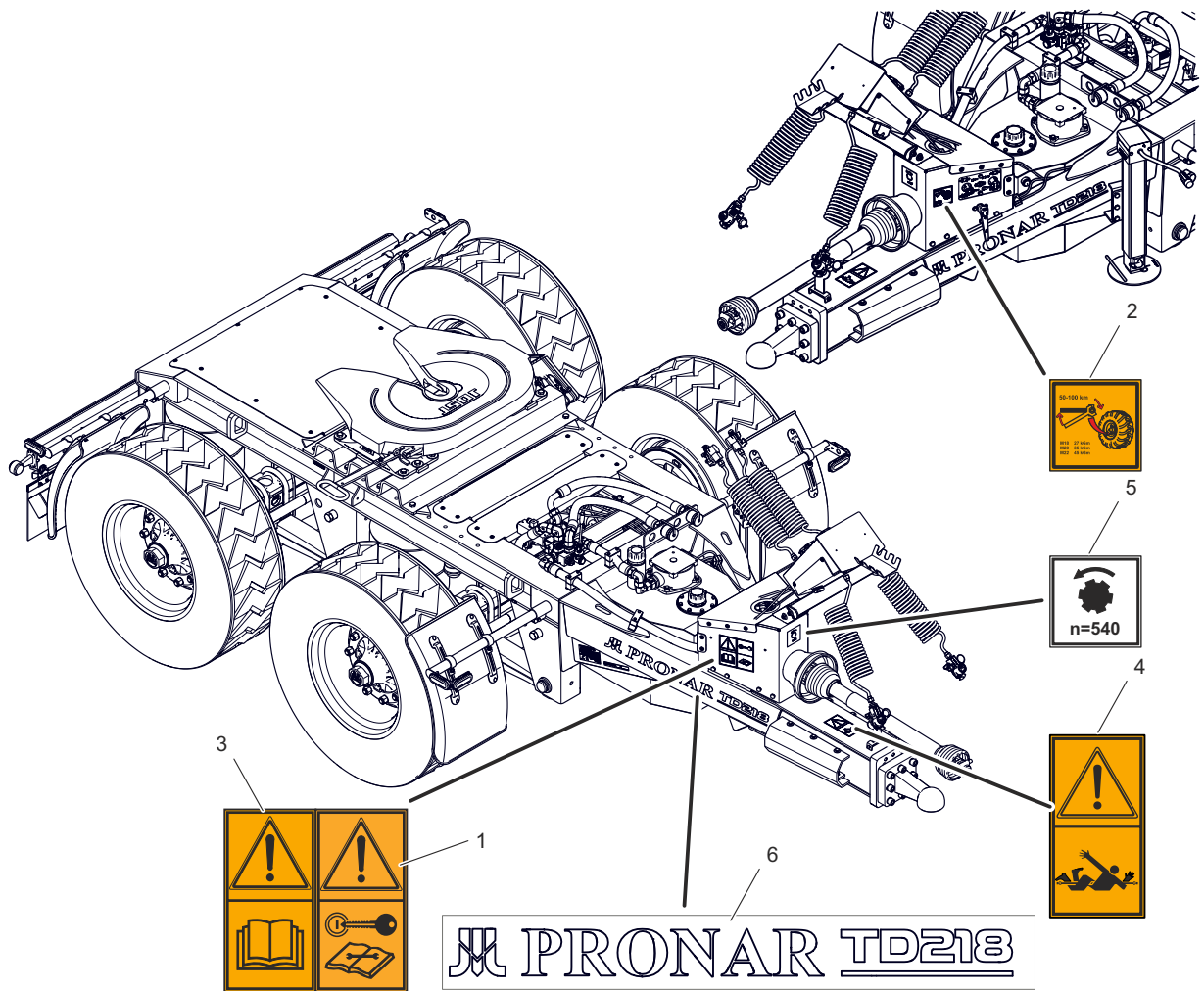

637-F.02-1

Figure 3.2 Arrangement of information and warning stickers

BHP.3.J-001.01.EN

3.9 WORKING WITH THE MACHINE WITH THE POWER TAKE-OFF (PTO)



CAUTION

Before starting work, read the operator's manual of the drive shaft provided by the shaft's manufacturer.

- Before starting work, familiarize yourself with the propeller shaft operating instructions provided by the shaft manufacturer and follow the recommendations contained therein.
- if necessary, adjust the length of the articulated-telescopic shaft to the cooperating tractor in accordance with the shaft's instruction manual.
- The trailer may only be connected to the tractor with the use of a properly selected articulated telescopic shaft, recommended by the Manufacturer.
- The drive shaft must be equipped with covers. It is forbidden to use the shaft with damaged or missing safety elements.
- Some parts of the PTO shaft (especially the clutch) can become very hot. Do not touch hot parts.
- After installing the shaft, make sure that it is correctly and securely connected to the tractor and trailer.
- It is forbidden to wear loose clothing, loose belts or anything that could get caught in the rotating shaft. Contact with rotating PTO shaft may cause serious injury.
- Before disconnecting the shaft, turn off the tractor engine and remove the key from the ignition switch.
- When working in poor visibility, illuminate the articulated telescopic shaft and its surroundings using the tractor's working lights.
- During transport, the shaft should be stored in a horizontal position to avoid damage to guards and other safety devices.
- When using the shaft and trailer, do not use PTO shaft speed other than 540 rpm. Do not overload

the shaft and the machine, do not engage the clutch suddenly. Before starting PTO shaft make sure that the PTO rotation direction is correct.

- It is forbidden to walk over and under the shaft and stand on it both during work and when the trailer is at a standstill.
- The PTO shaft has markings on the housing indicating which end of the shaft should be connected to the tractor.
- Never use a damaged PTO shaft as it may cause an accident. A damaged shaft should be repaired or replaced for new one.
- do not use drive shaft extensions/adapters.
- Disconnect the shaft drive each time when there is no need to drive the machine, or when the tractor and trailer are in an unfavourable angular position with respect to each other.
- Protect chain securing the shaft cover against turning while the shaft is working, attach it to a fixed structural element of the trailer.
- It is forbidden to use safety chains to support the shaft during standstill or transporting the trailer.

BHP.3.B-008.01.EN

3.10 SAFETY WHEN HANDLING THE FIFTH WHEEL

ADVICE

Information on safety, operation, maintenance and inspection of the fifth wheel is described in a separate manual from the manufacturer of this device.

- When working with lifting equipment, fifth wheel couplings, truck tractors and semi-trailers, the relevant safety regulations in force in a given country (e.g. health and safety at work) apply.
- Before using the trailer, carefully read the manual of the trailer. During operation, follow all recommendations.
- Do not connect the semi-trailer to the trailer, if it does not meet the requirements set by the Manufacturer (permissible fifth wheel load, inadequate connections, etc.).
- Before coupling the semi-trailer, make sure that both machines are technically sound.
- The front of the skid plate must not be sharp as this may damage the fifth wheel coupling or the top plate lining.
- Be especially careful when connecting the semi-trailer.
- When hitching a trailer, observe the relevant safety regulations, e.g. health and safety regulations. The trailer should only be connected to firm, flat ground.
- The fifth wheel may only be used by authorized persons.
- Nobody is allowed to stay between the trailer and the semi-trailer when connecting it.
- The skid plate of the trailer must be at the same height and preferably lower - not more than 50 mm lower - than the coupling plate on the fifth wheel coupling. Pressure losses in the air suspension can change the height of the trailer.
- Check the locking mechanism before driving to make sure it is properly locked. Drive the trailer with the locking mechanism locked and secured only, even when driving without a semi-trailer.

- You can only hitch and unhitch the semi-trailer when the semi-trailer is immobilized with the parking brake, with wedges placed under the rear wheels and the parking stands lowered.
- Installation work may only be performed by authorized specialists.
- For maintenance work, use only the recommended lubricants.
- Maintenance and cleaning work should be performed only by trained personnel.

BHP.3.I-006.01.EN

CHAPTER 4

CONSTRUCTION AND PRINCIPLE OF OPERATION

PRONAR TD218

4.1 TECHNICAL CHARACTERISTICS

Table 4.1. Basic technical data

Content	Unit	TD218
Overall dimensions		
Total length	mm	4,630
Total width	mm	2,525
Total height	mm	1,730
Width with semi-trailer (max.)	mm	2,550
Height with semi-trailer (max.)	mm	4,000
Performance parameters		
Karb weight	kg	2,925
Technically (structurally) permissible total weight	kg	21 000 ⁽¹⁾
Permissible total weight (acc. To EU approval)	kg	18,000
Load capacity (according to EU approval)	kg	18 000 ⁽¹⁾
Saddle height (in running order)	mm	1 200 - 1 300 ⁽²⁾
The hydraulic system		
Oil demand	L	150
Pressure of the system	bar	240
Hydraulic oil	-	L-HL32 Lotos
Tires		
Tire	-	385/65 R22.5
Air pressure in the tires	KPa	800
Load index (min.)	-	160
Speed index (min.)	-	E
Noise testing		
Sound power level L_{PA}	dB	73.1 ±5
Other information		
Design speed	km/h	40
Track width	mm	2,050

Content	Unit	TD218
Drawbar eye load		
- Ø40, Ø50	kg	3,000
- K80	kg	4,000
Minimum tractor power requirement	kW/HP	133.8 / 182
Connection of electrical installation	V	12
Suspension	-	pneumatic tandem
(1) - with the fifth wheel positioned as far forward as possible (2) - depending on the air suspension height setting * - depending on the legal restrictions in the country of sale and the completion of the trailer, the above data may differ from those given herein.		

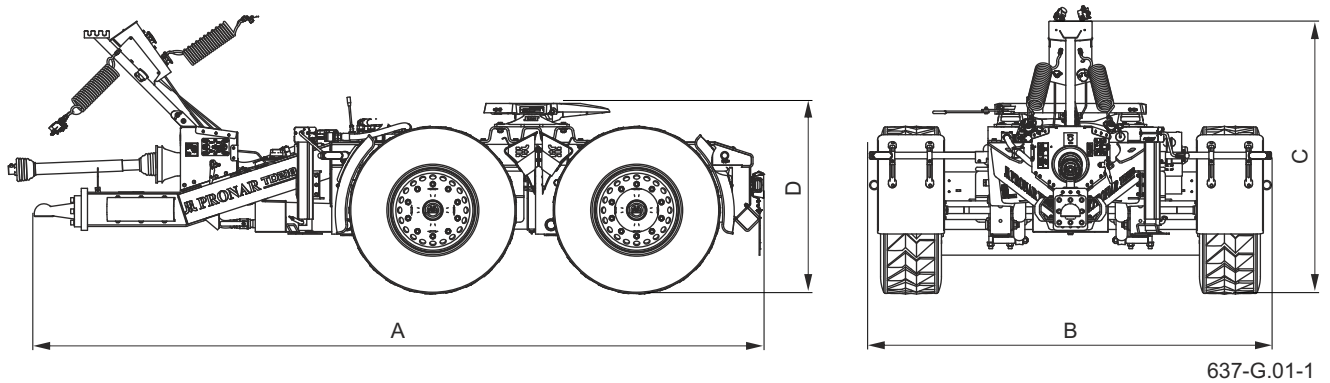

Figure 4.1 Basic dimensions of the trailer

Table 4.2. Main dimensions of the trailer

CAUTION

Depending on the trailer's additional equipment, some technical parameters may change.

Content	Unit	TD218
Total length A	mm	4,630
Total width B	mm	2,525
Overall height C ¹	mm	1,730
Height of the fifth wheel from the ground D ⁽²⁾	mm	1,200 - 1,300
(1) - depending on the completion of the trailer tires, the above data may differ from those given. (2) - depending on the air suspension height setting		

4.2 CONSTRUCTION OF A TRAILER

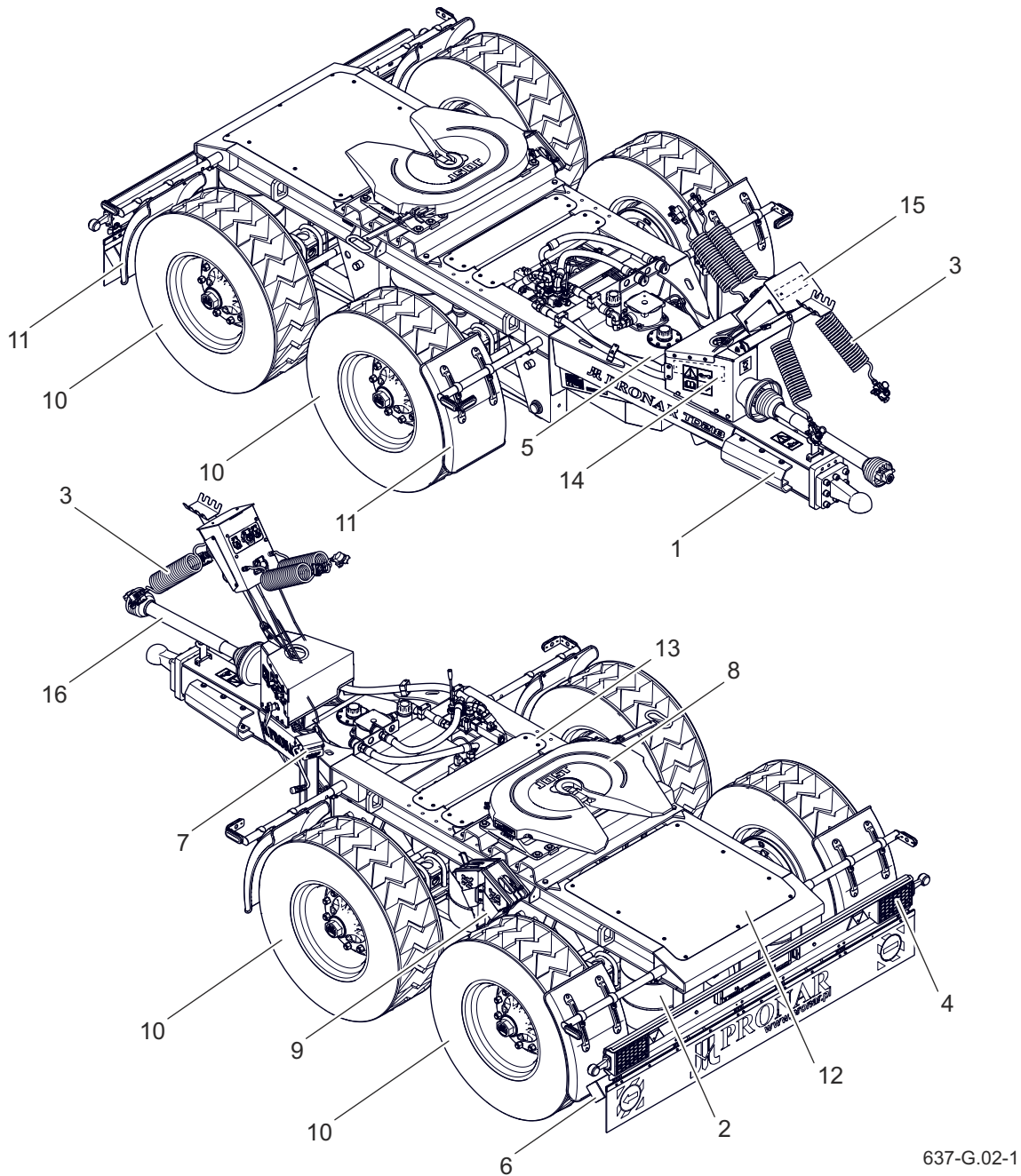

Figure 4.2 General structure of the trailer
(1) frame (2) air suspension (3) air system
(4) rear lighting (5) hydraulic system (6) rear protection
(7) parking stand (8) fifth wheel coupling (9) wheel chock
(10) wheel (11) fender (12) rear masking
(13) front grille (14) voltage converter 12V / 24V (15) ABS voltage converter
(16) parking stand

637-G.02-1

The trailer is equipped with, among others: air suspension (2) that allows it to be raised and lowered, two-circuit air braking system (3) with a levelling valve and an automatic parking brake. An independent hydraulic system (4) with a hydraulic pump driven by a PTO (16) was used to tip the trailer. The fifth wheel coupling (8) is mounted on the trailer. The pressure on the drawbar of the trailer is regulated by the position of the fifth wheel. A mechanical parking stand (7) helps to connect the trailer to the tractor.

To power the trailer, the 12V voltage can be converted into 24V using a converter (14). The trailer is also equipped with a converter (15) to power the ABS system of the trailer.

BIZ.3.I-002.11.EN

4.3 PNEUMATIC INSTALLATION

4.3.1 Brake pneumatic system

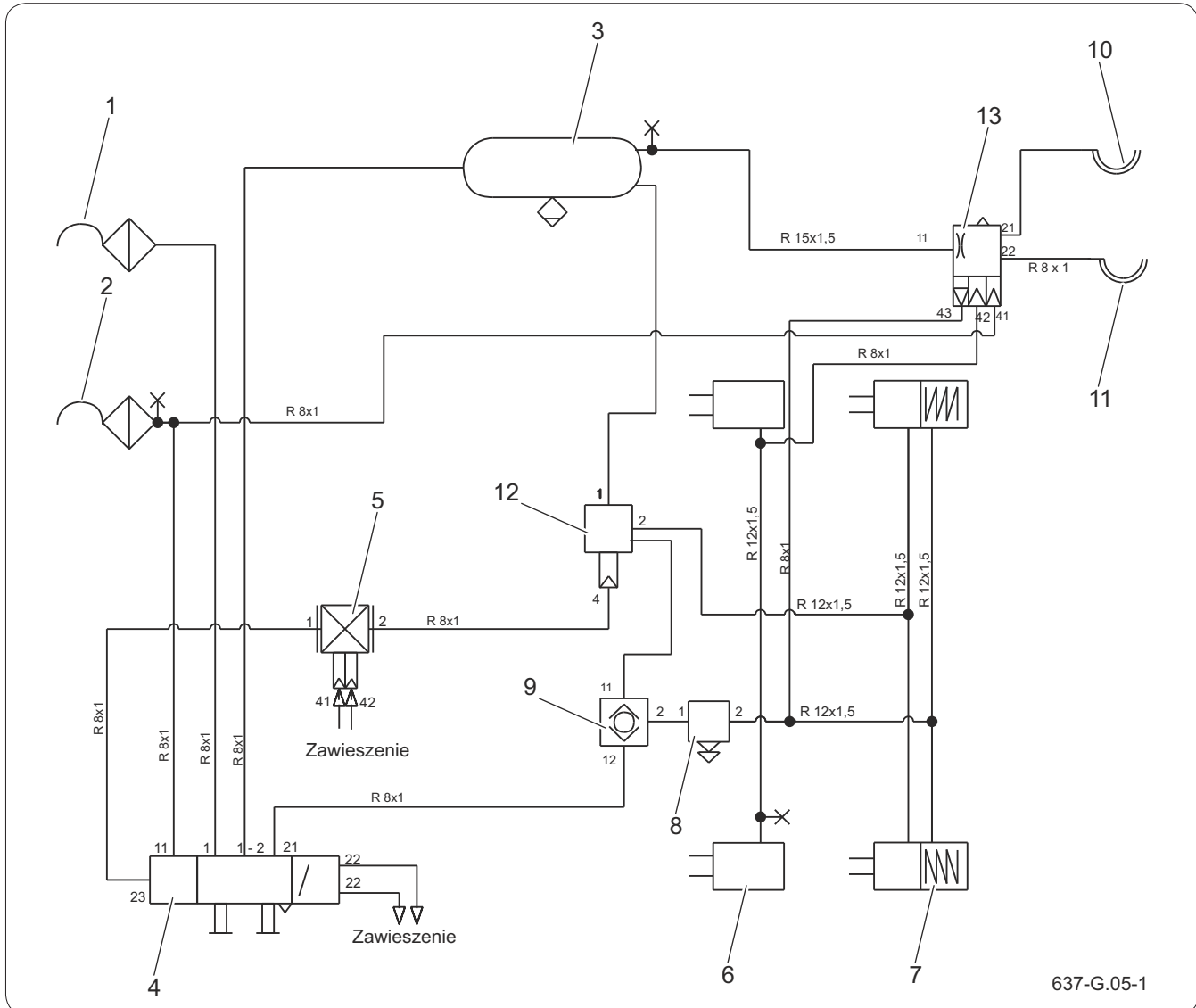

Figure 4.3 Diagram of the pneumatic braking system
 (1) power connector (red) (2) control connector (yellow) (3) air tank
 (4) loosening and parking valve (5) automatic braking force regulator
 (6) diaphragm brake cylinder (7) spring diaphragm cylinder
 (8) quick exhaust valve (9) 3/2-way valve
 (10) trailer power connector (red) (11) trailer control connector (yellow)
 (12) relay valve with a filter (13) trailer brake control valve

The trailer is equipped with a double-line pneumatic ALB braking system with a levelling valve and an automatic parking brake. The working brake is activated from the tractor operator's workplace by pressing the tractor brake pedal. The control valve actuates

the trailer's brakes simultaneously with the tractor's brake.

The automatic braking force regulator adjusts the braking force depending on the current degree of loading and during normal operation it does not require the operator of the trailer.

4.3.2 Pneumatic suspension

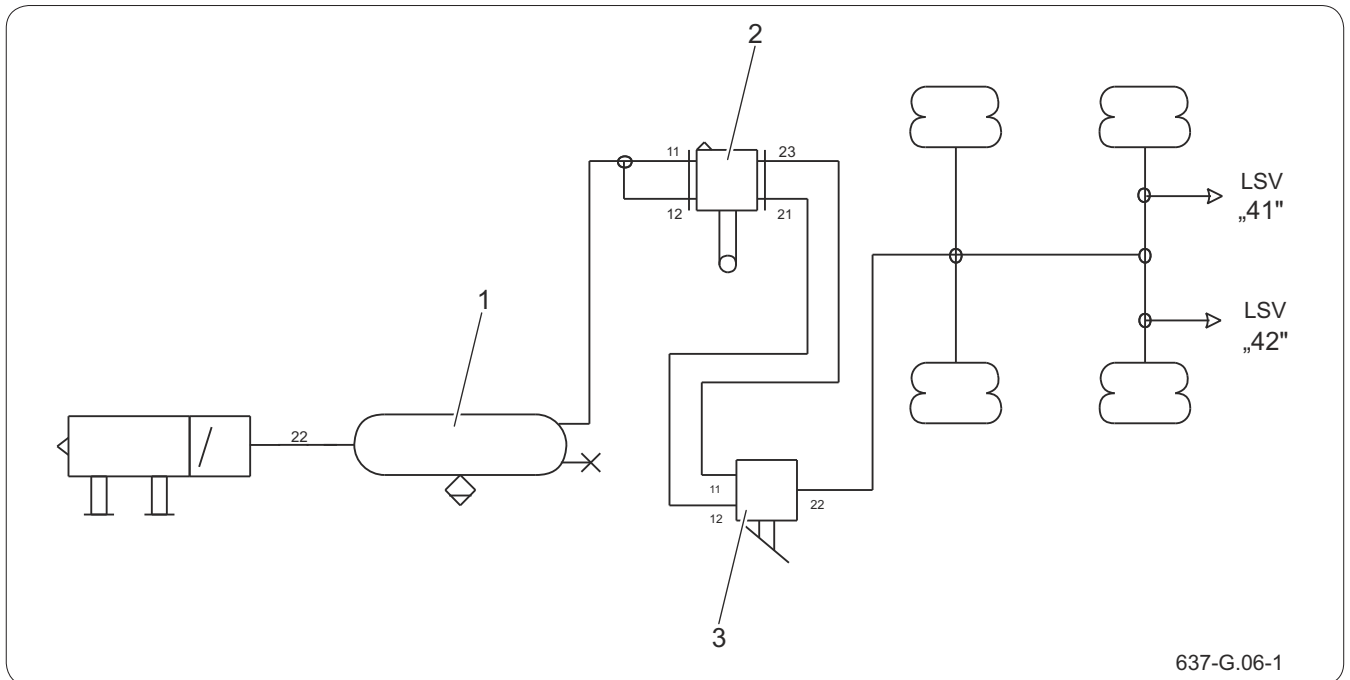

Figure 4.4 Diagram of the pneumatic suspension system
 (1) air reservoir (2) levelling valve with height restriction
 (3) lift/lower valve

4.3.3 Loosening-parking valve

The applied loosening-parking valve is equipped with an emergency brake function, which is activated in the event of a pressure drop in the supply line (cable disconnection, cable damage). Two buttons located on the valve allow you to set the machine to the appropriate operating mode. The red button is responsible for releasing and activating the parking brake in the trailer, regardless of whether the trailer is connected to the towing vehicle or not. The black button is responsible for releasing and activating the

maneuvering brake in a free-standing trailer not connected to a towing vehicle. Information on setting the loosening-parking valve operating mode is presented in the table: *Loosening-parking valve operating modes*.

4.3.4 Pneumatic connections

Pneumatic connections are equipped with covers to protect them against dirt and contamination from entering the system. They are made of coloured plastic (red connector - supply air, yellow connector - control air). Connectors are made in accordance with the recommendations of DIN ISO 1728, thanks to which it is impossible to accidentally connect the connectors to the tractor sockets. Pneumatic connections are integrated with air filters, which protect the pneumatic installation against the ingress of dirt. After unhitching the trailer, pneumatic connections should be placed in specially prepared sockets.

4.3.5 ABS function

The trailer is equipped with a converter to power the ABS system of the car trailer. The task of the ABS system is to prevent the wheels from locking during braking. The operation of this system can be compared to pulsed braking. Rotational speed sensors read the values of changes in the rotational speed of the wheels. If any wheel locks during braking or its speed changes significantly in relation to the other wheels, information is transmitted to the control system, which in turn reduces the air pressure in the cylinder braking the wheel. Locking the wheels while braking is a very dangerous phenomenon. The ABS function significantly reduces the loss of stability of the semi-trailer and reduces the braking distance of the machine.

4.4 THE HYDRAULIC SYSTEM

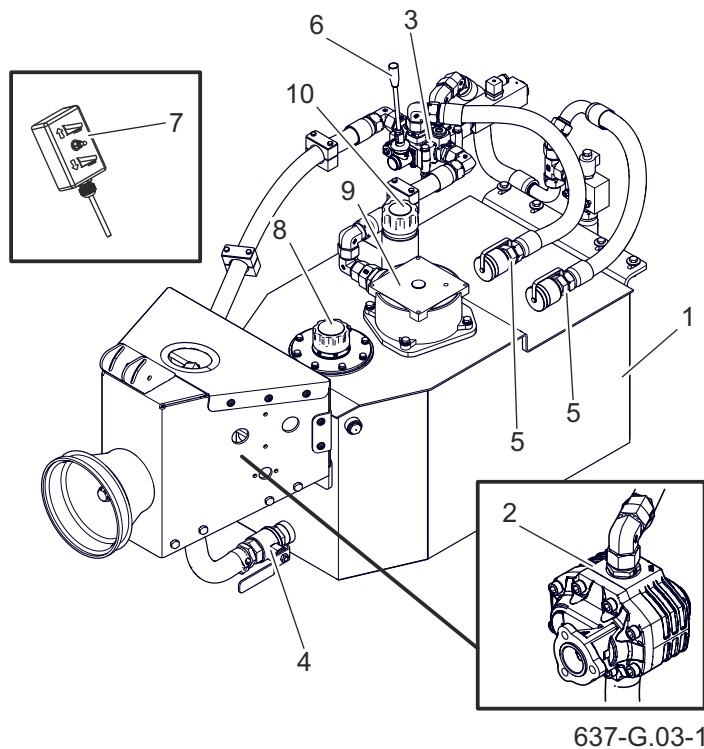

Figure 4.5 Construction of a hydraulic system with an oil tank
 (1) oil tank (2) gear pump (3) distributor
 (4) cut-off valve (5) quick coupler socket (6) manifold lever
 (7) pilot (8) filler plug with filter (9) oil filter
 (10) breather

ADVICE

The hydraulic system is filled with L-HL32 PN-91 / L-96067/04 hydraulic oil.

The trailer uses an independent hydraulic system for tipping the semi-trailer, driven by the agricultural tractor's PTO shaft. The lever (6) of the hydraulic distributor (3) or the remote control (7) is used to control the tipping of the semi-trailer.

BIZ.3.I-003.11.EN

4.5 ELECTRICAL SYSTEM

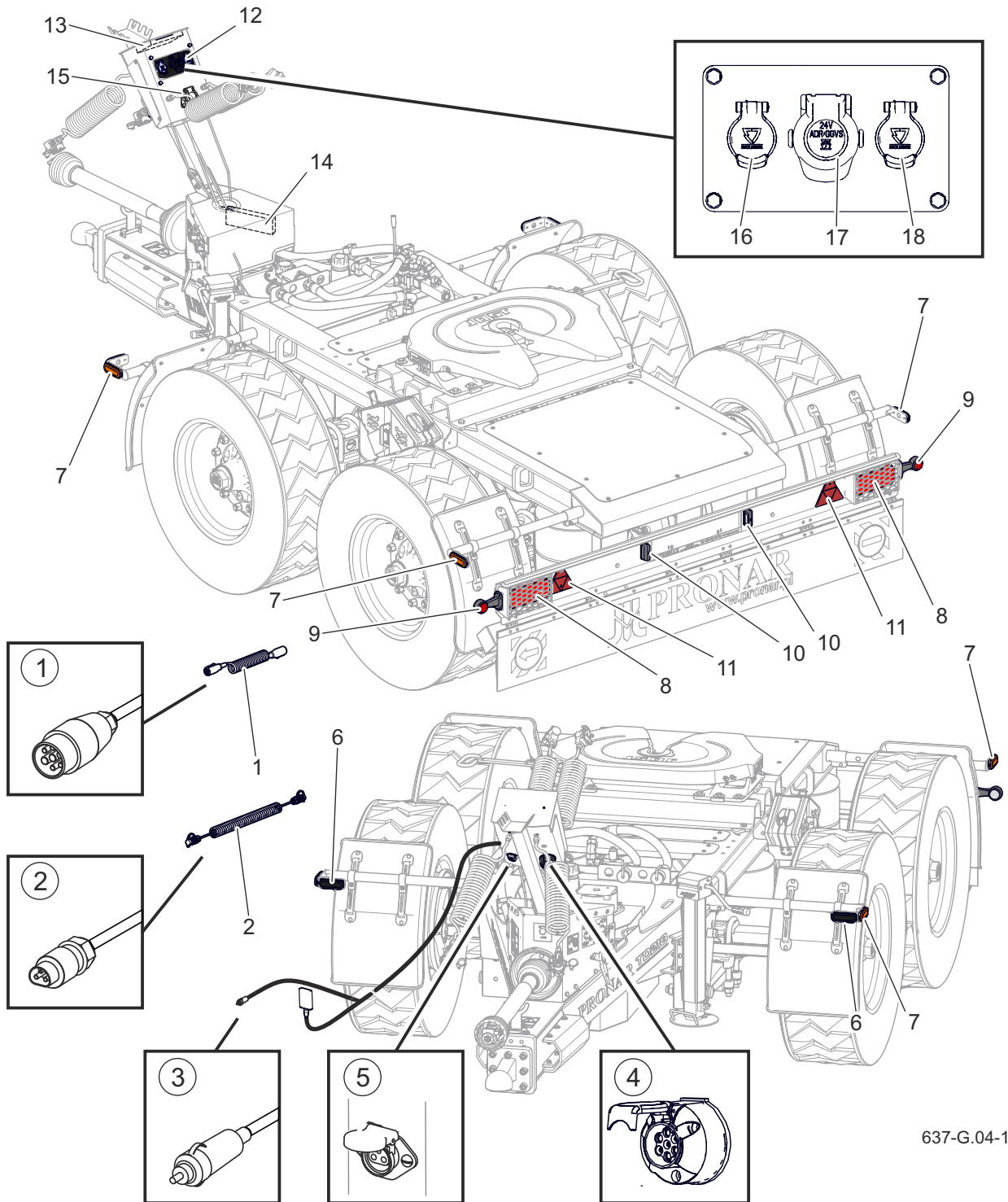

637-G.04-1

Figure 4.6 Arrangement of electrical system components and reflective elements

- (1) 7-pin connection cable (2) 3-pin connection cable (3) cigarette lighter plug
 (4) 7P/12V socket (5) 3-pin socket (6) front position lamp
 (7) side position lamp (8) rear combination lamp (9) rear clearance lamp
 (10) license plate lamp (11) rear triangle reflector (12) junction box
 (13) ABS voltage converter (14) 12/24 voltage converter (15) 7P/24V ABS socket
 (16) 7P/24V socket (ISO 3731) (17) 15P / 24V socket (ISO 72570)
 (18) 7P/24V socket (ISO 1185)

**CAUTION**

Before driving, check the operation and completeness of the electrical system.

Driving with faulty lighting installation is forbidden.

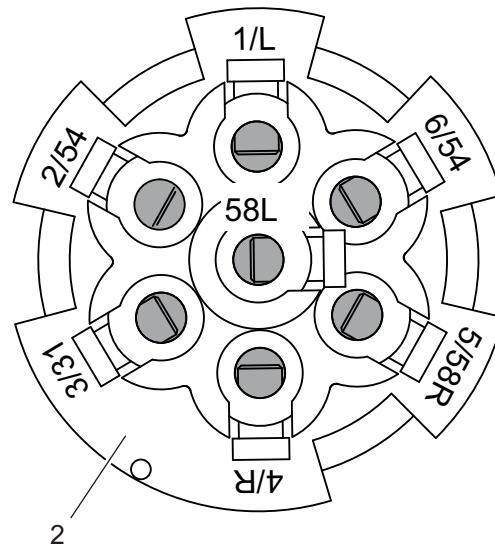
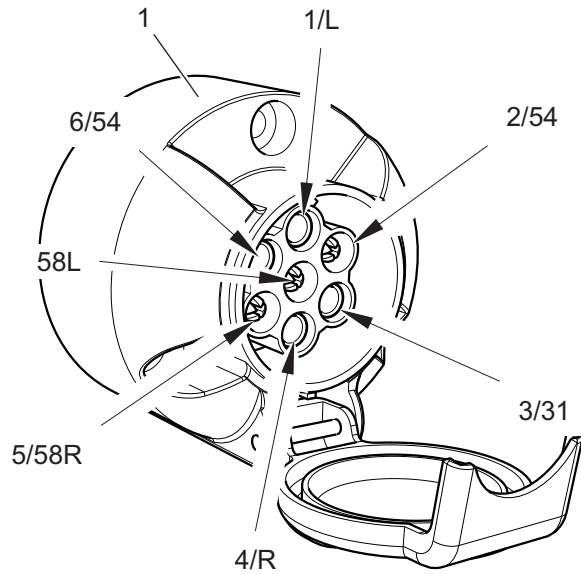

657-G.11.1

Figure 4.7 7P/12V socket
(1) socket (2) view from the beam side

The electrical installation of the trailer is adapted to be supplied from a DC source with a voltage of 12V. Connect the electrical system of the machine with the tractor with the help of connection cables (1) (2) attached to the trailer.

The trailer is powered by a junction box (12), and the 12V voltage can be converted into 24V using a converter (14). The trailer is also equipped with a converter (13) to power the ABS system of the trailer.

The electrical system for controlling the hydraulic

Table 4.3. Connection markings for the connection socket

Marking	Function (wire colour)
1/L	Left indicator (yellow)
2/54	Not used
3/31	Ground (white)
4/R	Left indicator (yellow)
5/58R	Rear right position light (brown)
6/54	STOP light (red)
58L	Left rear position lamp (black)

solenoid valves is powered by the cigarette lighter socket

If the tractor does not have such sockets or the sockets are of a different type then assembly should be carried out by a qualified person in accordance with the recommendations of the tractor manufacturer.

BIZ.3.I-004.11.EN

CHAPTER 5

RULES OF USE

PRONAR TD218

5.1 MECHANICAL SUPPORT



DANGER

Be careful as there is a risk of crushing your feet.

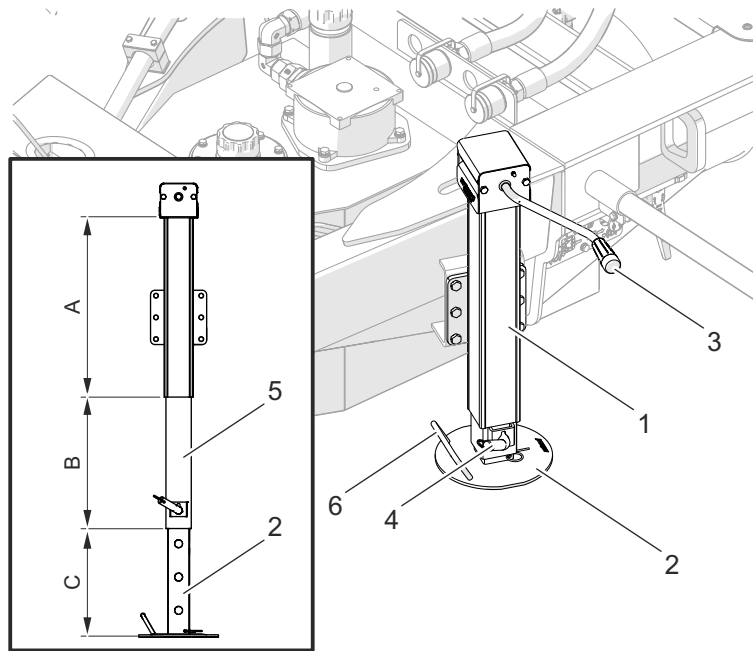

663-H.01-1

Figure 5.1 Mechanical support

- (1) support (2) support foot
 (3) crank (4) securing pin
 (5) central tube (6) foot holder
 (A) main tube length - 500mm
 (B) stroke - 290mm
 (C) stroke - phase 2 - 276mm

Determining of the correct height of the drawbar eye in relation to the tractor hitch is achieved with the help of a mechanical parking stand.

Lifting up of the support

- Turn the crank (3) in the appropriate direction to raise the centre tube (5) as far as it will go.
- Holding the handle of the foot (6), remove the locking pin (4).
- Using the handle (6), raise the support foot (2) as far as possible.
- Install the locking pin.

Lowering the support

- Holding the handle of the foot (6), remove the locking pin (4).
- Lower the support foot (2) and secure with the pin (4).

- By turning the crank (3) in the right direction, lower the support to the ground, or adjust the height of the tendon in relation to the hitch (if the trailer is to be connected to the tractor).

OBS.3.I-001.01.EN

5.2 SERVICE OF THE FOLDING HYDRAULIC SUPPORT



DANGER

Take special care when operating the support - it also applies to bystanders or assistants.

Be especially careful when rotating the support. Do not put your hands between the support mounting socket and the support. Danger of cutting or crushing.

Placing the support in driving position

- Immobilize the tractor and trailer with parking brake.

The machine must be connected to the tractor. Connect the hydraulic hose (6) to the hydraulic socket on the tractor.

- Open the valve (5) by moving the handle along the valve body to the open position.
- By operating the distributor in the tractor, raise the support foot.
- Lock the support position by moving the handle perpendicular to the valve body (5) in the closed position.
- Release the cotter pin (4) and remove the locking pin (3) from the hole in position (A).
- Turn the support foot to position (2).

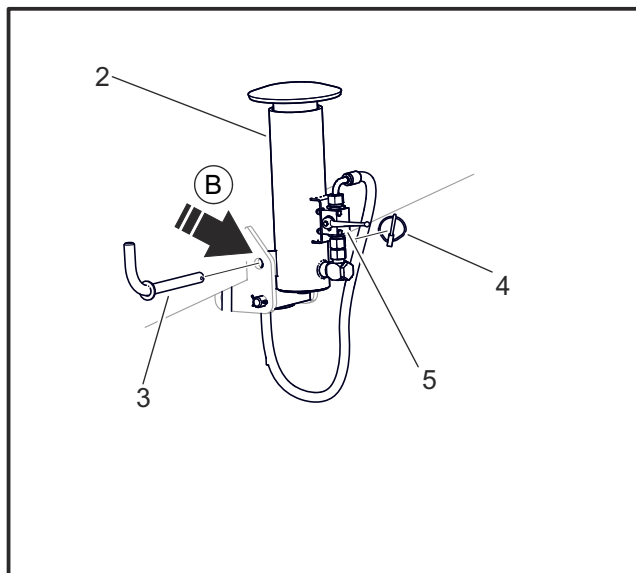
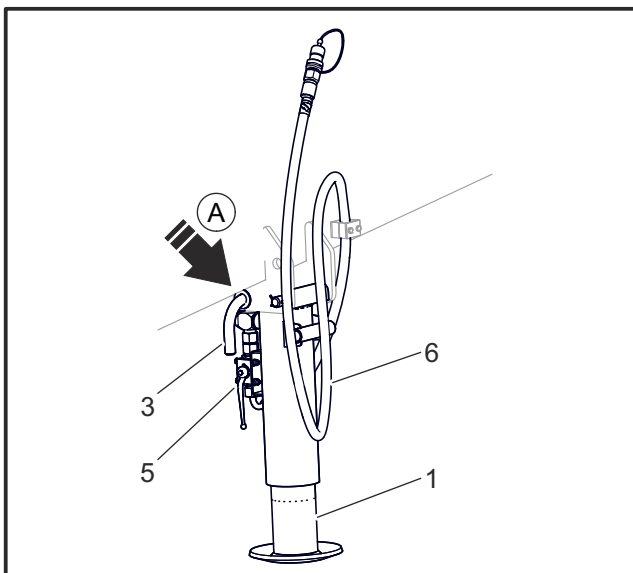

663-H.02-1

Figure 5.2 Handling of the hydraulic support
 (1) support in parking position (2) support in driving position (3) securing pin
 (4) split pin (5) cut-off valve (6) hydraulic conduit
 (A), (B) position of locking pin

**CAUTION**

You cannot move the set (tractor and trailer) with the support raised only with the use of the cylinder. The support must be moved to the driving position.

It is forbidden to pass the set if the elements of the support protection - pin (3) and cotter pin (4) are damaged or lost.

- Place it with the cotter pin (4).
- Release the parking brake of the trailer before driving.

Positioning of the support to parking position

- Immobilize the tractor and trailer with parking brake.
- Release the cotter pin (4) and pull the safety pin out from (B) position.
- Turn support to position (1).
- Move the pin to position (A) and secure with a cotter pin (4).
- Set the shut-off valve (5) to the open position.
- By operating the distributor in the tractor, lower the the support foot.
- Drawbar eye should be slightly raised in relation to the hitch in the tractor, which will facilitate the subsequent connection of the trailer.
- When the height of the drawbar eye is set, set the tractor manifold lever in the "neutral" position.
- Lock the support position by moving the valve lever (5) to the closed position.

OBS.3.8-002.11.EN

5.3 CONNECTING AND DISCONNECTING OF THE TRAILER

5.3.1 Connecting of the trailer



CAUTION

After connecting the trailer, perform a daily inspection of the machine before driving.

The external examination of the machine without connecting it to the tractor will not allow verification of its technical condition.

The trailer may be connected to an agricultural tractor if all connections (electrical, pneumatic, hydraulic) in the agricultural tractor are in accordance with the trailer manufacturer's requirements specified in the table Requirements of the agricultural tractor.

Preparation

- Make sure that the trailer is immobilized with the pneumatic parking brake - see the table "Loosening-parking valve operation modes".

If there is a mechanical hand brake, turn the brake mechanism clockwise until it stops.

- Make sure that blocking chocks are placed under the trailer wheel - figure (5.5).
- Position the agricultural tractor directly in front of the drawbar eye.

Drawbar height adjusting

- If the trailer is equipped with a hydraulic support, first connect the hydraulic conduit of the system

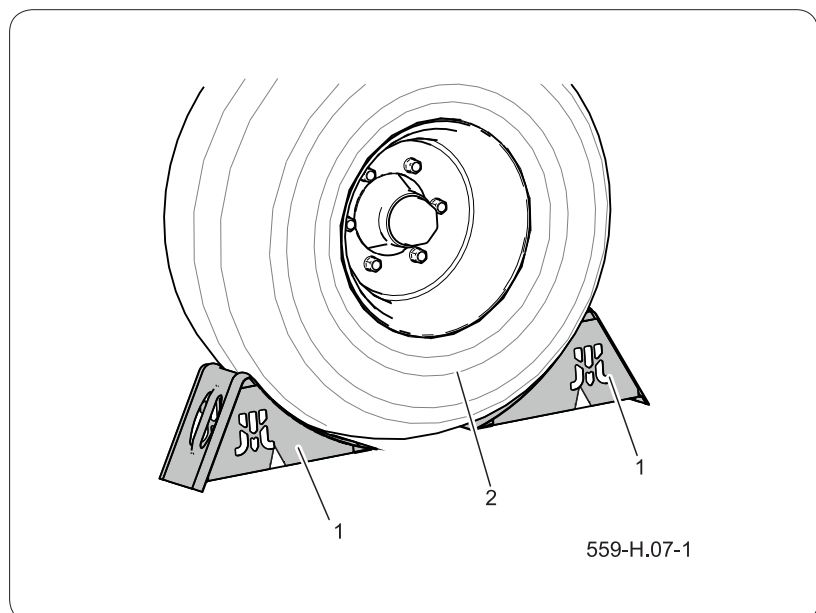

Figure 5.3 Locking wedges
(1) locking wedges (2) wheel

marked with a decal (1) - figure (5.4). Then follow

**DANGER**

During hitching, there must be no bystanders between the trailer and the tractor. The agricultural tractor operator when connecting the machine should take particular care and be sure that unauthorized persons are not in the danger zone during coupling.

Be especially careful when coupling the trailer.

Ensure good visibility during coupling.

After completing the coupling check the safety of the pin hitch.

the chapter on *Hydraulic support*.

If the trailer is equipped with a parking stand with mechanical transmission, the adjustment is made with the support gear - see "Mechanical support".

Connecting the trailer to the tractor hitch

- Reverse the tractor and connect the trailer to the appropriate hitch.
- Check the coupling lock protecting the machine

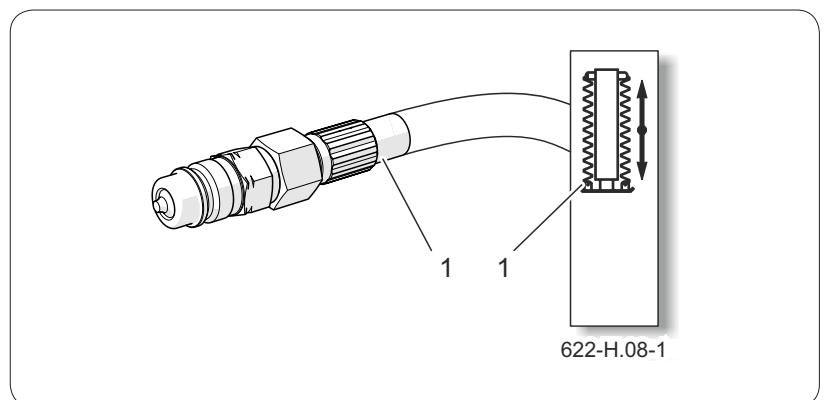

Figure 5.4 Hydraulic support connection
(1) Information sticker

against accidental disconnection.

- If an automatic coupling is used in the tractor, make sure that the aggregation operation is completed and the drawbar eye is secured.
- Set the parking stand to the transport position.
- Turn off the tractor engine and remove the ignition key. Secure tractor with parking brake. Close the tractor cabin and secure it against unauthorized access.

Connecting of the braking system

- Depending on the trailer configuration, connect the braking system connectors to the appropriate tractor sockets.
- Connect the pneumatic system lines.

The first is to connect the yellow plug to the yellow socket on the tractor, and then to the



CAUTION

When connecting pneumatic conduits of a two-conduit system, connect the yellow conduit first, and then the red conduit.

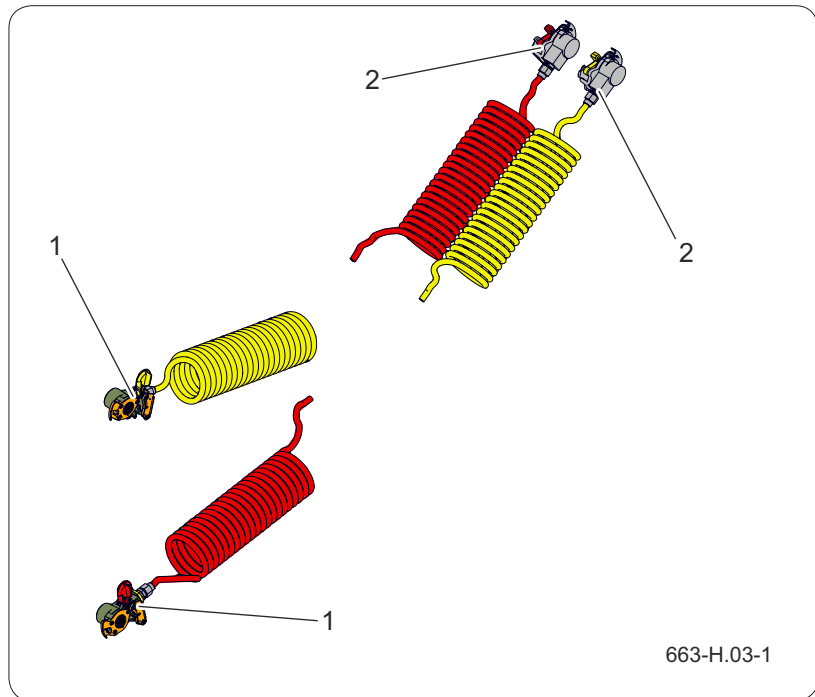

Figure 5.5 Connections of the braking system
 (1) pneumatic plug (red, yellow) - to the tractor
 (2) pneumatic plug (red, yellow) - to the semi-trailer

red plug to the red socket on the tractor. After connecting the second conduit, the brake release system will revert to normal operating mode (disconnecting or breaking the air conduit causes the trailer control valve to automatically set itself to the machine brake actuating position).

- If the brakes do not respond after connecting the pneumatic conduits, it may be a sign of low pressure in the tank. In order for the system to start work, it must be filled with the appropriate pressure.

Connecting of the electrical installation

- Connect the main conduit (1) supplying the electrical lighting system (7-pin) and the connection conduit (2) of the electrical system of the hydraulic system (3-pin) to the sockets on the tractor.

If the tractor does not have such sockets or

**CAUTION**

After completing the coupling, secure the hydraulic, braking and electrical wiring in such way, that they do not become entangled in the moving parts of the agricultural tractor during travel and are not exposed to kinking or cutting during turning.

**CAUTION**

When the trailer is parked for a longer period, it may turn out that the air pressure in the air braking system is insufficient to release the brake shoes. In this case, wait until the air in the pneumatic system tank is replenished after starting the tractor and the air compressor.

**DANGER**

It is forbidden to use an inefficient trailer.

the sockets are of a different type then assembly should be carried out by a qualified person in accordance with the recommen-

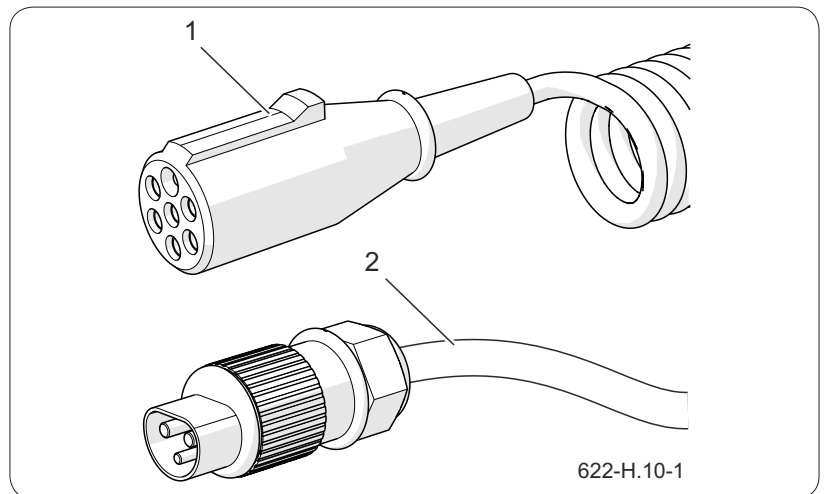

Figure 5.6 Connection of electrical installation
(1) 7-pin cable (2) 3-pin cable

dations of the tractor manufacturer.

- Plug the remote control power harness into the cigarette lighter socket. Place the remote control in the operator's cabin in an accessible place.

Additional information

- After completing the connection of cables make sure that they will not get entangled in moving parts of the tractor or trailer during operation. Secure cables if necessary.
- Connect the PTO shaft to the tractor PTO shaft and secure it with the chains.

If shaft shortening is required, it should be done in accordance with the shaft manufacturer's manual attached to the shaft.

- Perform daily inspection of the trailer.
- If the trailer is in good state, you can start working.
- Immediately before driving, remove the chocks from the wheel and release the parking brake of the machine - see the table "Operation modes of the loosening-parking valve".

In the event of a mechanical handbrake, turn the crank of the brake mechanism counter-clockwise as far as it will go.

5.3.2 Disconnecting the trailer



DANGER

When disconnecting the trailer from the tractor, take particular care.

Ensure good visibility. Unless it is necessary, do not stay between the trailer and the tractor.

Before disconnecting wires and drawbar close tractor cab and secure it against unauthorized access. Turn off the tractor engine.



CAUTION

When disconnecting pneumatic conduits of a double conduit system, disconnect the conduit marked red first, and only then the conduit marked yellow.

- Place the trailer on a hard and flat surface.
- The tractor and trailer must be in a straight line. The tractor must not be turned in relation to the trailer axis because it will make it very difficult to aggregate the trailer.
- Lower the support to parking position.
- Turn off the tractor engine and remove the ignition key.
- Secure the tractor with the parking brake.
- Block the trailer with the mechanical parking brake (if present).
- Place blocking wedges under one wheel of the trailer, one in the rear and the other in front of the wheel.
- Disconnect all cables in turn. The parking valve of the trailer braking system automatically switches to the "braked" position. Secure the ends of the hydraulic hoses by fitting the rubber caps on the hydraulic connectors.
- Place the hoses on the wire bracket.
- Release the drawbar eye, start the tractor and drive away with the tractor.

5.3.3 Parking brake

The trailer is equipped with a pneumatic brake system. Spring-diaphragm actuators used in the service and parking brake systems generate the braking force. To activate the parking brake, pull out the red button located on the loosening-parking valve panel. To release the parking brake, press the red button.

Loosening-parking valve

The valve is used in towed vehicles where a pneumatic brake system and spring diaphragm actuators are used.

In the event of deliberate or accidental disconnection of the pneumatic supply, the valve activates an emergency brake function.

The red button is responsible for releasing and activating the parking brake in the trailer, regardless of whether the trailer is connected to the towing vehicle or not.

The black button is responsible for releasing and activating the maneuvering brake in a free-standing trailer not connected to a towing vehicle.

Remember to pull out the black button when disconnecting the power from the trailer.

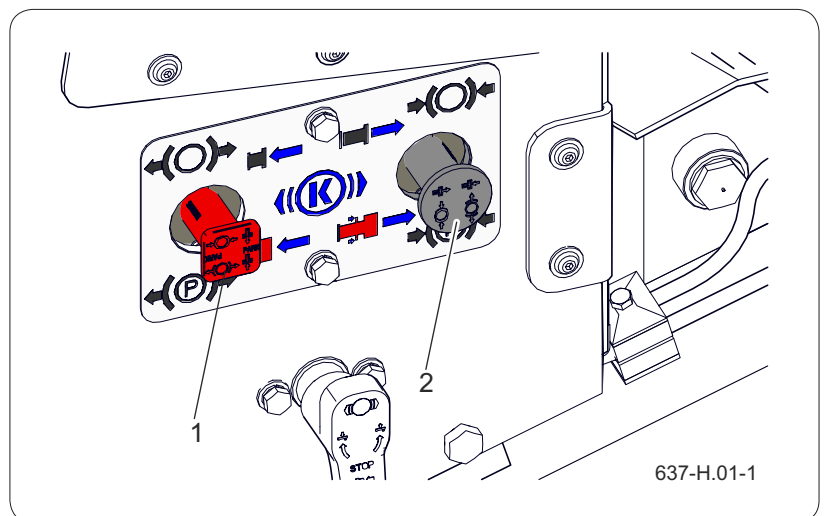
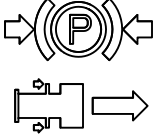
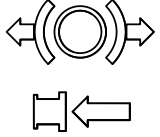
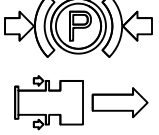
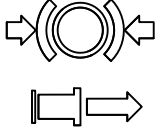
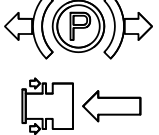
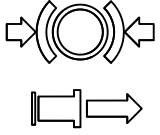
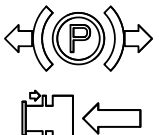
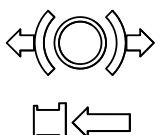

Figure 5.7 Loosening-parking valve
(1) red button (2) black button

Table 5.1. Modes of operation of the loosening-parking valve

Option	Button Red	Button Black	Description
A	NOT PRESSED 	PRESSED 	The machine is braked with the parking brake. When the red button is pulled out, the trailer is immobilized with the parking brake, regardless of the position of the black button.
B	NOT PRESSED 	NOT PRESSED 	
C	PRESSED 	NOT PRESSED 	<p>The machine is ready to drive. Pneumatic hoses connected to the trailer. It is not possible to press the black button.</p> <p>The machine is braked. Pneumatic hoses are not connected. Pressing the black button will release the brake.</p>
D	PRESSED 	PRESSED 	<p>Parking brake released, maneuvering position</p> <p>The trailer is completely unbraked. Pneumatic hoses are not connected.</p>

OBS.3.I-002.11.EN

5.4 FIFTH WHEEL HANDLING



DANGER

When hitching a trailer, observe the relevant safety regulations, e.g. health and safety regulations. The trailer should only be connected to firm, flat ground.



CAUTION

Modifications of any kind will void the warranty.

ADVICE

Information on safety, operation, maintenance and inspection of the fifth wheel is described in a separate manual from the manufacturer of this device.

JOST fifth wheels are mechanical coupling devices and form the link between the trailer and the semi-trailer.

Fifth wheel couplings are manufactured in accordance with Directive 94/20 EC in 50 class and may only be used in conjunction with class H50 journals, steering wedges and mounting plates of J class or with other equivalent approved devices.

The data on the maximum load of JOST fifth wheel couplings can be found on the nameplate or on the relevant pages of the "Assembly and operating instructions" of JOST. These apply to the intended use in accordance with regulation ECE R55-01.

Opening the fifth wheel coupling

- Lift up the safety catch (1).
- Move the lever (2) forward to A position (release of the lock), and then pull it out until it reaches the end position in B position.
- Pull the lever (2) out to the front to position C and hook it to the edge of the D plate.

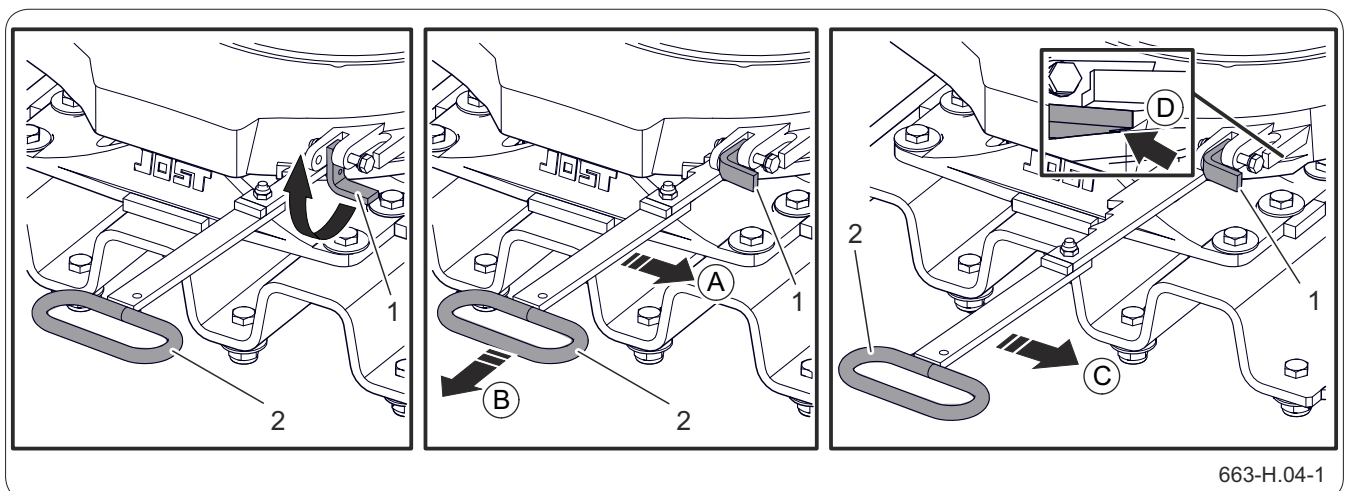

663-H.04-1

Figure 5.8 Opening of the fifth wheel coupling
(1) safety catch (2) lever

Requirements for the trailer skid plate

The skid plate on a semi-trailer that engages with the fifth wheel coupling must meet the following conditions to ensure a long service life and trouble-free operation:

- unevenness max 2 mm,
- as smooth and free of grooves as possible, without welding bulges (the burrs should be ground off),
- rounded or bevelled front and side edges,
- complete covering of the fifth wheel support surface.

Sliding fifth wheel coupling

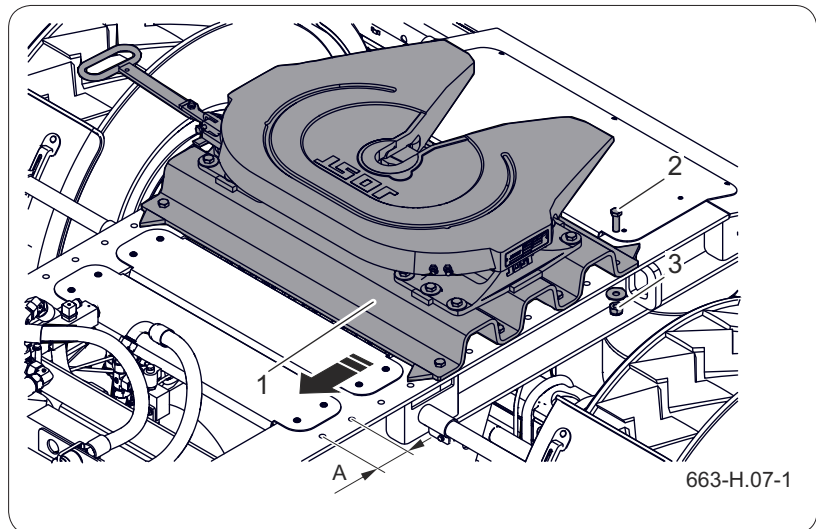

Figure 5.9 Longitudinal adjustment of the saddle
(1) seat plate (2) bolt (3) nut
(A) longitudinal travel - ~ 104mm

The pressure on the drawbar of the trailer is regulated by the position of the fifth wheel. Changing its position in the longitudinal direction enables:

- coupling of the trailer with most of the used semi-trailers,
- adaptation to the regulations on axle loads and vehicle lengths in force in different countries,
- optimal load distribution.

**DANGER**

Nobody is allowed to stay between the trailer and the semi-trailer when connecting it. Before driving, check the condition of the locking mechanism and that the engagement is correct. Check the lubrication of the pin, coupling and ramp plate of the semi-trailer.

**CAUTION**

The slide plate must rest without a gap on the fifth wheel coupling.

**CAUTION**

Before driving, check the operation of the lighting and brakes.

Coupling with a trailer

- Immobilize the trailer by applying the parking brake and placing chocks under the rear wheels.
- Unlock the coupling on the trailer's fifth wheel.
- Check the height of the semi-trailer and use the supporting legs to adjust the height of the semi-trailer ramp.

When coupling, the skid plate of the semi-trailer should be at the same height and preferably lower (maximum 50 mm) than the fifth wheel coupling plate of the trailer.

The height of the trailer hitch can be adjusted using the lifting and lowering valve (1) of the trailer air suspension.

- Reverse the set (tractor with trailer) until the coupling clicks on the trailer pin.

The locking mechanism will close automatically.

- Check the coupling (move the tractor slowly), repeat the coupling if necessary.
- Activate the tractor parking brake.
- Check the locking mechanism.

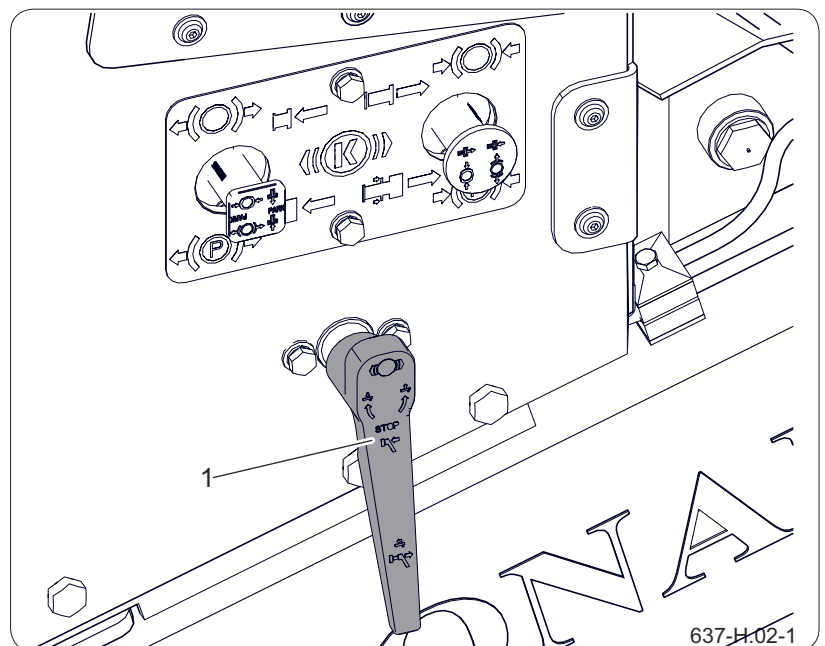

Figure 5.10 Lifting/lowering valve



CAUTION

Check how the load is distributed on the trailer. A heavy load at the rear or front of the trailer may cause the trailer to tip over.

The safety catch (1) must be in the lower position - Figure 5.7.

To secure the fifth wheel coupling against unauthorized opening, a securing device (e.g. a padlock) can be inserted into the opening of the lever.

- Connect the power cords.
- Raise the support legs of the trailer.
- Check the operation of the lighting.
- Release the parking brakes and remove the wheel chocks.
- Check the operation of the service brakes.

Uncoupling of the set

- Park the set on flat, hard ground.
- Immobilize the trailer by engaging the parking brake and placing chocks under the rear wheels.
- Extend the supporting legs of the semi-trailer to relieve the fifth wheel coupling.
- Disconnect the power cords.

Disconnect the pneumatic hoses in the following order: red first, then yellow.

- Open the locking mechanism.

See: “Opening of the fifth wheel coupling”.

- Drive the tractor slowly away from under the trailer.
- The fifth wheel is automatically ready to be inserted again.

OBS.3.I-003.11.EN

5.5 TRANSPORT

When driving on public roads, comply with the road traffic regulations and transport regulations in force in the country in which the trailer is used. Remember about the prudence and reasonable behaviour. The most important tips for driving a tractor with a connected set (trailer + semi-trailer) are presented below.

- Before moving make sure that there are no bystanders, especially children, near the trailer and semi-trailer. Ensure proper visibility.
- Make sure that the trailer is correctly connected to the tractor and tractor's hitch is properly secured.
- Before driving, check the condition of the trailer's locking mechanism and that the coupling with the semi-trailer is correct.
- It is forbidden to drive or disconnect the trailer from the tractor with the load box raised.
- Vertical load carried by the trailer drawbar eye affects the steering of the agricultural tractor.
- Do not overload the trailer. The load must be evenly distributed so that the maximum permissible axle loads are not exceeded. Exceeding the permissible load capacity of the vehicle is prohibited and may damage the machine. Overloading is a road travel hazard for the tractor and trailer operator or other road users.
- The permissible design speed and speed resulting from restrictions on road traffic regulations must not be exceeded. The travel speed should be adjusted to the prevailing road conditions, trailer load condition, type of load carried and other conditions.
- If you disconnect the trailer from the tractor, you must secure it by blocking it with the parking brake and placing wedges under the wheels.



CAUTION

It is prohibited to leave the trailer unsecured.

In the event of a machine breakdown, stop at the side of the road without endangering other road users and mark the stopping place in accordance with traffic regulations.

- The tractor operator is required to equip the trailer with an approved or approved warning reflective triangle.
- When travelling on public roads, the trailer must be marked with a slow-moving vehicle warning sign on the rear wall of the load box.
- When driving on public roads, comply with the road traffic regulations in force in the country where the trailer is used. Use direction indicators to signal a change of direction, keep clean and take care of the technical condition of lighting and signaling installations.
- Damaged or lost lighting and signalling components must be repaired or replaced immediately.
- Avoid ruts, depressions, ditches, or driving along roadside slopes. Driving across such obstacles can cause the trailer and tractor to tilt suddenly. This is particularly important because the centre of gravity of a trailer with a load (and especially with a volumetric load) adversely affects driving safety. Driving near the edge of ditches or canals is dangerous due to the risk of landslides under the wheels of the trailer or tractor.
- Reduce speed before cornering, when driving on uneven or sloping terrain.
- When driving, avoid sharp turns, especially on slopes.
- It should be remembered that the braking distance of the set increases significantly with the increase in the weight of the transported load and the increase in speed.
- Control the behaviour of the trailer while driving on uneven terrain. Adjust speed to terrain and road conditions.
- The trailer is adapted for driving on slopes up to a maximum of 8°.

Driving with trailer on steeper slopes may cause the



CAUTION

Travel with a high-volume load through ruts, ditches, slopes, etc. poses a high risk of overturning the trailer. Be especially careful.

trailer to tip over as a result of loss of stability. Prolonged driving on slopes creates the risk of losing braking efficiency.

OBS.3.I-004.01.EN

5.6 USE OF TIRES

- When working with tires, the machine should be secured against rolling by placing chocks under the wheels. Wheels can be taken off the trailer only when the trailer is not loaded.
- Repair work on wheels or tires should be carried out by persons trained and authorized to do so. These works should be carried out using appropriately selected tools.
- Checking the tightening of the wheel nuts carry out after the first use of the trailer, every 2- 3 hours during the first month of using the machine and then every 30 hours of driving. Always repeat all operations if the wheel was disassembled. Wheel nuts should be tightened in accordance with the recommendations contained in the *Inspections and technical service* chapter.
- Regularly check and maintain proper tire pressure as recommended in the instructions (especially after a long break in the trailer use).
- Tire pressure should also be checked during all-day intensive work. Take into account that an increase in tire temperature can increase the pressure by up to 1 bar. With this increase in temperature and pressure, reduce the load or speed of the trailer.
- Never reduce the pressure by venting if it increases due to temperature.
- Valves must be secured with appropriate caps to avoid soiling.
- Do not exceed the maximum trailer speed.
- During the whole day cycle, take a minimum of one hour break at noon.

- Observe 30 minutes breaks for cooling the tires after driving 75 km or after 150 minutes of continuous driving, whichever comes first.
- Avoid damaged surfaces, sudden and variable manoeuvres, and high speeds when turning.

OBS.3.8-010.01.EN

5.7 CLEANING



DANGER

Refer to the instructions for using cleaning detergents and preservatives.

When washing with detergents, wear suitable protective clothing and eye protection.

When cleaning the machine and staying on the cargo box, the tractor engine must be turned off, the articulated telescopic shaft must be disconnected.

Every day, after finishing, thoroughly clean the trailer of the remains of the transported material. If you use a pressure washer, learn about the principle of operation and recommendations for safe operation of this device.

Guidelines for cleaning the trailer

- Stop the tractor and trailer on a flat, even surface.
- Turn off the tractor engine and remove the ignition key.
- Secure the trailer and tractor with the parking brake, place wedges under the manure spreader wheel.
- Secure the tractor against unauthorized persons.
- Clean and wash the trailer with a strong stream of water and allow to dry in a dry and ventilated place.

The use of pressure washers increases the effectiveness of washing, but be careful when work. During washing, the nozzle of the cleaning aggregate must not be closer than 50 cm from the surface being cleaned.

The water temperature should not exceed 55°C.

Paint damage may occur when washing with excessive pressure.

Do not direct the water jet directly at the system components and trailer equipment, i.e. the control valve, brake cylinders, pneumatic, electric and hydraulic plugs, lights, electrical connectors, information and warning decals, data plate, conduit connections, lubrication points, etc. high water pressure may cause mechanical damage to these components.

- For cleaning and maintenance of plastic surfaces, use clean water or specialized preparations intended for this purpose.

**CAUTION**

Each time the work with trailer is finished, clean the trailer of the remains of the transported material.

After washing, wait for the machine to dry and then apply grease to all lubrication points as recommended. Wipe off excess grease or oil with a dry cloth.

During work, use appropriate, close-fitting protective clothing, gloves and the right tools.

- Do not use organic solvents, preparations of unknown origin or other substances that may damage the lacquered, rubber or plastic surface. Perform test on an invisible surface in case of doubt.
- Surfaces oily or greasy should be cleaned with petrol or degreasing agents, and then washed with clean water and detergent. Follow the cleaning agent manufacturer's instructions.
- Detergents intended for washing should be stored in their original containers, or alternatively, but marked exactly. The preparations cannot be stored in containers intended for storing food and beverages.
- Observe environmental protection principles, wash trailer in designated places.
- Washing and drying the trailer must take place at temperatures above 0 °C.

In winter, frozen water can cause damage to the paint coat or machine components.

OBS.3.8-011.01.EN

5.8 STORAGE

After finishing work, carefully clean and wash the machine.

In the event of damage to the paint coating, damaged areas must be cleaned of rust and dust, degreased, and then painted with paint while maintaining a uniform colour and uniform thickness of the protective coating. Until painting, damaged areas shall be covered with a thin layer of grease, anti-corrosive agent or primer.

It is recommended that the machine be stored indoors or under a roof.

For long-term storage outside the room, it must be protected against the effects of weather conditions, especially factors causing corrosion of steel and accelerating the aging of tires.

In the event of a longer stop, it is necessary to lubricate all points regardless of the period of the last treatment.

Wash and dry the rims and tires. During longer storage, it is recommended to move the machine once every 2-3 weeks so that the place of contact of the tire with the ground is in a different position. The tires will not deform and will maintain proper geometry. You should also check your tire pressure from time to time, and if necessary inflate the wheels to the correct value.

Store the articulated telescopic shaft for connecting to the tractor in a horizontal position.

OBS.3.8-012.01.EN

PERIODIC INSPECTIONS AND TECHNICAL MAINTENANCE

PRONAR TD218

6.1 GENERAL



CAUTION

It is forbidden to use a damaged machine.

Repairs during the warranty period may only be carried out by authorized service centres.

When using the trailer, it is necessary to constantly check the technical condition and perform maintenance procedures that will allow the machine to be kept in good technical condition. Mandatory perform all maintenance and regulatory activities specified by the manufacturer in accordance with the assumed schedule.

Repair of the during the warranty period may only be carried out by Authorized Sales and Service Points (APSiO). The machine's warranty inspection is only carried out by authorized service centres.

In the event of unauthorized repairs, changes to factory settings or activities that have not been considered as being possible by the trailer operator (not described in this manual), the user loses the warranty. Detailed information on the review schedule can be found in chapter entitled "*Maintenance and inspection schedule*".

After the warranty expires, it is recommended that inspections be carried out by specialized repair workshops.

During work, use protective clothing and protective equipment suitable for requirements.

SER.3.B-001.01.EN

6.2 ENTERING AND STAYING IN HIGH-RISK AREAS



CAUTION

Depending on the type of work, use appropriate clothing and personal protective equipment.

During the normal operation of the trailer, it is often necessary to enter places where staying during the machine operation may cause serious injury or death to the operator. Situations that require entering and staying in such areas are:

- maintenance works,
- repair work,
- periodic and control inspections,
- removing of clogs, jamming mechanisms,
- cleaning of the trailer.

Persons who must perform the above-mentioned activities are strictly obliged to comply with the following requirements, the fulfilment of which is absolutely necessary due to the high risk of an accident, if they are ignored.

- Before entering high-risk places, the trailer should be connected to the tractor and secured against unauthorized or accidental start-up.
- Secure the machine against rolling away.
- If necessary, use certified ladders and platforms.
- Before entering high-risk areas, take the key to start the tractor connected to the trailer with you and do not share it with anyone.
- Inform your co-workers about the planned work and the places where you will work.
- Never work alone. One additional person should stay outside the high risk zone.

Follow local labour laws.

SER.3.I-001.01.EN



DANGER

Before entering high-risk places, the trailer should be hitched to the tractor, the tractor turned off, the key removed from the ignition switch, the tractor cabin closed.

6.3 MAINTENANCE AND INSPECTION SCHEDULE

Table 6.1. Inspection categories

Item	Description	Performs	Frequency
A	Daily review	Operator	Inspection carried every day before first start-up or every 10 hours of continuous shift work.
B	Maintenance	Operator	Inspection performed periodically every 1000 kilometers driven or every month of trailer operation, whichever comes first. Each time before carrying out this inspection, a daily inspection should be performed.
C	Maintenance	Operator	Inspection performed periodically every 3 months. Before each performance of this inspection, a daily inspection should be performed and a monthly inspection of the trailer should be performed.
D	Maintenance	Operator	Inspection performed periodically every 6 months. Before each performance of this inspection, it is necessary to perform a daily inspection, inspection every 1 month of using the trailer and inspection every 3 months.
E	Maintenance	Operator	Inspection performed periodically every 12 months. Before each performance of this inspection, it is necessary to perform a daily inspection, inspection every 1 month of using the trailer and inspection every 3 months.
F	Warranty	Service	Inspection carried out for a fee after the first 12 months of use of the trailer, after reporting the owner.
G	Maintenance	Service ⁽¹⁾	Inspection performed every 4 years of trailer use

(1) - post-warranty service

Table 6.2. Technical inspection schedule

Description of activities	A	B	C	D	E	F	G	Page
Checking of the trailer before driving off	•							6.7
Tank drainage	•							6.9
Checking of plugs and connection sockets	•							6.10
Air pressure measurement, tire and rim inspection		•						6.12
Cleaning of the air filters			•					6.14
Checking of brake lining wear				•				6.15
Checking of the clearance of the axle bearings				•				6.16
Checking of the mechanical brakes				•				6.18
Cleaning of the drainage valve				•				6.20
Checking the tightness of the hydraulic system		• (1)			•			6.21
Checking and topping up of hydraulic oil	•							6.23
Change of the hydraulic oil						• (2)		6.24
Hydraulic system filters replacement						• (2)		6.26
The pneumatic system inspection					•			6.27
Checking of the fifth wheel coupling	<i>See: The manufacturer's manual for the fifth wheel coupling</i>							-
Pneumatic suspension control	<i>See table: Suspension control schedule</i>							6.34
Lubrication	<i>See table: Trailer lubrication schedule</i>							6.44
Checking the tightness of screw connections	<i>See table: Schedule for tightening of the critical bolted connections</i>							6.28
Replacement of hydraulic hoses							•	6.33
<i>(1) - first inspection;</i>								
<i>(2) - after every 1000 working hours or once a year, whichever occurs first</i>								

Table 6.3. Control parameters and settings

Description	Value	Notes
Breaking system		
Piston rod stroke in pneumatic systems	25 - 45 mm	
Minimum brake lining thickness	5 mm	
An angle between the expander axis and the fork	90°	With the brake applied

SER.3.I-002.01.EN

6.4 CHECKING OF THE TRAILER BEFORE DRIVING



DANGER

Driving with faulty lighting or brake system is prohibited.

In the event of damage to the trailer, do not use it until it is repaired.

Before connecting trailer to the tractor make sure that the hydraulic and pneumatic conduits are not damaged.

Check the completeness, technical condition and correct functioning of the trailer lighting.

Check the cleanliness of all electric lamps and reflectors.

Before travelling on a public road, remove the rear lamp covers and place them in the designated place.

Check the correct mounting of the triangular sign holder for slow moving vehicles and the plate itself.

Make sure that the tractor has a reflective warning triangle.

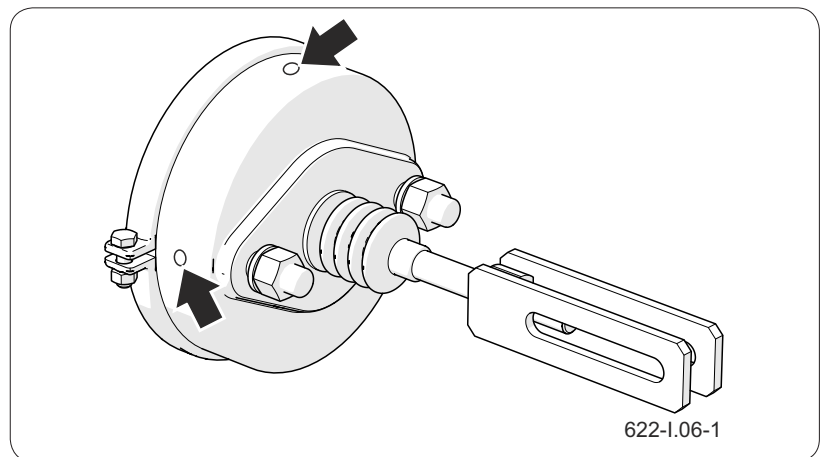

Figure 6.1 Brake cylinder

Check that the actuator ventilation openings are not clogged with dirt and that there is no water or ice inside. Check the correct mounting of the actuator.

Clean the actuator if necessary. In winter, it may be necessary to defrost the actuator and remove the accumulated water through the blocked vents. If any damage is found, replace the actuator. When mounting the actuator, keep its original position relative to the bracket.

While moving off, check the operation of the main

brake system. For proper operation of the pneumatic system, an appropriate level of air pressure in the trailer air tank is required.

Before driving, check the condition of the trailer's locking mechanism and that the coupling with the semi-trailer is correct. Check the lubrication of the pin, coupling and ramp plate of the semi-trailer.

Check tire pressure, tire condition and wear.

In the autumn and winter period check the drainage of compressed air tanks before driving.

Check the correct operation of the other systems while operating the trailer.

SER.3.I-003.01.EN

6.5 AIR RESERVOIR DRAINING



DANGER

During each inspection of the trailer and after periods of cleaning the tank, pay particular attention to the durability of its mounting to the trailer and general technical condition. In the event of any irregularities, the defect must be removed immediately.

Dismantling of the tank or its components is prohibited when it is under pressure.

- Press the stem of the drain valve (1) located at the bottom of the tank (2).

The compressed air in the tank will remove water outside.

- After releasing the spindle, the valve should automatically close and stop air flow from the tank.
- If the valve stem does not want to return to its position, wait until the tank empties. Then unscrew and clean or replace the valve with a new one.
- If it is necessary to clean the drain valve, follow the chapter “*Cleaning the drain valve*”.

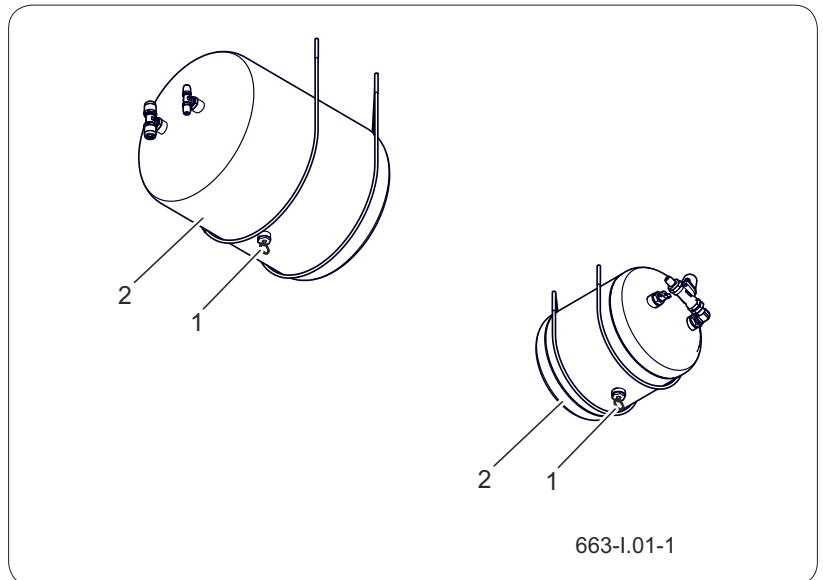

Figure 6.2 Air reservoir
(1) drain valve (2) air reservoir

SER.3.I-004.01.EN

6.6 CHECKING PLUGS AND CONNECTION SOCKETS

A damaged body of the hydraulic or pneumatic hose connector or socket qualifies them for replacement. In the event of damage to the cover or gasket, replace these elements with new, functional ones. Contact of pneumatic connection seals with oils, grease, gasoline etc. may damage them and accelerate the aging process.

If the trailer is disconnected from the tractor, connections should be protected with covers or placed in their designated sockets. Before the winter period,

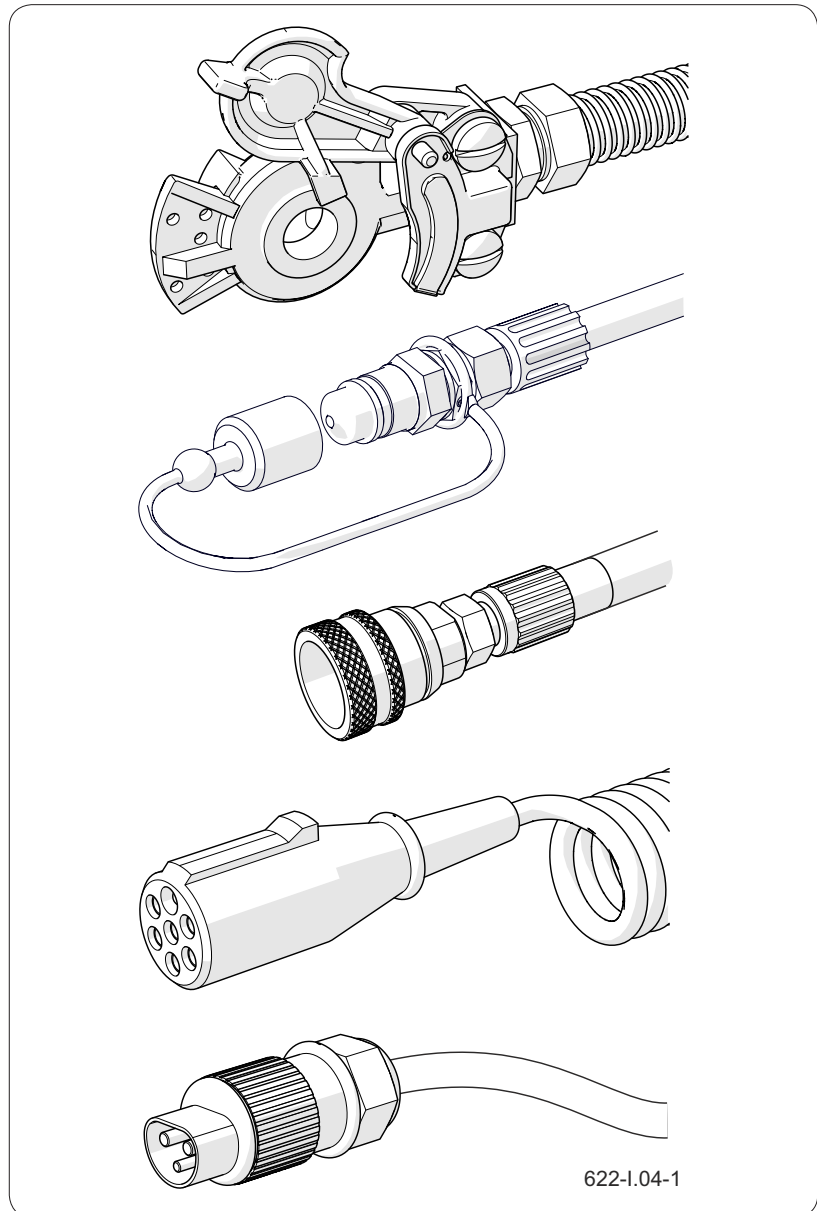

Figure 6.3 Checking the trailer connections

it is recommended to preserve the seal with preparations intended for this purpose (e.g. silicone lubricants for rubber elements).

Each time before connecting the machine, check the technical condition and degree of cleanliness of connections and sockets on the agricultural tractor. If necessary clean or repair tractor sockets.

SER.3.8-005.01.EN

6.7 MEASUREMENT OF AIR PRESSURE, CHECK TIRES AND WHEELS

ADVICE

In the event of intensive use of the trailer, we recommend more frequent pressure checks



CAUTION

Using the trailer in which tires are not properly inflated may lead to permanent damage to the tire as a result of delamination of the material. Incorrect tire pressure also causes faster tire wear.

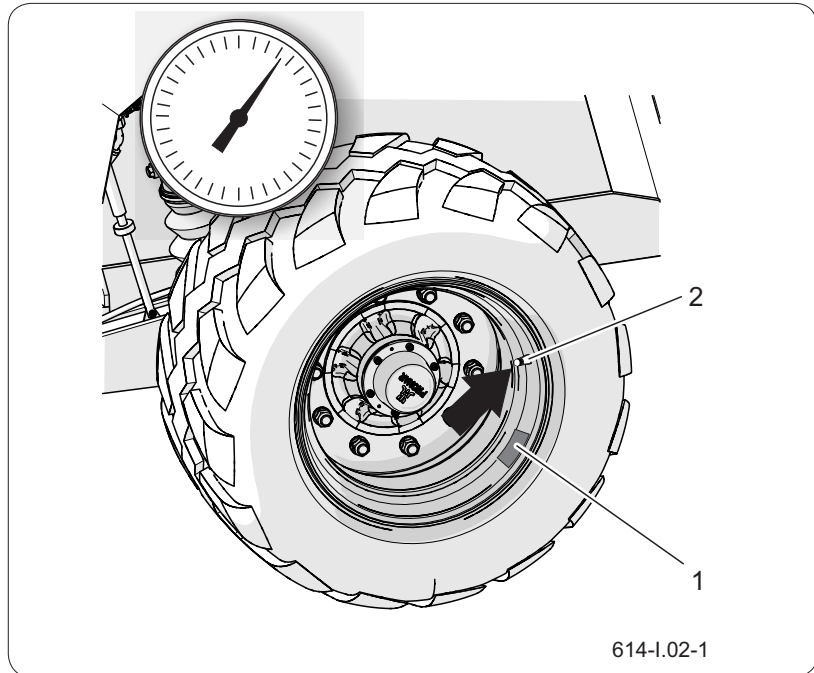

Figure 6.4 Trailer wheel
(1) sticker (2) valve

During pressure measurement the trailer must be unloaded. Checking should be carried out before driving, when the tires are not warm, or after a long standstill of the trailer.

The scope of activities

- Connect the pressure gauge to the valve.
- Check the air pressure.
- If necessary, inflate the wheel to the required pressure.
- The required air pressure is described on a sticker (1) on the rim.
- Check the tread depth.
- Check the side wall of the tire.
- Inspect the tire for defects, cuts, deformations, bumps indicating mechanical damage to the tire.
- Check that the tire is correctly positioned on the rim.
- Check the tire age.

When checking pressure, pay attention to the technical

condition of rims and tires. In the event of mechanical damage, consult your nearest tire service centre and ensure that your tire defect is eligible for replacement. Rims should be checked for deformation, material cracks, weld cracks, corrosion, especially around welds and in the place contact with the tire.

SER.3.8-007.01.EN

6.8 CLEANING THE AIR FILTERS

The scope of activities

- Reduce pressure in the supply line.

The pressure in the pipe can be reduced by pushing the plug of the pneumatic connection as far as it will go.

- Slide out the filter lock (1).

Hold the filter cover (2) with your other hand. After removing the slide, the cover will be pushed out by the spring located in the filter housing.

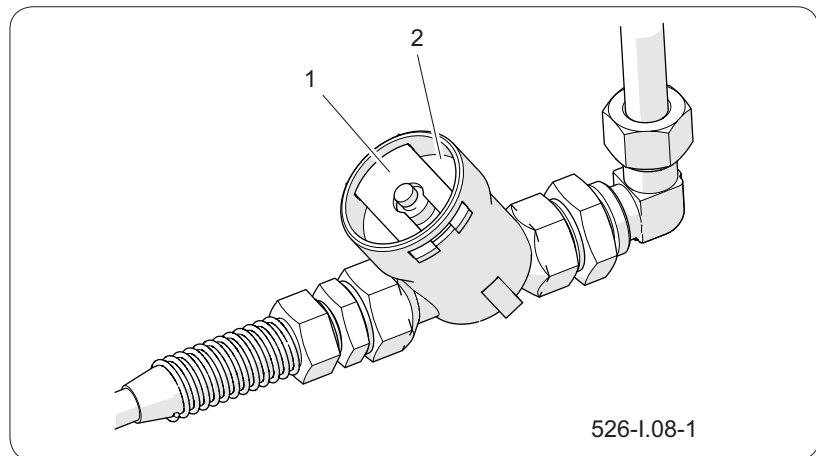

Figure 6.5 Air filter
(1) filter (2) cover

- The cartridge and the filter body should be thoroughly washed and blown out with compressed air. Installation should be made in reverse order.

SER.3.8-008.01.EN

6.9 CHECKING BRAKE LINING WEAR

ADVICE

Brake lining wear control,

- according to the schedule of inspections,
- if the brakes overheat,
- the stroke of the brake cylinder piston significantly increases,
- in the event of unnatural noises coming from around the road axle drum.

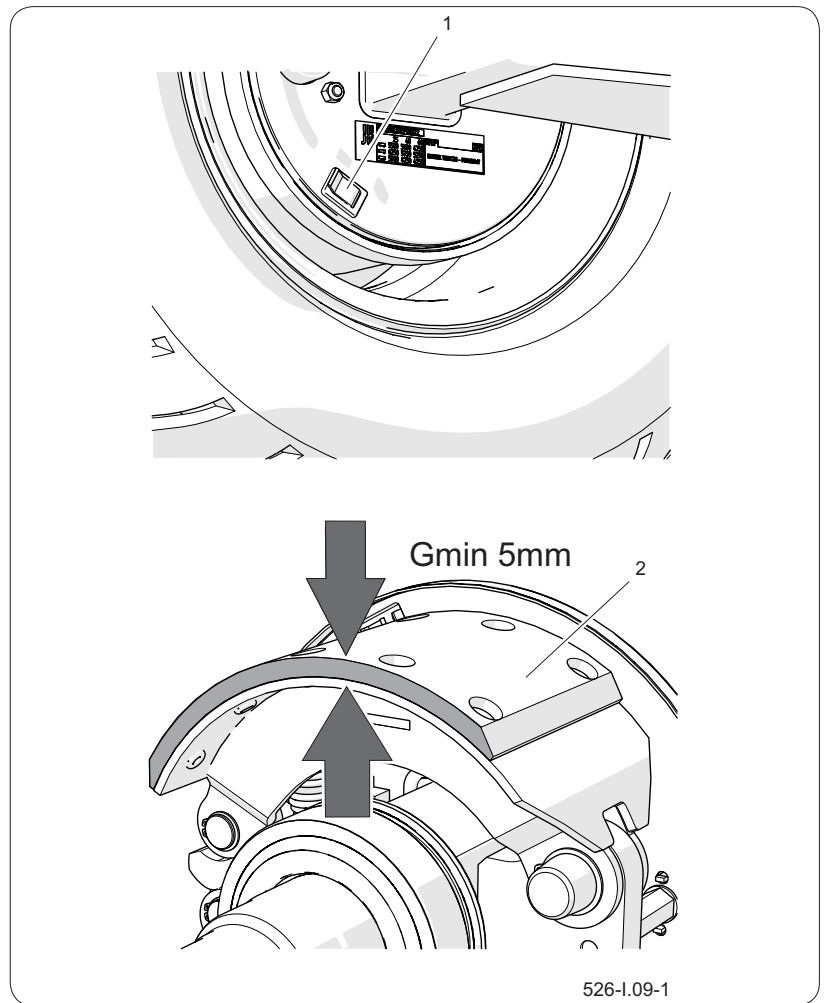

Figure 6.6 Checking the brake lining thickness
(1) blanking plug (2) brake lining

- Find the inspection hole.
Depending on the version of the road axle, the inspection hole may be located in a different place than the figure shows, but it will always be located on the brake shield.
- Remove the upper and lower plugs and then check the thickness of the lining.
- The brake shoes must be replaced if the thickness of the brake lining is less than 5 mm.
- Check the the remaining linings for wear.

SER.3.8-009.01.EN

6.10 CHECKING THE CLEARANCE OF THE AXLE BEARINGS

ADVICE

Damaged hub cover or lack thereof will cause the penetration of dirt and moisture into the hub, which will result in much faster wear of bearings and hub seals.

Bearing life depends on trailer operating conditions, load, vehicle speed and lubrication conditions.



DANGER

Before starting work, read the jack User's Manual.

Ensure that the machine will not roll when checking the looseness of the axle bearings.

Perform a clearance control of the bearings only and only when the machine is connected to the tractor, and the load box is empty and is not raised.

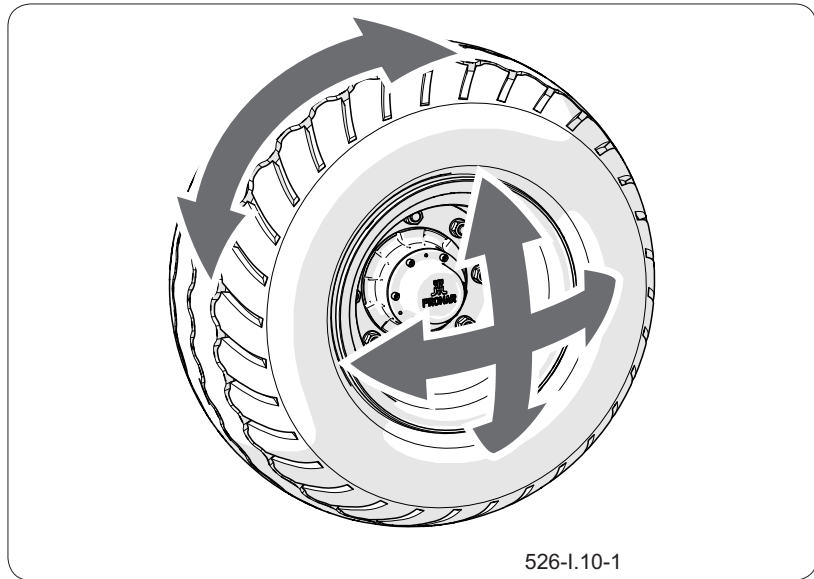

Figure 6.7 Clearance inspection

- Raise the wheel with a jack.
- Turn the wheel slowly in two directions. Check that the movement is smooth and the wheel rotates without excessive resistance and jamming.
- Turn the wheel so that it rotates very quickly, check that the bearing does not make any unusual sounds.
- Try to feel looseness by moving the wheel.
- Repeat steps separately for each wheel.

Remember that the lift must be on the opposite side of the wedges!

- If looseness is felt, adjust the bearings. Unnatural sounds coming from the bearing may be symptoms of excessive wear, dirt or damage. In this case, the bearing together with the sealing rings should be replaced or cleaned and re-greased. When checking bearings, make sure that any noticeable looseness comes from the bearings, not the suspension system (e.g. looseness on the spring pins, etc.).

- Check the the technical condition of the hub cover, replace if necessary.

SER.3.8-010.01.EN

6.11 CHECKING OF MECHANICAL BRAKES

ADVICE

Checking the technical condition of the brakes:

- according to the schedule of inspections,
- before the period of intensive use.
- after repairing the braking system.
- in the event of uneven braking of the trailer wheels.

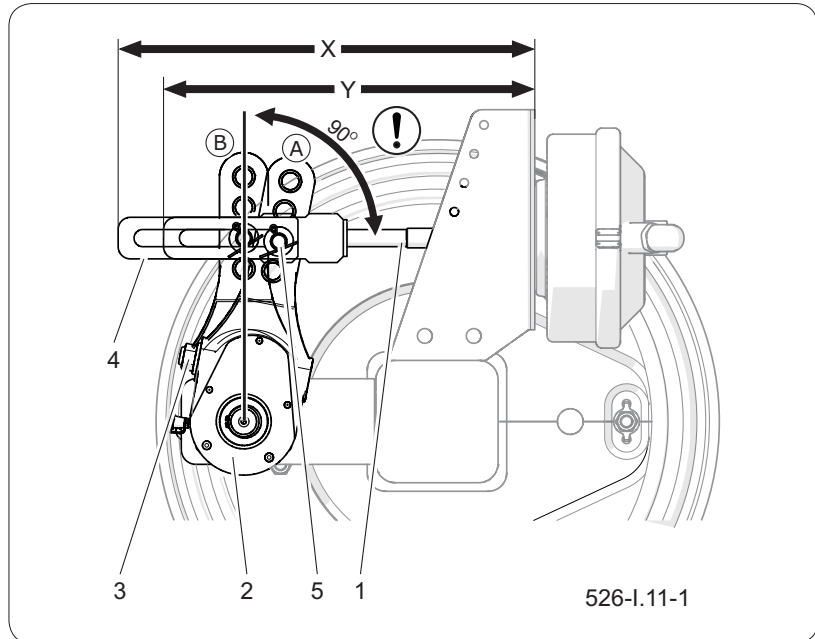

Figure 6.8 Brake check
 (1) cylinder piston (2) expander arm
 (3) adjustment screw (4) of the cylinder fork
 (5) pin position
 (A) position of the arm in the released position
 (B) arm position in braking position

In a correctly adjusted brake the cylinder piston stroke brake should be within the range given in Table 6.3 and depends on the type of cylinder used. When the wheel is fully braked, the optimal angle between the expander lever and the piston rod should be approx. 90 °. With this setting, the braking force is optimal. Checking the brakes consists in measuring this angle and the piston rod stroke in each wheel.

The scope of activities

- Measure the distance X with the tractor brake pedal released.
- Measure the distance Y with the tractor brake pedal pressed.
- Calculate the distance difference X-Y (rod stroke).
- Check the angle between the cylinder piston axis and the expander lever.

- If the expander arm angle (2) and piston rod stroke exceed the range given in table 5.3, the brake should be adjusted.

SER.3.8-011.01.EN

6.12 CLEANING OF THE DRAINAGE VALVE



DANGER

Bleed the air reservoir before removing the drain valve.

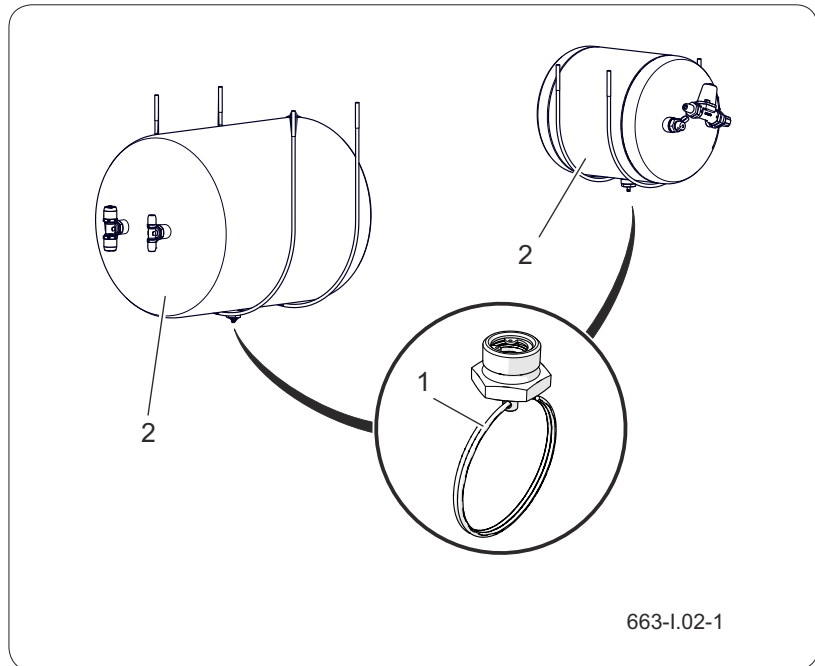

Figure 6.9 Air reservoir
(1) drain valve (2) tank

The scope of activities

- Fully reduce the pressure in the air reservoir (2).
The pressure in the tank can be reduced by swinging the drain valve stem.
- Unscrew the valve (1).
- Clean the valve, blow with compressed air.
- Replace the gasket.
- Screw in the valve, fill the tank with air, check the tank for leaks.

SER.3.8-012.11.EN

6.13 CHECKING THE TIGHTNESS OF THE HYDRAULIC SYSTEM



DANGER

It is forbidden to use the machine with inefficient braking system.



CAUTION

Before starting the trailer's hydraulic system, fill the PTO driven pump with oil from the tank - do not run dry.

- Connect the trailer to tractor. Connect the articulated telescopic shaft and hydraulic system conduits according to the recommendations of the User's Manual.
- Clean hose connections and couplings.
- Start the PTO drive and then the hydraulic system.

The ball valve (1) must be in the open position. The hydraulic system manifold is controlled by means of the remote control (2) or the manifold lever (3) - lifting and lowering.

- Check the hydraulic system for leaks.

In the event of presence of the oily substances on the hydraulic system components, check the nature of the leak.

Small leaks with symptoms of "sweating" are permissible. When you notice "droplets" type leaks do not use the machine until the fault is removed.

If visible moisture appears on the cable connectors tighten the the connector with a specified torque and

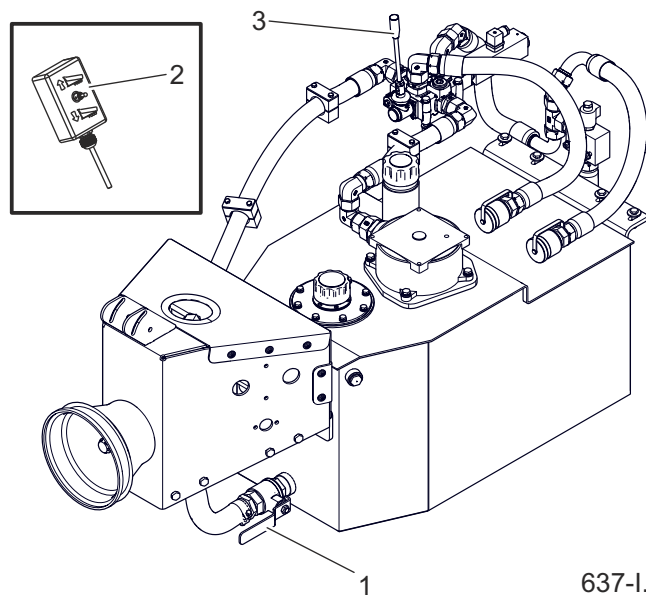

637-I.01-1

Figure 6.10 Hydraulic system
(1) ball valve (2) remote control
(3) manifold lever

carry out the test again. If the problem persists replace the leaking element.

Control of the technical condition of hydraulic connectors

Hydraulic couplings must be technically efficient and kept clean. Each time before connecting, make sure that the sockets are kept in good condition. The hydraulic systems of the trailer are sensitive to the presence of solid contaminants, which may cause damage to precise elements of the installation (jamming of hydraulic valves, etc.)

SER.3.I-005.11.EN

6.14 CHECKING AND TOPPING UP OF HYDRAULIC OIL

ADVICE

The hydraulic system with the oil tank has been filled with L-HL32 PN-91/L-96067/04 hydraulic oil.



CAUTION

Always check the oil level in the system before starting the machine.

Perform the oil level check with the machine turned off, the oil should be cooled down.

If you notice an oil leak, carefully inspect seals, hydraulic lines, couplings; check the oil level.



DANGER

During work related to the control and refilling of oil, use appropriate personal protective equipment, i.e. protective clothing, shoes, gloves, glasses. Avoid oil contact with skin.

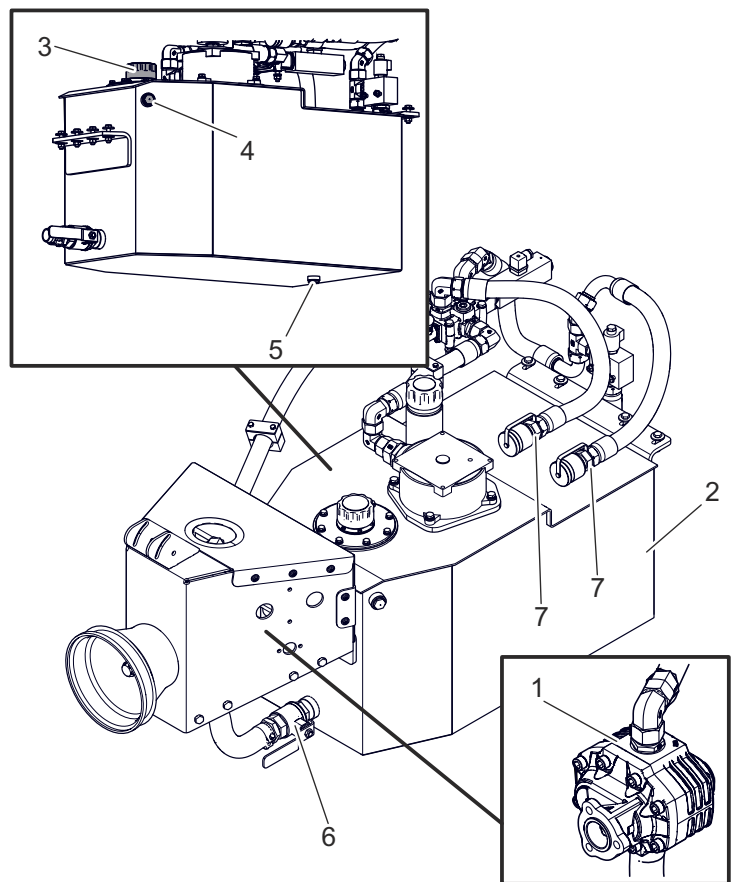

637-I.02-1

Figure 6.11 Oil level control

- (1) gear pump (2) oil reservoir
 (3) filler plug with filter (4) oil sight glass (oil gauge)
 (5) drain plug (6) ball valve
 (7) quick coupler socket

Checking the oil level in the hydraulic system with an oil tank

- Level the machine up and block it with the parking brake and chocks.
- Check the oil level in the reservoir (2) through the transparent oil sight glass (4).
- If necessary, unscrew the oil filler plug (8) and add oil to the required level. Tighten the oil filler cap.

The oil level should be at the halfway point of the sight glass.

SER.3.I-006.11.EN

6.15 HYDRAULIC OIL REPLACEMENT

ADVICE

The hydraulic system with the oil tank has been filled with L-HL32 PN-91/L-96067/04 hydraulic oil.

Installation capacity 150l. After filling the system, add oil in the tank to the required level on the sight glass.

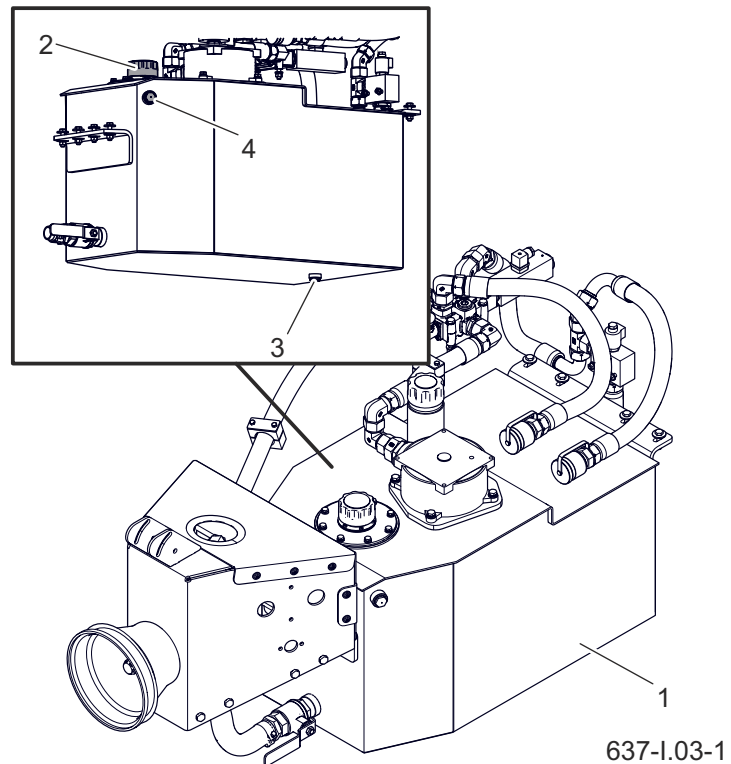

Figure 6.12 Oil change

(1) oil tank (2) filler plug with filter

(3) drain plug (4) oil sight glass (oil gauge)

- Level the machine up and block it with the parking brake and chocks.
- Prepare a container for used oil.
- Unscrew the filler cap (2) and pump the oil out of the reservoir through the filler hole using the oil suction pump.
- Drain the remaining oil at the bottom of the tank into a previously prepared vessel by unscrewing the drain plug (3).

It is possible to drain the hydraulic oil through the drain plug (3). In this case, make sure that the vessel is sufficiently large, bearing in mind the large amount of oil (~ 150l) in the oil tank.

- Close the drain plug(3).
- Replace filters before refilling oil.

- Check the cleanliness of the strainer in the filling opening, if necessary, blow it with compressed air.
- Pour in new oil to the required level and screw the plug (2).

The oil level should be at the halfway point of the sight glass.

- After the first use of the trailer after changing the oil, check the hydraulic oil level. If necessary, top up the oil level.
- Dispose of used oil in accordance with local regulations.

SER.3.I-007.11.EN

6.16 HYDRAULIC SYSTEM FILTERS REPLACEMENT



CAUTION

At the same time with each oil change in the tank, the suction filter (4) inside the tank and the oil filter (5) must be replaced.



CAUTION

When unscrewing the used suction filter or oil filter, do not use a hammer, chisel, etc., because the filter body may be damaged. Use filters recommended by the machine manufacturer (original).

Screw on the filter by hand, without using any other tools

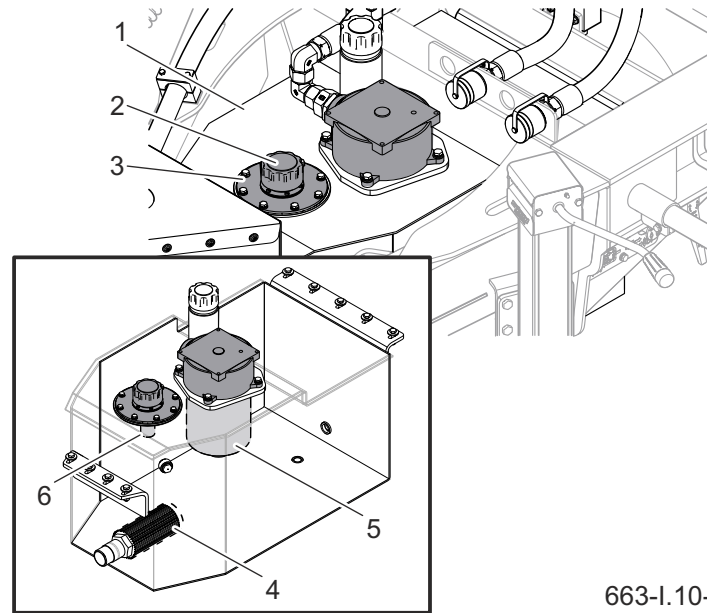

663-I.10-1

Figure 6.13 Oil filter replacement
 (1) oil tank (2) filler plug with filter
 (3) tank inlet cover (4) oil suction filter
 (5) oil filter (6) strainer

Carry out filter changes together with oil change in the tank:

- Unscrew the inlet cover (3) of the tank and unscrew the oil suction filter (4) through the opening in the tank.
If necessary, replace the cover gasket.
- The oil filter (5) is located in the oil return to the reservoir. To replace, unscrew the filter from the tank and replace the filter element.
- Check the cleanliness of the strainer (6) in the filling opening, if necessary, blow it with compressed air.
- Check the hydraulic oil level after changing the oil and filters and during daily checks. If necessary, top up the oil level.

SER.3.I-013.01.EN

6.17 CONTROL OF PNEUMATIC BRAKING SYSTEM



DANGER

It is forbidden to use the machine with inefficient braking system.



DANGER

Repair, replacement or regeneration of pneumatic system components may only be carried out in a specialized workshop.

The scope of activities

- Connect the trailer to tractor.
- Block the tractor and trailer with the parking brake. Put the wedges under one wheel of the rigid axis.
- Start the tractor to supplement the air in the trailer braking system tank.
- Switch off the tractor engine.
- Check the the system components with the tractor brake pedal released.
- Pay special attention to cable connections and brake cylinders.
- Repeat the system check with the tractor brake pedal depressed.

In the event of a leak, the compressed air will leak out in places of damage with a characteristic hiss. The leakage of the system can detect coating checked elements for washing or other foaming preparation, which will not interact aggressively to the elements of the installation. Damaged elements should be replaced or sent for repair. If the leak appeared around the connections, user can tighten the connector on their own. If the air continues to leak replace the elements of the connector or sealing into new ones.

When checking for leaks, pay attention to the technical condition and degree of cleanliness of the system components. Contact of pneumatic conduits, seals etc. with oil, grease, gasoline etc. may damage them or accelerate the aging process. Bisted, permanently deformed, cut or damaged wires should be replaced for new ones.

SER.3.8-016.01.EN

6.18 TIGHTENING TORQUES FOR SCREW CONNECTIONS

During maintenance and repair work, apply appropriate tightening torques to screw connections, unless other tightening parameters are given. Recommended tightening torques for the most commonly used bolted connections are shown in the Table. The given values apply to non-lubricated steel bolts.

The hydraulic hoses should be tightened with a torque of 50 -70Nm.

Check the tightness using a torque wrench. During daily inspection of the manure spreader pay attention to loose connections and tighten the connector if necessary. Replace lost items with new ones.

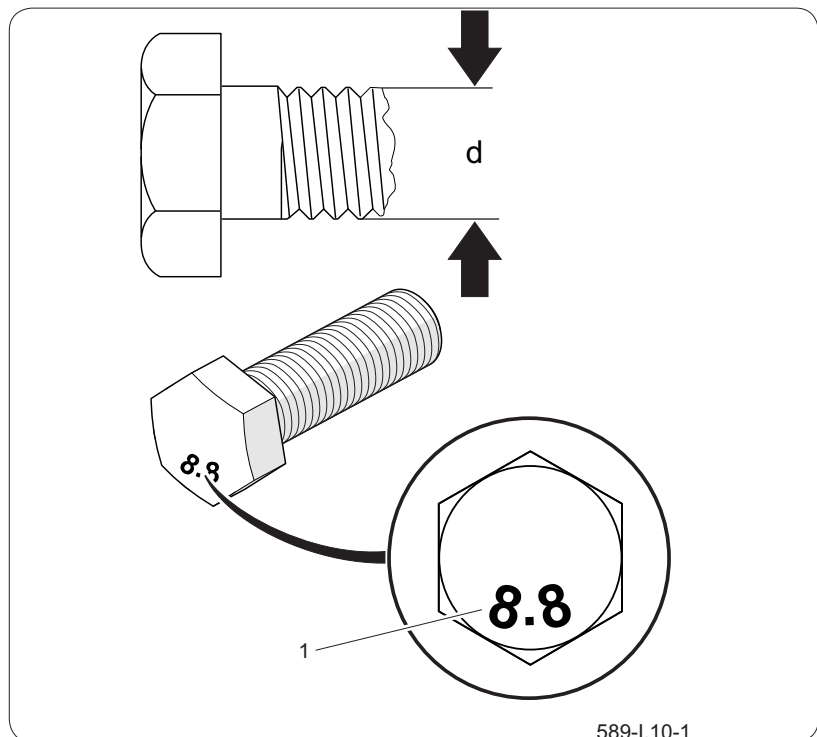

Figure 6.14 Metric thread screw
(1) strength class, (d) thread diameter

Table 6.4. Tightening torques for screw connections

Metric thread		
	8.8 ^(*)	10.9 ^(*)
M8	25	36
M10	49	72
M12	85	125
M14	135	200
M16	210	310
M20	425	610
M24	730	1,050
M27	1,150	1,650
M30	1,450	2,100

(*) - strength class according to DIN ISO 898

Table 6.5. Tightening torques of hydraulic elements

Thread of nuts	Wire diameter DN (inch)	Tightening torques [Nm]
M10x1 M12x1.5 M14x1.5	6 (1/4")	30÷ 50
M16x1.5 M18x1.5	8 (5/16")	30÷ 50
M18x1.5 M20x1.5 M22x1.5	10 (3/8")	50÷ 70
M22x1 M24x1.5 M26x1.5	13 (1/2")	50÷ 70
M26x1.5 M27x1.5 M27x2	16 (5/8")	70÷ 100
M30x1.5 M30x2 M33x1.5	20 (3/4")	70÷ 100
M38x1.5 M36x2	25 (1")	100÷ 150
M45x1.5	32 (1.1/4")	150÷ 200

SER.3.8-017.01.EN

6.19 TIGHTENING ROAD WHEELS

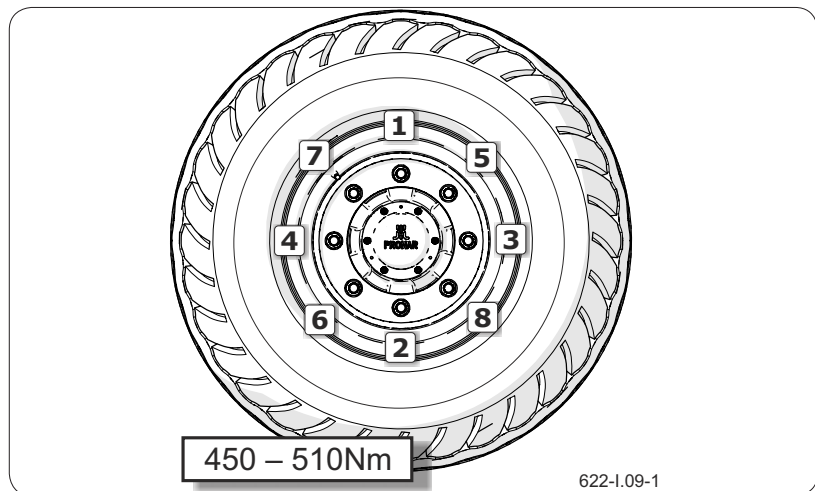

Figure 6.16 The order of the nuts tightening (8 pcs)

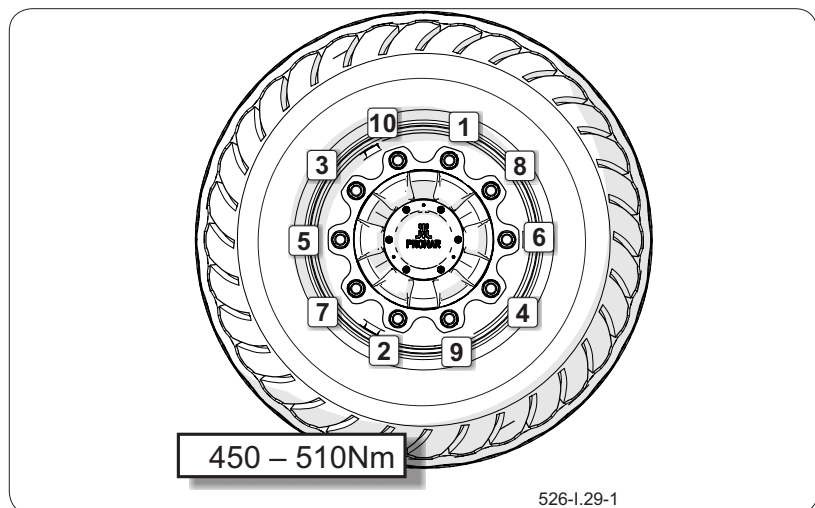

Figure 6.15 The order of the nuts tightening (10 pcs)

The wheel nuts be tightened gradually diagonally (in several stages until the required tightening torque is achieved), using a torque wrench. The recommended order of tightening of the nuts and the tightening torque is shown on the figures.

Wheel nuts must not be tightened with impact wrenches, due to the danger of exceeding the permissible tightening torque, which may result in breaking the connection thread or breaking the hub pin.

The wheels should be tightened according to the following scheme:

- after first use of the machine (one-time inspection),
- every 2-3 hours of driving during the first month of use,
- every 30 hours of driving.

If the wheel was disassembled, the above steps should be repeated.

SER.3.8-018.01.EN

6.20 TIGHTENING OF THE DRAWBAR EYE



CAUTION

As part of maintenance, lubricate the contact surfaces of the drawbar eye (see Trailer lubrication schedule) and check the tightness of the drawbar eye mounting bolts using a torque wrench (560 Nm).

Check the condition of the mechanical coupling devices. In the event of exceeding the abrasion limits of the drawbar eye opening (2.5 mm) or damage, replace the drawbar eye with a new one.

Coupling devices should be replaced by service personnel.

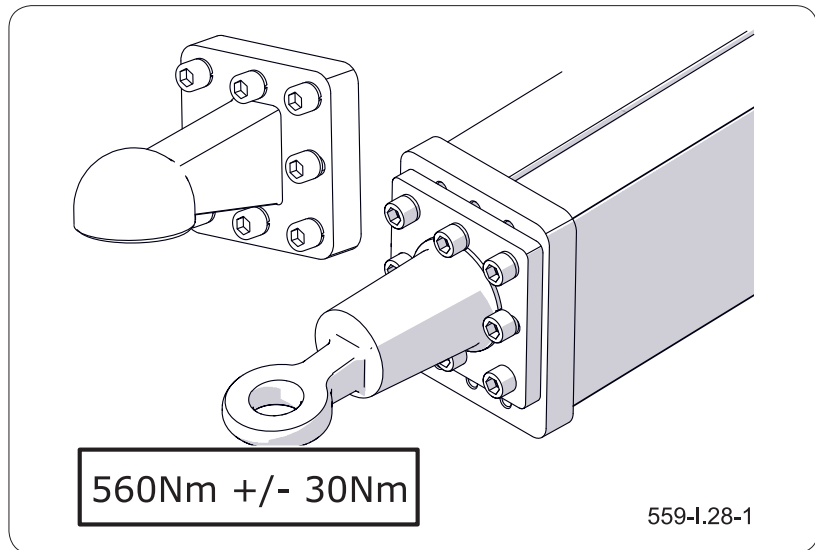

Figure 6.17 Tightening of the drawbar eye

Checking the tightness of the drawbar eye should be performed at the same time as checking the wheel nuts. The tightening torque of M20x80 bolts 10.9 class should be 560+/- 30 Nm. Tighten the screws diagonally with a torque wrench.

SER.3.8-019.02.EN

6.21 REPLACEMENT OF HYDRAULIC HOSES

- Rubber hydraulic hoses should be replaced every 4 years regardless of their technical condition. This operation should be entrusted to specialized workshops.

SER.3.8-020.01.EN

6.22 PNEUMATIC SUSPENSION CONTROL

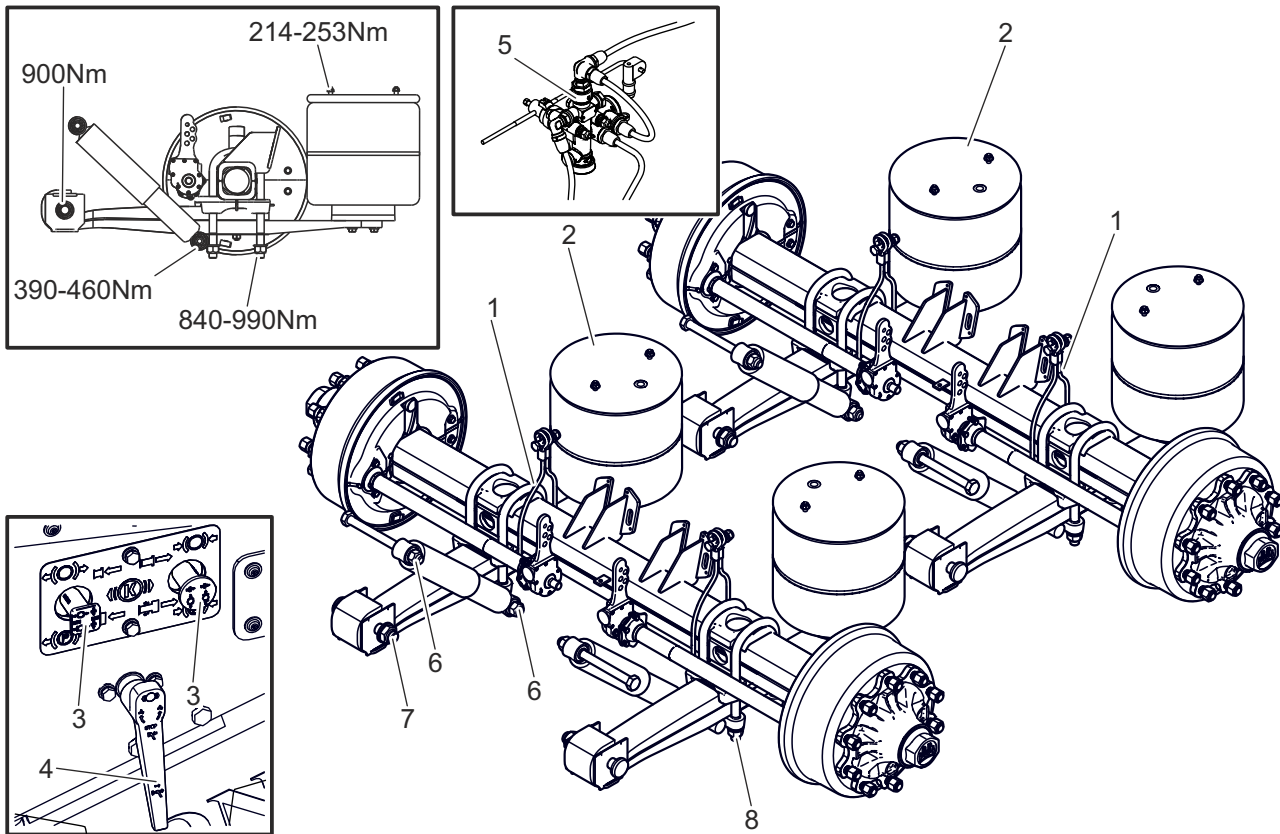

637-I.04-1

Figure 6.1 Pneumatic suspension handling



CAUTION

Tighten the bolt connections of the suspension under load. It is not allowed to use pneumatic wrenches when tightening. Tighten the screw connections with a torque wrench.

When checking the condition of the suspension, pay attention to the degree of wear of individual parts, play in the system and check that all elements are complete and show no signs of cracks or deformation. In the event that any of the suspension elements is damaged or shows excessive wear, stop using the trailer immediately, and replace or repair the damaged element.

Table 6.6. Suspension control schedule

Item	Maintenance activities	Frequency
1	Check the condition and fastening of the stroke limiting ropes (1), replace if necessary.	Once every 6 months.

Item	Maintenance activities	Frequency
2	<ul style="list-style-type: none"> - Inspection of the condition of the bellows (2) by visual inspection (surface cracks, abrasions, folds, etc.). If any damage is found, the bellows must be replaced. - Inspection of the technical condition of the bellows base for external damage, deformation and correct mounting. - Check the tightness of the bellows mounting bolts and nuts. 	Once every 6 months.
3	<p>Handling of the pneumatic suspension system</p> <ul style="list-style-type: none"> - Check the condition, tightness and fastening of valves and pipes in the installation. - Drainage of the air tank in the air suspension system. - Test the buttons (3) of the loosening-parking valve and the lifting / lowering valve lever (4). - Check the condition of the tie rods and levers of the leveling valve (5). 	Once every 6 months.
4	<p>Check the shock absorber mounting</p> <ul style="list-style-type: none"> - Check the tightness of the lower and upper shock absorber mounts (6) using a torque wrench. 	<p>Not less than once a year. For the first time after 2 weeks.</p>
5	<p>Spring pin inspection.</p> <ul style="list-style-type: none"> - Check the condition of the metal-rubber bushings by observing them while moving the vehicle forward and backward with the brake on or by moving the spring eye with the lever. In both cases there must be no play in the spring eye. - Check the tightness of the half spring pin nut (7). 	<p>Not less than once a year. For the first time after 2 weeks.</p>
6	<p>Check U bolts and spring yoke.</p> <ul style="list-style-type: none"> - Check the tightness of the nuts (8) and the condition of the support plates. The nuts should be tightened gradually "crosswise" so that the plates do not twist. 	<p>Not less than once a year. For the first time after 2 weeks.</p>

ADVICE

In the event of severe conditions of use or intensive use, maintenance activities should be performed more frequently.

SER.3.I-009.11.EN

6.23 ADJUSTING THE CLEARANCE OF THE AXLE BEARINGS



CAUTION

Adjusting the bearing looseness only be carried out when the trailer is connected to the tractor and the loading box is empty.

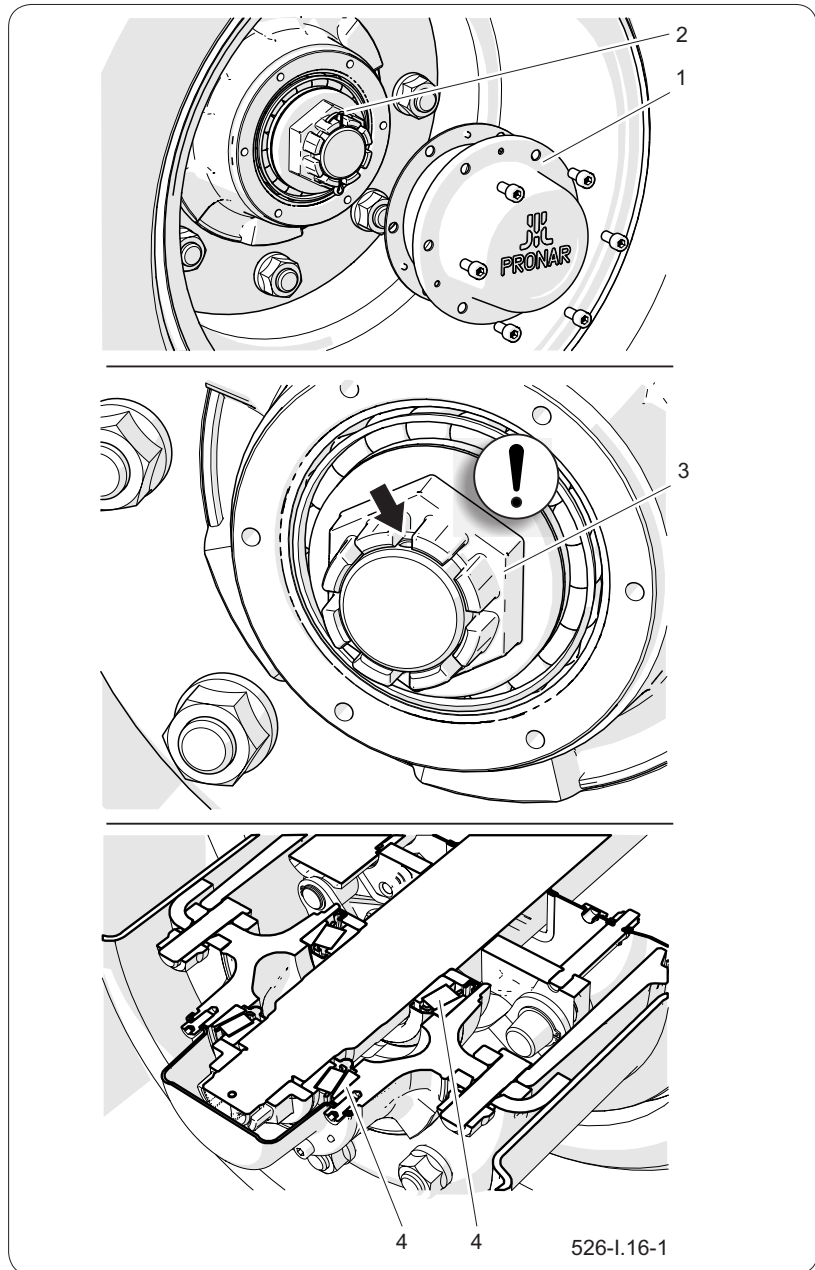

Figure 6.18 The principle of bearing clearance adjustment (1) hub cover, (2) cotter pin, (3) nut, (4) tapered roller bearing

The scope of activities

Prepare the tractor and machine for adjustment as described in chapter „Preparing of the machine”.

Remove the hub cover (1).

- Remove the cotter pin (2) securing the castellated nut (3).
- Tighten the the castellated nut to remove slack.

The wheel should rotate with slight resistance.

- Unscrew the nut (3) (not less than 1/3 of a turn) to cover the nearest groove of the nut with a hole in the journal of the axle (the pin's hole is marked with a black arrow in the drawing). The wheel should rotate without excessive resistance.

The wheel should rotate without excessive resistance. Too strong pressure is not recommended due to the deterioration of bearings.

- Secure the castellated nut with a cotter pin and mount the hub cover (1).
- Gently tap the hub with a rubber or wooden hammer.

SER.3.8-025.01.EN

6.24 BRAKE ADJUSTMENT

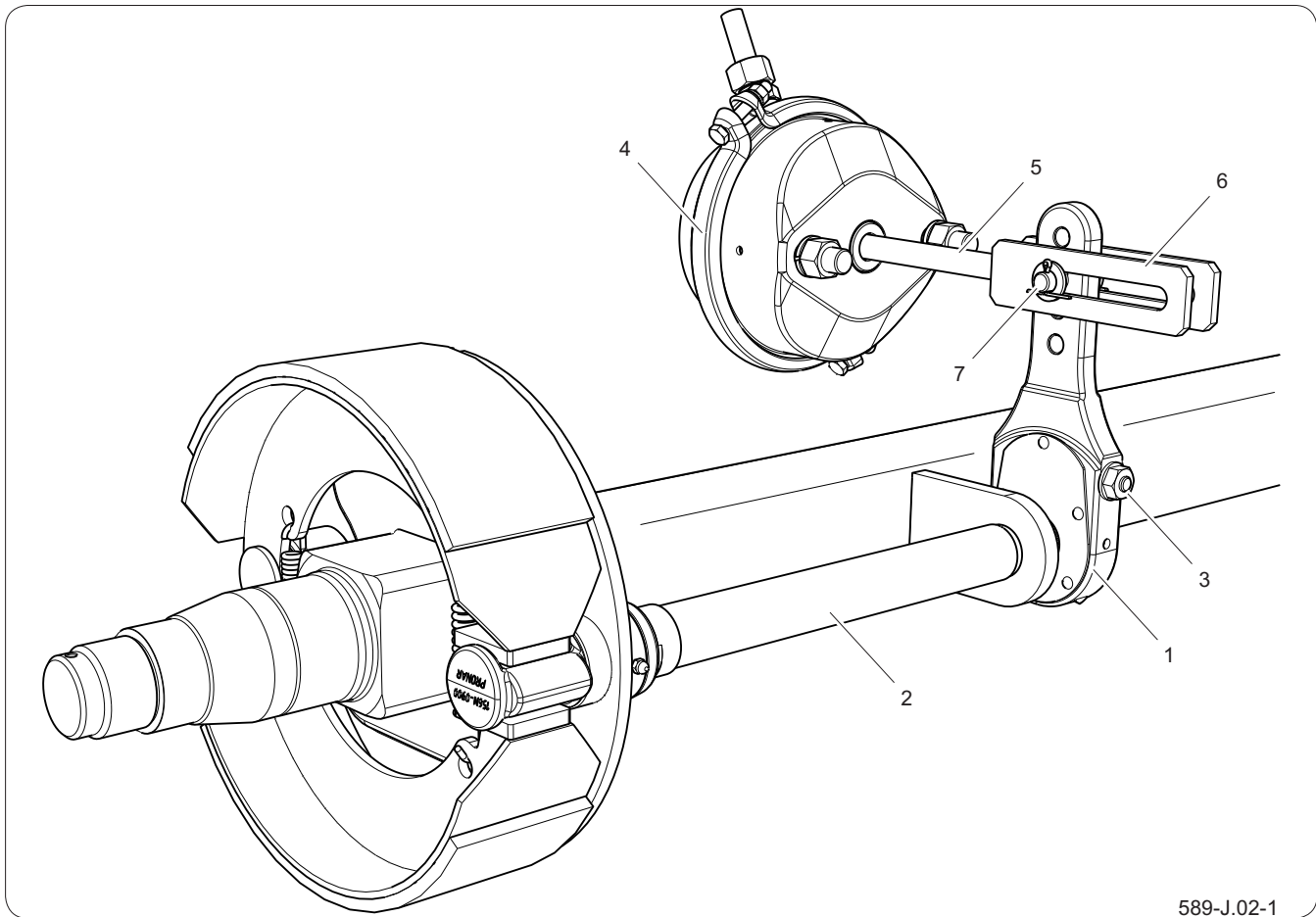

Figure 6.19 Construction of pneumatic axle brake

- | | | |
|-------------------------|---------------------|----------------------|
| (1) expander arm, | (2) expander shaft, | (3) adjusting screw, |
| (4) pneumatic cylinder, | (5) cylinder, | (6) cylinder fork, |
| (7) cylinder pin | | |

ADVICE

The correct stroke of the piston rod should be in the range of 25 -45 mm.

Significant wear of the brake linings increases the stroke of the brake cylinder piston and deteriorates braking performance.

When braking, the piston rod stroke should be within the specified working range, and the angle between the piston rod (1) and the expander arm (3) should be approximately 90° - Figure (6.6) i (6.7). The trailer wheels must brake simultaneously.

The braking force also decreases when the angle of operation of the brake cylinder piston rod (5) is not correct - figure (6.4), (6.5) in relation to the expander arm (1). To obtain the optimum mechanical angle of

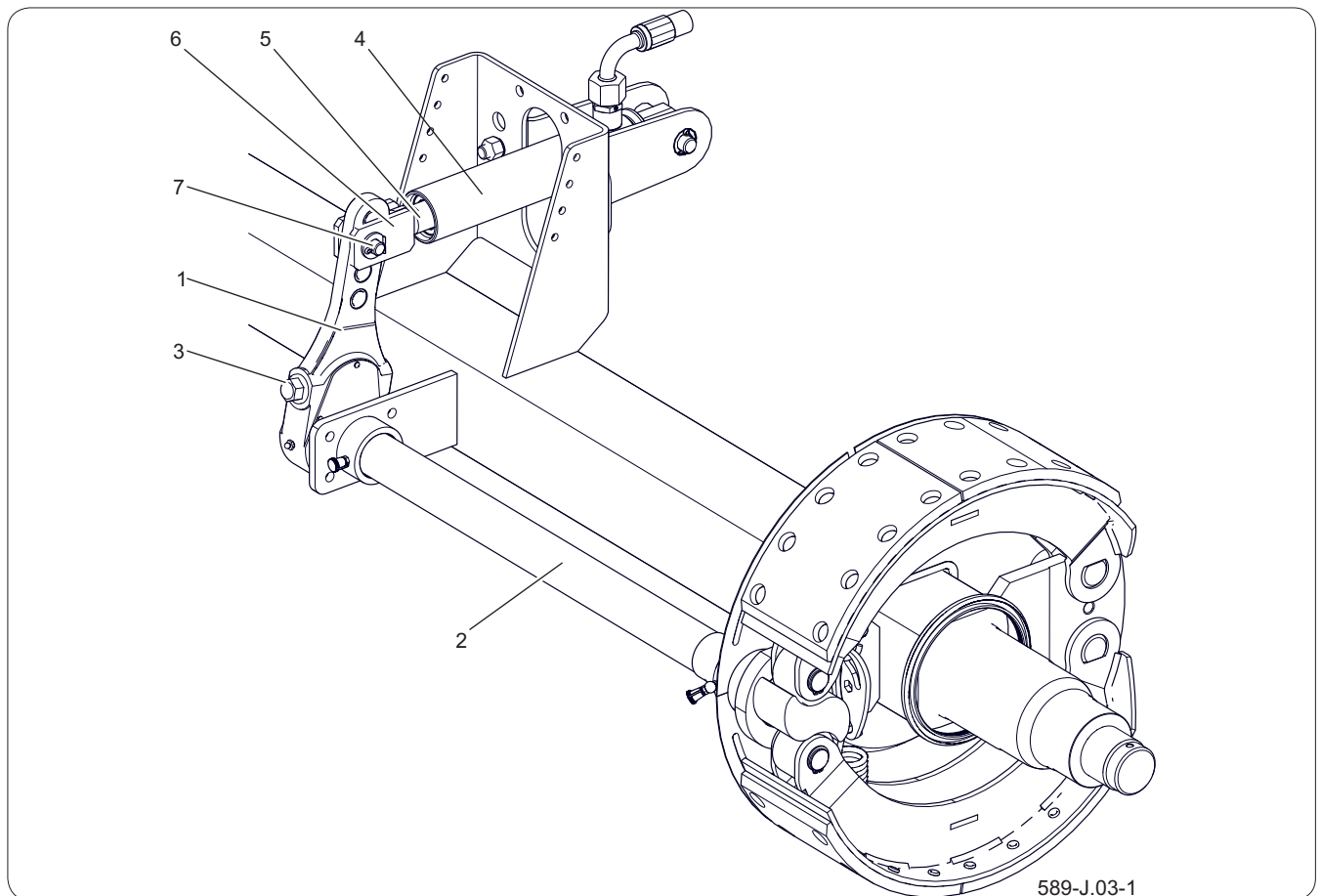

Figure 6.20 Construction of hydraulic axle brake
 (1) expander arm, (2) expander shaft, (3) adjusting screw,
 (4) hydraulic cylinder, (5) cylinder piston rod, (6) cylinder fork,
 (7) cylinder pin



CAUTION

An improperly adjusted brake can cause the rubs to rub against the drum, which can result in faster wear of the brake linings and / or overheating of the brake.

operation of the piston rod fork (6) must be mounted on the expander arm (1) so that when fully braked the angle of operation is approx. 90 °.

The control consists in measuring the extension length of each piston rod during braking at a standstill. If the piston rod stroke exceeds the maximum value (45mm), the system should be adjusted.

When removing the cylinder fork (6), remember or mark the original position of the cylinder fork pin (7). The mounting position depends on the type of braking system and the size of the tires used in the manure spreader, it is selected by the Manufacturer and cannot be changed.

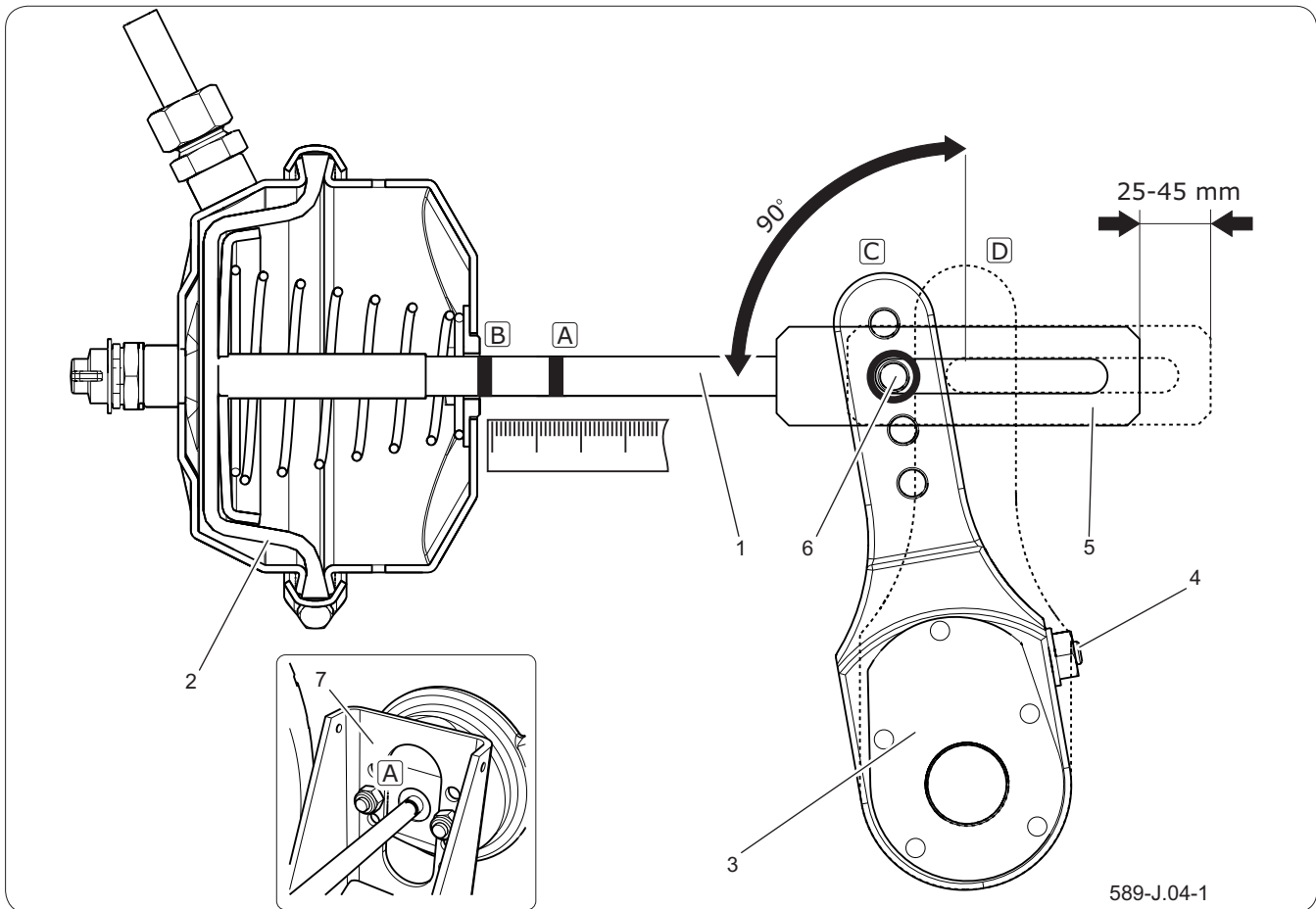

Figure 6.21 Pneumatic brake adjustment

(1) piston, (2) cylinder membrane, (3) expander arm, (4) adjustment screw, (5) cylinder fork, (6) fork pin, (7) cylinder support,

(A) the tag on the piston in the brake release position, (b) the tag on the pistons in the full stop position, (c) the position of the arm in the brake release position, (D) arm in full stop position

The scope of activities



CAUTION

The mounting positions of the brake cylinder in the bracket holes and the cylinder pin in the expander arm are determined by the Manufacturer and cannot be changed.

Whenever removing the pin or actuator, it is recommended to mark the location of the original attachment.

- Connect the trailer to tractor.
- Turn off the tractor engine and remove the keys from the ignition.
- Immobilize tractor with parking brake.
- Make sure the trailer is not braked.
- Secure trailer against rolling with wheel chocks.
- On the piston rod (1) - figure (6.6), (6.7) of the cylinder mark with a line (A) the position of the maximum retraction of the piston rod with the trailer brake off.
- Press the brake pedal on the tractor, mark with a line (B) the position of maximum extension of

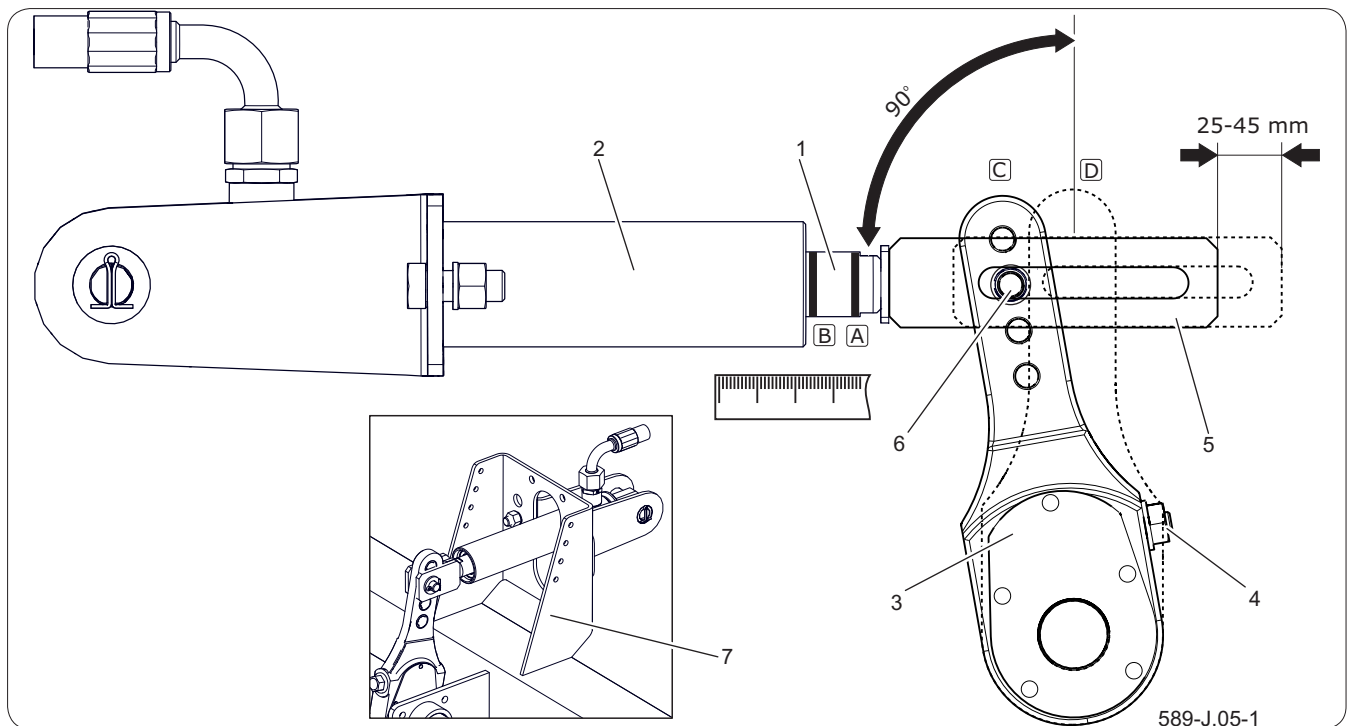

Figure 6.22 Hydraulic brake adjustment

(1) piston rod, (2) cylinder piston, (2) expander arm,
 (4) adjustment screw, (5) cylinder fork, (6) fork pin,
 (7) cylinder support,

(A) the tag on the piston in the brake release position, (b) the tag on the pistons in the full stop position,
 (c) the position of the arm in the brake release position,
 (D) arm in full stop position

the piston rod.

- Measure the distance between the lines (A) and (B). If the piston rod stroke is not within the correct working range (25-45mm), adjust the expander arm.
- Remove the the actuator fork pin (6).
- Remember or mark the original position of the cylinder fork (6) in the expander arm bore (3).
- Check the that the cylinder piston moves freely and within the full nominal range.
- Check that the air vents of the actuator are not clogged with dirt and that there is no water or ice inside (pneumatic actuator). Check the correct mounting of the actuator.
- Clean the cylinder, defrost if necessary and drain water through the unblocked ventilation holes (pneumatic cylinder). If damage is found, replace

the actuator with a new one. When mounting the actuator, keep its original position relative to the bracket (7).

- Turn the adjusting screw (4) so that the marked hole of the expander arm coincides with the hole of the cylinder fork
- During adjustment, the diaphragm (2) must rest on the rear wall of the cylinder - figure (6.6) (pneumatic cylinder).
- Install the piston rod fork pin and washers and secure the pin with cotter pins.
- Turn the adjusting screw (4) clockwise to make one or two clicks in the expander arm adjustment mechanism.
- Repeat the adjustment on the second cylinder on the same axis.
- Apply the brake.
- Wipe previous markings and measure piston rod stroke again.
- If the piston rod stroke is not within the correct operating range, repeat the adjustment.

Functional check

- After completing the adjustment, carry out a test drive.
- Perform several brakes. Stop the trailer and check the temperature of the brake drums.
- If any drum is too hot, correct the brake adjustment and perform the test drive again.

SER.3.8-026.01.EN

6.25 ELECTRICAL SYSTEM SERVICE AND WARNING ELEMENTS



CAUTION

Driving with defective lighting installations is prohibited. Damaged lamps should be replaced immediately before driving off. Lost or damaged reflectors should be replaced with new ones.

Before travelling, make sure that all lamps and reflectors are clean.

ADVICE

The light source in the lamps are LEDs and in case of damage are only replaced as a complete lamp without the possibility of repair or regeneration.

Work related to the repair, replacement or regeneration of electrical installation components should be entrusted to specialized workshops that have appropriate technologies and qualifications to perform this type of work.

The user's duties include only technical inspection of the electrical installation and reflectors.

The scope of activities

- Connect the the trailer to the tractor with a suitable connection lead.
- Make sure the connection cable is OK. Check the connection sockets on the tractor and on the trailer.
- Check the completeness, technical condition and correct functioning of the trailer lighting.
 - ***Check the wiring harness for damage (rubbed insulation, wire break, etc.). Check the completeness of lamps and all reflectors.***
- Check the correct installation of the triangular plate holder for slow moving vehicles.
- Before travelling on a public road, make sure that the tractor has a reflective warning triangle.

SER.3.8-027.01.EN

6.26 LUBRICATION

ADVICE

Lubrication frequency (Table Trailer lubrication schedule):

D - working day (8 hours of trailer),

M - month

- Lubrication of the trailer perform with manual or foot lubricators filled with the recommended lubricant. Before starting work, remove the old grease and other pollution. After finishing work, wipe off excess grease.
- Parts that should be lubricated using machine oil should be wiped with a dry and clean cloth. Apply the oil with a brush or oiler. Wipe off excess oil.
- The replacement of grease in wheel hub bearings should be entrusted to specialized service points equipped with the appropriate tools. Dismantle the entire hub, remove the bearings and individual sealing rings. After thorough cleaning and inspection, install lubricated components. If necessary, replace bearings and seals.
- Empty containers of grease or oil be disposed of in accordance with the lubricant manufacturer's instructions.

Table 6.7. Lubricants

Item	Symbol	Description
1	A	General purpose machine grease (lithium, calcium),
2	B	Solid grease for heavily loaded components with the addition of MoS ₂ or graphite
3	C	anticorrosive spray
4	D	regular machine oil, silicone spray grease

Table 6.8. Trailer lubrication schedule

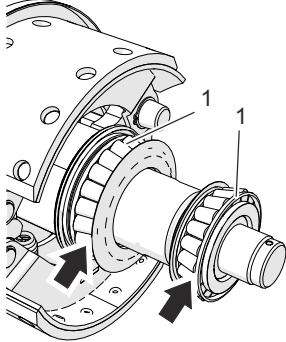
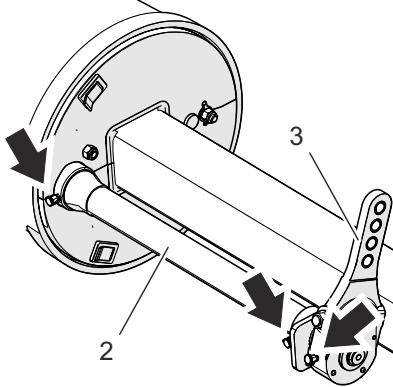
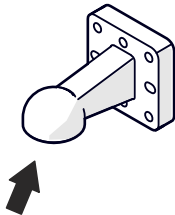
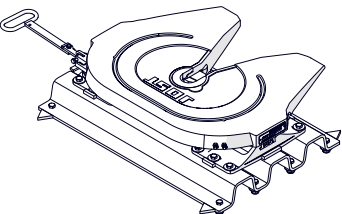
Item	Name	Number of	Type of grease	Frequency	
1	Hub bearing (2 pieces in each hub)	8	A	24M	
2	Expander shaft bushing	8	A	3M	
3	Expander arm	4	A	3M	
4	Drawbar eye	1	B	14D	 663-I.07-1
5	Fifth wheel coupling ⁽¹⁾				 663-I.09-1

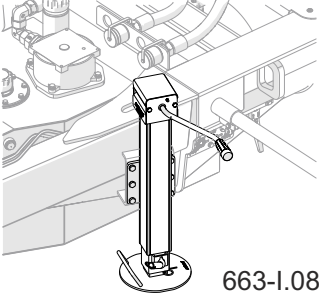
Item	Name	Number of	Type of grease	Frequency	
6	Support leg	1	A	3M	 <p>663-I.08-1</p>
<p>(1) - lubricate according to the fifth wheel coupling manufacturer's manual</p>					

SER.3.J-001.01.EN

6.27 CONSUMABLES

6.27.1 Hydraulic oil

ADVICE

In the hydraulic system of the trailer, L-HL 32 PN-91/ L-96067/ 04 oil was used.

It is absolutely necessary to observe that the oil in the trailer's hydraulic system and the semi-trailer's hydraulic system is of the same type. If different types of oil are used, make sure that both hydraulic means can be mixed together. The use of different types of oil may cause damage to the trailer or semi-trailer. The installation of new machine is filled with L-HL32 hydraulic oil.

If you need to change the hydraulic oil for another, read the oil manufacturer's instructions carefully. If he recommends flushing the system with an appropriate preparation, follow these recommendations. It ensured that the chemicals used for this purpose do not act aggressively on the materials of the hydraulic system. During normal operation of the trailer, it is not necessary to change the hydraulic oil, however, if necessary, this operation should be entrusted to specialist service centres.

Due to its composition, the oil used is not classified as a dangerous substance, however, long-term action on the skin or eyes may cause irritation. In the event of contact of oil with skin wash the area of contact with water and soap. Do not use organic solvents (petrol, kerosene). Dirty clothing should be removed

Table 6.9. Characteristics of the L-HL 32 oil

Item	Name	Unit	
1	Viscosity classification according to ISO 3448VG	-	32
2	Kinematic viscosity at 400C	mm ² /s	28.8 – 35.2
3	Quality classification according to ISO 6743/99	-	HL
4	Quality classification according to DIN 51502	-	HL
5	Flash-point	C	230



DANGER

Do not use water to extinguish a fire of oil!

to prevent oil from getting on your skin. If the oil gets into your eyes, flush them with plenty of water and in case of irritation contact your doctor.

Hydraulic oil under normal conditions is not harmful to the respiratory tract. There is only a risk when the oil is sprayed strongly (oil mist) or in the event of a fire where poisonous compounds may be released. In the event of fire, the oil must be extinguished with carbon dioxide, foam or extinguishing steam

6.27.2 Lubricants

ADVICE

Lubrication frequency (Table Trailer lubrication schedule).

For heavily loaded parts, it is recommended to use lithium grease with the addition of molybdenum disulphide (MOS2) or graphite. For less loaded components, it is recommended to use general-purpose machine greases that contain anti-corrosive additives and are highly resistant to water washout. Similar properties should be characteristic of aerosol preparations (silicone lubricants, anti-corrosive lubricants). Before using lubricants, read the information leaflet for the selected product. Particularly important are safety rules and how to handle a given lubricant and how to dispose of waste (used containers, contaminated rags, etc.). The information leaflet (product card) store together with the grease.

6.27.3 List of consumables for the machine

Table 6.10. List of consumables for the machine

Place of application - name	Quantity	Number / type
Oil tank - suction filter	1 pc	MSZ302DCXAB7
Oil tank - hydraulic filter	1 pc	SIF/30G/180I/10 (41002462)
Hydraulic system - hydraulic oil ⁽¹⁾	~150 L	L-HL 32 PN-91/L-96067/04

(1) - Oil tank capacity 155L

SER.3.I-010.01.EN

6.28 WHEEL INSTALLATION AND REMOVAL



DANGER

Danger of crushing. Be especially careful. Make sure that the hydraulic lift has the appropriate load capacity and is in good technical condition.

If necessary, call the service personnel.

It is forbidden to support the trailer with fragile elements (bricks, hollow bricks, concrete blocks).

After lifting the machine, secure it by placing stable and durable supports under the frame of appropriate load capacity.

Lifting of the trailer may only be performed when it is placed on a level and stable hard surface, e.g. concrete or asphalt surfaces. Lifting of the machine on slopes or unstable ground is prohibited.

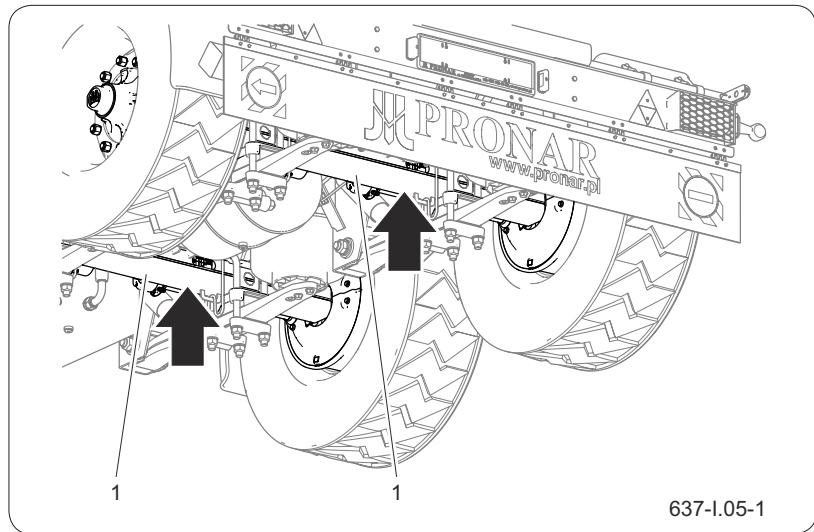

Figure 6.23 The place where the jack should be placed
(1) wheel axle beam

Removing of the wheel

- Secure the trailer against accidental or unauthorized activation.
- Secure the trailer against rolling away.

Place the chocks under the wheel on the opposite side.

- Loosen the wheel nuts according to the sequence given in the figure "The sequence of loosening and tightening of the nuts".
- Lower the jack and raise the trailer.

The jack should be placed under the axle beam near the spring. The place of support is shown in the figure "The place where the jack should be placed". The jack must be suited to the trailer's carb weight.

- Unscrew the nuts and remove the wheel.

Wheel attachment

- Clean the seating surface of the hub and rims.
- The contact area can be sprayed with a small amount of grease, the so-called dry lubricant (e.g. Teflon).
- Check the air pressure in the mounted wheel, if necessary, pump up the wheel.
- Clean wheel axle pins and nuts from dirt.

Do not lubricate the thread of the nut and stud.

ADVICE

The jack is not a part of the machine.

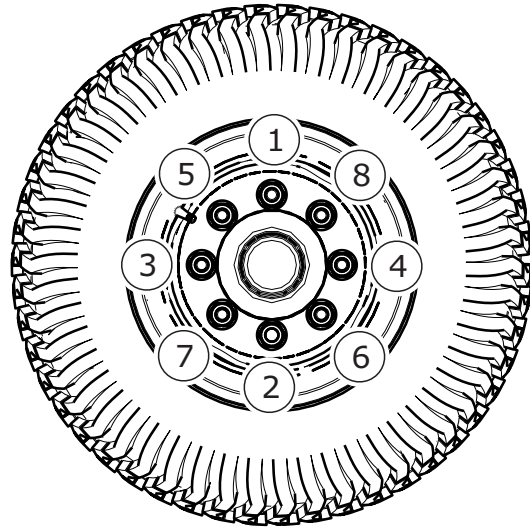

D.6-1

Figure 6.24 The order of the nuts unscrewing and tightening

- Check the condition of pins and nuts, replace if necessary.
- Put the wheel on the hub.
- Tighten the nuts so that the rim adheres perfectly to the hub.
- Remove the supports and lower the trailer.
- Tighten the nuts in accordance with the recommended torque and sequence.

SER.3.I-014.01.EN

6.29 TIRES

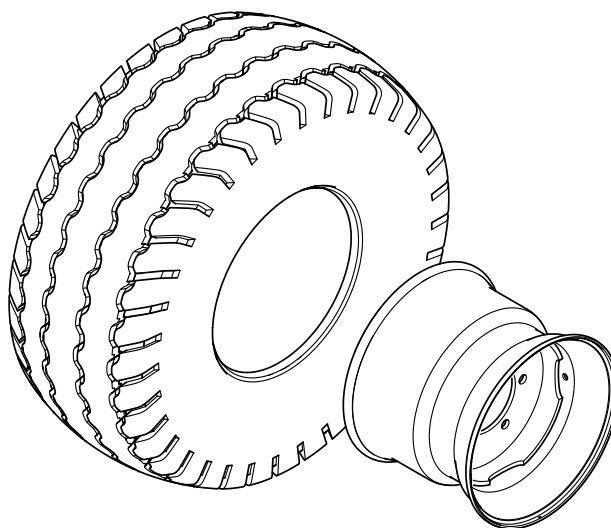

Table 6.11. Completion of tires

Item	Tire size	Rim	Pressure	Index of load	Index of speed
1	385/65 R22.5	11.75x22.5 (225.1175.106P)	800 kPa	min.160	min.E
2	425/65 R22.5	13x22.5 (225.13.104)	825 kPa	min.160	min.D
3	560/45 R22.5	16x22.5H2 (225.16.263)	400 kPa	min.152	min.D

SER.3.I-011.01.EN

6.30 FAULTS AND METHODS TO REMOVE THEM

Table 6.12. Faults and methods to remove them

Fault	Cause	Removal method
Trouble with starting.	Braking system conduits not connected.	Connect the brake lines (applies to pneumatic systems).
	Parking brake applied.	Release the parking brake.
	Damaged pneumatic system connection conduits.	Replace.
	Connections leak	Tighten, replace washers or sealing kits, replace wires.
	Defective control valve or brake force regulator.	Check valve, repair or replace.
Noise in the wheel axle hub.	Excessive clearance in the bearings.	Check the clearance and adjust if necessary
	Defective bearings.	Replace bearings
	Damaged hub components.	Replace.
Low efficiency of the braking system.	System pressure too low.	Check the pressure on the manometer in the tractor, wait until the compressor fills the tank to the required pressure. Damaged air compressor in the tractor. Repair or replace. Damaged brake valve on the tractor. Repair or replace. Installation leak. Check systems for leaks.
Excessive heating of wheel axle hub.	Incorrectly adjusted main or parking brake.	Adjust the position of the expander arms.
	Worn brake linings.	Replace the brake shoes
Incorrect hydraulic system operation.	Incorrect hydraulic oil viscosity.	Check the oil level and replace if necessary.

Incorrect hydraulic system operation.	Insufficient trailer hydraulic pump performance, trailer hydraulic pump defective.	Check the hydraulic pump.
	Damaged hydraulic lines	Check and make sure that the hydraulic conduits are tight, not kinked and properly tightened. Replace or tighten if necessary.
Damaged articulated telescopic shaft.	Too big angular deviation during operation.	Use a wide-angle shaft or disconnect the PTO when turning.
	Shaft too short or too long.	Change the PTO shaft to a different one. Align the shaft according to the directions in the operator's manual provided by the shaft's manufacturer.
Impossible tipping of the trailer.	Hydraulic system conduits not connected or connected incorrectly.	Check the connection and connect the wires in accordance with the operating instructions.
	The electric installation for controlling the solenoid valves is not connected.	Check the connection and connect the wires in accordance with the operating instructions.
	Defective remote control.	Carry out a repair with the service help.
	Damaged hydraulic quick couplers.	Replace.
	Insufficient amount of hydraulic oil in the hydraulic system.	Check the oil level in the reservoir and top up if necessary.
Lack of lighting.	Electrical installation not connected.	Connect the installation.
	Damaged electrical system of the machine (e.g. broken wiring).	Replace or repair with the service help.

SER.3.I-012.01.EN

