



PRONAR Sp. z o.o.

17-210 NAREW, UL. MICKIEWICZA 101A, WOJ. PODLASKIE

tel.:	+48 085 681 63 29	+48 085 681 64 29
	+48 085 681 63 81	+48 085 681 63 82
fax:	+48 085 681 63 83	+48 085 682 71 10

www.pronar.pl

OPERATOR'S MANUAL

AGRICULTURAL TRAILER

PRONAR T679

TRANSLATION OF THE ORIGINAL COPY OF THE MANUAL

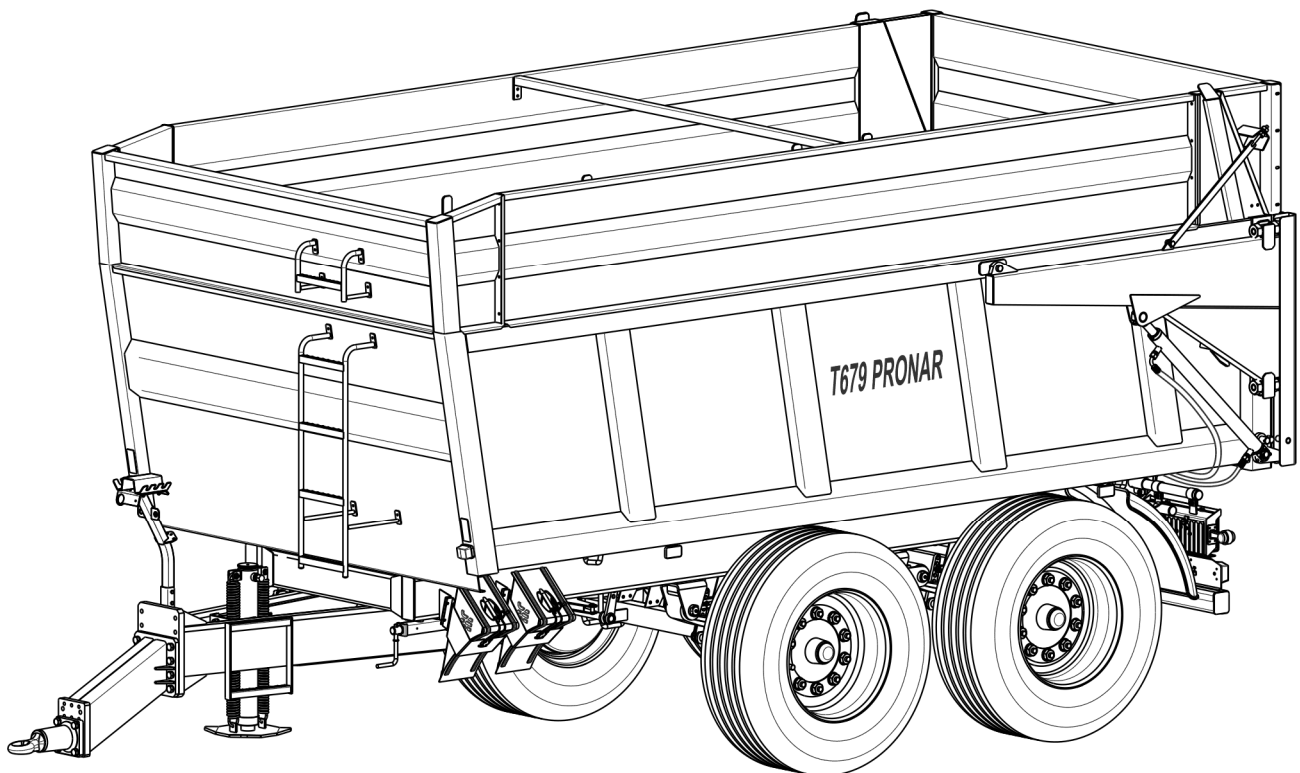

ISSUE 3A-03-2012

PUBLICATION NO 64N-00000000-UM



Thank you for purchasing our trailer. In the interests of your safety and care for the reliability and durability of the machine, we ask that you familiarise yourself with the content of this manual.

Remember!!!

Before using the trailer for the first time, check if the wheels are properly tightened!!! Regularly check the technical condition of the machine in accordance with the attached schedule.

INTRODUCTION

Information contained herein is current at date of publication. As a result of improvements, some numerical values and illustrations contained in this publication may not correspond to the factual specification of the machine supplied to the user. The manufacturer reserves the right to introduce design changes in machines produced that facilitate operation and improve the quality of their work, without making minor amendments to this Operator's Manual.

This Operator's Manual is an integral part of the machine's documentation. Before using the machine, the user must carefully read this Operator's Manual and observe all recommendations. This guarantees safe operation and ensures malfunction free work of the machine. The machine is designed to meet obligatory standards, documents and legal regulations currently in force.

The manual describes the basic safety rules and operation of agricultural trailer Pronar T679. If the information contained in the Operator's Manual needs clarification then the user should refer for assistance to the sale point where the machine was purchased or to the Manufacturer.

MANUFACTURER'S ADDRESS:

*PRONAR Sp. z o.o.
ul. Mickiewicza 101A
17-210 Narew*

CONTACT TELEPHONES

<i>+48 085 681 63 29</i>	<i>+48 085 681 64 29</i>
<i>+48 085 681 63 81</i>	<i>+48 085 681 63 82</i>

SYMBOLS APPEARING IN THIS OPERATOR'S MANUAL

Information, descriptions of danger and precautions and also recommendations and prohibitions associated with user safety instructions are marked:



and also preceded by the word "**DANGER**". Failure to observe the instructions may endanger the machine operator's or other person's health or life.

Particularly important information and instructions, the observance of which is essential, are distinguished in the text by the sign:



and also preceded by the word "**ATTENTION**". Failure to observe the instructions may lead to damage to the machine as a result of improper operation, adjustment or use.

In order to focus the user's attention on the need to perform maintenance, the relevant section of the Operator's Manual is marked with the pictogram:



Additional tips and advice for machine operation are marked:



and also preceded by the word „**TIP**”.

DIRECTIONS USED IN THIS OPERATOR'S MANUAL

Left side – side to the left hand of the operator facing in the direction of machine's forward travel.

Right side – side to the right hand of the operator facing in the direction of machine's forward travel.

REQUIRED SERVICE ACTIONS

Service actions described in the manual are marked: ➡

Result of service/adjustment actions or comments concerning the performance of actions are marked: ⇨



PRONAR Sp. z o.o.

ul. Mickiewicza 101 A
17-210 Narew, Polska

tel./fax (+48 85) 681 63 29, 681 63 81, 681 63 82,
681 63 84, 681 64 29

fax (+48 85) 681 63 83

<http://www.pronar.pl>

e-mail: pronar@pronar.pl

EC DECLARATION OF CONFORMITY OF THE MACHINERY

PRONAR Sp. z o.o. declares with full responsibility, that the machine:

Description and identification of the machinery	
Generic denomination and function:	AGRICULTURAL TRAILER
Type:	T679
Model:	-----
Serial number:	
Commercial name:	AGRICULTURAL TRAILER PRONAR T679

to which this declaration relates, fulfills all the relevant provisions of the Directive **2006/42/EC** of The European Parliament and of The Council of 17 May 2006 on machinery, and amending Directive 95/16/EC (Official Journal of the EU, L 157/24 of 09.06.2006).

The person authorized to compile the technical file is the Head of Research and Development Department at PRONAR Sp. z o.o., 17-210 Narew, ul. Mickiewicza 101A, Poland.

This declaration relates exclusively to the machinery in the state in which it was placed on the market, and excludes components which are added and/or operations carried out subsequently by the final user.

Narew, the 2014 -08- 28

Place and date

Z-CIA DYREKTORA
d/s technicznych
członk zarządu
Roman Dymochiuk

*Full name of the empowered person
position, signature*

CONTENTS

1 BASIC INFORMATION	1.1
1.1 IDENTIFICATION	1.2
1.1.1 TRAILER IDENTIFICATION	1.2
1.1.2 AXLE IDENTIFICATION	1.3
1.1.3 LIST OF SERIAL NUMBERS	1.4
1.2 INTENDED USE	1.5
1.3 EQUIPMENT	1.8
1.4 TERMS & CONDITIONS OF WARRANTY	1.10
1.5 TRANSPORT	1.11
1.5.1 TRANSPORT ON VEHICLE	1.12
1.5.2 INDEPENDENT TRANSPORT BY THE USER	1.14
1.6 ENVIRONMENTAL HAZARDS	1.14
1.7 WITHDRAWAL FROM USE	1.15
2 SAFETY ADVICE	2.1
2.1 BASIC SAFETY RULES	2.2
2.1.1 USE OF TRAILER	2.2
2.1.2 HITCHING AND UNHITCHING FROM TRACTOR	2.63
2.1.3 HITCHING AND UNHITCHING THE SECOND TRAILER	2.96
2.1.4 HYDRAULIC SYSTEM AND PNEUMATIC SYSTEM	2.121
2.1.5 LOADING AND UNLOADING	2.174
2.1.6 TRANSPORTING THE MACHINE	2.243
2.1.7 TYRES	2.301
2.1.8 MAINTENANCE	2.336
2.2 RESIDUAL RISK	2.469
2.3 INFORMATION AND WARNING DECALS	2.506

3 DESIGN AND OPERATION	3.1
3.1 TECHNICAL SPECIFICATION	3.2
3.2 TRAILER CONSTRUCTION	3.3
3.2.1 CHASSIS	3.3
3.2.2 LOAD BOX	3.5
3.2.3 MAIN BRAKE	3.7
3.2.4 HYDRAULIC TIPPING SYSTEM	3.12
3.2.5 SUPPORT HYDRAULIC SYSTEM	3.14
3.2.6 TAILGATE HYDRAULIC SYSTEM	3.17
3.2.7 PARKING BRAKE	3.18
3.2.8 LIGHTING SYSTEM	3.19
4 CORRECT USE	4.1
4.1 PREPARING FOR WORK BEFORE THE FIRST USE	4.2
4.1.1 CHECKING THE TRAILER AFTER DELIVERY	4.2
4.1.2 PREPARING THE TRAILER FOR THE FIRST HITCHING TO TRACTOR	4.3
4.2 HITCHING AND UNHITCHING THE TRAILER FROM TRACTOR	4.4
4.3 HITCHING AND UNHITCHING THE SECOND TRAILER	4.8
4.4 LOADING AND SECURING LOAD	4.10
4.4.1 GENERAL INFORMATION ABOUT LOADING	4.10
4.5 TRANSPORTING LOAD	4.17
4.6 UNLOADING	4.19
4.7 PROPER USE AND MAINTENANCE OF TYRES	4.21
5 MAINTENANCE	5.1
5.1 PRELIMINARY INFORMATION	5.2
5.2 MAINTENANCE OF BRAKES AND AXLES	5.2
5.2.1 PRELIMINARY INFORMATION	5.2

5.2.2	INITIAL INSPECTION OF AXLE BRAKES	5.3
5.2.3	CHECKING BRAKE SHOE LININGS FOR WEAR	5.3
5.2.4	CHECKING WHEEL AXLE BEARINGS FOR SLACKNESS	5.5
5.2.5	ADJUSTMENT OF PLAY OF WHEEL AXLE BEARINGS	5.7
5.2.6	MOUNTING AND DISMOUNTING WHEEL, INSPECTION OF WHEEL NUT TIGHTENING	5.8
5.2.7	CHECKING AIR PRESSURE IN TYRES, EVALUATING TECHNICAL CONDITION OF TYRES AND STEEL WHEELS	5.11
5.2.8	ADJUSTMENT OF MECHANICAL BRAKES	5.12
5.2.9	REPLACEMENT OF PARKING BRAKE CABLE AND ADJUSTMENT OF CABLE TENSION.	5.14
5.3	PNEUMATIC SYSTEM MAINTENANCE	5.16
5.3.1	PRELIMINARY INFORMATION	5.16
5.3.2	CHECKING AIR TIGHTNESS AND VISUAL INSPECTION OF PNEUMATIC SYSTEM	5.17
5.3.3	CLEANING THE AIR FILTERS	5.19
5.3.4	DRAINING WATER FROM AIR TANK	5.20
5.3.5	CLEANING THE DRAIN VALVE	5.21
5.3.6	CLEANING AND MAINTAINING PNEUMATIC CONDUIT CONNECTIONS AND PNEUMATIC SOCKETS	5.22
5.3.7	REPLACEMENT OF PNEUMATIC CONDUIT	5.22
5.4	HYDRAULIC SYSTEM MAINTENANCE	5.23
5.4.1	PRELIMINARY INFORMATION	5.23
5.4.2	CHECKING HYDRAULIC SYSTEM TIGHTNESS	5.24
5.4.3	CHECKING TECHNICAL CONDITION OF HYDRAULIC COUPLERS AND SOCKETS.	5.25
5.4.4	REPLACEMENT OF HYDRAULIC CONDUITS	5.25
5.5	MAINTENANCE OF ELECTRICAL SYSTEM AND WARNING ELEMENTS	5.25
5.5.1	PRELIMINARY INFORMATION	5.25
5.5.2	REPLACEMENT OF BULBS	5.27

5.6	TRAILER LUBRICATION	5.28
5.7	CONSUMABLES	5.32
5.7.1	HYDRAULIC OIL	5.32
5.7.2	LUBRICANTS	5.33
5.8	CLEANING THE TRAILER	5.34
5.9	STORAGE	5.35
5.10	TIGHTENING TORQUE FOR NUT AND BOLT CONNECTIONS	5.36
5.11	INSTALLATION AND DISASSEMBLY OF THE FRAME AND TARPAULIN COVER	5.37
5.12	ADJUSTMENT OF DRAWBAR POSITION	5.39
5.13	TROUBLESHOOTING	5.41

SECTION

1

BASIC INFORMATION

1.1 IDENTIFICATION

1.1.1 TRAILER IDENTIFICATION

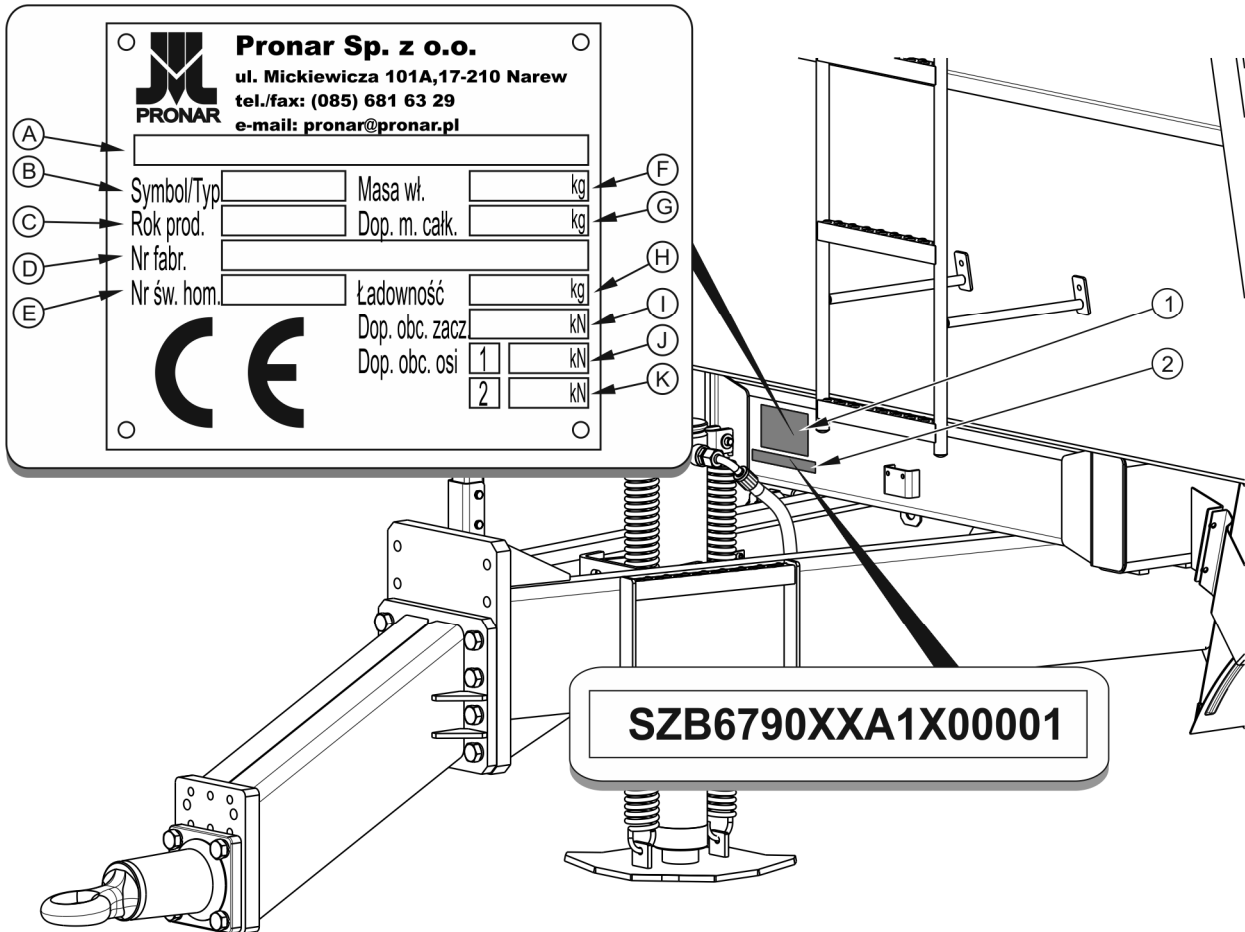

FIGURE 1.1 Location of the data plate and serial number

(1) data plate, (2) serial number

The trailer is marked with the data plate (1), and the factory number (2) located on a gold painted rectangle. The serial number and data plate are located on the front beam of the lower frame – figure (1.1).

When buying the trailer check that the serial numbers on the machine agree with the number written in the *WARRANTY BOOK*, in the sales documents and in the *OPERATOR'S MANUAL*. The meanings of the individual fields found on the data plate are presented in the table below:

TABLE 1.1 Markings on data plate

ITEM	MARKING
A	General description and purpose
B	Symbol / type of trailer
C	Trailer's year of manufacture
D	Seventeen digit vehicle identification number (VIN)
E	Official certificate number
F	Tare weight
G	Maximum gross weight
H	Carrying capacity
I	Permissible hitching system loading
J	Permissible front axle load
K	Permissible rear axle load

1.1.2 AXLE IDENTIFICATION

The serial number of the wheel axle and its type are stamped onto the data plate (2) secured to the wheel axle beam (1) – figure (1.2).

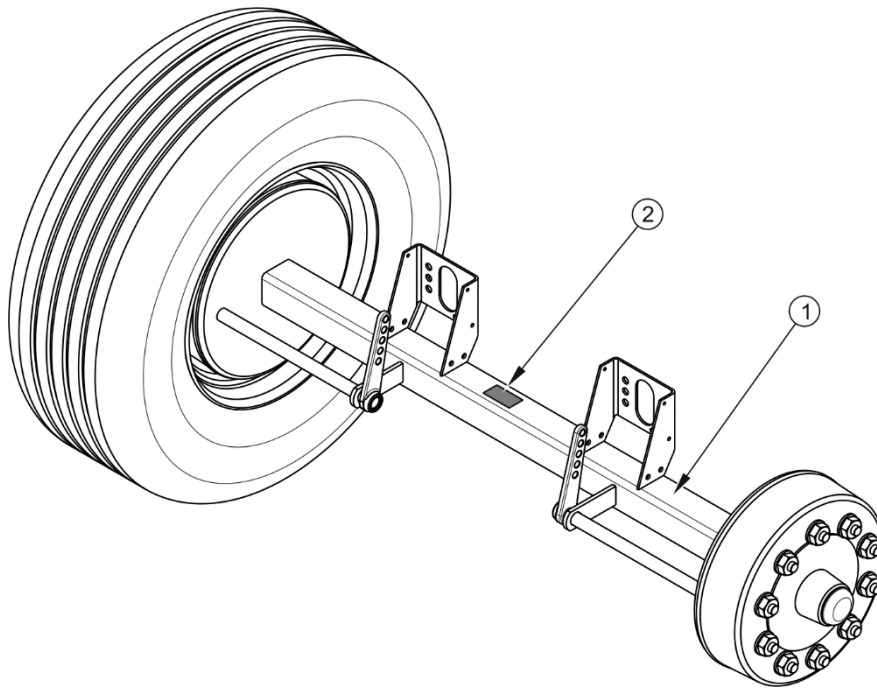



FIGURE 1.2 Location of the axle data plate

(1) axle, (2) data plate

1.1.3 LIST OF SERIAL NUMBERS

	<p>TIP</p> <p>In the event of ordering a replacement part or in the case of the appearance of problems it is often essential to give the factory numbers of parts or the VIN number of the trailer, therefore it is recommended that these numbers are inscribed in the spaces below.</p>
---	--

VIN

S	Z	B	6	7	9	0	X	X			X				
---	---	---	---	---	---	---	---	---	--	--	---	--	--	--	--

FRONT AXLE FACTORY NUMBER AND TYPE

REAR AXLE FACTORY NUMBER AND TYPE

1.2 INTENDED USE

The trailer is designed for transport of harvested crops and agricultural products as well as loose, bulk and long load materials at the farm and on public roads. It is acceptable to transport construction materials, mineral fertilizers and other loads, if fulfilling conditions indicated in section 4. Non-compliance with the recommendations for the carriage and loading of goods described by the Manufacturer and the road transport regulations in force in the country in which the trailer is used shall void the warranty and is regarded as use of the machine contrary to its intended purpose.

The trailer is not intended or designed for transporting people, animals or goods classified as dangerous materials.

ATTENTION

The trailer must not be used for purposes other than those for which it is intended. The user **MUST NOT**:



- transport people, animals, hazardous materials, chemically aggressive loads that will corrode the structural elements of the trailer (causing corrosion of steel, destruction of paint coat, dissolving plastic elements and destruction of rubber elements etc.),
- transport incorrectly secured load, which during travel may cause contamination of the road and natural environment,
- transport incorrectly secured load, which during travel may change position in load box,
- transport loads, whose centre of gravity may destabilise the trailer,
- transport loads, which have uneven load distribution and/or overload axles and suspension elements.

The trailer is designed according to current safety requirements and engineering standards. The brake system and the light and indicator system meet the requirements of road traffic regulations. The maximum speed of the trailer on public roads is 30 km/h (pursuant to Traffic Law Act of June 20th 1997, article 20). In the countries where the trailer is used, the limits stipulated by the road traffic legislation in force in a given country must be observed. The trailer speed must not, however, be greater than the maximum design speed of 40 km/h.

Using it as intended also involves all actions connected with the safe and proper operation and maintenance of the machine. Due to the above, the user is obliged to:

- carefully read the *OPERATOR'S MANUAL* of the trailer and the *WARRANTY BOOK* and conform with the recommendations contained in these documents,
- understand the trailer's operating principle and how to operate it safely and correctly,
- adhere to the established maintenance and adjustment plans,
- comply with general safety regulations while working,
- prevent accidents,
- comply with the road traffic regulations and transport regulations in force in a given country, in which the trailer is used,
- carefully read the Operator's Manual and comply with its recommendations,
- only hitch the trailer to an agricultural tractor which fulfils all the requirements made by the trailer's Manufacturer.

The trailer may only be used by persons, who:

- are familiar with the contents of this publication and with the contents of the agricultural tractor Operator's Manual,
- have been trained in trailer operation and work safety,
- have the required authorisation to drive carrying vehicles and are familiar with the road traffic regulations and transport regulations.

TABLE 1.2 Requirements for agricultural tractor

CONTENTS	UNIT	REQUIREMENTS
Brake system - sockets		
Single conduit pneumatic system	-	according to ISO 1728
Double conduit pneumatic system	-	according to ISO 1728
Hydraulic system	-	according to ISO 7421-1
Maximum system pressure		
Single conduit pneumatic system	bar / kPa	5.8 / 580
Double conduit pneumatic system	bar / kPa	8 / 800
Hydraulic system	bar / MPa	150 / 15
Hydraulic tipper system		
Hydraulic oil	-	L HL 32 Lotos ⁽¹⁾
Maximum system pressure	bar / MPa	200 / 20
Oil demand:	l	18
Electrical system		
Electrical system voltage	V	12
Connection socket	-	7-pole socket compliant with ISO 1724
Required tractor hitch		
Type	-	transport hitch
Minimum static vertical load capacity (S)	kg	1,950
Other requirements		
Minimum tractor power	kW / hp	61 / 82.2

⁽¹⁾ – use of other oil is permitted on condition that it may be mixed with the oil in the trailer. Detailed information can be found on the product information card.

In the event that the trailer shall be hitched to a second trailer it must fulfil the requirements stipulated in table (1.3).

TABLE 1.3 Requirements for second trailer

CONTENTS	UNIT	REQUIREMENTS
Maximum gross weight	kg	16,000
Brake system - connectors		
Single conduit pneumatic system	-	coupler compliant with ISO 1728
Double conduit pneumatic system	-	coupler compliant with ISO 1728
Hydraulic system	-	coupler compliant with ISO 7421-1
Maximum system pressure		
Single conduit pneumatic system	bar / kPa	5.8 / 580
Double conduit pneumatic system	bar / kPa	8 / 800
Hydraulic system	bar / MPa	150 / 15
Hydraulic tipper system		
Hydraulic oil	-	L HL 32 Lotos ⁽¹⁾
Minimum system pressure	bar / MPa	200 / 20
Electrical system		
Electrical system voltage	V	12
Connection socket	-	7-pole socket compliant with ISO 1724
Trailer's drawbar		
Type	-	swing (double axle trailer)
Drawbar eye diameter	mm	40

⁽¹⁾ – use of other oil is permitted on condition that it may be mixed with the oil in the trailer. Detailed information can be found on the product information card.

1.3 EQUIPMENT

Some standard equipment elements, which were listed in table (1.4), may not be present in the delivered trailer. This allows the possibility of ordering new machines with a different set of optional equipment, replacing standard equipment.

Information on tyres is provided at the end of this publication in ANNEX A.

TABLE 1.4 Trailer's equipment

EQUIPMENT	STANDARD	ADDITIONAL	OPTIONS
Operator`s Manual	•		
Warranty Book	•		
Connection lead for the electrical system	•		
Wheel chocks	•		
Hydraulic straight support	•		
Single conduit pneumatic system without rear connector	•		
Single conduit pneumatic system with rear connector			•
Double conduit pneumatic system without rear connectors			•
Double conduit pneumatic system with rear connectors			•
Double conduit pneumatic system with ALB, without rear connectors			•
Double conduit pneumatic system with ALB, with rear connectors			•
Complete set of wall extensions (580)	•		
Frame with tarpaulin cover		•	
Fenced platform		•	
Automatic rear hitch		•	
Rear hitch		•	
Rotating drawbar eye Ø50	•		
Ball drawbar eye K80			•
Fixed drawbar eye Ø40			•
Hydraulic brake system			•

EQUIPMENT	STANDARD	ADDITIONAL	OPTIONS
Double conduit pneumatic system with ALB			•
Complete set of wall extensions (580 mm) with mesh			•
Drawbar shear type support			•
Mechanical support			•
Telescopic support			•
Chute		•	
Slow-moving vehicle warning sign		•	
Reflective warning triangle		•	

1.4 TERMS & CONDITIONS OF WARRANTY

PRONAR Sp. z o.o., Narew guarantees the reliable operation of the machine when it is used according to its intended purpose as described in the *OPERATOR'S MANUAL*. The repair period is specified in the *WARRANTY BOOK*.

The warranty does not cover those parts and sub-assemblies of the machine which are subject to wear in normal usage conditions, regardless of the warranty period. Consumables include the following parts/sub-assemblies:

- drawbar hitching eye,
- pneumatic system connector filters,
- tyres,
- brake shoes,
- bulbs and LED lamps,
- seals,

- bearings.

The warranty service only applies to such cases as: mechanical damage which is not the user's fault, factory defects of parts, etc.

In the event of damage arising from:

- mechanical damage which is the user's fault, damage caused by road accidents,
- incorrect use, adjustment or maintenance, use of the trailer for purposes other than those for which it is intended,
- use of damaged machine,
- repairs carried out by unauthorised persons, repairs carried out improperly,
- making unauthorised alterations to machine design,

the user will lose the right to warranty service.



TIP

Demand that the seller carefully and precisely fills out the Warranty Book and guarantee repair coupons. A missing date of purchase or sale point stamp may make the user ineligible for any warranty repair or refund.

The user is obliged to report immediately on noticing any wear in the paint coating or traces of corrosion, and to have the faults rectified whether they are covered by the warranty or not. For detailed Terms & Conditions of Warranty, please refer to the *WARRANTY BOOK* attached to each newly purchased machine.

Modification of the trailer without the written consent of the Manufacturer is prohibited. In particular, do NOT weld, drill holes in, cut or heat the main structural elements of the machine, which have a direct impact on the machine operation safety.

1.5 TRANSPORT

The trailer is ready for sale completely assembled and does not require packing. Packing is only required for the machine's technical documentation and any extra equipment. The trailer is delivered to the user either transported on a vehicle or, after being attached to a tractor, independently (trailer towed with a tractor).

1.5.1 TRANSPORT ON VEHICLE

Loading and unloading of trailer from vehicle shall be conducted using loading ramp with the aid of an agricultural tractor. During work, adhere to the general principles of occupational health and safety (OHS) applicable to reloading work. Persons operating reloading equipment must have the qualifications required to operate these machines. The trailer must be properly connected with the tractor according to the requirements in this Operators Manual. The trailer braking system must be started and checked before driving off or onto ramp.

The trailer should be attached firmly to the platform of the vehicle using straps or chains fitted with a tightening mechanism. Securing elements should be attached to the transport catches designed for this purpose (1) – figure (1.3), or permanent structural elements of the trailer (longitudinal members, crossbars etc.) Transport lugs are welded to the load box elements (3), a pair on each side of the trailer, and marked with decals (8) - see table (2.1). Use certified and technically reliable securing measures. Worn straps, cracked securing catches, bent or corroded hooks as well as elements damaged in a different way may be unsuitable for use. Carefully read the information stated in the Operator's Manual for the given securing measure. Chocks, wooden blocks or other objects without sharp edges should be placed under the wheels of the trailer to prevent it from rolling. Trailer wheel blocks must be nailed to the low platform planks of the vehicle or secured in another manner preventing their movement. The number of securing elements (cables, straps, chains and stay etc.) and the force necessary for their tensioning depends on a number of things, including weight of the trailer, the construction of vehicle carrying trailer, speed of travel and other conditions. For this reason it is impossible to define the securing plan precisely. A correctly secured trailer does not change its position with regard to the transport vehicle. The securing elements must be selected according to the guidelines of the Manufacturer of these elements. In case of doubt apply a greater number of securing straps in order to immobilise the trailer. If necessary, sharp edges of trailer should be protected at the same time protecting the securing straps from breaking during transport.

ATTENTION

When being road transported on a motor vehicle the trailer must be mounted on the vehicle's platform in accordance with the transport safety requirements and the regulations.

Driver of the vehicle should be particularly careful during travel. This is due to the vehicle's centre of gravity shifting upwards when loaded with the machine.

Use only certified and technically reliable securing measures. Carefully read the information contained in the Operator's Manuals for the given securing measures.

During reloading work, particular care should be taken not to damage parts of the machine's equipment or the paint coating. The tare weight of the trailer in condition ready for travel is given in table (3.1).

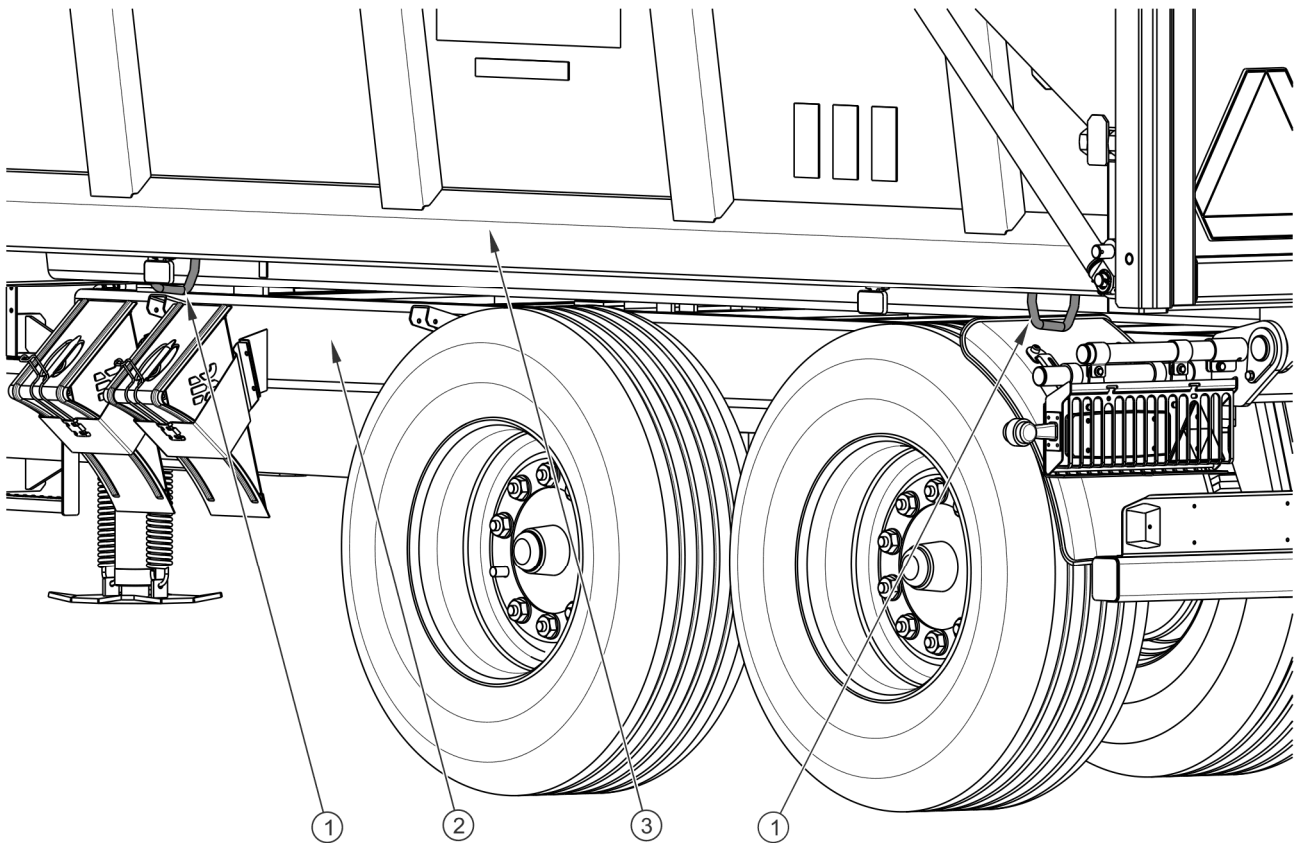

FIGURE 1.3 Positioning of transport lugs

(1) transport lug, (2) lower longitudinal frame, (3) load box

**DANGER**

Incorrect use of securing measures may cause an accident.

1.5.2 INDEPENDENT TRANSPORT BY THE USER

If a purchased trailer is transported by the user, the user must read the Operator's Manual of the trailer and adhere to the recommendations contained therein. Transport of the trailer by the user involves towing the trailer with own agricultural tractor to destination. During transport adjust travel speed to the prevailing road conditions, but do not exceed the maximum design speed.

**ATTENTION**

Before transporting independently, the tractor driver must carefully read this Operator's Manual and observe its recommendations.

1.6 ENVIRONMENTAL HAZARDS

A hydraulic oil leak constitutes a direct threat to the natural environment owing to its limited biodegradability. The negligible solubility of hydraulic oil in water does not cause extreme toxicity of organisms living in the aquatic environment. The formation of a film of oil on the water may be the direct cause of physical action on organism, perhaps causing change of oxygen values in the water because of lack of direct contact of air with the water. An oil leak into water reservoirs may however lead to a reduction of the oxygen content.

While carrying out maintenance and repair work, which involves the risk of an oil leak, this work should take place on an oil resistant floor or surface. In the event of oil leaking into the environment, first of all contain the source of the leak, and then collect the leaked oil using available means. Remaining oil should be collected using sorbents, or by mixing the oil with sand, sawdust or other absorbent materials. The oil pollution, once gathered up, should be kept in a sealed, marked, hydrocarbon resistant container. The container should be kept away from heat sources, flammable materials and food.

**DANGER**

Used hydraulic oil or gathered remains mixed with absorbent material should be stored in a precisely marked container. Do not use food packaging for this purpose.

Used oil or oil unsuitable for further use due to loss of its properties should be stored in its original packaging in the conditions described above. Waste oil should be taken to the appropriate facility dealing with the re-use of this type of waste. Waste code: 13 01 10. Detailed information concerning hydraulic oil may be found on the product's Material Safety Data Sheet.

**TIP**

The hydraulic system of the trailer is filled with L-HL32 Lotos hydraulic oil.

**ATTENTION**

Waste oil should only be taken to the appropriate facility dealing with the re-use of this type of waste. Do NOT throw or pour oil into sewerage or water tanks.

1.7 WITHDRAWAL FROM USE

In the event of decision by the user to withdraw the trailer from use, comply with the regulations in force in the given country concerning withdrawal from use and recycling of machines withdrawn from use. Before commencing dismantling, totally remove the oil from the hydraulic system and reduce air pressure completely in the pneumatic braking system (e.g. using air tank drain valve).

When spare parts are changed, worn out or damaged parts that cannot be reclaimed should be taken to a collection point for recyclable raw materials. Hydraulic oil should be taken to the appropriate facility dealing with the re-use of this type of waste.

**DANGER**

During dismantling, use the appropriate tools, equipment (overhead travelling crane, crane or hoist etc.) and use personal protection equipment, i.e. protective clothing, footwear, gloves and eye protection etc.

Avoid contact of skin with oil. Do not allow used hydraulic oil to spill.

SECTION

2

SAFETY ADVICE

2.1 BASIC SAFETY RULES

2.1.1 USE OF TRAILER

- Before using the machine, the user must carefully read this Operator's Manual and the *WARRANTY BOOK*. When operating the machine, the operator must comply with all recommendations contained in the Operator's Manual.
- The trailer may only be used and operated by persons qualified to drive agricultural tractors and agricultural machines and trained in the use of the machine.
- If the information contained in the Operator's Manual is difficult to understand, contact the seller who runs the authorised technical service on behalf of the Manufacturer, or contact the Manufacturer directly.
- Careless and incorrect use and operation of the trailer, and non-compliance with the recommendations given in this operator's manual is dangerous to your health.
- Be aware of the residual risk. Use caution when operating this machine and follow all relevant safety instructions.
- The machine must never be used by persons who are not authorised to drive agricultural tractors, including children and people under the influence of alcohol, drugs or other abusive substances.
- Non-compliance with the safety rules of this Operator's Manual can be dangerous to the health and life of the operator and others.
- The trailer must not be used for purposes other than those for which it is intended. Anyone who uses the trailer other than the way intended takes full responsibility for himself for any consequences of this potentially incorrect use. Use of the machine for purposes other than those for which it is intended by the Manufacturer may invalidate the guarantee.
- Assembly and disassembly of extension walls, the frame and tarpaulin cover, can only be carried out with the use of appropriate platforms, ladders or from a ramp. These devices must be in good condition to fully protect the persons working on

them against falling. The above procedure should be performed by at least two persons.

- In the final phase of folding the tarpaulin cover, at all times hold with one hand the top of the front frame or other permanent structural element. Non-compliance with this rule can put the user at risk of falling.

2.1.2 HITCHING AND UNHITCHING FROM TRACTOR

- Do NOT hitch the trailer to tractor if the tractor does not fulfil the requirements specified by the Manufacturer (minimum tractor power demand, wrong hitch, etc.) – see table (1.2) *REQUIREMENTS FOR AGRICULTURAL TRACTOR*. Before hitching the trailer make certain that oil in external hydraulic system of tractor may be mixed with the hydraulic oil of the trailer.
- Before hitching trailer to tractor check that tractor and trailer are in good technical condition.
- To hitch the trailer to a tractor, use exclusively the tractor hitch for single axle trailers. After completed hitching of the machines check that the hitch is properly secured. Carefully read the tractor Operator's Manual. If the tractor is equipped with an automatic hitch, make certain that the coupling operation is completed.
- Be especially careful when hitching the machine.
- When hitching, there must be nobody between the trailer and the tractor.
- Do NOT proceed with unhitching the trailer from the tractor when load box is raised.
- Hitching and unhitching the trailer may only take place when the machine is immobilised with the parking brake.

2.1.3 HITCHING AND UNHITCHING THE SECOND TRAILER

- Do NOT connect a second trailer, if it does not fulfil the requirements made by the Manufacturer (lack of required drawbar eye, exceeding permissible total weight etc.) – see table (1.3) *REQUIREMENTS FOR SECOND TRAILER*. Before hitching the machines make certain that the oil in both trailers may be mixed.
- Only double axle trailers may be hitched to the trailer.

- Before hitching the trailer check that both machines are in good technical condition.
- After completed hitching of the trailer check the safety of the hitch.
- Be especially careful when hitching the machine.
- When hitching, there must be nobody between the trailers. Person assisting in hitching the machines should stand outside the area of danger and be visible to the tractor driver at all times.
- Do NOT proceed with unhitching the second trailer from the tractor when load box is raised.

2.1.4 HYDRAULIC SYSTEM AND PNEUMATIC SYSTEM

- When operating, the hydraulic and pneumatic systems are under high pressure.
- Regularly check the technical condition of the connections and the hydraulic and pneumatic conduits. There must be no oil or air leaks.
- Cut-off valve in the hydraulic tipping system limits the tipping angle of the load box when tipped to the rear. The length of the control cable controlling this valve is factory adjusted by the Manufacturer and must not be changed when the trailer is used.
- In the event of malfunction of the hydraulic or pneumatic system, do not use the trailer until the malfunction is corrected.
- When connecting the hydraulic conduits to the tractor, make sure that the hydraulic system of the tractor and the hydraulic system of the trailer are not under pressure. If necessary, reduce residual pressure in the system.
- In the event of injuries being caused by pressurised hydraulic oil, contact a doctor immediately. Hydraulic oil may penetrate the skin and cause infections. In the event of contact of oil with eyes, rinse eyes with a large quantity of water and in the event of the occurrence of irritation consult a doctor. In the event of contact of oil with skin wash the area of contact with water and soap. Do NOT apply organic solvents (petrol, kerosene).
- Use the hydraulic oil recommended by the Manufacturer.

- After changing the hydraulic oil, the used oil should be properly disposed of. Used oil or oil which has lost its properties should be stored in original containers or replacement containers resistant to action of hydrocarbons. Replacement containers must be clearly marked and appropriately stored.
- Do not store hydraulic oil in packaging designed for storing food or foodstuffs.
- Rubber hydraulic conduits must be replaced every 4 years regardless of their technical condition.

2.1.5 LOADING AND UNLOADING

- Unloading the trailer is done only by tipping the load box to the rear.
- Unloading and loading of trailer may only take place when the machine is positioned on level and hard surface and connected to tractor. Tractor and trailer must be placed to drive forwards.
- Loading and unloading work should be carried out by persons experienced in this type of work.
- The load must be arranged in such a way that it does not threaten the stability of the trailer and does not hinder driving.
- Do NOT drive with the load box raised.
- Ensure that during unloading / loading or raising the load box nobody is near the trailer. Before tipping the load box ensure proper visibility and make certain that there are no bystanders near the trailer.
- The trailer is not intended for transporting people, animals or hazardous materials.
- Keep a safe distance from overhead electric power lines during unloading and when load box is raised.
- The arrangement of the load may not cause an overload on the axle of the trailer.
- Do NOT tip of the load box in windy conditions.
- When closing or opening the rear grain chute gate take particular care to avoid crushing fingers.

- Incorrect load distribution and overloading the machine may cause the trailer to tip over or cause damage to its components.
- Do NOT go or place hand between open tailgate and load box.
- If the load does not pour from the raised load box immediately cease unloading. The trailer may only be tipped again after removing the problem (sticking, wedging), which prevented the load from pouring.
- In winter, particular attention must be paid to loads which may freeze during transport. When tipping the load box with frozen load the trailer may become unstable and tip over.
- Do NOT raise the load box if there is any danger whatsoever that the box will tip over.
- Do NOT jerk the trailer forwards if load is bulky or reluctant to pour and does not unload.
- Do NOT climb on load box during loading and unloading.
- Lower the load box before proceeding to deal with a malfunction. If it is necessary to raise the load box then secure it against dropping with the aid of load box support. The load box may not be loaded, and the trailer must be connected to a tractor and secured with the aid of chocks and also immobilised with the parking brake.
- After completed unloading, ensure that the load box is empty.

2.1.6 TRANSPORTING THE MACHINE

- During travel on public roads comply with the road traffic regulations and transport regulations in force in a given country, in which the trailer is used.
- Do not exceed the permitted speed arising from road conditions and design limitations. Adjust travel speed to the prevailing road conditions, trailer load and road traffic regulations limits.
- The machine must NOT be left unsecured. Trailer disconnected from the tractor must be immobilized with parking brake and protected against rolling with chocks
- Before driving off make certain that the trailer is correctly hitched to the tractor.

- Chocks (1) should be placed only under one wheel (one in front of the wheel, the second behind the wheel - figure (2.1)).
- Do NOT move off or drive when load box is raised.
- Prior to moving off, check if the rear wall slide gate is secured. Make sure the tailgate is securely closed.
- Before using the trailer always check its technical condition, especially in terms of safety. In particular, check the technical condition of the hitch system, the axle system, the brake system, indicator lights and the connective elements of the hydraulic, pneumatic and electrical systems.

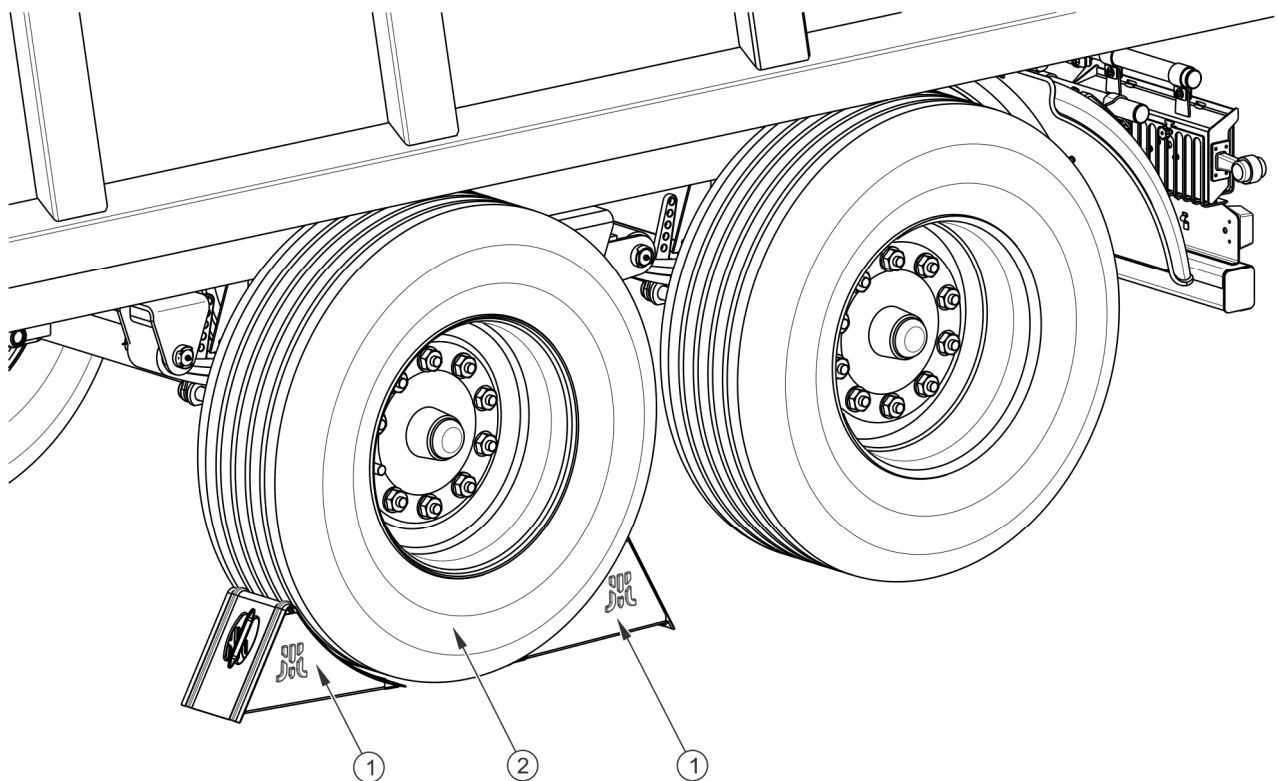

FIGURE 2.1 Method of placing chocks

(1) wheel chock, (2) axle wheel

- Before driving off check that the parking brake is released, the braking force regulator is positioned in the proper position (applies to pneumatic systems with a manual three position regulator).
- The trailer is designed to operate on slopes up to 8°. Driving trailer across ground with steeper slopes may cause the trailer to tip over as a result of loss of stability.

- While driving on public roads, the trailer and the tractor must be fitted with a certified or authorised reflective warning triangle.
- Periodically drain water from the air tanks in pneumatic system. During frosts, freezing water may cause damage to pneumatic system components.
- Reckless driving and excessive speed may cause accidents.
- A load protruding beyond the edge of the trailer should be marked according to the road traffic regulations. Do NOT transport loads forbidden by the Manufacturer.
- Do NOT exceed the trailer's maximum carrying capacity. Exceeding the carrying capacity may lead to damage to the machine, loss of stability while driving, scattering of the load and danger while driving. The brake system is adjusted to the gross weight of the trailer. Exceeding the weight limit causes drastic reduction of the main brake force.

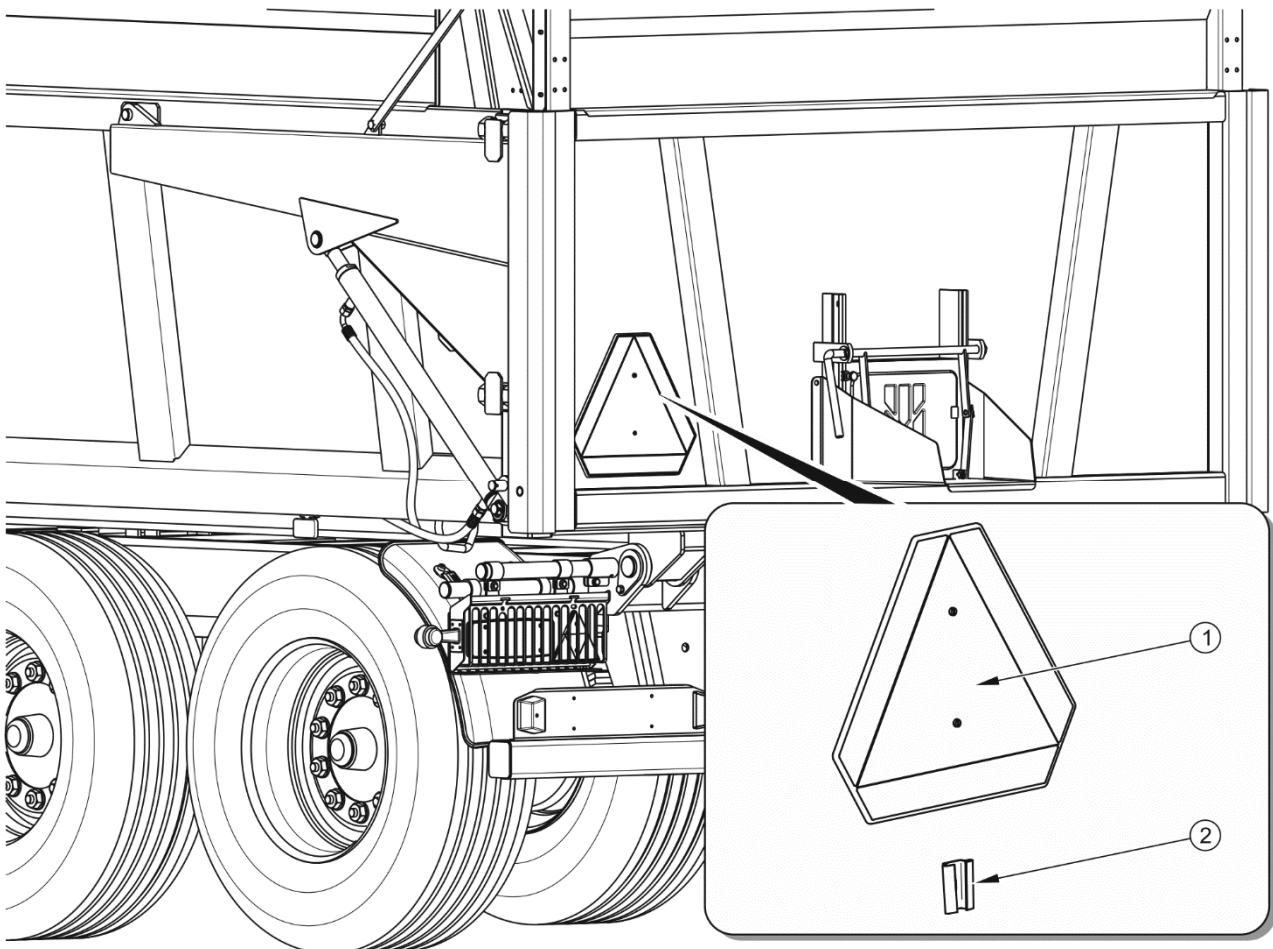

FIGURE 2.2 Mounting place for slow-moving vehicle warning sign

(1) slow-moving vehicle warning sign, (2) attachment point

- If the trailer is the last vehicle in the group, a slow-moving vehicle warning sign should be placed on the trailer's rear load box wall - figure (2.2). The warning sign (1) should be attached using the specifically prepared holder (2), riveted to the rear wall of the load box.
- Load must be uniformly distributed and it must not obstruct visibility or hinder driving. The load must be secured so that it cannot move or fall over.
- During reversing one should use the assistance of another person. During manoeuvring the assistant must stay at a safe distance from the danger zone and be visible all the time to the tractor driver.
- Do NOT attempt to enter the trailer load box while travelling.
- Do NOT park the trailer on a slope.

2.1.7 TYRES

- When working with tyres, the trailer should be immobilised with parking brake and secured against rolling by placing chocks under wheel. Wheels can be taken off the trailer axle only when the trailer is not loaded.
- Repair work on the wheels or tyres should be carried out by persons trained and entitled to do so. This work should be carried out using appropriate tools.
- Inspection of nut tightening should be carried out after first use of trailer, after first travel with load and then after 6 months use. In the event of intensive work, check the nut tightening at least every 100 km. The inspection should be repeated individually if a wheel has been removed from the wheel axle.
- Avoid potholes, sudden manoeuvres or high speeds when turning.
- Check the tyre pressure regularly. Air pressure in tyres should be also checked during the whole day of intensive work. Please note that higher temperatures could raise tyre pressure by as much as 1 bar. At high temperatures and pressure, reduce load or speed. Do not release air from warm tyres to adjust the pressure or the tyres will be underinflated when temperatures return to normal.
- Protect tyre valves using suitable caps to avoid soiling.

2.1.8 MAINTENANCE

- During the warranty period, any repairs may only be made by the Warranty Service authorised by the Manufacturer. After the expiry of the warranty period it is recommended that possible repairs to the trailer be performed by specialised workshops.
- In the event of any fault or damage, do not use the trailer until the fault has been fixed.
- During work use the proper, close-fitting protective clothing, gloves, protective goggles and appropriate tools.
- Any modification to the trailer frees the manufacturer from any responsibility for damage or detriment to health, which may arise as a result.
- The trailer can only be stood on when it is absolutely motionless and the tractor engine is switched off. Tractor and trailer should be immobilized with parking brake and chocks should be placed under the trailer wheels. Ensure that unauthorised persons do not have access to the tractor cab.
- Regularly check the condition of nut and bolt connections, in particular connections of drawbar eye with drawbar and wheel nuts.
- Regularly service machine according to schedule defined by Manufacturer.
- Before beginning work that require the load box to be raised, the load box must be emptied and secured by supports to prevent it from accidental falling. The trailer must at this time be hitched to the tractor and secured with chocks and parking brake.
- Before beginning repair work on hydraulic or pneumatic systems reduce oil or air pressure completely.
- Servicing and repair work should be carried out in line with the general principles of workplace health and safety. In the event of injury, the wound must be immediately cleaned and disinfected. In the event of more serious injuries, seek a doctor's advice.
- Repair, maintenance and cleaning work should be carried out with the tractor engine turned off and the ignition key removed. Tractor and trailer should be

immobilized with parking brake and chocks should be placed under the trailer wheels. Ensure that unauthorised persons do not have access to the tractor cab.

- During maintenance or repair work, the trailer may be unhitched from tractor, but it must be secured with chocks and parking brake. During this work the load box may not be raised.
- Should it be necessary to change individual parts, use only those parts indicated by the Manufacturer. Non-adherence to these requirements may put the user and other people's health and life at risk, and also damage the machine and invalidate the guarantee.
- Before welding or electrical work, the trailer should be disconnected from the power supply. The paint coating should be cleaned. Burning paint fumes are poisonous for people and animals. Welding work should be carried out in a well lit and well ventilated space.
- During welding work pay attention to flammable or fusible elements (parts of the pneumatic, electric and hydraulic systems, plastic parts). If there is a risk that they will catch fire or be damaged, they should be removed or covered with non-flammable material before commencing welding work. Before beginning work, prepare a CO₂ or foam extinguisher.
- In the event of work requiring the trailer to be raised, use properly certified hydraulic or mechanical lifts for this purpose. After lifting the machine, stable and durable supports must also be used. Work must not be carried out under a trailer, which has only been raised with a lift or jack.
- The trailer must not be supported using fragile elements (bricks or concrete blocks).
- After completing work associated with lubrication, remove excess oil or grease. The trailer should be kept clean and tidy.
- Exercise caution when climbing on top of the load box. Climbing on top of the load box is possible by use of ladders placed on the front wall, extension and draw bar and also folding steps inside the load box. Components not intended to aid access may not be used for this purpose. Before entering load box prevent trailer moving with parking brake and chocks.

- Do NOT make independent repairs of control valve, brake cylinders, tipping cylinder and braking force regulator. In the event of damage to these elements, repair should be entrusted to authorised service point or elements should be replaced with new ones.
- Do NOT make repairs to drawbar (straightening, pad welding or welding). A damaged drawbar must be replaced.
- Do NOT install additional appliances or fittings not according to the specifications defined by the Manufacturer.
- The trailer may only be towed when axles and wheels, lighting system and brakes are reliable.

2.2 RESIDUAL RISK

Pronar Sp. z o. o. in Narew has made every effort to eliminate the risk of accidents. There is, however, a certain residual risk, which could lead to an accident, and this is connected mainly with the actions described below:

- using the trailer for purposes other than those for which it is intended,
- being between the tractor and the trailer while the engine is running and when the machine is being attached or hitched to second trailer
- being on the machine during work,
- not maintaining safe distance during loading or unloading of trailer,
- operation of the trailer by persons under the influence of alcohol,
- making modifications to the machine without the consent of the Manufacturer,
- cleaning, maintenance and technical checks of the trailer,
- presence of persons or animals in areas invisible from the driver's position.

The residual risk can be kept to a minimum by following the recommendations below:



- operate the machine in prudent and unhurried manner,
- sensibly apply the remarks and recommendations contained in the Operator's Manual,



- maintain a safe distance from forbidden or dangerous places during unloading, loading and hitching trailer,
- carry out repair and maintenance work in line with operating safety rules,
- repair and maintenance work should be carried out by persons trained to do so,
- use close fitting protective clothing and appropriate tools,
- ensure unauthorised persons have no access to the machine, especially children,
- maintain a safe distance from prohibited or dangerous places
- a ban on being on the machine during travel, loading or unloading.



2.3 INFORMATION AND WARNING DECALS



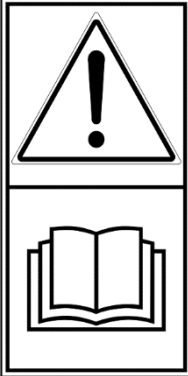

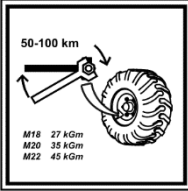
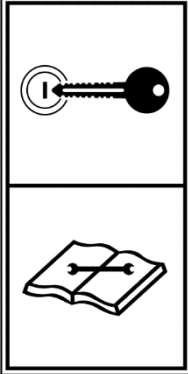

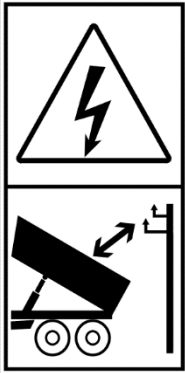
The trailer is labelled with the information and warning decals mentioned in table (2.1). The symbols are positioned as shown in figure (2.3). Throughout the time it is in use, the user of the machine is obliged to take care that notices and warning and information symbols located on the trailer are clear and legible. In the event of their destruction, they must be replaced with new ones. Safety decals are available from your PRONAR dealer or directly from PRONAR customer service. New assemblies, changed during repair, must be labelled once again with the appropriate safety signs. During trailer cleaning do not use solvents which may damage the coating of information label stickers and do not subject them to strong water jets.

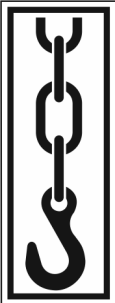
TABLE 2.1 Information and warning decals

NO.	DECAL	MEANING
1		Trailer version.
2		Trailer carrying capacity

NO.	DECAL	MEANING						
3		<p>Caution!</p> <p>Before starting work, carefully read the Operator's Manual.</p>						
4		<p>Grease the trailer according to the recommendations in the Operator's Manual</p>						
5	 <table border="1" data-bbox="528 1149 600 1189"> <tr> <td>M18</td> <td>27 kGm</td> </tr> <tr> <td>M20</td> <td>35 kGm</td> </tr> <tr> <td>M22</td> <td>45 kGm</td> </tr> </table>	M18	27 kGm	M20	35 kGm	M22	45 kGm	<p>Regularly check if the nuts and bolts fixing the wheels and other components are properly tightened.</p>
M18	27 kGm							
M20	35 kGm							
M22	45 kGm							
6		<p>Before beginning servicing or repairs, turn off tractor engine and remove key from ignition. Ensure that unauthorised persons do not have access to the tractor cab.</p>						

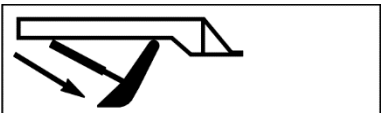
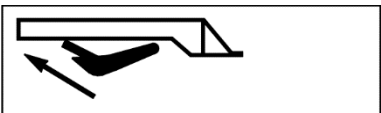
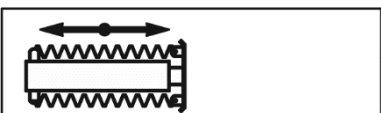
NO.	DECAL	MEANING
7		<p>Caution! Danger of electric shock.</p> <p>Keep a safe distance from overhead electric power lines during unloading.</p>
8		<p>Danger of crushing</p> <p>Do NOT perform any maintenance or repairs on the load box that is loaded, raised or not supported.</p>
9		<p>Danger of crushing</p> <p>Maintain a safe distance when opening and closing the tailgate.</p>
10		<p>Transport decal Anchorages for the transport</p>

NO.	DECAL	MEANING
11		Air pressure in the tyres. ⁽¹⁾
12		Permissible vehicle speed
13		Positions of control valve controlling work of hydraulic tipping system (1 or 2 trailers).
14		Conduit supplying hydraulic brake system.
15		Conduit supplying hydraulic tipping system.
16		Supply conduit of the shear type support's hydraulic system (lowering)
17		Supply conduit of the shear type support's hydraulic system (raising)
18		Supply conduit of the straight support's hydraulic system (withdrawing, extending)
19		Supply conduit of tailgate's hydraulic system (closing)

NO.	DECAL	MEANING
20		Supply conduit of tailgate's hydraulic system (opening)

⁽¹⁾ – pressure value should be adapted to tyres

Numbers in the item column correspond to labels in figure (2.3)

Decal (13) is placed near the hydraulic valve. Decals (14)-(20) are placed on the hydraulic conduits.

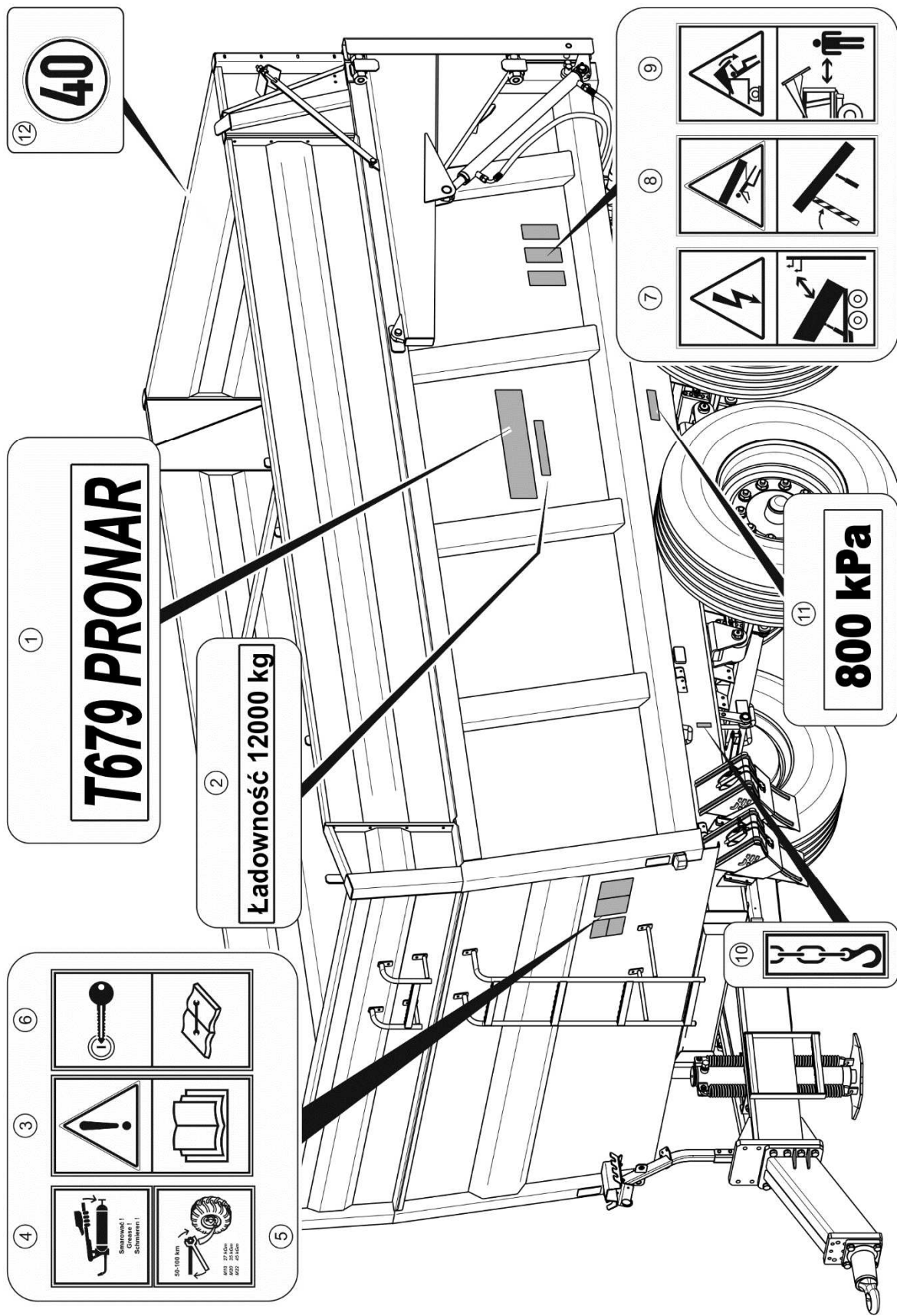

FIGURE 2.3 Locations of information and warning decals

SECTION

3

**DESIGN AND
OPERATION**

3.1 TECHNICAL SPECIFICATION

TABLE 3.1 Basic technical specification

CONTENTS	UNIT	T679
Trailer dimensions		
Total length	mm	6,259
Total width	mm	2,550
Total height	mm	2,866
Internal load box dimensions		
Length	mm	4,500
Width (front)	mm	2,200
Width (rear)	mm	2,250
Height	mm	1 000 + 580
Weight and carrying capacity		
Tare weight	kg	4,000
Maximum gross weight	kg	16,000
Maximum carrying capacity	kg	12,000
Other information		
Wheel track	mm	1,860
Maximum drawbar load	kg	1,950
Cargo capacity	m ³	15.8
Load surface	m ²	10
Lift of load surface	mm	1,240
Load box tipping angle - to the rear	(°)	50
Electrical system voltage	V	12
Hydraulic oil demand	l	18
Tractor power demand	kW / hp	61 / 83.2
Maximum design speed	km/h	40
Noise emission level	dB	below 70

3.2 TRAILER CONSTRUCTION

3.2.1 CHASSIS

The trailer chassis consists of the subassemblies indicated in figure (3.1). Lower frame (1) is a structure welded from steel sections. The main support elements of the frame are two longitudinal members connected with crossbars. In the middle section there are sockets (5) used for mounting the tipping hydraulic cylinder. Load box support (6) is mounted in front of the sockets of the tipping cylinder. At the rear of the frame there are lugs serving as pivot points during the tipping of the load box to the rear. Below there is a rear hitch connector and hydraulic and pneumatic system connectors to connect the second trailer. Under the hitch socket there is an under-run protective device (15). On both sides at the rear of the frame lights support beams (7) are bolted and plastic wheel mudguards (16).

Trailer suspension consists of two wheel axles (8), in a tandem arrangement, suspended on taper leaf springs (9) connected by rocker arm (10). Axles are secured to suspension springs using absorber plates and U bolts. Axles are made from bar terminated with pins, where wheel hubs are mounted on cone bearings. The wheels are single and equipped with shoe brakes activated by mechanical cam expanders.

In the front part of the chassis, parking stand (3) is mounted. Depending on the order placed, trailer can be equipped with one of the following supports:

- hydraulic straight support
- hydraulic shear type support,
- mechanical support,
- telescopic support.

Parking brake crank mechanism (14) is located on the left side of the lower frame. Drawbar (2) is bolted to the faceplate. Location of the drawbar can be adjusted depending on the tractor hitch (upper or lower) used to hitch the trailer. Rotating drawbar eye (11) with the eye of $\varnothing 50$ mm or ball drawbar eye K80 (13) is attached to the drawbar faceplate in the lower position. Fixed drawbar eye (12) with the eye diameter of $\varnothing 40$ mm is mounted to the trailer with the drawbar in the upper position.

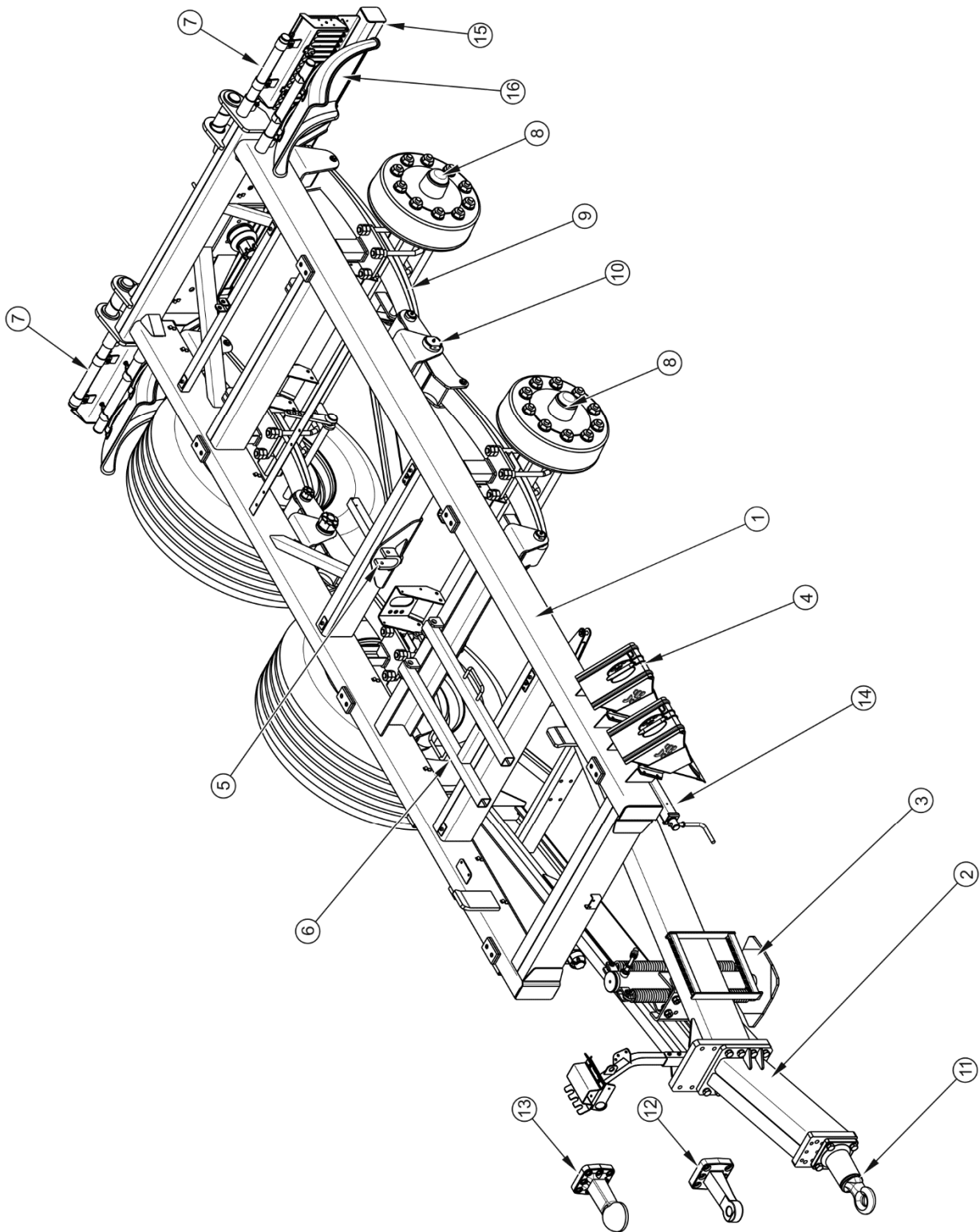

FIGURE 3.1 Trailer chassis

(1) lower frame, (2) shaft, (3) shear type support, (4) wheel chocks, (5) tipping cylinder suspension seat , (6) load box support, (7) lights support beam, (8) wheel axle , (9) shock absorber, (10) shock absorber rocker arm (11) - (13) drawbar eye, (14) parking brake mechanism, (15) under-run protective device, (16) mudguards

3.2.2 LOAD BOX

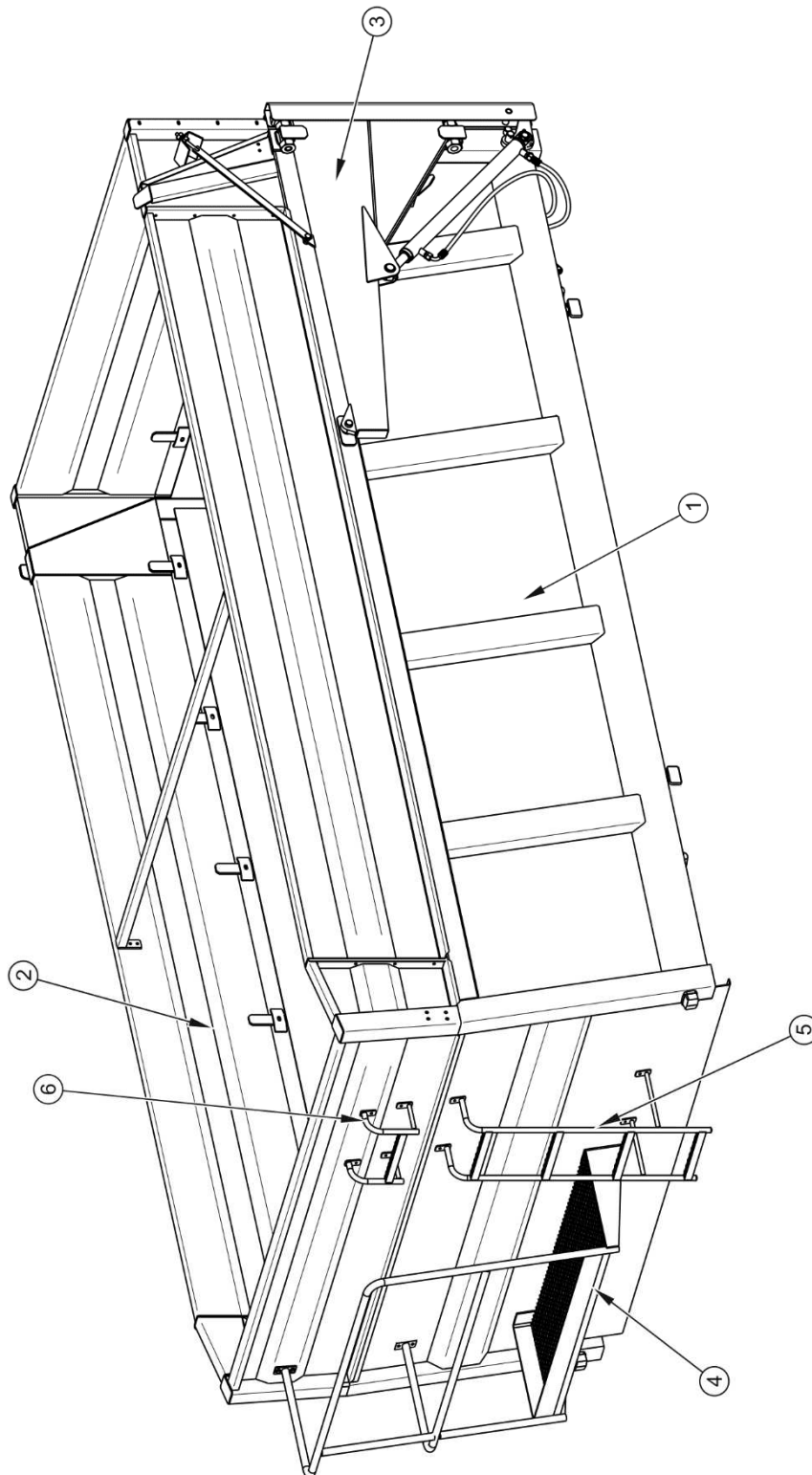

FIGURE 3.2 Load box

(1) load box, (2) wall extensions 580 mm, (3) wing of the tailgate, (4) fenced platform (option), (5) lower ladder, (6) wall extension ladder

The trailer load box (1) is a welded structure made from steel plate and shapes. – figure (3.2). To ensure smooth unloading it is in a shape of a cone. The load box is mounted on the lower frame (figure) (3.1)). The axis of rotation of the tilted load box is formed by the tipping pins located at the back of the lower frame. Load box is equipped with 580 mm wall extensions.

Access ladders (5) and (6) are secured to the front wall and extension. Folding steps are bolted on the inner side of the front wall to facilitate climbing into the load box. Fenced platform (4) and tarpaulin cover with a frame are available as additional equipment.

At the rear of the load box there is a wing-mounted tailgate (3). It is opened and closed by means of hydraulic cylinders.

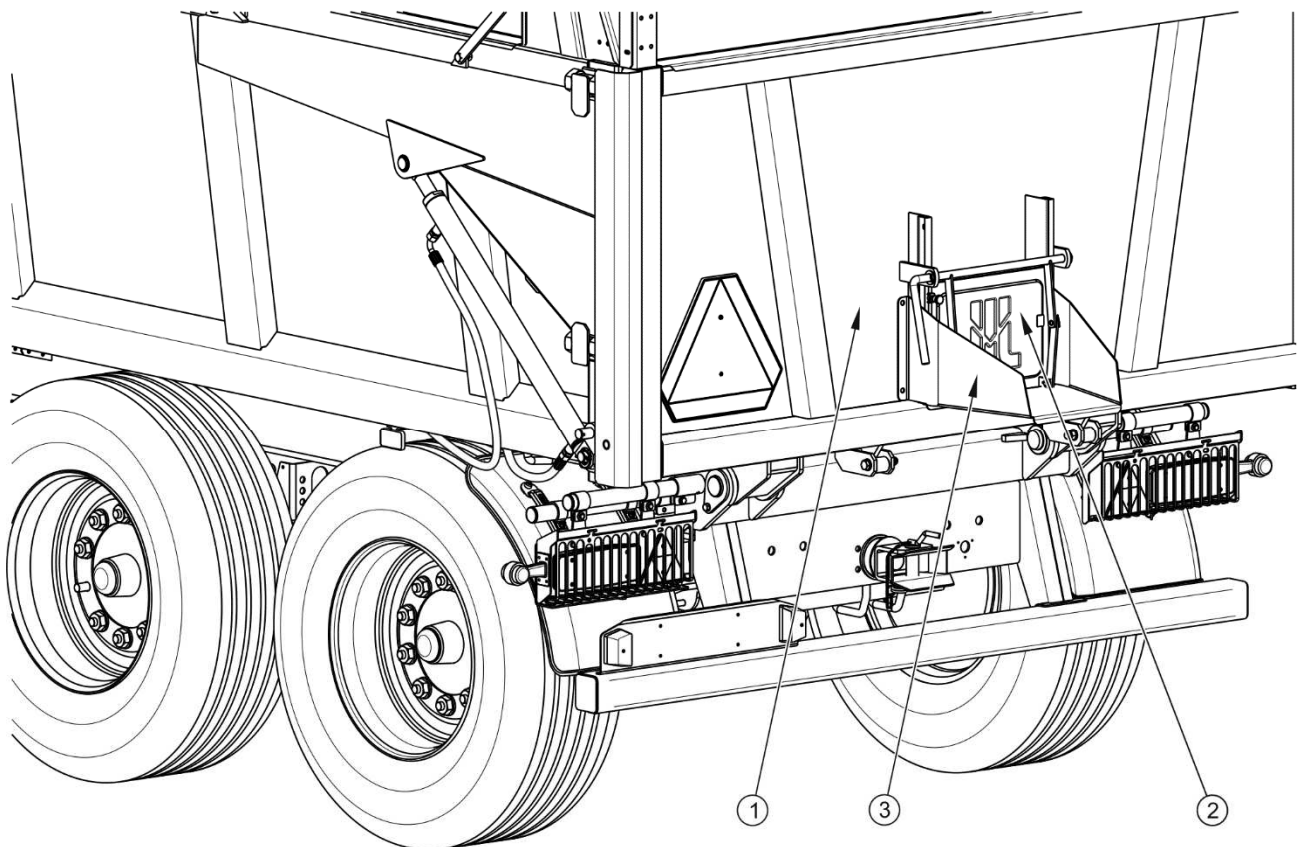

FIGURE 3.3 Rear wall slide gate

(1) tailgate, (2) slide gate, (3) chute

In order to enable more precise unloading of loose materials there is a slide gate (2) – figure (3.3) in the tailgate. A chute, secured under the lower edge of the chute opening slide gate, can be supplied as additional equipment of the trailer.

The trailer can be optionally equipped with 580mm wall extensions with mesh in the front extension.

3.2.3 MAIN BRAKE

The trailer is equipped with one of four types of main brake:

- single conduit pneumatic system with a three position regulator, figure (3.4),
- double conduit pneumatic brake system with a three position regulator, figure (3.5),
- double conduit pneumatic brake system with an automatic regulator, figure (3.6),
- hydraulic brake system, figure (3.7).

The main brake (pneumatic or hydraulic brake) is activated from the tractor driver's cab by depressing the brake pedal. The function of the control valve (2) - figure (3.4), (3.5) and (3.6), is to activate the trailer's brakes simultaneously with the tractor's brakes. Furthermore, in case of an inadvertent disconnection of the conduit between the trailer and the tractor, the control valve will automatically activate the trailer's brakes. The valve used in the system is equipped with a circuit causing the brakes to be applied when the trailer is disconnected from the tractor (compare figure(3.8)). When compressed air conduit is connected to the tractor, the device automatically applying the brakes changes its position to allow normal brake operation.

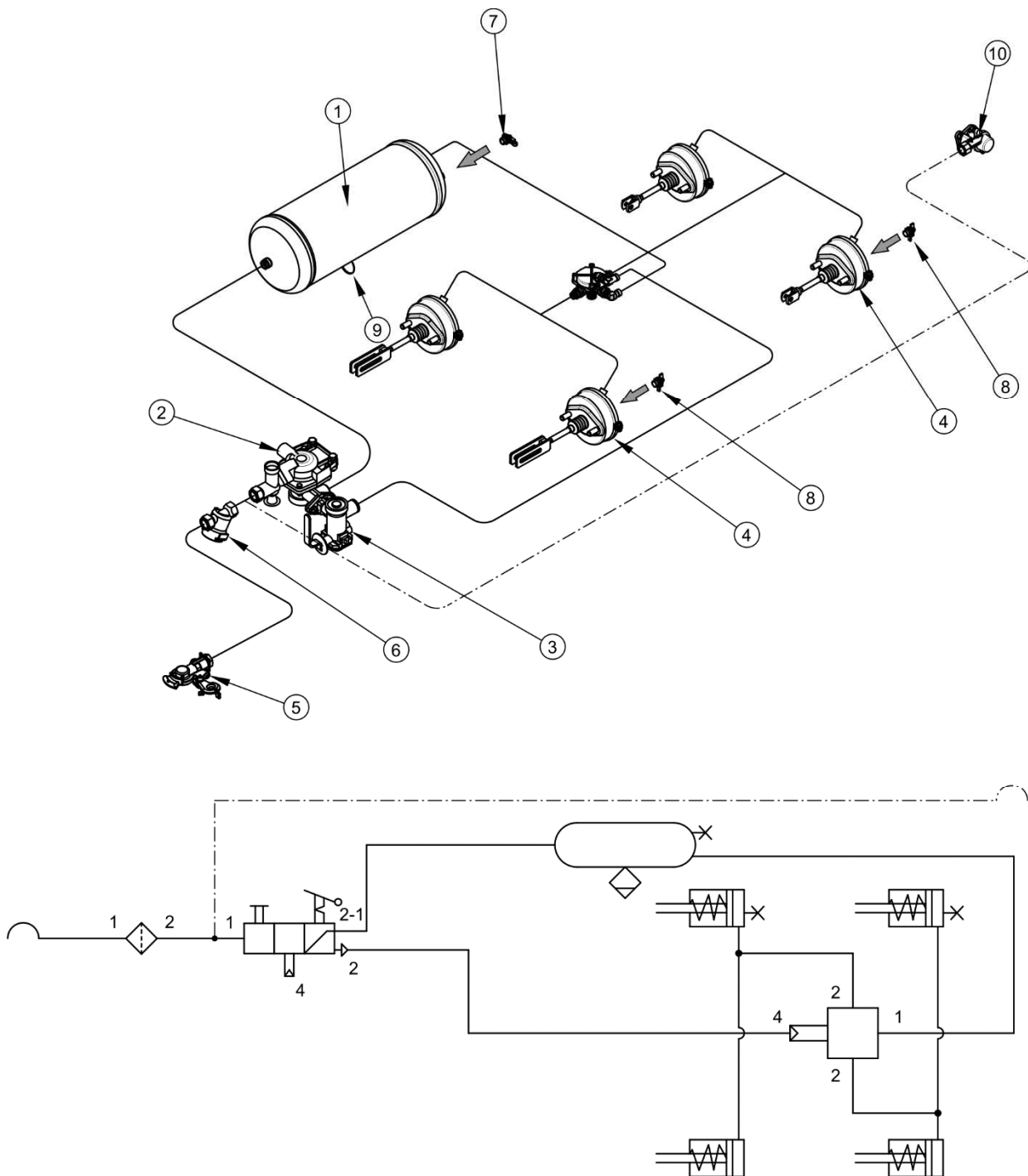

FIGURE 3.4 Design and diagram of the single conduit pneumatic braking system

(1) air tank, (2) control valve, (3) manual braking force regulator, (4) pneumatic cylinder, (5) conduit connector (black), (6) air filter, (7) air tank control connector, (8) pneumatic cylinder control connector, (9) drain valve, (10) socket (black) - option

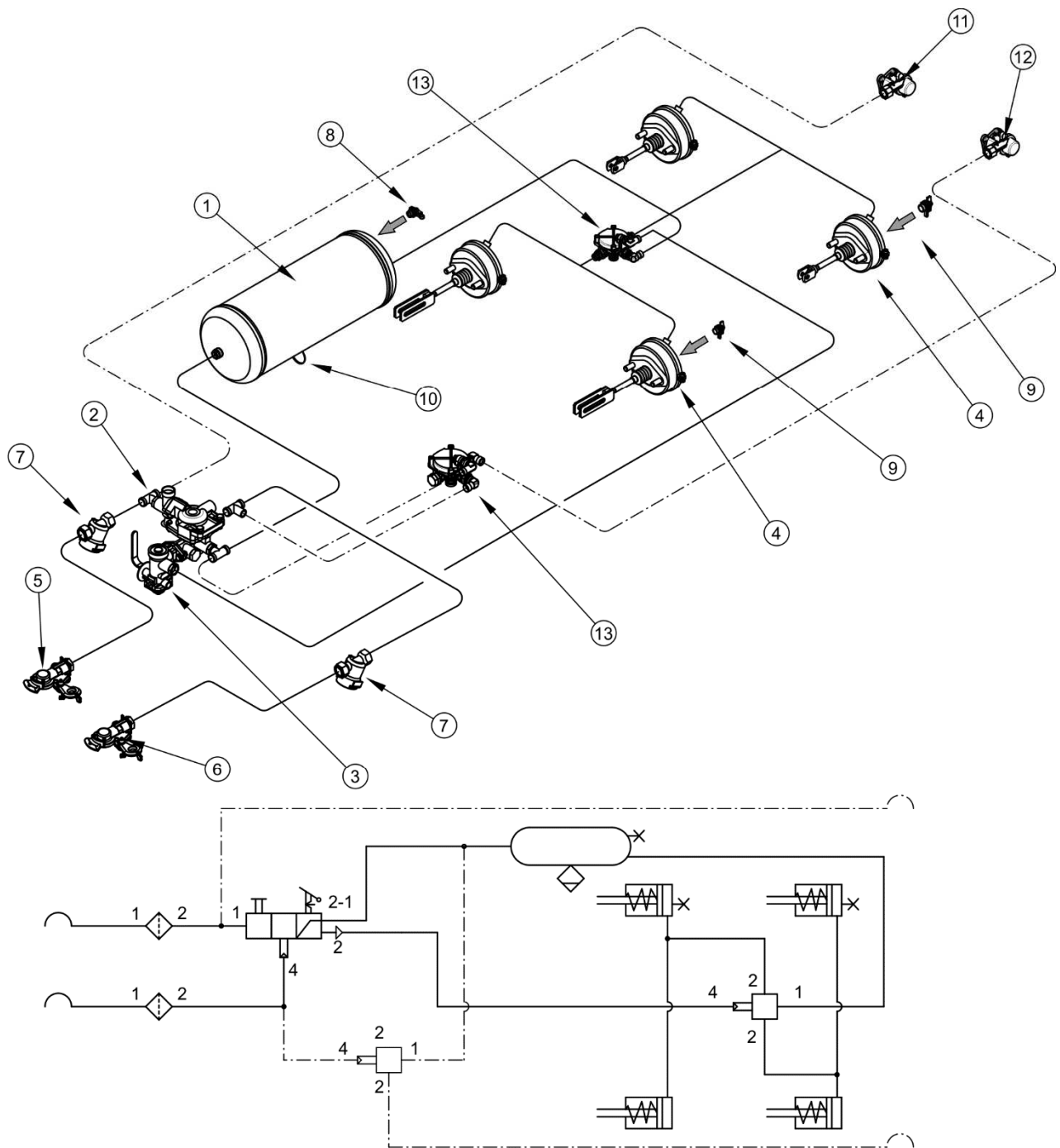

FIGURE 3.5 Design and diagram of the double conduit pneumatic *braking* system

(1) air tank, (2) control valve, (3) manual brake force regulator, (4) pneumatic cylinder, (5) conduit connector (red), (6) conduit connector (yellow), (7) air filter, (8) air tank control connector, (9) pneumatic cylinder control connector, (10) drain valve, (11) socket (red) - option, (12) socket (yellow) - option, (13) relay valve.

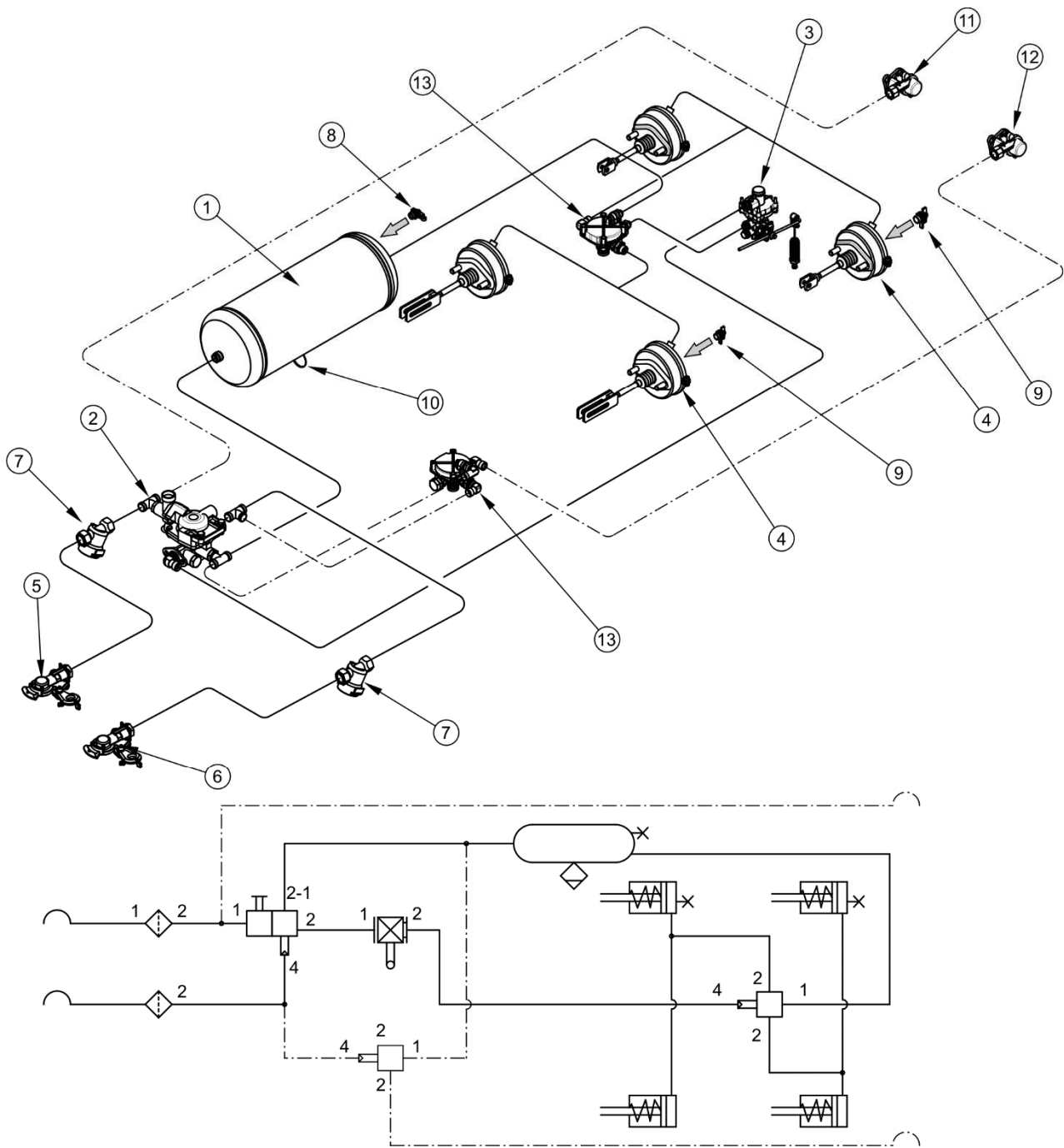

FIGURE 3.6 Design and diagram of the double conduit pneumatic braking system with an automatic regulator

(1) air tank, (2) control valve, (3) automatic brake force regulator, (4) pneumatic cylinder, (5) conduit connector (red), (6) conduit connector (yellow), (7) air filter, (8) air tank control connector, (9) pneumatic cylinder control connector, (10) drain valve, (11) socket (red) - option, (12) socket (yellow) - option, (13) relay valve

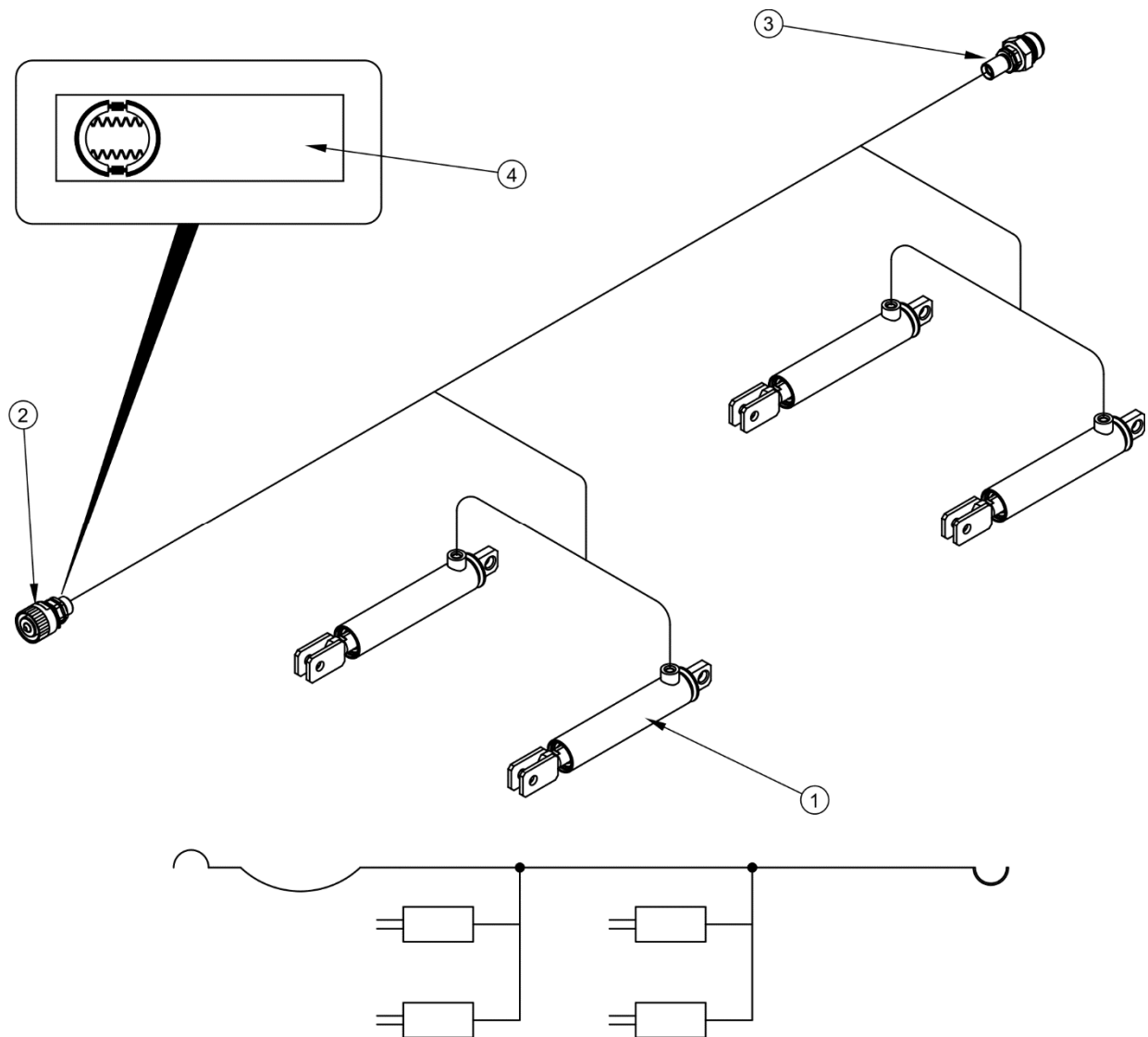

FIGURE 3.7 Design and diagram of hydraulic braking system

(1) hydraulic cylinder, (2) hydraulic quick coupler, (3) hydraulic socket, (4) information decal

Three-step braking force regulator (2) - figure (3.8) adjusts braking force depending on setting. Switching to a suitable working mode is done manually by the machine operator using the lever (4) prior to moving off. Three working positions are available: A - "no load", B - "half load" and C - "full load".

For systems with automatic regulator, braking force depends on trailer load.

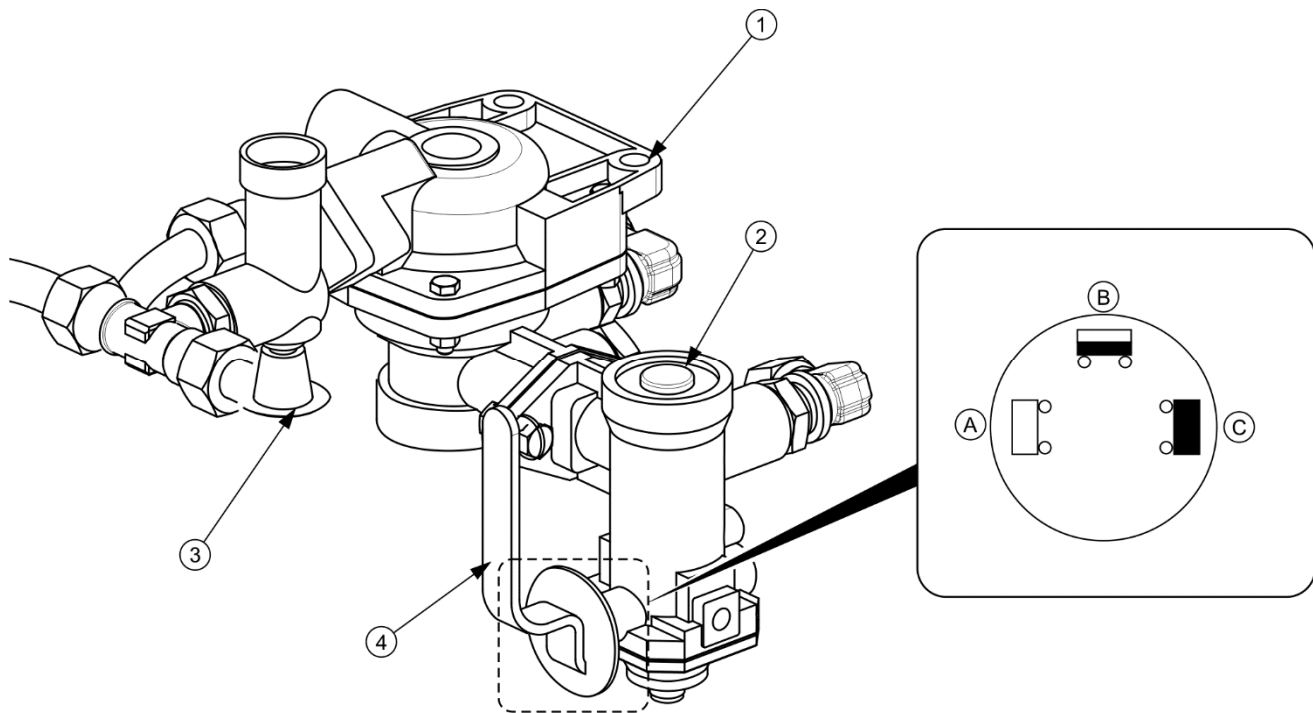

FIGURE 3.8 Control valve and braking force regulator

(1) control valve, (2) braking force regulator, (3) trailer parking brake release button, (4) work selection regulator lever, (A) position "NO LOAD", (B) position "HALF LOAD", (C) position "FULL LOAD"

3.2.4 HYDRAULIC TIPPING SYSTEM

Hydraulic tipping system ensures automatic unloading of trailer by tipping the load box to the rear. The hydraulic tipping system is supplied with oil from the tractor's hydraulic system. Hydraulic oil manifold of the tractor's external hydraulic system is used to control the load box tipping mechanism.

The trailer system consists of two independent circuits:

- circuit (A) - to supply the trailer's hydraulic cylinder,
- circuit (B) - to supply the second trailer's hydraulic cylinder (if two trailers are hitched to the tractor).

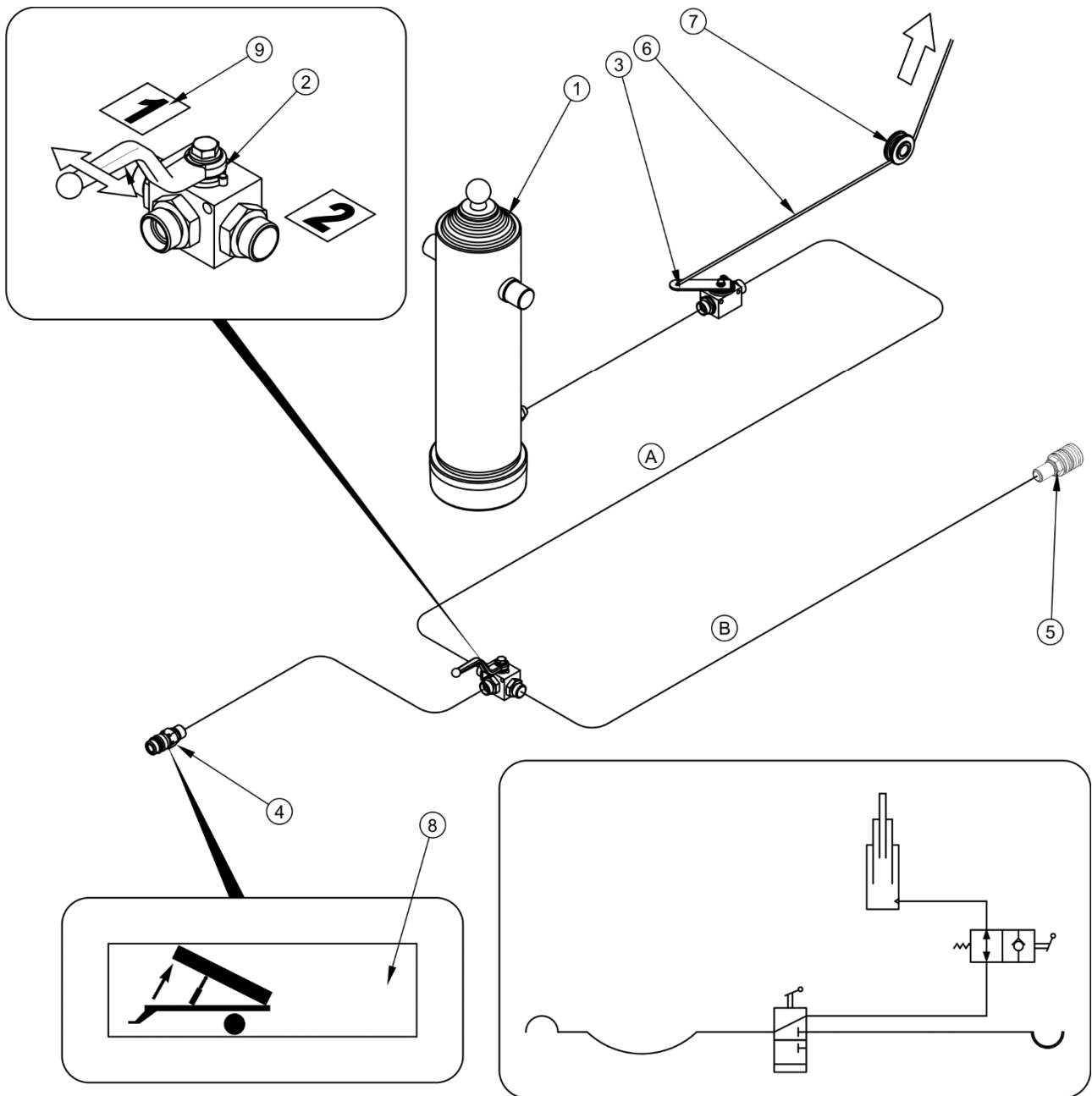

FIGURE 3.9 Hydraulic tipping system design and diagram

(1) telescopic cylinder, (2) three-way valve, (3) cut-off valve, (4) quick coupler, (5) socket, (6) control cable, (7) guide roller, (8), (9) information decal

Three-way valve (2) – figure (3.9) activates these circuits. This valve's lever can be placed in two positions:

- 1 - the trailer's tipping circuit is opened - circuit (A),
- 2 - the second trailer's tipping circuit is opened – circuit (B).

On the connection conduit, in the vicinity of plug (4), there is a decal (8) identifying the supply conduit of the hydraulic tipping system.



ATTENTION

Cut-off valve (3) – figure (3.9) limits the tipping angle of the load box when tipped to the rear. The length of the cable (6) controlling this valve is factory adjusted by the Manufacturer and must not be changed when the trailer is used.



TIP

The hydraulic system of the trailer is filled with L-HL32 Lotos hydraulic oil.

3.2.5 SUPPORT HYDRAULIC SYSTEM

The parking stand hydraulic system extends the stand to support the trailer disconnected from the tractor or when it is parked in the garage after use. Using the parking stand hydraulic system, the drawbar height can be adjusted when hitching and unhitching the trailer. The parking stand hydraulic system is supplied with oil by the tractor hydraulics. The parking stand is extended or withdrawn by extending or withdrawing a hydraulic cylinder. Hydraulic oil manifold of the tractor's external hydraulic system controls the support cylinder.

Two types of hydraulic supports are used in the trailer:

- straight hydraulic support – figure (3.9) - standard equipment,
- shear type hydraulic support – figure (3.10) – optional equipment.

Lowering the straight hydraulic support (1) is done by opening the valve (3) on the trailer drawbar. Hydraulic oil supplied from the hydraulic manifold extends the cylinder ram to the desired height. After the pressure in hydraulic conduit is reduced, withdrawal of the parking stand to transport position is forced by means of springs - Figure (3.9). Hydraulic conduit which controls straight support is marked with decal (4) near the connector. The valve (3) locks the support in a fixed position.

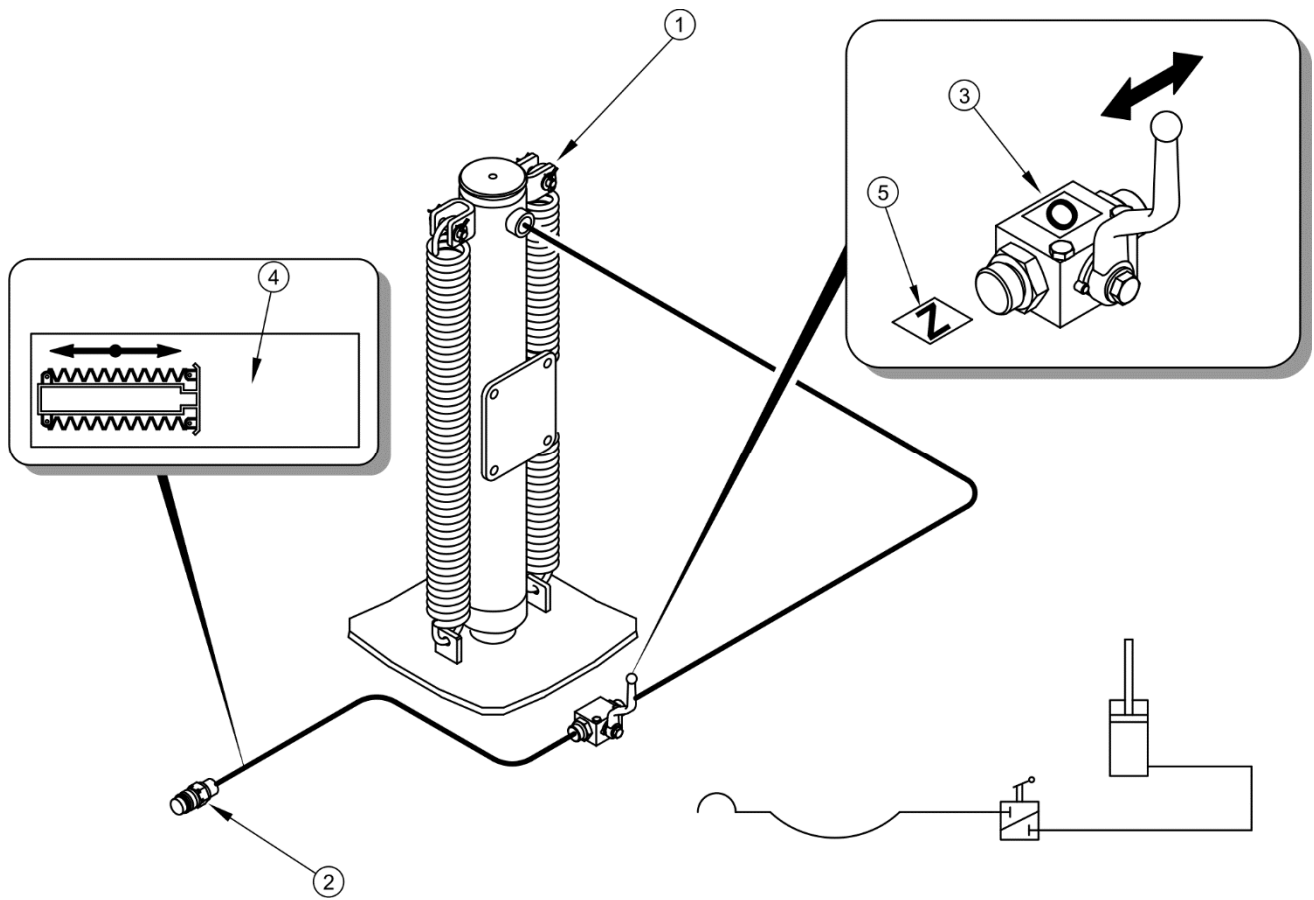

FIGURE 3.10 Design and diagram of the hydraulic system of the straight support

(1) hydraulic support, (2) quick coupler, (3) valve, (4), (5) information decals



TIP

The hydraulic system of the support is filled with L-HL32 Lotos hydraulic oil.

Hydraulic system of shear type drawbar support – figure (3.10) consists of return conduit (1) and supply conduit (2), control valve and cylinder (4). Hydraulic oil delivered from the tractor hydraulic manifold to line (2) extends the cylinder piston lowering the support. The support is raised to transport position when oil under pressure is supplied to conduit (1).

The support can be lowered or raised only when valve (5) is set in „O” position - open. When the valve is set in „Z” position – closed, the support is locked in a given position.

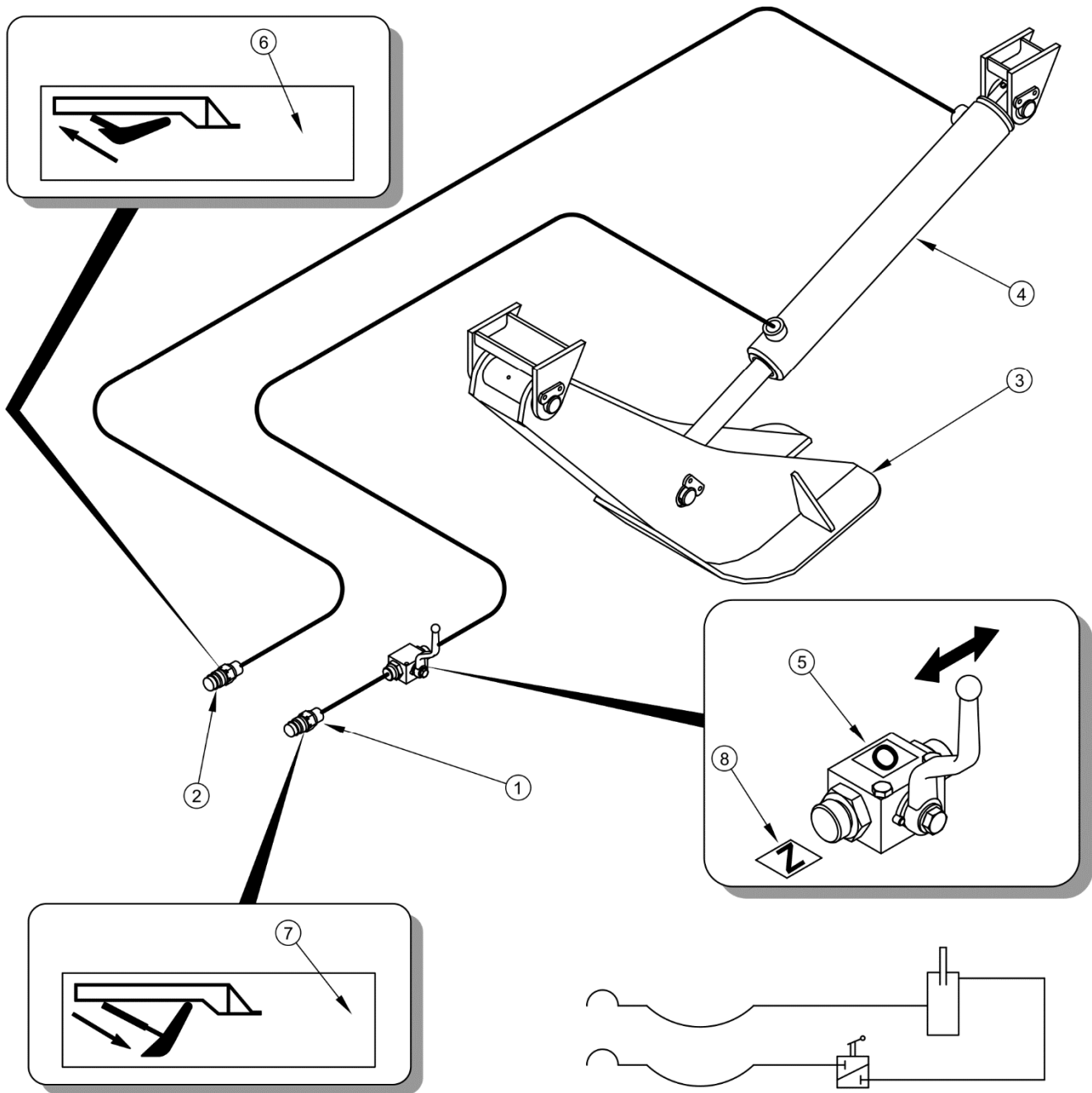

FIGURE 3.11 Design and diagram of the shear type support hydraulic system

(1) return conduit, (2) supply conduit, (3) shear type support, (4) cylinder, (5) - (8) information decals

3.2.6 TAILGATE HYDRAULIC SYSTEM

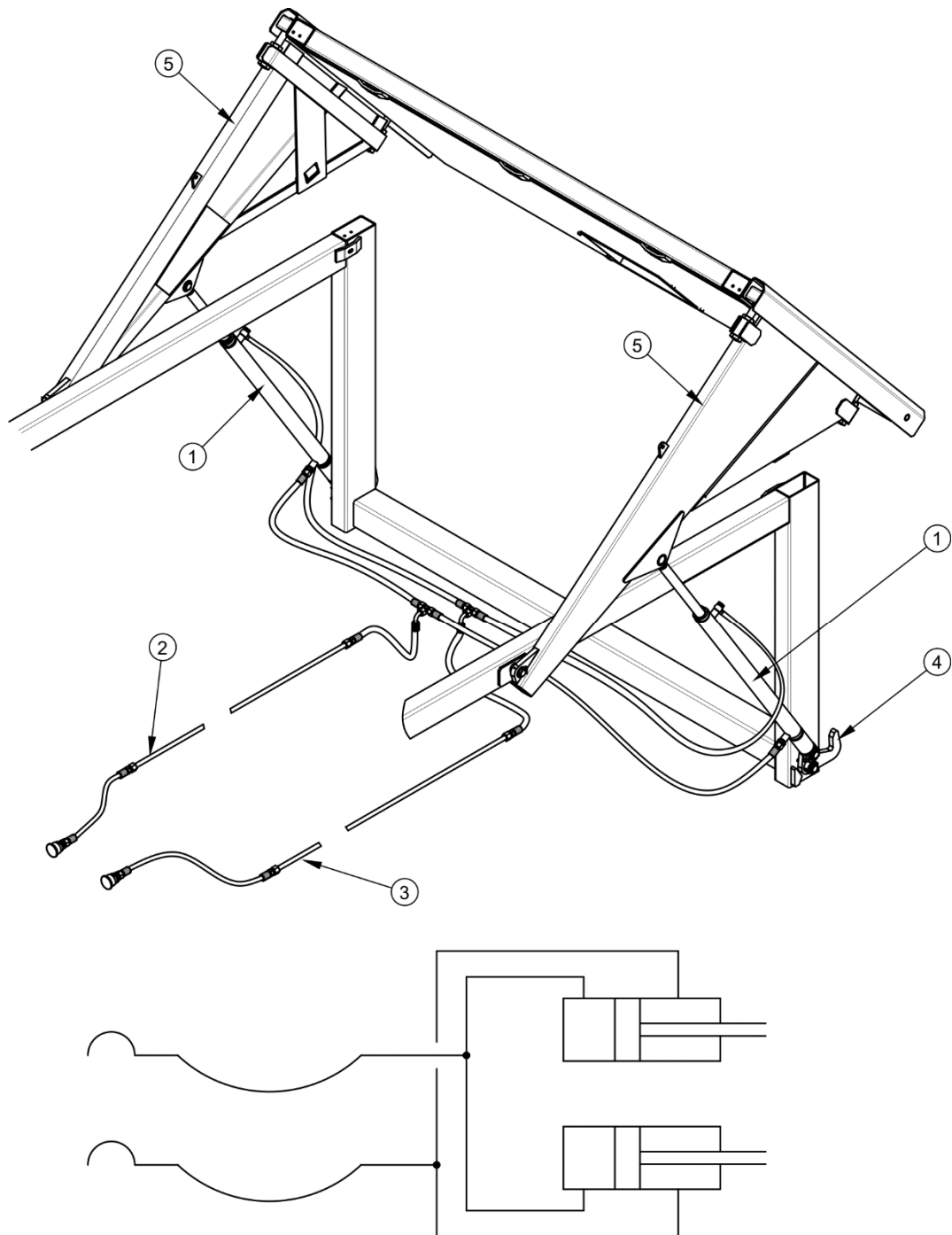

FIGURE 3.12 Design and diagram of the tailgate hydraulic system

(1) hydraulic cylinder, (2) supply conduit, (3) return conduit, (4) locking hook, (5) tailgate wing

Tailgate hydraulic system is used to raise and lower the trailer tailgate and control the operation of locking hooks (4).

The hydraulic system is supplied with oil from the tractor external hydraulic system. Through hydraulic conduits (2) terminated with quick-couplers pressurised oil is fed to hydraulic cylinders (1), which open or close the tailgate.

Tailgate is controlled from the tractor cab by means of the manifold lever of the tractor's external hydraulic system. When raising the tailgate the locking hooks (4) unlock the tailgate, then cylinders raise it by with two wings (5). When closing, the cylinders lower the load box, and in the final phase locking hooks (4) lock the load box.

3.2.7 PARKING BRAKE

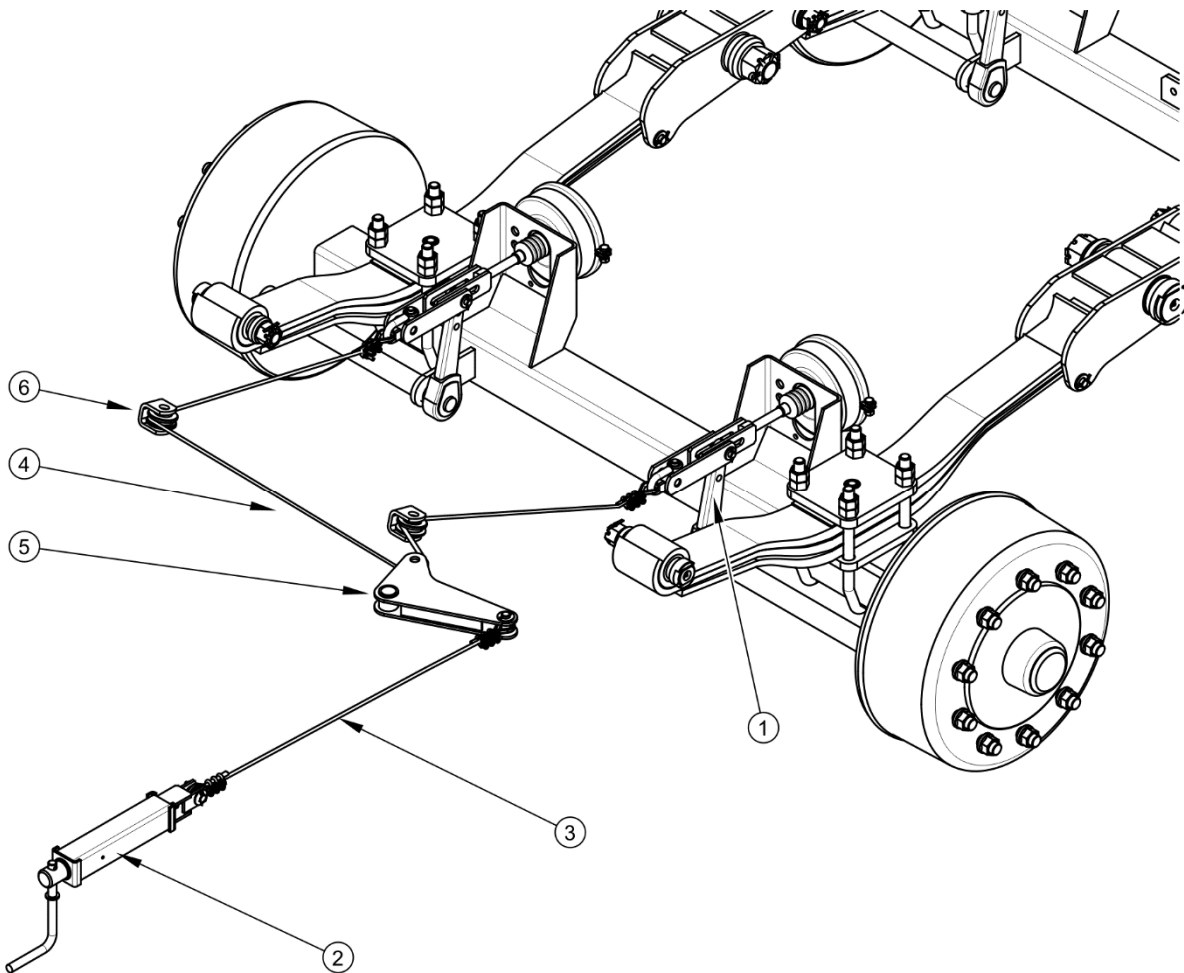

FIGURE 3.13 Parking brake design

(1) expander arm, (2) brake crank mechanism (3) steel cable I, (4) steel cable II (5) lever, (6) guide roller

The parking brake is used for immobilising the trailer while parking. The design of the system is shown in figure (3.13). The brake crank mechanism (2) is welded to the left longitudinal

member of the lower frame on the front of the trailer. Wheel axle expander arm levers (1) are connected to the lever (5) by means of cable II (4) through guide rollers (6). Lever (5) is connected to the brake crank mechanism (2) by means of steel cable I (3).

Tensioning cable I (3) (turning the crank mechanism clockwise), causes deflection of the lever (5) and tension of cable II (4) causing a deflection of the brake expander arms (1), which immobilize the trailer by parting the brake shoes.

3.2.8 LIGHTING SYSTEM

The trailer electrical system is designed for supply from direct current source of 12 V. Connection of the trailer electrical system with the tractor should be made through an appropriate connection lead.

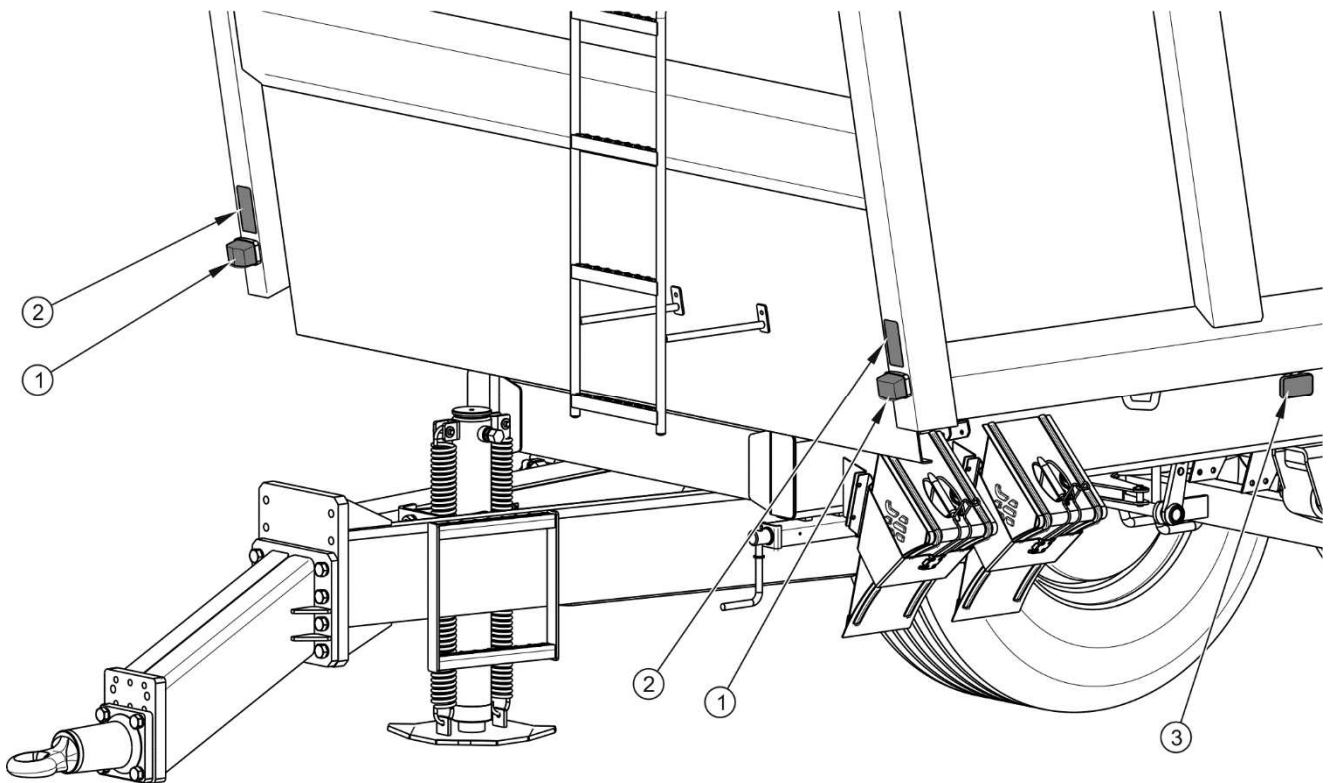

FIGURE 3.14 Positioning of electrical components and reflectors at the front

(1) front parking light, (2) front white reflector, (3) side parking light

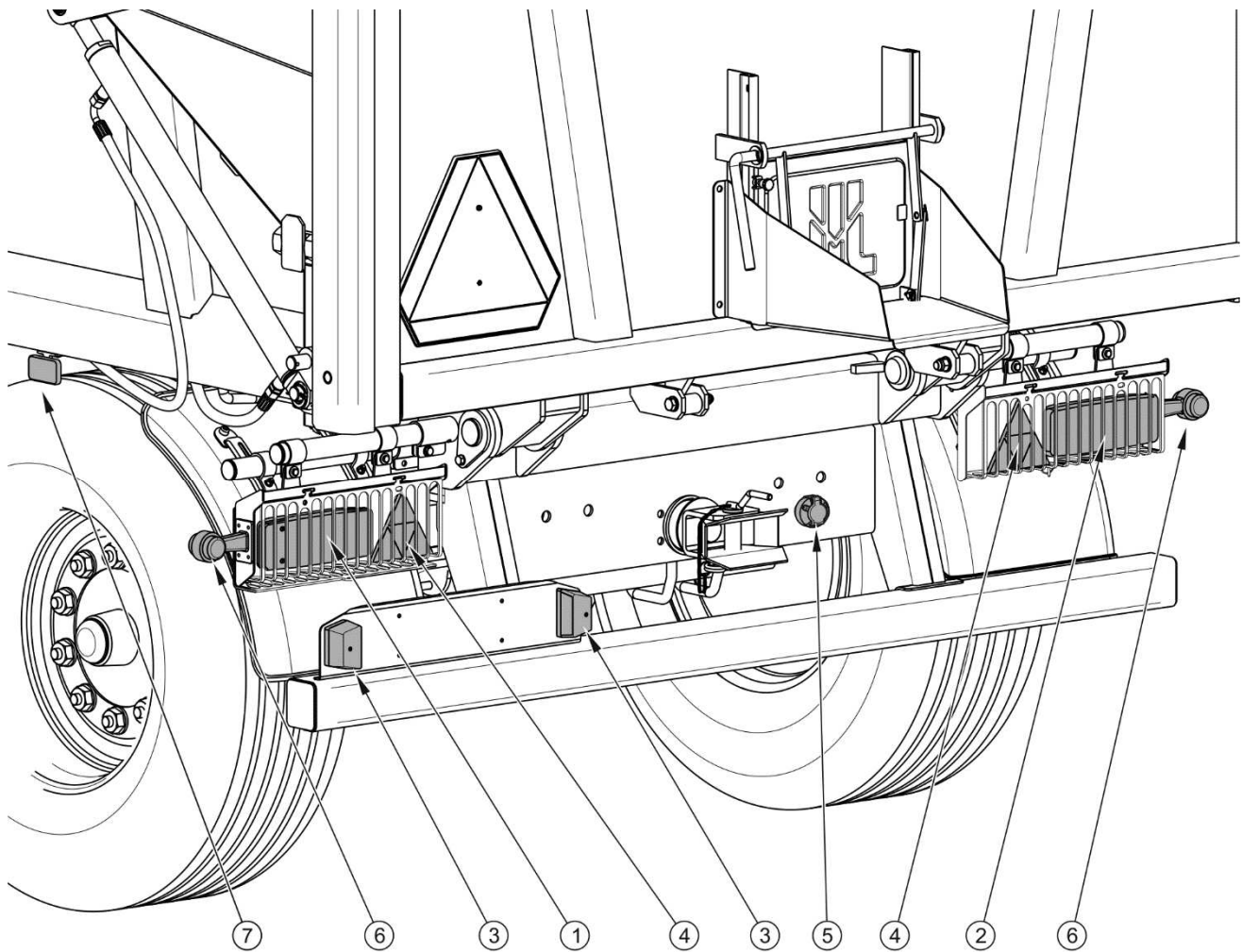

FIGURE 3.15 Positioning of electrical components and reflectors at the back

(1) rear left lamp assembly, (2) rear right lamp assembly (3) license plate light, (4) reflective warning triangle, (5) 7-pin socket (6) rear clearance lamp, (7) side parking light

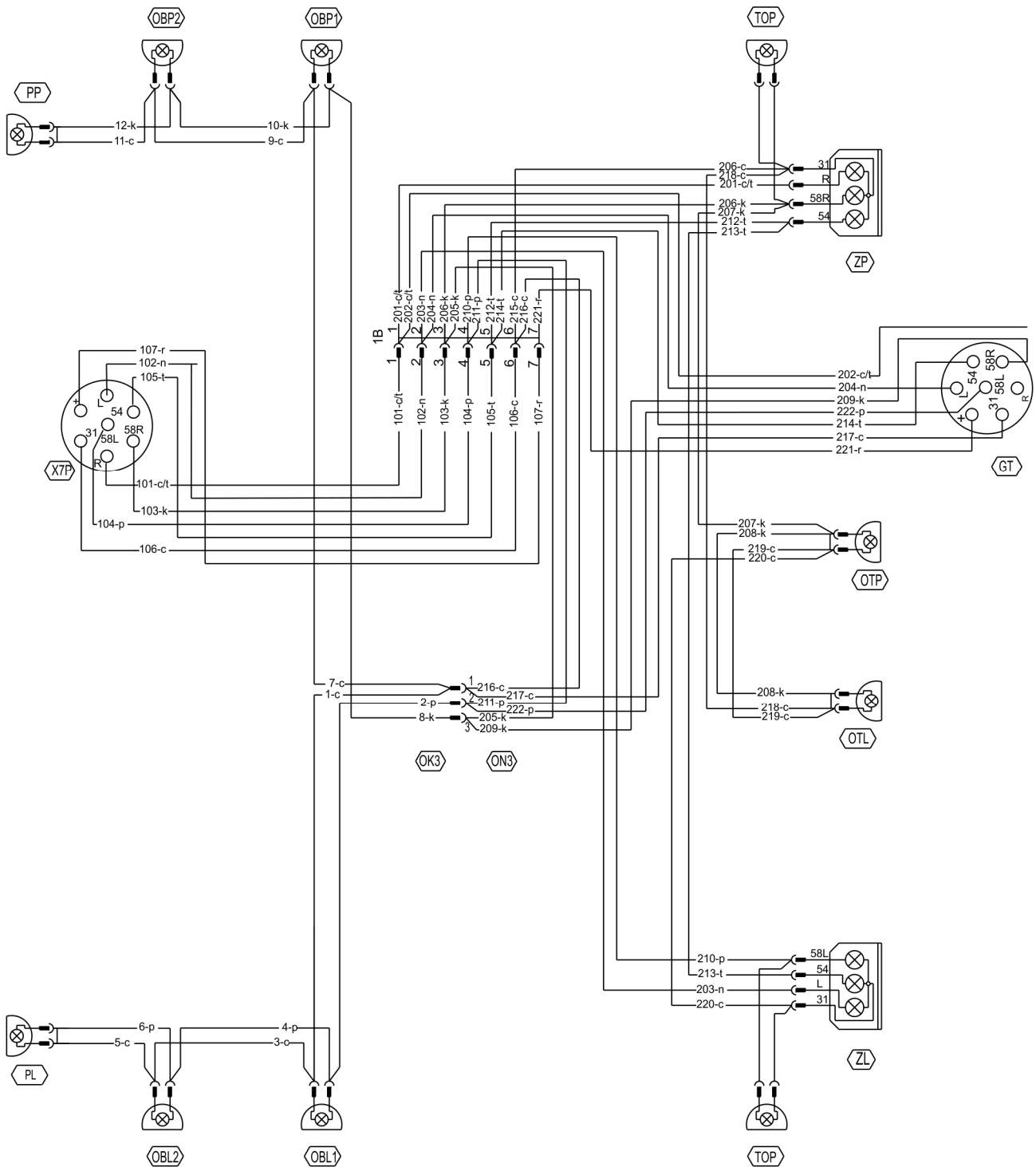

FIGURE 3.16 Electrical system schematic diagram, the versions without the side lamps

Marking according to table (3.2), (3.3) and (3.4)

TABLE 3.2 List of electrical component markings

SYMBOL	NAME
ZP	Rear right lamp assembly
ZL	Rear left lamp assembly
X7P	Front seven pin socket
GT	Rear seven pin socket
OTP	Right license plate light
OTL	Left license plate light
PP	Front right parking light
PL	Front left parking light
TOP	Rear right clearance light
TOL	Rear left clearance light
OBL	Left side clearance lamp
OBP	Right side clearance lamp

TABLE 3.3 Marking of connections of GT and X7P sockets

MARKING	FUNCTION
31	Ground
+	Power supply +12V (not used)
L	Left indicator
54	STOP light
58L	Rear left parking light
58R	Rear right parking light
R	Right indicator

TABLE 3.4 Lead colour marking

MARKING	COLOUR
B	White
C	Black
K	Red
N	Blue
P	Orange
T	Green
C/T	Black and green
R	Pink

SECTION

4

CORRECT USE

4.1 PREPARING FOR WORK BEFORE THE FIRST USE

4.1.1 CHECKING THE TRAILER AFTER DELIVERY

The manufacturer guarantees that the trailer is fully operational and has been checked according to quality control procedures and is ready for normal use. This does not release the user from an obligation to check the machine's condition after delivery and before first use. The machine is delivered to the user completely assembled.

Before commencing work, machine operator must inspect the technical condition of the trailer and prepare it for the first start-up. The user must carefully read this Operator's Manual and observe all recommendations, understand the design and the principle of machine operation.



ATTENTION

Before hitching to tractor and using the trailer, the user must carefully read this Operator's Manual and observe all recommendations.

External inspection

- ➔ Check completeness of machine (standard and optional equipment).
- ➔ Check condition of protective paint coat,
- ➔ Inspect trailer's individual components for mechanical damage resulting from incorrect transport (dents, piercing, bent or broken components).
- ➔ Check technical condition of tyres and tyre pressure.
- ➔ Check technical condition of elastic hydraulic conduits.
- ➔ Check technical condition of pneumatic conduits.
- ➔ Check that there are no hydraulic oil leaks.
- ➔ Check electric lamps.
- ➔ Check tipping cylinder, tailgate cylinders and shear type support cylinders for hydraulic oil leaks.

4.1.2 PREPARING THE TRAILER FOR THE FIRST HITCHING TO TRACTOR

Preparation

- ➔ Check all the trailer's lubrication points, lubricate the machine as needed according to recommendations provided in section 5.
- ➔ Check if the nuts and bolts fixing the wheels are properly tightened.
- ➔ Drain air tank of the braking system.
- ➔ Ensure that pneumatic, hydraulic and electric connections in agricultural tractor are according to the requirements, if not the trailer should not be hitched to the tractor.
- ➔ Adjust the height of the drawbar eye to the tractor hitch
 - ⇒ A detailed description can be found in section 5.

Test start

If all the above checks have been performed and there is no doubt as to the trailer's good technical condition, it can be connected to tractor. Start the tractor, check all systems and conduct test run of trailer without load (no load in load box). It is recommended that the inspection is conducted by two people, one of which should always remain in the tractor cab. Test drive should be conducted according to the sequence shown below.

- ➔ Connect the trailer to appropriate hitch on agricultural tractor.
- ➔ Connect conduits of braking, electrical and hydraulic systems.
- ➔ Switch on individual lights, check correct operation of electrical system.
- ➔ Turn hydraulic tipping system valve to position 1. Conduct test tipping of load box to the rear.
- ➔ Actuate and check if tailgate control system operates correctly.
- ➔ When moving off check if the main brakes operate correctly.
- ➔ Perform test drive.



TIP

Operating activities: hitching to/unhitching from tractor, adjustment of drawbar position, tipping of load box etc. are described in detail in further parts of the Operator's Manual, in sections 4 and 5.

If during test run worrying symptoms occur such as:

- noise and abnormal sounds originating from the abrasion of moving elements of the trailer design,
- hydraulic oil leak,
- pressure drop in braking system,
- incorrect operation of hydraulic and/or pneumatic cylinders,

or other faults, find the cause of the problem. If a fault cannot be rectified or the repair could void the guarantee, please contact the dealer for additional clarifications or to make a repair.

DANGER



Careless and incorrect use and operation of the trailer, and non-compliance with the recommendations given in this operator's manual is dangerous to your health.

The trailer must never be used by persons who are not authorised to drive agricultural tractors, including children and people under the influence of alcohol or other drugs.

Non-compliance with the safety rules of this Operator's Manual can be dangerous to the health and life of the operator and others.

After completion of test drive check tightness of wheel nuts.

4.2 HITCHING AND UNHITCHING THE TRAILER FROM TRACTOR

Ensure that pneumatic, hydraulic and electric connections and the hitch of agricultural tractor are according to the Manufacturer's requirements, if not the trailer should not be hitched to the tractor.

In order to hitch the trailer to the tractor, perform the actions below in the sequence presented. Machine must be immobilised by parking brake.

Hitching to tractor

- ➔ Immobilise trailer with parking brake.
- ➔ Position agricultural tractor directly in front of drawbar eye.

- ➔ Reverse tractor and connect the conduit marked with decal (17)– table (2.1) (straight hydraulic support). If the trailer is equipped with shear type hydraulic support, connect the hydraulic conduits marked with decals (18) and (19) - Table(2.1).
- ➔ Using the support set the drawbar eye at such a height so it is possible to hitch the machines.
 - ⇒ Operate the selective control valve on the tractor to raise or lower the drawbar eye, until the correct height is achieved
- ➔ Reverse tractor, hitch trailer, check coupling lock protecting machine against accidental unhitching.
 - ⇒ If the agricultural tractor is equipped with an automatic coupler, ensure that the hitching operation is completed and that drawbar eye is secured.
 - ⇒ When the trailer is hitched to tractor, the support must be folded as close as possible to the drawbar by maximally withdrawing the hydraulic cylinder piston.
 - ⇒ When the support is completely folded, set manifold lever in tractor to "neutral" position.
- ➔ Turn off tractor engine. Ensure that unauthorised persons do not have access to the tractor cab.
- ➔ Connect pneumatic system conduits (applies to double conduit systems):
 - ⇒ Connect pneumatic conduit marked yellow with yellow socket in tractor.
 - ⇒ Connect pneumatic conduit marked red with red socket in tractor.
- ➔ Connect pneumatic system conduits (applies to single conduit pneumatic system):
 - ⇒ Connect pneumatic conduit marked black with black socket in tractor.
- ➔ Connect hydraulic brake system (applies to trailer version with hydraulic brake).

- ⇒ Hydraulic brake system conduit is marked with information decal (13) – table (2.1).
- ➔ Connect hydraulic tipping system conduit.
 - ⇒ Hydraulic tipping system conduit is marked with information decal (14) – table (2.1).
- ➔ Connect main lead supplying electrical lighting system.

DANGER



When hitching, there must be nobody between the trailer and the tractor. When hitching the machine, tractor driver must exercise due caution and make sure that nobody is present in the hazard zone.

When connecting the hydraulic conduits to the tractor, make sure that the hydraulic system of the tractor and the hydraulic system of the trailer are not under pressure.

Ensure sufficient visibility during hitching.

During connection of braking system conduits (pneumatic double conduit) the correct sequence of conduit connection is very important. First connect the yellow connector to yellow socket in the tractor and only then connect the red connector to the red socket in the tractor. Once the 2nd conduit is connected, the braking system will switch to normal mode of operation (disconnection or interruption of the conduits causes the trailer's braking system control valve to automatically apply brakes). Conduits are marked with coloured protective covers, which identify the appropriate system conduit.

ATTENTION



Trailer may only be hitched to a tractor that has the appropriate hitch, connection sockets for braking, hydraulic and electrical systems, and hydraulic oil in both machines is of the same type and may be mixed.

When hitching is completed, secure the electrical leads and hydraulic and braking system conduits in such a way that they do not become entangled in tractor's moving parts and are not at the risk of breaking or being severed when making turns.

Ensure compatibility of oils in tractor hydraulic system and in the trailer hydraulic system.

Unhitching the trailer

In order to unhitch the trailer from the tractor follow these steps.

- ➔ Immobilise tractor and trailer with parking brake.
- ➔ Place chocks under trailer wheel.
 - ⇒ Wheel chocks shall be so placed that one is in front of the wheel and the second is behind wheel of rear axle - see section 2.
- ➔ Lower support to the ground.
 - ⇒ Operate the manifold on the tractor in the direction corresponding to the support cylinder piston rod extension (hydraulic support).
 - ⇒ When the support is lowered, set the manifold lever in tractor to "neutral" position (hydraulic support).
 - ⇒ Close the valve on the trailer drawbar to lock the hydraulic support in a fixed position. (hydraulic support).
 - ⇒ If the trailer is equipped with a mechanical support, secure it with locking pin provided after adjusting the drawbar to correct height.
- ➔ Turn off tractor engine. Ensure that unauthorised persons do not have access to the tractor cab.
- ➔ Disconnect all hydraulic support and tipping system lines from tractor.
- ➔ Disconnect electric lead.
- ➔ Disconnect pneumatic system conduits (applies to double conduit pneumatic system).
 - ⇒ Disconnect pneumatic conduit marked red.
 - ⇒ Disconnect pneumatic conduit marked yellow.
- ➔ Disconnect pneumatic system conduits (applies to single conduit systems):
 - ⇒ Disconnect pneumatic conduit marked black.
- ➔ Disconnect hydraulic brake system conduit (applies to trailer version with hydraulic brake system).
- ➔ Protect conduit ends with covers. Place conduit plugs in appropriate sockets.

- ➔ Unlock tractor hitch and disconnect trailer drawbar from tractor hitch and drive tractor away.



DANGER

Exercise caution when unhitching the trailer from the tractor. Ensure good visibility. Unless it is necessary, do not go between tractor and trailer.

Before disconnecting conduits and drawbar eye, close tractor cab and secure it against access by unauthorised persons. Turn off tractor engine.

4.3 HITCHING AND UNHITCHING THE SECOND TRAILER

A second trailer may only be hitched if it is a machine built on a dual axle chassis and if it fulfils all requirements specified in section 1. Hitching the second trailer to the tractor - trailer unit requires experience in driving an agricultural tractor with a trailer. While hitching the second trailer, it is recommended to use the help of another person to guide the tractor driver.



DANGER

When hitching, there must be nobody between the trailers. Person assisting in hitching the machines should stand outside the area of danger and be visible to the tractor driver at all times.

Hitching the second trailer

- ➔ Position the tractor with the first trailer hitched directly in front of the second trailer's drawbar.
- ➔ Immobilise the second trailer with parking brake.
- ➔ Remove securing cotter pin (4) and take out hitch pin (3) in the first trailer - figure (4.1).
- ➔ Adjust the height of the drawbar (2) of the second trailer in such a manner as to enable hitching the machines.
- ➔ Reversing tractor, drive the rear hitch of the first trailer onto the drawbar of the second trailer.

- ⇒ If the trailer is equipped with an automatic rear hitch, ensure that the hitching operation is completed and that drawbar eye of the second trailer is secured.

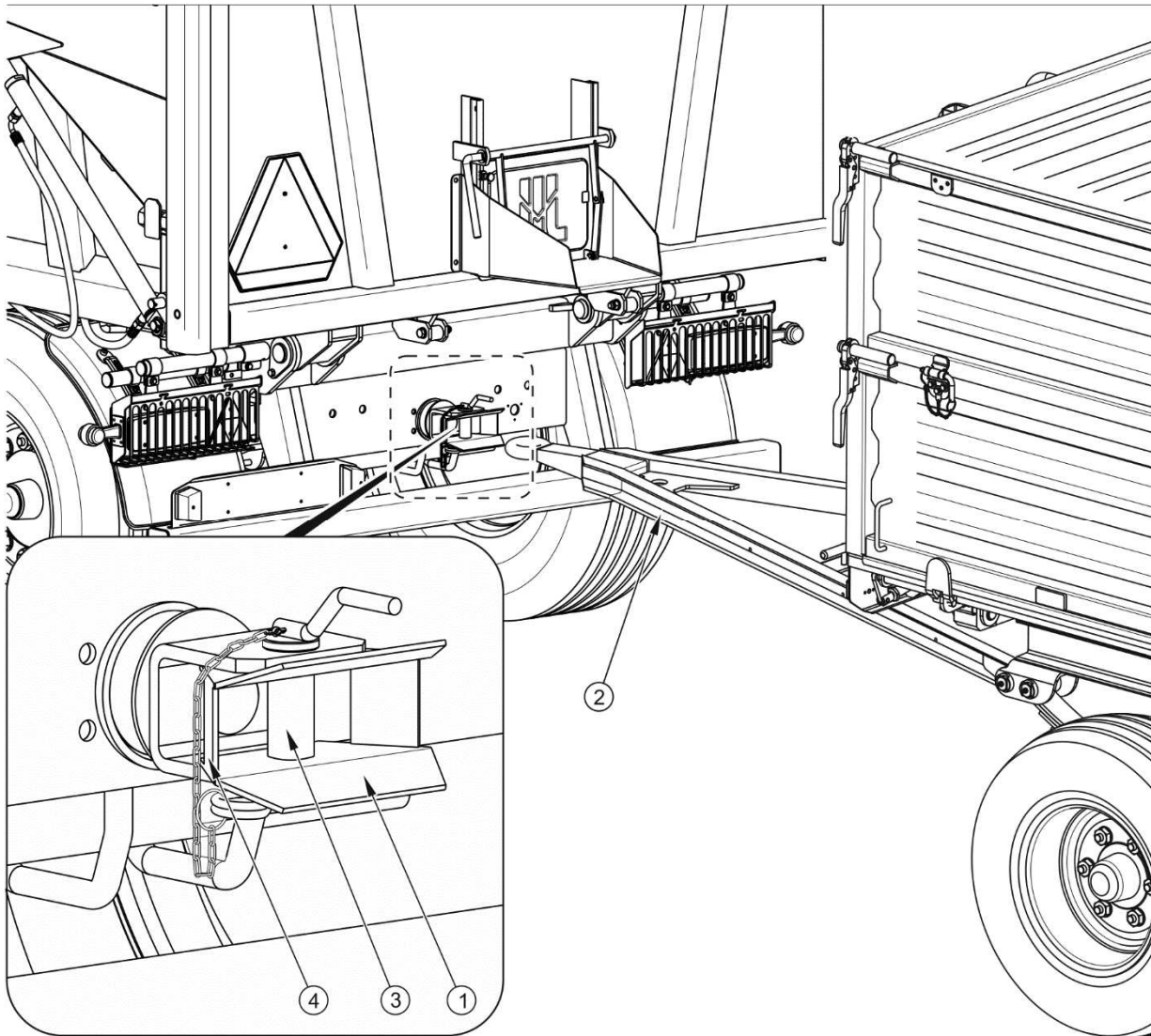

FIGURE 4.1 Coupling second trailer

(1) hitch body, (2) the second trailer drawbar, (3) hitch pin, (4) chain with locking cotter pin

- ➔ Insert drawbar pin and securing cotter pin.
- ➔ Connect conduits of hydraulic system and pneumatic system and electrical leads according to instructions contained in section (4.2).

Unhitching the second trailer

- ➔ Immobilise tractor and trailer with parking brake.

- ➔ Turn off tractor engine. Ensure that unauthorised persons do not have access to the tractor cab.
- ➔ Disconnect lines of pneumatic, hydraulic and electrical systems according to instructions contained in section (4.2).
- ➔ Unlock the pin of the hitch of the first trailer. Remove the pin and drive tractor away.

**ATTENTION**

Do NOT hitch a second trailer constructed on any chassis except dual axle.

4.4 LOADING AND SECURING LOAD

4.4.1 GENERAL INFORMATION ABOUT LOADING

Before beginning loading make certain that the tailgate and chute slide gate are properly closed and secured. The trailer must be positioned to travel forwards and be hitched to the tractor. Loading should only take place, when trailer is placed on flat level surface and hitched to tractor. If the trailer is equipped with tarpaulin cover, it should be rolled.

**ATTENTION**

When a tailgate is tightly closed, that securing hooks must fully engage the rear gate securing pin.

Regardless of the type of load carried, the user is obliged to secure it in such a manner that the load is unable to spread and cause contamination of the road. If this is impossible, do NOT transport this type of load.

Materials, which in contact with painted or steel surfaces may cause damage, should be transported in sealed packaging (bags, boxes, barrels, etc.). After unloading, the load box should be thoroughly cleaned with a strong jet of water.

If the transported materials exert high local pressure on the load box platform it should be protected against damage using thick planks, plywood or other materials of similar properties.



ATTENTION

Always try to distribute the load uniformly in the load box.
Do NOT exceed the trailer's maximum carrying capacity.

Due to the various density of materials, using the total load box capacity may lead to exceeding permissible carrying capacity of the trailer. Guideline specific weight of selected materials is shown in table (4.1). Take care not to overload the trailer.

TABLE 4.1 Guideline weights by volume of selected materials

TYPE OF MATERIAL	WEIGHT BY VOLUME kg/m ³
Root crops: raw potatoes steamed crushed potatoes dried potatoes sugar beet - roots fodder beet - roots	700 - 820 850 - 950 130 - 150 560 - 720 500 - 700
Organic fertilisers: old manure mature manure fresh manure compost dry peat	700 - 800 800 - 900 700 - 750 950 – 1 100 500 - 600
Mineral fertilisers: ammonium sulphate potash salt super phosphate basic slag phosphate potassium sulphate milled lime fertiliser	800 - 850 1 100 – 1 200 850 – 1 440 2 000 – 2 300 1 200 – 1 300 1 250 - 1 300
Building materials: cement dry sand	1 200 – 1 300 1 350 – 1 650

TYPE OF MATERIAL	WEIGHT BY VOLUME kg/m ³
wet sand	1 700 – 2 050
solid bricks	1 500 – 2 100
hollow bricks	1 000 – 1 200
stones	1,500 – 2,200
soft wood	300 - 450
hard sawn timber	500 - 600
impregnated timber	600 - 800
steel structures	700 – 7,000
milled burnt lime	700 - 800
cinders	650 - 750
gravel	1,600 – 1,800
Straw litter and bulk feeds:	
meadow hay dried in the swath	10 - 18
hay wilted in the swath	15 - 25
hay in gathering trailer (dry wilted)	50 - 80
wilted cut hay	60 - 70
dry baled hay	120 - 150
wilted baled hay	200 - 290
stored dry hay	50 - 90
stored cut hay	90 - 150
clover (lucerne) wilted in the swath	20 - 25
clover (lucerne) cut wilted on trailer	110 - 160
clover (lucerne) wilted on gathering trailer	60 - 100
dry stored clover	40 - 60
cut dry stored clover	80 - 140
dry straw in round bales	8 - 15
damp straw in round bales	15 - 20
cut damp straw in bulk trailer	50 - 80
cut dry straw in bulk trailer	20 - 40
cut dry straw in gathering trailer	50 - 90
cut dry straw in stack	40 - 100
baled straw (lightly crushed)	80 - 90

TYPE OF MATERIAL	WEIGHT BY VOLUME kg/m ³
baled straw (heavily crushed)	110 - 150
cereal mass in round bales	20 - 25
cut cereal mass in bulk trailer	35 - 75
cut cereal mass in gathering trailer	60 - 100
green fodder in swath	28 - 35
cut green fodder in bulk trailer	150 - 400
green fodder in gathering trailer	120 - 270
fresh beet leaves	140 - 160
cut fresh beet leaves	350 - 400
beet leaves in gathering trailer	180 - 250
Concentrated feeds and mixed feeds:	
stored chaff	200 - 225
pressed cake	880 - 1 000
milled dry feed	170 - 185
mixed feeds	450 - 650
mineral mixtures	1 100 - 1 300
ground oats	380 - 410
wet sugar beet pulp	830 - 1 000
pressed sugar beet pulp	750 - 800
dry sugar beet pulp	350 - 400
bran	320 - 600
bone meal	700 - 1 000
pasture salt	1 100 - 1 200
molasses	1 350 - 1 450
silage (pit silo)	650 - 1 050
hay silage (tower silo)	550 - 750
Seeds and grains:	
beans	750 - 850
mustard	600 - 700
peas	650 - 750
lentils	750 - 860
runner beans	780 - 870

TYPE OF MATERIAL	WEIGHT BY VOLUME kg/m ³
barley	600 - 750
clover	700 - 800
grass	360 - 500
maize	700 - 850
wheat	720 - 830
oil seed rape	600 - 750
linseed	640 - 750
lupins	700 - 800
oats	400 - 530
lucerne	760 - 800
rye	640 - 760
Others:	
dry soil	1,300 – 1,400
wet soil	1,900 – 2,100
fresh peat	700 - 850
garden soil	250 - 350

Source: "Technology of machine work in agriculture", PWN, Warszawa 1985

Loading should be carried out by a person experienced in this type of work and having appropriate authorisation for operating equipment (if required).

ATTENTION



The trailer is also designed for transport of harvested crops and agricultural products (volumetric or loose). It is permissible to transport other loads (timber, building materials packed loads), on the condition of securing the load box against damage (abrasion of paint covering, corrosion etc.).

DANGER



The load on the trailer must be secured against slipping and contaminating the road during travel. If it is not possible to properly secure the load, do not transport it.
During loading the trailer, the drawbar eye and the tractor hitch are subjected to great vertical loads.

Bulk materials

Loading bulk materials is normally conducted with the use of loaders or conveyors and possibly loading manually. Do not load bulk materials to a height greater than that of side walls or extensions. On completion of loading, the load should be evenly spread over the whole surface of the load box.

Oilseed rape or seeds of other plants of very small size or powder materials can be transported provided the load box is properly sealed in places where gaps are bigger than the seed diameter or other carried material. Profiled rubber seals, silicone sealers, plastic wrap, rope or textile materials are recommended materials to provide sealing of the load box.

Additionally it is essential to protect load with tarpaulin cover. It protects the load against spilling during travel, being blown away by the wind and also protects load against moisture. This is particularly dangerous in the case of bulk materials. They may absorb a significant amount of water, which may increase the bulk of the load during travel. In extreme cases the gross weight of the trailer may exceed the permissible vehicle gross weight.

Some bulk loads (e.g. building materials, such as gravel or slag) may cause more rapid damage to paintwork.

Loads of pieces or solid lumps

Loads of pieces or solid lumps are generally hard materials of significantly greater dimensions than bulk loads (stones, coal, bricks and ballast). These materials without prior preparation of the load box may cause indentation of the floor or walls and abrasion of paintwork. To provide necessary protection, lay thick plywood, hard particle board, thick planks or other materials of similar properties on the load box platform and possibly side walls and extensions. Non-compliance with the instructions provided could invalidate the warranty. Loading of material in pieces or solid lumps must be from a low height. The load must not fall with great force on the floor of the load box, even if it is protected.

Hazardous loads

According to the European ADR agreement concerning the international road transport of hazardous materials, the transport of this type of load (defined in detailed by this agreement) is forbidden with the use of agricultural trailers. The only exception are plant protection materials and artificial fertilisers, which may be transported on agricultural trailers on the

condition that they are transported in the appropriate packaging and in quantities envisaged by the ADR agreement.

DANGER



If it is necessary to carry permitted hazardous materials, acquaint yourself with the regulations concerning transport of hazardous materials in force in the given country and also the regulations of the ADR agreement.

Carefully read the information leaflets provided by the load manufacturer and observe the instructions for transporting and handling the load. Ensure whether during loading work it is necessary to apply additional personal protection (masks, rubber gloves etc.)

High volume loads

High volume loads (light with large volumes) such as hay, presses blocks or bales, straw, silage etc. should be loaded with appropriate fittings: bale grabs, forks etc. Load may be loaded even exceeding the height of load box extensions but particular attention should be paid to the trailer stability and the proper attachment and securing of the load. Remember that higher loading has a negative effect on trailer stability.

Loads in packaging

Loads transported in packaging (boxes, sacks) must be laid closely side-by-side beginning from the front side of the trailer. If it is essential to lay several layers, particular groups should be stacked alternately (in block system). The load must be laid tightly together and on the whole surface of the trailer floor. Otherwise, the load will move during travel. Due to the trailer design (the load box designed for the transport of agricultural crops and products, lack of load securing points), materials in packaging may not be loaded above the top of the walls or extensions of load box. If the trailer is equipped with net extensions, the height of the load may not exceed the upper edge of the sides. A higher load level may move during travel and cause significant damage to the net extensions and the load may spill.

DANGER

If there is a danger of load packaging moving, do NOT transport this type of material. A moving load constitutes a serious hazard during travel for the tractor driver and other road users.



Overloading the trailer, erroneous loading and securing of the load is the most frequent cause of accidents during transport.

The load must be arranged in such a way that it does not threaten the stability of the trailer and does not hinder driving.

Ensure that during unloading / loading or raising the load box nobody is near the trailer. Before tipping the load box ensure proper visibility and make certain that there are no bystanders near the trailer.

The arrangement of the load may not cause an overload on the axle or hitch system of the trailer.

Materials which may cause corrosion of steel, chemical damage or react in any other way negatively affecting the trailer structure may be transported only on condition of appropriate load preparation. Materials must be tightly packed (in plastic foil sacks, plastic containers etc.). During transport, packaging contents may not come into contact with load box. Therefore, ensure the appropriate tightness of containers.

It is impossible to describe all methods of loading due to the diversity of materials, tools, means of fixing and securing a load. While working be guided by caution and own experience. The trailer user must carefully read the regulations concerning road transport and comply with them.

4.5 TRANSPORTING LOAD

When driving on roads, respect the road traffic regulations, exercise caution and prudence. Listed below are the key guidelines for driving the tractor and trailer combination.

- Before moving off, make sure that there are no bystanders, especially children, near the trailer or the tractor. Ensure that the driver has sufficient visibility.
- Make sure that the trailer is correctly hitched to the tractor and tractor's hitch is properly secured.
- Vertical load borne by the trailer drawbar eye affects the steering of the agricultural tractor.

- The trailer must not be overloaded, loads must be uniformly distributed so that the maximum permissible axle loads are not exceeded. The trailer's maximum carrying capacity must not be exceeded as this can damage the trailer and pose a risk to the operator or other road users.
- Permissible design speed and maximum speed allowed by road traffic law must not be exceeded. The towing speed should be adapted to the current road conditions, load carried by the trailer, road surface conditions and other relevant conditions.
- Trailer may be towed on slopes of up to 8° and unloading must take place only on a level surface.
- When not connected to the tractor, the trailer must be immobilised using parking brake and possibly also with chocks or other objects without sharp edges placed under the front and back wheels. Do NOT leave unsecured trailer. In the event of machine malfunction, pull over on the hard shoulder avoiding any risk to other road users and position reflective warning triangle according to traffic regulations.
- When driving on public roads, the trailer must be marked with a slow-moving vehicle warning sign attached to the rear wall of load box, if the trailer is the last vehicle in the group.
- While driving on public roads the trailer must be fitted with a certified or authorised reflective warning triangle.
- When driving, comply with all road traffic regulations, indicate an intention to turn using indicator lamps, keep all road lights and indicator lights clean at all times and ensure they are in good condition. Any damaged or lost lamps or indicator lights must be immediately repaired or replaced.
- Avoid ruts, depressions, ditches or driving on roadside slopes. Driving across such obstacles could cause the trailer or the tractor to suddenly tilt. This is of special importance because loaded trailer's centre of gravity is higher (especially a high volume load), which reduces safety. Driving near ditches or channels is dangerous as there is a risk of the wheels sliding down the slope or the slope collapsing.

- Speed must be sufficiently reduced before making a turn or driving on an uneven road or a slope.
- When driving, avoid sharp turns especially on slopes.
- Please note that the braking distance of the tractor and trailer combination is substantially increased at higher speeds and loads.
- Monitor trailer's behaviour when travelling on an uneven terrain, and adjust driving speed to road conditions, slow down early enough when turning.
- The trailer is designed to operate on slopes up to 8°. Driving trailer across ground with steeper slopes may cause the trailer to tip over as a result of loss of stability. Prolonged driving across steep ground may lead to loss of braking efficiency.



ATTENTION

Travelling with a high-volume load over ruts, ditches, roadside slopes etc. constitutes a great risk of overturning the trailer. Exercise particular caution.

4.6 UNLOADING

The trailer is equipped with hydraulic tipping system and suitable frame structure and the load box allowing tipping to the rear. Tipping of the load box is controlled from driver's cab using external tractor hydraulic system manifold.

Unloading of the trailer is performed in the following sequence:

- ➔ tractor and trailer must be placed to drive forwards on flat and hard ground,
- ➔ immobilise tractor with parking brake,
- ➔ open the trailer tailgate by means of hydraulic cylinders by operating a lever of the tractor hydraulic manifold,
- ➔ place the lever controlling the hydraulic tipping system circuits in position 1 -- tipping of the first trailer,
- ➔ initiate tipping of the load box using the selective control valve lever in the operator's cabin,
- ➔ after unloading, lower the load box and clean the floor edges,

- ➔ close the tailgate by operating the suitable hydraulic circuit in the tractor,
 - ⇒ Tailgate must be closed until it is secured by securing hooks,
- ➔ before moving off make sure that the tailgate is properly locked.



ATTENTION

When a tailgate is tightly closed, that securing hooks must fully engage the rear gate securing pin.

Do not unload the trailer when the second trailer is connected.

When unloading the second trailer, control valve of hydraulic tipping system should be switched to position 2 - tipping the second trailer.

DANGER



Before unloading the trailer, check that the bolts connecting the load box with the lower frame are properly secured.

Do not unload the trailer the second trailer is connected.

Do NOT tip load box in strong gusty winds conditions.

Tipping the load box must be done on hard and level ground.

Ensure that during unloading nobody is near tipped load box or load material pouring out.

Do NOT jerk the trailer forwards if load is bulky or reluctant to pour and does not unload.

Tipping may only be performed when trailer is hitched to tractor.

Do NOT move off or drive when load box is raised.

When closing the rear grain chute gate take particular care to avoid crushing fingers.

Rear load box wall is equipped with chute slide gate (1) – figure (4.3) and chute (2) (optional equipment) which is used for unloading loose materials. Chute design allows very accurate dosing of the material to packaging (sacks, boxes etc.). The opening gap can be controlled using lever (3). In order to do that loosen the bolt interlocking slide gate (4), open the slide as required and lock again using the bolt. During unloading through chute, load box must be raised slowly and smoothly. Raising the load box quickly will exert large pressure on the rear part of the load box due to displacement of the carried material and could compromise trailer's stability.

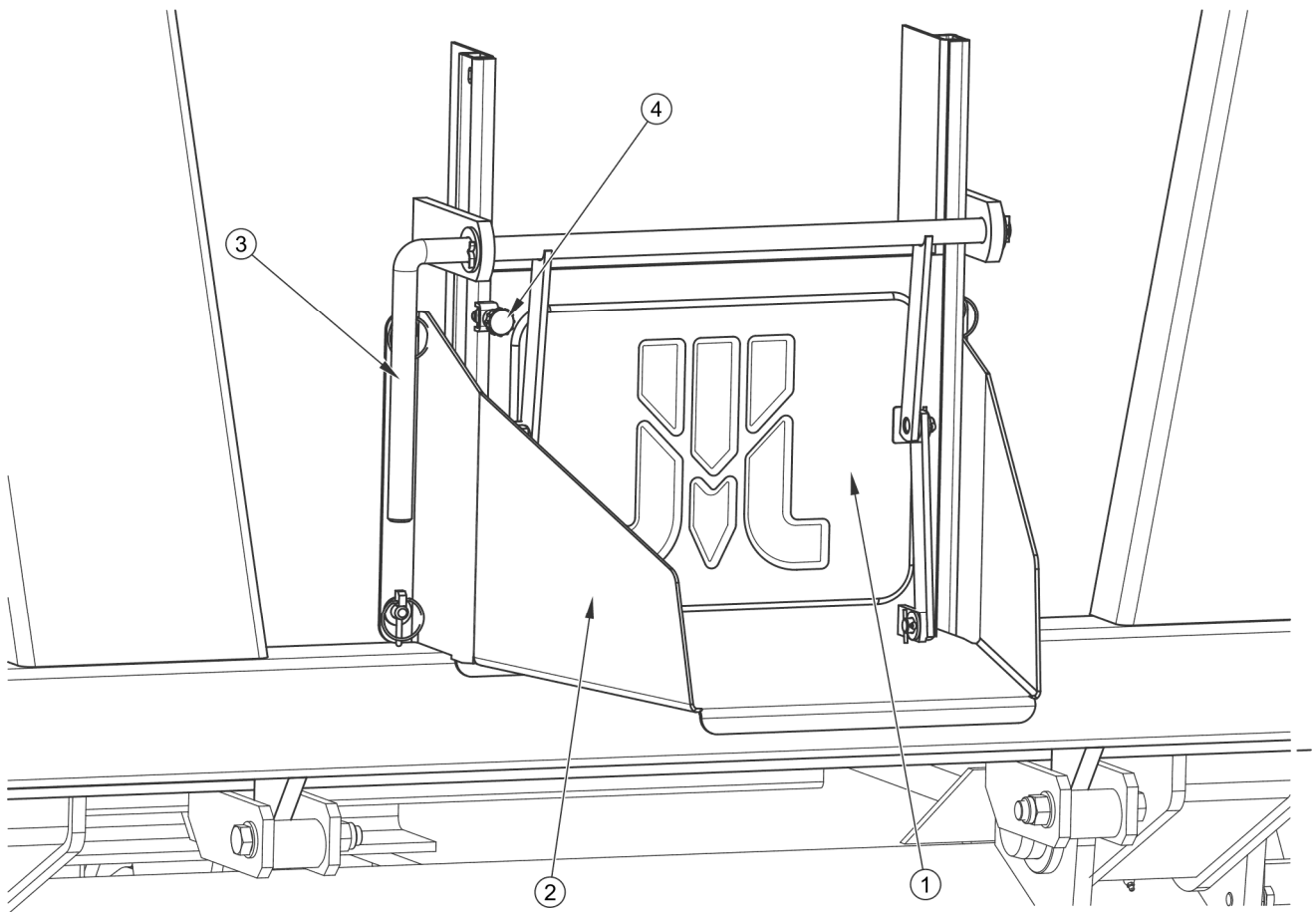

FIGURE 4.2 Chute

(1) chute slide gate, (2) chute, (3) lever, (4) locking bolt

While unloading high-volume materials be especially careful. Do NOT tip load box on uneven or wet ground and move and jerk trailer during unloading. Bulky materials are normally difficult to unload. Therefore, proceed cautiously and patiently. Careless operation of trailer may pose a danger to operators and bystanders can also cause damage to the machine.

4.7 PROPER USE AND MAINTENANCE OF TYRES

- When working on the tyres, chocks or other objects without sharp edges should be placed under the wheels of the trailer to prevent it from rolling. Wheels can be taken off the trailer axle only when the trailer is not loaded.
- Repair work on the wheels or tyres should be carried out by persons trained and entitled to do so. This work should be carried out using appropriate tools.

- Inspect tightness of nuts after the first use of trailer, after the first travel under load and then every 6 months of use or every 25,000 km. In the event of intensive work, check the nut tightening at least every 10,000 km. The inspection should be repeated individually if a wheel has been removed from the wheel axle.
- Regularly check and maintain correct air pressure in tyres according to Operator's Manual (especially if trailer is not used for a longer period).
- Air pressure in tyres should be also checked during the whole day of intensive work. Please note that higher temperatures could raise tyre pressure by as much as 1 bar. At high temperatures and pressure, reduce load or speed.
- Do not release air from warm tyres to adjust the pressure or the tyres will be underinflated when temperatures return to normal.
- valves should be protected with caps to avoid soiling.
- Do not exceed the trailer's maximum design speed.
- When the trailer is operated all day, stop working for a minimum of one hour in the afternoon.
- Take a 30 minute-break for cooling tyres after driving 75 km or after 150 minutes of continuous travel, depending on which occurs first.
- Avoid potholes, sudden manoeuvres or high speeds when turning.

SECTION

5

MAINTENANCE

5.1 PRELIMINARY INFORMATION

When using the trailer, regular inspections of its technical condition are essential and the performance of maintenance procedures, which keep the machine in good technical condition. In connection with this the user of the trailer is obliged to perform all the maintenance and adjustment procedures defined by the Manufacturer.

Repairs during the warranty period may only be performed by authorised service points.

Detailed procedures and extent of activities which the user may perform by himself are described in this section. In the event of unauthorised repairs, changes to factory settings and other actions, which are not regarded as possible for the trailer operator to perform, the user shall invalidate the warranty.

5.2 MAINTENANCE OF BRAKES AND AXLES

5.2.1 PRELIMINARY INFORMATION

Work connected with the repair, change or regeneration of axle and brakes elements should be entrusted to specialist establishments, having the appropriate technology and qualifications for this type of work.

The responsibilities of the user are limited to:

- initial inspection of axle brakes,
- inspection and adjustment of slackness of axle bearings,
- mounting and dismounting wheel, inspection of wheel tightening,
- checking air pressure, evaluating technical condition of wheels and tyres,
- mechanical brakes adjustment,
- replacing the parking brake cable and tension adjustment

Procedures connected with:

- changing grease in axle bearings,
- changing bearings, hub seals,
- changing brake linings, repairing brake,

may be performed by specialist workshops.



DANGER

Do not use the trailer when brake system is out of order.

5.2.2 INITIAL INSPECTION OF AXLE BRAKES

After purchasing trailer, the user is responsible for general checking of brake system of trailer axle.

Inspection procedures

- ➔ Hitch trailer to tractor and place chocks under trailer wheel.
- ➔ Check fixing of cylinder and return springs.
- ➔ Engage and release in turn the main brake and then the trailer parking brake.
 - ⇒ Main brake and parking brake should be engaged and released without great resistance and severity.
- ➔ Check cylinder movement and correct return of piston to start position.
 - ⇒ The help of a second person is required, who shall engage trailer brake.
- ➔ Check if axle elements are in place, (cotter pins in castellated nuts, expansion rings etc.).
- ➔ Check hydraulic cylinders or pneumatic cylinders for tightness - compare sections 5.3.2 and 5.4.2.



Initial inspection of axle brakes must be conducted:

- after first use,
- after first travel with load.

5.2.3 CHECKING BRAKE SHOE LININGS FOR WEAR

Trailer brake shoes should be replaced when the brake lining thickness is less than the minimum specified by the manufacturer.

**ATTENTION**

Minimum thickness of the trailer brake linings is 5 mm.

Check brake shoe linings for wear through the inspection opening (2) – see Figure (5.1).

**Check brake shoe linings for wear:**

- every 3 months,
- if brakes overheat,
- if brake cylinder piston stroke is significantly longer,
- if there are unusual noises from the drum of wheel axle.

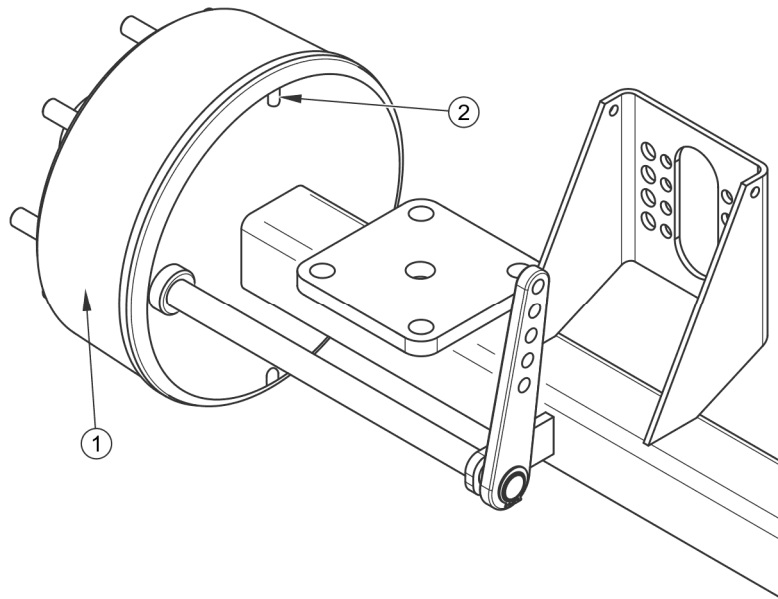

FIGURE 5.1 Checking brake shoe linings

(1) wheel axle drum, (2) brake shoe linings for wear inspection opening

5.2.4 CHECKING WHEEL AXLE BEARINGS FOR SLACKNESS

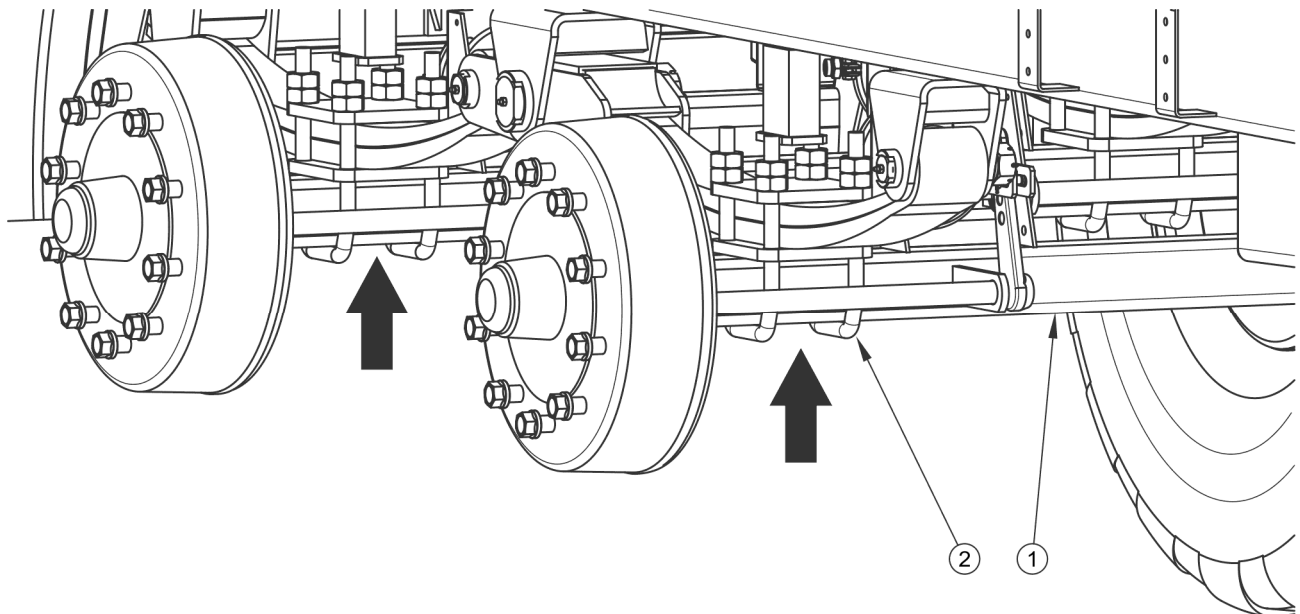

FIGURE 5.2 Lifting jack support point

(1) wheel axle, (2) U bolt

Preparation procedures

- ➔ Hitch trailer to tractor, braking tractor with parking brake.
- ➔ Park tractor and trailer on hard level ground.
 - ⇒ Tractor must be placed to drive forward.
- ➔ Place the wheel chocks under the wheel opposite to the lifted wheel. Ensure that trailer shall not move during inspection.
- ➔ Raise the wheel (opposite to the side where chocks are placed).
 - ⇒ The lifting jack should be placed under the axle between U bolts (2) - figure (5.2) securing axle (1) to shock absorber leaf springs, or as near as possible to leaf spring mounting. Recommended fulcrum is marked with an arrow. Lifting jack must be suitable for the weight of trailer.

Checking wheel axle bearings for slackness

- ➔ Turning the wheel slowly in both directions check that movement is smooth and that the wheel rotates without excessive resistance.
- ➔ Turn the wheel so that it rotates very quickly, check that the bearing does not make any unusual sounds.
- ➔ Moving the wheel try to detect slackness.
 - ⇒ You may use a lever placed under the wheel supporting the other end of the lever on the floor.
- ➔ Repeat the procedure for each wheel individually, remembering that the jack must be on the side opposite to the chocks.

If slackness is felt, adjust bearings. Unusual sounds coming from bearing may be symptoms of excessive wear, dirt or damage. In such an event the bearing, together with sealing ring, should be replaced with new parts, or cleaned and greased again. During inspection of bearings ensure that possibly detected slackness comes from the bearing and not from the suspension system (e.g. slackness of leaf spring pins etc.).

TIP



If hub cover is damaged or missing, contamination and dampness enter the hub, which causes significantly faster wear of bearings and hub seals.

Life of bearings is dependent on working conditions of the trailer, loading, speed of travel and lubrication conditions.

Check condition of hub cover, if necessary replace with a new cover. Inspection of bearing slackness may only be conducted when the trailer is hitched to a tractor and the load box is empty.

Check wheel axle bearings for slackness:



- after travelling the first 1,000 km,
- after intensive use of trailer,
- every six months use or every 25,000 km.

**DANGER**

Before commencing work, the user must read the instructions for lifting jack and adhere to the manufacturer's instructions.

The lifting jack must be stably supported on the ground and so must the axle.

Ensure that trailer shall not move during inspection of axle bearing slackness.

5.2.5 ADJUSTMENT OF PLAY OF WHEEL AXLE BEARINGS**Preparation procedures**

- ➔ Prepare tractor and trailer for adjustment procedures according to description provided in section 5.2.4.

Adjustment of slackness of wheel axle bearing

- ➔ Take off hub cover (1) – figure (5.3).
- ➔ Take out cotter pin (3) securing castellated nut (2).
- ➔ Tighten castellated nut in order to eliminate looseness.
 - ⇒ Wheel should rotate with insignificant resistance.
- ➔ Undo nut (not less than 1/3 rotation) to align the nearest thread groove with the opening in wheel axle pin. Wheel should rotate without excessive resistance.
 - ⇒ The nut must not be excessively tightened. Do not apply excessive pressure because working conditions of the bearings may deteriorate.
- ➔ Secure castellated nut with cotter pin and mount the hub cap.
- ➔ Delicately tap the hub cap with rubber or wooden mallet.

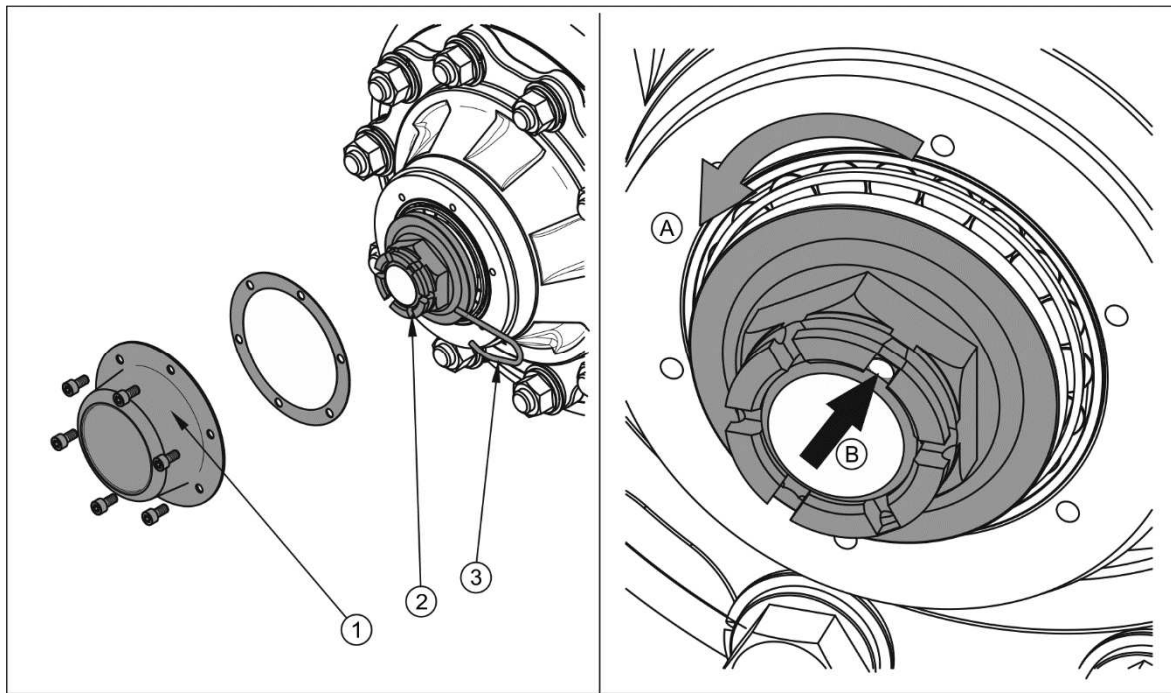

FIGURE 5.3 Adjustment of wheel axle bearings

(1) hub cover, (2) castellated nut, (3) cotter pin

The wheel should turn smoothly without stiffness or detectable resistance not originating from abrasion of brake shoes in brake drum. Adjustment of bearing slackness may only be conducted when the trailer is hitched to tractor and the load box is empty.



TIP

If the wheel is dismantled, bearing looseness is easy to check and adjust.

5.2.6 MOUNTING AND DISMOUNTING WHEEL, INSPECTION OF WHEEL NUT TIGHTENING

Wheel dismantling

- ➔ Immobilise trailer with parking brake.
- ➔ Place the wheel chocks under the wheel opposite to the dismantled wheel.
- ➔ Ensure that trailer shall not move during wheel dismantling.

- ➔ Loosen wheel nuts according to sequence shown in figure (5.4).
- ➔ Place a lifting jack and raise the trailer to a sufficient height so that the wheel to be replaced does not touch the ground.
- ➔ Dismount wheel.

Wheel installation

- ➔ Clean axle pins and nuts of contamination.
 - ⇒ Do not grease thread of nuts and pins.
- ➔ Check condition of pins and nuts, if necessary replace them.
- ➔ Place wheel on hub, tighten nuts so that wheel rim tightly fits the hub.
- ➔ Lower the trailer, tighten nuts according to recommended torque and given sequence.



TIP

Wheel nuts should be tightened using the torque of 450 Nm - M22x1.5 nuts.

Tightening nuts

Nuts should be tightened gradually diagonally, (in several stages, until obtaining the required tightening torque) using a torque spanner. If a torque spanner is not available, one may use an ordinary spanner. The arm of the spanner (L), figure (5.4), should be selected according to the weight of the person (F) tightening the nut. Remember that this method of tightening is not as accurate as the use of a torque spanner.

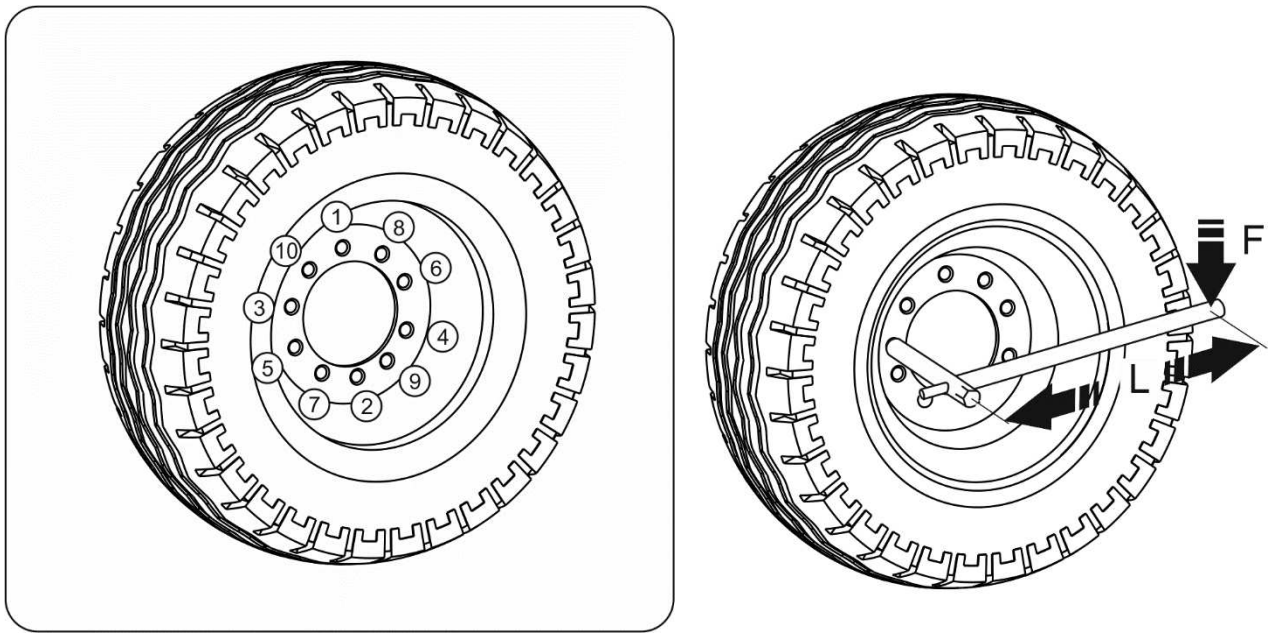

FIGURE 5.4 Sequence of tightening nuts, axles with 10 M22x1.5 pins

(1) - (10) sequence of nut tightening, (L) spanner length, (F) user weight

ATTENTION



Wheel nuts must not be tightened with impact wrench because of danger of exceeding permissible tightening torque, the consequence of which may be breaking the connection thread or breaking off the hub pin.

The greatest precision is achieved using a torque spanner. Before commencing work, ensure that correct tightening torque value is set.

TABLE 5.1 Spanner arm

WHEEL TIGHTENING TORQUE	BODY WEIGHT (F)	ARM LENGTH (L)
[Nm]	[kg]	[m]
450	90	0.5
	80	0.55
	70	0.65
	60	0.75

**Check the wheel nut tightening:**

- after first use,
- after first travel with load,
- after travelling the first 1,000 km,
- every six months of use or every 25,000 km.

In the event of intensive work check the nut tightening at least every 10,000 km. The above actions should be repeated individually if a wheel has been removed from the wheel axle.

5.2.7 CHECKING AIR PRESSURE IN TYRES, EVALUATING TECHNICAL CONDITION OF TYRES AND STEEL WHEELS

Air pressure in tyres should be checked each time after changing a spare wheel and at least once a month. In the event of intensive use, air pressure in tyres should be checked more frequently. During this time, the trailer must be unloaded. Checking should be done before travelling when tyres are not heated, or after an extended period of parking.

**TIP**

Tyre pressure values are specified in information decal, placed on wheel or on upper frame above trailer wheel.

While checking pressure pay attention to technical condition of wheels and tyres. Look carefully at tyre sides and check the condition of tread.

In case of mechanical damage consult the nearest tyre service and check whether the tyre defect requires tyre replacement.

**DANGER**

Damaged tyres or wheels may be the cause of a serious accident.

Wheels should be inspected with regard to distortion, breaking of material, breaking of welds, corrosion, especially in the area of welds and contact with tyre.

Proper technical condition and appropriate maintenance of wheels significantly extends the life of these components and ensures appropriate level of safety to trailer users.



Checking air pressure in tyres and visual inspection of steel wheels:

- every 1 month of use,
- if needed.

5.2.8 ADJUSTMENT OF MECHANICAL BRAKES

During trailer operation drum brake linings are subjected to wear. Piston stroke extends and, after exceeding the limit value, braking force declines.

Adjustment must be made when:

- piston rod stroke amounts to 2/3 of maximum stroke,
- expansion levers are not set in parallel to each other during braking,
- repairs are made to braking system.

Scope of maintenance activities

- ➔ Dismount cylinder fork mounted on expander arm (1).
- ➔ Dismantle expansion ring (3).
- ➔ Mark position of expander arm (1) with regard to the shaft (2).
- ➔ Dismantle arm and set it in the appropriate position.
 - ⇒ in direction (A), if braking is too early,
 - ⇒ in direction (B), if braking is too late.
- ➔ Fit the expansion ring.



The main brake system should be inspected annually and in case of need should be adjusted.

Adjustment should be conducted separately for each wheel. Expander arm (1) should be moved by one notch in chosen direction. If the extent of cylinder action is still incorrect, move the lever again. After proper brake adjustment, at full braking the axle shaft expander should create an angle of 90° with the pneumatic cylinder piston, and the stroke should amount to approximately half the length of the total stroke of the piston. After the brake is released,

expander arms may not be supported on any structural elements, because insufficient withdrawal of a piston ram may cause abrasion of brake shoes in drum and result in overheating the brakes. Expander arms must be positioned in parallel with regard to each other at full braking. If this is not so, adjust the position of the lever, which has the longer stroke.

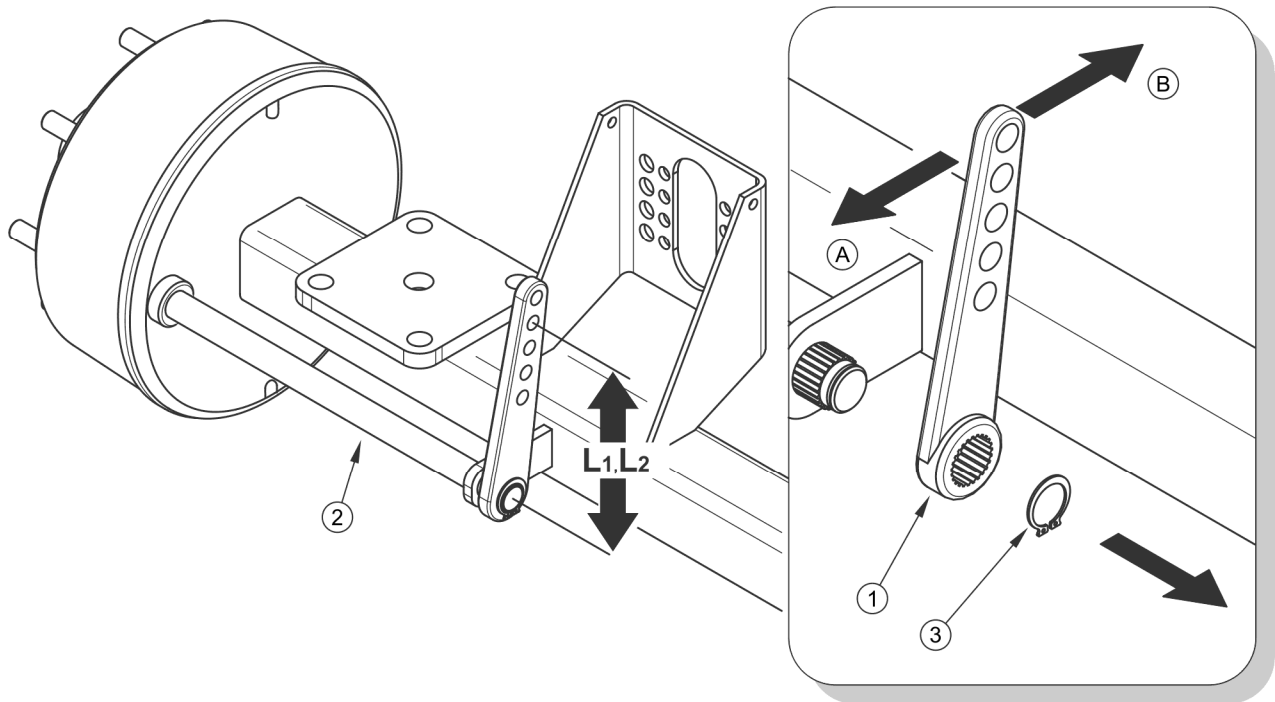

FIGURE 5.5 Adjustment of axle mechanical brakes

(1) expander arm, (2) expander shaft, (3) expansion ring

During dismantling of cylinder fork remember or mark the original setting of the cylinder fork pin (L1 distance - front axle, L2 distance - rear axle). The mounting position is selected by the Manufacturer and must not be changed – see table (5.2).

TABLE 5.2 Position of fork pin in expander arm

TYPE OF BRAKE SYSTEM	PIN POSITION [mm]	
	FRONT AXLE	REAR AXLE
Single conduit pneumatic system	200	150
Double conduit pneumatic system	200	150
Double conduit pneumatic system with ALB.	200	150
Hydraulic brake system	175	175

5.2.9 REPLACEMENT OF PARKING BRAKE CABLE AND ADJUSTMENT OF CABLE TENSION.

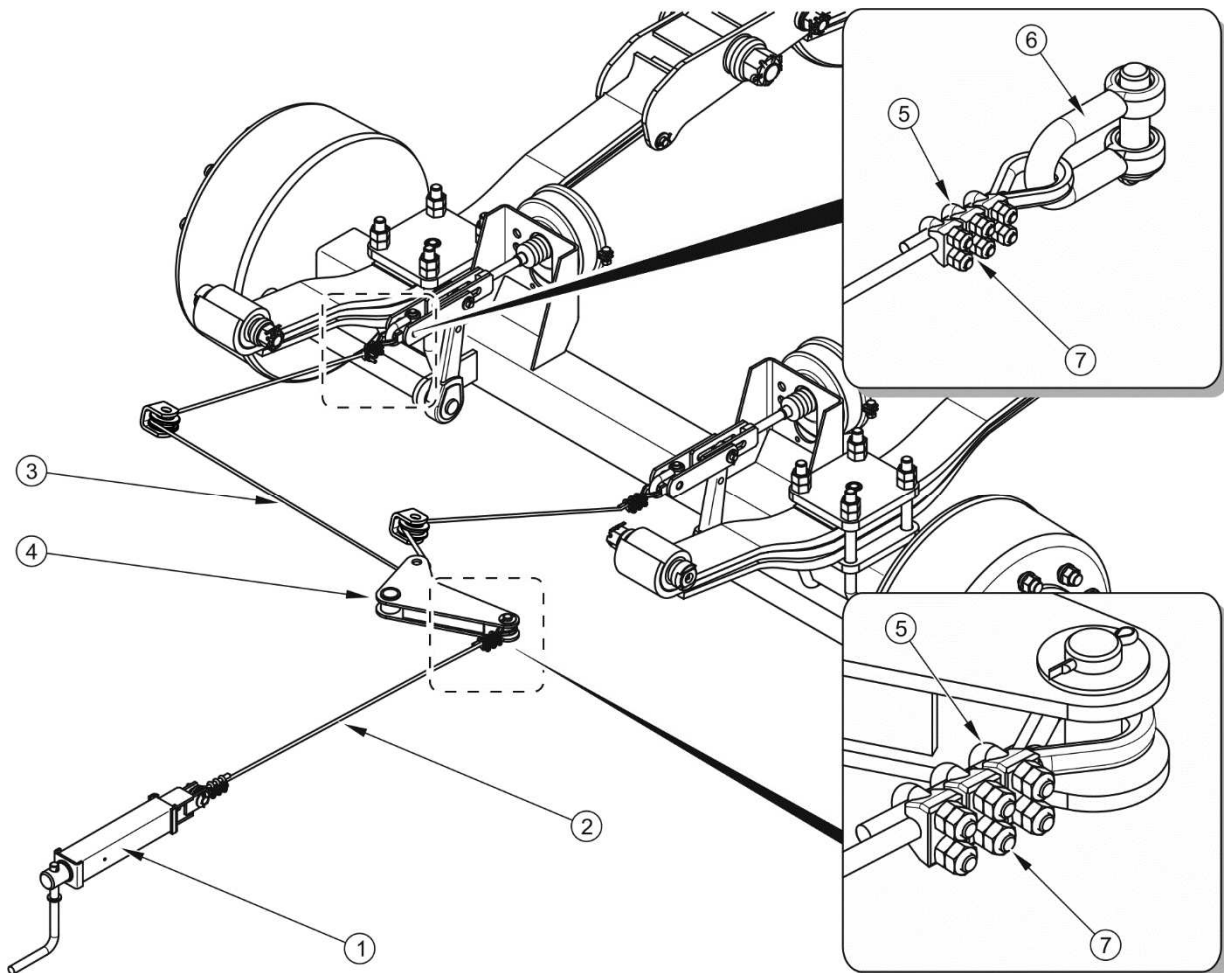

FIGURE 5.6 Adjustment of parking brake cable tension

(1) brake crank mechanism, (2) brake cable I, (3) brake cable II (4) brake lever, (5) U-shaped clamp, (6) shackle (7) clamping nuts

Proper operation of the parking brake is dependent on the effectiveness of the front axle brake and the correct brake cable tension.

Replacing the parking brake cable

- ➔ Hitch trailer to tractor. Park trailer and tractor on level surface.
- ➔ Place securing chocks under one trailer wheel.
- ➔ Fully unscrew the bolt of the brake crank mechanism (2).
- ➔ Loosen the nuts (7) of U-shaped clamps (5).

- ➔ Remove the pins of the lever (4) and crank mechanism (1), remove the shackle (6).
- ➔ Dismantle handbrake cables (2) and (3).
- ➔ Clean parking brake components, lubricate parking brake crank mechanism and pins of cable guide rollers.
- ➔ Install new cables (2) and (3)
 - ⇒ Parking brake cables must be fitted carefully.
 - ⇒ Thimbles and three clamps must be fitted at the ends of the cables.
 - ⇒ Clamps must be tightened. The distances between the clamps may not be less than 15 mm.
 - ⇒ Clamp jaws must be placed on the side of the load bearing cable - see figure (5.7).
 - ⇒ The first clamp should be placed directly on the thimble.

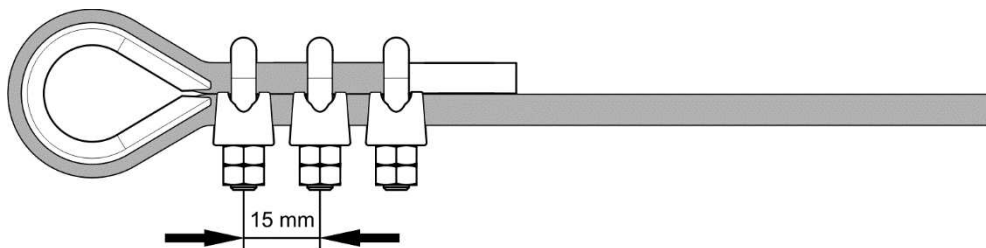

FIGURE 5.7 Installation of steel cable clamps

- ➔ Install bolts and new securing cotter pins.
- ➔ After the first loading of cable, re-check the condition of cable ends, correct if necessary.

Adjustment of parking brake cable tension

- ➔ Hitch trailer to tractor. Park trailer and tractor on level surface.
- ➔ Place securing chocks under one trailer wheel.
- ➔ Unscrew the brake mechanism bolt maximally (1) – figure (5.6), (counterclockwise).
- ➔ Loosen nuts (7) of clamps (5) of handbrake cable (2).

- ➔ Tighten cable and tighten clamps.
 - ⇒ Length of parking brake cable (2) should be so selected that at total release of working and parking brake the cables would be loose and hanging by 1 - 2 cm compared to fully tensioned cables.

Adjustment of parking brake cable tension should be conducted in the event of:

- stretching of cable,
- loosening of parking brake cable clamps
- after adjustment of axle brakes,
- after repairs of axle brake system,
- after repairs of parking brake system.

Before the adjustment, make certain that the axle brake is correctly adjusted and is functioning properly.



Checking and/or adjustment of parking brake:

- every 12 months,
- if needed.

5.3 PNEUMATIC SYSTEM MAINTENANCE

5.3.1 PRELIMINARY INFORMATION

Work connected with repair, replacement or regeneration of system components (brake cylinders, conduits, control valve, braking force regulator, etc.) should be entrusted to specialist establishments, having the appropriate technology and qualifications for this type of work.

The duties of the operator connected with the pneumatic system maintenance include:

- checking tightness and visual inspection of the system,
- cleaning the air filter (filters),
- draining water from air tank,

- cleaning drain valve,
- cleaning and maintaining pneumatic conduit connections,
- replacement of the pneumatic conduit.

**DANGER**

Do not use the trailer when brake system is out of order.

5.3.2 CHECKING AIR TIGHTNESS AND VISUAL INSPECTION OF PNEUMATIC SYSTEM

Checking air tightness of pneumatic system

- ➔ Hitch trailer to tractor.
- ➔ Immobilise tractor and trailer with parking brake. Place chocks under trailer rear wheel.
- ➔ Start tractor in order to supplement air in trailer brake system tank.
 - ⇒ In single conduit systems air pressure should amount to approx. 5.8 bar.
 - ⇒ In double conduit systems air pressure should amount to approx. 8 bar.
- ➔ Turn off tractor engine.
- ➔ Check system components by releasing brake pedal in tractor.
 - ⇒ Pay particular attention to conduit connections and brake cylinders.
- ➔ Repeat the system check with depressed tractor brake pedal.
 - ⇒ The help of a second person is required.

In the event of the appearance of leaks, compressed air will escape at the places of damage, with a characteristic hiss. Lack of system tightness may be detected by covering checked elements with washing fluid or other foaming preparations, which will not react aggressively with the system components. Damaged components should be replaced or repaired. If leaks

appear at connections then tighten the connections. If air continues to escape, replace connection components or seals with new ones.

	<p>Check system tightness:</p> <ul style="list-style-type: none">• after travelling the first 1,000 km,• each time after making repairs or changing system components,• annually.
---	--

Visual inspection of the system

During tightness inspection attention should additionally be given to technical condition and degree of cleanness of the system components. Contact of pneumatic conduit seals etc. with oil, grease, petrol etc. may cause damage and accelerate the ageing process. Bent, permanently deformed, cut or worn conduits should be replaced.

	<p>Visual inspection of the system</p> <ul style="list-style-type: none">• Conduct inspection of system at the same time as when checking tightness.
---	---

	<p>ATTENTION</p> <p>Repair, exchange or regeneration of pneumatic system components may only be performed in a specialised workshop.</p>
---	---

5.3.3 CLEANING THE AIR FILTERS

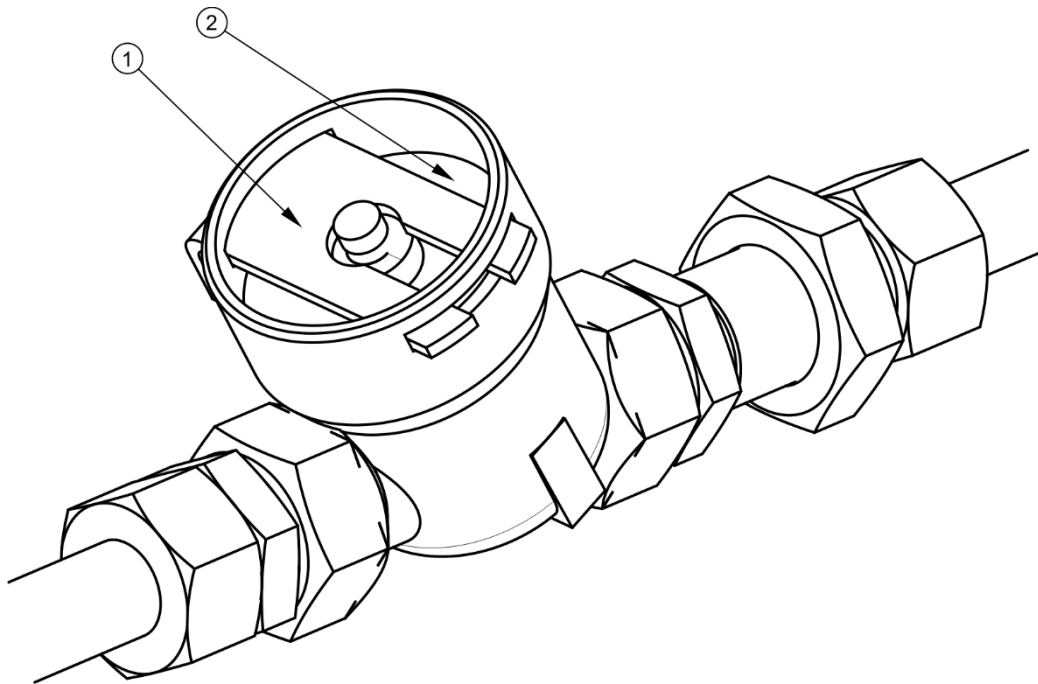

FIGURE 5.8 Air filter

(1) securing slide lock, (2) air filter cover



DANGER

Before proceeding to dismantle filter, reduce pressure in supply conduit. While dismantling the filter slide gate, hold the cover with the other hand. Stand away from filter cover vertical direction.

Depending on trailer working conditions, but not less than once in three months, take out and clean air filter elements, which are located in pneumatic system connection conduits. Filter elements are reusable and are not subject to change unless they are mechanically damaged.

Scope of maintenance activities

- ➔ Reduce pressure in supply conduit.
 - ⇒ Reduction of pressure in conduit may be achieved by pressing the head of the pneumatic connection until resistance is felt.
- ➔ Slide out securing slide lock (1) – figure (5.8).

- ⇒ Hold the filter cover (2) with the other hand. After removing slide lock, the cover is pushed off by the spring located in the filter housing.
- ➔ The filter element and the filter body should be carefully cleaned and blown through with compressed air. Assembly should be done in reverse order.

	Cleaning the air filter (filters): <ul style="list-style-type: none">• every 3 months of use,
---	--

5.3.4 DRAINING WATER FROM AIR TANK

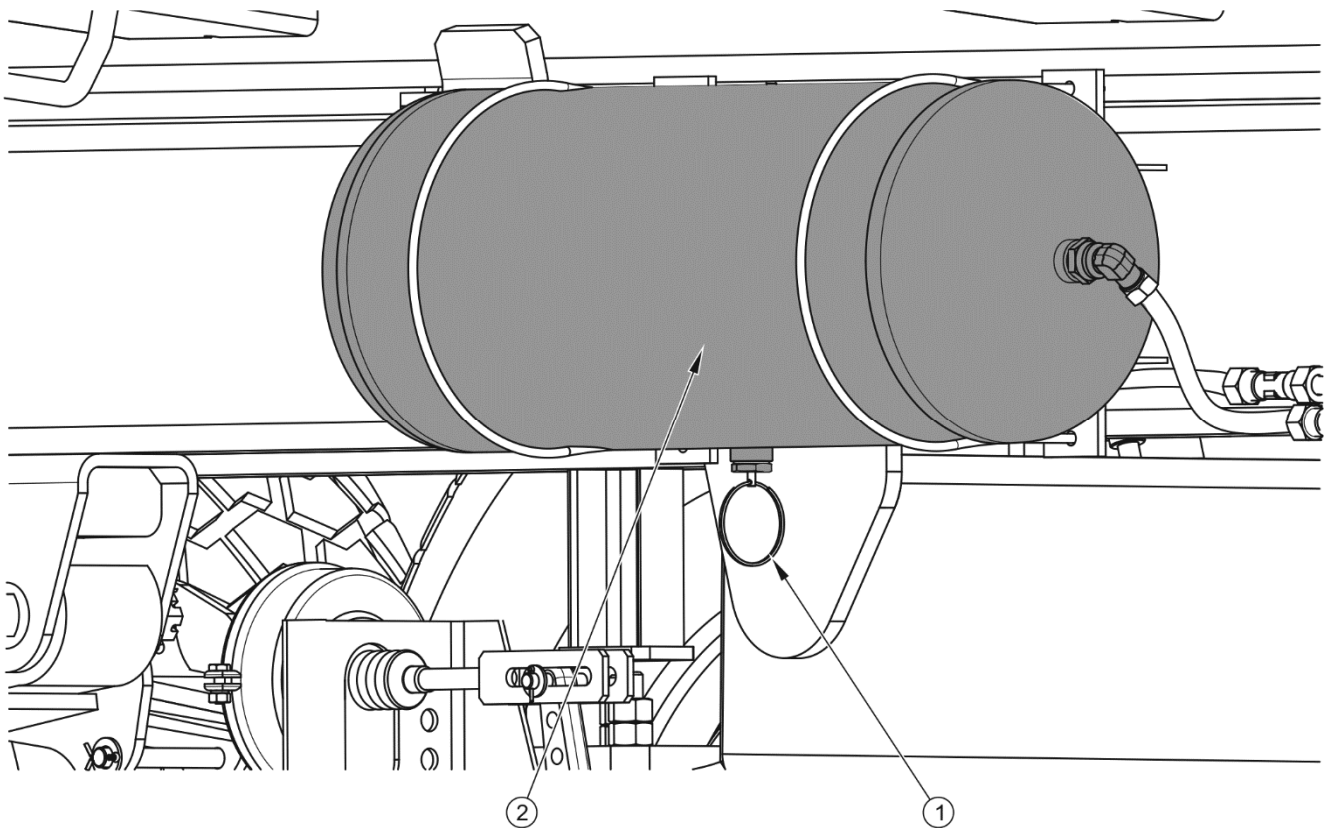

FIGURE 5.9 Draining water from air tank

(1) drain valve, (2) air tank

Scope of maintenance activities

- ➔ Tilt drain valve stem (1) located in the lower part of tank (2).

- ⇒ The compressed air in the tank causes the removal of water to the exterior.
- ➔ Released valve stem should automatically close and stop flow of air from the tank.
 - ⇒ If the valve stem resists returning to its position, then the whole drain valve must be unscrewed and cleaned or replaced (if it is damaged) - see section 5.3.5.

**Draining water from air tank:**

- after each week of use.

5.3.5 CLEANING THE DRAIN VALVE

**DANGER**

Release air from the air tank before dismantling drain valve.

Scope of maintenance activities

- ➔ Completely reduce pressure in air tank.
 - ⇒ Reduction of pressure in tank is achieved by tilting the drain valve stem.
- ➔ Unscrew valve.
- ➔ Clean the valve, blow it with compressed air.
- ➔ Change copper seal.
- ➔ Screw in valve, fill tank with air and check tank tightness.

**Cleaning the valve:**

- every 12 months (before winter period).

5.3.6 CLEANING AND MAINTAINING PNEUMATIC CONDUIT CONNECTIONS AND PNEUMATIC SOCKETS



DANGER

Unreliable and dirty trailer connections may cause unreliability and faulty functioning of braking system.

Damaged connection body or socket for connecting the second trailer should be replaced. In the event of damage to cover or seal, change these elements for new reliable elements. Contact of pneumatic connector seals with oils, grease, petrol etc. may cause damage and accelerate ageing process.

If the trailer is unhitched from the tractor, connections should be protected by covers or placed in their designated sockets. Before the winter, it is recommended to preserve the seal with special preparations (e.g. silicon grease for rubber elements).

Each time before hitching the machine, inspect technical condition and cleanness of connectors and sockets in tractor. If necessary, clean or repair tractor sockets.



Inspecting trailer connections:

- connection should be inspected every time before connecting trailer to tractor or second trailer.

5.3.7 REPLACEMENT OF PNEUMATIC CONDUIT

Pneumatic conduits should be replaced when permanently deformed, cut or frayed.

Scope of maintenance activities

- ➔ Release all pressure from the system.
 - ⇒ Reduction of pressure is achieved by tilting the drain valve mandrel.
- ➔ Remove the pneumatic conduit by loosening the nut (2).
- ➔ Fit the new conduit.
 - ⇒ The interior of the conduit should be clean.

- ⇒ The ends of the pneumatic conduit (1) must be cut exactly at right angles.
 - ⇒ Clamping ring (3) should be fitted according to figure (5.10).
 - ⇒ Reinforcing sleeve (4) of the conduit must be thoroughly depressed.
- ➔ Check tightness of connections in accordance with Chapter (5.3.2).

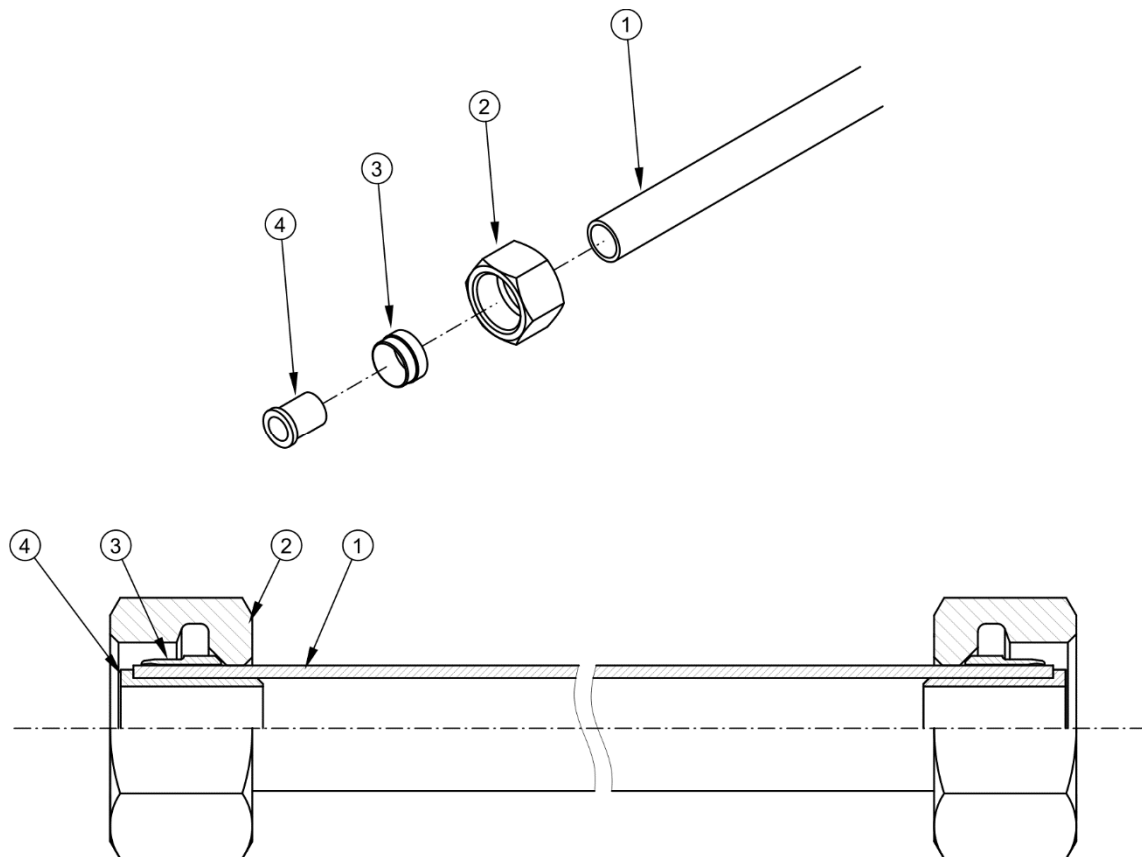

FIGURE 5.10 Installation of pneumatic conduit

(1) pneumatic conduit, (2) connecting nut (3) clamping ring, (4) reinforcing sleeve

5.4 HYDRAULIC SYSTEM MAINTENANCE

5.4.1 PRELIMINARY INFORMATION

Work connected with the repair, change or regeneration of hydraulic system components (hydraulic cylinders, valves etc.) should be entrusted to specialist establishments, having the appropriate technology and qualifications for this type of work.

The duties of the operator connected with the hydraulic system maintenance include:

- checking tightness and visual inspection of the system,
- checking technical condition of hydraulic connections.

DANGER



- Do NOT tip trailer with unreliable hydraulic tipping system.**
- Do not use the trailer if the support hydraulic system is out of order.**
- Do NOT use the trailer if hydraulic brake system is unreliable.**
- Do NOT use the trailer if hydraulic tailgate system is unreliable.**

5.4.2 CHECKING HYDRAULIC SYSTEM TIGHTNESS

Scope of maintenance activities

- ➔ Hitch trailer to tractor.
- ➔ Connect all hydraulic system conduits according to maintenance instructions.
- ➔ Clean connections and cylinders (tipping cylinder, hydraulic tailgate cylinders and possibly hydraulic brake cylinders and axle turning interlock cylinders).
- ➔ Conduct test tipping of load box backwards.
- ➔ Open and close the tailgate several times.
- ➔ Press tractor brake pedal several times.
 - ⇒ Only if the trailer is equipped with hydraulic brake system.
- ➔ Check hydraulic cylinders and conduits for tightness.

If oil leak is detected on hydraulic cylinder body, ascertain origin of leak. Inspect seals when hydraulic cylinder is completely extended. Minimum leaks are permissible with symptoms of "sweating", however in the event of noticing leaks in the form of "droplets" stop using the trailer until faults are remedied. If unreliability is evident in brake cylinders, do NOT use trailer with damaged system until faults are remedied.



Checking tightness:

- after the first week of use,
- every 12 months of use.

5.4.3 CHECKING TECHNICAL CONDITION OF HYDRAULIC COUPLERS AND SOCKETS.

Hydraulic connections and sockets designed for connection with second trailer must be in good working condition and kept clean. Each time before connecting, check if sockets in tractor or connections of second trailer are maintained in good working condition. Tractor and trailer hydraulic systems are sensitive to the presence of permanent contamination, which may cause damage to precision system components (jamming of hydraulic valves, scratching of cylinder surfaces etc.)



Inspection of hydraulic couplers and sockets:

- each time before connecting trailer to tractor or before connecting the second trailer.

5.4.4 REPLACEMENT OF HYDRAULIC CONDUITS

Rubber hydraulic conduits must be replaced every 4 years regardless of their technical condition. This should be done in specialised workshops.



Replacement of hydraulic conduits:

- every 4 years.

5.5 MAINTENANCE OF ELECTRICAL SYSTEM AND WARNING ELEMENTS

5.5.1 PRELIMINARY INFORMATION

Work connected with the repair, change or regeneration of electrical system components should be entrusted to specialist establishments, having the appropriate technology and qualifications for this type of work.

The responsibilities of the user are limited to:

- technical inspection of electrical system and reflectors,

- changing bulbs



ATTENTION

Do NOT travel with out of order lighting system. Damaged lamp lenses, and burned-out bulbs must be replaced immediately before travelling. Lost or damaged reflectors must be replaced.

Scope of maintenance activities

- ➔ Connect trailer to tractor with appropriate connection lead.
 - ⇒ Check if the connection lead is reliable. Check connection sockets in tractor and trailer.
- ➔ Check completeness and technical condition of trailer lights.
- ➔ Check completeness of all reflectors.
- ➔ Check correct mounting of the slow-moving vehicle warning sign holder.
- ➔ Before driving on to public road, check that the tractor is equipped with a warning reflective triangle.



Checking technical condition of electrical system:

- each time while connecting the trailer.



TIP

Before driving off, make certain that all lamps and reflectors are clean.

5.5.2 REPLACEMENT OF BULBS

Compatible bulbs are shown in table (5.3). All light lenses are secured by screws and it is not necessary to dismantle whole lamp or trailer subassemblies.

TABLE 5.3 List of bulbs

LAMP	LAMP TYPE	BULB / QUANTITY IN 1 LAMP	NUMBER OF LAMPS
Rear left lamp assembly	WE 549L	R10W / 1 pc P21W / 2 pcs	1
Rear right lamp assembly	WE 549P	R10W / 1 pc P21W / 2 pcs	1
Licence plate light	LT-120	C5W – 1 pc	2
Front parking light	LO-110PP	C5W / 1 pc	2
Rear clearance lamp	127 021 00 00	R5W / 1 pc	2

5.6 TRAILER LUBRICATION

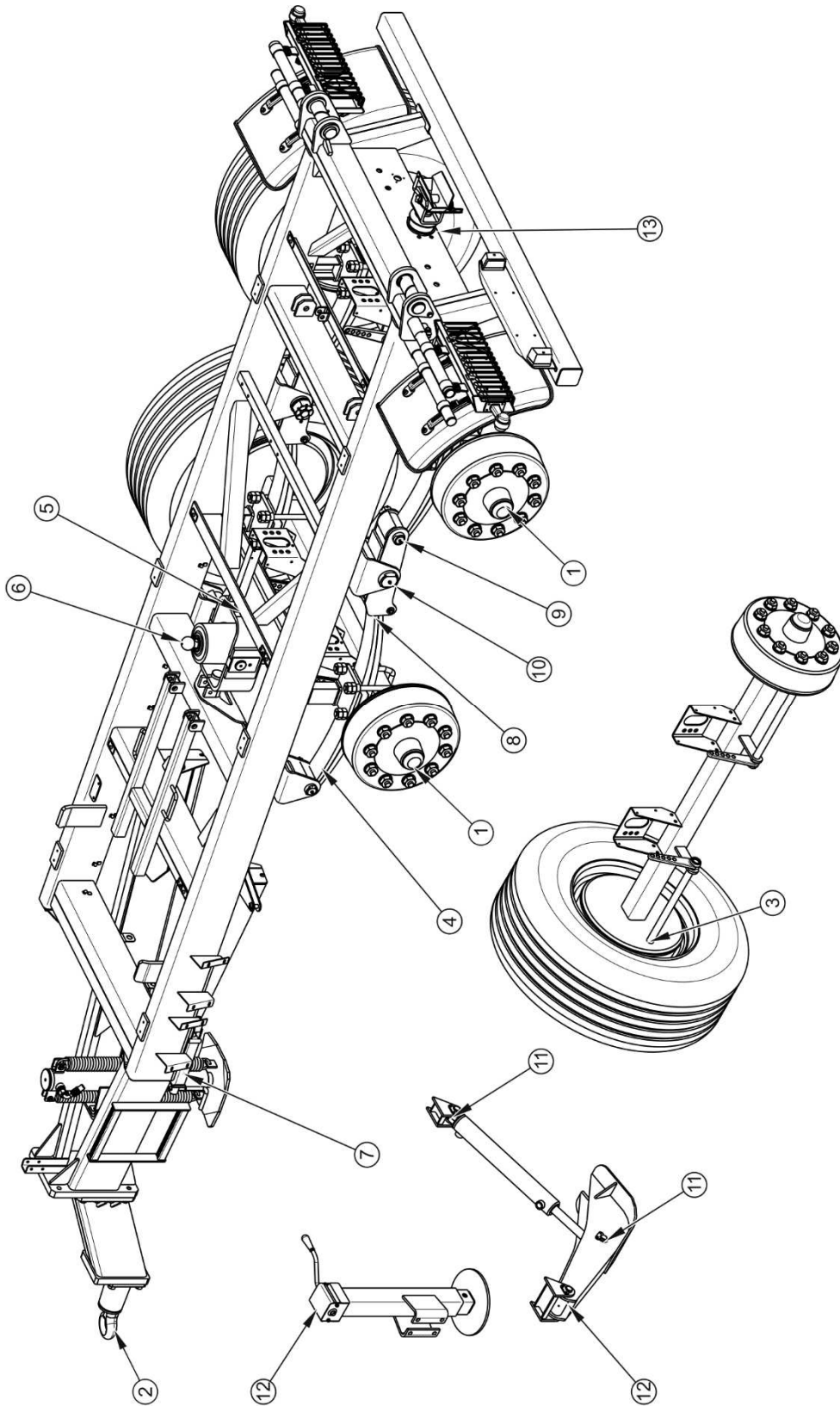

FIGURE 5.11 Trailer's lubrication points

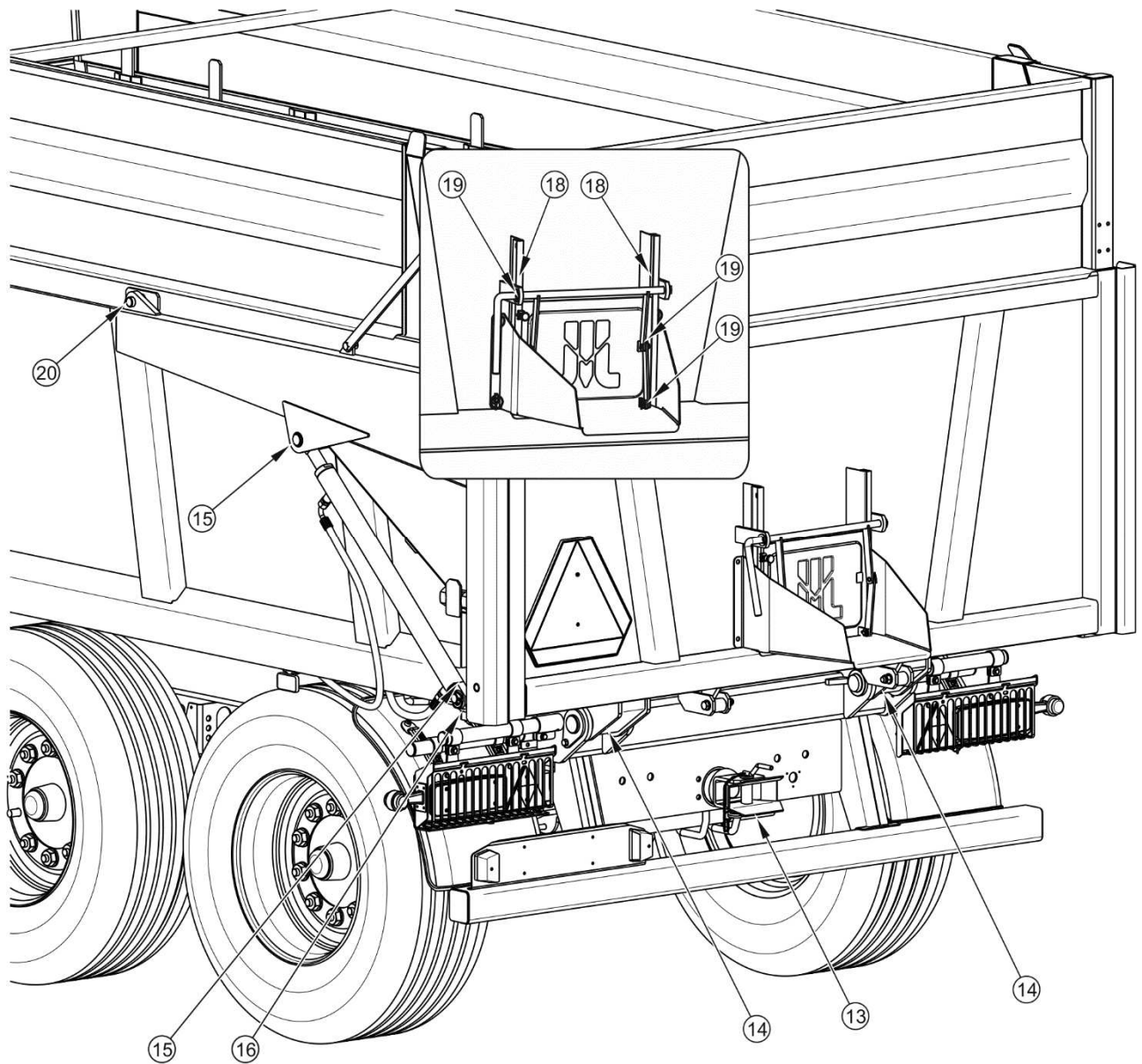

FIGURE 5.12 Trailer's lubrication points

TABLE 5.4 Trailer lubrication schedule

ITEM	LUBRICATION POINT	NUMBER OF LUBRICATION POINTS	TYPE OF GREASE	FREQUENCY
1	Wheel hub bearing	4	A	24M

ITEM	LUBRICATION POINT	NUMBER OF LUBRICATION POINTS	TYPE OF GREASE	FREQUENCY
2	Drawbar eye	1	B	14D
3	Expander shaft sleeve	4	A	3M
4	Parabolic leaf springs	4	C	6M
5	Socket for installation of tipping ram and cylinder suspension	4	B	1M
6	Tipping cylinder ball bearing	1	B	3M
7	Parking brake mechanism	1	A	6M
8	Leaf spring sliding surface	4	A	3M
9	Leaf spring pin	4	A	3M
10	Rocker arm pin	2	B	3M
11	Shear type drawbar support cylinder bearing	2	A	3M
12	Shear type drawbar support pin	1	A	3M
13	Rear hitch mechanism	1	A	3M
14	Tipping pin	2	B	3M
15	Tailgate cylinder bearing	4	A	3M
16	Securing hook pin	2	A	3M

ITEM	LUBRICATION POINT	NUMBER OF LUBRICATION POINTS	TYPE OF GREASE	FREQUENCY
17	Tailgate wing securing pin	2	A	3M
18	Slide gate guide	2	D	1M
19	Chute string pin	6	D	1M
20	Tailgate wing securing pin	2	A	3M

Lubrication periods – M months, D – days, ⁽¹⁾ – not shown in figure

TABLE 5.5 Recommended lubricants

MARKING ACCORDING TO TAB. (5.4)	DESCRIPTION
A	machine general-purpose grease (lithium, calcium grease),
B	Grease for heavily loaded elements with addition of MoS ₂ or graphite
C	anticorrosion preparation in aerosol
D	ordinary machine oil, silicon grease in aerosol

Trailer lubrication should be performed with the aid of a manually or foot operated grease gun, filled with recommended grease. Before commencing work insofar as is possible remove old grease and other contamination. Remove and wipe off excess oil or grease.

Before beginning to grease leaf springs remove contamination, wash with water and leave to dry. Do not use pressure washers, which may cause moisture penetration between individual leaf spring plates. Absorber plates should be lubricated using an agent having both anticorrosion and lubricating properties, it is recommended to apply on outer leaf spring surfaces very thin layer of lithium or lime alkali grease. For this purpose, silicone aerosol preparation (for lubricating guides, locks etc. - see table) can be also used. Sliding surface of

leaf spring and leaf spring pin should be lubricated according to recommendations contained in table (5.4).

Parts to be lubricated with machine oil should be wiped with dry clean cloth and then a small quantity of oil should be applied to their surfaces (using oil can or brush). Wipe off excess oil.

Change of grease in hub bearings should be entrusted to specialised service points, equipped with the appropriate tools. According to the recommendations of the axle Manufacturer, dismantle the entire hub, remove the bearing and individual sealing rings. After careful washing and inspection, mount lubricated elements. If necessary, bearing and seals should be replaced with new parts. Lubrication of axle bearings shall be performed at least once in 2 years or every 50,000 km. In the event of intensive use, lubrication should be performed more frequently.

Empty grease or oil containers should be disposed of according to the recommendations of the lubricant Manufacturer.



During trailer operation, the user is obliged to observe lubrication instructions according to attached lubrication schedule.

5.7 CONSUMABLES

5.7.1 HYDRAULIC OIL

Always adhere to the principle that the oil in the trailer hydraulic system and in the tractor hydraulic system are of the same type. In the event of application of different types of oil make certain that both hydraulic substances may be mixed together. Application of different oil types may cause damage to trailer or tractor. In a new machine, the hydraulic system is filled with L HL32 Lotos hydraulic oil.

If it is necessary to change hydraulic oil for another oil, check the recommendations of the oil Manufacturer very carefully. If it is recommended to flush the system with the appropriate preparation, then comply with these recommendations. Attention should be given, so that chemical substances used for this purpose do not damage the materials of the hydraulic system. During normal trailer use change of hydraulic oil is not necessary, but if required, this operation should be entrusted to a specialist service point.

TABLE 5.6 L-HL 32 Lotos hydraulic oil characteristics

ITEM	NAME	UNIT	VALUE
1	ISO 3448VG viscosity classification	-	32
2	Kinematic viscosity at 40 ⁰ C	mm ² /s	28.8 – 35.2
3	ISO 6743/99 quality classification	-	HL
4	DIN 51502 quality classification	-	HL
5	Flash-point	C	230

Because of its composition the oil applied is not classified as a dangerous substance, however long-term action on the skin or eyes may cause irritation. In the event of contact of oil with skin wash the place of contact with water and soap. Do NOT apply organic solvents (petrol, kerosene). Contaminated clothing should be changed to prevent access of oil to skin. In the event of contact of oil with eye, rinse with large quantity of water and in the event of the occurrence of irritation consult a doctor. Hydraulic oil in normal conditions is not harmful to the respiratory tract. A hazard only occurs when oil is strongly atomised (oil vapour), or in the case of fire during which toxic compounds may be released. Oil fires should be quenched with the use of carbon dioxide, foam or steam extinguishers. Do not use water to quench oil fires.

5.7.2 LUBRICANTS

For heavily loaded parts it is recommended to apply lithium greases with addition of molybdenum disulphide (MOS₂) or graphite. In the case of less loaded sub-assemblies the application of general purpose machine greases is recommended, which contain anticorrosion additives and have significant resistance to being washed away by water. Aerosol preparations (silicon greases and anticorrosive-lubricating substances) should have similar characteristics.

Before using the grease, read its information leaflet. Particularly relevant are safety rules and handling procedures for a given lubricant as well as waste disposal procedure (used containers, contaminated rags etc.). Information leaflet (material safety data sheet) should be kept together with grease.

5.8 CLEANING THE TRAILER

Trailer should be cleaned depending on requirements and before longer idle periods (e.g. before winter period). Before using pressure washer the user is obliged to acquaint himself with the operating principles and recommendations concerning safe use of this equipment.

Trailer cleaning guidelines

- Before cleaning the trailer open the tailgate. Carefully clean load remains from the load box (sweep out or blow out with compressed air), especially where tailgate and extensions join together.
- To clean the trailer, use only clean running water or water with a cleaning detergent additive with neutral pH.
- Using pressure washer increases washing effectiveness, but particular care must be taken during work. During washing, washer nozzle may not be closer than 50 cm from the surface being cleaned.
- Water temperature should not exceed 55°C.
- Do not direct water stream directly at system and equipment elements of trailer i.e. control valve, braking force regulator, brake cylinders, hydraulic cylinders, pneumatic, electric and hydraulic plugs, lights, electrical connections, information and warning decals, identification plates, conduit connections, spring leaves and lubrication points etc. Great water jet pressure may cause mechanical damage to these elements.
- For cleaning and maintenance of plastic coated surfaces it is recommended to use clean water or special preparations designed for this purpose.
- Do not apply organic solvents, preparations of unknown origin or other substances, which may cause damage to lacquered, rubber or plastic surfaces. In the event of doubt it is recommended to make a test on an unseen surface area.
- Surfaces smeared with oil or grease should be cleaned by application of benzene or other degreasing agents and then washed with clean water with added detergent. Comply with recommendations of the Manufacturer of cleaning agents.

**DANGER**

Carefully read the instructions for application of detergents and maintenance preparations.

While washing with detergents wear appropriate protective clothing and goggles protecting against splashing.

- Detergents should be kept in original containers, optionally in replacement containers, but very clearly marked. Preparations may not be stored in food and drink containers.
- Ensure cleanliness of elastic conduits and seals. The plastic from which these elements are made may be susceptible to organic substances and some detergents. As a result of long-term reaction of some substances, the ageing process may be accelerated and risk of damage increased. Rubber elements should be maintained with the aid of special preparations after previous thorough washing.
- After completed washing wait until the trailer is dry and then grease all inspection points according to recommendations. Remove excess oil or grease with a dry cloth.
- Observe environmental protection principles and wash trailer in a place designed for this purpose.
- Washing and drying of the trailer must take place at temperatures above 0°C.
- After washing and drying, trailer should be greased at all control points regardless of previous date of lubrication.

5.9 STORAGE

- Trailer should be kept in closed or roofed building.
- If the machine will not be used for a long time, it is essential to protect it from adverse weather, especially rust and accelerated tyre deterioration. During this time the machine must be unloaded. Trailer should be very carefully washed and dried.

- Corroded places should be cleaned of rust, degreased and protected using undercoat paint and then painted with surface paint according to colour scheme.
- In the event of a prolonged work stoppage, it is essential to lubricate all components regardless of the date of the last lubrication.
- Wheel rims and tyres should be carefully washed and dried. During longer storage of unused trailer it is recommended that every 2 to 3 weeks the machine may be moved a bit so that the place of contact of tyres with ground is changed. The tyres will not be deformed and maintain proper geometry. Also, air pressure in tyres should be inspected from time to time and, if necessary, pressure should be increased to the appropriate value.
- If trailer is equipped with tarpaulin cover, it should be carefully washed and dried. If possible, clean tarpaulin cover should be stored unrolled, otherwise carefully roll it without folding and breaking the material.

5.10 TIGHTENING TORQUE FOR NUT AND BOLT CONNECTIONS

Unless other tightening parameters are given, during maintenance-repair work apply appropriate torque to tighten nut and bolt connections. Recommended tightening torque for the most frequently used nut and bolt connections are given in table below. Given values apply to non-lubricated steel bolts.

TABLE 5.7 Tightening torque for nut and bolt connections

METRIC THREAD	5.8 ⁽¹⁾	8.8 ⁽¹⁾	10.9 ⁽¹⁾
	Md [Nm]		
M10	37	49	72
M12	64	85	125
M14	100	135	200
M16	160	210	310
M20	300	425	610
M24	530	730	1 050
M27	820	1 150	1 650
M30	1 050	1,450	2,100

⁽¹⁾ – strength class according to DIN ISO 898 standard

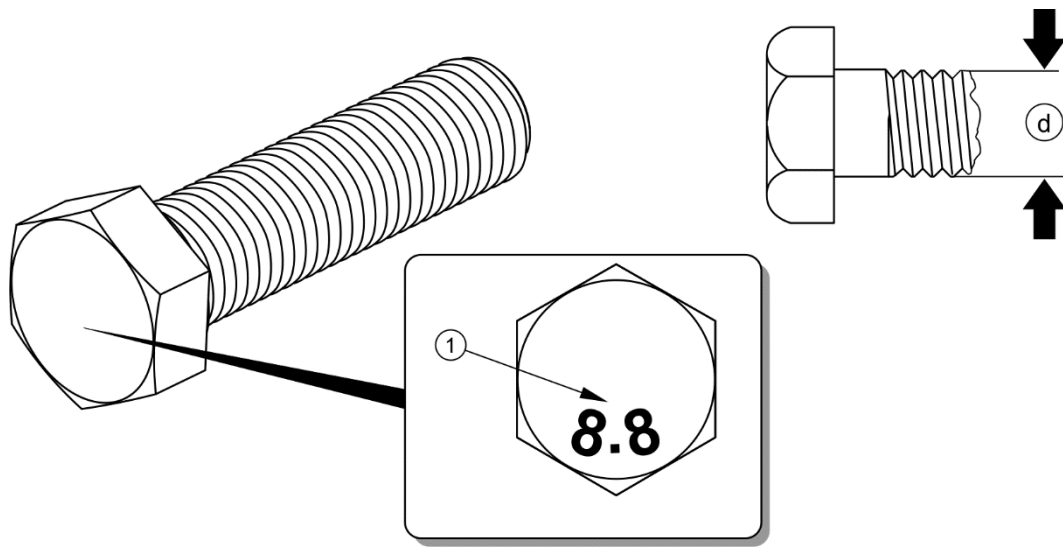

FIGURE 5.13 Bolt with metric thread

(1) strength class, (d) thread diameter

Hydraulic conduits should be tightened using torque of 50 – 70 Nm.

5.11 INSTALLATION AND DISASSEMBLY OF THE FRAME AND TARPAULIN COVER

Tarpaulin cover can only be used together with the frame. The assembly of wall extensions should be carried out with the use of appropriate platforms, ladders, ramps or other stable raised surfaces. Particular care should be taken, holding onto the trailer with one hand. Work should be done with the help of another person

The frame structure comprises front apex (1), centre apex (2), rear apex (3), as well as connecting pipe (4) – figure (5.14).

Assembly of frame and tarpaulin

- ➔ Attach front apex (1) to the front wall extension.
- ➔ Attach rear apex (3) to the rear wall extension.
- ➔ Attach centre apex (2) to lateral wall extensions.
- ➔ Screw the connecting pipe (4) to the front and centre apexes
- ➔ Install limiters (5) to side wall extensions on the right side of the load box.

- ➔ Place tarpaulin cover (6) so that it rests on the limiters (5) on the right side.
 - ⇒ The tarpaulin cover should be folded so that it is possible to unroll it without unnecessary relocation of material.
- ➔ Install tarpaulin cover fastening straps (7) to the holders riveted to the right side of the load box.
- ➔ Unroll tarpaulin cover and secure it with fastening straps (7) to holders (8) located on the left side of the trailer.
- ➔ Tighten tarpaulin cover and secure with fastening straps (7) the front and rear part of the tarpaulin cover.

Disassembly of the frame and tarpaulin cover should be performed in reverse order.



DANGER

Assembly and disassembly of the frame should be carried out with the use of appropriate platforms, ladders or when standing on a ramp. These tools must be in good condition to fully protect the persons working on them against falling. Work should be performed by at least two persons. Exercise particular caution.

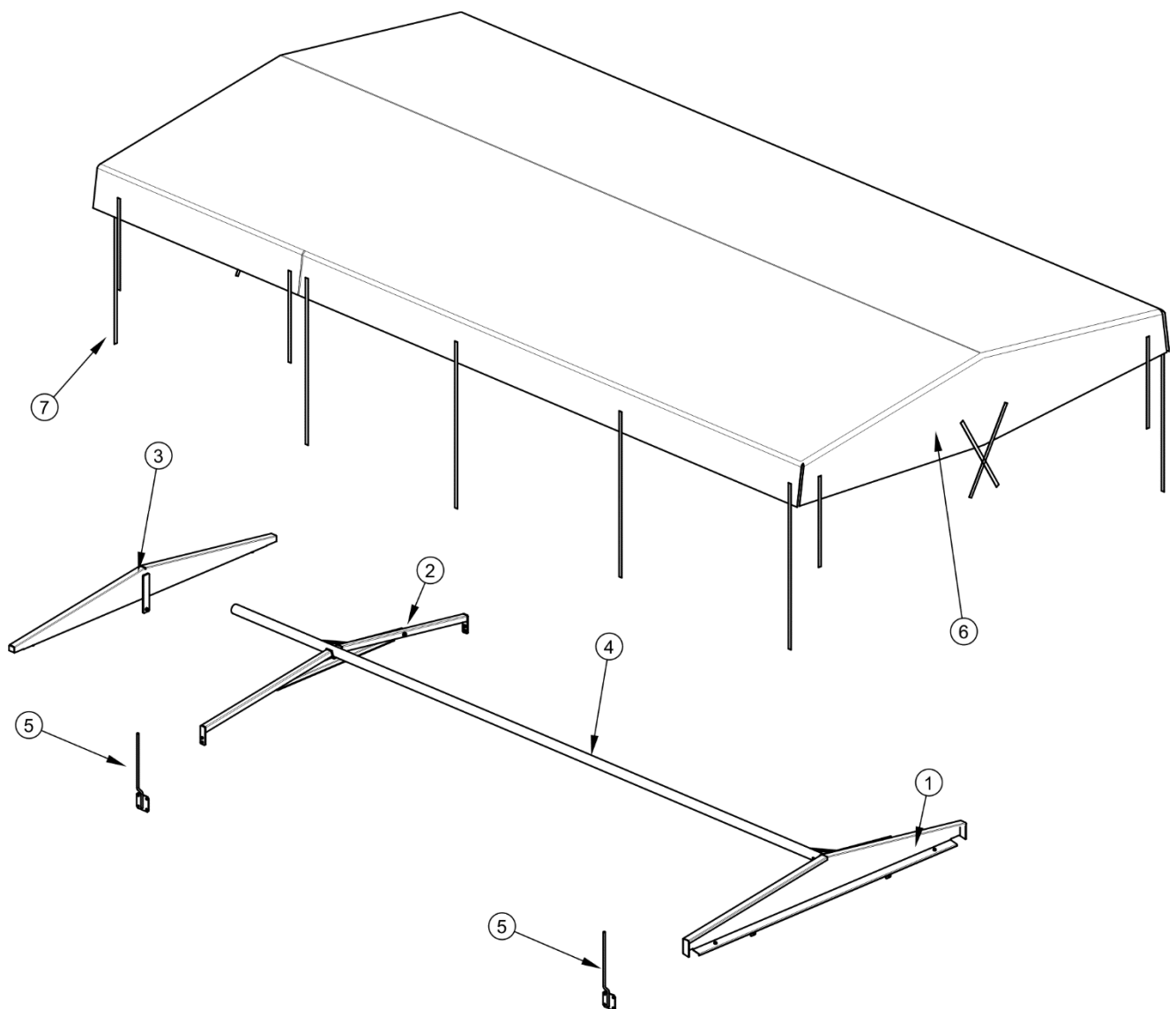

FIGURE 5.14 Frame with tarpaulin cover

(1) front apex, (2) centre apex, (3) rear apex (4) connecting pipe, (5) limiter, (6) tarpaulin cover, (7) fastening strap

5.12 ADJUSTMENT OF DRAWBAR POSITION

Position of trailer drawbar is chosen depending on the type of agricultural tractor hitch to be used to hitch the trailer. If possible, we recommend adjusting the tractor hitch so that the trailer drawbar is positioned horizontally while driving on a flat terrain.

The transition from lower to the upper hitch and vice versa is achieved by reversing the drawbar (1) by 180 degrees and mounting it to the faceplate (2).

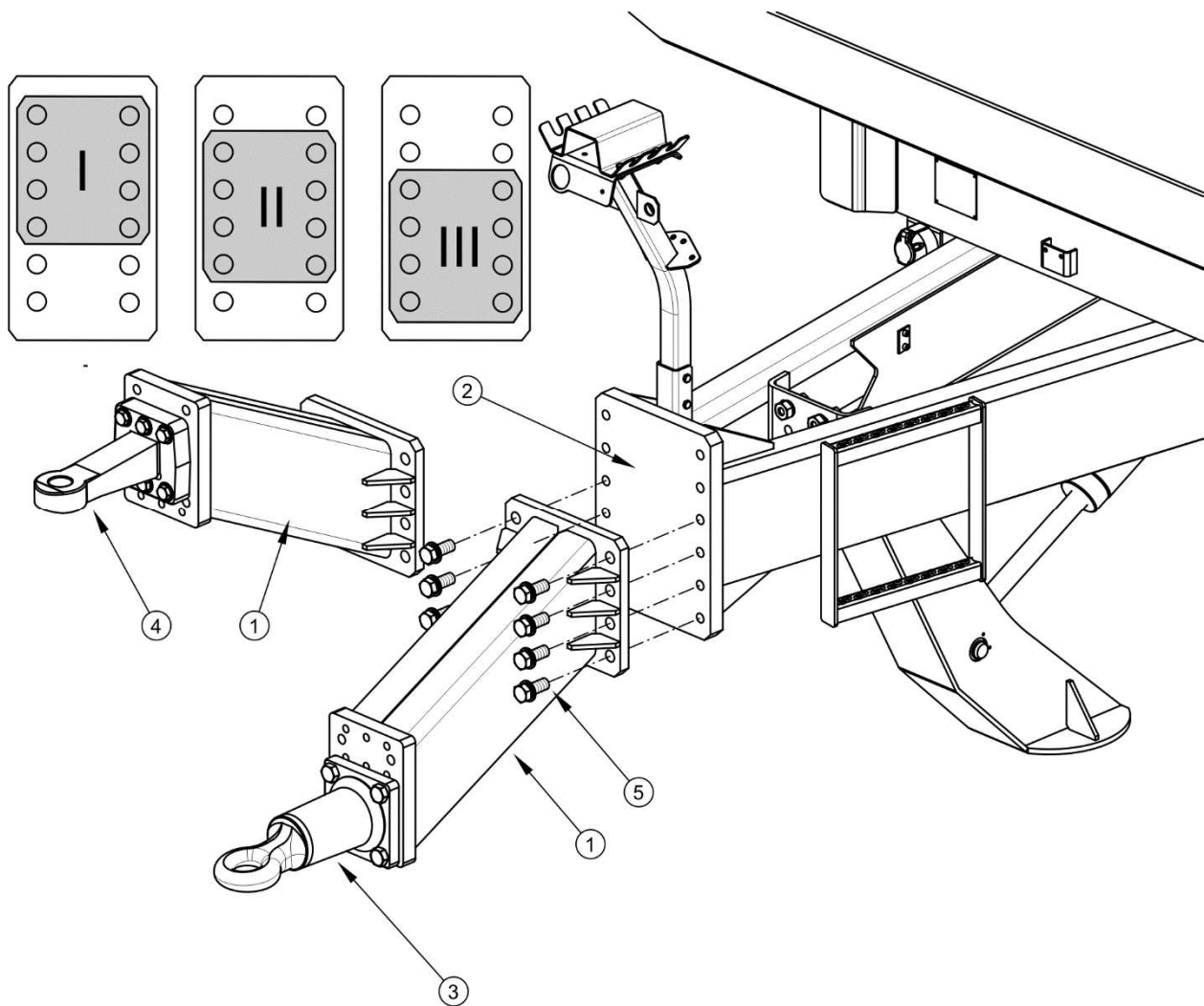

FIGURE 5.15 Adjustment of drawbar position

(1) drawbar, (2) faceplate, (3) rotating drawbar eye, (4) fixed drawbar eye, (5) fixing bolt

The drawbar height is controlled through the appropriate use of the holes on the drawbar plate (1) relative to the faceplate (2) - Figure (5.15). Drawbar positions (3) or (4) can also be adjusted by changing their position relative to the drawbar faceplate (1).

Scope of activities

- ➔ Immobilise trailer with parking brake.
- ➔ Place chocks under trailer wheels.
- ➔ Dismantle drawbar (1) from faceplate (2) by removing fixing bolts (5).
- ➔ If necessary, rotate the drawbar (1) by 180 degrees and set it in a new position.

- ⇒ Tighten the bolts (5) using the correct torque according to table (5.7).
- ⇒ The design of the drawbar (1), and the faceplate (2) allows the three settings (I) (II) (III).
- ➔ Set and attach proper hitching eye to the drawbar plate.
 - ⇒ Rotating drawbar eye or ball drawbar eye are used for the lower hitch. Fixed drawbar eye is used for the upper hitch.
 - ⇒ The drawbar design (1) makes it possible to set the drawbar eye in two positions.

5.13 TROUBLESHOOTING

TABLE 5.8 Troubleshooting

FAULT	CAUSE	REMEDY
Problem with moving off	Brake system pneumatic conduits not connected	Connect brake conduits (applies to pneumatic systems)
	Applied parking brake	Release parking brake.
	Damaged pneumatic system connection conduits	Replace.
	Leaking connections	Tighten, replace washers or seal sets, replace conduits.
	Control valve or braking force regulator damaged	Check valve, repair or replace.
Noise in axle hubs	Excessive bearing slackness	Check slackness and adjust if needed.
	Damaged bearings	Replace bearings.
	Damaged hub parts	Replace.

FAULT	CAUSE	REMEDY
Poor reliability of braking system	Insufficient pressure in the system	<p>Check pressure on tractor pressure gauge, wait till compressor fills tank to required pressure.</p> <p>Damaged air compressor in tractor Repair or replace.</p> <p>Damaged brake valve in tractor. Repair or replace.</p> <p>Leaking system conduits or connections. Check system for tightness.</p>
Excessive heating of axle hubs	Incorrect main or parking brake adjustment	Regulate setting of expander arms.
	Worn brake linings	Change brake shoes.
Incorrect hydraulic system operation	Improper hydraulic oil viscosity	Check oil quality, make sure that the oil in both machines is of the same type. If necessary change oil in tractor or in trailer.
	Insufficient tractor hydraulic pump output, tractor hydraulic pump is damaged	Check tractor hydraulic pump.
	Damaged or contaminated cylinder	Check cylinder piston rod (bending, corrosion), check cylinder for tightness (cylinder piston rod seal), if necessary, repair or replace the cylinder.
	Excessive cylinder loading	Check mechanism controlled by cylinder for mechanical damage.
Incorrect hydraulic system operation	Damaged hydraulic conduits	Check and ascertain that hydraulic conduits are tight, not fractured and properly tightened. If necessary, replace or tighten.

NOTES

A series of horizontal dotted lines for writing notes.

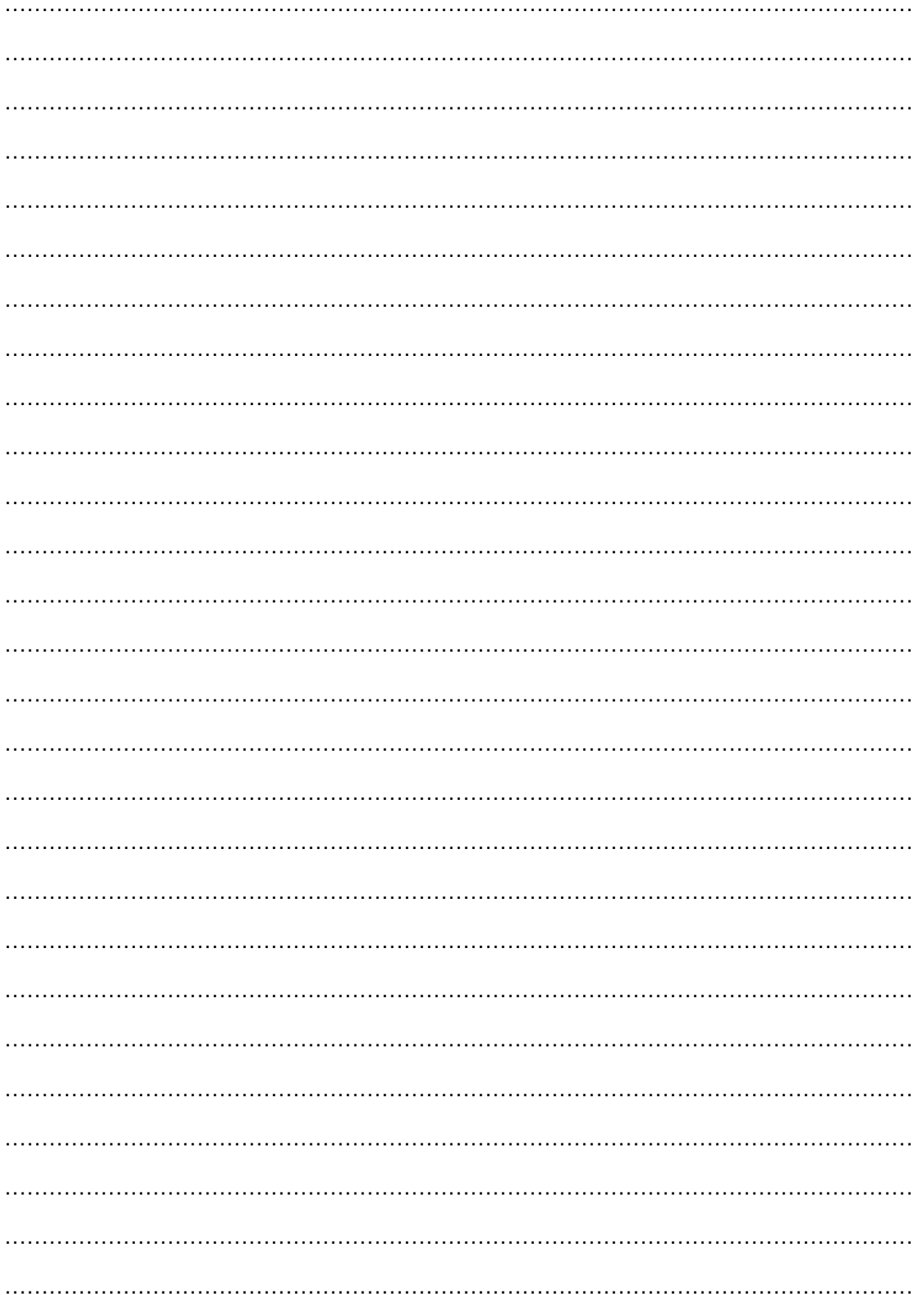

ANNEX A

Tyre dimensions

TRAILER VERSION	AXLE FRONT / REAR
T679	Wheel 385 / 65 R22,5reg. 160F TL ⁽¹⁾ Wheel 425 / 65 R22,5reg. 168F ⁽²⁾ Wheel 445 / 65 R22,5 TL ⁽²⁾ Wheel 445 / 65 R22,5reg. 170F TL ⁽³⁾ Wheel 445 / 65 R22,5. BT41 168K TL ⁽³⁾ Wheel 445 / 65 R22,5 HTR 168K TL ⁽³⁾ Wheel 500 / 60-R22,5 16PR 159A8 ⁽⁴⁾ Wheel 550 / 45-R22,5 16PR 159A8 ⁽⁵⁾ Wheel 560 / 45-22,5 152D TL ⁽⁵⁾

⁽¹⁾ - wheel disc 11.75x22.5; ET= -30

⁽²⁾ - wheel disc 13.00x22.5; ET= 0

⁽³⁾ - wheel disc 14.00x22.5; ET=0

⁽⁴⁾ - wheel disc 16.00x22.5; ET= -30

⁽⁵⁾ - wheel disc 16.00x22.5; ET= -50