



PRONAR Sp. z o.o.

17-210 NAREW, UL. MICKIEWICZA 101A, WOJ. PODLASKIE, POLAND

Phone.:	+48 085 681 63 29	+48 085 681 64 29
	+48 085 681 63 81	+48 085 681 63 82
Fax:	+48 085 681 63 83	+48 085 682 71 10

www.pronar.pl

OPERATOR'S MANUAL

TRAILER

PRONAR T654/2

TRANSLATION OF THE ORIGINAL DOCUMENT

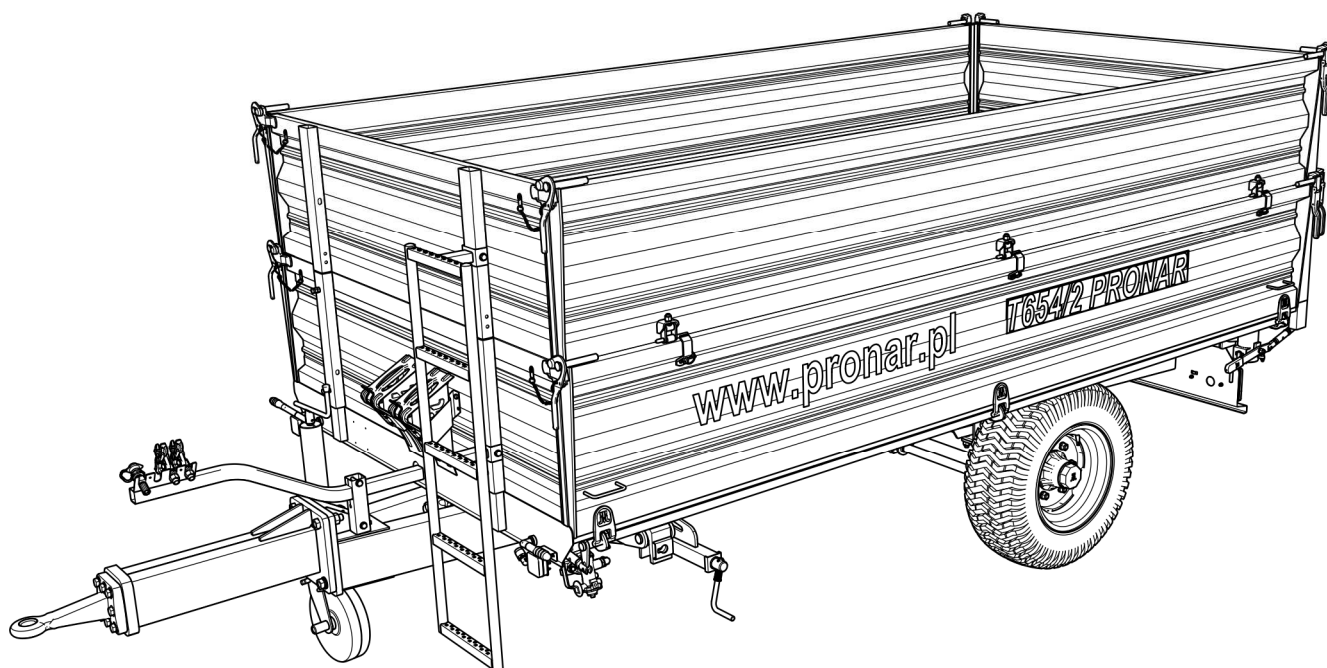

ISSUE 1A-10-2015

PUBLICATION NO. 487N-00000000-UM



Thank you for purchasing our trailer. In the interests of your safety and care for the reliability and durability of the machine, we ask that you familiarise yourself with the content of this manual.

Remember!!!

Before using the trailer for the first time, check if the wheels are properly tightened!!! Regularly check the technical condition of the machine in accordance with the attached schedule.

INTRODUCTION

Information contained herein is current as of the date of its publication. As a result of improvements, some numerical values and illustrations contained in this publication may not correspond to the factual specification of the machine delivered to the user. The manufacturer reserves the right to introduce design changes in manufactured machines that facilitate operation and improve the quality of their work, without making amendments to this Operator's Manual.

This Operator's Manual is an integral part of the machine. Before using the machine, the user must carefully read this Operator's Manual and observe all recommendations. This guarantees safe operation and ensures malfunction-free work of the machine. The machine is designed to meet obligatory standards, documents and legal regulations currently in force.

The manual describes the basic safety and operation rules of Pronar T654/2 trailer.

If the information contained in the Operator's Manual needs clarification, the user should refer for assistance to the sale point where the machine was purchased or to the manufacturer.

MANUFACTURER'S ADDRESS

*PRONAR Sp. z o.o.
ul. Mickiewicza 101A
17-210 Narew, Poland*

PHONE NUMBERS

<i>+48 085 681 63 29</i>	<i>+48 085 681 64 29</i>
<i>+48 085 681 63 81</i>	<i>+48 085 681 63 82</i>

SYMBOLS USED IN THIS MANUAL

Information, descriptions of danger, precautions, recommendations and orders associated with user safety instructions are indicated as follows:



and preceded by the word "**DANGER**". Failure to observe the instructions may endanger the machine operator's or other person's health or life.

Particularly important information and instructions, the observance of which is essential, are indicated with the sign:



and preceded by the word "**ATTENTION**". Failure to observe the instructions may lead to damage to the machine as a result of improper operation, adjustment or use.

In order to focus the user's attention on the need to perform periodical maintenance, the relevant section of the Operator's Manual is indicated with the sign:



Additional tips contained in this document refer to helpful information on the machine operation and are indicated as follows:



and preceded by the word "**TIP**".

DETERMINING THE DIRECTIONS FOR THE MANUAL'S NEEDS

Left side — a left hand side of the person facing the machine's forward travel direction.

Right side — a right hand side of the person facing the machine's forward travel direction.

SCOPE OF OPERATION STEPS

Operation steps are indicated with the following sign: ➡

The result of an operation/adjustment task or any notes on execution of the tasks performed is indicated with the sign ⇒



PRONAR Sp. z o.o.

ul. Mickiewicza 101 A
17-210 Narew, Polska

tel./fax (+48 85) 681 63 29, 681 63 81, 681 63 82,
681 63 84, 681 64 29

fax (+48 85) 681 63 83

http://www.pronar.pl

e-mail: pronar@pronar.pl

EC DECLARATION OF CONFORMITY OF THE MACHINERY

PRONAR Sp. z o.o. declares with full responsibility, that the machine:

Description and identification of the machinery	
Generic denomination and function:	AGRICULTURAL TRAILER
Type:	T654
Model:	-----
Serial number:	
Commercial name:	AGRICULTURAL TRAILER PRONAR T654 AGRICULTURAL TRAILER PRONAR T654/1 AGRICULTURAL TRAILER PRONAR T654/2

to which this declaration relates, fulfills all the relevant provisions of the Directive **2006/42/EC** of The European Parliament and of The Council of 17 May 2006 on machinery, and amending Directive 95/16/EC (Official Journal of the EU, L 157/24 of 09.06.2006).

The person authorized to compile the technical file is the Head of Research and Development Department at PRONAR Sp. z o.o., 17-210 Narew, ul. Mickiewicza 101A, Poland.

This declaration relates exclusively to the machinery in the state in which it was placed on the market, and excludes components which are added and/or operations carried out subsequently by the final user.

Narew, the 11/18/2015

Place and date

Z-CIA DYREKTORA
d/s technicznych
członek zarządu

Roman Ogiński

*Full name of the empowered person
position, signature*

TABLE OF CONTENTS

1	BASIC INFORMATION	1.1
1.1	IDENTIFICATION	1.2
1.1.1	TRAILER IDENTIFICATION	1.2
1.1.2	AXLE IDENTIFICATION	1.3
1.1.3	LIST OF FACTORY NUMBERS	1.4
1.2	PROPER USE	1.4
1.3	EQUIPMENT	1.8
1.4	TERMS & CONDITIONS OF WARRANTY	1.9
1.5	TRANSPORT	1.10
1.5.1	TRANSPORT ON VEHICLE.	1.11
1.5.2	INDEPENDENT TRANSPORT BY THE USER.	1.13
1.6	ENVIRONMENTAL HAZARDS	1.13
1.7	WITHDRAWAL FROM USE	1.14
2	SAFETY ADVICE	2.1
2.1	BASIC SAFETY RULES	2.2
2.1.1	USE OF TRAILER	2.2
2.1.2	HITCHING AND DISCONNECTING FROM TRACTOR	2.3
2.1.3	HITCHING AND UNHITCHING THE SECOND TRAILER	2.3
2.1.4	HYDRAULIC AND PNEUMATIC SYSTEMS	2.4
2.1.5	LOADING AND UNLOADING	2.5
2.1.6	TRANSPORTING THE MACHINE	2.7
2.1.7	TYRES	2.10
2.1.8	MAINTENANCE	2.11
2.2	DESCRIPTION OF MINIMAL RISK	2.13
2.3	INFORMATION AND WARNING DECALS	2.14

3	DESIGN AND OPERATION	3.1
3.1	TECHNICAL SPECIFICATION	3.2
3.2	TRAILER CONSTRUCTION	3.3
3.2.1	CHASSIS	3.3
3.2.2	LOAD BOX	3.6
3.2.3	MAIN BRAKE	3.9
3.2.4	HYDRAULIC TIPPING SYSTEM	3.14
3.2.5	PARKING BRAKE	3.16
3.2.6	LIGHTING SYSTEM	3.17
4	CORRECT USE	4.1
4.1	PREPARING FOR WORK BEFORE THE FIRST USE	4.2
4.1.1	CHECKING THE TRAILER AFTER DELIVERY	4.2
4.1.2	PREPARING THE TRAILER FOR FIRST HITCHING TO TRACTOR	4.3
4.2	HITCHING AND UNHITCHING THE TRAILER FROM TRACTOR	4.4
4.3	HITCHING AND UNHITCHING THE SECOND TRAILER	4.9
4.4	LOADING AND SECURING LOAD	4.11
4.4.1	GENERAL INFORMATION ABOUT LOADING	4.11
4.5	TRANSPORTING LOADS	4.18
4.6	UNLOADING	4.20
4.7	PROPER USE AND MAINTENANCE OF TYRES	4.25
5	MAINTENANCE	5.1
5.1	PRELIMINARY INFORMATION	5.2
5.2	SERVICING BRAKES AND AXLES	5.2
5.2.1	PRELIMINARY INFORMATION	5.2
5.2.2	CHECKING WHEEL AXLE BEARINGS FOR SLACKNESS	5.3
5.2.3	ADJUSTMENT OF SLACKNESS OF WHEEL AXLE BEARINGS	5.5

5.2.4	MOUNTING AND DISMOUNTING WHEEL, INSPECTION OF WHEEL NUT TIGHTENING	5.6
5.2.5	CHECKING AIR PRESSURE IN TYRES, EVALUATING TECHNICAL CONDITION OF TYRES AND STEEL WHEELS	5.9
5.2.6	CHECKING THICKNESS OF BRAKE SHOE LININGS	5.10
5.2.7	ADJUSTMENT OF MECHANICAL BRAKES	5.11
5.2.8	REPLACEMENT OF OVERRUN BRAKE CABLE AND ADJUSTMENT OF CABLE TENSION.	5.15
5.2.9	REPLACEMENT OF PARKING BRAKE CABLE AND ADJUSTMENT OF CABLE TENSION.	5.16
5.3	PNEUMATIC SYSTEM MAINTENANCE	5.19
5.3.1	PRELIMINARY INFORMATION	5.19
5.3.2	CHECKING AIR TIGHTNESS AND VISUAL INSPECTION OF PNEUMATIC SYSTEM	5.20
5.3.3	CLEANING THE AIR FILTERS	5.21
5.3.4	DRAINING WATER FROM AIR TANK	5.22
5.3.5	CLEANING THE DRAIN VALVE	5.24
5.3.6	CLEANING AND MAINTAINING PNEUMATIC CONDUIT CONNECTIONS AND PNEUMATIC SOCKETS	5.24
5.3.7	REPLACEMENT OF PNEUMATIC CONDUIT	5.25
5.4	HYDRAULIC SYSTEM MAINTENANCE	5.26
5.4.1	PRELIMINARY INFORMATION	5.26
5.4.2	CHECK HYDRAULIC SYSTEM TIGHTNESS	5.26
5.4.3	CHECKING TECHNICAL CONDITION OF HYDRAULIC CONNECTIONS AND SOCKETS.	5.27
5.4.4	REPLACEMENT OF HYDRAULIC CONDUITS	5.28
5.5	MAINTENANCE OF LIGHTING SYSTEM AND WARNING ELEMENTS	5.28
5.5.1	PRELIMINARY INFORMATION	5.28
5.6	TRAILER LUBRICATION	5.29
5.7	CONSUMABLES	5.34

5.7.1	HYDRAULIC OIL	5.34
5.7.2	LUBRICANTS	5.35
5.8	CLEANING THE TRAILER	5.35
5.9	STORAGE	5.37
5.10	TIGHTENING TORQUE FOR NUT AND BOLT CONNECTIONS	5.38
5.11	INSTALLATION AND DISASSEMBLY OF WALL EXTENSIONS	5.39
5.12	TROUBLESHOOTING	5.40

SECTION

1

**BASIC
INFORMATION**

1.1 IDENTIFICATION

1.1.1 TRAILER IDENTIFICATION

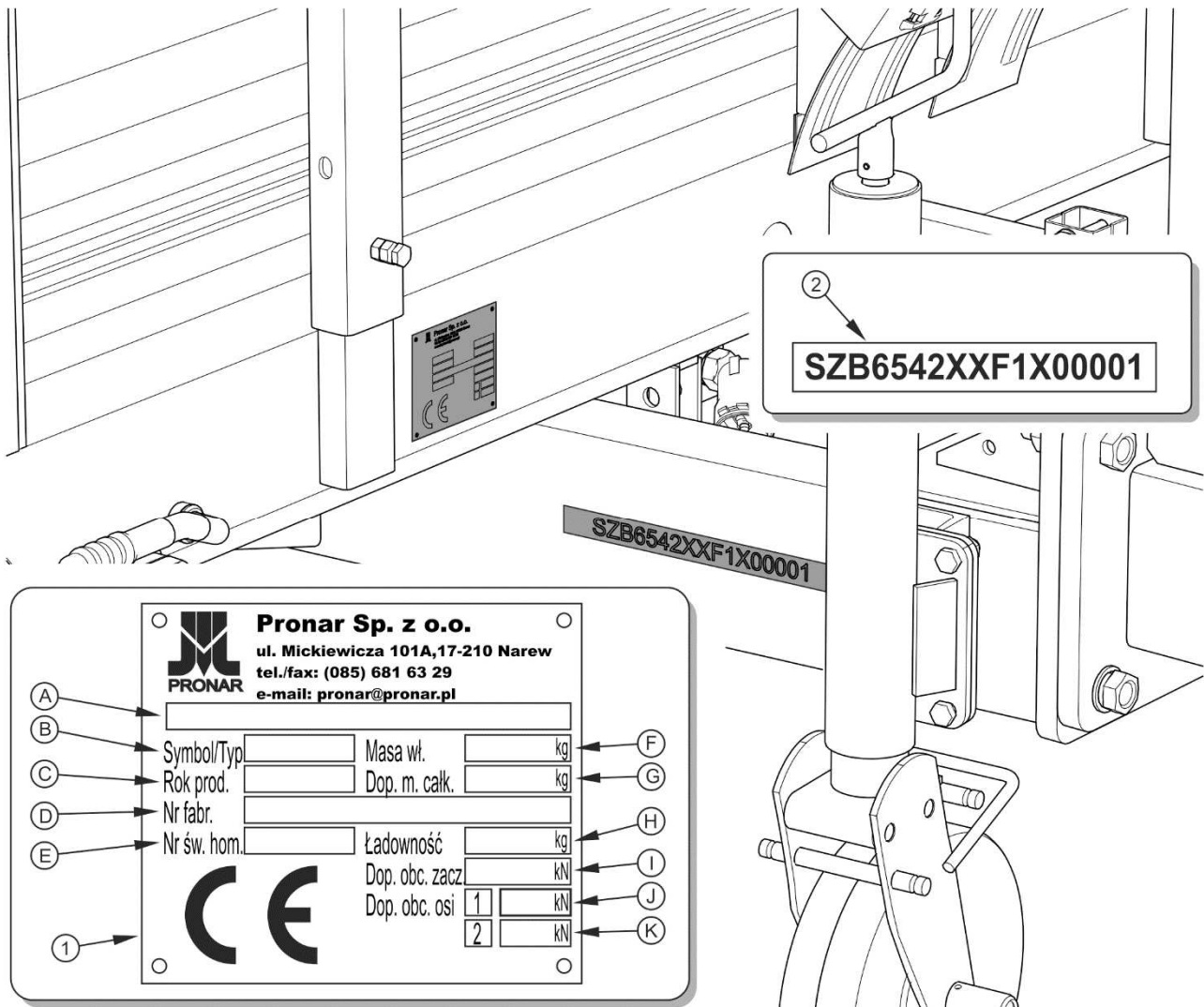

FIGURE 1.1 Location of the data plate and serial number

(1) data plate, (2) serial number

The trailer is marked with the data plate (1), and the factory number (2) located on a gold painted rectangle. The serial number is stamped into on the right side of the lower frame; the data plate is on the front beam of the upper frame – figure (1.1). When buying the trailer check that the serial numbers on the machine agree with the number written in the *WARRANTY BOOK*, in the sales documents and in the *OPERATOR'S MANUAL*. The meanings of the individual fields found on the data plate are presented in the table below:

TABLE 1.1 *Markings on data plate*

ITEM	MARKING
A	General description and purpose
B	Symbol / type of trailer
C	Year of manufacture
D	Seventeen digit vehicle identification number (VIN)
E	Official certificate number
F	Tare weight
G	Maximum gross weight
H	Carrying capacity
I	Permissible hitching system loading
J	Permissible axle 1 load
K	Permissible axle 2 load

1.1.2 AXLE IDENTIFICATION

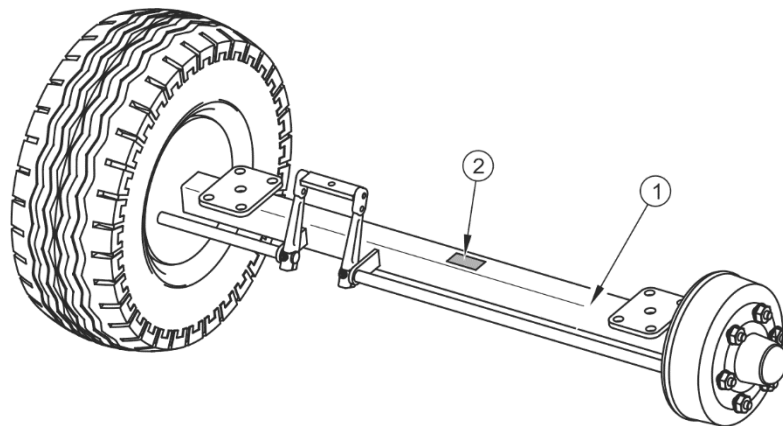
**FIGURE 1.2** *Location of the axle data plate*

(1) axle, (2) data plate

The factory number of the axle and its type are stamped onto the data plate (2) secured to the axle beam (1) – figure (1.2).

1.1.3 LIST OF FACTORY NUMBERS

VIN

S	Z	B	6	5	4	2	X	X			X					
---	---	---	---	---	---	---	---	---	--	--	---	--	--	--	--	--

AXLE FACTORY NUMBER

--

TIP



In the event of ordering a replacement part or in the case of the appearance of problems it is often essential to give the factory numbers of parts or the VIN number of the trailer, therefore it is recommended that these numbers are inscribed in the spaces above.

1.2 PROPER USE

The trailer is designed for transport of harvested crops and agricultural products as well as loose, bulk and long load materials at the farm and on public roads. It is acceptable to transport construction materials, mineral fertilisers and other loads, if fulfilling conditions indicated in section 4. Non-compliance with the recommendations concerning the carriage and loading of goods described by the Manufacturer and the road transport regulations in force in the country in which the trailer is used shall void the warranty and is regarded as the use of the machine contrary to its intended purpose.

The trailer is not intended or designed for transporting people, animals or goods classified as dangerous materials.

The trailer is constructed according to current safety requirements and engineering standards. The brake system and the light and indicator system meet the requirements of road traffic regulations. The maximum design speed of the standard version of the trailer is 25 km/h. However, the trailer speed may be higher (40km/h) than the maximum design speed (25km/h) if the trailer is equipped with optional axles and tyres available on request;

ATTENTION

The trailer must not be used for purposes other than those for which it is intended. The user MUST NOT:



- *transport people, animals, hazardous materials, chemically aggressive loads that will corrode the construction elements of the trailer (causing corrosion of steel, destruction of paint coat, dissolving plastic elements and destruction of rubber elements etc.),*
- *transport incorrectly secured load, which during travel may cause contamination of the road and natural environment,*
- *transport incorrectly secured load, which during travel may change position in load box or fall out of the load box,*
- *transport loads, whose centre of gravity may destabilise the trailer,*
- *transport loads, which have uneven load distribution and/or overload axles and suspension elements.*

Using it as intended also involves all actions connected with the safe and proper operation and maintenance of the machine. Due to the above, the user is obliged to:

- carefully read the *OPERATOR'S MANUAL* of the trailer and the *WARRANTY BOOK* and conform with the recommendations contained in these documents,
- understand the trailer's operating principle and how to operate it safely and correctly,
- adhere to the established maintenance and adjustment plans,
- comply with general safety regulations while working,
- prevent accidents,
- comply with the road traffic regulations and transport regulations in force in a given country, in which the trailer is used,
- carefully read the Operator's Manual and comply with its recommendations,
- only hitch the trailer to an agricultural tractor, which fulfils all the requirements made by the trailer's Manufacturer.

The trailer may only be used by persons, who:

- are familiar with the contents of this publication and with the contents of the agricultural tractor Operator's Manual,
- have been trained in trailer operation and safe operation,
- have the required authorisation to drive and are familiar with the road traffic regulations and transport regulations.

TABLE 1.2 *Requirements for agricultural tractor for standard version of the trailer*

CONTENTS	UNIT	REQUIREMENTS
Brake system - sockets		
Single conduit pneumatic system	-	according to ISO 1728
Double conduit pneumatic system	-	according to ISO 1728
Hydraulic system	-	according to ISO 7421-1
Maximum system pressure		
Single conduit pneumatic system	bar / kPa	5.8 / 580
Double conduit pneumatic system	bar / kPa	6.5 / 650
Hydraulic system	bar / MPa	150 / 15
Hydraulic tipper system		
Hydraulic oil	-	L HL 32 Lotos ⁽¹⁾
Maximum system pressure	bar / MPa	160 / 16
Oil demand:	l	8
Electrical system		
Electrical system voltage	V	12
Connection socket	-	7-pole compliant with ISO 1724
Required tractor hitch		
Type of hitch	-	Upper transport hitch for connecting with towing eye 40mm DIN-74054
	-	Hitches according to DIN 11028 DIN 11025 DIN 74051-1
Drawbar eye load	kg	1,000

CONTENTS	UNIT	REQUIREMENTS
Other requirements		
Min. tractor power	kW / Horsepower	24.7 / 33.6

(1) – use of other oil is permitted, on condition that it may be mixed with the oil in the trailer. Detailed information can be found on the product information card.

**TIP**

Tractor requirements depend on trailer accessories.

In the event that the trailer shall be hitched to a second trailer it must fulfil the requirements stipulated in table (1.3).

TABLE 1.3 *Requirements for second trailer*

CONTENTS	UNIT	REQUIREMENTS
Maximum gross weight	kg	6,100
Brake system - connectors		
Single conduit pneumatic system	-	connector compliant with ISO 1728
Double conduit pneumatic system	-	connector compliant with ISO 1728
Hydraulic system	-	connector compliant with ISO 7421-1
Maximum system pressure		
Single conduit pneumatic system	bar / kPa	5.8 / 580
Double conduit pneumatic system	bar / kPa	6.5 / 650
Hydraulic system	bar / MPa	150 / 15
Type of trailer	-	double axle trailer with swing drawbar
Hydraulic tipper system		
Hydraulic oil	-	L HL 32 Lotos ⁽¹⁾
Maximum system pressure	bar / MPa	160 / 16
Electrical system		
Electrical system voltage	V	12
Connection socket	-	7-pole compliant with ISO 1724

CONTENTS	UNIT	REQUIREMENTS
Trailer's drawbar		
Diameter of drawbar eye	mm	40

(1) – use of other oil is permitted, on condition that it may be mixed with the oil in the trailer. Detailed information can be found on the product information card.

1.3 EQUIPMENT

TABLE 1.4 *Trailer's equipment*

EQUIPMENT	STANDARD	ADDITIONAL
The Operator's Manual	•	
Warranty Book	•	
Double conduit pneumatic system	•	
Single conduit pneumatic system		•
Overrun brake ⁽¹⁾		•
Hydraulic brake		•
Rear hitch		•
Slow-moving vehicle warning sign		•
Warning reflective triangle		•
Set of walls (500 mm)	•	
Complete set of wall extensions (500 mm) with a ladder		•
Wheel chocks	•	
Chute		•
Connection lead for the electrical system	•	

EQUIPMENT	STANDARD	ADDITIONAL
Spare wheel		•
Support with wheel	•	
12V lighting system (with bulbs)	•	
12V lighting system (with LEDs)		•

(1) – only in the trailer version with overrun drawbar (25km/h)

Some standard equipment elements, which were listed in table (1.4), may not be present in the delivered trailer. This allows the possibility of ordering new machines with a different set of optional equipment, replacing standard equipment.

Information concerning tires is provided at the end of this publication in *ANNEX A*.

1.4 TERMS & CONDITIONS OF WARRANTY

PRONAR Sp. z o.o. Narew guarantees the reliable operation of the machine when it is used according to its intended purpose as described in the *OPERATOR'S MANUAL*. The repair period is specified in the *WARRANTY BOOK*.

The warranty does not cover those parts and sub-assemblies of the machine which are subject to wear in normal usage conditions, regardless of the warranty period. Consumables include the following parts/sub-assemblies:

- drawbar hitching eye,
- pneumatic system connector filters,
- tyres,
- brake shoes,
- bulbs and LED lamps,
- seals,

- bearings.

The warranty service only applies to such cases as: mechanical damage which is not the user's fault, factory defects of parts, etc.

In the event of damage arising from:

- mechanical damage which is the user's fault, road accidents,
- inappropriate use, adjustment or maintenance, use of the trailer for purposes other than those for which it is intended,
- use of damaged machine,
- repairs carried out by unauthorised persons, repairs carried out improperly,
- making unauthorised alterations to machine design,

the user will lose the right to warranty service.



TIP

Demand that the seller carefully and precisely fills out the Warranty Book and warranty repair coupons. A missing date of purchase or sale point stamp, may make the user ineligible for any warranty repair or refund.

The user is obliged to report immediately on noticing any wear in the paint coating or traces of corrosion, and to have the faults rectified whether they are covered by the warranty or not. For detailed Terms & Conditions of Warranty, please refer to the *WARRANTY BOOK* attached to each machine.

Modification of the trailer without the written consent of the Manufacturer is forbidden. In particular, do NOT weld, drill holes in, cut or heat the main structural elements of the machine, which have a direct impact on the machine operation safety.

1.5 TRANSPORT

The trailer is ready for sale completely assembled and does not require packing. Packing is only required for the machine's technical documentation and any extra equipment. The trailer is delivered to the user either transported on a vehicle or, after being attached to a tractor, independently (trailer towed with a tractor).

1.5.1 TRANSPORT ON VEHICLE.

Loading and unloading of trailer from vehicle shall be conducted using loading ramp with the aid of an agricultural tractor. During work, adhere to the general principles of occupational health and safety (OHS) applicable to reloading work. Persons operating reloading equipment must have the qualifications required to operate these machines. The trailer must be properly connected with the tractor according to the requirements in this Operators Manual. The trailer braking system must be started and checked before driving off or onto ramp.

The trailer should be attached firmly to the platform of the vehicle using straps or chains fitted with a tightening mechanism. Securing elements should be attached to permanent structural elements of the trailer (longitudinal members, crossbars etc.).

ATTENTION



When being road transported on a motor vehicle the trailer must be mounted on the vehicle's platform in accordance with the transport safety requirements and the regulations.

Driver of the vehicle should be particularly careful during travel. This is due to the vehicle's centre of gravity shifting upwards when loaded with the machine.

Use only certified and technically reliable securing measures. Carefully read the information contained in the Operator's Manuals for the given securing measures.

Use certified and technically reliable securing measures. Worn straps, cracked securing catches, bent or corroded hooks as well as elements damaged in a different way may be unsuitable for use. Carefully read the information stated in the Operator's Manual for the given securing measure. Chocks, wooden blocks or other objects without sharp edges should be placed under the wheels of the trailer to prevent it from rolling. Trailer wheel blocks must be nailed to the low platform planks of the vehicle or secured in another manner preventing their movement. The number of securing elements (cables, straps, chains and stay etc.) and the force necessary for their tensioning depends on a number of things, including weight of the trailer, the construction of vehicle carrying trailer, speed of travel and other conditions. For this reason it is impossible to define the securing plan precisely. A correctly secured trailer does not change its position with regard to the transport vehicle. The securing

elements must be selected according to the guidelines of the Manufacturer of these elements.

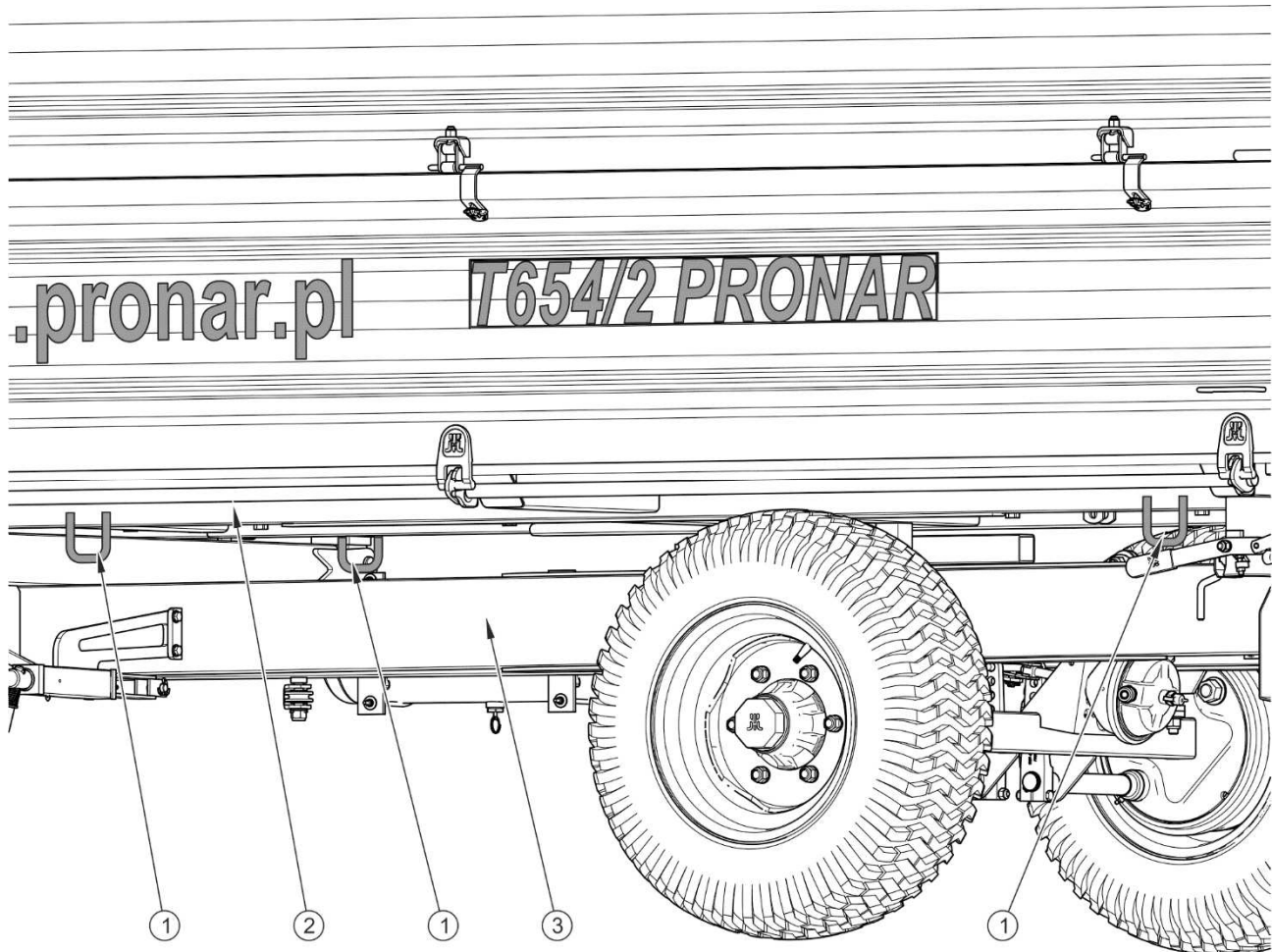

FIGURE 1.3 Positioning of transport lugs

(1) transport lug, (2) longitudinal member of upper frame, (3) longitudinal member of lower frame

In case of doubt apply a greater number of securing straps in order to immobilise the trailer. If necessary, sharp edges of trailer should be protected at the same time protecting the securing straps from breaking during transport.

During reloading work, particular care should be taken not to damage parts of the machine's fittings or the lacquer coating. The tare weight of the trailer in condition ready for travel is given in table (3.1).

**DANGER**

Incorrect use of securing measures may cause an accident.

1.5.2 INDEPENDENT TRANSPORT BY THE USER.**ATTENTION**

Before transporting independently, the tractor driver must carefully read this Operator's Manual and observe its recommendations.

In the event of independent transport by the user after purchase of the trailer, the user must read the trailer Operator's Manual and adhere to the recommendations contained therein. Independent transport involves towing the trailer with own agricultural tractor to destination. During transport adjust travel speed to the prevailing road conditions, but do not exceed the maximum design speed.

1.6 ENVIRONMENTAL HAZARDS

A hydraulic oil leak constitutes a direct threat to the natural environment owing to its limited biodegradability. Because of the low solubility of oil in water, it is not highly toxic to living organisms. An oil leak into water reservoirs may however lead to a reduction of the oxygen content.

While carrying out maintenance and repair work, which involves the risk of an oil leak, this work should take place on an oil resistant floor or surface. In the event of oil leaking into the environment, first of all contain the source of the leak, and then collect the leaked oil using available means. Remaining oil should be collected using sorbents, or by mixing the oil with sand, sawdust or other absorbent materials. The oil pollution, once gathered up, should be kept in a sealed, marked, hydrocarbon resistant container. The container should be kept away from heat sources, flammable materials and food.

**DANGER**

Used hydraulic oil or gathered remains mixed with absorbent material should be stored in a precisely marked container. Do not use food packaging for this purpose.

**TIP**

The hydraulic system of the trailer is filled with L-HL32 Lotos hydraulic oil.

Oil, which has been used up or is unsuitable for further use owing to a loss of its properties should be stored in its original packaging in the conditions described above. Waste oil should be taken to the appropriate facility dealing with the re-use of this type of waste. Waste code: 13 01 10. Detailed information concerning hydraulic oil may be found on the product's Material Safety Data Sheet.

**ATTENTION**

Waste oil should only be taken to the appropriate facility dealing with the re-use of this type of waste. Do NOT throw or pour oil into sewerage or water tanks.

1.7 WITHDRAWAL FROM USE

In the event of decision by the user to withdraw the trailer from use, comply with the regulations in force in the given country concerning withdrawal from use and recycling of machines withdrawn from use. Before commencing dismantling, totally remove the oil from the hydraulic system and reduce air pressure completely in the pneumatic braking system (e.g. using air tank drain valve).

Worn out or damaged parts that cannot be reclaimed should be taken to a collection point for recyclable raw materials. Hydraulic oil should be taken to the appropriate facility dealing with the re-use of this type of waste.

During dismantling personal protection equipment shall be used i.e. protective clothing, boots, gloves and protective goggles etc.



DANGER

Avoid contact of skin with oil. Do not allow used hydraulic oil to spill.

SECTION

2

SAFETY ADVICE

2.1 BASIC SAFETY RULES

2.1.1 USE OF TRAILER

- Before using the trailer, the user must carefully read this Operator's Manual and the *WARRANTY BOOK*. When operating the machine, the operator must comply with all recommendations contained in the Operator's Manual.
- The trailer may only be used and operated by persons qualified to drive agricultural tractors with a trailer.
- If the information contained in the Operator's Manual is difficult to understand, contact a seller, who runs an authorised technical service on behalf of the manufacturer, or contact the manufacturer directly.
- Careless and improper use and operation of the trailer, and non-compliance with the recommendations given in this operator's manual is dangerous to your health.
- Be aware of the existence of a minimal risk, and for this reason the fundamental basis for using this trailer should be the application of safety rules and sensible behaviour.
- The machine must never be used by persons who are not authorised to drive agricultural tractors, including children and people under the influence of alcohol, drugs or other abusive substances.
- Non-compliance with the safety rules of this Operator's Manual can be dangerous to the health and life of the operator and others.
- The trailer must not be used for purposes other than those for which it is intended. Anyone who uses the trailer other than the way intended takes full responsibility for himself for any consequences of this potentially improper use. Use of the machine for purposes other than those for which it is intended by the Manufacturer may invalidate the guarantee.
- Assembly and disassembly of wall extensions should be carried out with the use of appropriate platforms, ladders or when standing on a ramp. These fittings must be in good condition to fully protect the persons working on them against falling. The above procedure should be performed by at least two persons.

- The user is obliged to acquaint himself with the construction, action and the principles of safe usage of the trailer.

2.1.2 HITCHING AND DISCONNECTING FROM TRACTOR

- Do NOT hitch the trailer to tractor if the tractor does not fulfil the requirements specified by the Manufacturer (minimum tractor power demand, wrong hitch, etc.) – compare table (1.2) *AGRICULTURAL TRACTOR REQUIREMENTS*. Before hitching trailer make certain that oil in external hydraulic system of tractor may be mixed with the hydraulic oil of the trailer.
- Before hitching the trailer check that both machines are in good technical condition.
- While connecting the trailer to the tractor, use the appropriate hitch. After completing the hitching of the machines check the safety of the hitch Carefully read the tractor Operator's Manual. If the tractor is equipped with an automatic hitch, make certain that the coupling operation is completed.
- Be especially careful when hitching the machine.
- When hitching, there must be nobody between the trailer and the tractor.
- Do NOT proceed with disconnecting trailer from the tractor when load box is raised.
- Hitching and unhitching the trailer may only take place when the machine is immobilised with the parking brake.

2.1.3 HITCHING AND UNHITCHING THE SECOND TRAILER

- Do NOT couple a second trailer if it does not fulfil the requirements specified by the Manufacturer (lack of required drawbar eye, exceeding permissible total weight, etc.) – compare table (1.3) *REQUIREMENTS FOR SECOND TRAILER*. Before connecting machines make certain that the oil in both trailers may be mixed.
- Only trailer built on a double axle chassis with permissible total weight described in table (1.3) may be hitched to the trailer.

- Before hitching the trailer check that both machines are in good technical condition.
- Be especially careful when hitching the machine.
- When hitching, there must be nobody between the trailers. Person assisting in hitching the machines should stand outside the area of danger and be visible to the tractor driver at all times.
- Do NOT proceed with disconnecting the second trailer from the tractor when load box is raised.
- After completing the coupling of the trailer check the safety of the hitch.

2.1.4 HYDRAULIC AND PNEUMATIC SYSTEMS

- When operating, the hydraulic and pneumatic systems are under high pressure.
- Regularly check the technical condition of the connections and the hydraulic and pneumatic conduits. There must be no oil or air leaks.
- Cut-off valve in the hydraulic tipping system limits the tipping angle of the load box when tipped to the sides and to the rear. The length of the control cable controlling this valve is factory adjusted by the Manufacturer and must not be changed when the trailer is used.
- In the event of malfunction of the hydraulic or pneumatic system, do not use the trailer until the malfunction is corrected.
- When connecting the hydraulic conduits to the tractor, make sure that the hydraulic system of the tractor and the hydraulic system of the trailer are not under pressure. If necessary, reduce residual pressure in the system.
- In the event of injuries being caused by pressurised hydraulic oil, contact a doctor immediately. Hydraulic oil may penetrate the skin and cause infections. In the event of contact of oil with eyes, rinse eyes with a large quantity of water and in the event of the occurrence of irritation consult a doctor. In the event of contact of oil with skin wash the area of contact with water and soap. Do NOT apply organic solvents (petrol, kerosene).
- Use the hydraulic oil recommended by the Manufacturer.

- After changing the hydraulic oil, the used oil should be properly disposed of. Used oil or oil which has lost its properties should be stored in original containers or replacement containers resistant to action of hydrocarbons. Replacement containers must be clearly marked and appropriately stored.
- Do not store hydraulic oil in packaging designed for storing food or foodstuffs.
- Rubber hydraulic conduits must be replaced every 4 years regardless of their technical condition.

2.1.5 LOADING AND UNLOADING

- Loading and unloading work should be carried out by persons experienced in this type of work.
- Use only original tipping pins with a handle. Using third-party pins could damage the trailer. When tipping the load box and travelling, the pins must be located in the load box sockets.
- The trailer is not intended for transporting people, animals or hazardous materials.
- The load must be arranged in such a way that it does not threaten the stability of the trailer and does not hinder driving.
- The arrangement of the load may not cause an overload on the axle and drawbar of the trailer.
- Incorrect load distribution and overloading the machine may cause the trailer to tip over or cause damage to its components.
- Do NOT climb on load box during loading and unloading.
- Unloading and loading of trailer may only take place when the machine is positioned on level and hard surface and connected to tractor. Tractor and trailer must be placed to drive forwards.
- Ensure that during unloading / loading or raising the load box nobody is near the trailer. Before tipping load box ensure that there is visibility and make certain that there are no bystanders.

- During loading and unloading the trailer the drawbar eye and the tractor hitch are subjected to great vertical loading.
- Before raising load box the tipping pins should be placed on the intended unloading side. Check if the pins are correctly inserted and secured.
- Keep a safe distance from overhead electric power lines during unloading and when load box is raised.
- When opening load box side wall locks take particular care, because of the pressure of the load on the wall.
- Do NOT tip of the load box in windy conditions.
- If the additional set of wall extensions is used, exercise particular caution when unloading bulk materials and unload the materials by tipping the trailer's load box to the rear only.
- When using the trailer with the set of wall extensions there is an increased risk of loss of trailer stability, trailer overturning, failure of the trailer's structural elements, insufficient visibility of the elements of the trailer's body, uncontrolled movements of the load box on uneven terrain.
- Pay attention to safety of unloading on uneven terrain. Make certain that there is nobody near the trailer.
- If the load does not pour from the raised load box immediately cease unloading. The trailer may only be tipped again after removing the object which prevented the load from pouring.
- During winter, particular attention must be paid to loads which may freeze during transport. When tipping the load box with frozen load the trailer may become unstable and tip over.
- Do NOT raise the load box if there is any danger whatsoever that the load box will tip over.
- Do NOT tip the loaded load box when the walls are closed.
- Do NOT jerk the trailer forwards if load is bulky or reluctant to pour and does not unload.

- After completed unloading, ensure that the load box is empty.
- Do NOT drive with the load box raised.
- When closing or opening the rear grain chute gate or the walls and extensions take particular care to avoid crushing fingers.
- Do NOT go or place hand between opened walls and load box.
- Lower the load box before proceeding to deal with a malfunction. If it is necessary to raise the load box then secure it against dropping with the aid of supports. The load box may not be loaded. The trailer must be hitched to the tractor and secured with chocks and parking brake.

2.1.6 TRANSPORTING THE MACHINE

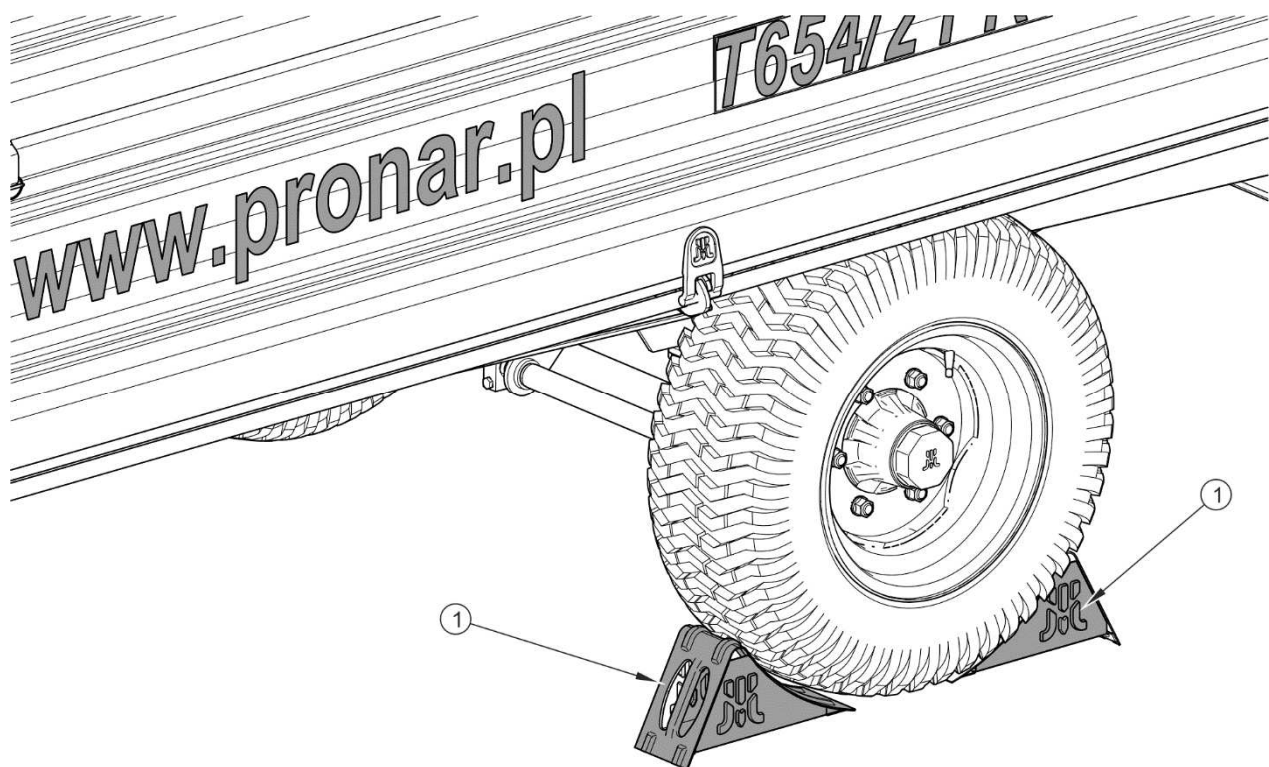

FIGURE 2.1 *Method of placing chocks*

(1) *wheel chock*

- During travel on public roads comply with the road traffic regulations and transport regulations in force in a given country, in which the trailer is used.
- Do not exceed the maximum design speed.

- Adjust speed to road conditions.
- Chocks (1) should be placed only under one wheel (one chock in front of the wheel, the other behind the wheel - figure (2.1)).
- The machine must NOT be left unsecured. When not connected to the tractor, the trailer must be immobilised with parking brake and protected against rolling with chocks or other objects without sharp edges placed under the front and back wheels.
- Before driving make sure that the trailer is properly hitched to the tractor, especially if coupling bolts are secure.
- Vertical load borne by the trailer drawbar eye affects the steering of the agricultural tractor.
- Do NOT move off or drive when load box is raised.
- Prior to moving off, make sure that the tipping pins connecting the load box with the lower frame and the wall pins (in case of wall extensions) are secured against falling out. Check if the rear wall slide gate is secured. Check that all walls and extensions are properly closed.
- Before using the trailer always check its technical condition, especially in terms of safety. In particular, check the technical condition of the hitch system, the axle system, the brake system, indicator lights and the connective elements of the hydraulic, pneumatic and electrical systems.
- Before driving off check that the parking brake is released, the braking force regulator is positioned in the proper position (applies to pneumatic systems with manual three-position regulator).
- The trailer is designed to operate on slopes up to 5°. When driving across such slopes, adjust speed to the terrain conditions and exercise particular caution. Driving trailer across terrain with steeper slopes may cause the trailer to tip over as a result of loss of stability. Prolonged driving across steep ground may lead to loss of braking efficiency.
- While driving on public roads, the trailer and the tractor must be fitted with a certified or authorised reflective warning triangle.

- Periodically drain water from the air tanks in pneumatic system. During frosts, freezing water may cause damage to pneumatic system components.
- Reckless driving and excessive speed may cause accidents.
- A load protruding beyond the outline of the trailer should be marked according to the road traffic regulations. Do NOT transport loads forbidden by the Manufacturer.

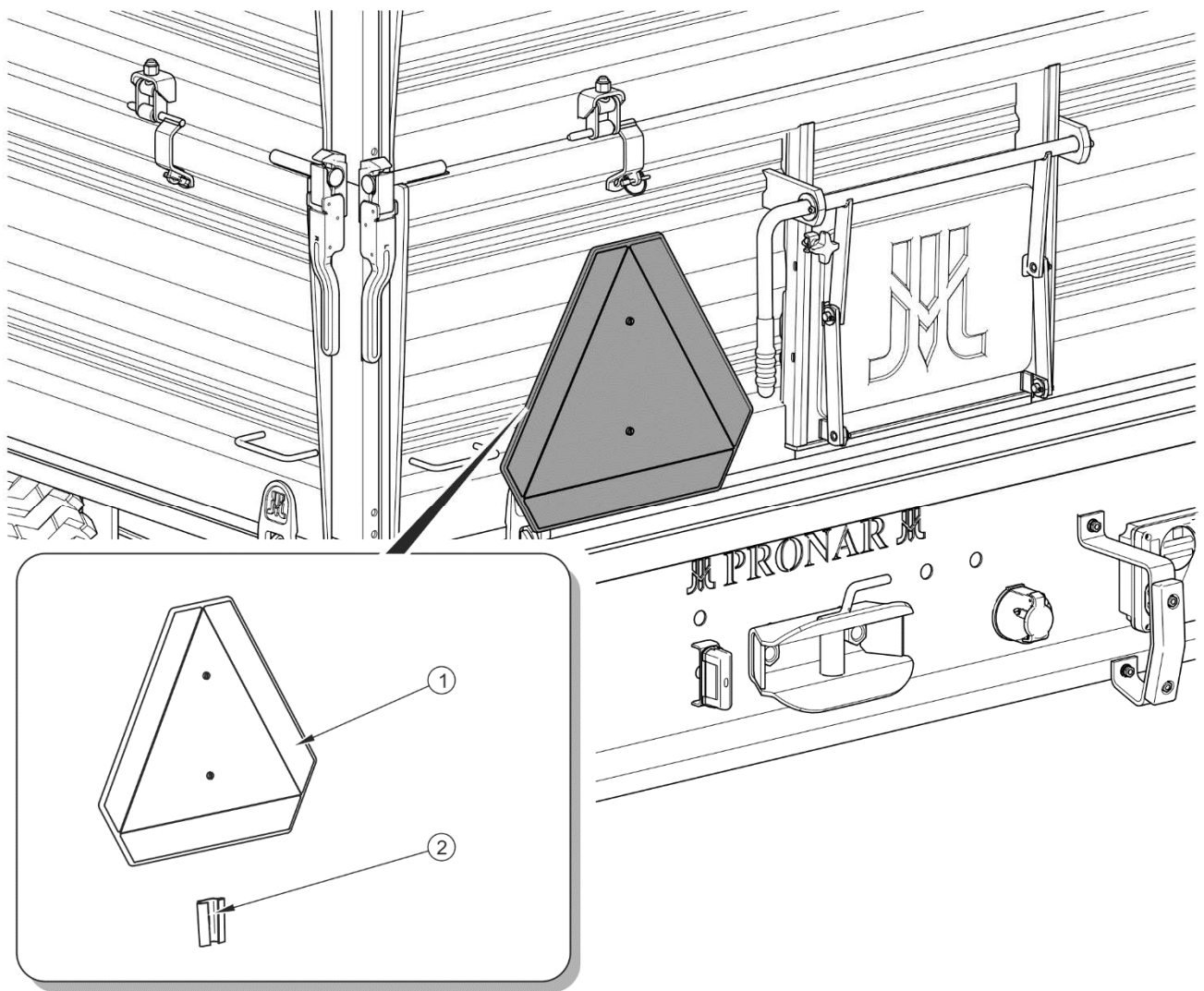

FIGURE 2.2 *Mounting place for slow-moving vehicle warning sign*

(1) slow-moving vehicle warning sign, (2) attachment point

- Do NOT exceed the trailer's maximum carrying capacity. Exceeding the carrying capacity may lead to damage to the machine, loss of stability while driving, scattering of the load and danger while driving. The brake system is adjusted to

the gross weight of the trailer, exceeding the weight limit causes drastic reduction of basic braking effectiveness.

- Prolonged driving across steep ground may lead to loss of braking efficiency.
- If the trailer is the last vehicle in the group, - figure (2.2), a slow-moving vehicle warning sign should be placed on the trailer's rear load box wall. The warning sign (1) should be attached using the specifically prepared holder (2), riveted to the rear wall of the load box.
- Load must be uniformly distributed and it must not obstruct visibility or hinder driving.
- The load must be secured so that it cannot move or fall over.
- During reversing one should use the assistance of another person. During manoeuvring the person helping must stay at a safe distance from the danger zone and be visible all the time to the tractor driver.
- Do NOT attempt to board trailer while travelling.
- Do NOT park trailer on slope.

2.1.7 TYRES

- When working with tyres, the trailer should be immobilised with parking brake and secured against rolling by placing chocks under wheel. Wheels can be taken off the trailer axle only when the trailer is not loaded.
- Repair work on the wheels or tyres should be carried out by persons trained and entitled to do so. This work should be carried out using appropriate tools.
- Inspect tightness of wheel nuts after the first use of the trailer, every 2 - 3 hours during first month of work and then every 30 hours of use (travel). The inspection should be repeated individually if a wheel has been removed from the wheel axle. Wheel nuts should be tightened according to recommendations provided in section 5 *MAINTENANCE*.
- Avoid potholes, sudden manoeuvres or high speeds when turning.
- Check the tyre pressure regularly. Air pressure in tyres should be also checked during the whole day of intensive work. Please note that higher temperatures

could raise tyre pressure by as much as 1 bar. At high temperatures and pressure, reduce load or speed. Do not release air from warm tyres to adjust the pressure or the tyres will be underinflated when temperatures return to normal.

- Protect tyre valves using suitable caps to avoid soiling.

2.1.8 MAINTENANCE

- During the warranty period, any repairs may only be carried out by Warranty Service authorised by the manufacturer. After the expiry of the warranty period it is recommended that possible repairs to the trailer be performed by specialised workshops.
- In the event of any fault or damage whatsoever, do not use the trailer until the fault has been fixed.
- While performing maintenance work, use proper, close-fitting protective clothing, gloves, protective shoes, protective goggles and appropriate tools.
- Any modification to the trailer frees the manufacturer from any responsibility for damage or detriment to health, which may arise as a result.
- The trailer can only be stood on when it is absolutely motionless and the tractor engine is switched off. Tractor and trailer should be immobilized with parking brake and chocks should be placed under the trailer wheels. Ensure that unauthorised persons do not have access to the tractor cab.
- Regularly check the condition of nut and bolt connections, in particular connections of drawbar eye with drawbar and wheel nuts.
- Service inspections should be carried out according to the frequency specified in this Operator's Manual.
- Before beginning work, which requires raising the load box, it should be emptied and secured with the support leg. The trailer must at this time be hitched to the tractor and secured with chocks and parking brake.
- Before beginning repair works on hydraulic or pneumatic systems reduce oil or air pressure completely.
- Servicing and repair work should be carried out in line with the general principles of workplace health and safety. In the event of injury, the wound must be

immediately cleaned and disinfected. In the event of more serious injuries, seek a doctor's advice.

- Repair, maintenance and cleaning work should be carried out with the tractor's engine switched off and the ignition key removed. Tractor and trailer should be immobilized with parking brake and chocks should be placed under the trailer wheels. Ensure that unauthorised persons do not have access to the tractor cab.
- During maintenance or repair work, the trailer may be unhitched from tractor, but it must be secured with chocks and parking brake. During this work the load box may not be raised.
- Should it be necessary to change individual parts, use only those parts indicated by the Manufacturer. Non-adherence to these requirements may put the user and other people's health and life at risk, and also damage the machine and invalidate the guarantee.
- Before welding or electrical work, the trailer should be disconnected from the power supply. The paint coating should be cleaned. Burning paint fumes are poisonous for people and animals. Welding work should be carried out in a well lit and well ventilated space.
- During welding work pay attention to flammable or fusible elements (parts of the pneumatic, electric and hydraulic systems, plastic parts). If there is a risk that they will catch fire or be damaged, they should be removed or covered with non-flammable material before commencing welding work. Before beginning work, prepare a CO2 or foam extinguisher.
- In the event of work requiring the trailer to be raised, use properly certified hydraulic or mechanical lifts for this purpose. After lifting the machine, stable and durable supports must also be used. Work must not be carried out under a trailer, which has only been raised with a lift or jack.
- The trailer must not be supported using fragile elements (bricks or concrete blocks).
- After completing work associated with lubrication, remove excess oil or grease. The trailer should be kept clean and tidy.

- Exercise caution when climbing on top of the load box. Climbing on top of the load box is possible using the ladder placed on the front wall and wall extension. The ladder and wall extensions are available as optional equipment. Components not intended to aid access may not be used for this purpose. Before entering load box prevent trailer moving with parking brake and chocks.
- Do NOT make independent repairs of control valve, brake cylinders, tipping cylinder and braking force regulator. In the event of damage to these elements, repair should be entrusted to authorised service point or elements should be replaced with new ones.
- Do NOT make repairs to drawbar (straightening, pad welding or welding). A damaged drawbar must be replaced.
- Do NOT install additional appliances or fittings not according to the specifications defined by the Manufacturer.
- The trailer may only be towed when axles and wheels, lighting system and brakes are reliable.

2.2 DESCRIPTION OF MINIMAL RISK

Pronar Sp. z o. o. in Narew has made every effort to eliminate the risk of accidents. There is, however, a certain residual risk, which could lead to an accident, and this is connected mainly with the actions described below:

- using the trailer for purposes other than those for which it is intended,
- being between the tractor and the trailer while the engine is working and when the machine is being attached or hitched to second trailer
- being on the machine during work,
- not maintaining safe distance during loading or unloading of trailer,
- operation of the trailer by unauthorised persons or persons under the influence of alcohol or other intoxicating substances,
- making modifications to the machine without the consent of the Manufacturer,
- cleaning, maintenance and technical checks of the trailer,

- presence of persons or animals in areas invisible from the driver's position.





The residual risk may be kept to a minimum by following the recommendations below:





- operate the machine in prudent and unhurried manner,
- sensibly apply the remarks and recommendations contained in the Operator's Manual,
- maintain a safe distance from forbidden or dangerous places during unloading, loading and hitching trailer,
- carry out repairs and maintenance work in line with operating safety rules,
- repair and maintenance work should be carried out by persons trained to do so,
- use close fitting protective clothing and appropriate tools,
- ensure unauthorised persons have no access to the machine, especially children.
- maintain a safe distance from forbidden or dangerous places
- a ban on being on the machine during travel, loading or unloading.

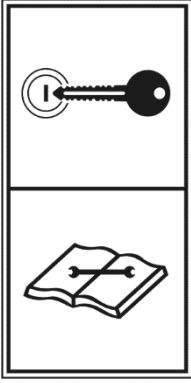

2.3 INFORMATION AND WARNING DECALS

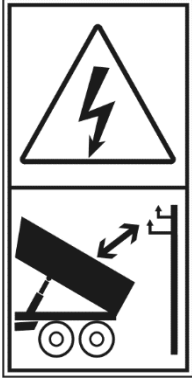
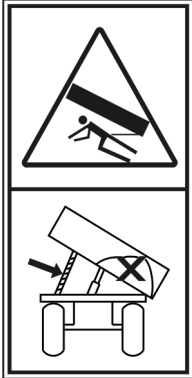
The trailer is labelled with the information and warning decals mentioned in table (2.1). The symbols are positioned as presented in figure (2.3). Throughout the time it is in use, the user of the machine is obliged to take care that notices and warning and information symbols located on the trailer are clear and legible. In the event of their destruction, they must be replaced with new ones. Safety decals are available from your PRONAR dealer or directly from PRONAR customer service. New assemblies, changed during repair, must be labelled once again with the appropriate safety signs. During trailer cleaning do not use solvents which may damage the coating of information label stickers and do not subject them to strong water jets.

TABLE 2.1 *Information and warning decals*

ITEM	DECAL	MEANING
1		<p>Trailer version. 487N-00000001</p>
2		<p>Caution! Before starting work, carefully read the Operator's Manual. 70N-00000004</p>
3		<p>Before beginning servicing or repairs, turn off tractor engine and remove key from ignition Ensure that unauthorised persons do not have access to the tractor cab. 70N-00000005</p>
4		<p>Before climbing onto the trailer, switch off tractor's engine and remove key from ignition. 29N-00000030</p>

ITEM	DECAL	MEANING
5		<p>Caution! Danger of electric shock.</p> <p>Keep a safe distance from overhead electric power lines during unloading.</p> <p>58N-0000020</p>
6		<p>Danger of crushing</p> <p>Do NOT perform any maintenance or repairs on the load box that is loaded, raised or not supported.</p> <p>29N-0000029</p>
7		<p>Regularly check if the nuts and bolts fixing the wheels and other components are properly tightened.</p> <p>104N-0000006</p>
8		<p>Grease the trailer according to the recommendations in the Operator's Manual</p> <p>104N-0000004</p>
9		<p>Conduit supplying hydraulic brake system.</p> <p>29N-0000028</p>

ITEM	DECAL	MEANING
10		Conduit supplying hydraulic tipping system. 29N-0000027
11		Air pressure in the tyres. ⁽¹⁾
12		Manufacturer's website. 62N-0000014

(1) – pressure value should be adapted to tyres

Numbers in the item column correspond to labels in figure (2.3)

Decals – items (9) and (10) are placed on hydraulic conduits.

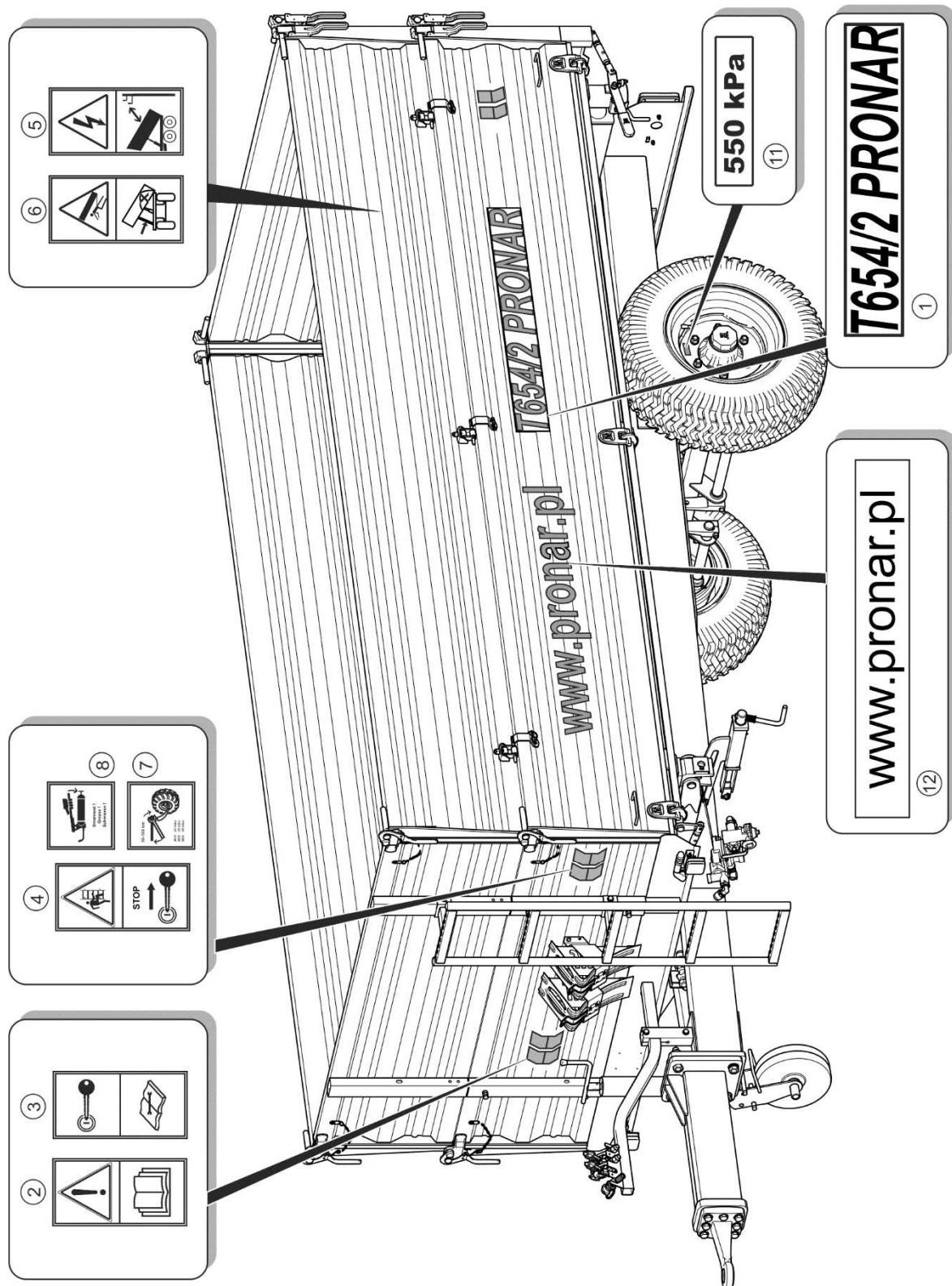

FIGURE 2.3 Locations of information and warning decals.

SECTION

3

**DESIGN AND
OPERATION**

3.1 TECHNICAL SPECIFICATION

TABLE 3.1 Basic technical data of the standard trailer version

CONTENTS	UNIT	
Trailer dimensions		
Total length	mm	4,960
Total width	mm	1,990
Total height	mm	1,430
Internal load box dimensions		
Length	mm	3,500
Width	mm	1,820
Height	mm	500
Weight and carrying capacity		
Tare weight	kg	1,190
Maximum gross weight	kg	6,100
Maximum carrying capacity	kg	4,910*
Other information		
Wheel track	mm	1,400
Cargo capacity	m ³	3.2
Load surface	m ²	6.4
Lift of load surface	mm	890
Load box tipping angle		
- to the sides	(°)	46
- to the rear	(°)	50
Electrical system voltage	V	12
Maximum design speed	km/h	25
Noise emission level	dB	below 70
Minimum tractor power demand	hp / kW	33.6 / 24.7
Hydraulic oil demand	l	8
Maximum drawbar eye load	kg	1,000

*- This parameter depends on legal restrictions existing in a given market and on the trailer equipment. It may differ from the given value.

3.2 TRAILER CONSTRUCTION

3.2.1 CHASSIS

Trailer chassis consists of subassemblies indicated in figure (3.1). Lower frame (1) is a structure welded from steel sections. Lower frame design depends on configuration of a given trailer version. Individual trailer versions have different drawbars – figure (3.2). The main load-bearing elements of the lower frame (1) are two longitudinal members connected with each other by means of crossbars. In the middle section there is a socket (2) used for mounting the hydraulic tipping cylinder. Load box support (10) is mounted in front of the sockets of the tipping cylinder. At the rear part of the lower frame, the rear beam (7) is welded, which is terminated with ball pins. The support structure of the upper frame and the interlocking method allows tipping of the load box to the side and to the rear. Pins for mounting the upper frame are welded on the left and right side of the front crossbar (8) of the lower frame.

Lights support beam (3) is located in the rear section of the chassis. All electrical system components and pneumatic system sockets for connecting the second trailer are mounted on the beam. Rear hitch (9) designed for hitching a second (double axle) trailer is bolted to the rear beam. A pin with diameter of $\varnothing 33$ mm is suitable for connecting with drawbar eye of $\varnothing 40$ mm. Rear wall fender (13) is installed on the right side of the rear beam. The purpose of the fender is to eliminate the impacts of the rear wall when opening the side wall.

The trailer suspension consists of axle (4) that is mounted to lower frame (1) by means of bolts. Axle is made from square bars terminated with a pin, where wheel hubs are mounted on cone bearings. The wheels are single and equipped with shoe brakes activated by mechanical cam expanders. In the trailer version with overrun brake (figure (3.2)), the standard axle is replaced by the overrun axle equipped with safety mechanism that prevents blocking vehicle wheels while driving backwards.

In the front section of the lower frame (1), there is a folding jockey wheel (11). Conduit bracket (12) is bolted next to the support. Drawbar (5) is bolted to the mounting plate in the front section of the lower frame. Drawbar hitching eye $\varnothing 40$ (6) is bolted to the drawbar. Three versions of trailer are available depending on type of drawbar used – figure (3.2).

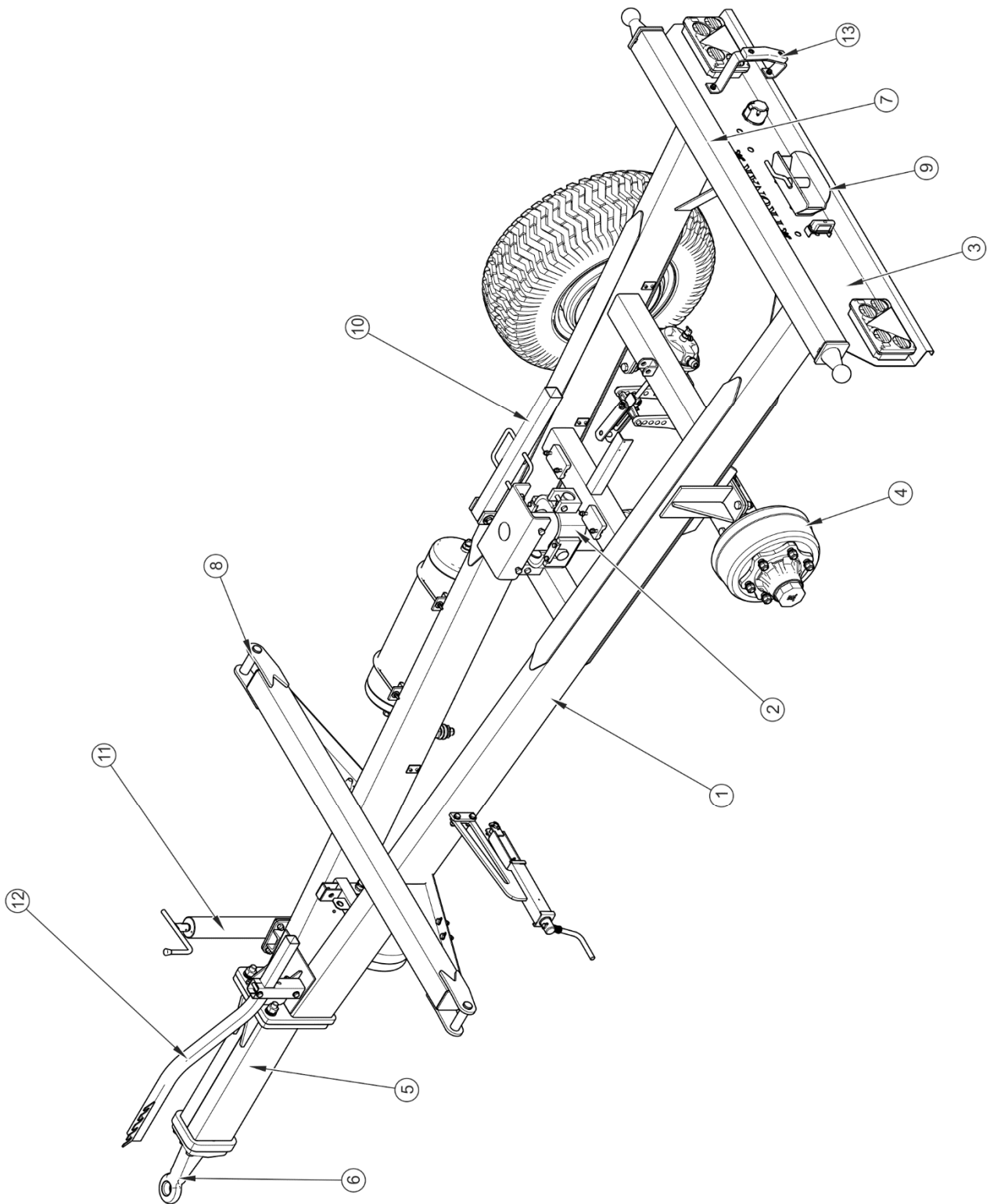

FIGURE 3.1 *Trailer chassis*

(1) lower frame, (2) tipping cylinder socket, (3) lights support beam, (4) axle, (5) drawbar, (6) drawbar hitching eye, (7) rear beam, (8) front crossbar, (9) hitch, (10) load box support, (11) trailer support, (12) conduit bracket, (13) fender

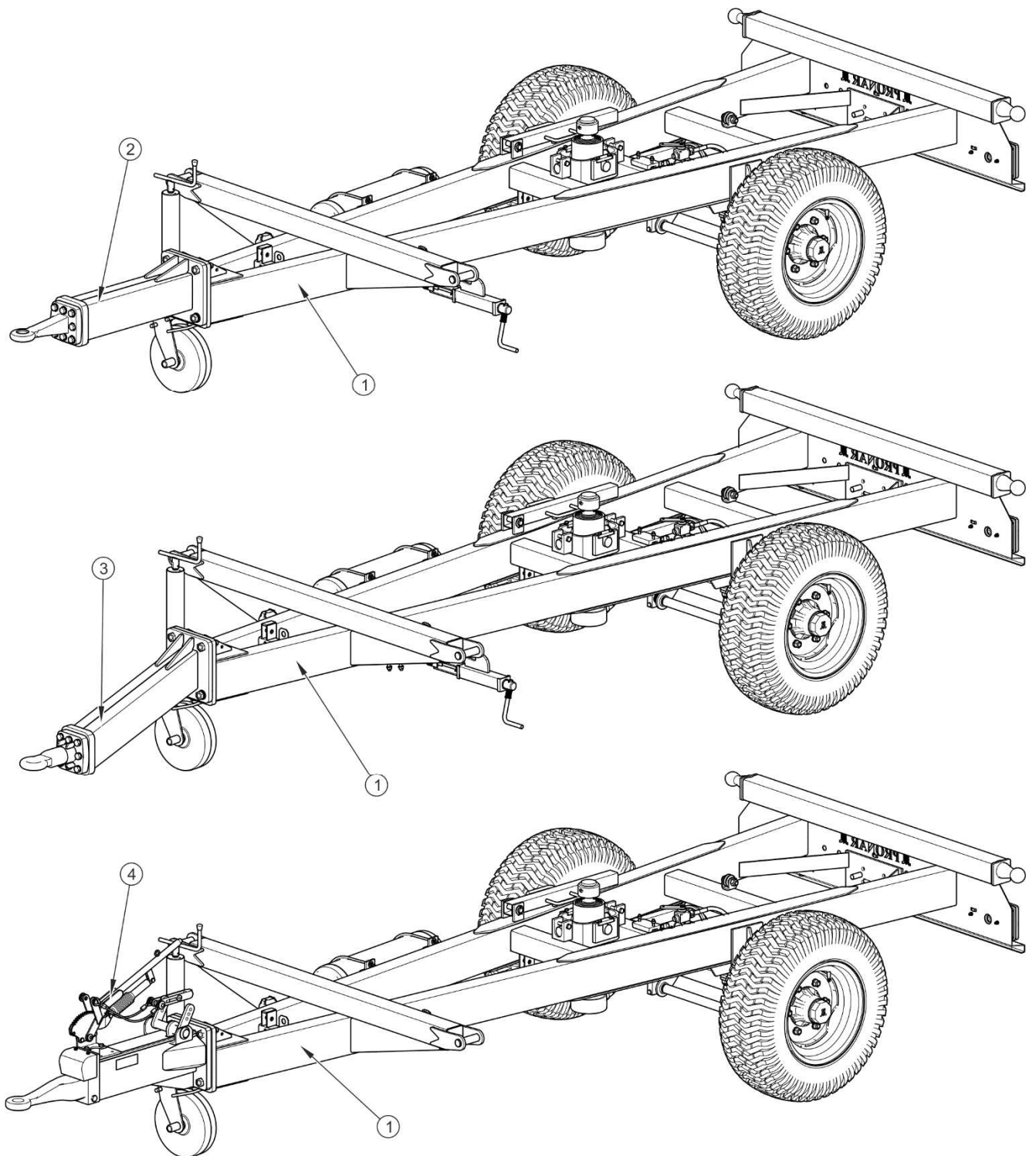

FIGURE 3.2 *Trailer chassis*

(1) lower frame, (2) drawbar for connecting with upper transport hitch (3) drawbar for connecting with lower transport hitch, (4) overrun drawbar

3.2.2 LOAD BOX

The trailer's load box consists of: upper frame (1) – figure (3.3) with welded steel floor, side walls (3) front wall (3) and rear wall (4). Side walls and rear wall can be opened in order to load/unload materials. The front wall and front wall extension can not be opened but they can be dismantled by removing them from proper trailer's sockets. Side walls are 500 mm high. The trailer can be additionally equipped with 500 mm high wall extensions made of profiled sheet metal.

The load box is mounted on sockets of the rear beam and front crossbar of the lower frame, see figure (3.1). The chosen tipping direction is achieved by positioning the pin in the appropriately profiled socket opening, the construction of which prevents their inappropriate placing by trailer operator.

Load box rear and side walls are secured using pins in front side locks and locks welded to rear stakes (5) of side housing. Side walls and side wall extensions in the front of the load box are closed by means of locks (4) – figure (3.4). The locks are equipped with protections preventing their accidental opening. The lower parts of the walls are locked using bolting hooks located in the left longitudinal beam and right longitudinal beam and also in the rear beam of the upper frame. Closing and opening the sides is performed using two levers (1) - figure (3.4), placed on the front beam and in the case of the rear side, using a lever (6) – figure (3.3), placed on the left side of the load box.

Wall extensions are secured in the same way as the load box walls. Upper pins of the wall extensions are secured in the front extension locks and locks of rear stakes (7). In the lower part, the closure is formed by pins and hinges (8) bolted to the wall brackets. All hinges (8) are equipped with pins with cotter pins preventing them from falling out.

An access ladder (2), available as optional equipment, is fixed to the front wall and front wall extension. Wheel chocks are placed next to the ladder (3) – figure (3.4).

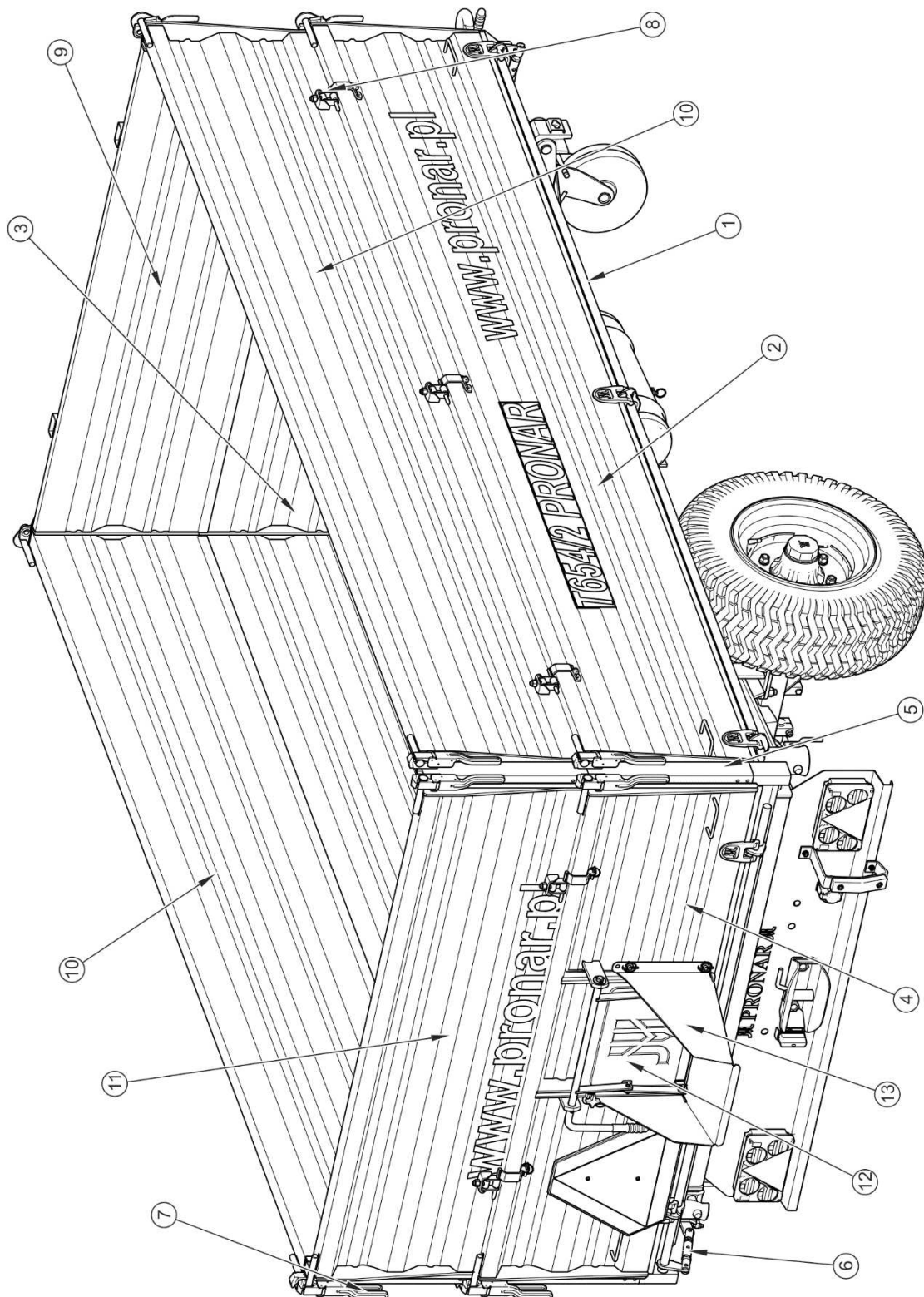

FIGURE 3.3 Load box – rear view

(1) upper frame, (2) side wall, (3) front wall, (4) rear wall, (5) rear stake of walls, (6) lever, (7) rear stake of wall extensions, (8) hinge pin, (9) front wall extension, (10) side wall extension, (11) rear wall extension, (12) chute slide gate, (13) chute

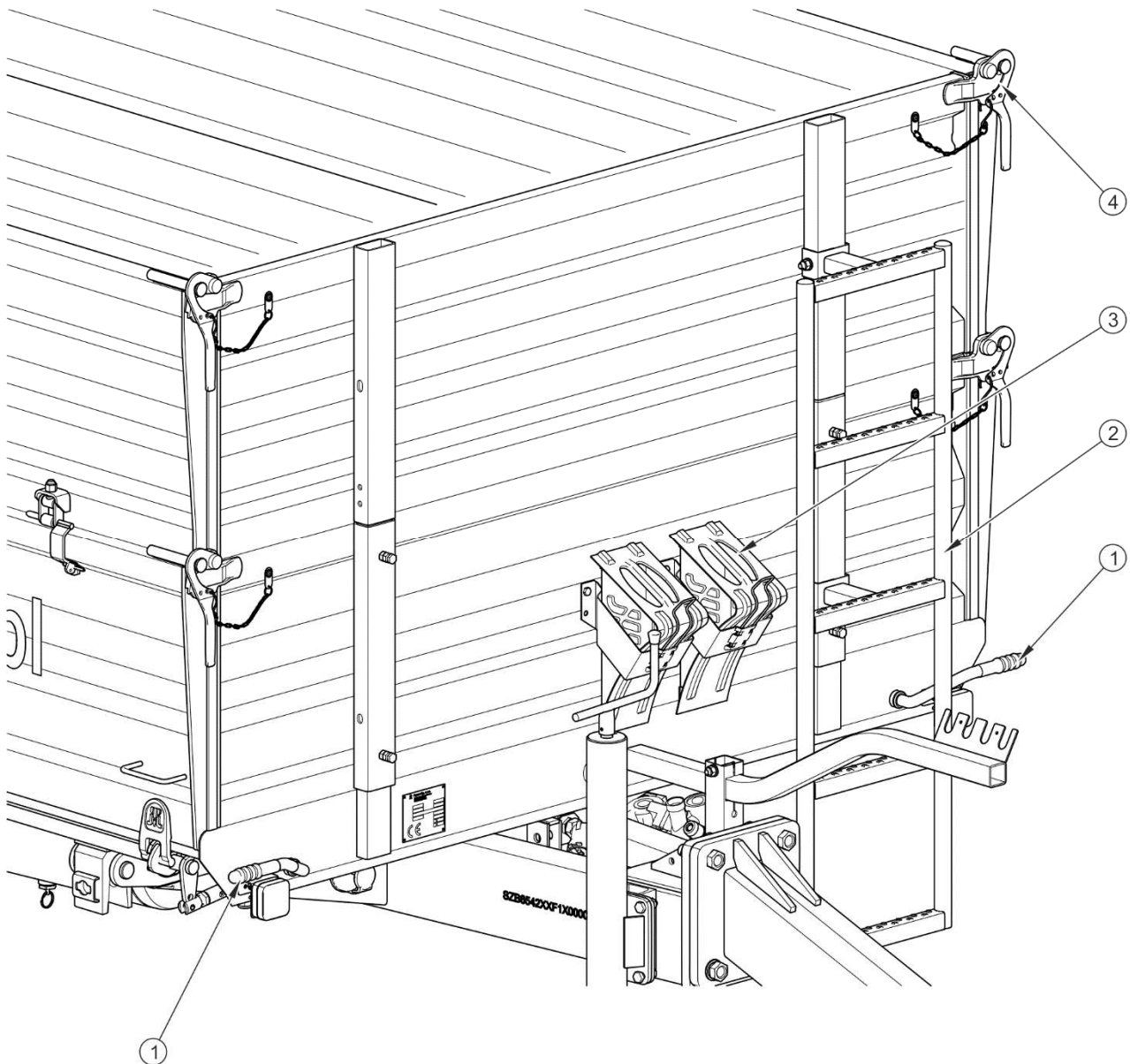

FIGURE 3.4 Load box

(1) front wall closing lever, (2) ladder, (3) wheel chocks, (4) left lock

In order to enable very precise unloading of loose materials there is a slide opening placed in the rear wall (1) – figure (3.5), which is raised using lever (2). When in upper position and also during transport the slide must be secured by tightening the locking screw (3). A chute for the trailer, secured under the lower edge of the slide opening (4) may be supplied as additional equipment.

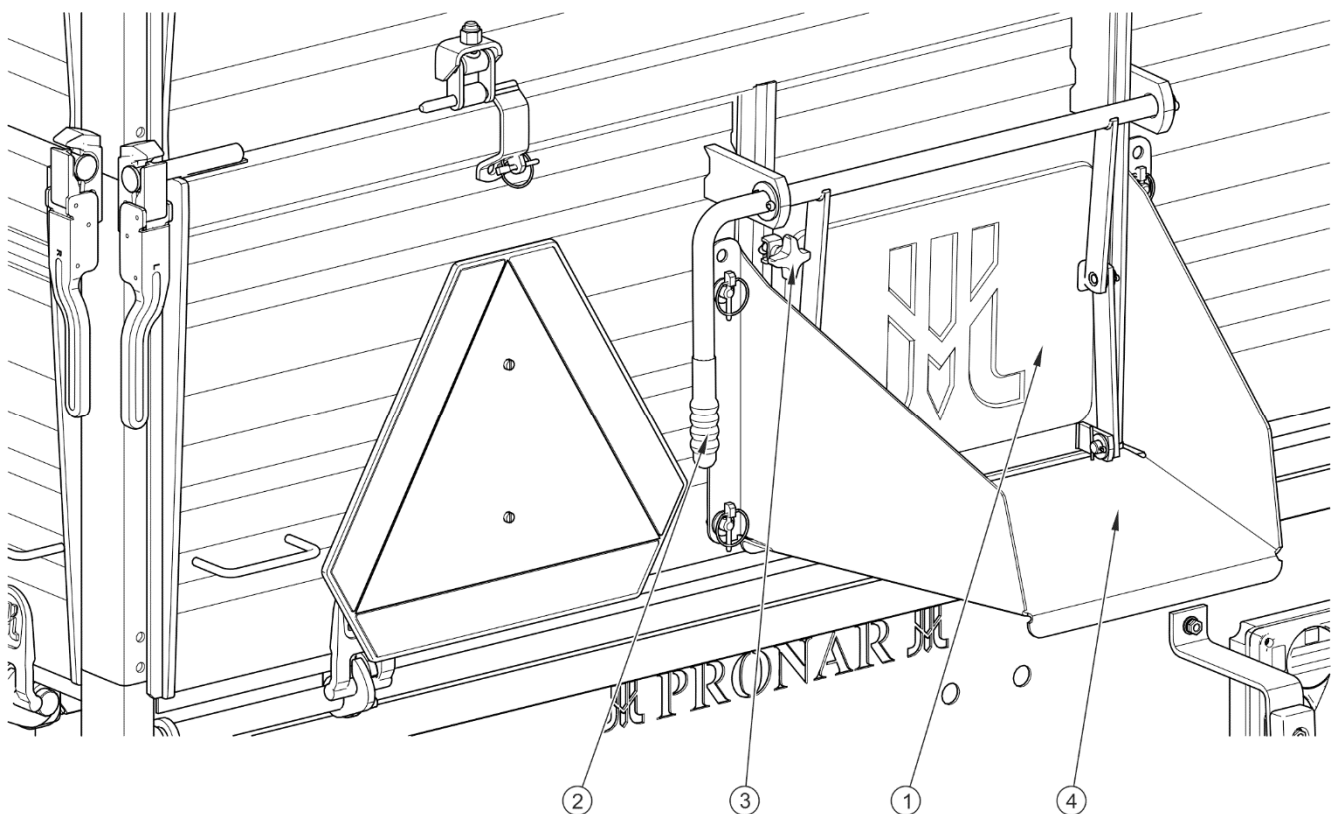

FIGURE 3.5 *Rear wall slide gate with lock and chute*

(1) slide gate, (2) lever, (3) locking screw, (4) chute

3.2.3 MAIN BRAKE

The trailer is equipped with one of four types of main brake:

- double conduit pneumatic brake system with three position regulator, figure (3.6),
- single conduit pneumatic system with three position regulator, figure (3.7),
- hydraulic brake system, figure (3.8),
- overrun brake, figure (3.9).

The main brake (pneumatic or hydraulic brake) is activated from the tractor driver's cab by depressing the brake pedal. The function of the control valve (2) - figure (3.6) and (3.7) is to activate the trailer's brakes simultaneously with the tractor's brakes. Furthermore, in case of an inadvertent disconnection of the conduit between the trailer and the tractor, the control valve will automatically activate trailer's brakes. Valve used in the system is equipped with a circuit causing the brakes to be applied when trailer is disconnected from the tractor. When

compressed air conduit is connected to the tractor, the device automatically applying the brakes now changes its position to allow normal brake operation.

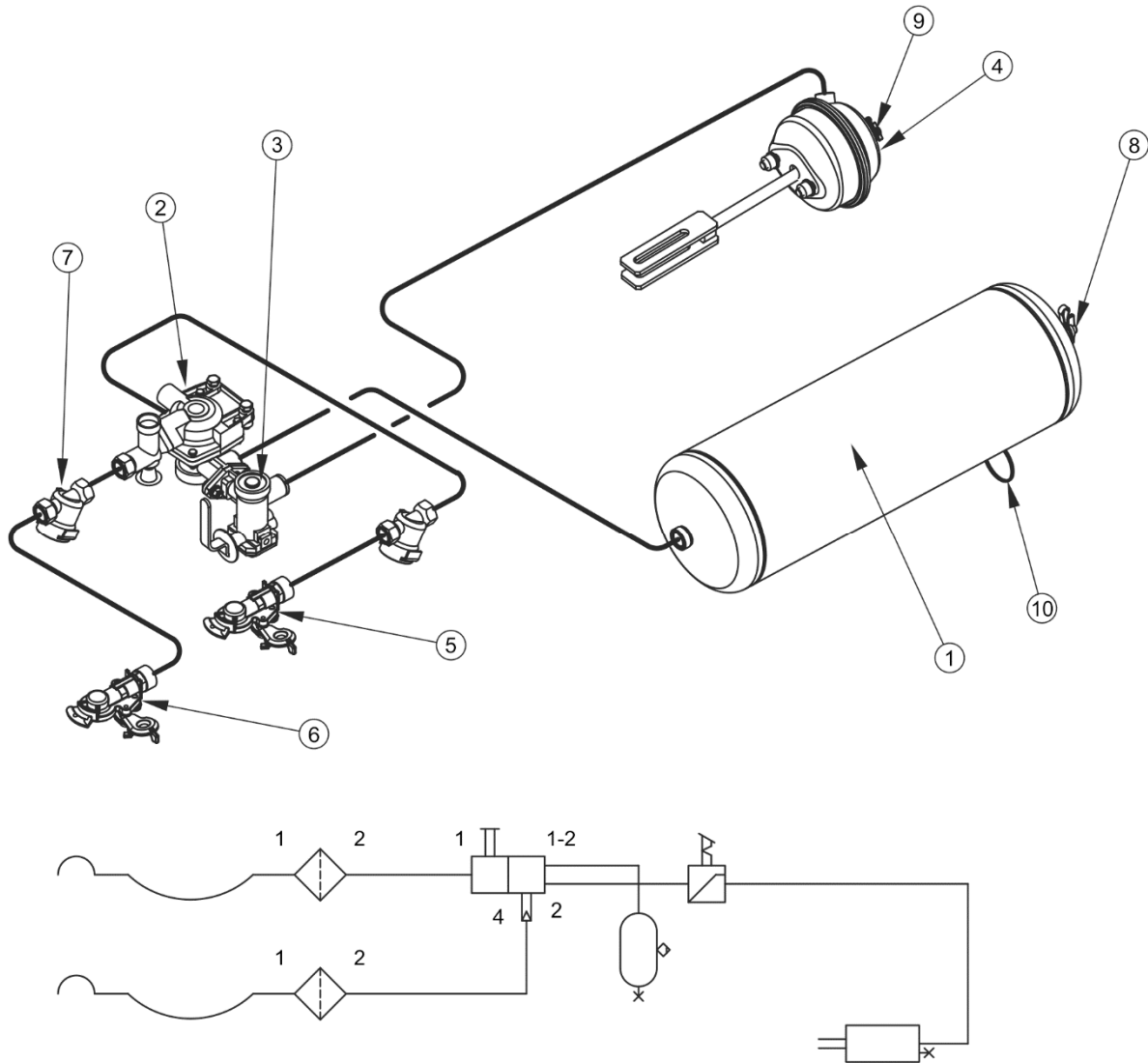

FIGURE 3.6 Design and diagram of the double conduit pneumatic brake system.

(1) air tank, (2) control valve, (3) braking force regulator, (4) pneumatic cylinder, (5) conduit connector (red), (6) conduit connector (yellow), (7) air filter, (8) air tank control connector, (9) pneumatic cylinder control connector, (10) drain valve

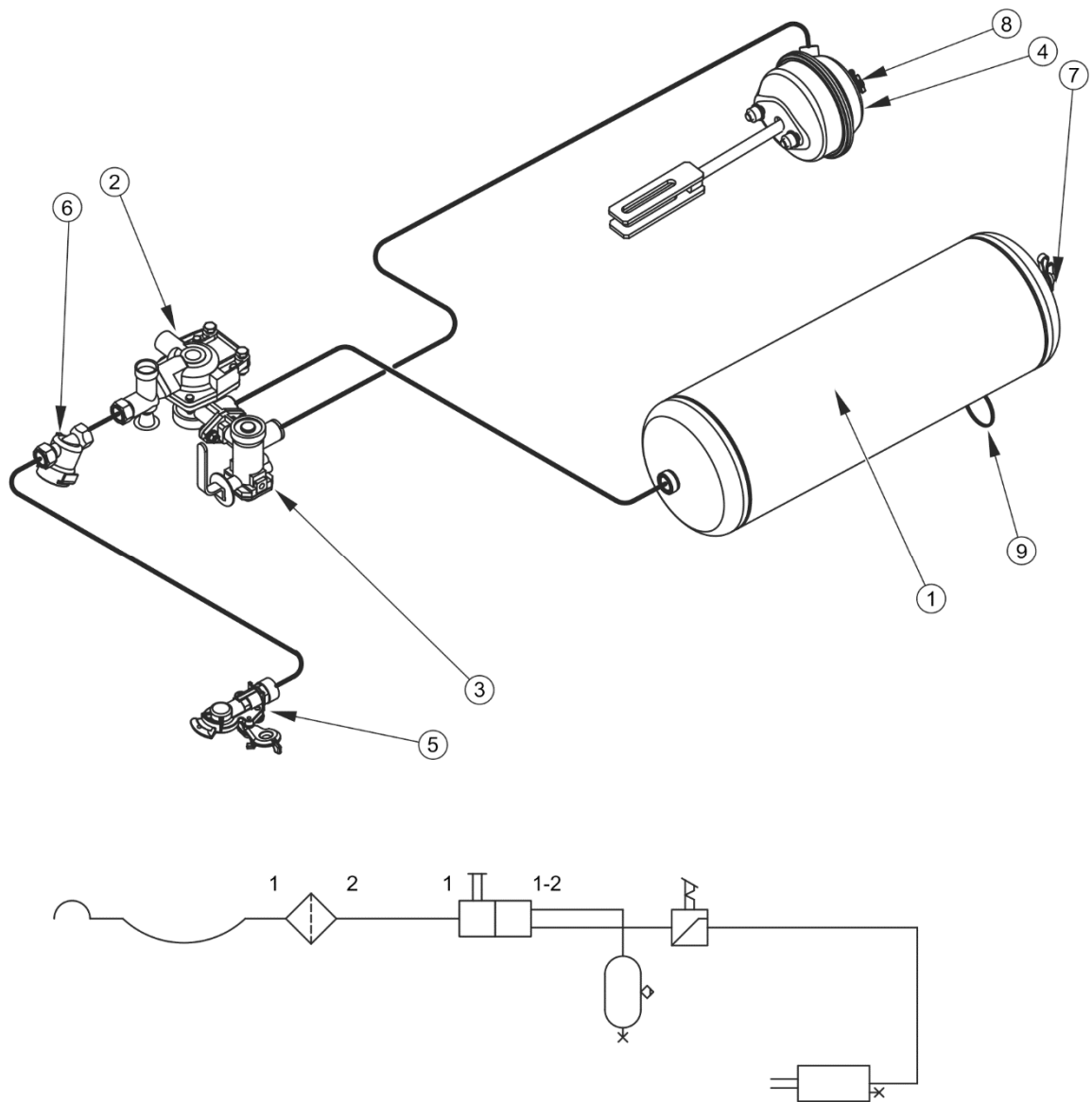

FIGURE 3.7 Design and diagram of the single conduit pneumatic brake system

(1) air tank, (2) control valve, (3) braking force regulator, (4) pneumatic cylinder, (5) conduit connection (black), (6) air filter, (7) air tank control connector, (8) pneumatic cylinder control connector, (9) drain valve

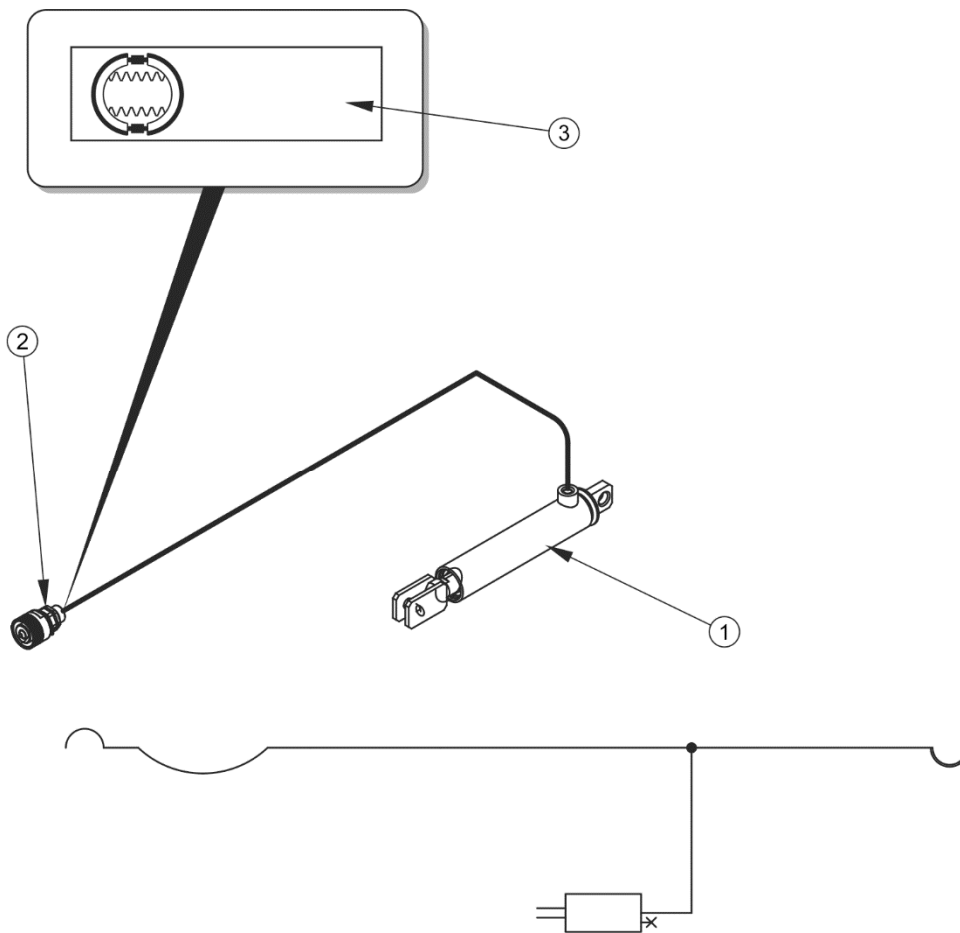

FIGURE 3.8 *Design and diagram of hydraulic braking system*

(1) hydraulic cylinder, (2) hydraulic quick-coupler, (3) information decal

The main hydraulic brake (available as optional equipment) is activated from the tractor driver's cab by depressing the brake pedal. Agricultural tractor equipped with suitable hydraulic system is required to operate the hydraulic braking system.

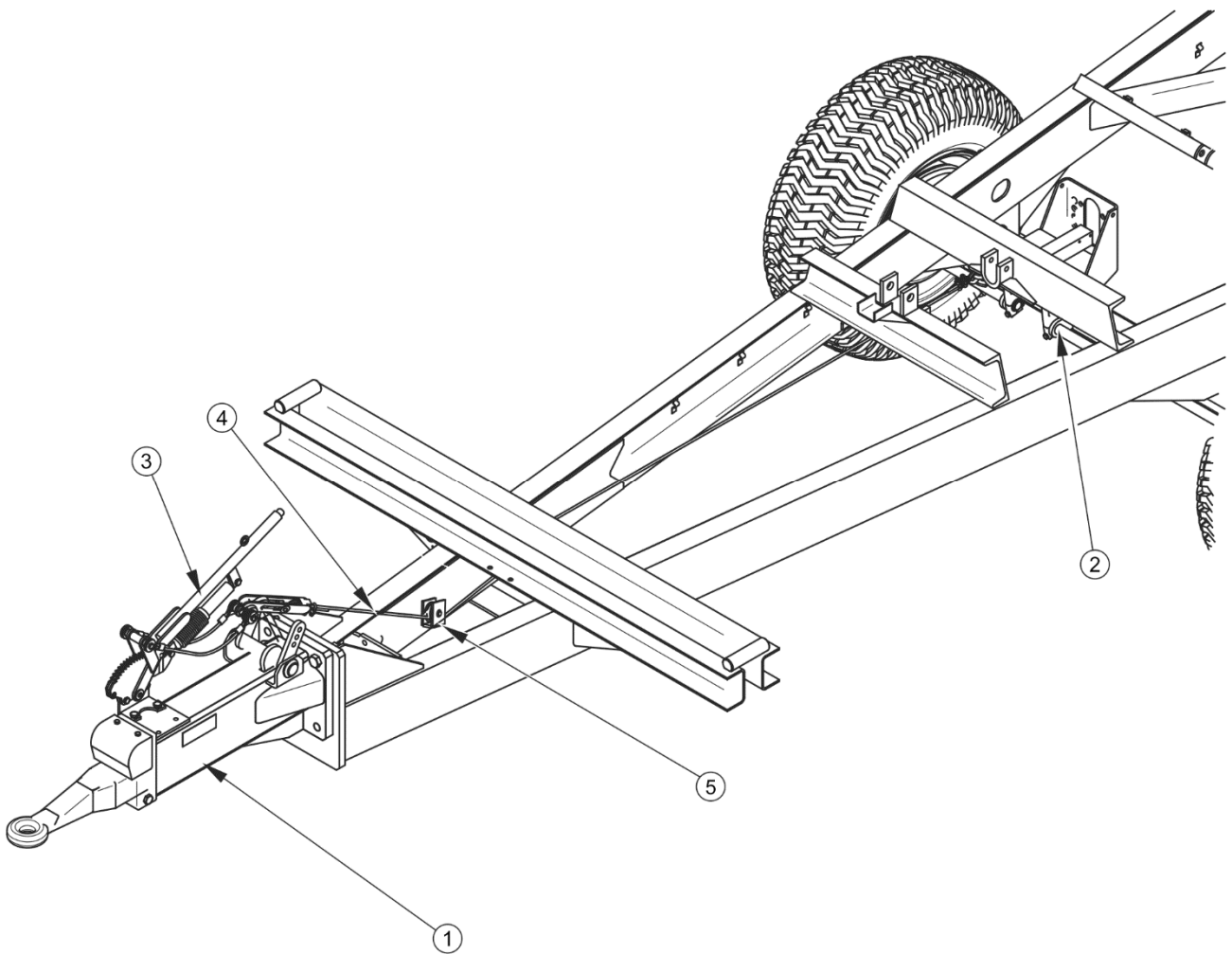

FIGURE 3.9 *Overrun brake*

(1) overrun drawbar, (2) wheel axle with overrun brake, (3) handbrake lever, (4) steel cable, (5) guide roller

Overrun brake system design is shown in figure (3.9). As standard, drawbar (1) with movable hitching eye is secured to the faceplate of the lower frame. Steel cable (4) connects the hitching eye with the axis with overrun brake. At the moment of activating the brake in the tractor, the trailer exerts pressure on the tractor hitch, as a result of which the drawbar pull rod moves in the body. Steel cables are connected with overrun drawbar levers and axle expander levers, which activate trailer brakes. Overrun axles or equipped with mechanism preventing wheel blocking while reversing trailer.

Three-step braking force regulator (2)- figure (3.10) adjusts braking force depending on setting. Switching to a suitable working mode is done manually by machine operator using

the lever (4) prior to moving off. Three working positions are available: A - "no load", B - "half load" and C - "full load".

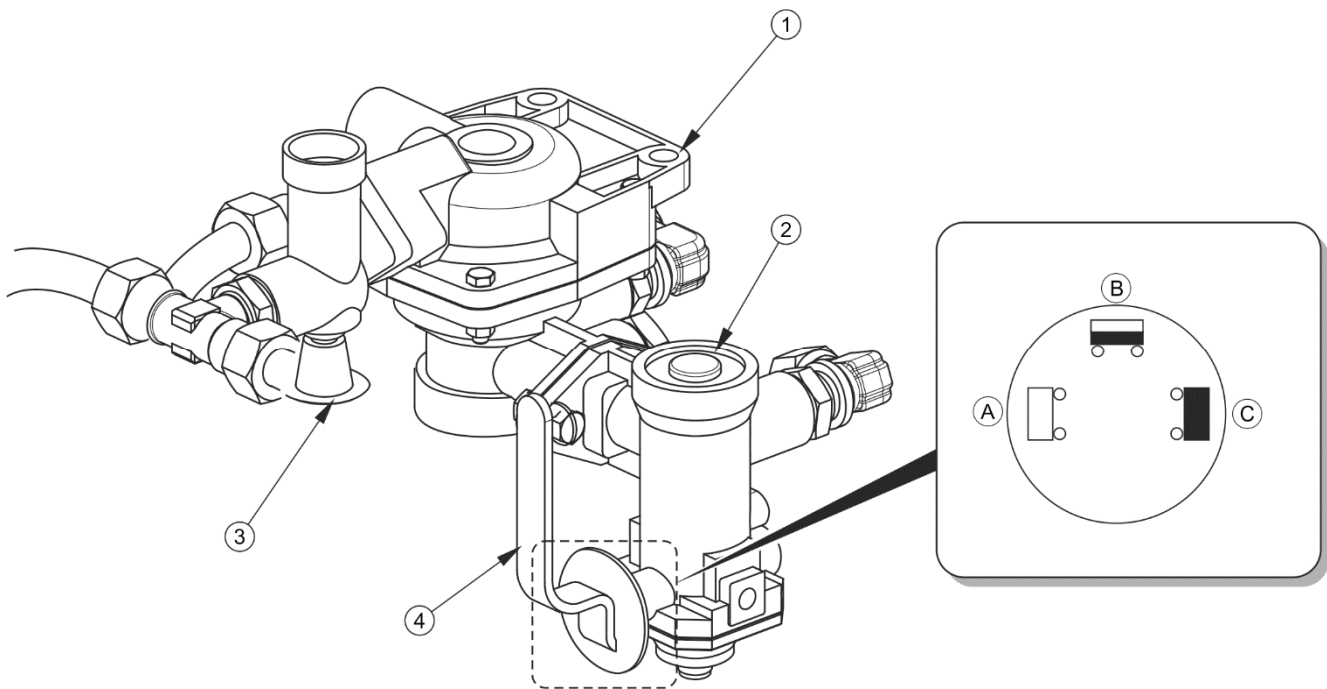

FIGURE 3.10 Control valve and braking force regulator

(1) control valve, (2) braking force regulator, (3) trailer parking brake release button, (4) work selection regulator lever, (A) position "NO LOAD", (B) position "HALF LOAD", (C) position "FULL LOAD"

3.2.4 HYDRAULIC TIPPING SYSTEM

Hydraulic tipping system, figure (3.11), is used for automatic unloading of trailer by tipping the load box to the rear or sideways. The hydraulic tipping system is supplied with oil from the tractor's hydraulic system. Hydraulic oil manifold of the tractor's external hydraulic system is used to control the load box tipping mechanism.

On the connection conduit, in the vicinity of plug (3), there is a decal (6) identifying the supply conduit of the hydraulic tipping system.



TIP

The hydraulic system of the trailer is filled with L-HL32 Lotos hydraulic oil.

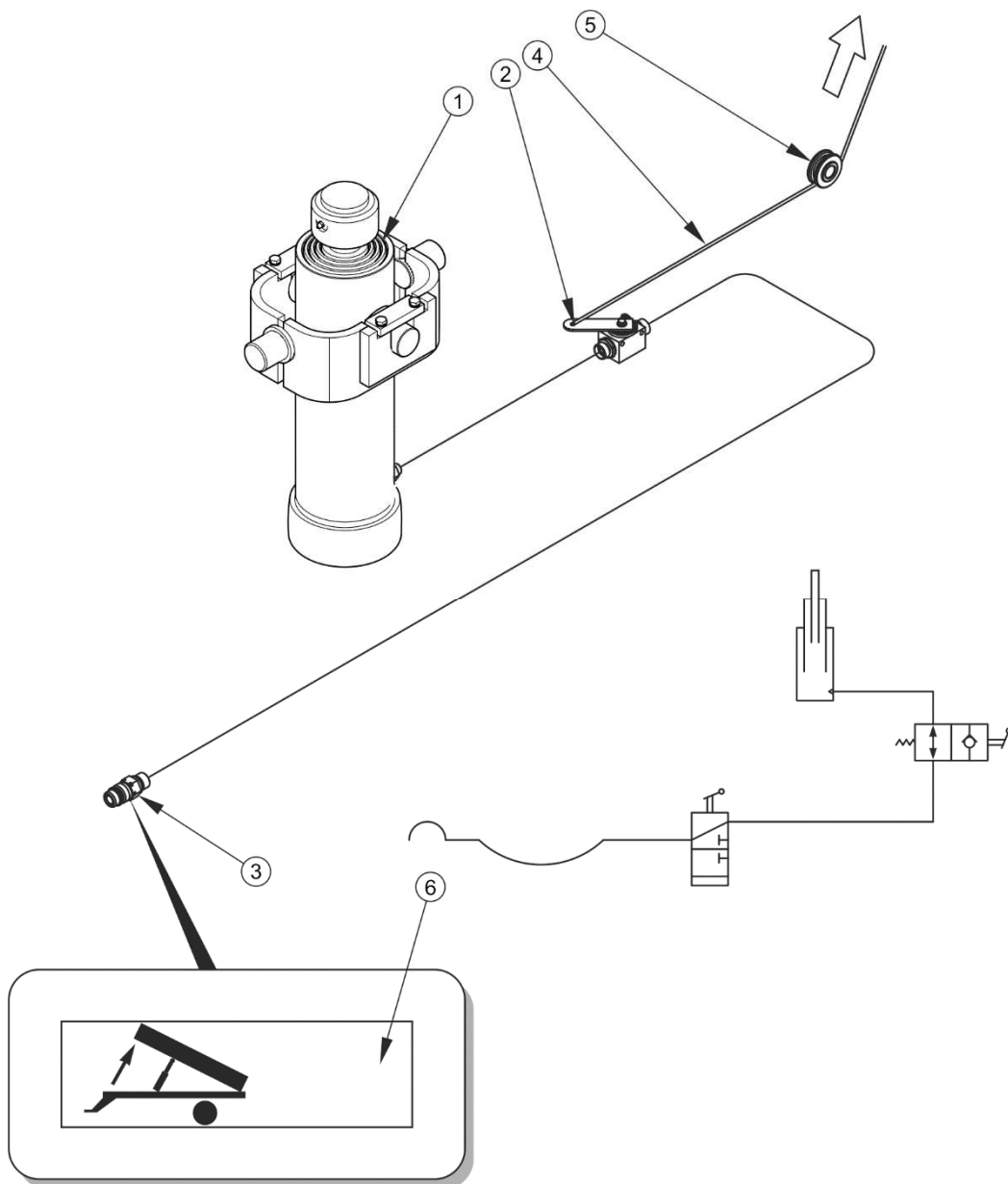

FIGURE 3.11 Hydraulic tipping system design and diagram

(1) telescopic cylinder, (2) cut-off valve, (3) quick coupler, (4) control cable, (5) guide roller, (6) information decal



ATTENTION

Cut-off valve (2) – figure (3.11) limits the tipping angle of the load box when tipped to the sides and to the rear. The length of the control cable (4) controlling this valve is factory adjusted by the Manufacturer and must not be changed when the trailer is used.

3.2.5 PARKING BRAKE

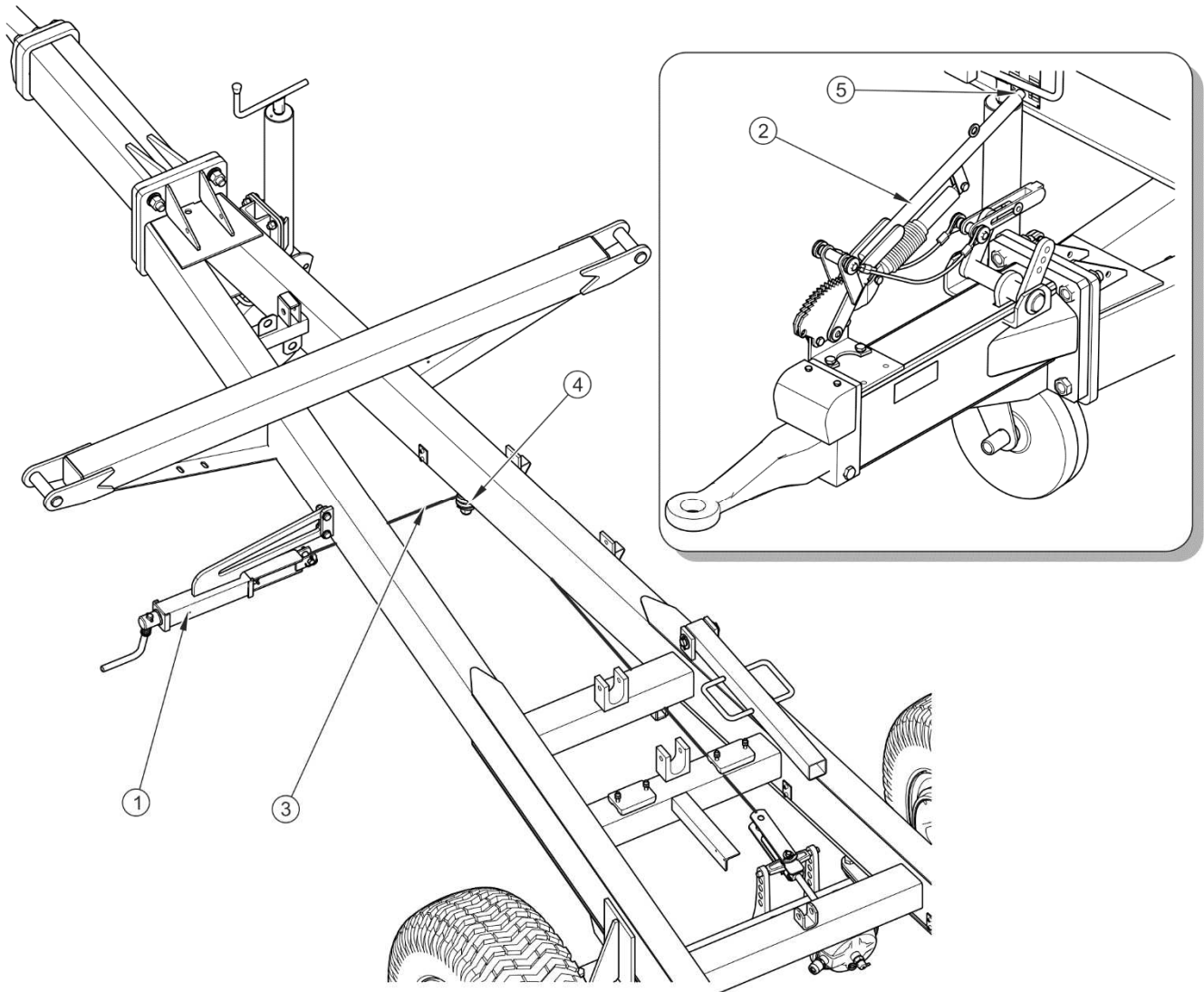

FIGURE 3.12 *Parking brake design*

(1) crank mechanism, (2) parking brake lever in overrun drawbar, (3) cable, (4) guide roller, (5) securing button

The parking brake is used to immobilise and prevent the trailer from moving while standing motionless. Two versions of parking brake are available. The main difference between the parking brake versions is the activating mechanism:

- parking brake operated by crank mechanism (1) – figure (3.12),
- lever operated parking brake (2) integrated with overrun drawbar,

In all versions of the brake, steel cable (3), guided by the roller (4), is connected with the expander arms and brake crank or lever mechanism. Tightening the cable causes tilting of the expander levers, which part the jaws of the brake shoes immobilising the trailer.

In case of parking brake with crank mechanism, cable tightening is achieved by turning the crank clockwise until resistance is felt. In parking brake of overrun drawbar, the cable is tensioned using lever (2) (button (5) must be pressed in order to release the brake).

3.2.6 LIGHTING SYSTEM

TABLE 3.2 *List of electrical component markings*

SYMBOL	FUNCTION
ZP	Rear right lamp assembly
ZL	Rear left lamp assembly
GP	Front seven pin socket
GT	Rear seven pin socket
OTP	Right license plate light
PP	Front right parking light
PL	Front left parking light

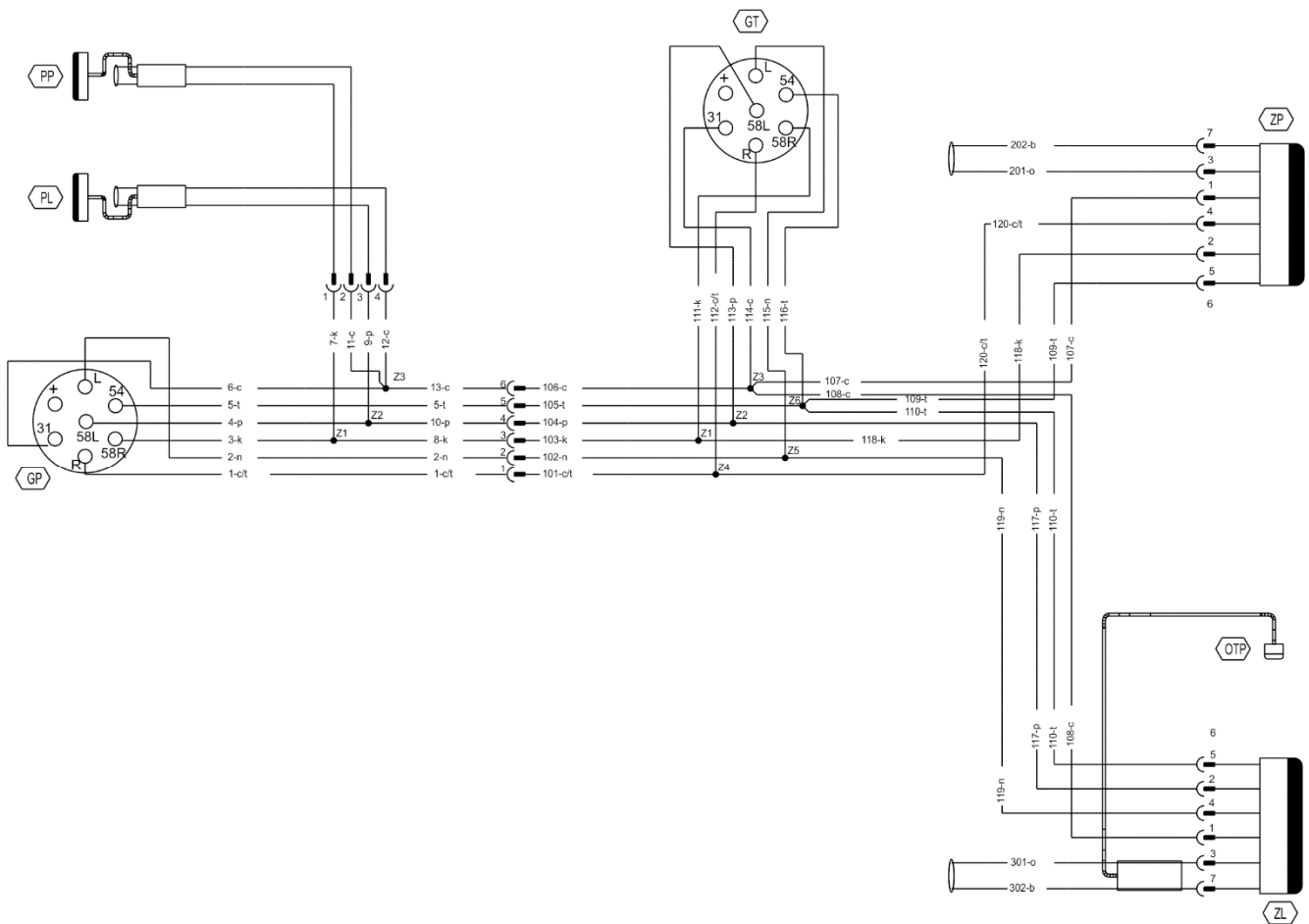

FIGURE 3.13 *Electrical system concept diagram*

Marking according to table (3.2)

The trailer electrical system is designed for supply from direct current source of 12 V. Connection of the trailer electrical system with the tractor should be made through an appropriate connection lead delivered with the new trailer.

Optionally, the trailer can be equipped with LED lighting system. A burnt out LED should be replaced with a new one.

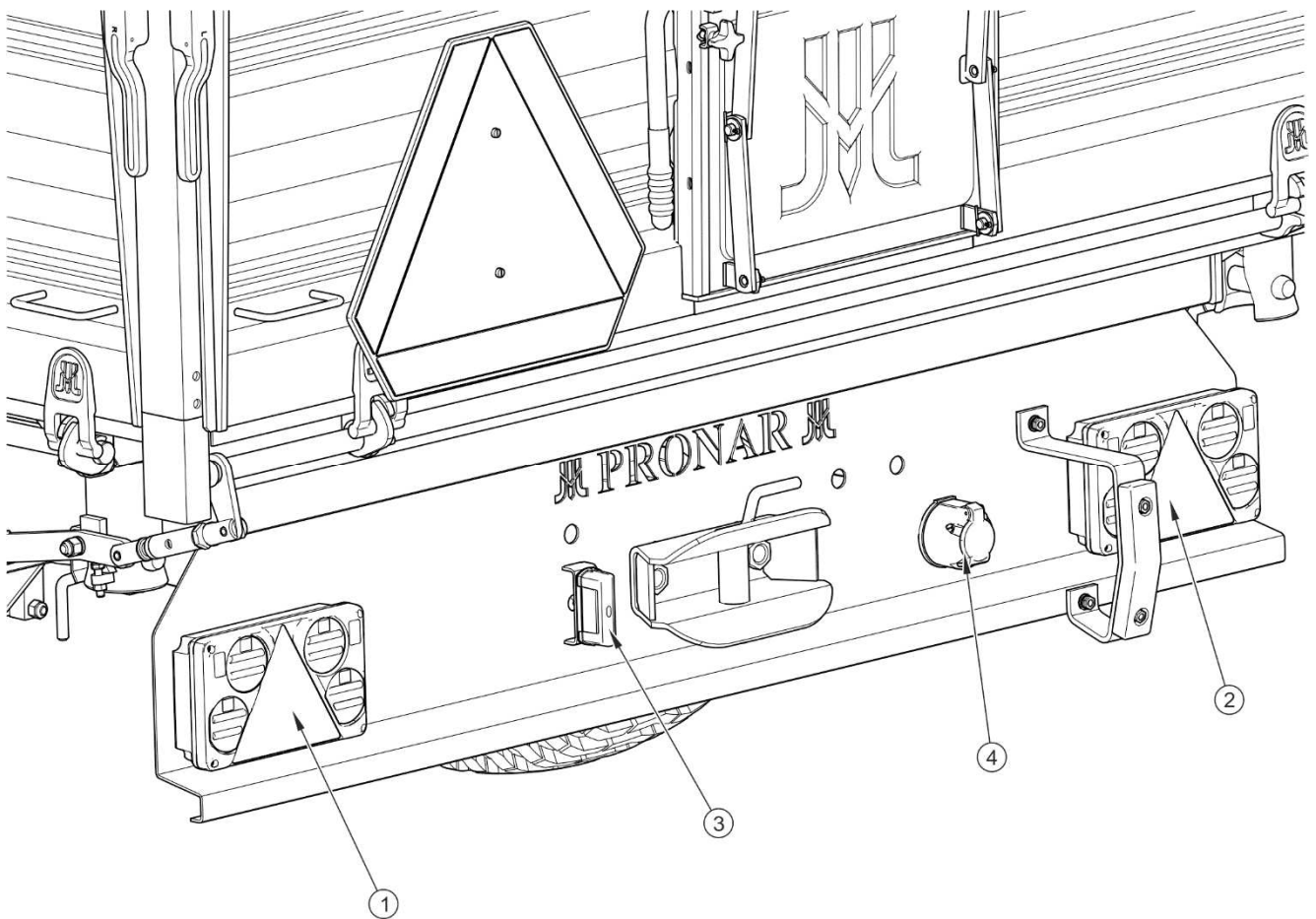

FIGURE 3.14 Arrangement of lighting system components – rear view

(1) rear left lamp assembly, (2) rear right lamp assembly, (3) license plate light, (4) rear 7-pin socket

TABLE 3.3 Marking of connections of X7P and GT sockets

MARKING	FUNCTION
31	Ground
+	Power supply +12V (not used)
L	Left indicator
54	STOP light
58L	Rear left parking light
58R	Rear right parking light
R	Right indicator

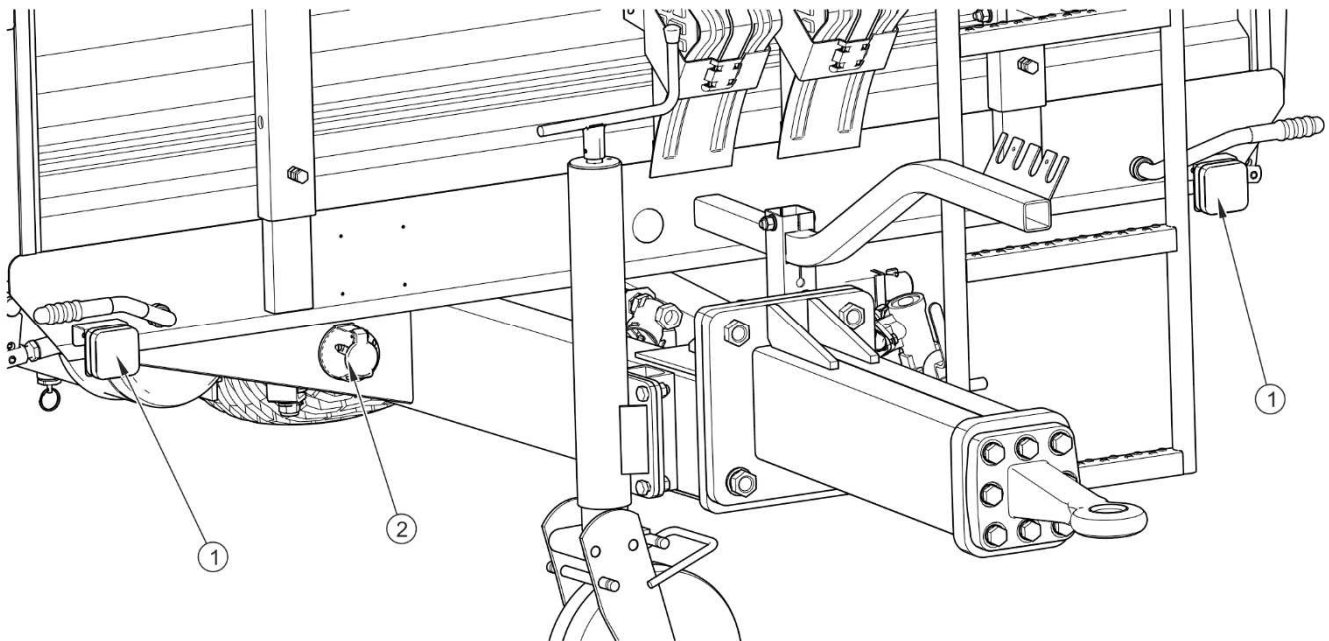

FIGURE 3.15 Arrangement of lighting system components – front view

(1) front parking light, (2) front 7-pin socket

SECTION

4

CORRECT USE

4.1 PREPARING FOR WORK BEFORE THE FIRST USE

4.1.1 CHECKING THE TRAILER AFTER DELIVERY

The manufacturer guarantees that the trailer is fully operational and has been checked according to quality control procedures and is ready for normal use. This does not release the user from an obligation to check the machine's condition after delivery and before first use. The machine is delivered to the user completely assembled.

Before commencing work, machine operator must inspect the technical condition of the trailer and prepare it for the first start-up. The user must carefully read this Operator's Manual and observe all recommendations, understand the design and the principle of machine operation.



ATTENTION

Before hitching to tractor and using the trailer, the user must carefully read this Operator's Manual and observe all recommendations.

External inspection

- ➔ Check completeness of machine (standard and optional equipment).
- ➔ Check condition of protective paint coat,
- ➔ Inspect trailer's individual components for mechanical damage resulting from incorrect transport (dents, piercing, bent or broken components).
- ➔ Check technical condition of tyres and tyre pressure.
- ➔ Check technical condition of elastic hydraulic conduits.
- ➔ Check technical condition of pneumatic conduits.
- ➔ Check that there are no hydraulic oil leaks.
- ➔ Check electric lamps.
- ➔ Check hydraulic cylinders for leaks of hydraulic oil.

4.1.2 PREPARING THE TRAILER FOR FIRST HITCHING TO TRACTOR

Preparation

- ➔ Check all the trailer's lubrication points, lubricate the machine as needed according to recommendations provided in section 5,
- ➔ Check if the nuts and bolts fixing the wheels are properly tightened.
- ➔ Drain air tank of the braking system.
- ➔ Ensure that pneumatic, hydraulic and electric connections in agricultural tractor are according to the requirements, if not the trailer should not be hitched to the tractor.
- ➔ Adjust the height of the drawbar or position of upper transport hitch. Check tightening of bolts securing drawbar hitch.

⇒ A detailed description can be found in section 5.

Test drive

If all the above checks have been performed and there is no doubt as to the trailer's good technical condition, it can be connected to tractor. Start the tractor, check all systems and conduct test run of trailer without load (no load in load box). It is recommended that the inspection is conducted by two people, one of which should always remain in the tractor cab. Test drive should be conducted according to the sequence shown below.



TIP

Operating activities: hitching to/unhitching from tractor, adjustment of draw bar position, tipping of load box etc. are described in detail in further parts of the Operator's Manual, in sections 4 and 5.

- ➔ Connect the trailer to appropriate hitch on agricultural tractor.
- ➔ Connect conduits of braking, electrical and hydraulic systems.
- ➔ Raise support to transport position.
- ➔ Switch on individual lights, check correct operation of electrical system.
- ➔ Conduct test tipping of load box backwards and sideways.

- ➔ When moving off check if the main brakes operate correctly.
- ➔ Perform test drive.

The trailer may be hitched only when all preparatory activities including inspection of technical condition have been completed satisfactorily. If during test run worrying symptoms occur such as:

- noise and abnormal sounds originating from the abrasion of moving elements of the trailer design,
- hydraulic oil leak,
- pressure drop in braking system,
- incorrect operation of hydraulic and/or pneumatic cylinders,

or other faults, find the cause of the problem. If a fault cannot be rectified or the repair could void the warranty, please contact the dealer for additional clarifications or to perform repair.

DANGER



Careless and improper use and operation of the trailer, and non-compliance with the recommendations given in this operator's manual is dangerous to your health.

The trailer must never be used by persons, who are not authorised to drive agricultural tractors, including children and people under the influence of alcohol or other drugs.

Non-compliance with the safety rules of this Operator's Manual can be dangerous to the health and life of the operator and others.

After completion of test drive check tightness of wheel nuts.

4.2 HITCHING AND UNHITCHING THE TRAILER FROM TRACTOR

Ensure that pneumatic, hydraulic and electric connections and the hitch of agricultural tractor are according to the Manufacturer's requirements, if not the trailer should not be hitched to the tractor.

In order to hitch the trailer to the tractor, perform the actions below in the sequence presented. Machine must be immobilised by parking brake.

Hitching to tractor

- ➔ Immobilise trailer with parking brake.
 - ⇒ Pull brake mechanism clockwise until resistance is felt – if trailer is equipped with standard parking brake.
 - ⇒ Pull parking brake lever until resistance is felt – if trailer is equipped with overrun brake.
- ➔ Position agricultural tractor directly in front of drawbar eye.
- ➔ Set the drawbar eye with the aid of the support at such a height that it is possible to hitch the machine.
- ➔ Reverse tractor, hitch trailer, check coupling lock protecting machine against accidental unhitching.
 - ⇒ If the agricultural tractor is equipped with an automatic coupler, ensure that the hitching operation is completed and that drawbar eye is secured.
- ➔ Turn off tractor engine. Ensure that unauthorised persons do not have access to the tractor cab.
- ➔ Connect pneumatic system conduits (applies to double conduit systems):
 - ⇒ Connect pneumatic conduit marked yellow with yellow socket in tractor.
 - ⇒ Connect pneumatic conduit marked red with red socket in tractor.

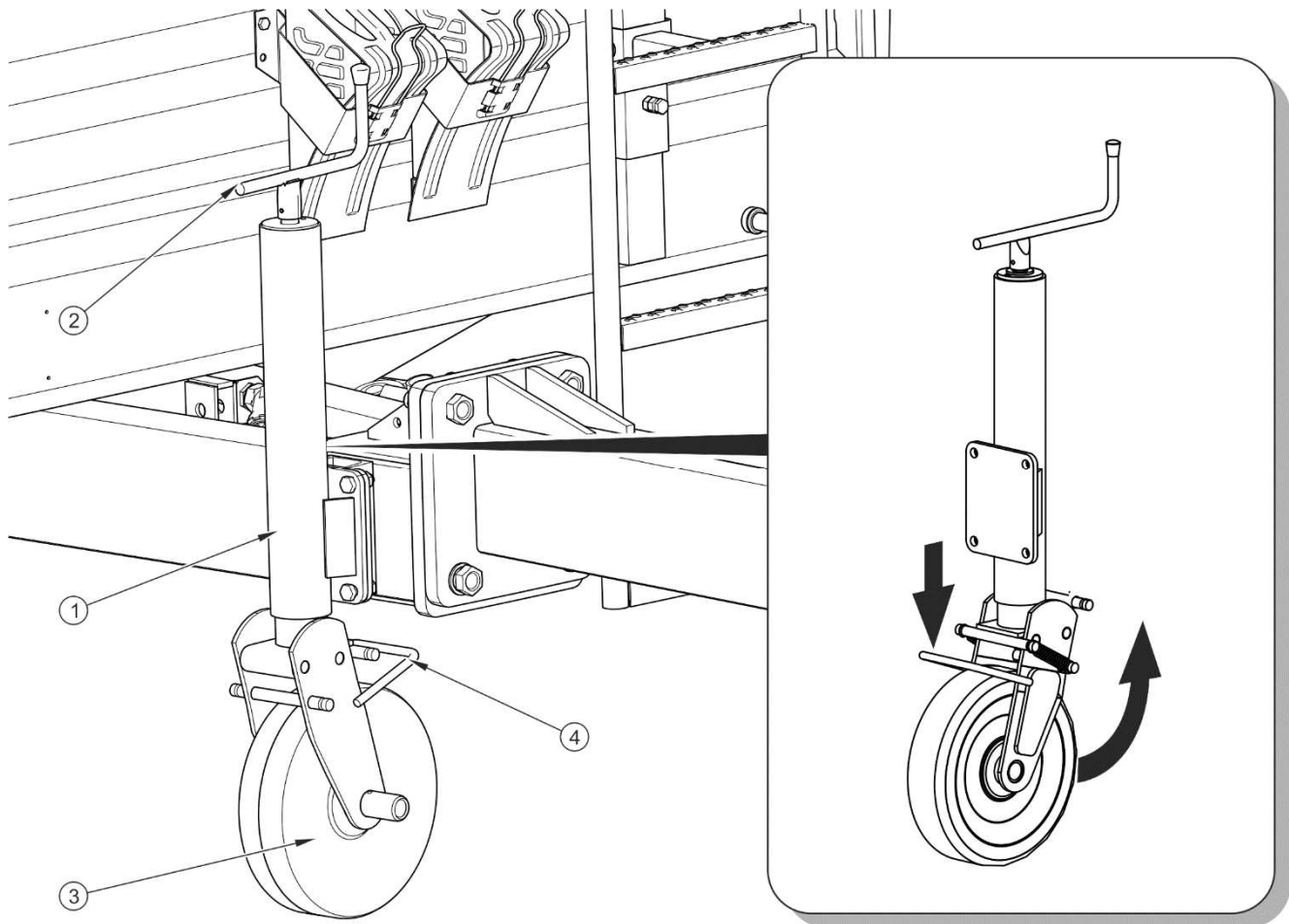

FIGURE 4.1 *Trailer support*

(1) straight support with wheel, (2) cylinder, (3), (4) conduits, (5), (6) information decals

- ➔ Connect pneumatic system conduits (applies to single conduit pneumatic system):
 - ⇒ Connect pneumatic conduit marked black with black socket in tractor.
- ➔ Connect hydraulic braking system conduit (applies to trailer version with hydraulic braking system).
 - ⇒ Hydraulic braking system conduit is marked with information decal (9) – table (2.1) chapter 2.
- ➔ Connect hydraulic tipping system conduits.
 - ⇒ Hydraulic tipping system conduit is marked with information decal (10) – table (2.1).

- ➔ Connect main lead supplying electrical lighting system.
- ➔ Turning crank (2) – figure (4.1) raise support wheel.
- ➔ Press support pedal (4) and holding wheel with hand (3) place it in transport position.

DANGER



When hitching, there must be nobody between the trailer and the tractor. When hitching the machine, tractor driver must exercise caution and make sure that nobody is present in the hazard zone.

When connecting the hydraulic conduits to the tractor, make sure that the hydraulic system of the tractor and the hydraulic system of the trailer are not under pressure.

Ensure sufficient visibility during hitching.

Exercise particular caution while folding the support - danger of severing limbs.

After completion of hitching check the security of the hitching pin.

ATTENTION



Ensure compatibility of oils in tractor hydraulic system and in the trailer hydraulic system.

Trailer may only be hitched to a tractor, which has the appropriate hitch, connection sockets for braking, hydraulic and electrical systems, and hydraulic oil in both machines is the same type and may be mixed.

When hitching is completed, secure the electrical leads and hydraulic and braking system conduits in such a way that they do not become entangled in tractor's moving parts and are not at the risk of breaking or being severed when making turns.

During connection of braking system conduits (pneumatic double conduit) the correct sequence of conduit connection is very important. First connect the yellow connector to yellow socket in the tractor and only then connect the red connector to the red socket in the tractor. Once the 2nd conduit is connected, the braking system will switch to normal mode of operation (disconnection or interruption of the conduits causes the trailer's braking system control valve to automatically apply brakes). Conduits are marked with coloured protective covers, which identify the appropriate system conduit.

Unhitching the trailer

In order to unhitch the trailer from the tractor follow these steps.

- ➔ Immobilise tractor and trailer with parking brake.
- ➔ Turn off tractor engine. Ensure that unauthorised persons do not have access to the tractor cab.
- ➔ Return support wheel to parking position.
- ➔ Turning crank, set the drawbar eye at such a height that one may safely unhitch the trailer.
- ➔ Disconnect hydraulic tipping system conduit from tractor.
- ➔ Disconnect electric lead.
- ➔ Disconnect pneumatic system conduits (applies to double conduit pneumatic system).
 - ⇒ Disconnect pneumatic conduit marked red.
 - ⇒ Disconnect pneumatic conduit marked yellow.
- ➔ Disconnect pneumatic system conduits (applies to single conduit pneumatic system).
 - ⇒ Disconnect pneumatic conduit marked black.
- ➔ Disconnect hydraulic braking system conduits (applies to trailer version with hydraulic braking system).
 - ⇒ Disconnect the hydraulic braking system conduit that is marked with information decal (9) – table (2.1) section 2.
- ➔ Protect conduit ends with covers. Place conduit plugs in appropriate sockets.
- ➔ Place chocks under trailer wheel.
 - ⇒ Wheel chocks must be so placed that one is in front of the wheel and the second is behind the wheel - see section 2.
- ➔ Release tractor hitch and disconnect trailer drawbar from tractor hitch and drive tractor away.

DANGER

Exercise caution when unhitching the trailer from the tractor. Ensure good visibility. Unless it is necessary, do not go between tractor and trailer.

Before disconnecting conduits and drawbar eye, close tractor cab and secure it against access by unauthorised persons. Turn off tractor's engine.

Do not park a loaded trailer, which is disconnected from the tractor and resting on the parking stand wheel.

4.3 HITCHING AND UNHITCHING THE SECOND TRAILER

A second trailer may only be hitched if it is a machine built on a dual axle chassis and if it fulfils all the requirements specified in section 1.

Hitching the second trailer to the tractor - trailer unit requires experience in driving an agricultural tractor with a trailer. While hitching the second trailer, it is recommended to use the help of another person to guide the tractor driver.

Hitching the second trailer

- ➔ Position the tractor with the first trailer hitched directly in front of the second trailer's drawbar.
- ➔ Immobilise the second trailer with parking brake.
- ➔ Adjust the height of the drawbar of the second trailer in such a manner to enable coupling the machines.
- ➔ Remove cotter pin securing pin and take out hitch pin (2) in the first trailer - figure (4.2).
- ➔ Reversing tractor, drive the rear hitch of the first trailer onto the drawbar of the second trailer.
- ➔ Insert drawbar pin and securing cotter pin.
- ➔ Connect conduits of pneumatic, hydraulic and electrical systems according to instructions contained in section (4.2)

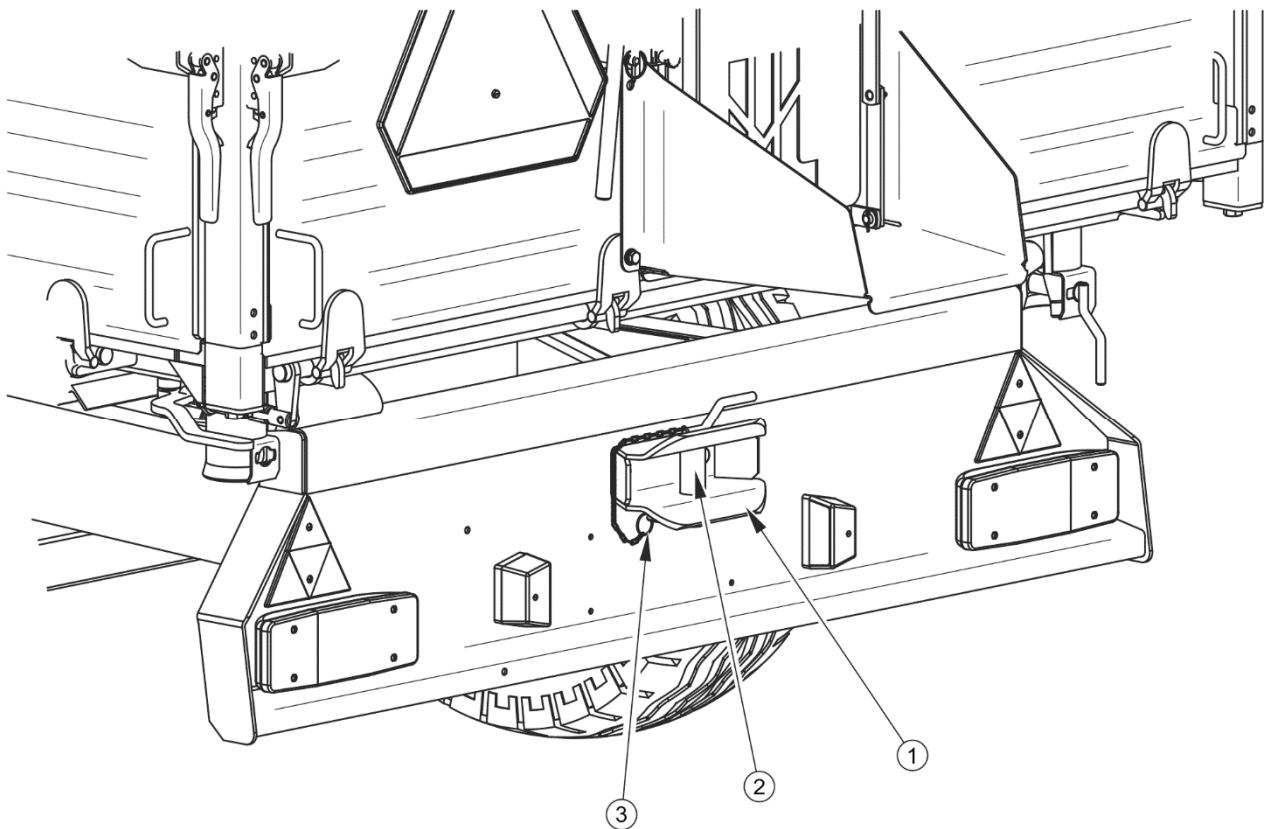

FIGURE 4.2 *Rear hitch*

(1) *hitch body*, (2) *hitch pin*, (3) *chain with linchpin securing pin*

Unhitching the second trailer

- ➔ Immobilise tractor and trailers with parking brake.
- ➔ Turn off tractor engine. Ensure that unauthorised persons do not have access to the tractor cab.
- ➔ Disconnect conduits of pneumatic, hydraulic and electrical systems according to instructions contained in section (4.2)
- ➔ Unlock the pin of the hitch of the first trailer. Remove the pin and drive tractor away.



DANGER

The person assisting in coupling the second trailer must stand in such a place as to be visible to the tractor driver at all times. Be especially careful and keep safe distance from danger zones.

ATTENTION

Do NOT hitch a second trailer constructed on any chassis except dual axle chassis.

The rear manual hitch is designed only for towing a second trailer whose permissible gross weight does not exceed 6 100 kg.

Do not hitch the second trailer if it is equipped with overrun brake.

4.4 LOADING AND SECURING LOAD

4.4.1 GENERAL INFORMATION ABOUT LOADING

Before loading, make certain that the load box walls and chute slide gate are properly closed and secured. The trailer must be positioned to travel forwards and hitched to the tractor. Loading should only take place, when trailer is placed on flat level surface and hitched to tractor.

Regardless of the type of load carried, the user is obliged to secure it in such a manner that the load is unable to spread and cause contamination of the road. If this is impossible, do NOT transport this type of load.

Materials, which in contact with painted or steel surfaces may cause damage, should be transported in sealed packaging (bags, boxes, barrels, etc.). After unloading, the load box should be thoroughly cleaned with a strong jet of water.

If the transported materials exert high local pressure on the load box platform it should be protected against damage using thick planks, plywood or other materials of similar properties.

When loading goods on pallets pay special attention to load distribution on the platform. Pallets must be secured against the displacement on the platform. Pallets must not be stacked in layers.

ATTENTION

Always aim at distributing the load uniformly in the load box.

Do NOT exceed the trailer's maximum carrying capacity.

Due to various densities of materials, the use of the total load box capacity may lead to exceeding permissible carrying capacity of the trailer. Guideline specific weight of selected materials is shown in table (4.1). Take care not to overload the machine. Loading should be carried out by a person experienced in this type of work and having appropriate authorisation for operating equipment (if required).

TABLE 4.1 *Guideline weights by volume of selected loads*

TYPE OF MATERIAL	WEIGHT BY VOLUME KG/M ³
Root crops: raw potatoes steamed crushed potatoes dried potatoes sugar beet - roots fodder beet - roots	700 - 820 850 - 950 130 - 150 560 - 720 500 - 700
Organic fertilisers: old manure mature manure fresh manure compost dry peat	700 - 800 800 - 900 700 - 750 950 – 1,100 500 - 600
Mineral fertilisers: ammonium sulphate potash salt super phosphate basic slag phosphate potassium sulphate kainite milled lime fertiliser	800 - 850 1,100 – 1,200 850 – 1,440 2,000 – 2,300 1,200 – 1,300 1,050 – 1,440 1,250 - 1,300
Building materials: cement dry sand wet sand	1,200 – 1,300 1,350 – 1,650 1,700 – 2,050

TYPE OF MATERIAL	WEIGHT BY VOLUME KG/M ³
solid bricks	1,500 – 2,100
hollow bricks	1,000 – 1,200
stones	1,500 – 2,200
soft wood	300 - 450
hard sawn timber	500 - 600
impregnated timber	600 - 800
steel structures	700 – 7,000
milled burnt lime	700 - 800
cinders	650 - 750
gravel	1,600 – 1,800
Straw litter and bulk feeds	
meadow hay dried in the swath	10 - 18
hay wilted in the swath	15 - 25
hay in gathering trailer (dry wilted)	50 - 80
wilted cut hay	60 - 70
dry baled hay	120 - 150
wilted baled hay	200 - 290
stored dry hay	50 - 90
stored cut hay	90 - 150
clover (lucerne) wilted in the swath	20 - 25
clover (lucerne) cut wilted on trailer	110 - 160
clover (lucerne) wilted on gathering trailer	60 - 100
dry stored clover	40 - 60
cut dry stored clover	80 - 140
dry straw in round bales	8 - 15
damp straw in round bales	15 - 20
cut damp straw in bulk trailer	50 - 80
cut dry straw in bulk trailer	20 - 40
cut dry straw in gathering trailer	50 - 90
cut dry straw in stack	40 - 100
baled straw (lightly crushed)	80 - 90
baled straw (heavily crushed)	110 - 150

TYPE OF MATERIAL	WEIGHT BY VOLUME KG/M ³
cut cereal mass in bulk trailer	35 - 75
cut cereal mass in gathering trailer	60 - 100
green fodder in swath	28 - 35
cut green fodder in bulk trailer	150 - 400
green fodder in gathering trailer	120 - 270
fresh beet leaves	140 - 160
cut fresh beet leaves	350 - 400
beet leaves in gathering trailer	180 - 250
Concentrated feeds and mixed feeds:	
stored chaff	200 - 225
pressed cake	880 – 1,000
milled dry feed	170 - 185
mixed feeds	450 - 650
mineral mixtures	1,100 – 1,300
ground oats	380 - 410
wet sugar beet pulp	830-1 000
pressed sugar beet pulp	750 - 800
dry sugar beet pulp	350 - 400
bran	320 - 600
bone meal	700 – 1,000
pasture salt ⁽¹⁾	1,100 – 1,200
molasses	1,350 – 1,450
silage (pit silo)	650 – 1,050
hay silage (tower silo)	550 - 750
Seeds and grains:	
beans	750 - 850
mustard	600 - 700
peas	650 - 750
lentils	750 - 860
runner beans	780 - 870
barley	600 - 750
clover	700 - 800

TYPE OF MATERIAL	WEIGHT BY VOLUME KG/M ³
grass	360 - 500
maize	700 - 850
wheat	720 - 830
oil seed rape	600 - 750
linseed	640 - 750
lupins	700 - 800
oats	400 - 530
lucerne	760 - 800
rye	640 - 760
Others:	
dry soil	1,300 – 1,400
wet soil	1,900 – 2,100
fresh peat	700 - 850
garden soil	250 - 350

Source: "Technology of machine work in agriculture", PWN, Warszawa 1985

ATTENTION



The trailer is designed for transport of harvested crops and agricultural products (loose and bulky). It is permissible to transport other loads (timber, building materials packed loads), on the condition of securing the load box against damage (abrasion of paint covering, corrosion etc.).

DANGER



Load on trailer must be secured against moving or contaminating road during travel. If it is impossible to properly secure the load, do NOT transport this type of material.

During loading the trailer the drawbar eye and the tractor hitch are subjected to great vertical loading.

Loose bulk material

Loading bulk materials is normally conducted with the use of loaders or conveyors and possibly loading manually. On completion of loading, the load should be evenly spread over the whole surface of the load box.

Oilseed rape or seeds of other plants of very small size or powder materials can be transported provided the load box is properly sealed in places where gaps are bigger than the seed diameter or other carried material. Profiled rubber seals, silicone sealers, plastic wrap, rope or textile materials are recommended materials to provide sealing of the load box.

Some bulk loads (e.g. building materials, such as gravel or slag) may cause more rapid damage to paintwork.

Loads of pieces or solid lumps

Loads of pieces or solid lumps are generally hard materials of significantly greater dimensions than bulk loads (stones, coal, bricks and ballast). Without prior preparation of the load box, these materials may cause indentation of the floor or sidewalls and abrasion of paintwork. In order to protect it, lay thick plywood, hard particle board, thick planks or other materials of similar properties on the load box platform and possibly on walls and wall extensions. Non-compliance with the instructions provided could invalidate the guarantee. Loading of material in pieces or solid lumps must be from a low height. The load must not fall with great force on the floor of the load box, even if it is protected.

Hazardous loads

DANGER



If it is necessary to carry permitted hazardous materials, acquaint yourself with the regulations concerning transport of hazardous materials in force in the given country and also the regulations of the ADR agreement.

Carefully read the information leaflets provided by the load manufacturer, and to observe the instructions for transporting and handling the load. Ensure whether during loading work it is necessary to apply additional personal protection (masks, rubber gloves etc.)

According to the European ADR agreement concerning the international road transport of hazardous materials, the transport of this type of load (defined in detailed by this agreement) is forbidden with the use of agricultural trailers. The only exception are plant protection

materials and artificial fertilisers, which may be transported on agricultural trailers on the condition that they are transported in the appropriate packaging and in quantities envisaged by the ADR agreement.

High volume loads

High-volume loads (light with a high volume), such as hay, straw bales - rectangular or round, green fodder, etc., are recommended to be loaded with the aid of the appropriate mechanical devices: bale grabs, forks, etc. The load may be loaded even above the edge of the load box extension walls paying special attention to trailer stability and proper fixing and protection of load. Remember that higher loading has a negative effect on trailer stability.

Loads in packaging

Loads transported in packaging (boxes, sacks) must be laid closely side-by-side beginning from the front side of the trailer. If it is essential to lay several layers, particular groups should be stacked alternately (in block system). The load must be laid tightly together and on the whole surface of the trailer floor. Otherwise, the load will move during travel. Due to the trailer design (the load box designed for the transport of agricultural crops and products, lack of load securing points), materials in packaging may not be loaded above the top of the walls or extensions of load box. A higher load layer may move during travel and cause significant damage to the wall extensions and the load may spill.

DANGER



Overloading the trailer, erroneous loading and securing of the load is the most frequent cause of accidents during transport.

The load must be arranged in such a way that it does not threaten the stability of the trailer and does not hinder driving.

Ensure that during unloading / loading or raising the load box nobody is near the trailer. Before tipping load box ensure that there is visibility and make certain that there are no bystanders. The arrangement of the load may not cause an overload on the axle system or hitch system of the trailer.

Materials which may cause corrosion of steel, chemical damage or react in any other way negatively affecting the trailer structure may be transported only on condition of appropriate load preparation. Materials must be tightly packed (in plastic foil sacks, plastic containers

etc.). During transport, packaging contents may not come into contact with load box. Therefore, ensure the appropriate tightness of containers.

**DANGER**

If there is a danger of load packaging moving, do NOT transport this type of material. A moving load constitutes a serious hazard during travel for the tractor driver and other road users.

Final remarks

Due to diversity of materials, tools, methods of fixing and securing the load, it is impossible to describe all methods of loading. While working be guided by caution and own experience. The trailer user must carefully read the regulations concerning road transport and comply with them.

**DANGER**

The trailer is not intended to transport people, animals or hazardous materials (with the exception of loads specified in section 4.4).

The arrangement of the load may not cause an overload on the axle or hitch system of the trailer.

4.5 TRANSPORTING LOADS

When driving on public or private roads, respect the road traffic regulations, exercise caution and prudence. Listed below are the key guidelines for driving the tractor and trailer combination.

- Before moving off make sure that there are no bystanders, especially children, near the trailer or the tractor. Take care that the driver has sufficient visibility.
- Make sure that the trailer is correctly attached to the tractor and tractor's hitch is properly secured.
- Vertical load borne by the trailer drawbar eye affects the steering of the agricultural tractor.

- The trailer must not be overloaded, loads must be uniformly distributed so that the maximum permissible trailer axle and hitch loads are not exceeded. The trailer's maximum carrying capacity must not be exceeded as this can damage the trailer and pose a risk to the operator or other road users.
- Permissible design speed and maximum speed allowed by road traffic law must not be exceeded. The towing speed should be adapted to the current road conditions, load carried by the trailer, road surface conditions and other relevant conditions.
- Trailer may be towed on slopes of up to 5° and unloading must take place only on a level surface. Be especially careful when transporting bulky materials on slopes.
- When not connected to the tractor, the trailer must be immobilised using parking brake and possibly also with chocks or other objects without sharp edges placed under the front and back wheels. Do NOT leave unsecured trailer. In the event of machine malfunction, pull over on the hard shoulder avoiding any risk to other road users and position reflective warning triangle according to traffic regulations.
- When driving on public roads, the trailer must be marked with a slow-moving vehicle warning sign attached to the rear wall of load box, if the trailer is the last vehicle in the group.
- While driving on public roads the trailer must be fitted with a certified or authorised reflective warning triangle.
- When driving, comply with all road traffic regulations, indicate an intention to turn using indicator lamps, keep all road lights and indicator lights clean at all times and ensure they are in good condition. Any damaged or lost lamps or indicator lights must be immediately repaired or replaced.
- Avoid ruts, depressions, ditches or driving on roadside slopes. Driving across such obstacles could cause the trailer or the tractor to suddenly tilt. This is of special importance because loaded trailer's centre of gravity is higher (especially a high volume load), which reduces safety. Driving near ditches or channels is dangerous as there is a risk of the wheels sliding down the slope or the slope collapsing.

- Speed must be sufficiently reduced before making a turn or driving on an uneven road or a slope.
- When driving, avoid sharp turns especially on slopes.
- Please note that the braking distance of the tractor and trailer combination is substantially increased at higher speeds and loads.
- Monitor trailer's behaviour when travelling on an uneven terrain, and adjust driving speed to road conditions, slow down early enough when turning.
- The trailer is designed to operate on slopes up to 5°. Driving trailer across ground with steeper slopes may cause the trailer to tip over as a result of loss of stability. Prolonged driving across steep ground may lead to loss of braking efficiency.

ATTENTION

Prior to moving off with the trailer hitched, ensure that:



- *pins connecting the load box with the lower frame are properly inserted and secured against falling out,*
- *lug pins of wall extensions are secured against falling out using cotter pins.*

Travel with a high-volume load by ruts, ditches, roadside slopes etc. constitutes a great risk of overturning the trailer. Exercise particular caution.

4.6 UNLOADING

The trailer is equipped with hydraulic tipping system as well as the frame and the load box with proper structure allowing tipping sideways and to the rear. Tipping of the load box is controlled from driver's cab using external tractor hydraulic system manifold.

Unloading of the trailer is performed in the following sequence:

- ➔ tractor and trailer must be placed to drive forwards on flat and hard ground,
- ➔ immobilise tractor and trailer with parking brake,

- ➔ tipping pins (1) and (2) – figure (4.3), (connecting load box to lower frame) should be placed and properly interlocked on the side, which will be used to unload;
 - ⇒ Pins and individual sockets are designed so it is impossible to place them on the opposite diagonal side of the load box, which would damage the trailer,
- ➔ grip (3) of correctly locked pin is vertical (directed downward) – figure (4.3),

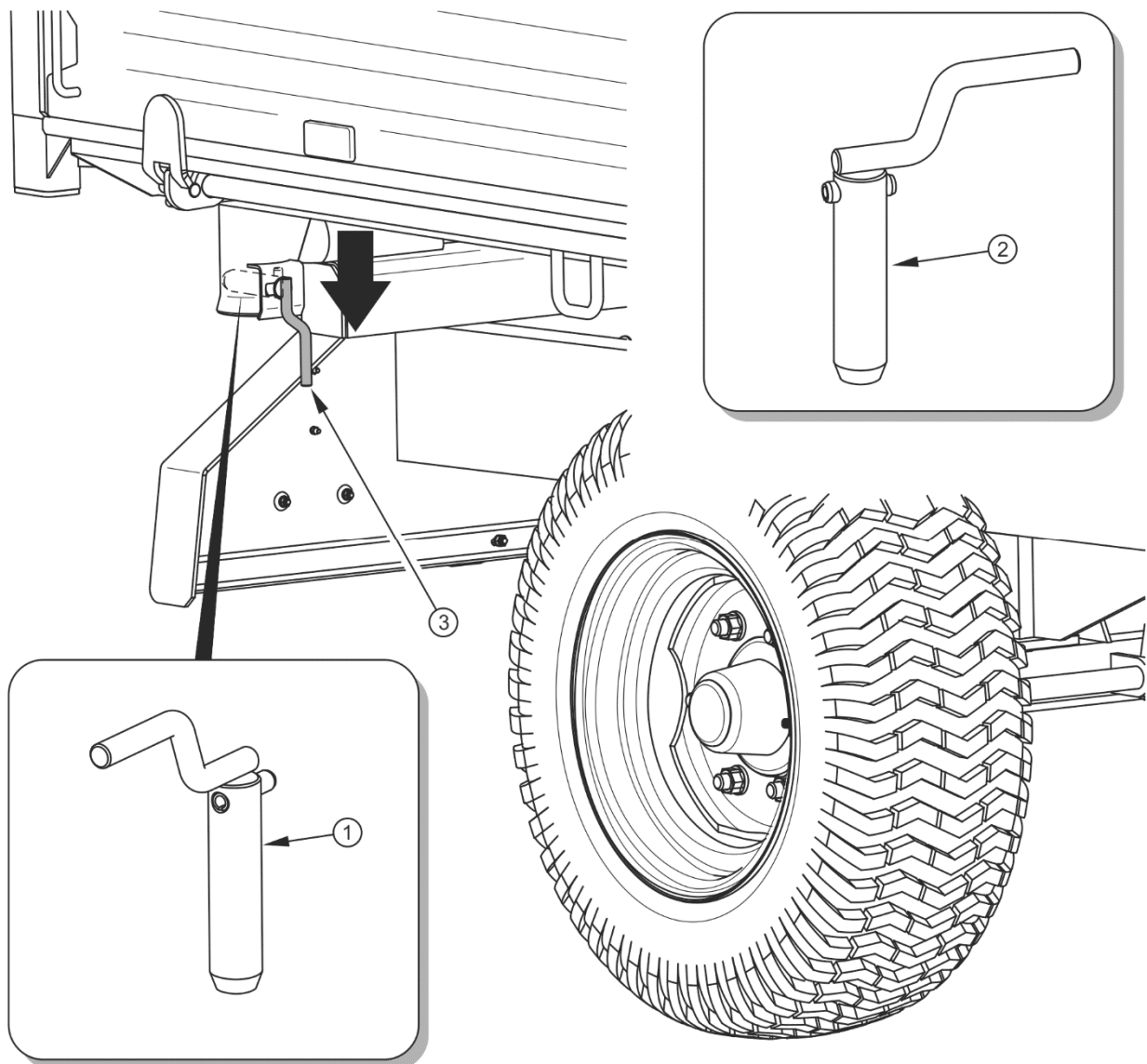

FIGURE 4.3 Bolting tipping pins

(1) tipping pin I, (2) tipping pin II, (3) tipping pin lug

- ➔ open appropriate locks of walls and/or wall extensions or open the chute sliding gate in the rear wall (depending on the direction in which unloading should take place);
 - ⇒ during opening exercise caution, because the load may exert great pressure on the walls,
- ➔ place the control lever of the hydraulic tipping system circuits in position 1 -- tipping of the first trailer,
- ➔ proper unlocking of closing locks.
- ➔ initiate tipping of the load box using the selective control valve lever in the operator's cabin,

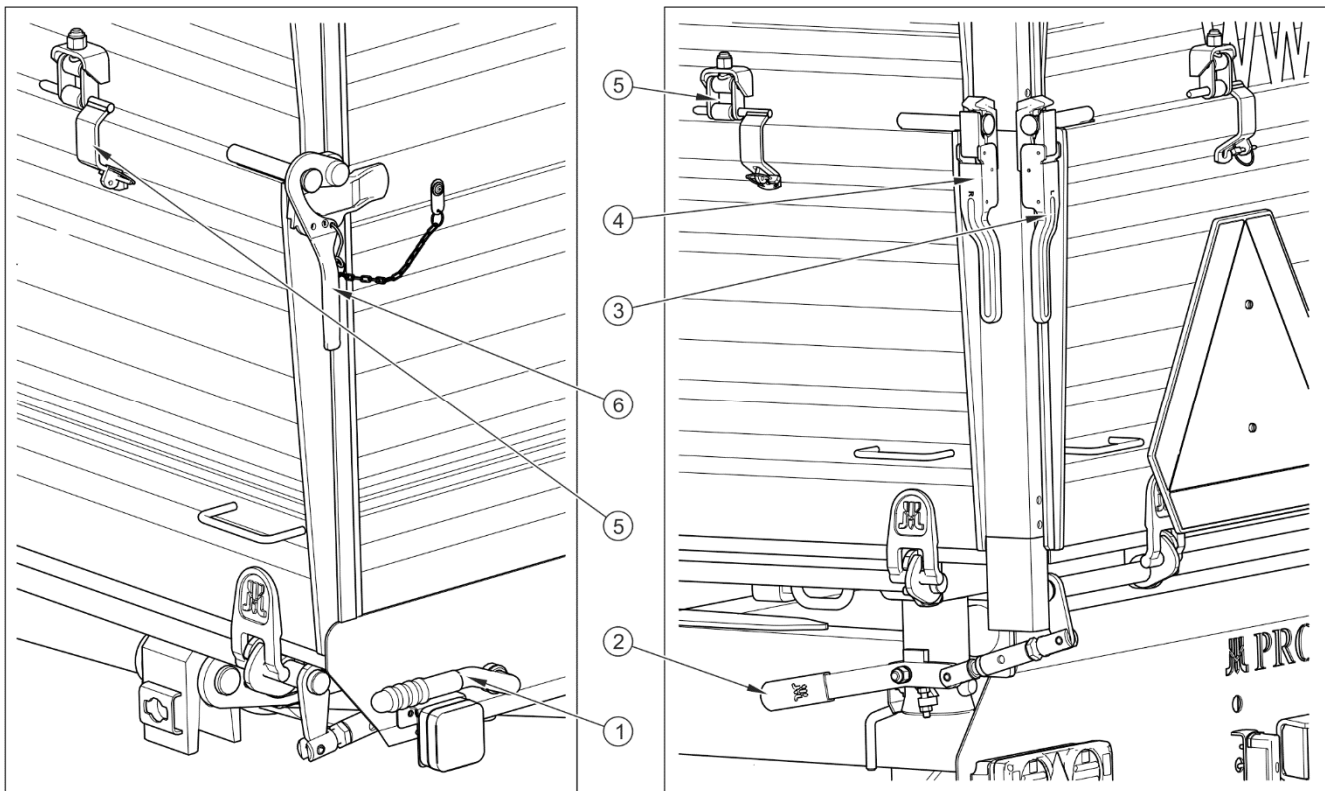

FIGURE 4.4 Locks of load box walls and wall extensions

(1) right wall locking lever, (2) rear wall locking lever, (3) rear wall lock (left), (4) side wall lock (rear left), (5) wall extension hinge, (6) side wall lock (front right)

- ➔ after unloading, lower load box, clean the residual material from the load box edges and walls,

- ➔ close and secure the walls and wall extensions or chute opening,
- ➔ before moving off make sure that tipping pins are in correct position, i.e. with the handle facing downward.

ATTENTION



It is not recommended to unload the load box by opening the walls downwards (when lower locks of the load box are locked). Load exerting pressure on the walls may hurt the operator or damage the trailer.

Incorrectly locked and secured pins may cause damage to trailer.

If a second trailer is hitched, it should be unloaded only when the load box of the first trailer has been lowered and the hydraulic tipping system control lever is placed in position 2 -- tipping of the second trailer.

TIP



It is recommended to use wheel chocks in order to additionally secure the trailer during unloading. When unloading high-volume materials, for example branches, the trailer's rear wall may be opened downwards. The help of a second person is recommended during unloading.

DANGER



Tipping the load box must be done on hard and level ground.

Use only original pins with a handle. Using third-party pins could damage the trailer. Tipping pins must be correctly inserted and locked.

When opening load box side wall locks take particular care, because of the pressure of the load on the wall.

When using the trailer with wall extensions, pay attention to the stability and risk of tipping the trailer over and control the trailer body movements on uneven ground.

Rear load box wall is equipped with chute slide gate (1) – figure (4.5) and chute opening (2) (optional equipment) which are used for unloading loose materials. Chute design allows very accurate dosing of the material to packaging (sacks, boxes etc.). The opening gap can be controlled using lever (3). In order to do that loosen the bolt interlocking slide gate (4), open

the slide as required and lock again using the bolt. When unloading through the chute do not open wall locks or wall extension locks and tipping of the load box must be done very slowly and without jerking. Raising the load box quickly will exert large pressure on the rear part of the load box due to displacement of the carried material and could compromise trailer's stability.

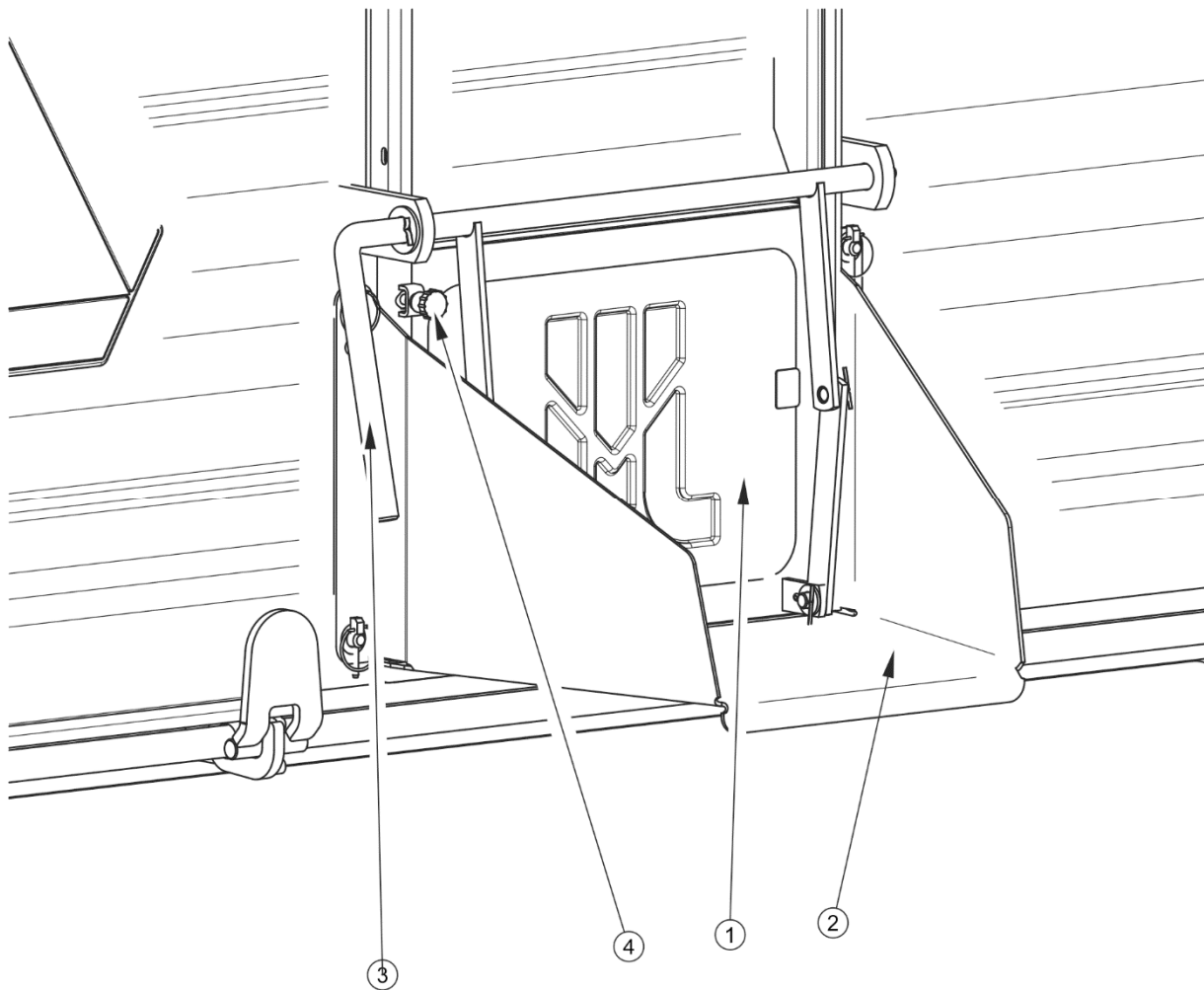

FIGURE 4.5 Chute

(1) chute slide gate, (2) chute, (3) lever, (4) locking bolt

While unloading bulky materials be especially careful. Do NOT tip load box on uneven or wet ground and move and jerk trailer during unloading. Bulky materials are normally difficult to unload. Therefore, proceed cautiously and patiently. Bulky materials are recommended to be unloaded by tipping the load box to the rear. Careless operation of trailer may pose a danger to operators and bystanders can also cause damage to the machine.

DANGER

When closing the rear chute gate or the walls take particular care to avoid crushing fingers.

Ensure that during unloading nobody is near tipped load box or load material pouring out.



Tipping may only be performed when trailer is hitched to tractor.

High-volume materials may be unloaded by tipping the load box to the rear only.

Do NOT jerk the trailer forwards if load is bulky or reluctant to pour and does not unload.

Do NOT tip load box in strong gusty winds conditions.

Do NOT move off or drive when load box is raised.

4.7 PROPER USE AND MAINTENANCE OF TYRES

- When working on the tyres, chocks or other objects without sharp edges should be placed under the wheels of the trailer to prevent it from rolling. Wheels can be taken off the trailer axle only when the trailer is not loaded.
- Repair work on the wheels or tyres should be carried out by persons trained and entitled to do so. This work should be carried out using appropriate tools.
- Inspect tightness of wheel nuts after the first use of the trailer, every 2 - 3 hours during first month of work and then every 30 hours of use (travel). The inspection should be repeated individually if a wheel has been removed from the wheel axle. Wheel nuts should be tightened according to recommendations provided in section 5 Maintenance.
- Regularly check and maintain correct air pressure in tyres according to Operator's Manual (especially if trailer is not used for a longer period).
- Air pressure in tyres should be also checked during the whole day of intensive work. Please note that higher temperatures could raise tyre pressure by as much as 1 bar. At high temperatures and pressure, reduce load or speed.
- Do not release air from warm tyres to adjust the pressure or the tyres will be underinflated when temperatures return to normal.

- Protect tyre valves using suitable caps to avoid soiling.
- Do not exceed the trailer's maximum design speed.
- When the trailer is operated all day, stop working for a minimum of one hour in the afternoon.
- Adhere to 30 minutes rest for cooling tyres after driving 75 km or after 150 minutes of continuous travel depending on which occurs first.
- Avoid potholes, sudden manoeuvres or high speeds when turning.

SECTION

5

MAINTENANCE

5.1 PRELIMINARY INFORMATION

When using the trailer, regular inspections of its technical condition are essential and the performance of maintenance procedures, which keep the machine in good technical condition. In connection with this the user of the trailer is obliged to perform all the maintenance and adjustment procedures defined by the Manufacturer.

Repairs during the guarantee period may only be performed by authorised service points.

Detailed procedures and extent of activities which the user may perform by himself are described in this section. In the event of unauthorised repairs, changes to factory settings and other actions, which are not regarded as possible for the trailer operator to perform, the user shall invalidate the guarantee.

5.2 SERVICING BRAKES AND AXLES

5.2.1 PRELIMINARY INFORMATION

Work connected with the repair, change or regeneration of axle and brakes elements should be entrusted to specialist establishments, having the appropriate technology and qualifications for this type of work.

The responsibilities of the user are limited to:

- initial inspection of axle brakes,
- inspection and adjustment of slackness of axle bearings,
- mounting and dismounting wheel, inspection of wheel tightening,
- checking air pressure, evaluating technical condition of wheels and tyres,
- mechanical brakes adjustment,
- change of parking brake cable and adjustment of cable tension.

Procedures connected with:

- changing grease in axle bearings,
- changing bearings, hub seals,
- changing brake linings, repairing brake,

may be performed by specialist workshops.



DANGER

Do NOT use the trailer when brake system is unreliable.

5.2.2 CHECKING WHEEL AXLE BEARINGS FOR SLACKNESS

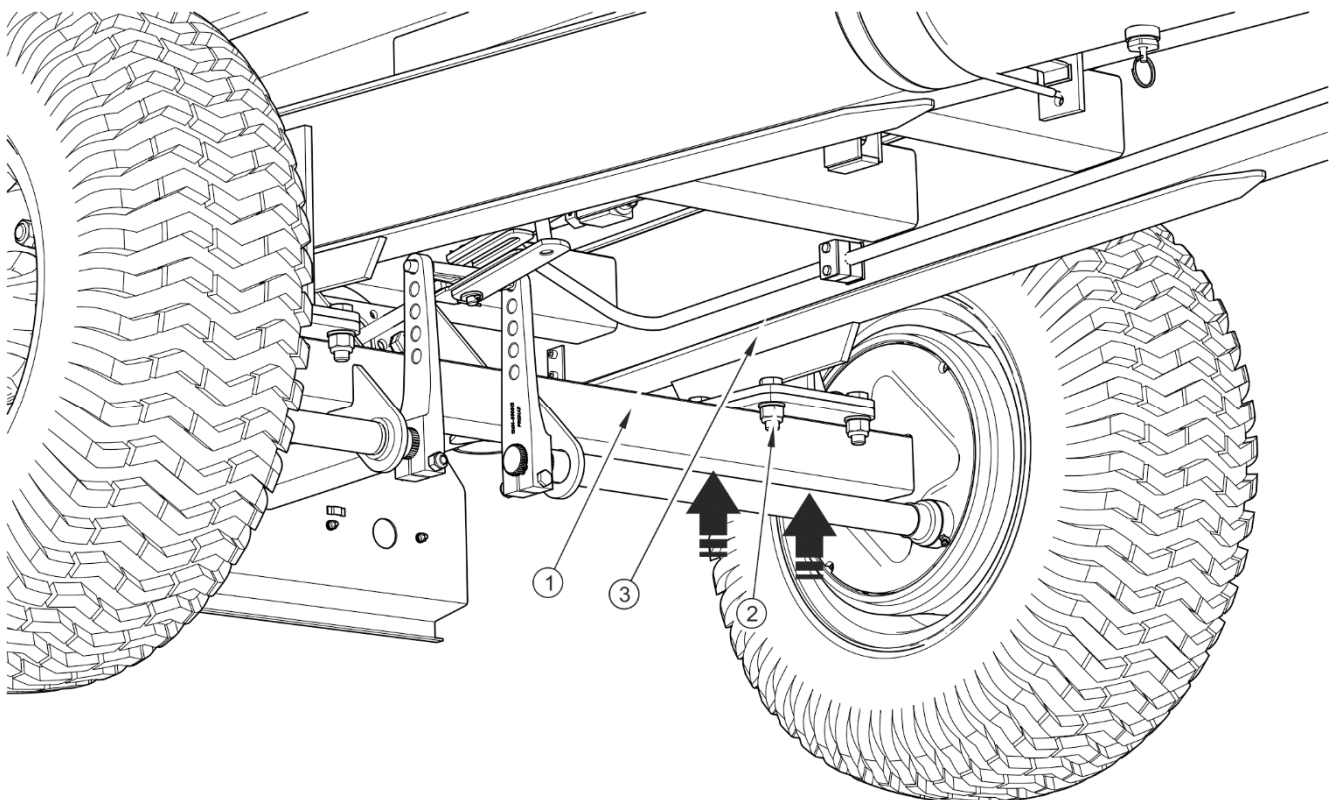

FIGURE 5.1 *Lifting jack support point*

(1) wheel axle, (2) bolt, (3) lower frame

Preparation procedures

- ➔ Hitch trailer to tractor, immobilize tractor with parking brake.
- ➔ Park tractor and trailer on hard level ground.
 - ⇒ Truck tractor must be placed to drive forward.
- ➔ Place chocks under the trailer's wheel that will not be raised. Ensure that trailer shall not move during inspection.

- ➔ Raise the wheel (opposite to the side where chocks are placed).
 - ⇒ The lifting jack should be placed between bolts (2) - figure (5.1) securing axle (1) to lower frame (3). Recommended support points are marked with arrows. Lifting jack must be suitable for the weight of trailer.

Checking wheel axle bearings for slackness

- ➔ Turning the wheel slowly in both directions check that movement is smooth and that the wheel rotates without excessive resistance.
- ➔ Turn the wheel so that it rotates very quickly, check that the bearing does not make any unusual sounds.
- ➔ Moving the wheel try to detect slackness.
 - ⇒ You may use a lever placed under the wheel supporting the other end of the lever on the floor.
- ➔ Repeat the inspection procedure for each wheel individually, remembering that the jack must be on the side opposite to the chocks.

If slackness is felt, adjust bearings. Unusual sounds coming from bearing may be symptoms of excessive wear, dirt or damage. In such an event, the bearing, together with sealing ring, should be replaced with new parts, or cleaned and greased again. During inspection of bearings, ensure that possibly detected slackness comes from the bearings and not from the mounting of the axle to trailer frame (3) by means of U bolts (2).



Check wheel axle bearings for slackness

- *after travelling the first 1,000 km,*
- *after intensive use of trailer,*
- *every six months use or every 25,000 km.*

Check condition of hub cover, if necessary replace with a new cover. Inspection of bearing slackness may only be conducted, when the trailer is hitched to a tractor, and the load box is empty.

**DANGER**

Before commencing work the user must read the instructions for lifting jack and adhere to the manufacturer's instructions.

The lifting jack must be stably supported on the ground and so must the axle.

Ensure that trailer shall not move during inspection of axle bearing slackness.

5.2.3 ADJUSTMENT OF SLACKNESS OF WHEEL AXLE BEARINGS

The wheel should turn smoothly without jamming or detectable resistance. Adjustment of bearing slackness may only be conducted when the trailer is not loaded and is hitched to the tractor.

Ensure that the trailer is properly secured and will not move during wheel dismounting.

Adjustment of slackness of wheel axle bearing

- ➔ Take off hub cover (1) – figure (5.2).
- ➔ Take out cotter pin (3) securing castellated nut (2).
- ➔ Tighten castellated nut in order to eliminate slackness.
 - ⇒ Wheel should rotate with insignificant resistance.
- ➔ Undo nut (not less than 1/3 rotation) to align the nearest thread groove with the opening in wheel axle pin. Wheel should rotate without excessive resistance.
 - ⇒ Nut must not be excessively tightened. Do not apply excessive pressure because working conditions of the bearings may deteriorate.
- ➔ Secure castellated nut with cotter pin and mount the hub cap.
- ➔ Delicately tap the hub cap with rubber or wooden mallet.

The wheel should turn smoothly without stiffness or detectable resistance not originating from abrasion of brake shoes in brake drum. Adjustment of bearing slackness may only be conducted when the trailer is hitched to tractor and the load box is empty.

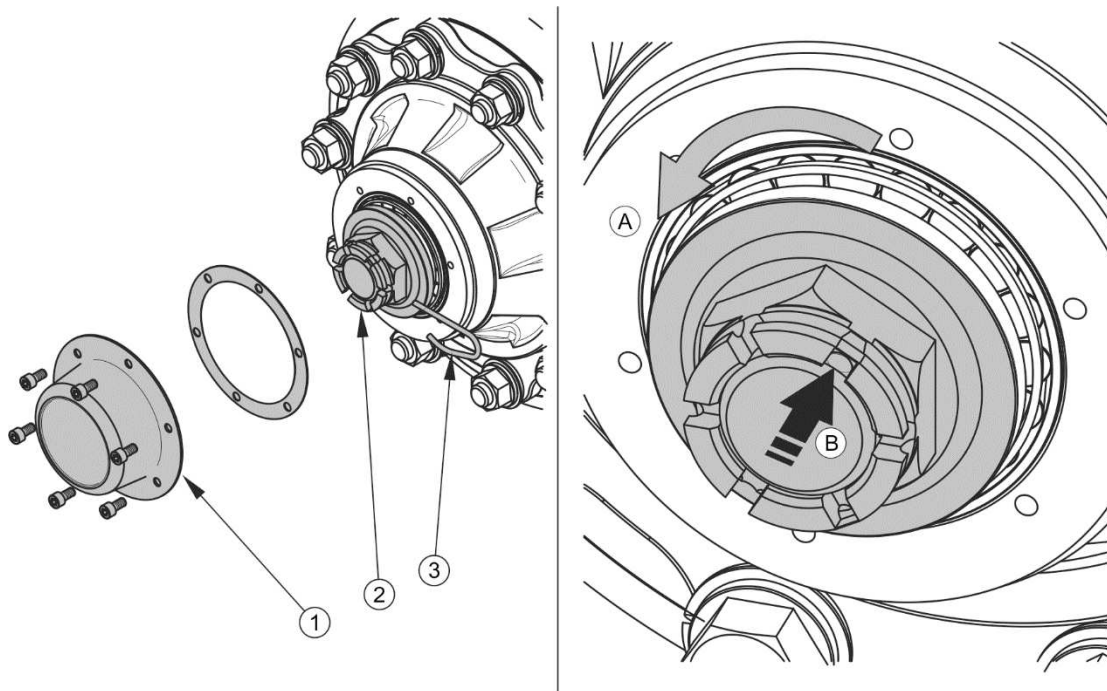

FIGURE 5.2 Adjustment of axle bearings

(1) hub cover, (2) castellated nut, (3) cotter pin



TIP

If the wheel is dismantled, bearing slackness is easy to check and adjust.

5.2.4 MOUNTING AND DISMOUNTING WHEEL, INSPECTION OF WHEEL NUT TIGHTENING

Dismounting wheel

- ➔ Immobilise trailer with parking brake.
- ➔ Place chocks under the wheel that will not be dismantled.
- ➔ Ensure that trailer shall not move during wheel dismantling.
- ➔ Loosen wheel nuts according to sequence shown in figure (5.3).
- ➔ Place a lifting jack and raise the trailer to a sufficient height so that the wheel to be replaced does not touch the ground.

- ⇒ The lifting jack should have sufficient lifting capacity and should be technically reliable.
 - ⇒ The lifting jack must be positioned on a level and hard surface so as to prevent sinking into the ground or relocating the jack during lifting.
 - ⇒ If necessary, use proper backing plates in order to prevent the lifting jack from sinking into the ground.
- ➔ Dismount wheel.

Wheel mounting

- ➔ Clean axle pins and nuts of contamination.
 - ⇒ Do not grease thread of nuts and pins.
- ➔ Check condition of pins and nuts, if necessary replace them.
- ➔ Place wheel on hub, tighten nuts so that wheel rim tightly fits the hub.
- ➔ Lower the trailer, tighten nuts according to recommended torque and given sequence.

Tightening nuts

Nuts should be tightened gradually diagonally, (in several stages, until obtaining the required tightening torque) using a torque spanner. If a torque spanner is not available, one may use an ordinary spanner. The arm of the spanner (L), figure (5.3), should be selected according to the weight of the person (F) tightening the nut. Remember that this method of tightening is not as accurate as the use of a torque spanner.



TIP

Wheel nuts should be tightened using the torque of 270 Nm - M18x1.5 nuts.

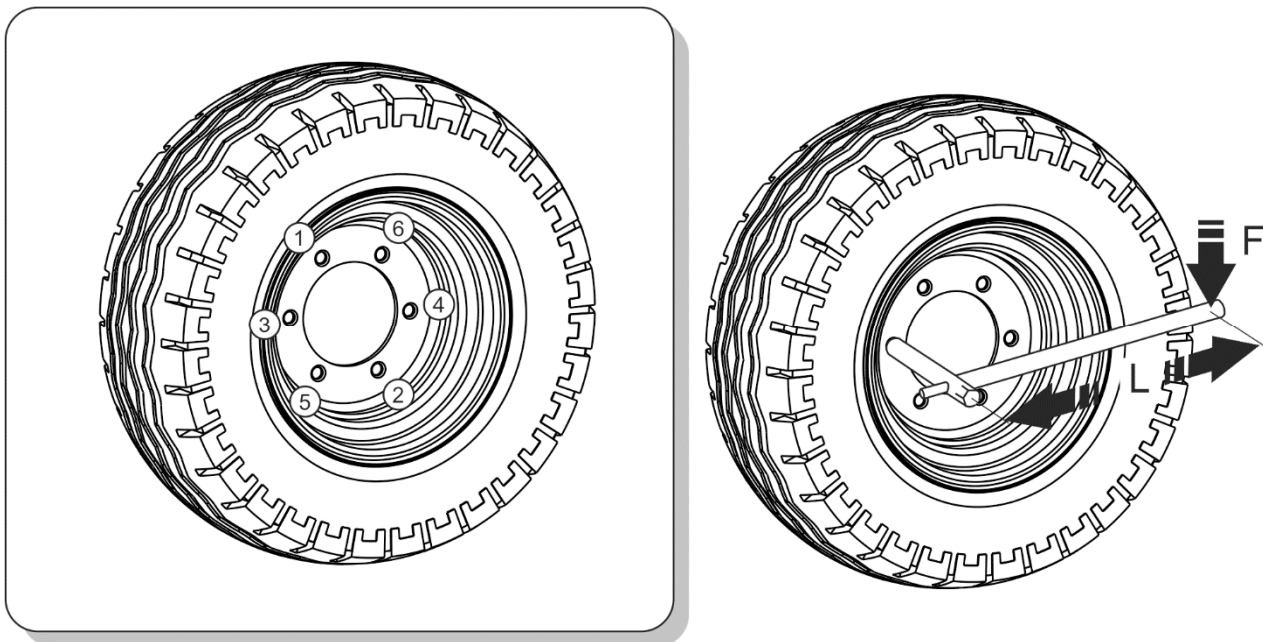

FIGURE 5.3 Sequence of nut tightening

(1) - (6) sequence of nut tightening, (L) spanner length, (F) user weight

TIP



- After the first use of trailer (one-time inspection).
- Every 2 – 3 hours of trailer travel (during the first month of trailer use).
- Every 30 hours of trailer travel.

The above actions should be repeated individually if a wheel has been removed from the wheel axle.

ATTENTION



Wheel nuts may not be tightened with impact wrench because of danger of exceeding permissible tightening torque, the consequence of which may be breaking the thread connection or breaking off the hub pin.

The greatest precision is achieved using a torque spanner. Before commencing work, ensure that correct tightening torque value is set.

TABLE 5.1 *Spanner arm*

WHEEL TIGHTENING TORQUE	BODY WEIGHT (F)	ARM LENGTH (L)
[NM]	[KG]	[M]
450	60	0.75
	70	0.65
	80	0.55
	90	0.50

5.2.5 CHECKING AIR PRESSURE IN TYRES, EVALUATING TECHNICAL CONDITION OF TYRES AND STEEL WHEELS

Air pressure in tyres should be checked each time after changing a spare wheel and at least once a month. In the event of intensive use, air pressure in tyres should be checked more frequently. During this time, the trailer must be unloaded. Checking should be done before travelling when tyres are not heated, or after an extended period of parking.



TIP

Tyre pressure values are specified in information decal, placed on wheel or on upper frame above trailer wheel.



DANGER

Damaged tyres or wheels may be the cause of a serious accident.

While checking pressure pay attention to technical condition of wheels and tyres. Look carefully at tyre sides and check the condition of tread.

In case of mechanical damage consult the nearest tyre service and check whether the tyre defect requires tyre replacement.

Wheels should be inspected with regard to distortion, breaking of material, breaking of welds, corrosion, especially in the area of welds and contact with tyre.

Proper technical condition and appropriate maintenance of wheels significantly extends the life of these components and ensures appropriate level of safety to trailer users.



Checking air pressure in tyres and visual inspection of steel wheels:

- every 1 month of use,
- if needed.

5.2.6 CHECKING THICKNESS OF BRAKE SHOE LININGS

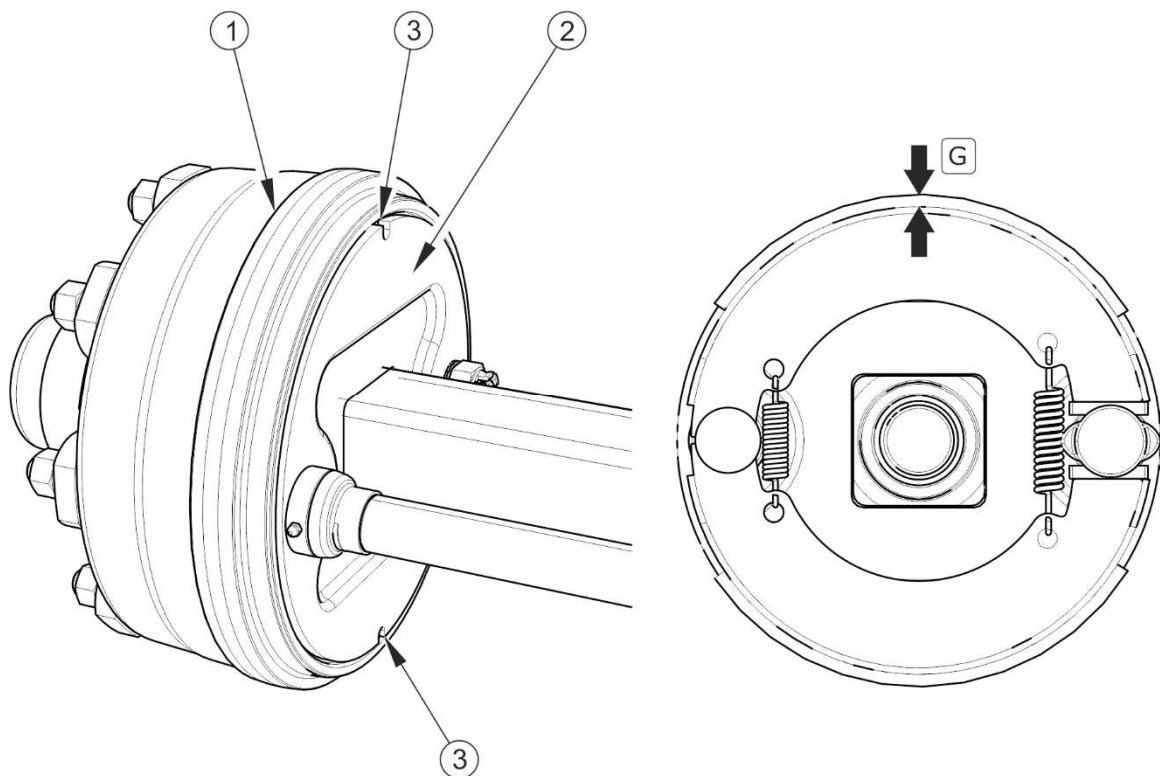

FIGURE 5.4 *Checking brake shoe linings*

(1) brake drum, (2) disc, (3) inspection openings, (G) thickness of brake shoe lining

During use of trailer, friction lining of brake drums is subject to wear. In such a case, the complete brake shoes should be replaced with new ones. Excessive wear of brake shoes is the condition in which the thickness of linings which are glued or riveted to steel structures of brake shoes is smaller than the minimum value. This condition is indicated by extended cylinder piston stroke. Check technical condition of brake shoe linings through inspection openings (3) – figure (5.4).



Thickness of brake shoe linings should be checked every 6 months.

**TIP**

Minimum thickness of brake shoe linings is 5mm.

5.2.7 ADJUSTMENT OF MECHANICAL BRAKES

Considerable wear of brake shoe linings results in increased brake cylinder rod stroke and worse braking efficiency.

During braking, the brake cylinder piston rod stroke should be within the specified operating range and the angle between brake cylinder piston rod (1) and expander arm (3) should be about 90°. Braking force decreases also when the operating angle of the brake cylinder piston rod (5), in relation to the expander arm (1), is wrong – figure (5.5). In order to obtain the optimum mechanical operating angle, the cylinder fork (6) must be installed on the expander arm (1) in such a manner as to ensure that the operating angle at full braking is about 90°.

**ATTENTION**

Incorrectly adjusted brake may cause rubbing of brake shoes against brake drums, which may lead to faster wear of brake linings and/or brake overheating.

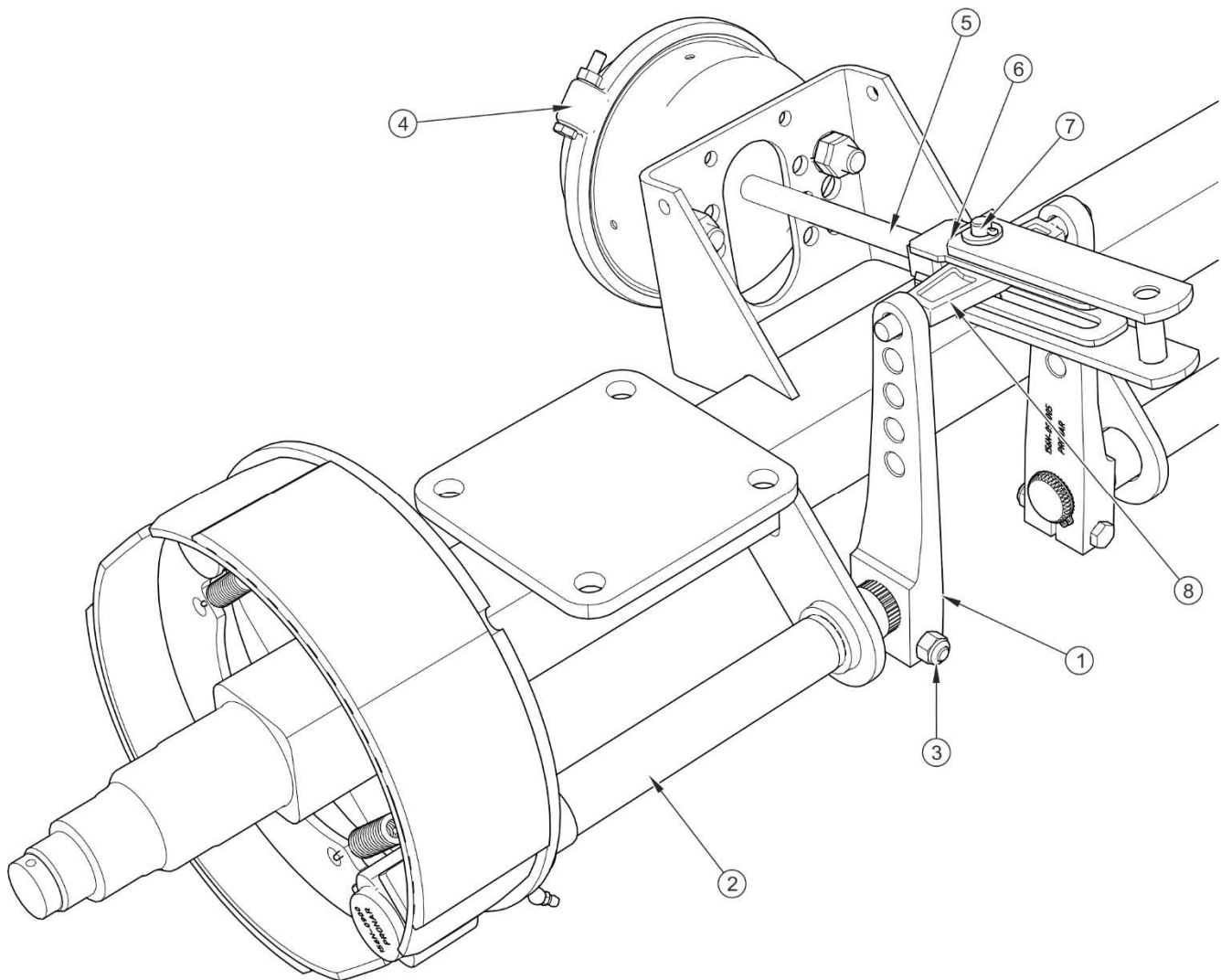

FIGURE 5.5 *Design of wheel axle brake*

(1) expander arm , (2) expander shaft, (3) securing bolt, (4) brake cylinder, (5) cylinder piston rod, (6) cylinder fork, (7) fork pin, (8) equalising bar

Adjustment must be made when:

- piston rod stroke amounts to 2/3 of maximum stroke,
- expansion levers are not set in parallel to each other during braking,
- repairs are made to braking system.

Trailer wheels must brake simultaneously. Brakes adjustment involves changing the position of the expander arm (1), Figure (5.6), in relation to expander shaft (2).

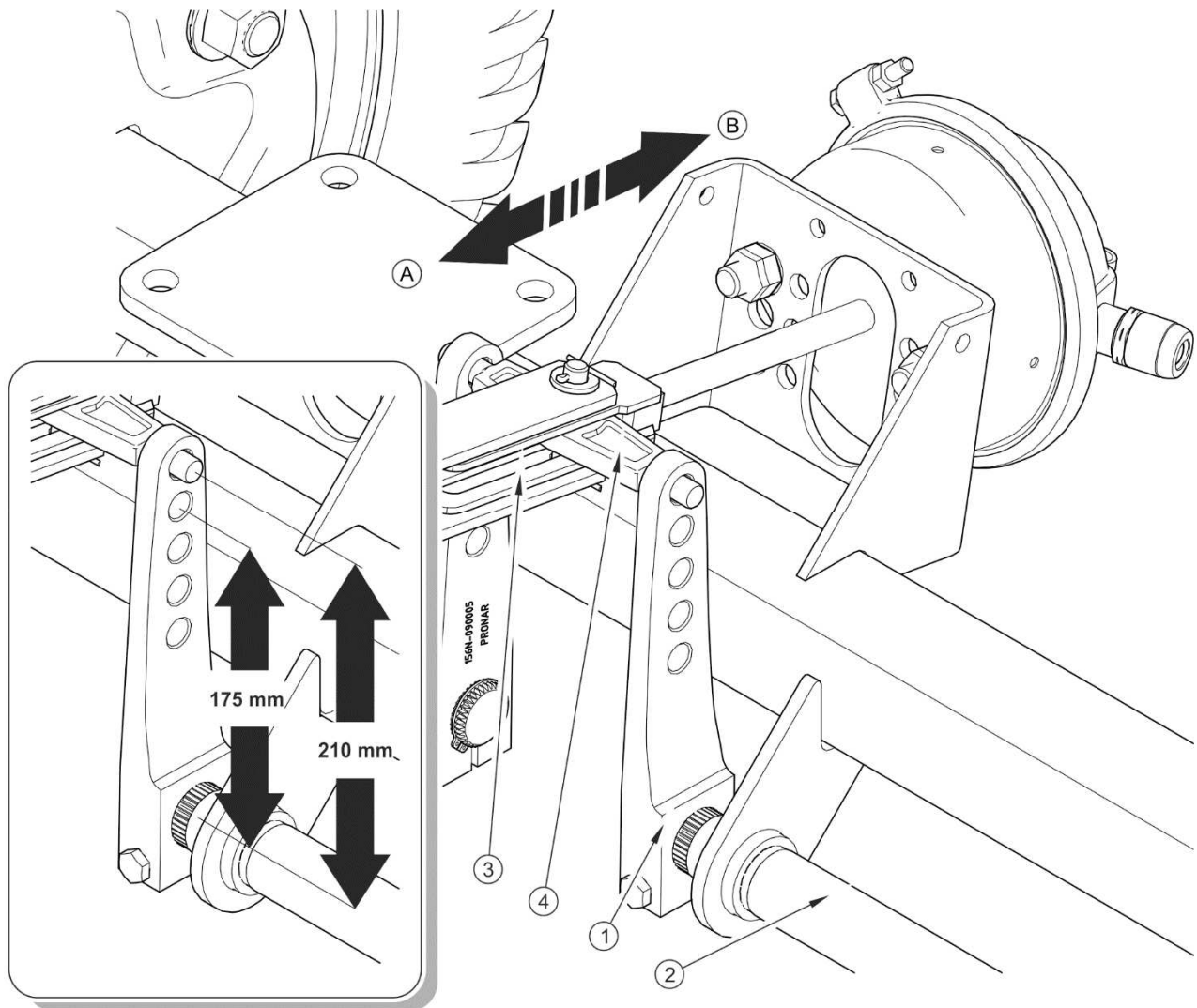

FIGURE 5.6 *Principle of brake adjustment*

(1) expander arm, (2) expander shaft, (3) equalising bar, (4) cylinder fork

Required maintenance activities

- ➔ Dismantle pin fixing the cylinder fork (4) with rudder bar (3).
- ➔ Mark position of expander arm (1) with regard to the shaft (2).
- ➔ Dismantle arm and set it in the appropriate position.
 - ⇒ in direction (A), if braking is too early,
 - ⇒ in direction (B), if breaking is too late.
- ➔ Repeat the process for the second arm.
- ➔ Replace pin fixing the cylinder fork to equalising bar.

Expander arm (1) should be moved by one notch in chosen direction. If the extent of cylinder action is still incorrect, move the lever again. After proper brake adjustment, at full braking, the expander arms should create the angle of 90° with the cylinder piston rod, and the stroke should amount to approximately half the length of the total stroke of the piston rod. After brake release expander arms may not be supported on any structural elements, because too little withdrawal of a piston ram may cause abrasion of brake shoes in drum and result in overheating trailer brakes. Expander arms must be positioned in parallel with regard to each other at full braking. If this is not so, adjust the position of the lever, which has the longer stroke.

If it is necessary to dismantle the equalising bar, remember or mark its original position in the expander arms. The mounting position is selected by the Manufacturer and may not be changed.



- *Before the period of intensive use.*
- *Every 6 months.*
- *After repair of braking system.*
- *In case of uneven trailer wheel braking.*

ATTENTION



The positions for fixing the brake cylinder in the bracket openings and the equalising bar in the expander arms are determined by the Manufacturer and must not be changed.

Each time when dismantling the pin or brake cylinder, the original fixing position should be marked.

TIP



Equalising bar position depends on the trailer version. In the trailer with the maximum design speed of 25km/h (standard version), the distance between the equalising bar and the expander shaft axis is 175mm. In the optional version of the trailer with the maximum design speed of 40km/h, the above-mentioned distance is 210mm (figure (5.6)).

5.2.8 REPLACEMENT OF OVERRUN BRAKE CABLE AND ADJUSTMENT OF CABLE TENSION.

If trailer braking is considerably delayed in relation to tractor braking, check brake cable tension and check if position of expander arms is correctly adjusted - see section 5.2.8.

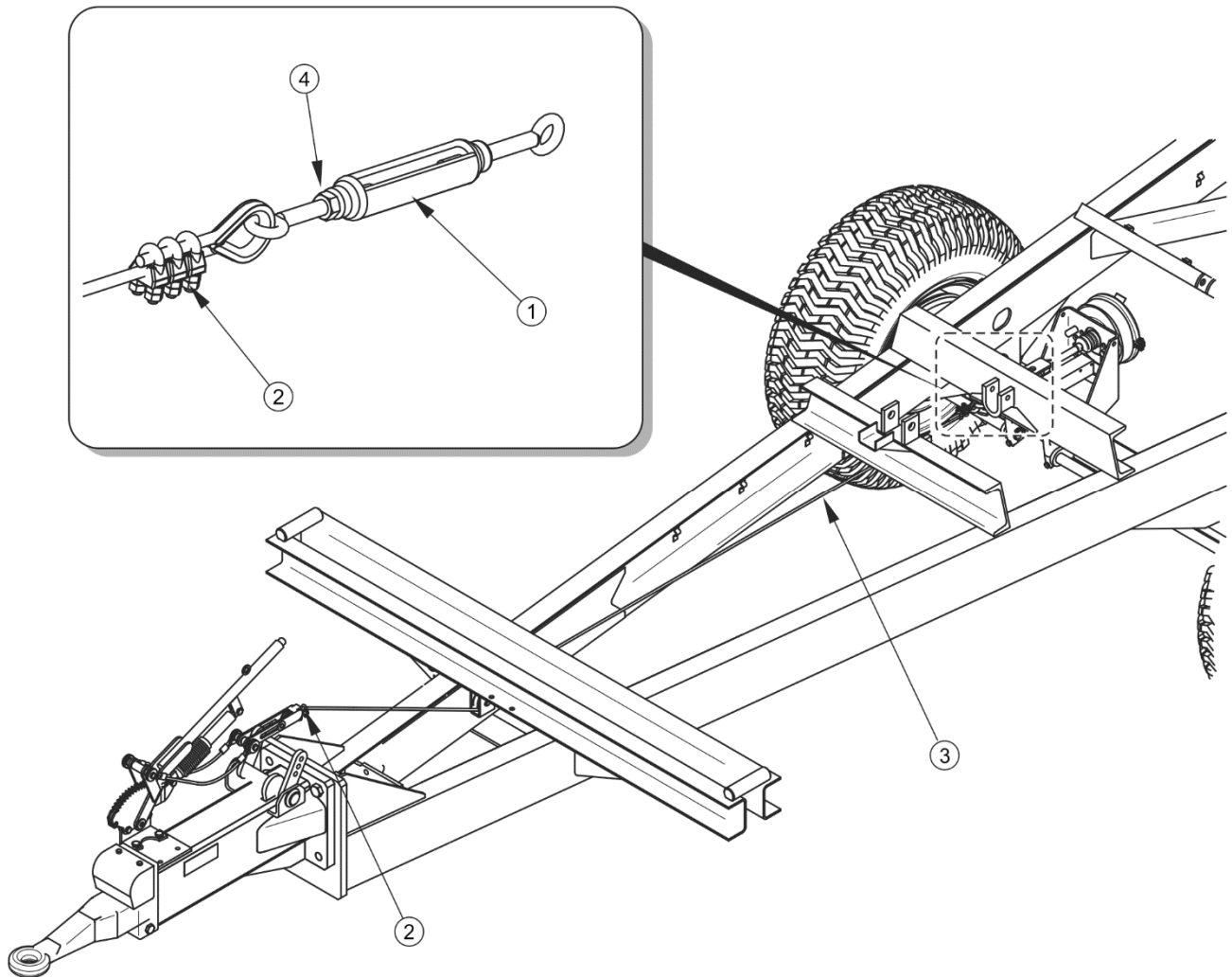

FIGURE 5.7 *Adjustment of overrun brake cable tension*

(1) tensioner, (2) U-bolt clamp, (3) steel cable, (4) counter nut

Required maintenance activities

- ➔ Check and adjust position of expander arms if necessary.
- ➔ Check efficiency and delay in action of overrun brake.
- ➔ If trailer braking is still considerably delayed, loosen counter nut (4) of tensioner (1) – figure (5.7).

- ➔ Tighten overrun brake cable (3) using tensioner (1).
 - ⇒ Excessive brake cable tension can cause more rapid wear of brake linings and, in extreme cases, very sudden braking and trailer wheel blocking.
- ➔ Tighten nut (4), check brake action.
 - ⇒ If problem continues repeat all actions.



Checking and adjustment of overrun brake:

- *every 12 months,*
- *if needed.*

Replacing the brake cable

- ➔ Loosen tensioner (1) as much as possible – figure (5.7).
- ➔ Unscrew the nuts of U-bolt clamps (2).
- ➔ Dismantle brake cable.
- ➔ Mount thimble and U-bolt clamps.
- ➔ Attach the end of cable to overrun drawbar pin.
- ➔ Connect the other end of cable to tensioner (1), mount U-bolt clamps.
- ➔ Adjust length and tension of brake cable.

5.2.9 REPLACEMENT OF PARKING BRAKE CABLE AND ADJUSTMENT OF CABLE TENSION.

Proper operation of the parking brake is dependent on the effectiveness of the rear axle brake and the correct brake cable tension.

Before the adjustment, make certain that the axle brake is correctly adjusted and is functioning properly.

Adjustment of parking brake cable tension should be conducted in the event of:

- stretching of cable,
- loosening of parking brake cable clamps

- after adjustment of axle brakes,
- after repairs of axle brake system,
- after repairs of parking brake system.

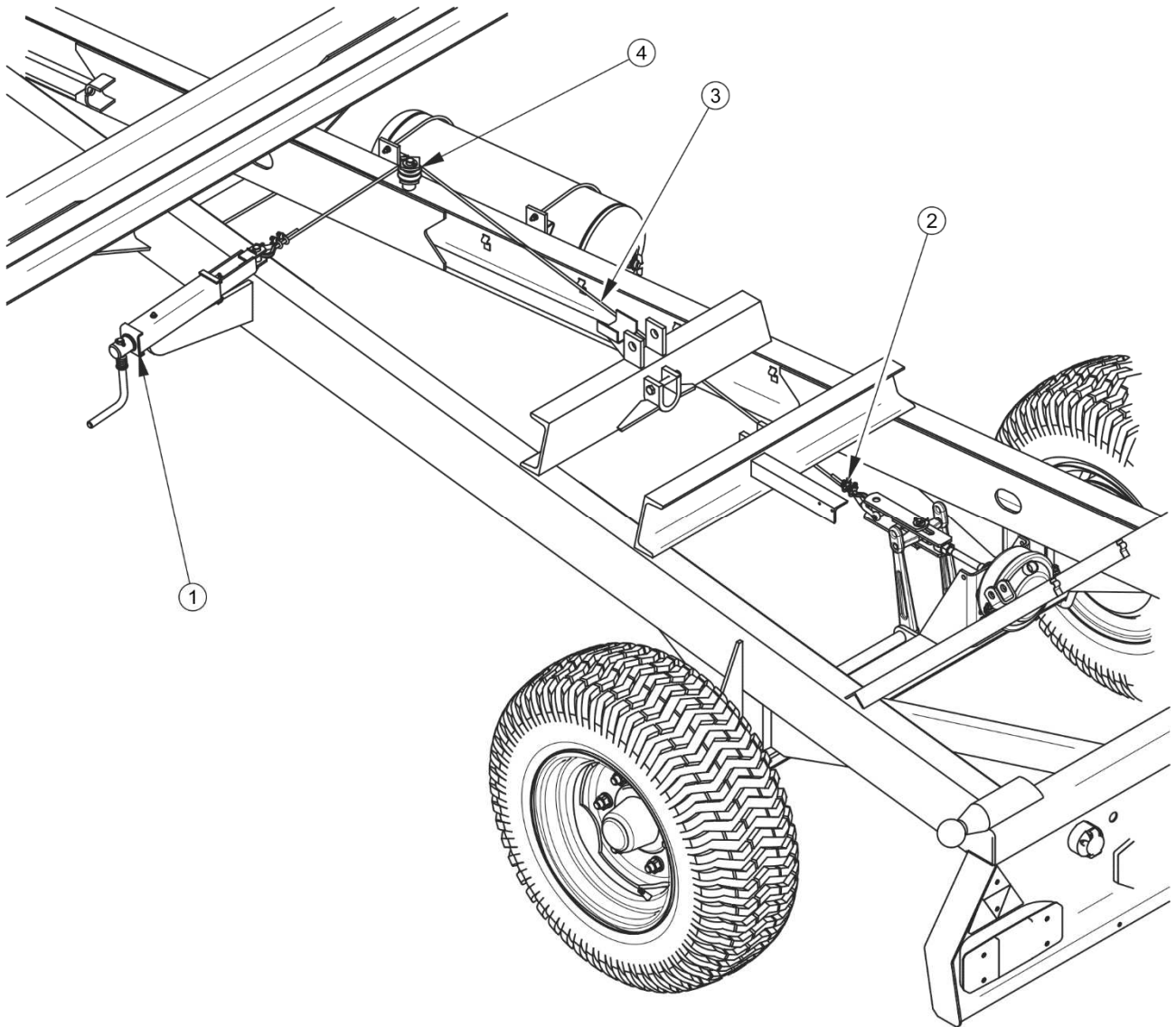

FIGURE 5.8 *Adjustment of main brakes*

(1) brake crank mechanism, (2) cable clamp nuts (3) hand brake cable, (4) guide roller

Replacing the parking brake cable

- ➔ Hitch trailer to tractor. Park trailer and tractor on level surface.
- ➔ Place wheel chocks under trailer wheel.
- ➔ Fully unscrew the bolt of the brake crank mechanism (1).

- ➔ Loosen nuts of U-bolt clamps located at the ends of cable.
- ➔ Dismantle proper shackles at the ends of the cable.
- ➔ Dismantle parking brake cable.
- ➔ Clean parking brake components, lubricate crank mechanism and pins of cable guide rollers.
- ➔ Install new cable.
 - ⇒ Parking brake cable must be fitted carefully.
 - ⇒ Thimbles and three clamps must be fitted at the ends of the cable.
 - ⇒ Clamps must be tightened. The distances between the clamps may not be less than 20 mm.
 - ⇒ Clamp jaws must be placed on the side of the load bearing cable - see figure (5.9).
 - ⇒ The first clamp should be placed directly on the thimble.
- ➔ After the first loading of cable, re-check the condition of cable ends, correct if necessary.

Adjustment of parking brake cable tension:

- ➔ Hitch trailer to tractor. Park trailer and tractor on level surface.
- ➔ Place chocks under trailer rear wheel.

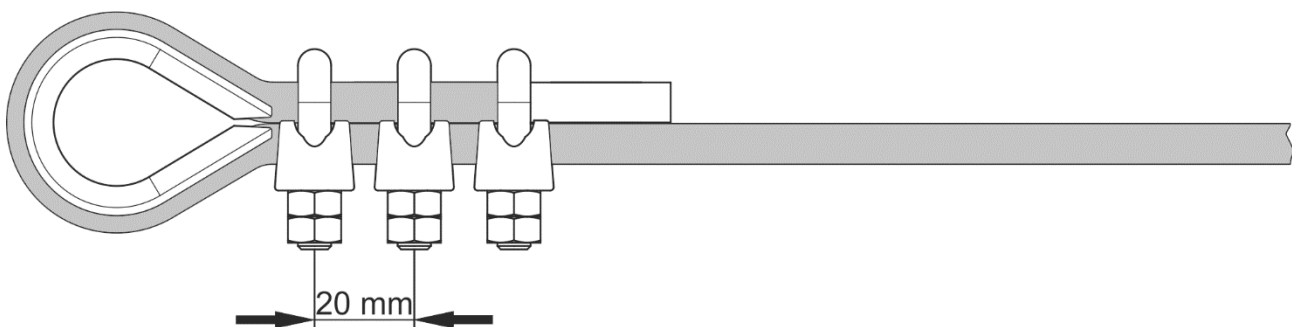

FIGURE 5.9 *Installing brake cable clamps*

- ➔ Unscrew the brake mechanism bolt maximally (1) – figure (5.8), (counterclockwise).

- ➔ Loosen nuts of U-bolt clamps on handbrake cable.
- ➔ Tighten cable and tighten clamps.
 - ⇒ Length of parking brake cable should be so selected that at total release of working and parking brake the cable would be loose and hanging by 1 - 2 cm.

Before the adjustment, make certain that the axle brake is correctly adjusted and is functioning properly.

Parking brake adjustment (in trailer version with overrun brake) is unnecessary if the main brake (overrun brake) operates properly.



Checking and/or adjustment of parking brake:

- *every 12 months.*
- *If needed.*

5.3 PNEUMATIC SYSTEM MAINTENANCE

5.3.1 PRELIMINARY INFORMATION

Work connected with the repair, change or regeneration of system components (brake cylinder, conduits, control valve, braking force regulator etc.) should be entrusted to specialist establishments, having the appropriate technology and qualifications for this type of work.



DANGER

Do NOT use the trailer when brake system is unreliable.

The duties of the operator connected with the pneumatic system maintenance include:

- checking tightness and visual inspection of the system,
- cleaning the air filter (filters),
- draining water from air tank,
- cleaning drain valve,

- cleaning and maintaining pneumatic conduit connections,

5.3.2 CHECKING AIR TIGHTNESS AND VISUAL INSPECTION OF PNEUMATIC SYSTEM

Checking air tightness of pneumatic systems

- ➔ Hitch trailer to tractor.
- ➔ Immobilise tractor and trailer with parking brake. Place chocks under trailer wheel.
- ➔ Start tractor in order to supplement air in trailer brake system tank.
 - ⇒ In single conduit systems air pressure should amount to approx. 5.8 bar.
 - ⇒ In double conduit systems air pressure should amount to approx. 8 bar.
- ➔ Turn off tractor engine.
- ➔ Check system components by releasing brake pedal in tractor.
 - ⇒ Pay particular attention to the connection of conduit and brake cylinder.
- ➔ Repeat the system check with depressed tractor brake pedal.
 - ⇒ The help of a second person is required.



Check system tightness

- *after travelling the first 1,000 km,*
- *each time after making repairs or changing system components,*
- *annually.*

In the event of the appearance of leaks, compressed air will escape at the places of damage, with a characteristic hiss. Lack of system tightness may be also detected by covering checked elements with washing fluid or other foaming preparations, which will not react aggressively with system components. It is recommended to use preparations commercially available designed to facilitate detecting air leaks. Damaged components should be replaced

or repaired. If leaks appear at connections then tighten the connections. If air continues to escape, replace connection components or seals with new ones.

Visual inspection of the system

During tightness inspection attention should additionally be given to technical condition and degree of cleanness of the system components. Contact of pneumatic conduit seals etc. with oil, grease, petrol etc. may cause damage and accelerate the ageing process. Bent, permanently deformed, cut or worn conduits should be replaced.



Visual inspection of the system

- *Conduct inspection of system at the same time as when checking tightness.*



ATTENTION

Repair, exchange or regeneration of pneumatic system components may only be performed in a specialised workshop.

5.3.3 CLEANING THE AIR FILTERS

Depending on trailer working conditions, but not less than once in three months, take out and clean air filter elements, which are located in pneumatic system connection conduits. Filter elements are used many times and are not subject to change unless they are mechanically damaged.



Cleaning the air filter (filters):

- *every 3 months of use,*

Required maintenance activities

- ➔ Reduce pressure in supply conduit.
 - ⇒ Pressure in conduit can be reduced by pressing the head of the pneumatic connection until resistance is felt.
- ➔ Slide out securing slide lock (1) – figure (5.10).

- ⇒ Hold the filter cover (2) with the other hand. After removing slide lock, the cover is pushed off by the spring located in the filter housing.

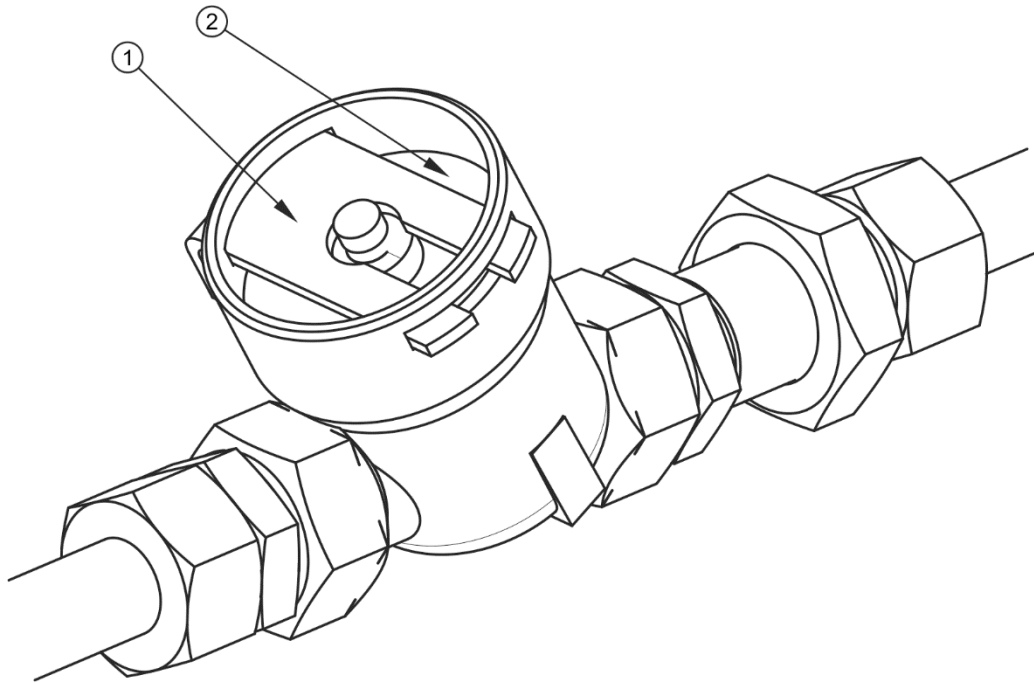

FIGURE 5.10 Air filter

(1) securing slide lock, (2) air filter cover

- ➔ The filter element and the filter body should be carefully cleaned and blown through with compressed air. Assembly should be done in reverse order.



DANGER

Before proceeding to dismantle filter, reduce pressure in supply conduit. While dismantling the slide lock, hold the cover with the other hand. Stand away from filter cover vertical direction.

5.3.4 DRAINING WATER FROM AIR TANK

Required maintenance activities

- ➔ Open out drain valve (1) placed in lower part of tank (2) – the tank is placed on brackets of right longitudinal frame of lower frame.

⇒ The compressed air in the tank causes the removal of water to the exterior.

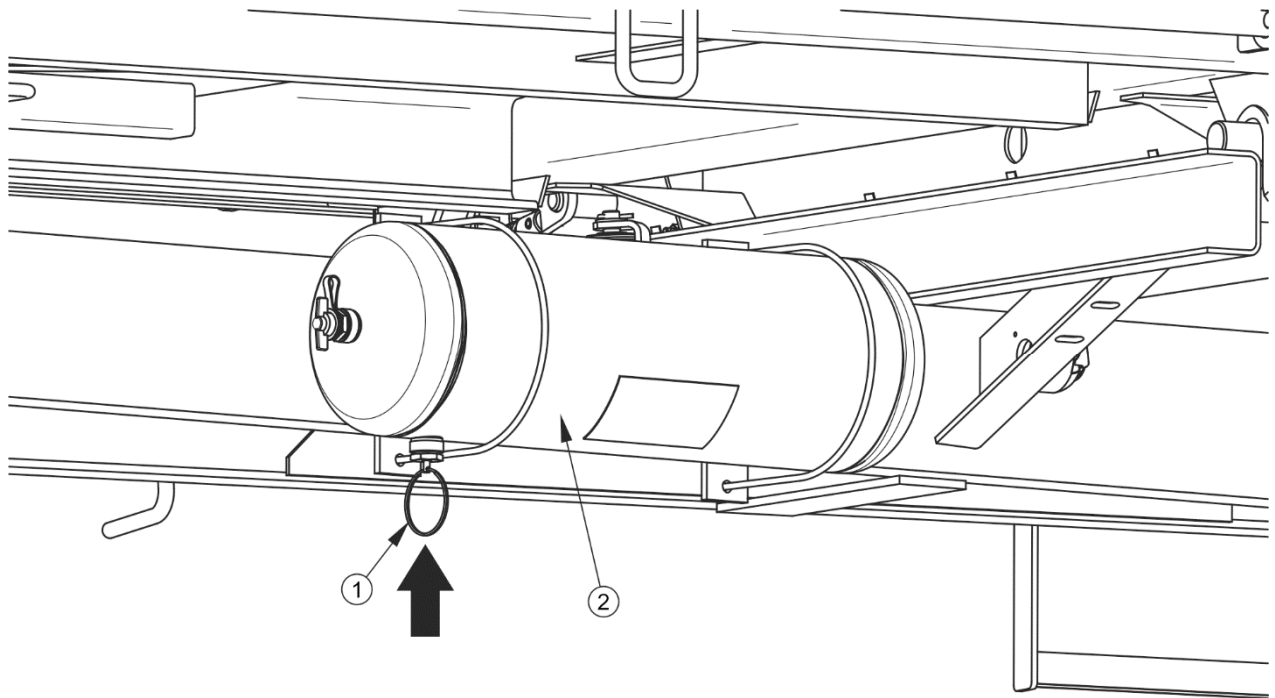

FIGURE 5.11 *Draining water from air tank*

(1) *drain valve*, (2) *air tank*

- ➔ Released valve stem should automatically close and stop flow of air from the tank.
 - ⇒ If the valve stem resists returning to its position, then the whole drain valve must be unscrewed and cleaned or replaced (if it is damaged) - see section 5.3.5.



Draining water from air tank:

- *every seven days of use.*

5.3.5 CLEANING THE DRAIN VALVE



DANGER

Release air from the air tank before dismantling drain valve.

Required maintenance activities

- ➔ Completely reduce pressure in air tank.
 - ⇒ Reduction of pressure in tank is achieved by tilting the drain valve stem.
- ➔ Unscrew valve.
- ➔ Clean the valve, blow it with compressed air.
- ➔ Change copper seal.
- ➔ Screw in valve, fill tank with air and check tank tightness.



Cleaning valve:

- *every 12 months (before winter period).*

5.3.6 CLEANING AND MAINTAINING PNEUMATIC CONDUIT CONNECTIONS AND PNEUMATIC SOCKETS



DANGER

Unreliable and dirty trailer connections may cause unreliability and faulty functioning of braking system.

Connection with damaged body should be replaced. In the event of damage to cover or seal, change these elements for new reliable elements. Contact of pneumatic connection seals with oils, grease, petrol etc. may cause damage and accelerate ageing process.

If the trailer is unhitched from the tractor, connections should be protected by covers and placed in their designated sockets. Before the winter period it is recommended to preserve the seal with special preparations (e.g. silicon grease for rubber elements).

Each time before hitching the machine, inspect technical condition and cleanness of connectors and sockets in tractor. If necessary, clean or repair tractor sockets.



Inspecting the trailer connections:

- *each time before hitching trailer to agricultural tractor.*

5.3.7 REPLACEMENT OF PNEUMATIC CONDUIT

Pneumatic conduits should be replaced when permanently deformed, cut or frayed.

Push-in fittings are used for connecting conduits with pneumatic system components. The fittings enable simple, fast and tight connection by pushing the conduits in. If leaks appear at connections, the user may tighten the fitting by himself using a tightening torque according to table (5.2). If air continues to escape, replace fittings with new ones.

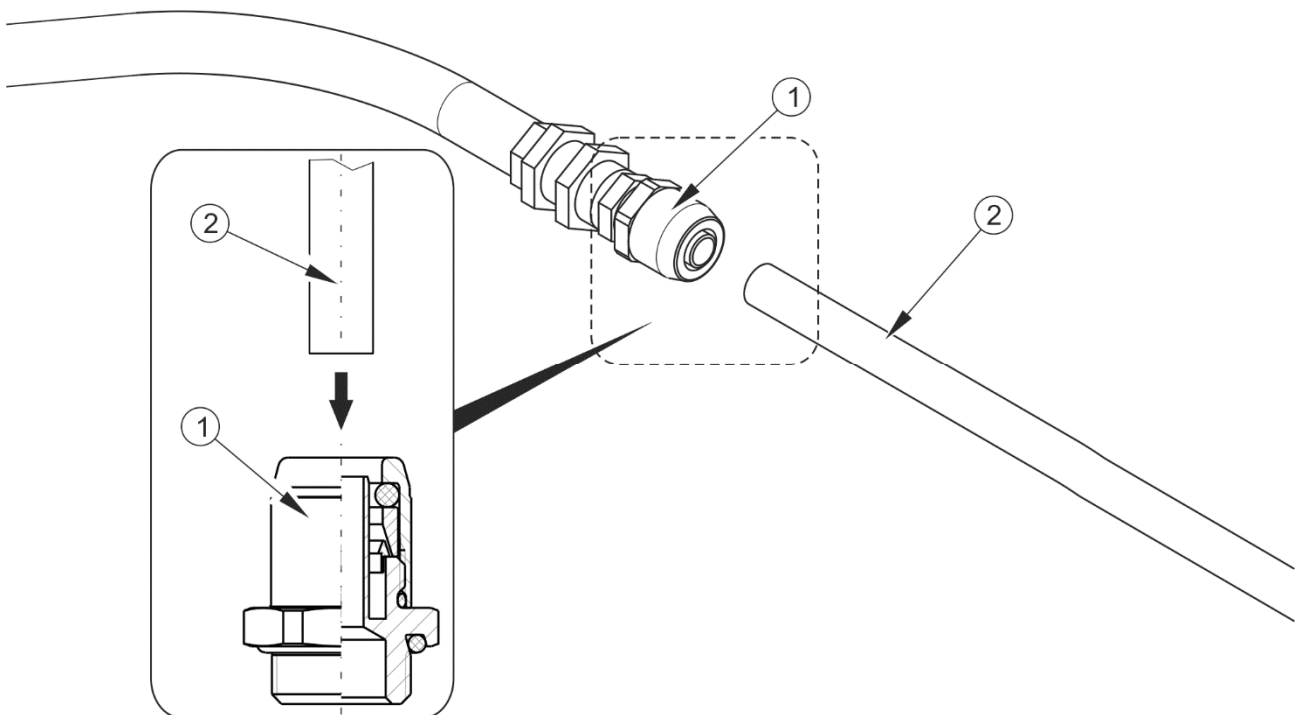

FIGURE 5.12 *Installation of pneumatic conduit*

(1) *push-in fitting, (2) pneumatic conduit*

TABLE 5.2 *Tightening torques for pneumatic system fittings*

PART NAME	THREAD	TIGHTENING TORQUE (NM)
Pneumatic system fittings	M22x1.5	24
	M14x1.5	30
	M16x1.5	35
	M18x1.5	36
	M22x1.5	40

5.4 HYDRAULIC SYSTEM MAINTENANCE

5.4.1 PRELIMINARY INFORMATION

Work connected with the repair, change or regeneration of hydraulic system components (tipping cylinder, valves etc.) should be entrusted to specialist establishments, having the appropriate technology and qualifications for this type of work.

The duties of the operator connected with the hydraulic system maintenance include:

- checking tightness and visual inspection of the system,
- checking technical condition of hydraulic connections.

DANGER



Do NOT tip trailer with unreliable hydraulic tipping system.

Do NOT use the trailer if hydraulic brake system is unreliable.

The hydraulic system is under high pressure when operating.

5.4.2 CHECK HYDRAULIC SYSTEM TIGHTNESS

Required maintenance activities

- ➔ Hitch trailer to tractor.
- ➔ Connect all hydraulic system conduits according to maintenance instructions.

- ➔ Clean connections and cylinders (tipping cylinder and possibly hydraulic brake system cylinder).
- ➔ Conduct test tipping of load box sideways and backwards.
- ➔ Press tractor brake pedal several times
 - ⇒ If trailer is equipped with hydraulic brake system (optional equipment).
- ➔ Check hydraulic cylinders and conduits for tightness.
- ➔ If leaks appear at connections then tighten the connections.

If oil leak is detected on hydraulic cylinder body, ascertain origin of leak. Inspect seals when hydraulic cylinder is completely extended. Minimum leaks are permissible with symptoms of "sweating", however in the event of noticing leaks in the form of "droplets" stop using the trailer until faults are remedied. If unreliability is evident in brake cylinder, do NOT use trailer with damaged system until faults are remedied.



Checking tightness:

- *after the first week of use,*
- *every 12 months of use.*

5.4.3 CHECKING TECHNICAL CONDITION OF HYDRAULIC CONNECTIONS AND SOCKETS.

Hydraulic connections must be technically reliable and kept clean. Each time before connecting, check if socket in tractor are maintained in good working condition. Hydraulic systems of tractor and trailer are sensitive to the presence of permanent contamination, which may cause damage to precision system components (contamination may cause jamming of hydraulic valves, scratching of cylinder surfaces etc.)



Inspection of hydraulic connections and sockets:

- *each time before hitching trailer to tractor.*

5.4.4 REPLACEMENT OF HYDRAULIC CONDUITS

Rubber hydraulic conduits must be replaced every 4 years regardless of their technical condition. This should be entrusted to specialised workshops.



Replacement of hydraulic conduits:

- every 4 years.

5.5 MAINTENANCE OF LIGHTING SYSTEM AND WARNING ELEMENTS

5.5.1 PRELIMINARY INFORMATION

Work connected with the repair, replacement or regeneration of lighting system components should be entrusted to specialist establishments which have the appropriate technology and qualifications for this type of work.

The duties of the user include only technical inspection of electrical system.



ATTENTION

Do NOT travel with out of order lighting system. Damaged lamp lenses, burnt-out bulbs and defective LEDs must be replaced immediately before travelling.

TABLE 5.3 *List of bulbs*

LAMP	LAMP TYPE	BULB / QUANTITY IN 1 LAMP	NUMBER OF LAMPS
Rear left lamp assembly	W 21L	R10W / 1 unit P21W / 2 pcs	1
Rear right lamp assembly	W 21P	R10W / 1 unit P21W / 2 pcs	1

Required maintenance activities

- ➔ Connect trailer to tractor with appropriate connection lead.
 - ⇒ Check if the connection lead is reliable. Check connection sockets in tractor and trailer. Clean and dry contaminated sockets.
- ➔ Check completeness and technical condition of trailer lights.
- ➔ Check correct mounting of the holder and slow-moving vehicle warning sign.
- ➔ Before driving on to public road, check that the tractor is equipped with a warning reflective triangle.



Checking technical condition of electrical system:

- *each time while connecting the trailer.*



TIP

Before driving away make certain that all lamps and warning elements are clean.

5.6 TRAILER LUBRICATION

Trailer lubrication should be performed with the aid of a manually or foot operated grease gun, filled with recommended grease. Before commencing work insofar as is possible remove old grease and other contamination. Remove and wipe off excess oil or grease.

Parts to be lubricated with machine oil should be wiped with dry clean cloth and then a small quantity of oil should be applied to surfaces (using oil can or brush). Wipe off excess oil.

Change of grease in hub bearings should be entrusted to specialised service points, equipped with the appropriate tools. According to the recommendations of the axle Manufacturer, dismantle the entire hub, remove the bearing and individual sealing rings. After careful washing and inspection, mount lubricated elements. If necessary, bearing and seals should be replaced with new parts. Lubrication of axle bearings shall be performed at least once in 2 years or every 50 000 km. In the event of intensive use, lubrication should be performed more frequently.

TABLE 5.4 *Trailer lubrication schedule*

ITEM	LUBRICATION POINT	NUMBER OF LUBRICATION POINTS	TYPE OF GREASE	FREQUENCY
1	Hub bearing	4	A	24M
2	Drawbar eye	1	B	14D
3	Expander shaft sleeve in drum hub	4	A	3M
4	Overrun drawbar components	1	B	1M
5	Sockets of tipping cylinder and cylinder suspension	4	B	1M
6	Tipping cylinder ball bearing	1	B	3M
7	Parking brake mechanism	1	A	6M
8	Parking brake guide roller pins	1	A	6M
9	Articulated joints and sockets for installation of load box.	4	B	2M
10	Side extension lug	10	A	1M
11	Slide gate guides	2	C	1M
12	Slide gate pull shaft pins	6	C	1M
13	Wall pins and locks	8	A	1M
14	Trailer support	1	A	6M

ITEM	LUBRICATION POINT	NUMBER OF LUBRICATION POINTS	TYPE OF GREASE	FREQUENCY
15	Side wall locking lever	2	A	6M

Lubrication periods – M months, D – days

TABLE 5.5 *Recommended lubricants*

MARKING ACCORDING TO TAB. (5.4)	DESCRIPTION
A	machine general-purpose grease (lithium, calcium grease),
B	permanent grease for heavily loaded elements with addition of MOS ₂ or graphite
C	ordinary machine oil, silicon grease in aerosol

Empty grease or oil containers should be disposed of according to the recommendations of the lubricant Manufacturer.

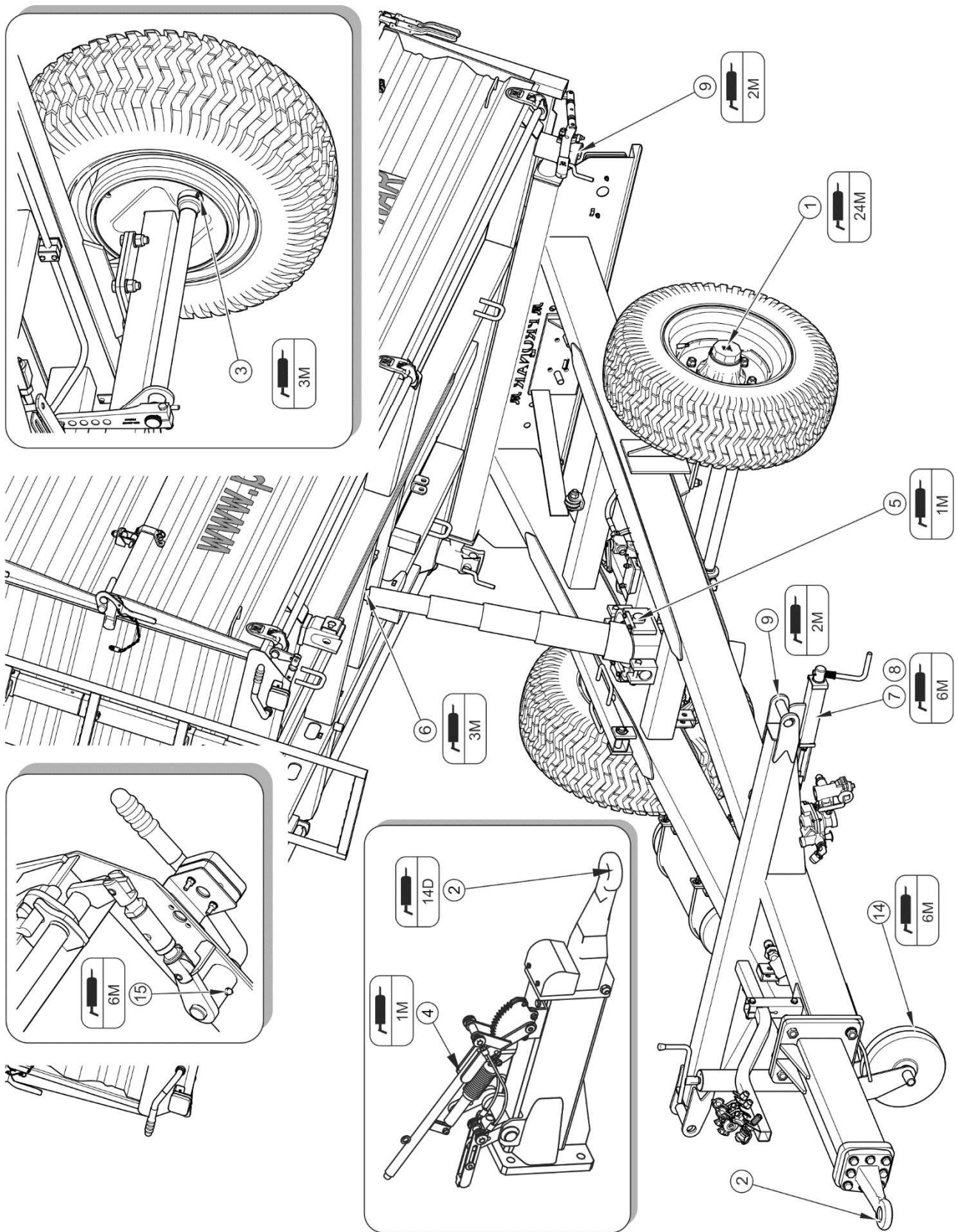

FIGURE 5.13 Trailer's lubrication points, part 1

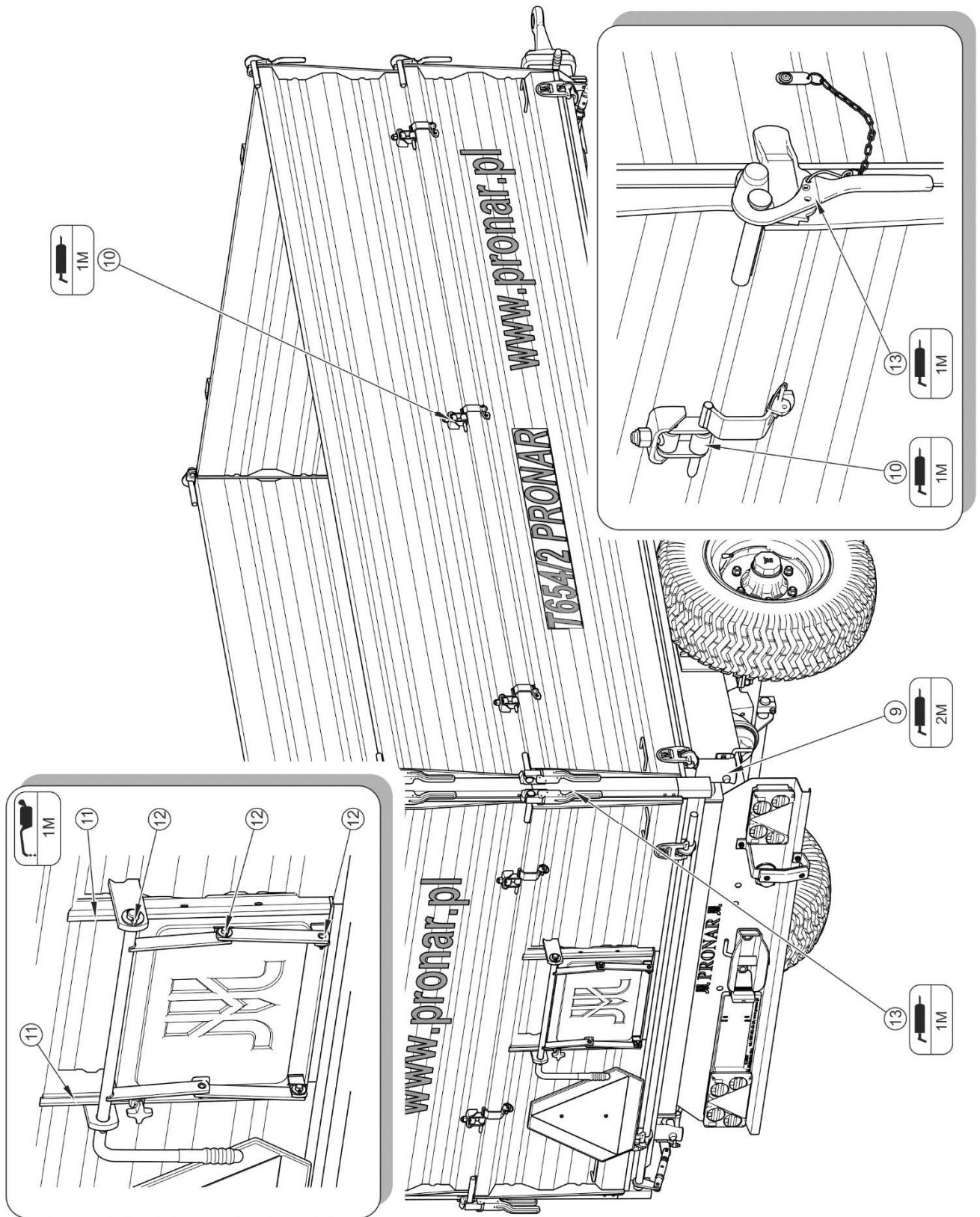

FIGURE 5.14 Trailer's lubrication points, part 2

5.7 CONSUMABLES

5.7.1 HYDRAULIC OIL



During trailer operation, the user is obliged to observe lubrication instructions according to attached lubrication schedule.

Always adhere to the principle that the oil in the trailer hydraulic system and in the tractor hydraulic system are of the same type. In the event of application of different types of oil make certain that both hydraulic substances may be mixed together. Application of different oil types may cause damage to trailer or tractor. In a new machine, the hydraulic system is filled with L HL32 Lotos hydraulic oil.

TABLE 5.6 *L-HL 32 Lotos hydraulic oil characteristics*

ITEM	NAME	UNIT	VALUE
1	ISO 3448VG viscosity classification	-	32
2	Kinematic viscosity at 40°C	mm ² /s	28.8 – 35.2
3	ISO 6743/99 quality classification	-	HL
4	DIN 51502 quality classification	-	HL
5	Flash-point	C	230

If it is necessary to change hydraulic oil for another oil, check the recommendations of the oil Manufacturer very carefully. If it is recommended to flush the system with the appropriate preparation, then comply with these recommendations. Attention should be given, so that chemical substances used for this purpose do not damage the materials of the hydraulic system. During normal trailer use change of hydraulic oil is not necessary, but if required, this operation should be entrusted to a specialist service point.

The oil applied because of its composition is not classified as a dangerous substance, however long-term action on the skin or eyes may cause irritation. In the event of contact of oil with skin wash the place of contact with water and soap. Do NOT apply organic solvents (petrol, kerosene). Contaminated clothing should be changed to prevent access of oil to skin. In the event of contact of oil with eye, rinse with large quantity of water and in the event of the

occurrence of irritation consult a doctor. Hydraulic oil in normal conditions is not harmful to the respiratory tract. A hazard only occurs when oil is strongly atomised (oil vapour), or in the case of fire during which toxic compounds may be released. Oil fires should be quenched with the use of carbon dioxide, foam or steam extinguishers. Do not use water to quench oil fires.

5.7.2 LUBRICANTS

For parts under great load it is recommended to apply lithium grease with molybdenum disulphide (MOS₂) or graphite additive. In the case of less loaded sub-assemblies the application of general purpose machine greases is recommended, which contain anticorrosive additives and have significant resistance to being washed away by water. Aerosol preparations (silicon greases and anticorrosive-lubricating substances) should have similar characteristics.

Before using the greases, read the information leaflet for a given product. Particularly relevant are safety rules and handling procedures for a given lubricant as well as waste disposal procedure (used containers, contaminated rags etc.). Information leaflet (material safety data sheet) should be kept together with grease.

5.8 CLEANING THE TRAILER

Trailer should be cleaned depending on requirements and before longer idle periods (e.g. before winter period). Before using pressure washer the user is obliged to acquaint himself with the operating principles and recommendations concerning safe use of this equipment.

Trailer cleaning guidelines

- Before washing trailer open all walls and extensions. Carefully clean load remains from the load box (sweep out or blow out with compressed air), especially where walls and extensions join.
- To clean the trailer, use only clean running water or water with a cleaning detergent additive with neutral pH.
- Using pressure washer increases washing effectiveness, but particular care must be taken during work. During washing, washer nozzle may not be closer than 50 cm from the surface being cleaned.

- Water temperature shall not exceed 55°C.
- Do not direct water jet directly at system elements and equipment of the trailer i.e. control valve, braking force regulator, brake cylinders, hydraulic cylinders, pneumatic, electric and hydraulic plugs, lights, electrical connections, information and warning decals, identification plate, conduit connections, lubrication points etc. Great water jet pressure may cause damage to these elements.
- For cleaning and maintenance of plastic coated surfaces it is recommended to use clean water or special preparations designed for this purpose.
- Do not apply organic solvents, preparations of unknown origin or other substances, which may cause damage to lacquered, rubber or plastic surfaces. In the event of doubt it is recommended to make a test on an unseen surface area.

DANGER

Carefully read the instructions for application of detergents and maintenance preparations.

While washing with detergents wear appropriate protective clothing and goggles protecting against splashing.

- Surfaces smeared with oil or grease should be cleaned by application of benzene or other degreasing agents and then washed with clean water with added detergent. Comply with recommendations of the Manufacturer of cleaning agents.
- Detergents should be kept in original containers, optionally in replacement containers, but very clearly marked. Preparations may not be stored in food and drink containers.
- Ensure cleanliness of elastic conduits and seals. The plastic from which these elements are made may be susceptible to organic substances and some detergents. As a result of long-term reaction of some substances, the ageing process may be accelerated and risk of damage increased. Rubber elements should be maintained with the aid of special preparations after previous thorough washing.

- After completed washing wait until the trailer is dry and then grease all inspection points according to recommendations. Remove excess oil or grease with a dry cloth.
- Observe environmental protection principles and wash trailer in a place designed for this purpose.
- Washing and drying trailer must take place at temperatures above 0°C.
- After washing and drying, trailer should be greased at all control points regardless of previous date of lubrication.

5.9 STORAGE

- Trailer should be kept in a closed or roofed building.
- If the machine will not be used for a long time, it is essential to protect it from adverse weather, especially rust and accelerated tyre deterioration. During this time the machine must be unloaded. Trailer should be very carefully washed and dried.
- Corroded places should be cleaned of rust, degreased and protected using undercoat paint and then painted with surface paint according to colour scheme.
- In the event of prolonged work stoppage, it is essential to lubricate all elements regardless of the date of the last lubrication.
- Wheel rims and tyres should be carefully washed and dried. During longer storage of unused trailer it is recommended that every 2 to 3 weeks the machine may be moved a bit so that the place of contact of tyres with ground is changed. The tyres will not be deformed and maintain proper geometry. Also, air pressure in tyres should be inspected from time to time and, if necessary, pressure should be increased to appropriate value.

5.10 TIGHTENING TORQUE FOR NUT AND BOLT CONNECTIONS

Unless other tightening parameters are given, during maintenance repair work apply appropriate torque to tighten nut and bolt connections. Recommended tightening torque for the most frequently used nut and bolt connections are given in table below. Given values apply to non-lubricated steel bolts.

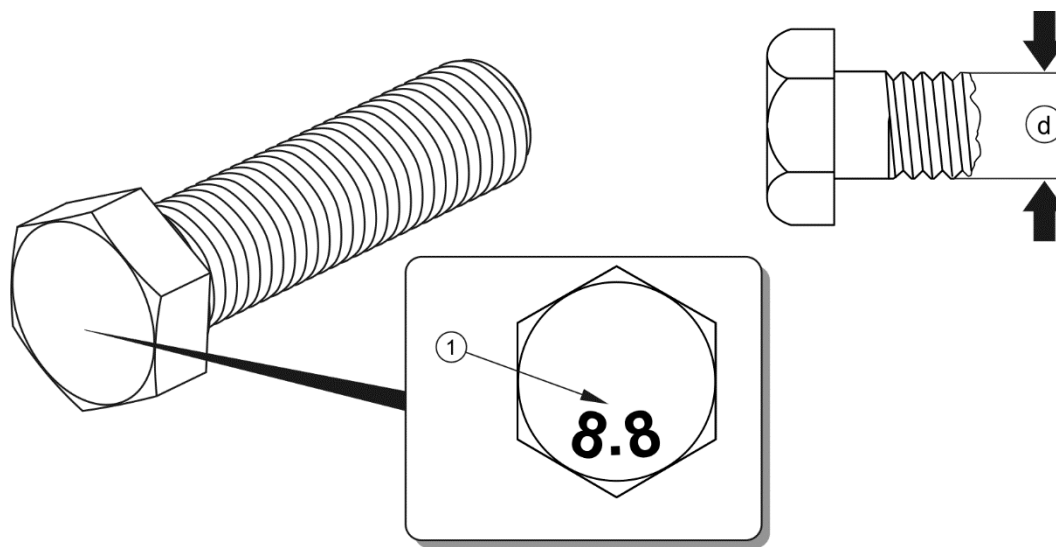

FIGURE 5.15 Bolt with metric thread

(1) strength class, (d) thread diameter

TABLE 5.7 Tightening torque for nut and bolt connections

THREAD METRIC	5.8 ⁽¹⁾	8.8 ⁽¹⁾	10.9 ⁽¹⁾
	Md [Nm]		
M10	37	49	72
M12	64	85	125
M14	100	135	200
M16	160	210	310
M20	300	425	610

THREAD METRIC	5.8 ⁽¹⁾	8.8 ⁽¹⁾	10.9 ⁽¹⁾
	Md [Nm]		
M24	530	730	1,050
M27	820	1,150	1,650
M30	1,050	1,450	2,100

(1) – strength class according to DIN ISO 898 standard

Hydraulic conduits should be tightened using torque of 50 – 70 Nm.

5.11 INSTALLATION AND DISASSEMBLY OF WALL EXTENSIONS

DANGER



Assembly and disassembly of wall extensions should be carried out with the use of appropriate platforms, ladders or when standing on a ramp. These tools must be in good condition to fully protect the persons working on them against falling. Work should be performed by at least two persons. Exercise particular caution.

Installation of wall extensions

- ➔ Secure rear wall extension stakes to rear wall stakes.
- ➔ Install front wall extension.
- ➔ Install rear wall extension.
- ➔ Install side wall extensions.
 - ⇒ First place upper pins of extension in appropriate locks of rear stakes and front wall, and after that, secure base of extension with the aid of hinge pins to upper part of side wall.
- ➔ Screw the ladder down.

Disassembly of wall extensions should be performed in reverse order.

5.12 TROUBLESHOOTING

TABLE 5.8 *Troubleshooting*

FAULT	CAUSE	REMEDY
Problem with moving off	Brake system conduits not connected	Connect brake conduits (applies to pneumatic systems)
	Applied parking brake	Release parking brake.
	Damaged pneumatic system connection conduits	Replace.
	Leaking connections	Tighten, replace washers or seal sets, replace conduits.
	Damaged control valve or brake force regulator	Check valve, repair or replace.
Noise in axle hubs	Excessive bearing slackness	Check slackness and adjust if needed
	Damaged bearings	Replace bearings
	Damaged hub parts	Replace
Poor reliability of braking system	Insufficient pressure in the system	Check pressure on tractor pressure gauge, wait till compressor fills tank to required pressure. Damaged air compressor in tractor Repair or replace. Damaged brake valve in tractor. Repair or replace. Leaking system conduits or connections. Check system for tightness.
	Incorrectly adjusted overrun brake	Adjust tension of overrun brake cable, check position of expander arms, adjust if necessary.
Excessive heating of axle hubs	Incorrect main or parking brake adjustment	Regulate positions of expander arms
	Worn brake linings	Change brake shoes

FAULT	CAUSE	REMEDY
Incorrect hydraulic system operation	Improper hydraulic oil viscosity	Check oil quality, make sure that the oil in both machines is of the same type. If necessary change oil in tractor or in trailer
	Insufficient tractor hydraulic pump output, damaged tractor hydraulic pump.	Check tractor hydraulic pump.
	Damaged or contaminated cylinder	Check cylinder piston rod (bending, corrosion), check cylinder for tightness (cylinder piston rod seal), if necessary, repair or replace the cylinder.
	Excessive cylinder loading	Check mechanism controlled by cylinder for mechanical damage
	Damaged hydraulic conduits	Check and ascertain that hydraulic conduits are tight, not fractured and properly tightened. If necessary, replace or tighten.

NOTES

A series of horizontal dotted lines for writing notes.



ANNEX A

Tyre dimensions

TRAILER VERSION	FRONT / REAR HALF AXLE
T654/2	11.5/80 – 15.3 16PR ⁽¹⁾ 15.0/55 - 17 14PR ⁽²⁾ 380/55 - 17 (144A6) ⁽²⁾

⁽¹⁾ - wheel disc 9.00x15.3"

⁽²⁾ - wheel discs 13.00x17" ET=30