



PRONAR Sp. z o.o.

17-210 NAREW, UL. MICKIEWICZA 101A, WOJ. PODLASKIE

tel.:	+48 085 681 63 29	+48 085 681 64 29
	+48 085 681 63 81	+48 085 681 63 82
fax:	+48 085 681 63 83	+48 085 682 71 10

www.pronar.pl

OPERATOR'S MANUAL

TRAILER

PRONAR T400

TRANSLATION OF THE ORIGINAL DOCUMENT

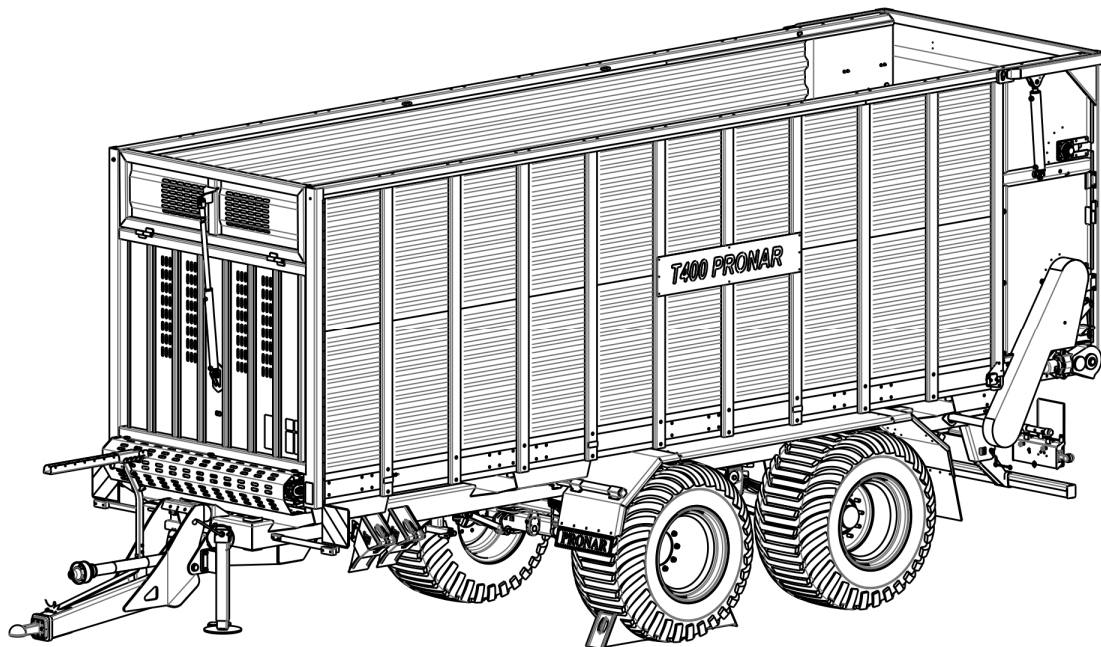

ISSUE 2A-11-2013

PUBLICATION NO. 252N-00000000-UM

EN

INTRODUCTION

Information contained herein is current at date of publication. As a result of improvements, some numerical values and illustrations contained in this publication may not correspond to the factual specification of the machine supplied to the user. The manufacturer reserves the right to introduce design changes in machines produced that facilitate operation and improve the quality of their work, without making minor amendments to this Operator's Manual.

This Operator's Manual is an integral part of the machine's documentation. Before using the machine, the user must carefully read this Operator's Manual and observe respect the recommendations. This guarantees safe operation and ensures failure-free work of the machine. The machine is designed to meet obligatory standards, documents and legal regulations currently in force.

The manual describes the basic principles of safe use and operation of the PRONAR T400 agricultural trailer. If the information contained in the Operator's Manual needs clarification then the user should refer for assistance of the sale point where the machine was purchased or to the Manufacturer.

MANUFACTURERS ADDRESS:

*PRONAR Sp. z o.o.
ul. Mickiewicza 101A
17-210 Narew*

TELEPHONE NUMBERS

+48 085 681 63 29

+48 085 681 64 29

+48 085 681 63 81

+48 085 681 63 82

SYMBOLS USED IN THE MANUAL

Information, description of threats and precautions as well as recommendations and orders connected with safety of use, in contents of the instruction, are distinguished with the sign:



or preceded with the word „**DANGER**". Non-compliance with recommendations described in the manual creates danger for life and health of operators or strangers.

Particularly important information and recommendations the observance of which is utterly necessary are distinguished in the text with this sign:



or preceded with the word „**ATTENTION**". Non-compliance with described recommendations is imminent damage of the machine due to improper service, adjustment or use.

In order to point out the necessity of performing periodic technical review of the machine, the content of particular paragraphs has been marked with the clock sign:



Additional instructions contained in the manual describe useful information regarding the operation of the machine and are marked with the following sign:



and preceded by the word "TIP".

DIRECTIONS USED IN THE OPERATOR'S MANUAL

Left side – side to the left hand of the operator facing in the direction of machine's forward travel.

Right side – side to the right hand of the operator facing in the direction of machine's forward travel.

SCOPE OF MAINTENANCE ACTIVITIES

The maintenance activities described in the manual are marked with the sign: ➡

The result of the service / adjustment task or comments on the performed task is marked with the sign: ⇨



PRONAR Sp. z o.o.

ul. Mickiewicza 101 A
17-210 Narew, Polska

tel./fax (+48 85) 681 63 29, 681 63 81, 681 63 82,
681 63 84, 681 64 29

fax (+48 85) 681 63 83

http://www.pronar.pl

e-mail: pronar@pronar.pl

EC DECLARATION OF CONFORMITY OF THE MACHINERY

PRONAR Sp. z o.o. declares with full responsibility, that the machine:

Description and identification of the machinery	
Generic denomination and function:	TRAILER
Type:	T400
Model:	-----
Serial number:	
Commercial name:	TRAILER PRONAR T400

to which this declaration relates, fulfills all the relevant provisions of the Directive **2006/42/EC** of The European Parliament and of The Council of 17 May 2006 on machinery, and amending Directive 95/16/EC (Official Journal of the EU, L 157/24 of 09.06.2006).

The person authorized to compile the technical file is the Head of Research and Development Department at PRONAR Sp. z o.o., 17-210 Narew, ul. Mickiewicza 101A, Poland.

This declaration relates exclusively to the machinery in the state in which it was placed on the market, and excludes components which are added and/or operations carried out subsequently by the final user.

Narew, the _____

Place and date

Z-CA DYREKTORA
d/s technicznych
członk zarządu

Roman Omelianiuk

*Full name of the empowered person
position, signature*

TABLE OF CONTENTS

1	BASIC INFORMATION	1.1
1.1	IDENTIFICATION	1.2
1.1.1	TRAILER IDENTIFICATION	1.2
1.1.2	DRIVE AXLE IDENTIFICATION	1.3
1.1.3	SERIAL NUMBERS LIST	1.3
1.2	INTENDED USE	1.4
1.3	EQUIPMENT	1.8
1.4	TERMS OF WARRANTY	1.9
1.5	TRANSPORT	1.11
1.5.1	CAR TRANSPORT	1.11
1.5.2	INDEPENDENT TRANSPORT	1.13
1.6	ENVIRONMENTAL HAZARD	1.13
1.7	DISPOSAL	1.14
2	USERS SAFETY	2.1
2.1	BASIC SAFETY RULES	2.2
2.1.1	TRAILER USE	2.2
2.1.2	SAFETY WHILE AGGREGATING THE MACHINE	2.3
2.1.3	SAFETY PRINCIPLES FOR HYDRAULIC AND PNEUMATIC SYSTEM OPERATION	2.4
2.1.4	WORKING WITH THE POWER TAKE-OFF (PTO)	2.5
2.1.5	PRINCIPLES OF SAFE DRIVING	2.6
2.1.6	LOADING AND UNLOADING OF THE TRAILER	2.9
2.1.7	TIRES	2.10
2.1.8	PRINCIPLES OF SAFE TECHNICAL OPERATION	2.11
2.2	RESIDUAL RISK	2.13
2.3	INFORMATION AND WARNING STICKERS	2.14

3	STRUCTURE AND PRINCIPLES OF OPERATION	3.1
3.1	TECHNICAL FEATURES	3.2
3.2	CHASSIS	3.3
3.3	LOADING PLATFORM	3.5
3.4	TAILGATE HYDRAULIC SYSTEM	3.7
3.5	FLOOR CONVEYOR MECHANISM HYDRAULIC SYSTEM	3.8
3.6	STEERING AXLE HYDRAULIC SYSTEM	3.10
3.7	TILTING FRONT WALL HYDRAULIC SYSTEM	3.11
3.8	PNEUMATIC BRAKES SYSTEM	3.12
3.9	DOSING DRUMS WITH POWER TRANSMISSION SYSTEM	3.16
3.10	PARKING BRAKE	3.17
3.11	WHEELS STEERING LOCK SYSTEM	3.18
3.12	LUBRICATION SYSTEM	3.19
3.13	ELECTRICAL AND LIGHTNING SYSTEM	3.21
4	PRINCIPLES OF USE	4.1
4.1	PREPARATIONS BEFORE FIRST START-UP	4.2
4.2	TECHNICAL CONDITION CONTROL	4.4
4.3	AGGREGATION WITH TRACTOR	4.5
4.3.1	SUPPORT FOOT HANDLING	4.7
4.4	LOADING	4.9
4.5	UNLOADING	4.12
4.6	TRANSPORT OF LOAD	4.14
4.7	DISCONNECTION FROM TRACTOR	4.15
4.8	PRINCIPLES OF TIRES USE	4.16

5	TECHNICAL SERVICE	5.1
5.1	BASIC INFORMATION	5.2
5.2	BRAKES AND AXLE SERVICE	5.2
5.2.1	BASIC INFORMATION	5.2
5.2.2	AXLE BEARING CLEARANCE CONTROL	5.3
5.2.3	AXLE BEARING CLEARANCE ADJUSTMENT	5.5
5.2.4	MOUNTING AND DISMOUNTING THE WHEEL, CHECKING BOLT CONNECTIONS	5.6
5.2.5	AIR PRESSURE CONTROL, TIRES AND RIMS TECHNICAL CONDITION INSPECTION	5.9
5.2.6	CHECKING THE BRAKE LINING WEAR	5.10
5.2.7	MECHANICAL BRAKES REGULATION	5.11
5.2.8	PARKING BRAKE STRING REPLACEMENT AND TENSNESS REGULATION	5.15
5.3	PNEUMATIC SYSTEM SERVICE	5.17
5.3.1	BASIC INFORMATION	5.17
5.3.2	AIRTIGHTNES CONTROL AND VISUAL INSPECTION	5.17
5.3.3	CLEANING THE AIR FILTERS	5.19
5.3.4	DRAINAGE OF AIR TANKS	5.20
5.3.5	CLEANING OF DRAIN VALVE	5.21
5.3.6	CLEANING AND MAITAINANCE OF PNEUMATIC LINE CONNECTORS AND SOCKETS	5.22
5.3.7	REPLACING PNEUMATIC LINES	5.23
5.4	HYDRAULIC SYSTEM SERVICE	5.24
5.4.1	BASIC INFORMATION	5.24
5.4.2	HYDRAULIC SYSTEM TIGHTNESS CONTROL	5.25
5.4.3	CONTROL OF TECHNICAL CONDITION OF HYDRAULIC CONNECTORS AND SOCKETS	5.26
5.4.4	HYDRAULIC HOSES REPLACEMENT	5.26
5.5	SUSPENSION SERVICE	5.27

5.6 ELECTRICAL INSTALATION AND WARNING COMPONENTS SERVICE	5.29
5.6.1 BASIC INFORMATION	5.29
5.6.2 LIGHT BULBS REPLACEMENT	5.31
5.7 LUBRICATION	5.31
5.8 CONSUMABLES	5.36
5.8.1 HYDRAULIC OIL	5.36
5.8.2 LUBRICANTS	5.37
5.9 TRAILER CLEANING	5.38
5.10 STORAGE	5.39
5.11 FLOOR CONVEYOR CHAINS TENSION REGULATION	5.41
5.12 CHAIN TRANSMISSION SERVICE	5.43
5.13 TRANSMISSION SERVICE	5.45
5.14 TIGHTENING TORQUE OF BOLT CONNECTIONS	5.46
5.15 TROUBLESHOOTING	5.47

CHAPTER

1

BASIC INFORMATION

1.1 IDENTIFICATION

1.1.1 TRAILER IDENTIFICATION

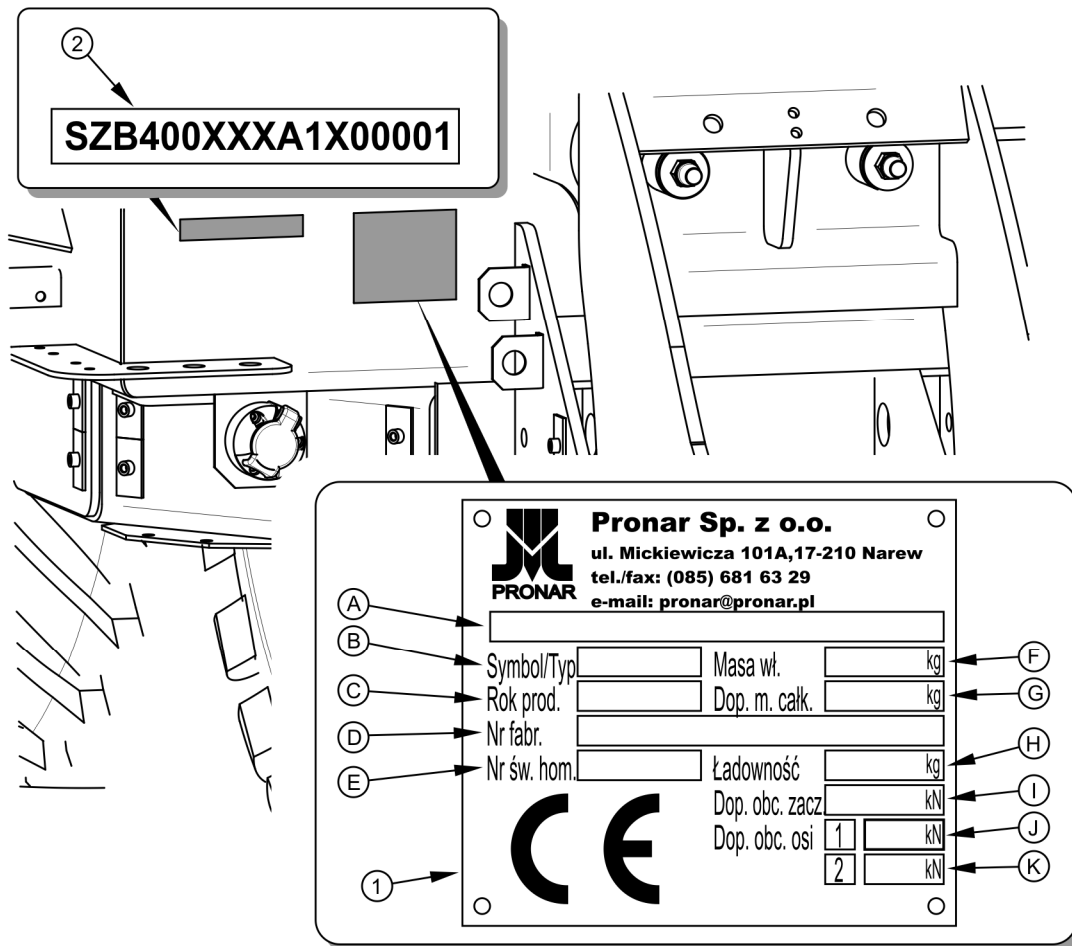

Figure 1.1 Location of the type plate and serial number

(1) type plate, (2) serial number

Trailer PRONAR T400 is marked with the type plate (1), placed on the front beam of the loading box and serial number (2) placed on a rectangular shaped field painted in gold. When purchasing the machine, check the conformity of serial numbers on the machine with the number written in the Warranty Card, the sales documents and the User’s Manual.

The meaning of individual fields on the type plate – figure (1.1) is shown in table (1.1).

Table 1.1 Type plate markings

NO.	MEANING
A	General description and function
B	Trailer symbol / type
C	Year of production
D	VIN number
E	Approval certificate number
F	Unladen weight
G	Permissible laden mass
H	Load capacity
I	Permissible load on the coupling
J	Permissible load axle 1
K	Permissible load axle 2

1.1.2 DRIVE AXLE IDENTIFICATION

The serial number of the drive axle and its type are stamped on the type plate attached to the driving axle beam. In case of ordering spare parts, it is required to provide the trailer serial number and axle type.

1.1.3 SERIAL NUMBERS LIST

VIN NUMBER

S	Z	B	4	0	0	0	X	X			X						
---	---	---	---	---	---	---	---	---	--	--	---	--	--	--	--	--	--

SERIAL NUMBER – AXLE 1

--

SERIAL NUMBER – AXLE 2

--

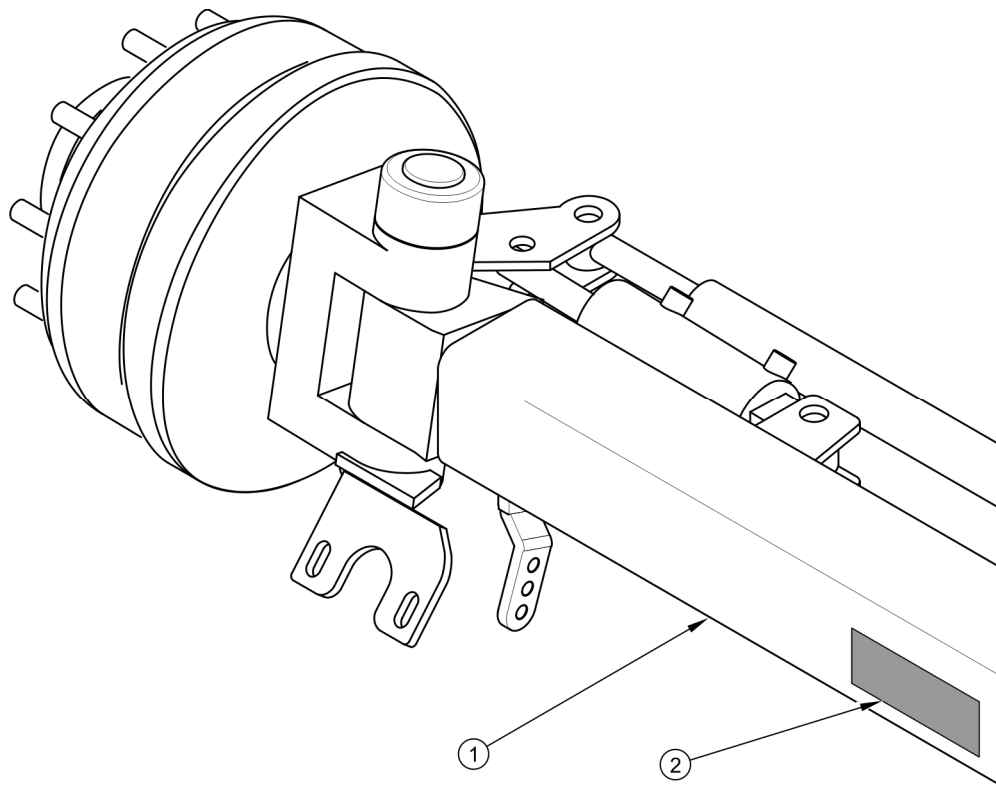

Figure 1.2 Location of the drive axle type plate

(1) drive axle beam, (2) type plate



TIP

In case of ordering spare parts or any problems it is often necessary to provide serial numbers of components or trailer VIN number, as for that, it is recommended to fill in those numbers in the fields above.

1.2 INTENDED USE

Trailer T400 is intended for transport of voluminous agricultural products including green fodder, mulches, fodder, hay, straw, leaves, chaff, silage. A detailed list of materials for transport is provided in table (4.2). Due to the construction of the loading platform, the transported products must be loaded using self-propelled harvesters, loaders, tractor loaders or conveyors.

The trailer can also be used in corn harvesting technology using self-propelled forage harvesters. The trailer is used to collect chopped maize from the forage harvester and

transport it to the ensilage forage. The machine can be used as a trailer accompanying self-propelled harvesters adapted for harvesting green swaths or biomass.

The trailer is adapted to transport voluminous materials within the farm and on public roads with a maximum speed of 40 km / h.

It is not allowed to use the trailer in a different way than described above. Intended use also includes all activities related to proper and safe operation and maintenance. The trailer is not intended for transporting people and animals.

It is allowed to transport other volumetric loads provided that the requirements set out in Chapter 4 are met. Non-compliance with the recommendations for the carriage and loading of goods specified by the Manufacturer and road transport regulations in force in the country in which the trailer is used will void the warranty services and shall be treated as the use of the machine not according to the intended use.

The braking system as well as the lighting and signaling system meet the requirements set out in traffic regulations. The maximum speed of a trailer traveling on public roads in Poland is 30 km / h (in accordance with the Act of 20 June 1997, "Prawo o Ruchu Drogowym", art. 20). In countries where the trailer is used, restrictions related to the road traffic laws in force in a given country must be respected. The trailer speed must not, however, be greater than the maximum design speed of 40 km / h.

The chassis equipment (axles, wheels and tires) meets the requirements for agricultural trailers. The user of the trailer is obliged to read this manual and follow its recommendations.

Intended use also includes all activities related to the correct and safe operation and maintenance of the machine. Therefore, the user is obliged to:

- become acquainted with the contents of the *OPERATOR'S MANUAL* and the *WARRANTY CARD* and comply with the recommendations contained in these publications,
- understand the principle of machine operation and the safe and proper operation of the trailer,
- comply with established maintenance and adjustment plans,
- comply with general safety regulations during work,
- accident prevention,

- comply with traffic regulations and transport regulations in force in the country where the trailer is used,
- become acquainted with the contents of the farm tractor instruction manual and comply with its recommendations,
- aggregate the vehicle only with such an agricultural tractor, that meets all the requirements set by the trailer manufacturer.

ATTENTION

The trailer may not be used for purposes other than those for which it is intended. In particular, it is prohibited to:



- • transport people, animals, hazardous materials, loads having a destructive effect on trailer structural elements as a result of chemical reactions (causing corrosion of steel, damaging paint coverings, dissolving plastic elements, destroying rubber elements, etc.),
- transporting an improperly secured load that could cause road littering and environmental pollution while driving,
- carrying a load which location negatively affects the center of gravity and thus, stability of the trailer,
- carrying loads that cause uneven loading and / or overloading of the axles and suspension components.

The trailer may only be used by persons who:

- become acquainted with the content of publications and documents attached to the trailer and the contents of the farm tractor operating instructions,
- have been trained or have acquired appropriate knowledge in the field of trailer operation and work safety,
- have the required authorization to drive and are familiar with the traffic rules and transport regulations.

Table 1.2 Requirements for the agricultural tractor

DESCRIPTION	UNIT	REQUIREMENT
Braking system Two-line pneumatic system Maximum system pressure	- bar / kPa	According to PN-ISO 1728:2007 8 / 800
Hydraulic system Hydraulic oil Installation nominal pressure Oil demand / pump performance	- bar / MPa l / l/min	L HL 32 Lotos ⁽¹⁾ 160 / 16 10 / 90
Electrical installation Electrical system voltage Connection socket	V -	12 7 pole according to ISO 1724
Tractor coupling Permissible vertical load on the coupling device Tractor hitch required	kg -	2 000 Bottom coupling for one-axle trailers
Other requirements PTO rotation speed PTO rotation direction Minimal tractor power	rpm kW / KM	540 Clockwise (looking at the forehead of the shaft) 118 / 160

⁽¹⁾ – the use of other oil is allowed provided it can be mixed with oil in the trailer. Detailed information can be found in the product information card.

**TIP**

Tractor requirements depend on trailer completion.

1.3 EQUIPMENT

Some standard equipment items that are listed in table (1.3) may not be included in the trailer supplied. This is due to the possibility of ordering a new machine with a different set - optional equipment, replacing the standard equipment.

Tire information is provided at the end of the publication in *ANNEX A*.

Table 1.3 Trailer equipment

EQUIPMENT	STANDARD	ADDITIONAL	OPTIONAL
Operator's manual	•		
Warranty card	•		
Electrical connection cable	•		
Two-line pneumatic system with manual regulator	•		
Two-line pneumatic system with automatic regulator			•
Tilting front wall hydraulic installation	•		
Tailgate hydraulic system	•		
Hydraulic powered dosing mechanism	•		
Mudguards set	•		
Support foot with mechanical gear	•		
Drawbar with shock-absorber	•		
Turnable towing eye Ø50 mm	•		
Wheel chocks	•		
Tool box	•		
Rear coupling		•	

EQUIPMENT	STANDARD	ADDITIONAL	OPTIONAL
SMV rear marking plate		•	
Retro reflecting triangle		•	
Lubrication system	•		
Bottom ball coupling Ø80			•
Dosing drums for green fodder		•	
Dosing drums for chopped maize		•	
Power transmission mechanism		•	
Loading box tightening strings	•		

Drive shafts used in the machine starting from the front of the trailer:

- Telescopic drive shaft 7106121CE007007 - manufacturer: Bondioli & Pavesi, (connecting trailer to the tractor)
- Drive shaft with automatic clutch 7105121CE00719A - manufacturer: Bondioli & Pavesi,
- Telescopic drive shaft 7105121CE007096 - manufacturer: Bondioli & Pavesi,
- Telescopic drive shaft 7105121CE007007 - manufacturer: Bondioli & Pavesi,

1.4 TERMS OF WARRANTY

PRONAR Sp. z o.o. in Narew guarantees reliable operation of the machine when used in accordance with the technical and operational conditions described in the *OPERATOR'S MANUAL*.

The time required to carry out the repair is given in the *WARRANTY CARD*.

The warranty does not apply to parts and sub-assemblies of the machine, which are subject to wear in normal operating conditions, regardless of the warranty period. The group of these elements includes min. the following parts / components:

- Drawbar towing eye,
- filters on pneumatic system connectors,
- tires,
- brake shoes,
- lightning bulbs and LED lamps,
- seals,
- chains,
- gears,
- bearings.

The warranty services only apply to such cases as: mechanical damage not caused by the fault of the user, factory defects of parts, etc. In the event that damage arises as a result:

- mechanical damage caused by the user's fault, road accident,
- from improper operation, adjustment and maintenance, using the trailer contrary to its intended use,
- using a damaged or inoperative machine,
- carrying out repairs by unauthorized persons, incorrect repairs,
- making arbitrary changes in the machine design,

the user loses the warranty service.



TIP

Demand that the seller carefully and precisely fills out the Warranty Card and complaint coupons. The lack of e.g. date of sale or point of sale stamp exposes the users possible complaints not to be accepted.

The user is obliged to immediately report all noticed defects in the paint coatings or traces of corrosion, and to order the removal of defects regardless of whether the damage is covered

by the warranty or not. Detailed warranty conditions are given in the WARRANTY CARD attached to the newly purchased machine.

Modifications of the trailer without the written consent of the Manufacturer are prohibited. In particular, welding, reaming, cutting and heating of the main machine components that directly affect safety during use are not permitted.

1.5 TRANSPORT

The trailer is ready for sale completely assembled and does not require packing. Only the machine's technical documentation and any additional equipment may be packed. Delivery to the user takes place by car or independent transport (towing a trailer with an agricultural tractor).

1.5.1 CAR TRANSPORT

Loading and unloading the trailer from a car should be carried out using a loading ramp and a farm tractor. During work the general principles of workplace health and safety of reloading should be respected. Person operating reloading equipment must have the required permissions to use these devices. The trailer during loading must be correctly connected to the tractor in accordance with the requirements contained in this operator's manual. The trailer braking system must be activated and checked before going down or onto the ramp.

The trailer should be mounted firmly on the platform of the vehicle using straps, chains, lashings or other fastening devices equipped with a tensioning mechanism. The fastening elements should be attached to the transport eyelets designed for this purpose (1) - figure (1.3), or to the permanent structural elements of the trailer (longerons, crossbars, etc.). Transport brackets are welded to the bottom frame crossbeams (2), one pair for each trailer crossbeam. Use certified and technically reliable securing measures. Wiping belts, cracked fasteners, bent or corroded hooks or other damage may disqualify the product from being used. Please refer to the directions in the manufacturer's instructions for the fastener used. Chocks, wooden beams or other objects without sharp edges should be placed under the trailer wheels, protecting the machine against rolling away. Trailer wheel blocks must be nailed to the load platform planks of the car or secured in another way preventing their movement. The number of fastening elements (ropes, belts, chains, lashings etc.) and the force needed for their tension depends, among others, on the trailer's own weight, the design

of the car carrying the trailer, the speed of travel and other conditions. Therefore, it is not possible to specify the fastening plan in detail. A properly attached trailer will not change its position relative to the transporting vehicle. The fastening means must be selected according to the manufacturer's instructions.

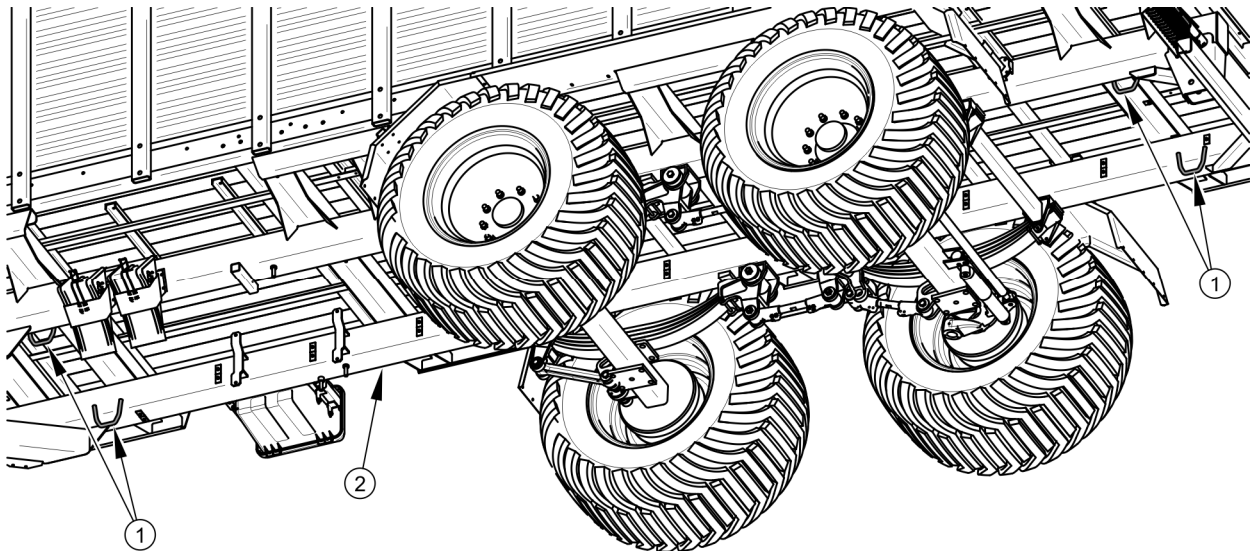

Figure 1.3 Transport brackets positioning

(1) transport bracket, (2) lower frame crossbeams

ATTENTION



During road transport, the trailer must be mounted on the platform of the vehicle in accordance with safety requirements and regulations.

While driving, the car driver should maintain extreme caution. This is due to the fact that the center of gravity of the vehicle with the loaded machine is shifted upwards.

Use only approved and technically reliable securing measures. Read the operating instructions of the fastener manufacturer.

In case of doubt, a greater number of attachment and securing points for the trailer should be used. If necessary, protect the sharp edges of the trailer, thus securing the fastening means against damage during transport.

During reloading work, particular attention should be paid so as not to damage the machine equipment components and the paint coating. The own weight of the trailer in running order is given in table (3.1).

**DANGER**

Incorrect use of securing measures can be a cause of an accident.

1.5.2 INDEPENDENT TRANSPORT

In the case of independent transport by the user after purchasing the trailer, carefully read the contents of this OPERATOR'S MANUAL. Follow all instructions in this publication. Independent transport involves towing a trailer with your own agricultural tractor to its destination. While driving, adjust the speed to the prevailing road conditions, it must not be greater than the maximum design speed.

**ATTENTION**

When transporting independently, the tractor operator should read the contents of this manual and respect the recommendations contained therein.

1.6 ENVIRONMENTAL HAZARD

A hydraulic oil leak creates a direct threat to the natural environment because of the limited biodegradability of the substance. Due to the low solubility of oil in water, it does not cause high toxicity of living organisms. An oil leak into water reservoirs can, however, lead to a reduction in oxygen content. Performing maintenance and repair work where there is a risk of leakage, should be carried out in rooms with oil resistant surfaces. In case of oil leakage into the environment, first of all contain the source of the leak, and then collect the leaked oil using available means. Collect oil residue with sorbents or mix the oil with sand, sawdust or other absorbent materials. Collected oil contaminants should be stored in an airtight and marked container, resistant to hydrocarbons. The container should be kept away from heat sources, flammable materials and food.

**DANGER**

Used hydraulic oil or collected remains mixed with absorbent material should be stored in a precisely marked container. Do not use food packaging for this purpose.

Oil which has been used up or is unsuitable for further use due to the loss of its properties is recommended to be stored in its original packaging in the same conditions as described previously. Oil waste should be taken to an oil disposal or regeneration point. Waste code: 13 01 10. Detailed information on hydraulic oil can be found in the product safety data sheet.

**ATTENTION**

Oil waste can only be brought to a point dealing with the utilization or regeneration of oils. It is forbidden to throw or pour oil into the sewage system, water reservoirs or directly on the ground.

**TIP**

The trailer's hydraulic system is filled with L-HL 32 Lotos oil.

1.7 DISPOSAL

If the user decides to withdraw the trailer from use, comply with the provisions in force in the given country regarding withdrawal from use and recycling of machines withdrawn from use. Before disassembly, remove all oil from the hydraulic system and completely reduce air pressure in the pneumatic braking systems (e.g. by means of the air tank drain valve).

**DANGER**

During disassembly, use appropriate tools and use personal protective equipment, i.e. protective clothing, footwear, gloves, glasses, etc. Avoid oil contact with skin. Do not allow hydraulic oil to leak.

In the event of parts being replaced, worn or damaged parts that cannot be regenerated or repaired should be sent to a recycling center. Hydraulic oil should be taken to the appropriate facility dealing with the utilization of this type of waste.

CHAPTER

2

USERS SAFETY

2.1 BASIC SAFETY RULES

2.1.1 TRAILER USE

- Before using the trailer, the user should carefully read the content of this publication. During the operation all the recommendations contained in it must be respected.
- The trailer may only be used and operated by person authorized to drive agricultural tractors with a trailer.
- The trailer user is obliged to become familiar with the construction, principle of operation and safe operation of the trailer.
- If the information contained in the Operator's Manual is difficult to understand, contact a seller who runs an authorized technical service on behalf of the manufacturer, or contact the manufacturer directly.
- Careless and improper use and operation of the trailer, non-observance of the recommendations contained in these instructions creates a threat to health.
- Be aware of the existence of a residual risk of danger, therefore the application of the principles of safe use and reasonable behavior should be the basic principle of using the trailer.
- It is forbidden to use the machine by persons who are not authorized to drive agricultural tractors, including children, people under the influence of alcohol or other drugs.
- Non-compliance with the rules of safe use creates a risk to health for the operator and bystanders.
- The trailer may not be used for purposes other than those for which it was intended. Anyone who uses the trailer in a manner inconsistent with its intended use, thus takes full responsibility for all consequences arising from its use. Use of the machine for purposes other than specified by the Manufacturer is inconsistent with the purpose of the machine and may void the warranty.

- The trailer may only be used when all the covers and other protective components are technically functional and correctly positioned. If the covers are damaged or lost, they must be replaced with new ones.
- Before using the trailer always check its technical condition. In particular, check the technical condition of the hitch system, chassis, the braking system and the traffic lights as well as the tension of the conveyor chain.
- Climbing on the machine is only allowed when the trailer is absolutely stationary and the tractor engine is switched off.

2.1.2 SAFETY WHILE AGGREGATING THE MACHINE

- Before connecting the trailer to the agricultural tractor, check the technical condition of the machine and tractor hitching system, drive shaft, and connecting elements of the hydraulic, pneumatic and electric system.
- It is forbidden to connect the trailer to the tractor if it does not meet the relevant requirements. Before connecting the machine, make sure that the oil in both machines can be mixed.
- Before connecting the trailer, make sure that the agricultural tractor and trailer are technically functional.
- When connecting the trailer to the tractor, use the appropriate hitch for single-axle trailers. After completing the coupling of the machine check the safety of the hitch. Read the tractor operating instructions.
- Be especially careful when connecting the machine. Ensure proper visibility. When hitching up, nobody is allowed to stay between tractor and the trailer.
- When repairing the trailer, uncoupling it from the tractor is forbidden, the rear tailgate must be additionally secured against closing. When unhitching the trailer, take particular care.
- Hitching and unhitching the trailer may only take place when the machine is immobilized with the parking brake.
- After completing the coupling of the trailer, the drawbar support foot should be raised to transport position.

- When setting the support in driving or resting position, do not put your hands between the moving parts of the support. Make sure that the support is properly locked with a bolt.

2.1.3 SAFETY PRINCIPLES FOR HYDRAULIC AND PNEUMATIC SYSTEM OPERATION

- The hydraulic system is under high pressure during operation.
- Regularly check the technical condition of connections and hydraulic and pneumatic conduits. Oil leaks and air leaks are not permitted.
- In the case of hydraulic or pneumatic system failure, the trailer should be decommissioned until the failure is eliminated.
- When connecting the hydraulic conduits to the tractor, make sure that the tractor and trailer hydraulic systems are not under pressure. If necessary, reduce the residual pressure of the system.
- In the event of injuries being caused by pressurized hydraulic oil, contact a doctor immediately. Hydraulic oil can penetrate the skin and cause infection. In the event of contact of oil with eyes, rinse with large quantity of water and in the event of the occurrence of irritation consult a doctor. In the event of contact of oil with skin, wash the area of contact with water and soap. Do not use organic solvents (gasoline, kerosene).
- Use the hydraulic oil recommended by the manufacturer. Never mix two oil types.
- After changing the hydraulic oil, the used oil must be disposed of. Used oil or oil which has lost its properties should be stored in original containers or replacement packaging resistant to hydrocarbons. Replacement containers must be accurately described and properly stored.
- It is forbidden to store hydraulic oil in packaging intended for food storage.
- Rubber hydraulic hoses must be replaced every 4 years regardless of their technical condition.
- Check the condition of the machine's hydraulic system frequently, oil leaks are not allowed.

2.1.4 WORKING WITH THE POWER TAKE-OFF (PTO)

- Before starting work, become acquainted with the drive shaft operating instructions provided by the shaft manufacturer and follow the recommendations contained therein.
- The trailer may be connected to the tractor only by means of a suitably selected articulated telescopic shaft, recommended by the Manufacturer.
- The drive shaft must be equipped with covers. It is forbidden to use the shaft with damaged or missing safety elements.
- After installing the shaft make sure that it is correctly and securely connected to the tractor and trailer.
- It is forbidden to wear loose clothing, loose belts or anything that could get caught in the rotating shaft. Contact with rotating PTO shaft may cause serious injury.
- Before disconnecting the shaft, turn off the tractor engine and remove the key from the ignition.
- When working in conditions of limited visibility, the drive shaft and its surroundings should be illuminated with the help of tractor work lights.
- During transport, the shaft should be stored in a horizontal position to avoid damage to guards and other safety elements.
- When using the shaft and trailer, do not use PTO shaft speed other than 540 rpm. It is forbidden to overload the shaft and machine as well as to engage the clutch suddenly. Before starting PTO shaft make sure that the PTO rotation direction is correct.
- • It is forbidden to walk over and under the shaft and stand on it both during work and when the trailer is stationary.
- The PTO shaft has markings on the housing, indicating which end of the shaft should be connected to the tractor.
- Never use a damaged PTO shaft as it may cause an accident. A damaged shaft must be repaired or replaced.

- Disconnect the drive shaft each time when there is no need to drive the machine, or when the tractor and trailer are in an unfavorable angular position with respect to each other.
- The safety chain of the shaft cover must be secured against turning while the shaft is working, it should be secured to a permanent structural element of the trailer.
- It is forbidden to use safety chains to support the shaft during standstill or transporting the trailer.

2.1.5 PRINCIPLES OF SAFE DRIVING

- When driving on public roads, comply with the road traffic regulations in force in the country where the trailer is used.
- Do not exceed the maximum design speed.
- Adjust the speed to the conditions on the road.
- It is forbidden to leave the machine unsecured. The trailer disconnected from the tractor must be immobilized with the parking brake and secured against rolling away with wheel chocks.
- Before driving off make sure that the trailer is correctly connected to the tractor, especially whether the drawbar eye is secured.
- Vertical load carried by the trailer drawbar eye affects the steering functions of the agricultural tractor.

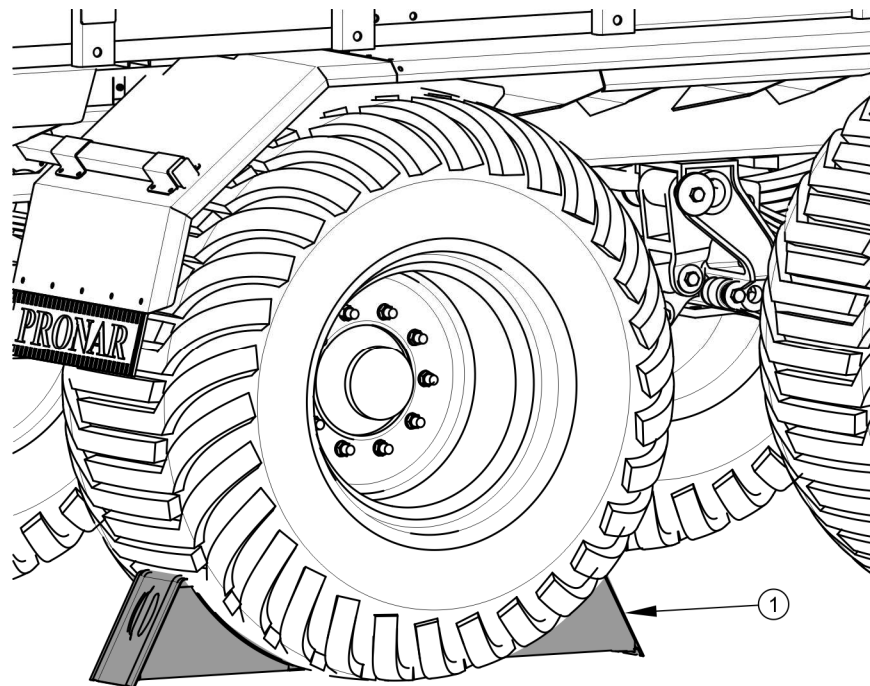

Figure 2.1 Wheel chocks placement

(1) wheel chock

- Chocks should only be placed under one wheel (one in front of the wheel, the other in the back – figure (2.1)). Chocks should not be placed under the wheel of the rear steering axle.
- It is forbidden to drive with the tailgate raised.
- Before using the trailer always check its technical condition. In particular, check the technical condition of the hitch system, the chassis, the braking system and traffic lights as well as the connecting elements of the hydraulic, pneumatic and electrical systems.
- Before driving, check that the parking brake is released and the braking force regulator is in the correct position (applies to manual, three-position regulators).
- The trailer is adapted for driving on slopes up to a maximum of 8°, provided that special care is taken and speed is adapted to the driving conditions. It is recommended to reduce the speed when turning back and not make sudden maneuvers.

- Periodically drain air tanks in the pneumatic system. During hoarfrost, freezing water may cause damage to system components.

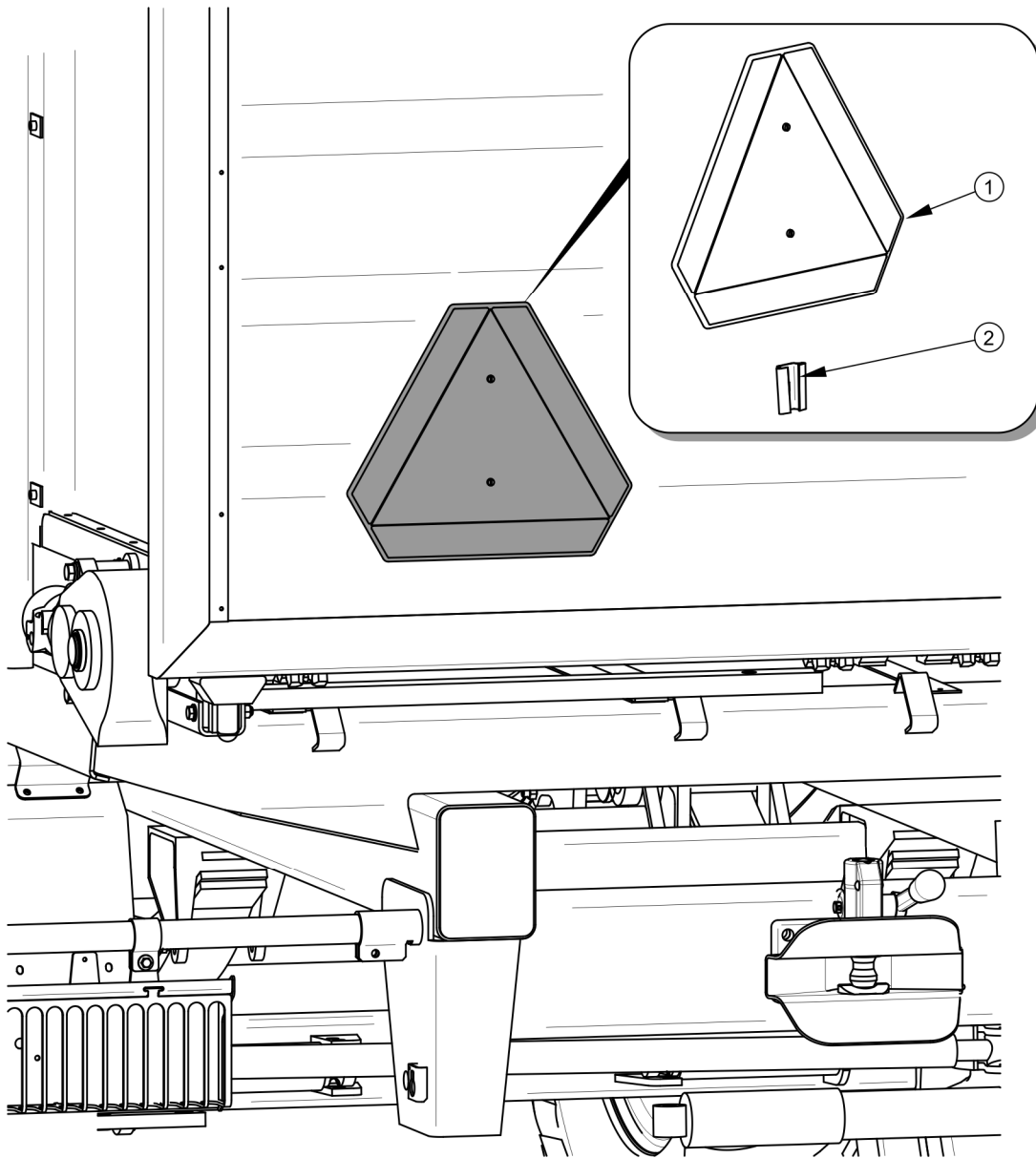

Figure 2.2 SMV rear marking plate placement

(1) SMV plate (2) plate mounting

- When driving on public roads, the tractor operator must ensure that the trailer and tractor have a certified or approved warning reflective triangle.
- A SMV (slow moving vehicles) marking plate should be placed on the tailgate - figure (2.2).
- Reckless driving and excessive speed can cause accidents.

- The load must be secured so that it cannot move.
- Before driving off make sure that the support is in driving position and secured.
- It is forbidden to transport unauthorized loads as well as people and animals on the trailer.
- The trailer's maximum load capacity must not be exceeded. Exceeding the load capacity may lead to damage of the machine, loss of stability while driving and cause a hazard while driving.
- The braking system was designed for permissible total weight of the trailer.
- Exceeding the permissible total weight will reduce braking performance.
- The load on the trailer must be evenly distributed and must not hinder driving.
- It is recommended to use the help of another person when reversing. During maneuvers, the assisting person must keep a safe distance from danger zones and be visible to the tractor operator at all times.
- Pay attention so that nobody gets on the trailer while driving.
- It is forbidden to park the trailer on a decline.

2.1.6 LOADING AND UNLOADING OF THE TRAILER

- Loading work should be carried out by a person experienced in this type of work.
- The arrangement of the load must not cause an overload on the chassis and the hitch system of the trailer and tractor.
- Incorrectly selected load distribution and overloading the machine may cause the trailer to tip over or cause damage to its components.
- It is forbidden to stay in the load box during loading and unloading.
- The load may not protrude beyond the upper edge of the trailer's front wall. The load must be arranged so that it does not endanger the stability of the machine.
- During loading or unloading the trailer must be coupled with the tractor and set for straight-ahead driving. When loading from a combine harvester, be especially cautious and maintain a constant distance to allow free loading.

- Make sure that there are no bystanders in the unloading area or the tailgate being raised. Ensure proper visibility before unloading and ensure that there are no other people nearby.
- Keep a safe distance from overhead electric lines when raising the tailgate.
- Opening the tailgate and unloading by means of the floor conveyor can only be carried out when the trailer is coupled with the tractor.
- Take special care when unloading using dosing drums, pay attention to the correct operation of the power transmission mechanism.
- If during the operation of the floor conveyor the load does not pour, stop unloading immediately. Reloading is only possible after removing the clogging or failure.
- Take particular care when closing the tailgate as there is a risk of being crushed.
- It is forbidden to operate the floor conveyor mechanism and trailer dosing drums for unloading with the tailgate closed.
- Be especially careful when operating the floor conveyor mechanism due to the danger of being pulled in.
- During winter, pay special attention to loads that may freeze during transport. The frozen load may damage the trailer.
- After unloading, make sure the load box is empty.
- Before unloading the trailer make sure that the PTO shaft rotates in the right direction.
- It is forbidden to drive with the tailgate raised.

2.1.7 TIRES

- When working with tires, the trailer should be immobilized with the parking brake and secured against rolling away by placing chocks under the wheels. The wheel can be dismantled only when the trailer is not loaded.
- Repair work on wheels or tires should be carried out by persons trained and authorized to do so. These works should also be carried out using appropriately selected tools.

- Checking the tightening of the wheel nuts should be carried out after the first use of the trailer, after the first journey with a load and then every 6 months of use. In each case, the inspection activities should be repeated if the trailer wheel was disassembled.
- Avoid damage of road surfaces, sudden and variable maneuvers, and high speeds when turning.
- Regularly check tire pressure. Tire pressure should also be checked during all-day intensive work. It should be taken into account that the increase in tire temperature can increase the pressure by up to 1 bar. With such a rise in temperature and pressure, reduce the load or speed. Never reduce pressure by venting the tire if it increases due to temperature.
- Tire valves should be protected with suitable caps to avoid penetration of dirt.

2.1.8 PRINCIPLES OF SAFE TECHNICAL OPERATION

- During the warranty period, any repairs may only be carried out by a warranty service authorized by the manufacturer. After the warranty period, it is recommended to carry out any repairs to the trailer in a specialized workshop.
- In the event of any failure or damage whatsoever, do not use the trailer until the time of repair.
- During maintenance work, use appropriate, close-fitting protective clothing, gloves and appropriate tools. In the case of work with the hydraulic installation, it is recommended to use oil resistant gloves and protective glasses.
- Any modification to the trailer releases PRONAR Narew from liability for damage or injury.
- Regularly check the technical condition of safety devices and correct tightening of screw connections (in particular drawbar eyes, wheels).
- Carry out the inspections of the trailer according to the frequency specified in this manual.
- Before starting repair work on hydraulic or pneumatic systems, reduce oil or air pressure.

- Perform maintenance and repair activities applying general principles of health and safety at work. In the event of a cut, the wound should be immediately washed and disinfected. If serious injury is suffered, medical advice should be sought.
- Repair, maintenance, cleaning and climbing on the trailer should only be carried out with the tractor engine turned off and the ignition key removed. Tractor and trailer should be secured with parking brake and chocks should be placed under trailer wheels. Secure the tractor cab against unauthorized access.
- If it is necessary to replace individual parts, use only original parts. Failure to comply with these requirements may result in an accident and endanger the health or life of bystanders or persons operating the trailer, cause damage to the machine and constitute the basis for withdrawing the warranty.
- Control the condition of the protective elements, their technical condition and correct mounting.
- Before welding or electrical work, the trailer should be disconnected from the power supply. The paint coating should be cleaned. The fumes of burning paint are poisonous to humans and animals. Welding work should be carried out in a well-lit and ventilated room.
- During welding work pay attention to flammable or fusible elements (elements of pneumatic, electric, hydraulic systems, elements made of plastic). If there is a risk of ignition or damage, they must be removed or covered with non-flammable material before welding. Before starting work, it is recommended to prepare a CO₂ or foam fire extinguisher.
- In the event of work requiring the trailer to be raised, use properly certified hydraulic or mechanical lifts for this purpose. After lifting the machine, stable and durable supports must also be used. It is forbidden to carry out work under a trailer raised only with a jack.
- It is forbidden to support the trailer with fragile elements (bricks, hollow bricks, concrete blocks).
- After completing work associated with lubrication, remove excess grease or oil. The trailer should be kept clean.

- Be careful when entering the load box. Climbing is possible after raising the tailgate and using a ladder. Before entering the load box, secure the trailer by immobilizing it with the parking brake and using chocks. It is forbidden to enter the load box with the feeding mechanism or power transmission mechanism switched on.
- It is forbidden to carry out independent repairs of the control valve, brake cylinders and braking force regulator. In case of damage to these elements, the repair should be entrusted to authorized repair centers or the elements replaced with new ones.
- It is forbidden to repair the drawbar eye (straightening, surfacing, welding). Damaged towing eye should be replaced.

2.2 RESIDUAL RISK

The company Pronar Sp. z o. o. in Narew made every effort to eliminate the risk of an accident. However, there is some residual risk that can lead to an accident and is primarily associated with the following activities:

- using the trailer contrary to its purpose,
- staying between the tractor and the trailer during engine operation and when connecting the machine,
- presence on the machine while the engine is running,
- trailer operation with removed or defective covers,
- failure to maintain a safe distance when loading or unloading the trailer,
- trailer operation by unauthorized persons or people under the influence of alcohol,
- presence of blind spots in the field of view,
- cleaning, maintenance and technical inspection of the trailer.

Residual risk can be reduced to a minimum by following these recommendations:



- reasonable and “not under rush” machine operation,
- reasonable application of the remarks and recommendations contained in the operating instructions,



- maintaining a safe distance from prohibited or dangerous places during unloading, loading and coupling the trailer,
- performing maintenance and repair work in accordance with the principles of operating safety,
- carrying out maintenance and repair work by trained persons,
- use of appropriate protective clothing,
- securing the machine against access by unauthorized persons, especially children,
- maintaining a safe distance from prohibited and dangerous areas,
- prohibition of being on the machine while it is operating.

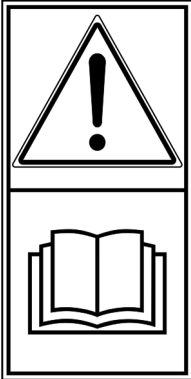
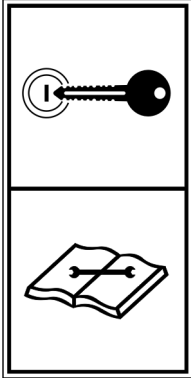
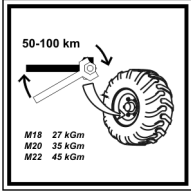

2.3 INFORMATION AND WARNING STICKERS



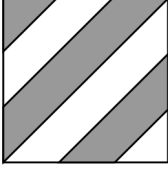
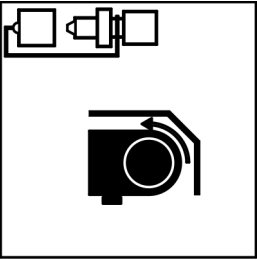
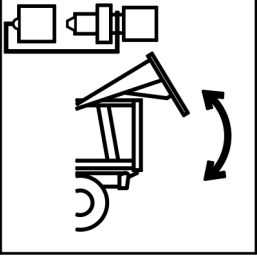
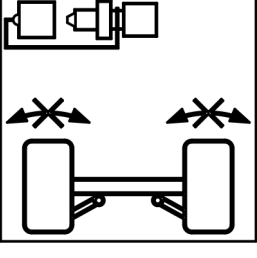

The trailer is marked with information and warning decals mentioned in table (2.1). Arrangement of symbols is shown in Figure (2.3). The machine user is obliged to ensure that the inscriptions, warning and information symbols placed on the trailer are readable throughout the entire period of use. In the event of their destruction, they must be replaced. Labels with inscriptions and symbols are available from the Manufacturer or in the place where the machine was purchased. New assemblies replaced during repair must be marked again with the appropriate safety signs. When cleaning the trailer, do not use solvents that may damage the label coating. When washing the machine with a pressure washer, do not aim the water jet directly at the labels.

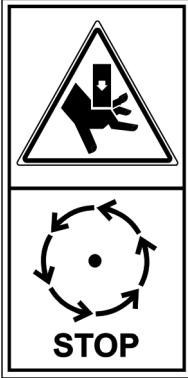
Table 2.1 Information and warning decals

LP.	DECAL	DESCRIPTION
1		Trailer type.
2		<p>Attention!</p> <p>Before starting work, read the User manual.</p>
3		<p>Before starting service or repair work, turn off the shredder motor and remove the ignition key</p>
4		Control the condition of screw connections of axles
5		Lubricate the shredder according to the schedule included in the User manual.

LP.	DECAL	DESCRIPTION
6		Warning decal.
7		Turning on / of the conveyor mechanism – red connector cap.
		Raising / lowering the tailgate – black connector cap.
		Turning on / of the steering blocking mechanism – blue connector cap.
8		Minimum permissible vertical load on the tractor hitch.
9		<p>Danger of crushing the entire body.</p> <p>Keep a safe distance from the tailgate.</p>

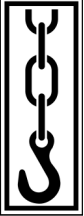
LP.	DECAL	DESCRIPTION
10		<p>Before entering the loading surface, switch off the tractor engine and remove the ignition key.</p>
11		<p>Danger of limbs crushing. Exercise caution near rotating machine components.</p>
12		<p>Danger of crushing. Keep your limbs away from the danger zone.</p>
13		<p>Attention! Do not stand on conveyors.</p>

LP.	DECAL	DESCRIPTION
14		<p>Danger of crushing. Keep your limbs away from the danger zone.</p> <p>Exercise caution near rotating machine components.</p>
15		Information label.
16		Air pressure in the tires.
17		Mounting points for transport.
18		Drive shaft rotational speed.

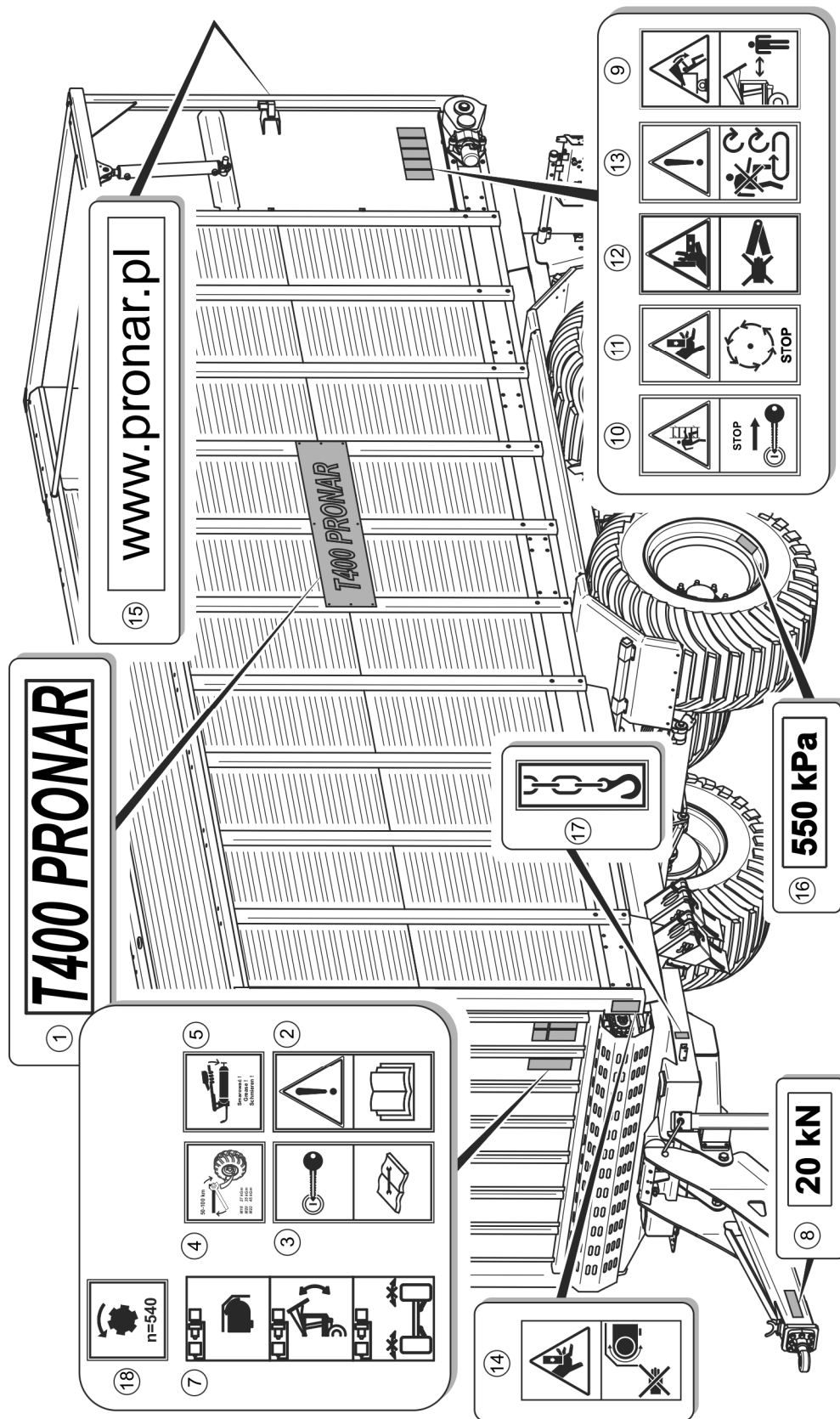

Figure 2.3 Information and warning decals positioning

CHAPTER

3

**STRUCTURE AND
PRINCIPLES OF
OPERATION**

3.1 TECHNICAL FEATURES

Table 3.1 Technical features for standard version

DESCRIPTION	UNIT	T400
Dimensions		
Overall length (with drawbar)	mm	10 100
Overall width	mm	2 900
Maximum height	mm	3 950
Wheel track	mm	2 200
Wheelbase	mm	1 810
Inner load box dimensions:		
- length	mm	8 000
- width		
- front	mm	2 080
- rear	mm	2 130
- height	mm	2 260
Operational parameters		
Loading capacity	m ³	40
Loading area	m ²	16.84
Maximum laden mass	kg	22 000
Maximum technically permissible load	kg	14 550
Own weight	kg	7 450
Minimum tractor power	kW / KM	118 / 160
Hydraulic system		
Maximum working pressure	bar / MPa	20
Oil demand	l	10
Hydraulic oil type	-	LHL32 Lotos
Other		
Design speed	km/h	40
Maximum hitch load	kg	2 000
PTO speed	rpm	540
PTO rotation direction	-	Clockwise

3.2 CHASSIS

The chassis of the trailer is shown in figure (3.1). The lower frame (1) is made as a welded structure of steel sections. The main supporting element are two longitudinal longerons made of closed profiles. Longerons are connected to each other by C-shape profiles acting as crossbars, on which the load box is mounted - figure (3.2). Brackets fixing trailer suspension are welded to both longitudinal longerons.

In the chassis, axle load balancing is achieved by the swingarms located between the absorber springs (5). They are hung on brackets with maintenance-free metal-rubber sleeves. Each axle is equipped with an adjustment screw (turnbuckle) on one side, and a rigid tie on the other. This makes it possible to adjust the axle between themselves and relative to the longitudinal axis of the vehicle (tracing adjustment). On a new trailer, the suspension is factory-set. Axle (3) is a trailing steering axle, while axle (2) is a rigid axle. Trailer axles are made of square profile capped with pins, on which road wheel hubs are mounted. The trailer is equipped with four single wheels (4) equipped with drum brakes activated by mechanical cam shaft. Each pair of wheels is protected by a metal mudguard (7) mounted on brackets bolted to the trailer frame.

In the rear part of the trailer there is a bumper attached to the chassis with bolts (8). Above the bumper there is a crossbar to which the rear coupling for connecting the second trailer is attached with screws, an additional rear coupling is included in the optional equipment. On both sides of the longerons in the front and rear of the trailer, rear lighting panels (9) and front supports (13) are mounted, on which the trailer's front position lights are located. Rear group lamps and end-outline lamps are mounted on the rear lighting panels.

In the front part of the chassis, there is a drawbar with shock absorber (6), next to the drawbar on the right side of the trailer there is a support screwed to the construction (11).

In standard equipment of the Pronar T400 trailer, there are also two support chocks (10) mounted on the left longeron. On the opposite side of the trailer there is a tool box (12).

In the optional equipment of the trailer, it is possible to mount the power transmission mechanism of the dosing drums located in the load box. Details of both installations are given in chapter (3.9) *DOSING DRUMS WITH POWER TRANSMISSION SYSTEM*.

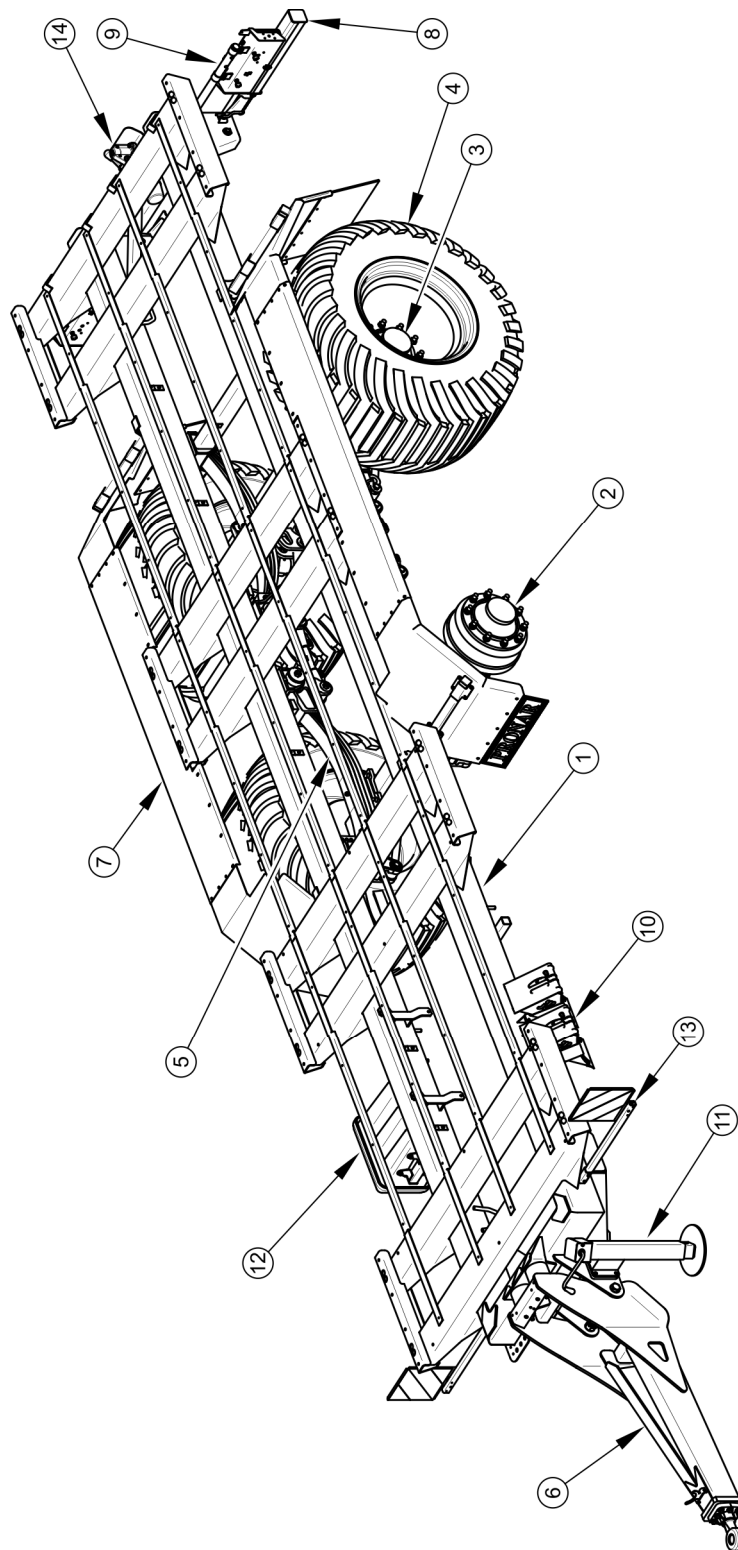

Figure 3.1 Components of the chassis

(1) lower frame, (2) rigid front axle, (3) rear steered axle, (4) wheel, (5) absorber spring, (6) drawbar, (7) mudguard, (8) bumper, (9) lightning panel, (10) chock, (11) support, (12) tool box, (13) front support, (14) rear coupling

3.3 LOADING PLATFORM

The load box consists of welded elements that are connected with each other by bolts. The front wall of the trailer is made as a welded structure made of steel profiles and sections. In its upper part there is an openable tilting extension (3). It is used to load materials using a combine harvester or forage harvester by reducing the height of the front wall.

The side walls are made of two longitudinal beams to which the side posts are bolted. This construction is in whole covered with perforated steel sheet riveted to the bearing elements. Both side walls are connected with each other by screwed crossbars on the bottom, while at the top with two tightening strings (7).

Floor conveyor track guides (4) are bolted to the crossbars of the lower side walls. The mechanism is driven by hydraulic motors and is intended for unloading. The gear chains slide in the guide troughs, the scraper bars (5) are attached to the chains. A detailed description of the installation can be found in chapter 3.5 FLOOR CONVEYOR MECHANISM HYDRAULIC SYSTEM.

The floor (6) of the Pronar T400 trailer is made of boards laid and bolted to the lower crossbars of the load box. The boards are arranged tightly next to each other, each subsequent board is shifted towards the neighbor by half the length. The side surfaces of the boards are connected by means of a tongue and a groove.

The rear part of the loading box has a hinged tailgate. It is made as a welded structure made of profiled sheet and steel profiles. The tailgate is raised by means of two hydraulic cylinders located on both sides of the box. A detailed description of the hydraulic installations can be found in chapter - 3.4 TAILGATE HYDRAULIC SYSTEM.

In the rear part of the load box it is possible to install dosing drums to facilitate precise unloading of the trailer. The drums come in two variants, drums for green fodder and drums for corn chaff. The structure and operation of this mechanism is described in chapter (3.9) DOSING DRUMS WITH POWER TRANSMISSION SYSTEM.

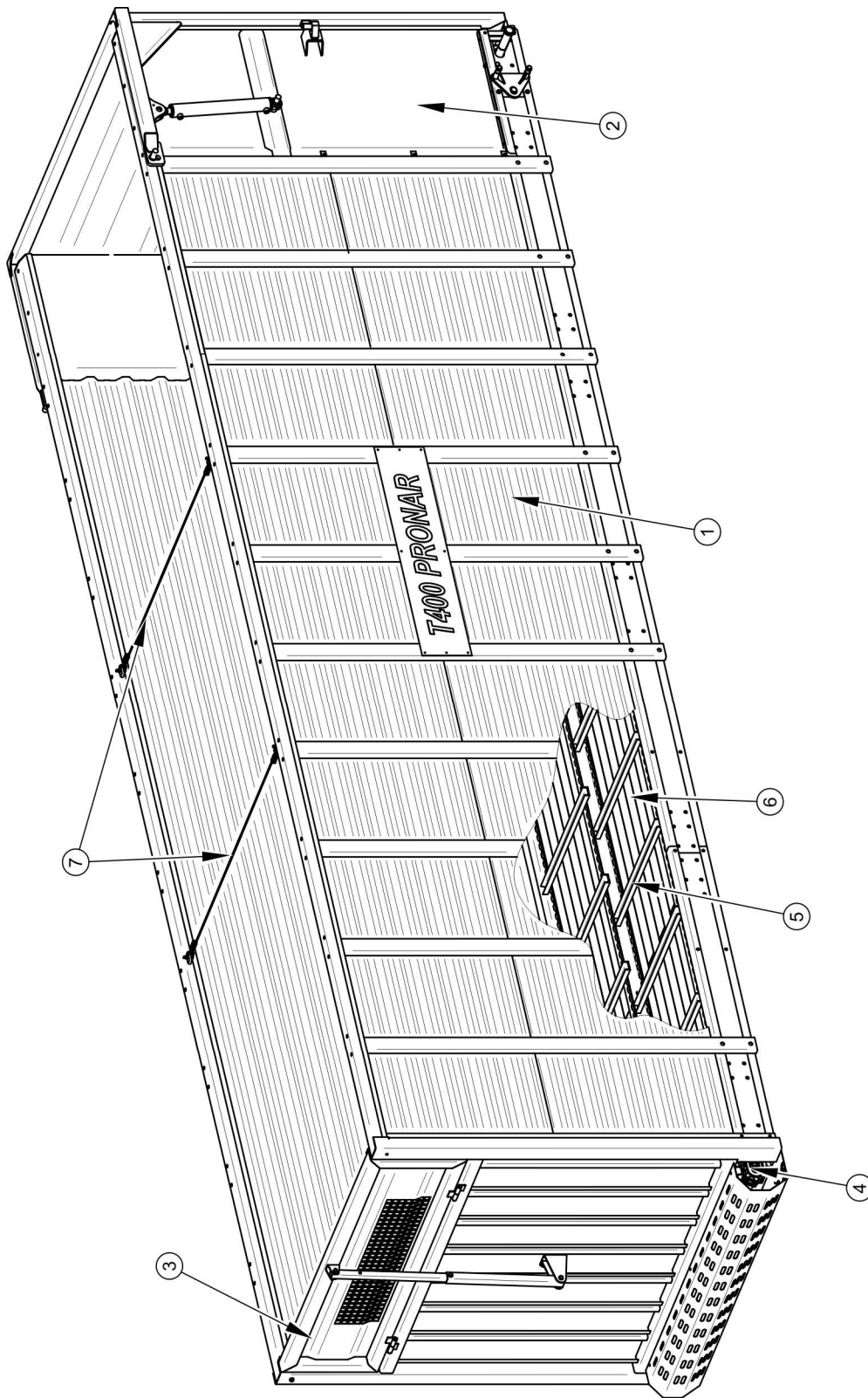

Figure 3.2 Load box components

(1) side wall, (2) tailgate, (3) tilting extension, (4) floor conveyor, (5) scrapper bar, (6) floor, (7) tightening string

3.4 TAILGATE HYDRAULIC SYSTEM

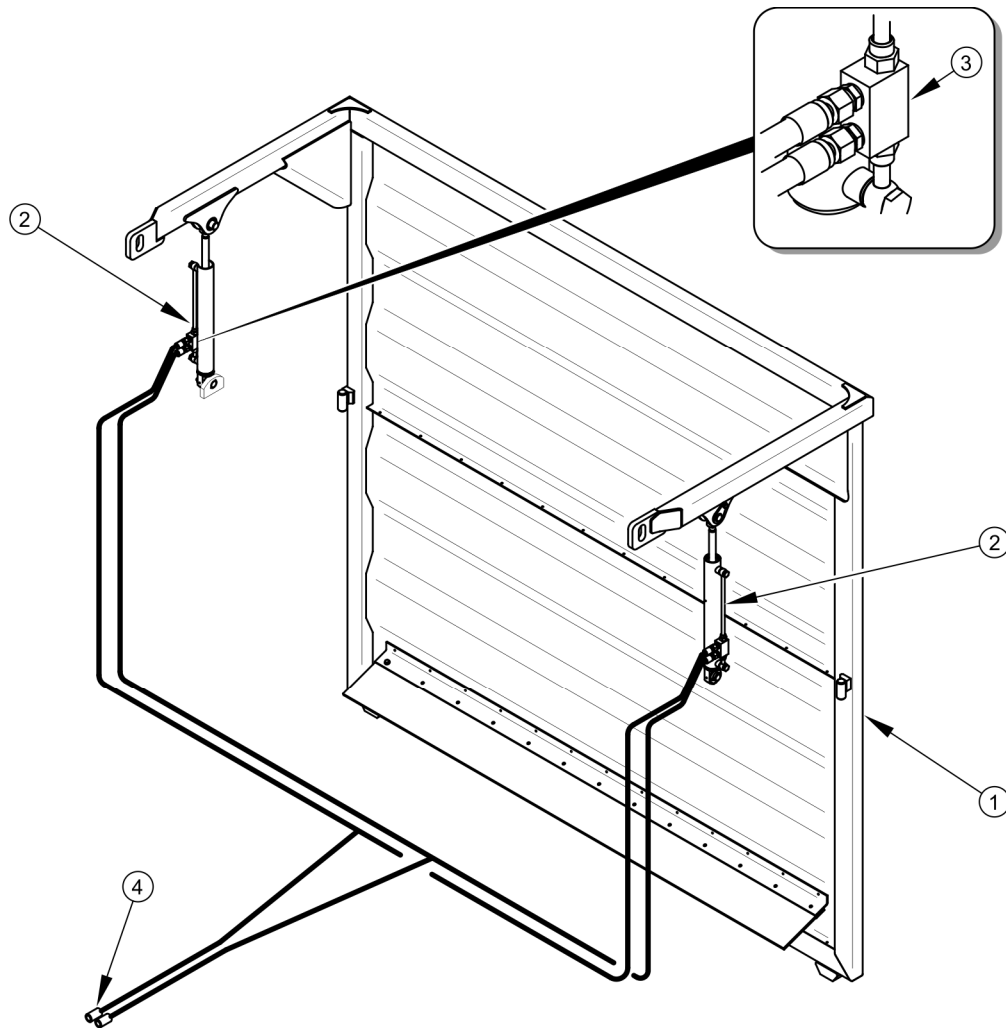

Figure 3.3 Tailgate hydraulic system

(1) tailgate, (2) hydraulic cylinder, (3) hydraulic lock, (4) hose



TIP

Protective caps for quick connectors of the tailgate hydraulic systems are marked in blue - see TABLE (2.1).

The rear part of the trailer has a hinged tailgate (1). The tailgate is raised and lowered using the hydraulic system shown in figure (3.3). The system is supplied with oil from the tractor's external hydraulics. Oil under pressure through plugs (4) and then hydraulic lines goes to hydraulic cylinders (2). Double-acting cylinders, which are used to open or close the damper

are equipped with hydraulic locks (3), which are designed to block the tailgate in the raised position. The use of hydraulic locks increases the safety of trailer use.

Hydraulic locks (3) are designed to lock the tailgate in a fixed, unchanged position in the event of the system unsealing.

The tailgate is controlled from the tractor cabin through the lever of the tractor's external hydraulic distributor.

Diagram of the tailgate hydraulic system is presented in the figure (3.4).

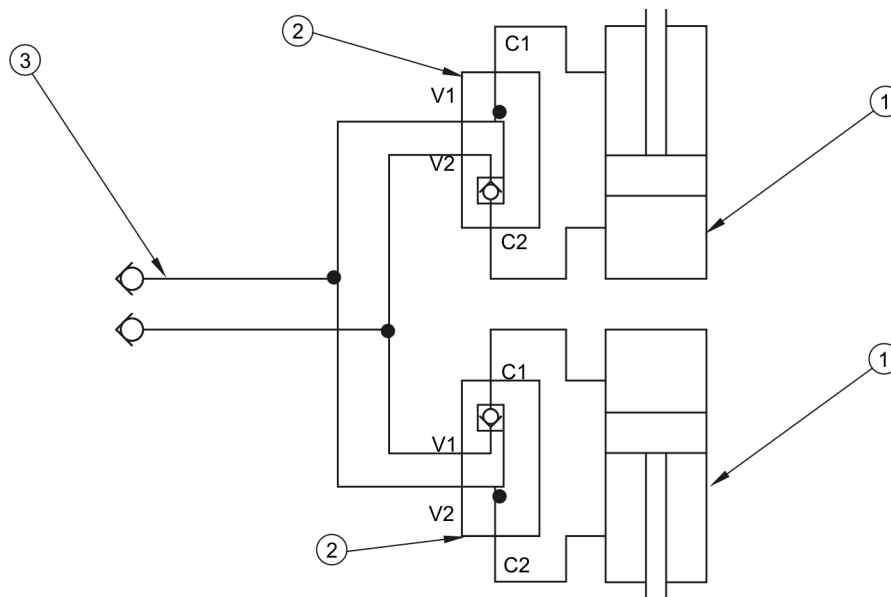

Figure 3.4 Diagram of the tailgate hydraulic system

(1) hydraulic cylinder, (2) hydraulic lock, (3) hose

3.5 FLOOR CONVEYOR MECHANISM HYDRAULIC SYSTEM

The Pronar T400 trailer is equipped with a floor conveyor mechanism hydraulic system - figure (3.5), designed for automatic unloading of volumetric materials by moving the scraper bars backwards with the help of chains. This solution ensures unloading of transported materials in silos or on piles without the need to tip the load box.

The conveyors hydraulic system is supplied with oil from the external hydraulic system of the agricultural tractor. Hydraulic oil from the quick couplers (5) goes to the stream divider (4), which is designed to split the oil stream for two hydraulic motors (1). The motors drive the reducers (2), which are coupled to the shafts of the conveyor mechanism. Both conveyors

move at similar speeds and their scraping bars are arranged alternately for easier unloading. The installation has two valves (3) to protect hydraulic motors from damage.

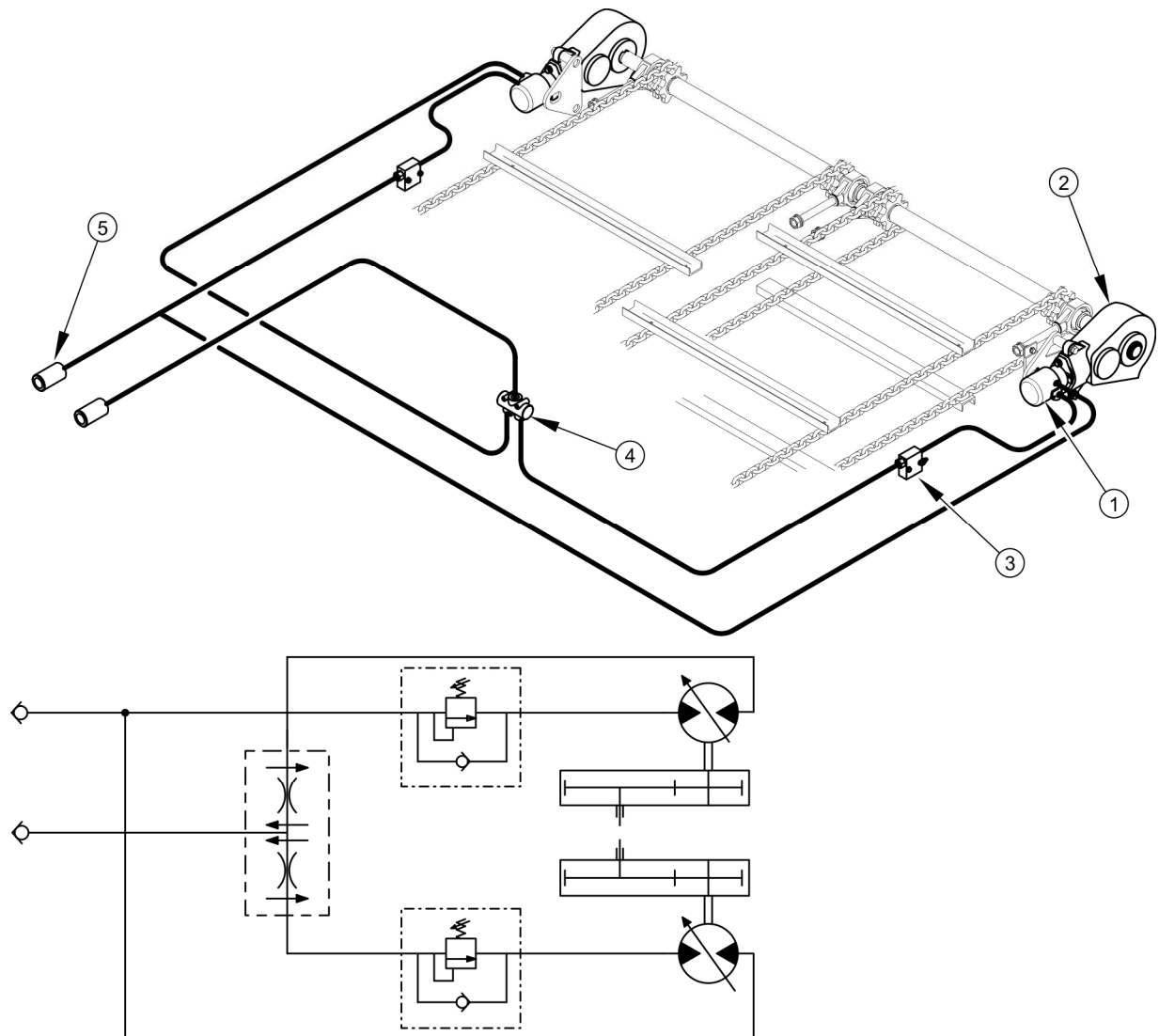

Figure 3.5 Schematic diagram and design of the floor conveyor mechanism hydraulic system

(1) hydraulic motor, (2) reducer, (3) valve, (4) stream divider, (5) quick coupler



TIP

Protective caps of floor conveyor mechanism hydraulic system quick couplings are marked in red - see TABLE (2.1).

3.6 STEERING AXLE HYDRAULIC SYSTEM

The Pronar T400 trailer is, as a standard, equipped with a rear steering axle, passively steered - figure (3.6). The axle design enables easy and undisturbed cornering especially on marshy terrain, which reduces machine tire wear.

When driving backwards, the axle reaction rods must be blocked, otherwise the trailer will tend to turn uncontrollably to the left or right when reversing.

The axle can be locked by a single-line hydraulic system as shown in figure (3.6). before driving backwards, extend the steering cylinders with the tractor distributor lever.

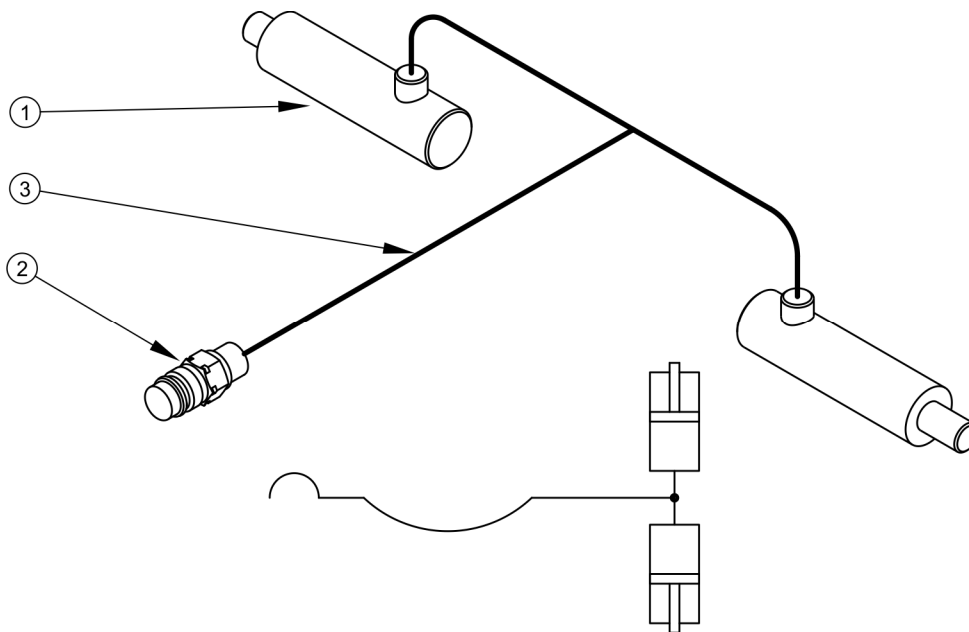

Figure 3.6 Design and schematic diagram of the steering lock hydraulic system

(1) axle lock cylinder, (2) quick coupling - plug, (3) hydraulic hose



TIP

The protective cap of the steering lock hydraulic quick coupling is marked in blue - see TABLE (2.1).

3.7 TILTING FRONT WALL HYDRAULIC SYSTEM

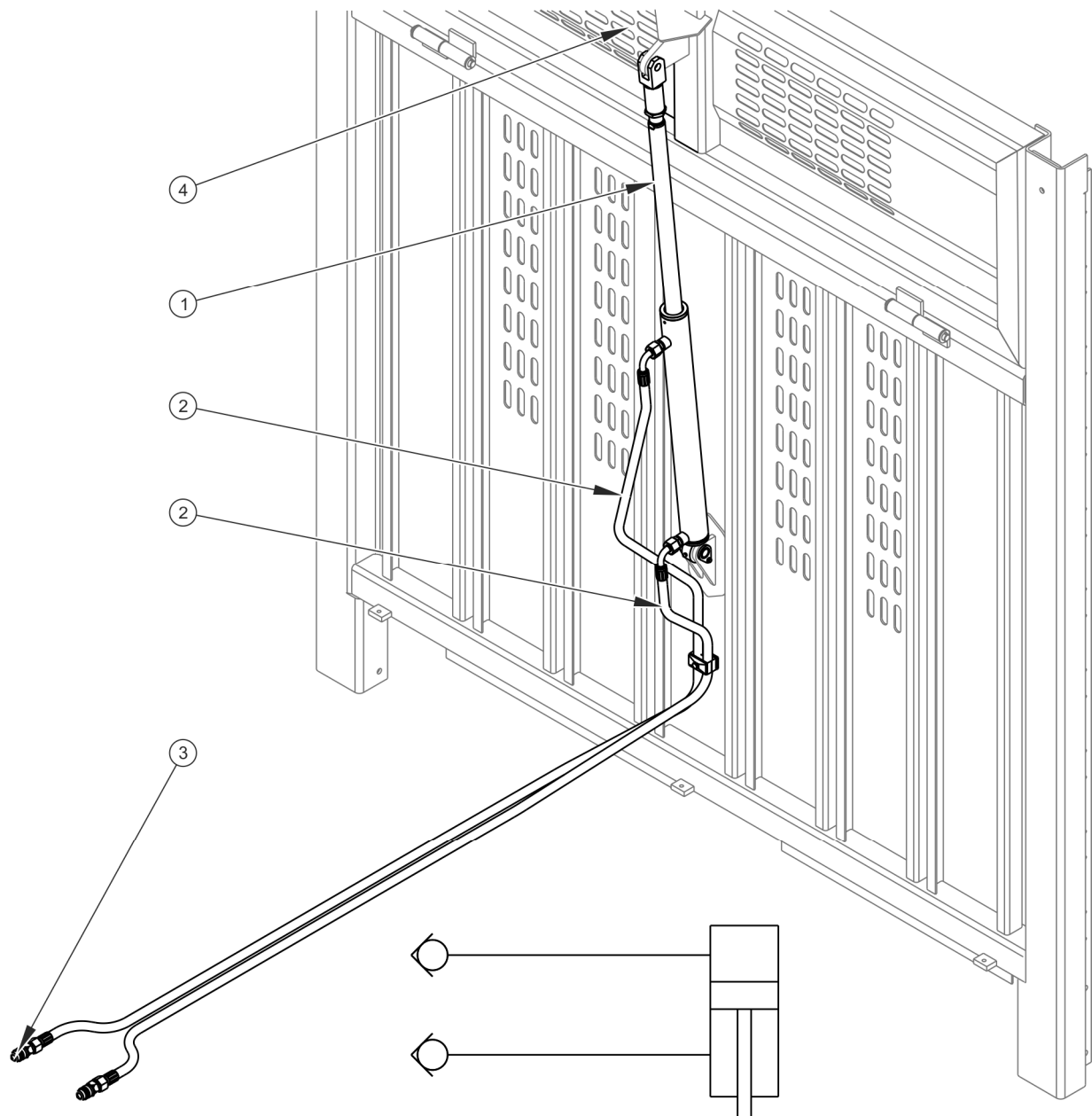

Figure 3.7 Front tilting extension hydraulic system

(1) cylinder, (2) hydraulic hose, (3) quick coupling - plug, (4) front extension

The tilting front extension (2) makes loading the trailer with the help of self-propelled forage harvesters, belt conveyors or self-propelled loaders easier.

Opening and closing the extension is carried out by means of a hydraulic cylinder (1), which is supplied with hydraulic oil from the external hydraulic system of the agricultural tractor.

Hydraulic oil from quick couplers (3) goes through hoses (2) to the cylinder (1) which, depending on the direction of oil supply, opens or closes the trailer's front extension.

3.8 PNEUMATIC BRAKES SYSTEM

The T400 trailer is equipped with one of two types of service brake systems (pneumatic brakes):

- Two-line pneumatic system with manual braking force regulator - figure (3.8) - standard equipment,
- Two-line pneumatic system with automatic braking force regulator - figure (3.9) - optional equipment.

The service brake is activated from the tractor driver's workplace by pressing the tractor brake pedal. The control valve activates the trailer's brakes simultaneously when the tractor's brake is applied. In addition, in the event of an unforeseen disconnection of the conduit between the trailer and the tractor, the control valve (2) automatically actuates the trailer brake. The valves used have a brake release system, used when the trailer is disconnected from the tractor.

After connecting the air line to the tractor, the release device automatically adjusts to the position enabling normal brake operation.

The brake cylinders (6) used in the installations are mounted on specially prepared brackets welded to the driving axles. They are membrane actuators. The air supplied to the cylinder exerts pressure on the diaphragm, which in turn moves the cylinder piston rod and rotates the axle expander lever. The return of the actuator to the neutral position is supported by the extraction springs.

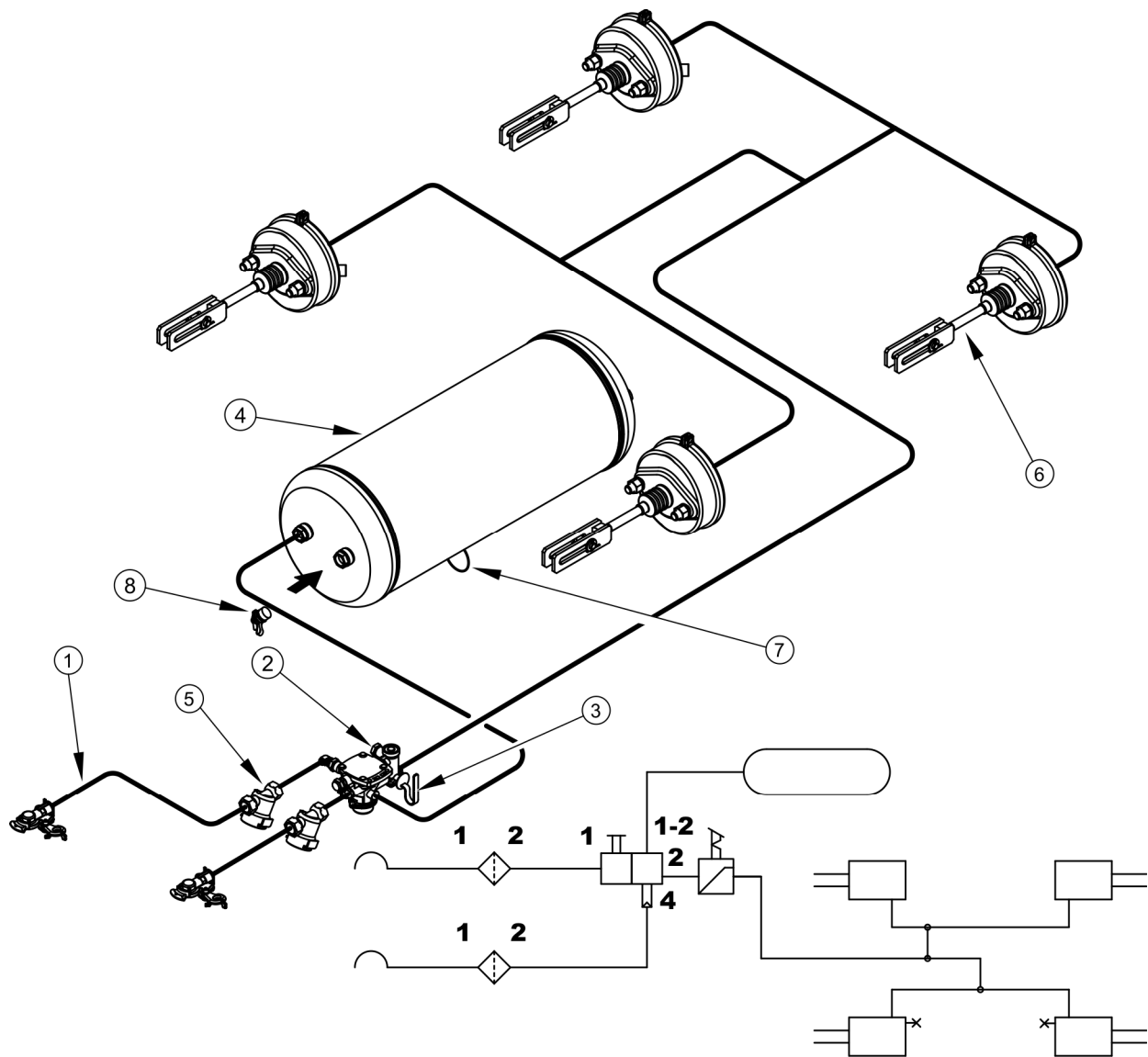

Figure 3.8 Design and schematic sketch of the brake installation with manual braking force regulator

(1) line connector, (2) control valve, (3) braking force regulator, (4) air tank (5) air filter, (6) pneumatic cylinder, (7) drain valve, (8) control connector

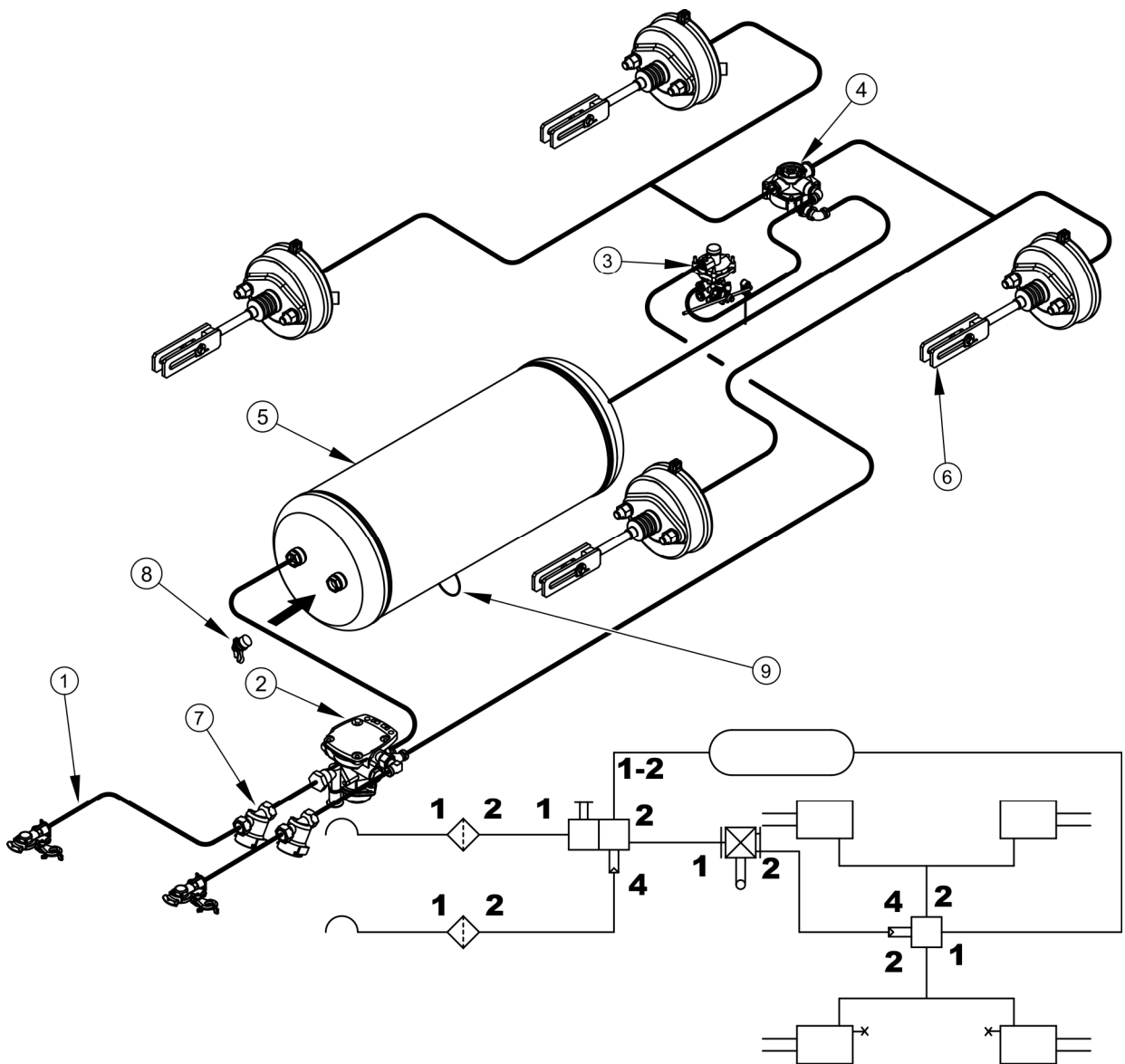

Figure 3.9 Design and schematic sketch of the brake installation with automatic braking force regulator

(1)) line connector, (2) control valve, (3) automatic brake force regulator, (4) relay valve, (5) air tank, (6) pneumatic cylinder, (7) air filter, (8) air tank control connector, (9) drain valve

The automatic braking force regulator (3) adjusts the braking pressure depending on the load of the trailer. During normal operation it requires no maintenance.

Each pneumatic connection is equipped with a shut-off valve, which automatically cuts off the outflow of air from the pneumatic conduit in case of disconnection from the agricultural tractor socket.

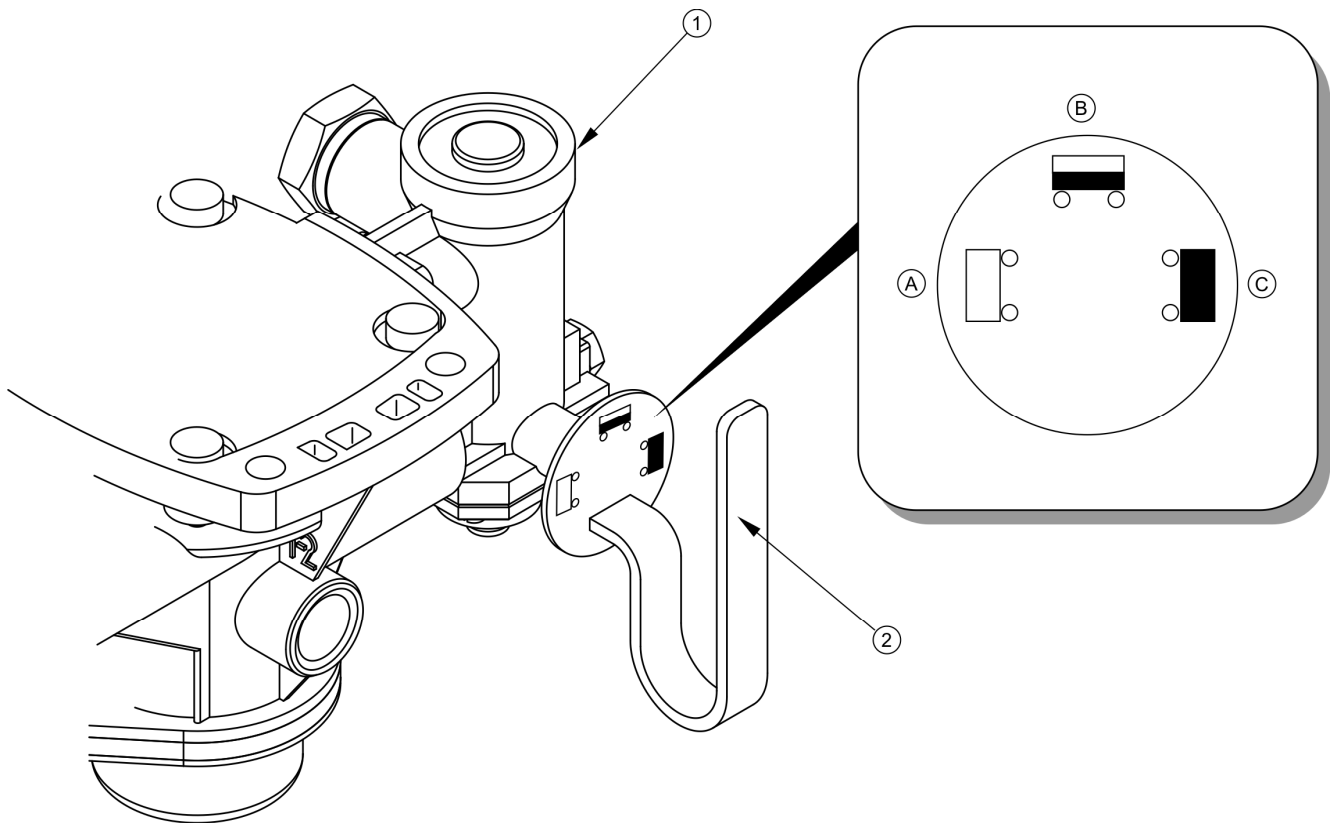

Figure 3.10 Three-position manual regulator

(1) three-position braking force regulator, (2) regulator setup selection valve, (A), (B), (C) regulator setup positions

TIP



The system is equipped with two pneumatic connections. They are marked with colored protective covers, which enables identification of individual connections:

- red – supply line,
- yellow – control line.

Three-position braking force regulator - figure (3.10), used in pneumatic installations, adjusts the braking force depending on the setting. Switching to the appropriate operating mode is carried out manually by the machine operator using the lever (2) before starting to drive. Three working positions are available: A - "No load", B - "Half load" and C - "Full load".

3.9 DOSING DRUMS WITH POWER TRANSMISSION SYSTEM

The dosing drums are driven by means of a power transmission mechanism consisting of shafts, PTO couplings and an angular gear (3). The construction of the transmission mechanism and dosing drums is shown in Figure (3.11).

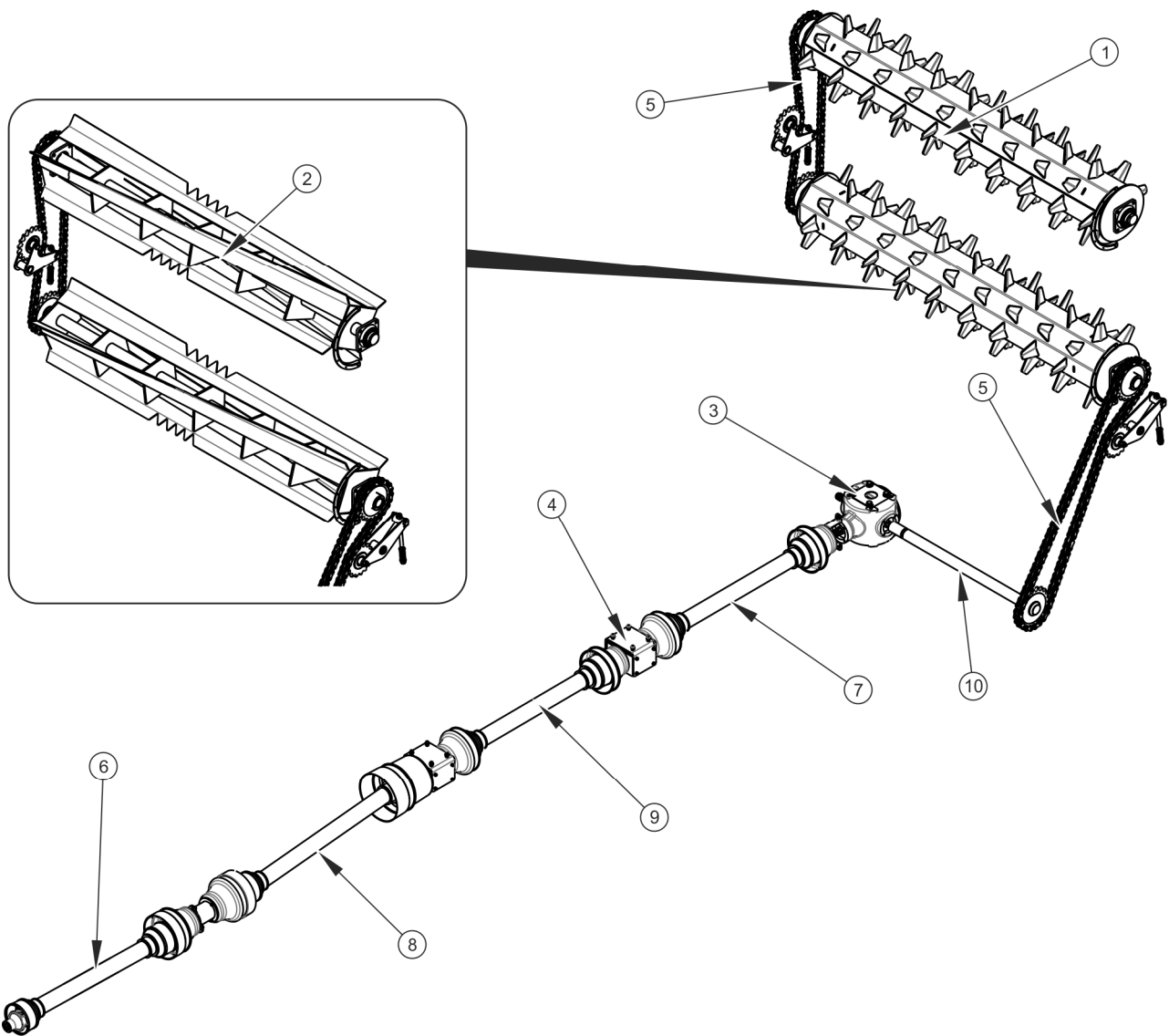

Figure 3.11 Dosing drums

(1) green fodder dosing drums, (2) corn chaff dosing drums, (3) angular gear, (4) PTO connector, (5) chain, (6) tractor drive shaft, (7) drive shaft, (8) drive shaft with automatic clutch, (9) drive shaft, (10) drum drive shaft

On the front wall of the lower frame of the trailer there is a PTO connector with a spline end, to which the PTO shaft (6) on the tractor side and the PTO shaft (8) with an automatic clutch

on the trailer side are connected. The shaft (6) is equipped with an automatic clutch that protects the power transmission mechanism to the dosing drums. The clutch interrupts power transmission when the torque exceeds the clutch calibration value. After decreasing the shaft speed or stopping power take-off, the clutch automatically re-engages.

Torque is transmitted from the tractor through PTO shafts (6), (7), (8) and (9) to the gearbox (3). From the gearbox via the drum drive shaft (10), the drive is transmitted to the lower drum chain transmission and from there another chain transmission to the upper dosing drum. Both chain transmissions are equipped with tensioners.

Figure (3.11) presents dosing drums facilitating precise unloading of cargo from the trailer's load box. The drums were placed in the rear part of the loading box and mounted on rolling bearings. The drums are driven by means of a power transmission mechanism. Two types of dosing drums are available, drums dedicated to the green fodder (1) and corn chaff drums (2).

**TIP**

PTO shaft revolutions speed is equal to 540 rpm. It is not allowed to use other PTO shaft revolutions during service of dosing drums.

3.10 PARKING BRAKE

The parking brake is used to immobilize the trailer during parking. The brake crank mechanism (1) is attached to the left longeron of the lower frame. A steel string (4) connects the expander levers (2) of the front axle with the crank mechanism. Tensioning the cable causes movement of the expander levers, which in turn spreads the brake shoes immobilizing the trailer during parking.

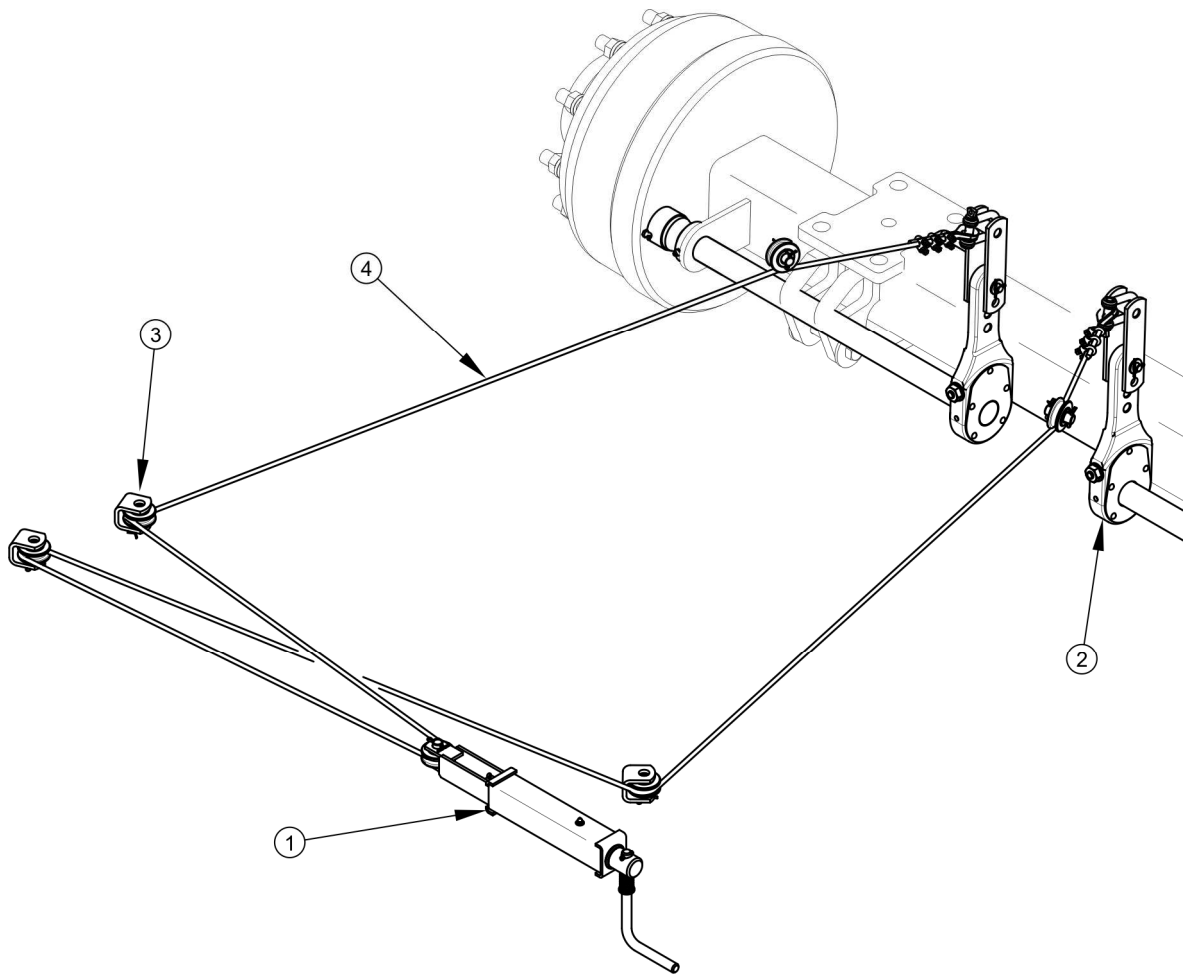

Figure 3.12 Parking brake

(1) brake crank mechanism, (2) expander arm, (3) guide wheel with mounting, (4) string

3.11 WHEELS STEERING LOCK SYSTEM

The trailer is equipped, as a standard, with a rear steering axle, passively steered. The axle design allows for smoother cornering and easier maneuvering on marshy terrain, which reduces machine tire wear. When reversing, the axle hubs must be locked, otherwise the trailer will tend to turn uncontrollably to the left or right.

The axle can be locked by a single-line hydraulic system as shown in Figure (3.13). Before driving backwards, extend the hydraulic steering lock cylinders (1) using the tractor distributor lever.

The hydraulic connector of the turning lock system is marked with blue caps, as indicated on the sticker (5).

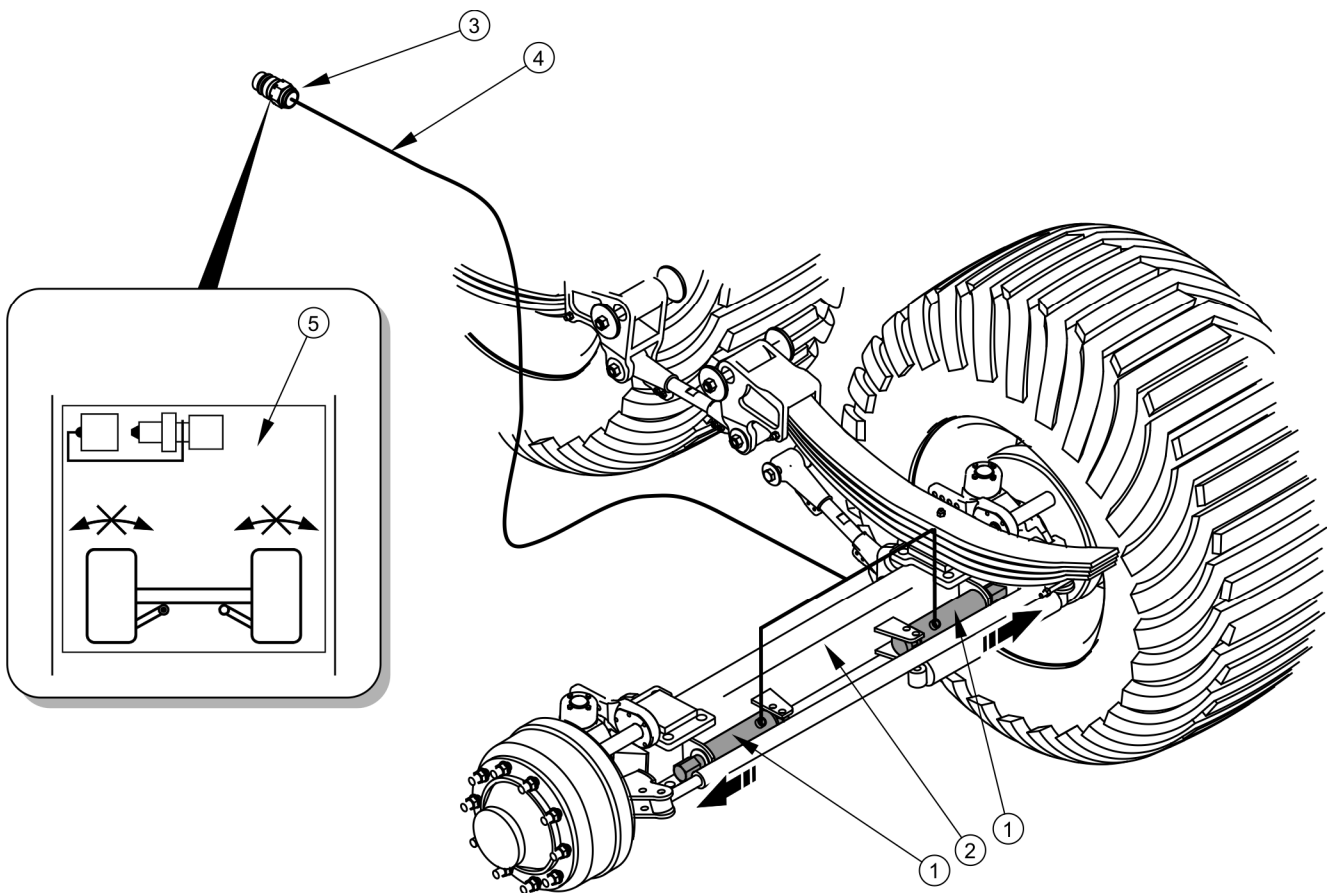

Figure 3.13 Steering system components

(1) steering lock cylinder, (2) rear steering axle, (3) hydraulic quick coupling, (4) hydraulic hose, (5) information label

3.12 LUBRICATION SYSTEM

The trailer is equipped with a lubrication system facilitating lubrication of the floor conveyor chain drive mechanisms. The construction of the loading box enables the installation of a lubrication system on the right or left side of the trailer. The grease nipple body (4) is screwed to the load frame beam. Grease nipples (1) are screwed into the body (4) and are connected to the grease lines (3). The wires run to the angled terminals screwed into the shafts of the drive mechanism.

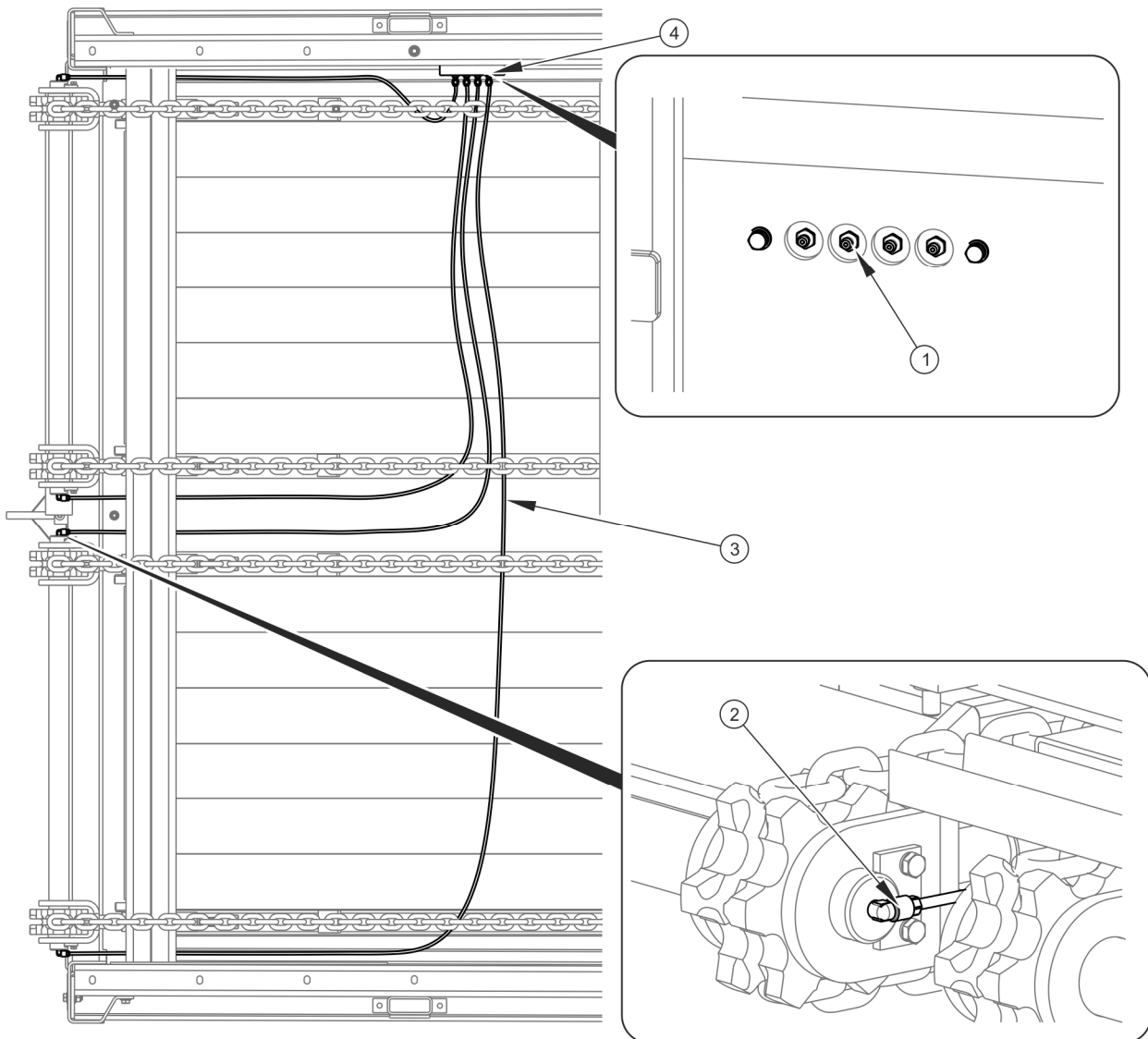

Figure 3.14 Lubrication system components

(1) straight connector with a cap, (2) angled connector, (3) grease line, (4) grease nipple body



TIP

A detailed schedule of trailer lubrication is given in chapter 5 TRAILER LUBRICATION.

3.13 ELECTRICAL AND LIGHTNING SYSTEM

The lightning electrical installation of the trailer is adapted to be powered from a 12 V DC source. Two cables with 7-pin plugs, compliant with ISO 1724 standards are intended for powering the system.

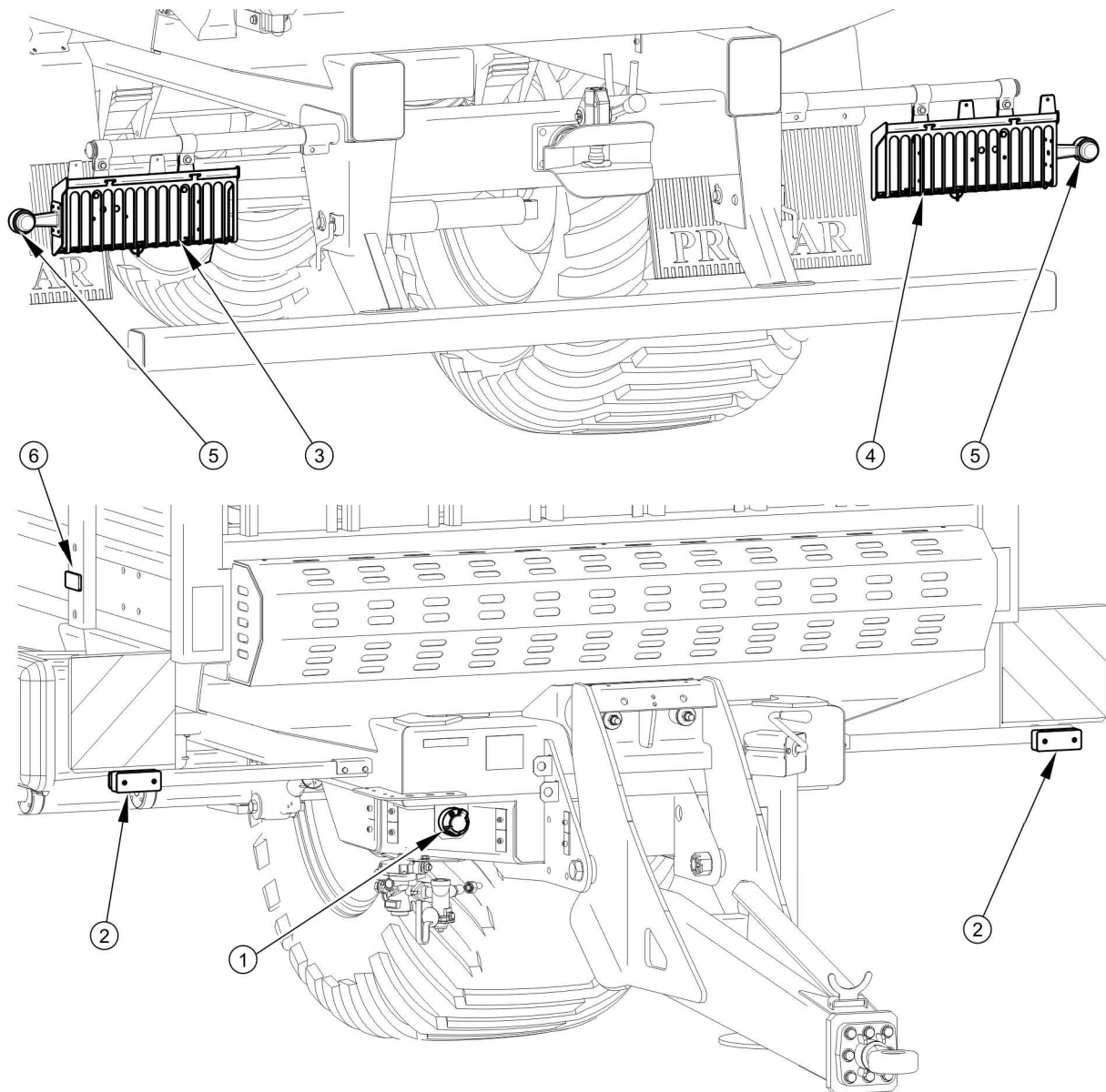

Figure 3.15 Lightning system components

(1) 7-pin plug, (2) front position lamp, (3) rear left grouped lamp, (4) rear right grouped lamp, (5) end-outline lamp, (6) side retro-reflector (orange)

Table 3.2 Pin Connectors compliant with ISO 1724

PIN	DIN MARKING	COLOR	FUNCTION
1	31	BLACK	Ground
2	58L	ORANGE	Left position lights
3	L	BLUE	Left direction-indicator
4	54	GREEN	STOP lights
5	R	BLACK – GREEN	Right direction-indicator
6	58R	BROWN	Right position lights

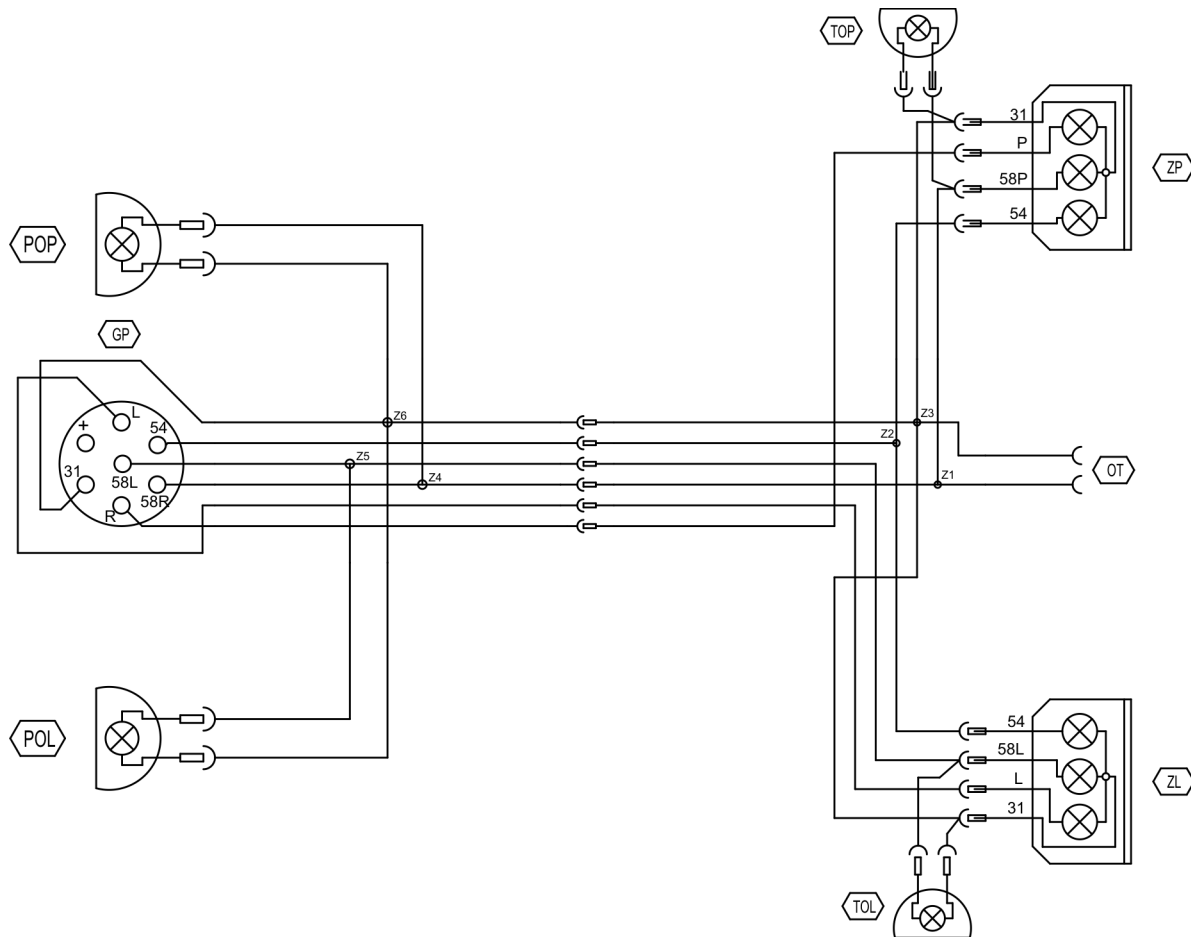

Figure 3.16 Lighting electrical installation sketch

(1) socket, (2) front position lamp (white), (3) side retro-reflector (amber), (4) rear grouped lamp, (5) registration plate lamp

CHAPTER

4

PRINCIPLES OF USE

4.1 PREPARATIONS BEFORE FIRST START-UP

The manufacturer ensures that the Pronar T400 trailer is fully functional, it has been checked in accordance with control procedures and approved for use. However, this does not release the user from the obligation to check the machine after delivery and before first use. The machine is delivered to the user completely assembled. Before connecting to the tractor, the machine operator must check the technical condition of the trailer, prepare it for the first start-up and adjust it as needed. The operator shall:

- get acquainted with the content of this manual and follow its recommendations, learn the structure and understand the principles of machine operation,
- check the condition of the paint coating,
- inspect individual trailer elements for mechanical damage resulting from, among others, due to incorrect transport of the machine (dents, punctures, bends or broken parts),
- check all trailer lubrication points, if necessary, lubricate the machine in accordance with the recommendations contained in chapter 5,
- check the condition of the road wheel tires and the air pressure in the tires,
- check technical condition of pneumatic lines,
- drain the air tank in the braking system,
- check the tightness of nuts securing road wheels, drawbar, side walls and other bolted connections,
- check that nobody or anything is in the load box.
- make sure that the coupling, pneumatic and electrical connections on the tractor comply with the requirements, otherwise do not connect the trailer.
- check the completeness and technical condition of the additional equipment,

If all the above-mentioned activities have been carried out and the technical condition of the trailer does not raise any objections, connect it to the tractor. Start the tractor, check individual systems and carry out a test run of the trailer without load. It is recommended for the visual inspection to be carried out by two persons, one of them should be permanently in

the tractor's cab. In order to carry out an inspection, the following actions should be performed:

- after coupling the trailer, raise the drawbar support,
- check if lighting system is functional by activating individual trailer lights,
- driving forward check the operation of the service brake,
- check the tightness of individual hydraulic installations,
- make sure that the pneumatic system is tight,

ATTENTION



It is forbidden to use the trailer for purposes other than those for which it was intended.
Before each use of the trailer always check its technical condition. In particular, check the technical condition of the hitch system, driving system, the braking system and traffic lights. Check the completeness of the safety guards.

DANGER



Before using the trailer, the user should carefully read the content of these instructions.
Careless and improper use and operation of the trailer, as well as non-compliance with the recommendations contained in these instructions creates a threat to health.
The trailer must not be used by persons who are not authorized to drive agricultural tractors, including children and people under the influence of alcohol or other drugs.
Non-compliance with the rules of safe use poses a threat to the health of operators and bystanders.
When starting the hydraulic motor, keep a safe distance from danger zones.

In the event of a malfunction, locate the fault. If it cannot be removed or its removal could invalidate the warranty, please contact your dealer to clarify the problem.

4.2 TECHNICAL CONDITION CONTROL

Table 4.1 TECHNICAL CONTROL SCHEDULE

DESCRIPTION	MAINTENANCE ACTIONS	INSPECTION INTERVAL
Operation of the braking system	Hitch the trailer to the tractor, driving forward check the operation of the brakes	Daily inspection
Functionality of lighting and signaling system	After connecting the trailer to the tractor, turn on the individual lights one by one, check the completeness of the reflectors, correct placement of the slow-moving vehicle warning sign.	
Hydraulic system operation	Check tightness and quality of hydraulic system functioning during operation.	
Condition of road tires and air pressure in the tires	Carry out a visual inspection of the technical condition of tires and the inflation level.	
Condition of road tires and air pressure in the tires	Check technical condition of tires (tread, side surfaces, condition of disc wheel), check tire pressure.	According to chapter (5.2.5)
Tightening torque of the most important screw connections	The tightening torque should be the same as presented in table (5.7)	Every 6 months
Lubrication	Lubricate the components according to the guidelines in the "Lubrication" chapter.	According to the table (5.4)
Tightening torque of road wheel nuts	The tightening torque should be the same as presented in table (5.7)	According to chapter (5.2.5)

When preparing the trailer for everyday use, check the individual components in accordance to the guidelines contained in the table (4.1).

**ATTENTION**

It is forbidden to use a defective trailer.

Before connecting the hydraulic system hoses, read the tractor manual and follow the manufacturer's instructions.

4.3 AGGREGATION WITH TRACTOR

The trailer may be connected to an agricultural tractor if all the connections and the coupling are in accordance with the trailer manufacturer's requirements.

Connecting with a tractor is only allowed if the agricultural tractor is equipped with a suitable hitch type.

**ATTENTION**

Before connecting the trailer, check the technical condition of the trailer and tractor coupling system as well as connecting elements of the hydraulic, electric and pneumatic system.

Aggregate only with a tractor equipped with a hitch that carries a vertical load of min. 2,000 kg. The tractor should have at least three hydraulic sections.

The trailer may only be connected when all preparatory activities and technical inspections have been completed successfully. If you experience alarming signals during your test drive like:

- noise and unnatural sounds from moving parts scraping on the trailer structure,
- hydraulic oil leak,
- pressure drop in the braking system,
- incorrect operation of hydraulic and / or pneumatic cylinders.

or other faults, you need to diagnose the problem. If the fault cannot be removed or its removal could invalidate the warranty, contact the sales point for clarification of the problem or repair.

Trailer conduits connectors and sockets on the tractor must be free of dirt. Pneumatic system connectors are equipped with rubber seals that cannot be damaged or contaminated.

DANGER



During aggregation, no unauthorized persons are allowed between the trailer and the tractor. When coupling the machine, the tractor driver should maintain extreme caution during operation and make sure that no unauthorized persons are present in the danger zone.

Before connecting the trailer, check the technical condition of the trailer and tractor coupling system as well as connecting elements for electrical, hydraulic and pneumatic systems.

Maintain extreme caution when connecting the machine.

When connecting the hydraulic hoses to the tractor, make sure that the tractor and trailer hydraulic systems are not under pressure.

When connecting the braking system lines, the correct order of connection is very important. First, connect the yellow connector to the yellow socket on the tractor, and then connect the red connector to the red socket on the tractor. After connecting the second conduit, the brake release system will switch to normal operation mode (disconnection or interruption of the air conduits causes the trailer control valve to automatically move to the position for actuating the pneumatic brakes of the machine).

In order to connect the trailer with the tractor, perform the following actions in order. The trailer should be immobilized with the parking brake.

Connecting the trailer

- ➔ Position the agricultural tractor in front of the trailer's drawbar.
- ➔ Adjust the height of the drawbar eye to the hitch of the tractor using the drawbar support.
- ➔ Reverse with the tractor, connect the drawbar eye.
- ➔ Check coupling safety device protecting trailer against accidental disconnection.
- ➔ Turn off tractor ignition.
- ➔ Raise the support foot.

- ➔ Connect the yellow pneumatic conduit.
- ➔ Connect the red pneumatic conduit.
- ➔ Connect the lighting and signaling installation electrical cable.
- ➔ Connect the red hydraulic hoses of the conveyor mechanism.
- ➔ Connect the black hydraulic hoses of the tailgate system.
- ➔ Connect the blue hydraulic hose of the steering lock system.
- ➔ Connect the hydraulic hoses of the front tilting extension.
- ➔ Connect the PTO shaft.

ATTENTION



The trailer may be aggregated only with a tractor that meets the requirements related to the minimum power demand, has the appropriate connection sockets for the braking and hydraulic system, the hydraulic oil in both machines is of the same grade and the tractor hitch can withstand the vertical load of the loaded trailer's drawbar. Check that the tractor PTO shaft corresponds to the trailer manufacturer's requirements. Check shaft rotation direction.

After completing aggregation, secure the hydraulic, braking and electrical wiring in such a way that they do not get pulled in by the moving parts of the tractor during travel and are not exposed to breakage or cutting when turning.

When connecting the control lines for the operation of individual hydraulic circuits, make sure that the corresponding pairs of lines are not mixed up. The cables are marked with information labels.

4.3.1 SUPPORT FOOT HANDLING

Setting the correct height of the drawbar eye relative to the tractor's hitch is obtained by using a support with a mechanical gear - figure (4.1).

Raising the support

- ➔ Remove safety pin (3).
- ➔ Push the foot (2) into the support body.
- ➔ Reinsert the locking pin.
- ➔ Turn the crank counterclockwise to raise the support foot (2) as much as possible.

Lowering the support

- ➔ Remove the safety pin.
- ➔ Pull the foot out of the support body.
- ➔ Reinsert the locking pin.
- ➔ Turning the crank clockwise, lower the support to the ground, or adjust the height of coupling in relation to the hitch (if the trailer is to be coupled with the tractor).

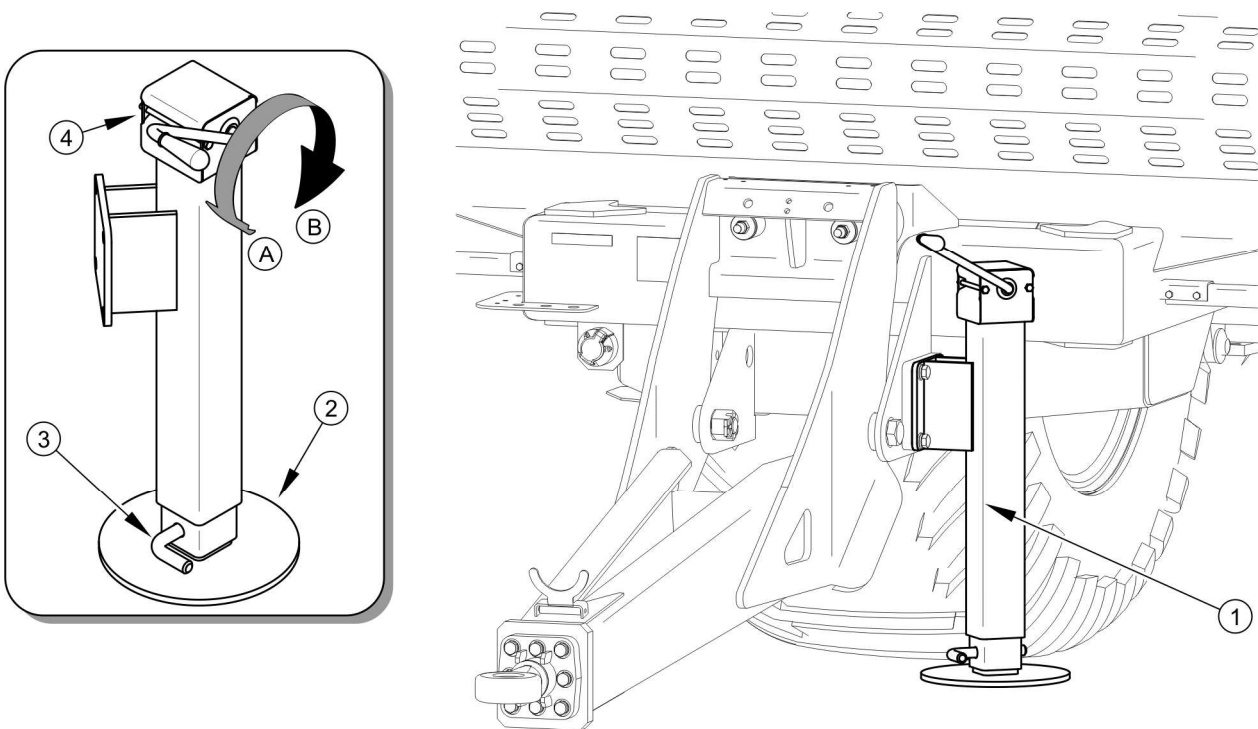

Figure 4.1 Support foot

(1) support, (2) foot, (3) safety pin, (4) mechanical gear, (A) raising, (B) lowering



ATTENTION

It is forbidden to leave the uncoupled and loaded trailer supported by the support at standstill.

Before driving off make sure that the support is set in driving position and locked with a safety bolt.

4.4 LOADING

Loading the load box can only take place when the trailer is connected to the tractor and placed on level ground. The load should be evenly distributed in the load box. This will ensure proper stability of the trailer while driving and correct axle and drawbar eye load. It is recommended to use a loader or conveyor when loading. Loading of silage in the field can be done directly from a forage harvester or combine harvester.

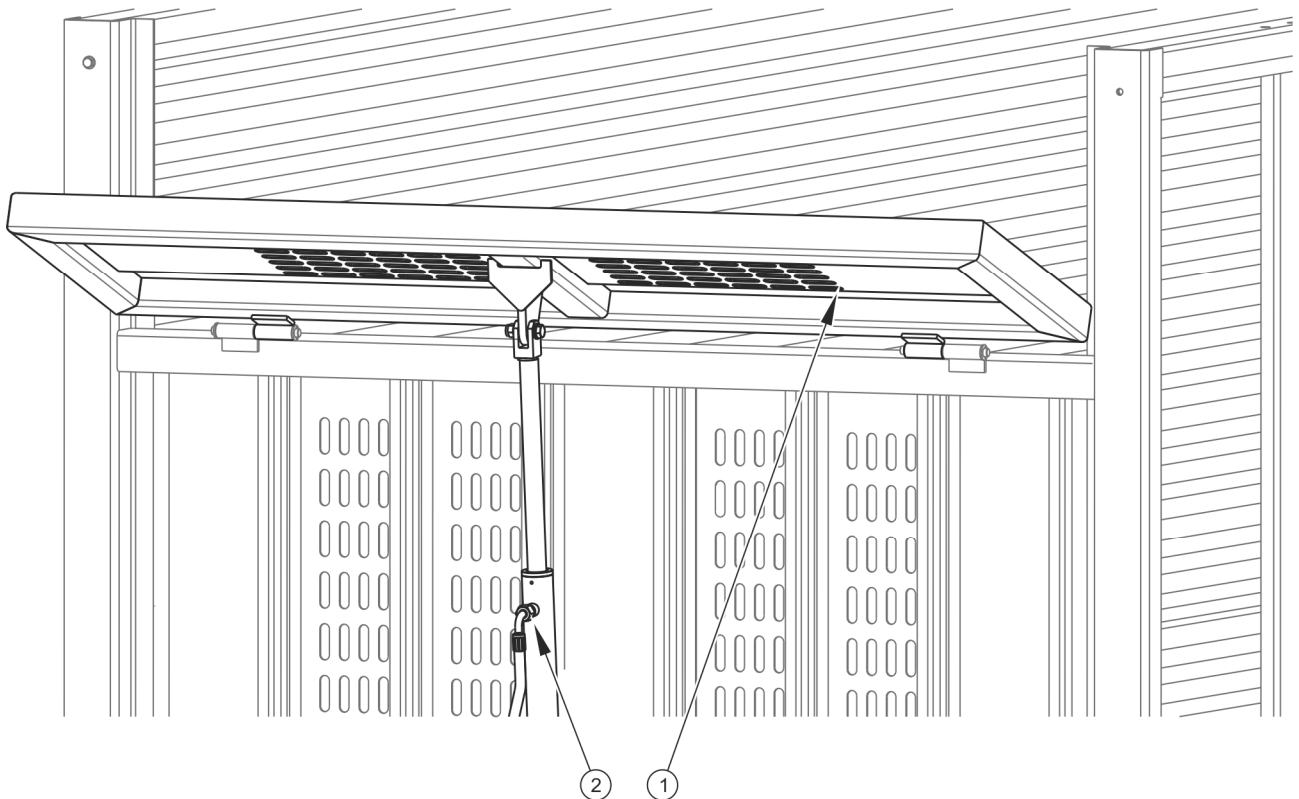

Figure 4.2 Front tilting extension

(1) front tilting extension, (2) hydraulic cylinder



ATTENTION

It is forbidden to exceed the trailer's maximum load capacity as it endangers safety during travel and may cause damage to the machine.

The load in the trailer's load box must be distributed evenly and must not hinder driving. Loading work should be carried out by a person experienced in this type of work.

Before loading, make sure the tailgate is closed. Check that there are no objects or people in the load box. Avoid dropping loads that can damage the trailer from height. The use of other loads than those foreseen by the Manufacturer is prohibited.

In order to facilitate loading by reducing the height of the front wall of the trailer, it is recommended to open the front tilting extension - figure (4.2).

Due to the different density of materials, the use of the total load box volumetric capacity may exceed the maximum mass load capacity of the trailer. Approximate specific volumetric weight of selected materials is presented in table (4.2). Pay special attention not to overload the trailer.

DANGER



It is forbidden to transport people and animals.

The trailer is designed for transporting crops and voluminous products. Transport of other loads specified in TABLE (4.2) is allowed.

When loading while driving, keep a constant distance between the machines and align the travel speed with the forage harvester or combine.

The hydraulic system of the front extension during operation is under pressure, use it maintaining extreme caution.

Table 4.2 APPROXIMATE SPECIFIC VOLUMETRIC WEIGHT OF SELECTED MATERIALS

MATERIAL	VOLUMETRIC WEIGHT kg/m ³
Mulches and voluminous fodder:	
dry meadow hay on swath	10 - 18
Wilted hay on swath	15 - 25
hay in a collecting wagon (dry, wilted)	50 - 80
cut wilted hay	60 - 70
pressed dry hay	120 - 150
wilted dry hay	200 - 290
stored dry hay	50 - 90
stored cut hay	90 - 150
wilted clover (Lucerne) on swath	20 - 25

MATERIAL	VOLUMETRIC WEIGHT kg/m ³
cut wilted clover (Lucerne) in a trailer	110 - 160
wilted clove (Lucerne) in a collecting wagon	60 - 100
stored dry clove	40 - 60
cut stored dry clove	80 - 140
dry straw in rollers	8 - 15
wet straw in rollers	15 - 20
cut wet straw in a voluminous trailer	50 - 80
cut dry straw in a voluminous trailer	20 - 40
dry straw in a collecting wagon	50 - 90
cut dry straw in a stack	40 - 100
pressed straw (low press level)	80 - 90
pressed straw (high press level)	110 - 150
cereal mass in rollers	20 - 25
cut cereal mass in a voluminous trailer	35 - 75
cereal mass in a collecting wagon	60 - 100
green fodder on swath	28 - 35
cut green fodder in a voluminous trailer	150 - 400
green fodder in a collecting wagon	120 - 270
fresh fodder beetroot leaves	140 - 160
cut fresh fodder beetroot leaves	350 - 400
fodder beetroot leaves in a collecting wagon	180 - 250
Concentrated fodder and fodder mix:	
stored chaff	200 - 225
oil cake	880 - 1 000
dried mince	170 - 185
silage (pit silo)	50 - 1 050
hay silage (tower silo)	550 - 750

Source: „Technologia prac maszynowych w rolnictwie”, PWN, Warszawa 1985

4.5 UNLOADING

The unloading of the Pronar T400 trailer load box is done by opening the tailgate (2) and activating the conveyor mechanism (3). In additional equipment the trailer has dosing drums (4), which facilitate unloading of transported cargo. The hydraulic conveyor mechanism is used for automatic unloading of the trailer. This solution ensures unloading of transported materials in difficult conditions, e.g. in low buildings, on slopes or during winds when unloading by tipping the load box could not be carried out.

DANGER



It is forbidden to unload the trailer on an unstable surface.

Maintain extreme caution when closing the tailgate, as damage may cause serious injury.

It is forbidden to stay in the load box during unloading.

Maintain extreme caution when handling dosing drums due to rotating power transmission elements.

When unloading with dosing drums, make sure that there are no persons in the unloading area because of the possibility of foreign bodies (stones, branches, etc.) being thrown out when the rollers are turning.

Unloading the trailer should be carried out in the following order:

- ➔ During unloading place, the trailer on a stable surface.
- ➔ Place the tractor for forward travel.
- ➔ Open the tailgate (2) to maximum level by adjusting the appropriate lever of the tractor's hydraulic distributor.
 - ⇒ If the trailer is equipped with dosing drums (4), turn on the PTO drive and set the speed to 540 rpm.
- ➔ Activate the floor conveyor mechanism (3) using the lever of the tractor's hydraulic distributor.
- ➔ After emptying the load box, turn off the conveyor mechanism.
 - ⇒ If the trailer is equipped with dosing drums, turn off the PTO drive.
- ➔ Clean the rear edges of the load box and tailgate.

➔ Close the tailgate.

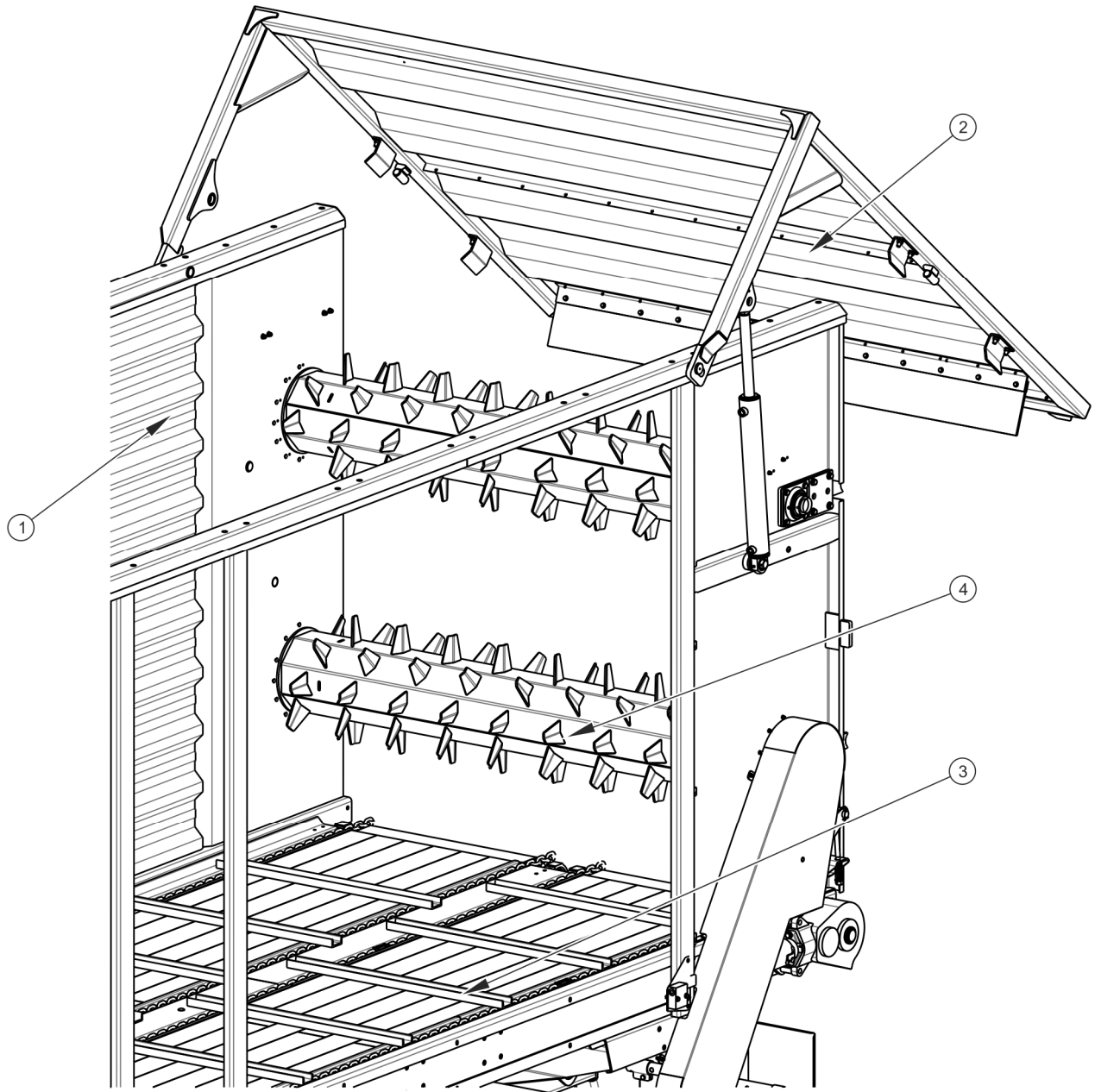

Figure 4.3 Unloading the load box

(1) load box, (2) tailgate, (3) floor conveyor mechanism, (4) dosing drums

4.6 TRANSPORT OF LOAD

While driving, comply with traffic regulations, be prudent and reasonable. The following are the most important tips for managing the set.

- Before moving off make sure that there are no bystanders, especially children, near the trailer and tractor. Ensure proper visibility.
- Make sure that the trailer is correctly coupled to the tractor and tractor's hitch is properly secured.
- It is forbidden to drive on public roads with the tailgate raised.
- The trailer must not be overloaded, loads must be evenly distributed in such a way that they do not exceed the permissible axle or the drawbar eye loads. Exceeding the maximum load capacity of the trailer is forbidden and may cause damage to the machine, and may also constitute a danger during travel for the operator or other road users.
- The permissible design speed and speed resulting from restrictions of road traffic regulations must not be exceeded. The travel speed should be adjusted to the road conditions, trailer load condition, road condition and other conditions.
- The trailer disconnected from the tractor must be secured by immobilizing it with the parking brake and possibly placing chocks or other elements without sharp edges under the wheels. Leaving an unsecured trailer is prohibited. In the event of a trailer failure, stop at the side of the road without endangering other road users and mark the stopping place in accordance with traffic regulations.
- The tractor operator is required to equip the trailer with a certified or approved warning reflective triangle (SMV plate). While driving, obey the rules of the road traffic, signal the change of direction by means of direction indicators, keep the lighting and signaling installation clean and take care of its technical condition. Damaged or lost lighting and signaling components must be repaired or replaced immediately.
- Avoid ruts, depressions, ditches, or driving along roadside slopes. Driving through these types of obstacles can cause the machine and tractor to tilt suddenly. This is particularly important because the center of gravity of the laden trailer adversely affects driving safety. Driving near the edges of ditches or canals is dangerous due to the risk of landslides under the wheels of vehicles.
- When traveling on public roads, the trailer must be marked with a slow-moving vehicle plate (SMV plate), located on the rear wall of the load box.

- It should be kept in mind that the braking distance of the set increases significantly with the increase in the weight of the transported load and the increase in speed.
- Reduce your speed sufficiently in advance of approaching bends, when driving on uneven or sloping terrain.



ATTENTION

It is forbidden to drive on public roads with the tailgate raised.

- When reversing, lock the steering axle in the straight-ahead position.

4.7 DISCONNECTION FROM TRACTOR

In order to disconnect the trailer from the tractor, perform the following actions:

- ➔ After stopping the tractor, immobilize the trailer with parking brake, Activate the park brake with crank mechanism - see figure (3.12).
- ➔ Place chocks under the rigid axle wheel.
- ➔ Use the support to set the drawbar eye at the appropriate height - see section 4.3.1.
- ➔ Reduce residual pressure in the hydraulic system by moving the appropriate lever to control the hydraulic circuit of the tractor.
- ➔ Turn off tractor engine. Close the tractor cabin and secure it against unauthorized access.
- ➔ Disconnect electric, hydraulic and braking system conduits from the tractor. Protect the ends of these conduits pipes from contamination. Close the hydraulic system's connectors with caps and place them in special holders located on the trailer frame.
- ➔ Close the pneumatic system connectors with caps and place on appropriate holders located on the trailer frame.
- ➔ Disconnect trailer drawbar eye from tractor's hitch and drive tractor away.

- ➔ When disconnecting pneumatic system lines, first disconnect the cable with the red connector, and then the cable with the yellow connector.



ATTENTION

The trailer disconnected from the tractor should be immobilized by means of the parking brake, chocks should be placed under the wheel of the rigid axle.

4.8 PRINCIPLES OF TIRES USE

- When working with tires, secure the trailer against rolling away by placing chocks or other elements without sharp edges under the wheels. The wheel can be dismantled only when the trailer is not loaded.
- Repair work on wheels or tires should be carried out by persons trained and authorized to do so. These works should be carried out using appropriately selected tools.
- Regularly check and maintain proper tire pressure as recommended in the instructions (especially after a long break of not using the trailer).
- Tire pressure should also be checked during all-day intensive work. It should be taken into account that the increase in tire temperature can increase the pressure by up to 1 bar. With such a rise in temperature and pressure, reduce the load or speed.
- Never reduce the pressure by venting if it increases due to temperature rise.
- Tire valves must be protected with suitable caps to avoid their dirtiness.
- Do not exceed the maximum design speed of the trailer.
- Avoid damaged road surfaces, sudden and variable maneuvers, and high speeds when turning.
- Obey the 30 minutes breaks for cooling the tires after driving 75 km or after 150 minutes of continuous drive depending on what happens first.
- Checking the nut tightness should be carried out after the first use of the trailer, after the first ride with a load and then every 6 months of use, or every 25,000 km.

In the case of intensive work, tightening checks should be carried out at least once every 10,000 kilometers. In each case, the inspection activities should be repeated if the trailer wheel was disassembled.

CHAPTER

5

TECHNICAL SERVICE

5.1 BASIC INFORMATION

When using the trailer, it is necessary to constantly check the technical condition and perform maintenance procedures that will allow to keep the vehicle in good technical condition. Therefore, the trailer user is obliged to perform all maintenance and adjustment activities specified by the Manufacturer. Repairs during the warranty period may only be carried out by authorized service centers.

This chapter describes in detail the procedures and scope of activities that the user can perform on his own. In the event of unauthorized repairs, changes in factory settings or activities which were not considered to be carried out by the trailer operator, the user loses the warranty.

5.2 BRAKES AND AXLE SERVICE

5.2.1 BASIC INFORMATION

Work related to the repair, replacement or regeneration of axle elements and mechanical brakes should be entrusted to specialized workshops that have the appropriate technologies and qualifications to perform this type of work.

The user's obligations include only:

- checking and adjusting the clearance of the axle bearings
- wheel assembly and disassembly, checking wheel nuts tightness
- control and maintenance of air pressure, assessment of the technical condition of wheels and tires.
- checking brake lining thickness,
- adjustment of mechanical brakes.

Activities related to:

- replacement of grease in axle bearings,
- replacement of bearings, hub seals,
- replacement of brake shoes,

- other axle repairs.

Can only be carried out by specialized workshops.



DANGER

It is forbidden to use the trailer with defective brakes installation.

5.2.2 AXLE BEARING CLEARANCE CONTROL

Preparatory activities

- ➔ Hitch trailer to tractor, immobilize the tractor with parking brake.
- ➔ Place the tractor and the trailer on firm and level ground.
 - ⇒ Place the tractor for straight travel.
- ➔ Place blocking chocks under trailer wheel which will not be lifted. Ensure that the trailer will not roll away during inspection.
- ➔ Raise the wheel (located on the opposite side of the placed wedges).
 - ⇒ The jack should be placed between the U-bolts (2) figure (5.1) mounting the axle (1) to the lower frame (3), or as close as possible to the spring mount. Recommended support points are marked with arrows. The jack must be adjusted to the weight of the trailer.

Checking the clearance of the axle bearings

- ➔ Turning the wheel slowly in two directions, check that the movement is smooth and the wheel rotates without excessive resistance and jamming.
- ➔ Turn the wheel so that it rotates very quickly, check that the bearing does not make any unusual sounds.
- ➔ Holding the wheel above and below, try to feel the clearance.
 - ⇒ A lever can be put under the wheel, resting the other end on the ground.
- ➔ Repeat the checking procedure for the other wheels.

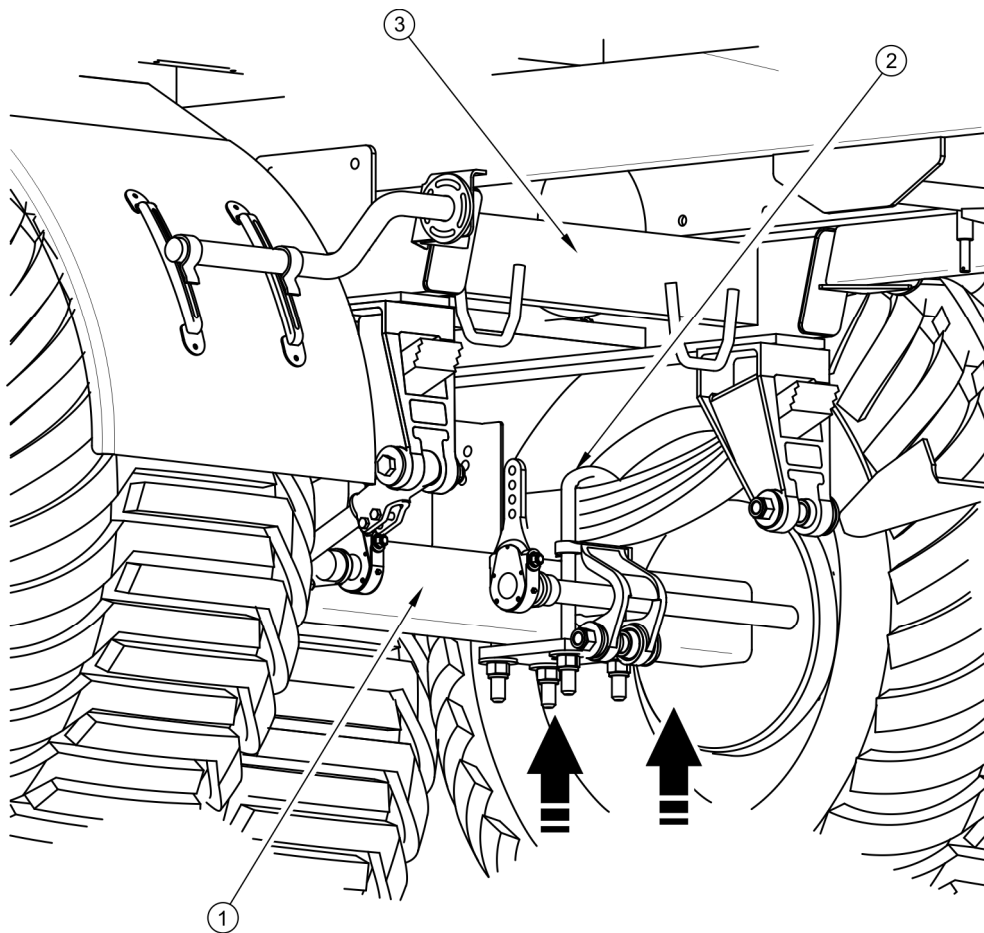



Figure 5.1 Jacking points

(1) axle, (2) U-bolt, (3) lower frame



Checking the clearance of the axle bearings:

- after covering the first 1,000 km,
- during intensive use of the trailer at least every 10,000km,
- every six months of use or every 25,000 km.

If clearance is palpable, adjust the bearings. Unnatural sounds coming from the bearing may be symptoms of excessive wear, dirt or damage. In this case, the bearing, together with the sealing rings, must be replaced or cleaned and regreased. When checking bearings, make sure that any noticeable clearance comes from the bearings and not from the suspension system (e.g. looseness on the spring pins, etc.).

**TIP**

Damaged hub cover or lack of it will cause the penetration of dirt and moisture into the hub, which will result in much faster wear of bearings and hub seals. Bearing life depends on trailer operating conditions, load, vehicle speed and lubrication conditions.

Check the technical condition of the hub cover, replace if necessary. Checking bearing clearance can only be carried out when the trailer is connected to the tractor and the load box is empty.

**DANGER**

Before starting work, read the jack operators manual and follow the manufacturer's instructions.

The lift must rest firmly on the ground and against the drive axle.

Ensure that the trailer will not roll away during inspection of the axle bearings clearance.

5.2.3 AXLE BEARING CLEARANCE ADJUSTMENT

The wheel should rotate smoothly, without any jams or noticeable resistance not coming from rubbing the shoes on the brake drum. Adjustment of bearing clearance may be performed only when the trailer is connected to the tractor and the load box is empty. Ensure that the trailer is properly secured and will not roll away during dismantling.

Adjusting the axle bearing clearance

- ➔ Remove the hub cover (1) - figure (5.2).
- ➔ Remove the cotter pin (3) securing the castellated nut (2).
- ➔ Tighten the castellated nut to remove clearance.
 - ⇒ The wheel should rotate with slight resistance.
- ➔ Unscrew the nut (not less than 1/3 turn) to cover the nearest nut groove with a hole in the axle journal. The wheel should rotate without excessive resistance

⇒ The nut may not be tightened too much. It is not recommended to apply too much force due to deterioration of the operating conditions of the bearings.

- ➔ Secure castellated nut with cotter pin and mount hub cover.
- ➔ Gently tap the hub with a rubber or wooden hammer.

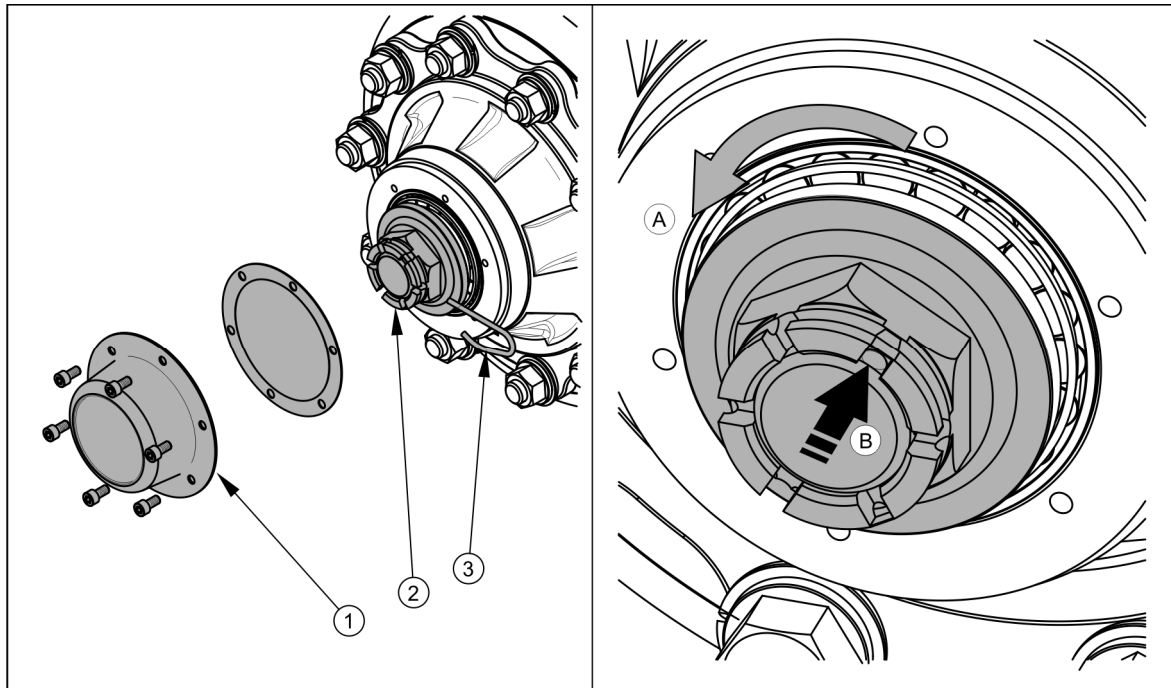

Figure 5.2 Axle bearings adjustment

(1) hub cover, (2) castellated nut, (3) cotter pin



TIP

If the wheel is dismounted, bearing clearance is easier to check and adjust.

5.2.4 MOUNTING AND DISMOUNTING THE WHEEL, CHECKING BOLT CONNECTIONS

Wheel dismounting

- ➔ Immobilize trailer with parking brake.

- ➔ Place chocks under the trailer wheel opposite to the dismantled one.
- ➔ Ensure that the trailer is properly secured and will not roll away during wheel dismantling.
- ➔ Loosen wheel nuts in the order given in figure (5.3)
- ➔ Place the jack and raise the trailer on such height that the wheel being changed does not rest on the ground.
 - ⇒ The jack used should have adequate load capacity and be technically sound.
 - ⇒ The jack must be placed on a level, solid surface that will not allow it to penetrate the surface or slip during operation.
 - ⇒ If necessary, use properly selected sleepers reducing the unit pressure of the lift base on the ground, eliminating penetration into the ground.
- ➔ Remove the wheel.

**TIP**

Wheel nuts should be tightened to 570 Nm - M22x1.5 nuts.

Wheel installation

- ➔ Clean axle pins and nuts from dirt.
 - ⇒ Do not lubricate the threads of the nut and pin.
- ➔ Check technical condition of pins and nuts, replace if necessary.
- ➔ Mount the wheel on the hub, tighten the nuts so that the rim fits tightly onto the hub.
- ➔ Lower trailer, tighten nuts according to recommended torque and given order.

Tightening the nuts

The nuts should be tightened gradually diagonally (in several stages until the required tightening torque is achieved), using a torque wrench. If you do not have a torque wrench,

you can use a regular key. The key arm (L), figure (5.3) should be selected according to the weight of the operator (F) tightening the nut. It should be kept in mind that this method of tightening is not as accurate as when using a torque wrench.

ATTENTION



Wheel nuts must not be tightened with impact wrenches, due to the danger of exceeding the permissible tightening torque, which may result in breaking the thread of the connection or breaking the hub pin.

The highest tightening accuracy is obtained with a torque wrench. Before starting work, make sure that the correct torque value is set.

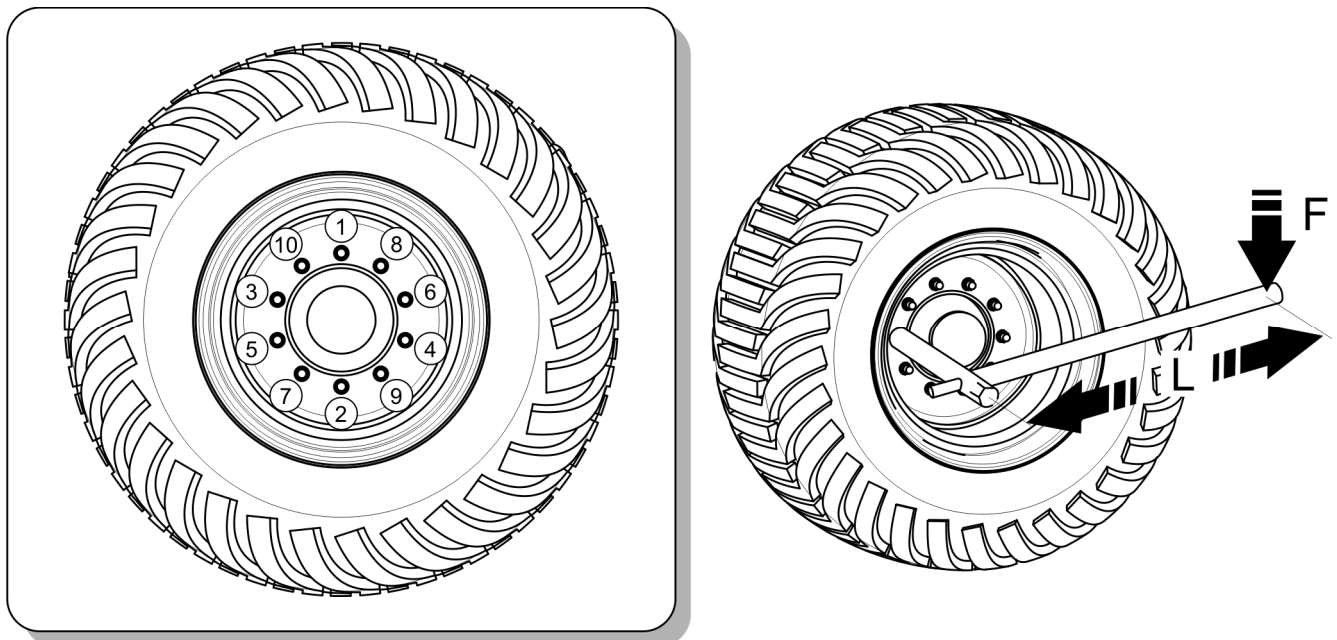

Figure 5.3 Nuts tightening order

(1) - (6) nuts tightening order, (L) key length, (F) operators' weight

Table 5.1 Choice of the key length

WHEEL TIGHTENING TORQUE	OPERATOR'S WEIGHT (F)	KEY LENGTH (L)
[NM]	[KG]	[M]
570	90	0.65
	75	0.75
	65	0.88
	60	0.95

Checking wheel nuts tightness:

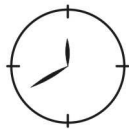

- after the first use of the trailer,
- after the first use with load,
- after covering the first 1,000 km and every 6 months of use or every 25,000 km.

In case of intensive use of the trailer, the inspection should be carried out at least every 10,000 km.

5.2.5 AIR PRESSURE CONTROL, TIRES AND RIMS TECHNICAL CONDITION INSPECTION

The tire pressure should be checked after changing the spare wheel and at least once a month. In case of intensive use, it is recommended to check the air pressure more often. The trailer must be unloaded during control. Control should be carried out before driving, when the tires are not warm, or after a long standstill of the machine.



TIP

The value of the tire pressure is specified on the information label, placed on the rim or upper frame, above the trailer wheel.

When checking pressure, pay attention to the technical condition of rims and tires. Look carefully at the side surfaces of the tires and check the condition of the tread.

DANGER



Damaged tires or wheels can be a cause of a serious accident.

In the event of mechanical damage, consult your nearest tire service center and make sure if the defect in the tire qualifies it for replacement.

Rims should be checked for deformation, material cracks, weld cracks, corrosion, especially around welds and contact with the tire.

Technical condition and appropriate maintenance of wheels significantly extends the life of these elements and ensures an appropriate level of safety for trailer users.



Pressure control and visual inspection of steel wheels:

- every 1 month of use,
- if necessary.

5.2.6 CHECKING THE BRAKE LINING WEAR



TIP

The minimum thickness of the brake linings is 5 mm.

While using the trailer, the drum brake linings will wear out. In such case, whole brake shoes should be replaced. Excessive wear of the brake shoes is a condition in which the thickness of the brake linings glued or riveted to the steel structures of the shoes exceeds the minimum value and is manifested by the extension of the cylinder piston stroke. Assessment of the technical condition of the brake linings should be carried out through the control holes (3) - figure (5.4).



- **Checking of the lining thickness should be carried out every 6 months.**

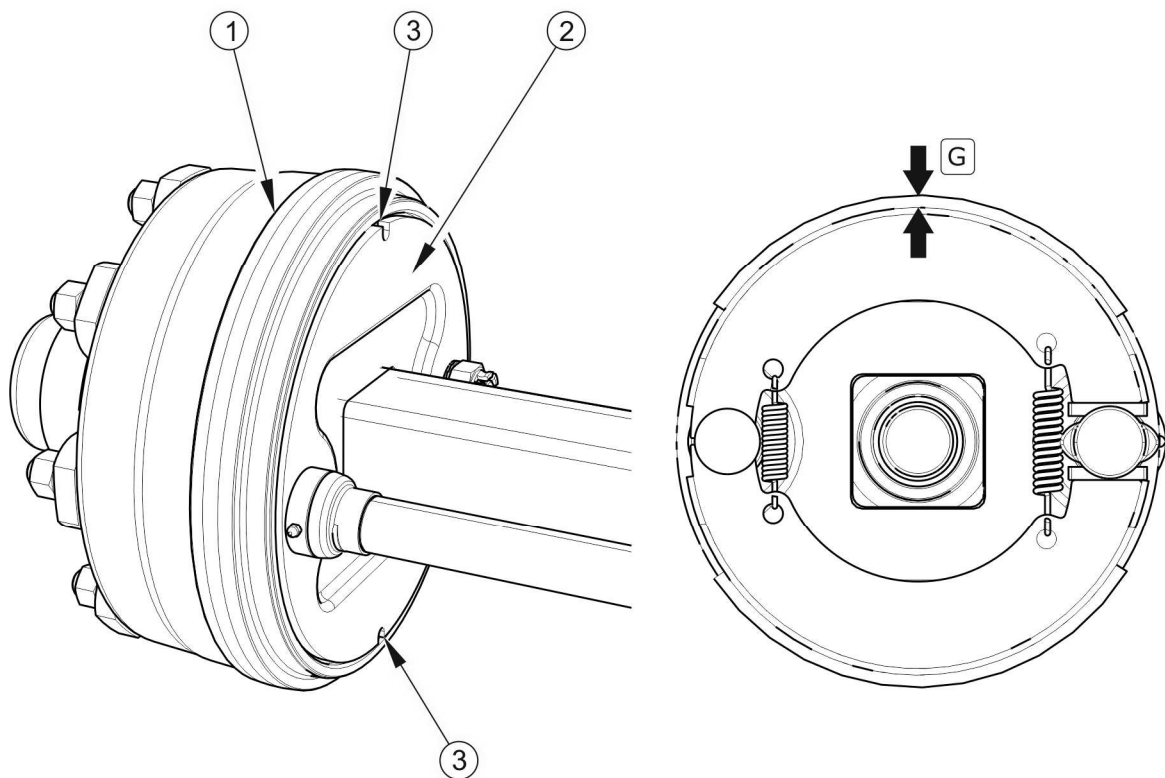

Figure 5.4 Brake shoes inspection

(1) brake drum, (2) brake chamber wall, (3) control holes, (G) lining thickness

5.2.7 MECHANICAL BRAKES REGULATION

Significant lining wear increases the stroke of the brake cylinder piston and deteriorates braking performance.



TIP

The correct stroke of the piston rod should be in the range of 25 - 45 mm.

When braking, the piston rod stroke should be within the specified working range, and the angle between the piston rod (1) and the expander arm (3) should be approximately 90° - compare figure (5.6).

The braking force also decreases when the angle of the piston rod of the brake cylinder (5) is not correct - figure (5.5) in relation to the expander arm (1). To obtain the optimum mechanical angle of operation, the cylinder fork (6) must be mounted on the expander arm (1) in such way, that when fully braked, the angle of operation is approx. 90° .



ATTENTION

An incorrectly adjusted brake can cause the shoes to rub against the drum, which may result in faster wear of the brake linings and / or overheating of the brake.

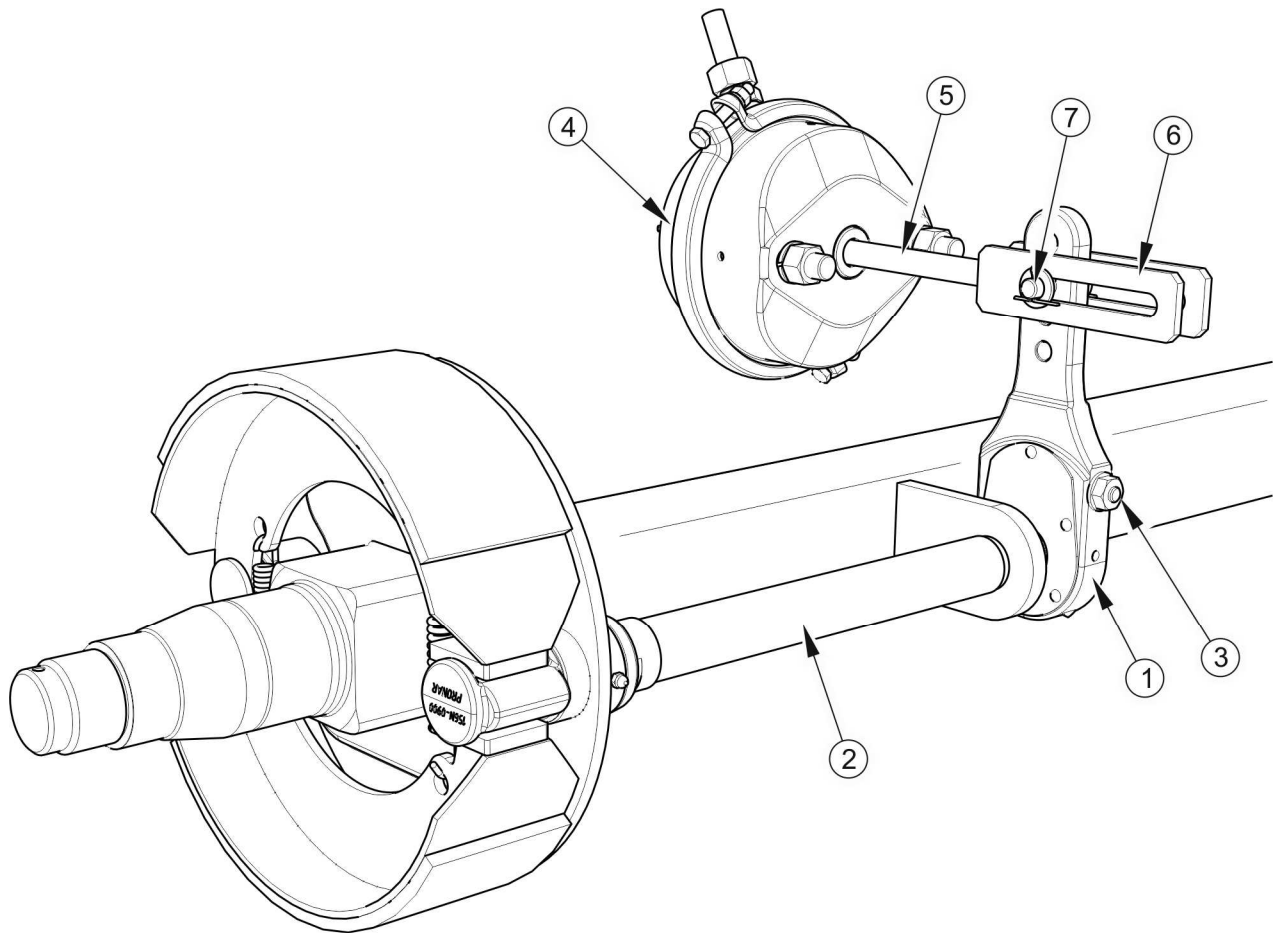

Figure 5.5 Drive axle brake construction

(1) expander arm, (2) expander shaft, (3) regulation screw, (4) brake cylinder, (5) piston rod, (6) cylinder fork, (7) fork pin



- Check the technical condition of the brake every 6 months

The control involves measuring the extension length of each piston rod during braking at a standstill. If the piston rod stroke exceeds the maximum value (45 mm), the system should be adjusted.

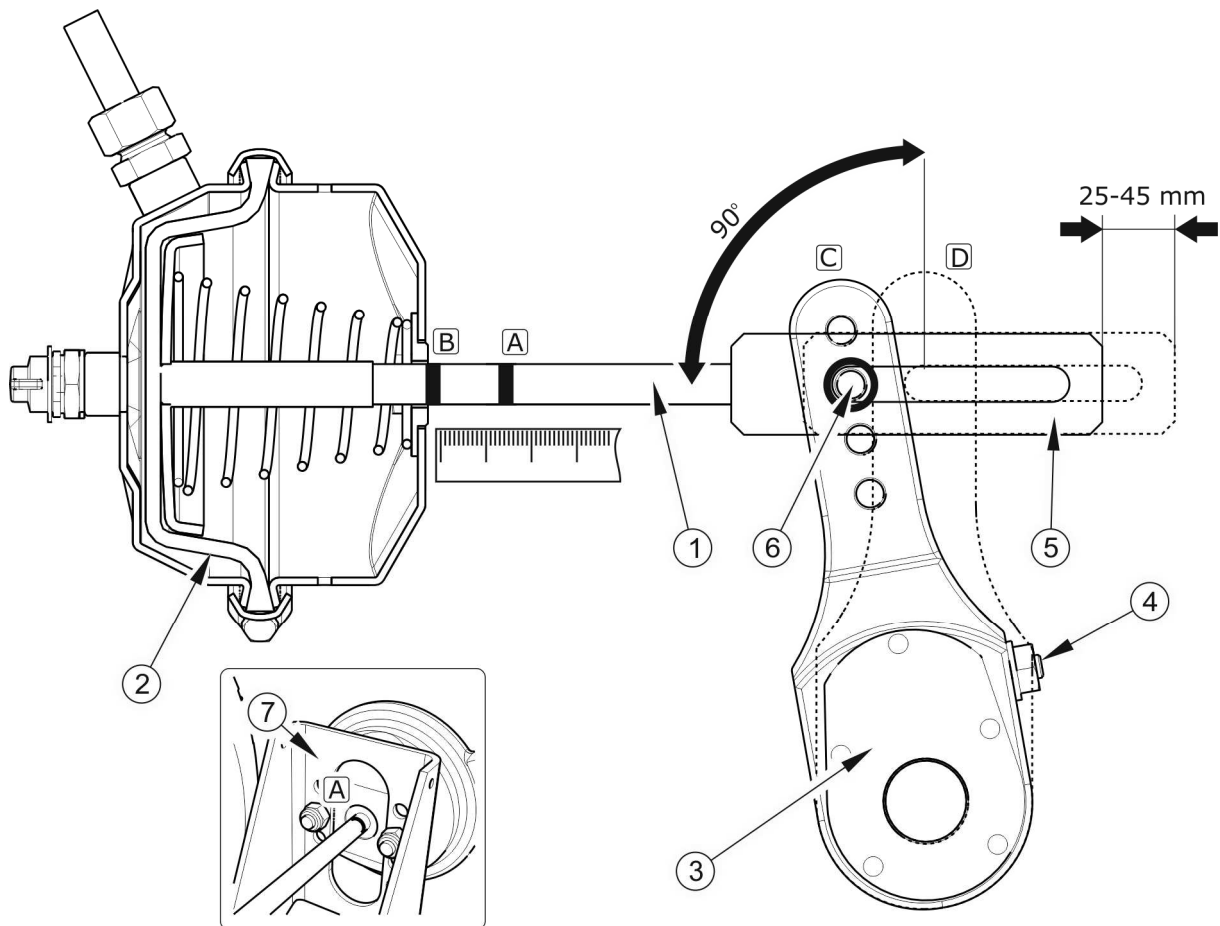

Figure 5.6 Brake adjustment rule

(1) piston rod, (2) cylinder diaphragm, (3) expander arm, (4) control screw, (5) cylinder fork, (6) fork pin position, (7) cylinder bracket, (A) marker on the piston while unbraked, (B) marker on the piston when fully braked, (C) expander arm position when unbraked, (D) expander arm position when fully braked

The scope of service activities

- ➔ Hitch the trailer to the tractor.
- ➔ Turn off the tractor engine and remove the ignition key.
- ➔ Immobilize the tractor with parking brake.
- ➔ Make sure that the trailer is not braked.

- ➔ Secure the trailer against rolling away using wheel chocks.
- ➔ Mark the position of piston rod (1) during maximum retraction when the trailer is unbraked with line (A)
- ➔ Press the brake pedal on the tractor, mark the position of maximum extension of the piston rod with line (B).
- ➔ Measure the distance between the lines (A) and (B). If the piston rod stroke is not within the correct working range, adjust the expander arm.
- ➔ Remove the cylinder fork pin.
- ➔ Memorize or mark the original position of the cylinder fork (5) pin (6) - figure (5.6), in the expander arm hole (3).
- ➔ Check whether the cylinder piston moves freely and within the full nominal range.
- ➔ Check that the actuator's ventilation openings are not clogged with dirt and that there is no water or ice inside. Check the correct mounting of the actuator.
- ➔ Clean the actuator, defrost if necessary and remove water through the unblocked ventilation holes. If any damage is found, replace the actuator with a new one. When mounting the actuator, keep its original position relative to the bracket (7).
- ➔ Turn the adjusting screw (4) so that the marked hole of the expander arm coincides with the hole of the cylinder fork
 - ⇒ During adjustment, the diaphragm (2) must rest on the rear wall of the actuator - see figure (5.6).
- ➔ Mount the piston rod fork pin, pads and secure the pin with cotter pins.
- ➔ Turn the adjusting screw (4) clockwise to make one or two clicks in the expander arm adjustment mechanism.
- ➔ Repeat the adjustment on the second cylinder on the same axis.
- ➔ Apply the brake.
- ➔ Wipe the previous marks and measure the piston rod stroke again.

- ➔ If the piston rod stroke is not within the correct operating range, repeat the adjustment.



- Before a period of intensive use.
- Every 6 months.
- After repairing the braking system.
- In case of uneven braking of the trailer wheels.



ATTENTION

The mounting positions of the brake cylinder in the bracket holes and the cylinder pin in the expander arm are determined by the Manufacturer and cannot be changed.

Whenever removing the pin or actuator, it is recommended to mark the original location.

5.2.8 PARKING BRAKE STRING REPLACEMENT AND TENSNESS REGULATION

The correct operation of the parking brake depends on the effectiveness of the brakes of the axle and the correct tension of the brake string.

Parking brake cable replacement

- ➔ Hitch the trailer to the tractor. Place the trailer and tractor on a level surface.
- ➔ Place chocks under the trailer wheel.
- ➔ Loosen the nuts (6) of the string clamps (5).
- ➔ Remove the string (4).
- ➔ Lubricate the parking brake mechanism (1) and the pins of the string guide wheels (3).
- ➔ Insert new string, adjust string tension.

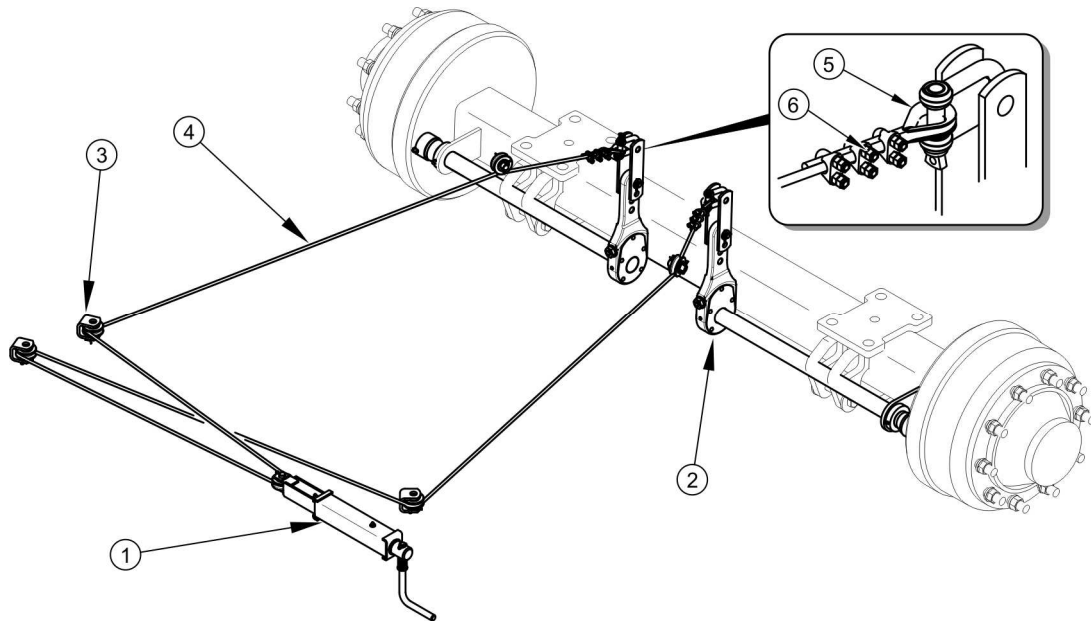

Figure 5.7 Adjustment of parking brake string tension

(1) brake crank mechanism, (2) expander arm, (3) guide wheel with mounting, (4) parking brake string, (5) bow clamp, (6) clamp nuts

Adjustment of parking brake string tension

- ➔ Hitch the trailer to the tractor. Place the trailer and tractor on a level surface.
- ➔ Place chocks under the trailer wheel.
- ➔ Unscrew the brake mechanism screw (1) as far as possible (counterclockwise)
- ➔ Loosen nuts (6) of handbrake string clamps (5).
- ➔ Tighten the cable (4) and tighten the clamps.

⇒ The length of the parking brake string should be chosen so that when the service and parking brake is completely released, the string is loose and hangs down about 1-2 cm.

Adjustment of parking brake cable tension should be carried out in the case of:

- string stretching,
- loosening the parking brake string clamps,
- after adjusting the axle brake,
- after repairs to the axle brake system,

- after repairs to the parking brake system.

Before starting the adjustment, make sure that the brakes on the axles are correctly adjusted and function properly.



Parking brake control and / or adjustment:

- every 12 months,
- if necessary.

5.3 PNEUMATIC SYSTEM SERVICE

5.3.1 BASIC INFORMATION

Work related to the repair, replacement or regeneration of system components (brake cylinders, lines, control valve, braking force regulator, etc.) should be entrusted to specialized workshops that have the appropriate technologies and qualifications to perform this type of work.

The user's obligations related to the operation of the pneumatic system include:

- checking system tightness and visual inspection of the system,
- cleaning the air filters,
- air tank drainage,
- cleaning the drain valve,
- cleaning and maintenance of pneumatic hose connections,
- replacement of the pneumatic conduit.



DANGER

It is forbidden to use the trailer with defective braking system.

5.3.2 AIRTIGHTNES CONTROL AND VISUAL INSPECTION

Checking the tightness of pneumatic systems

- ➔ Hitch the trailer to the tractor.
- ➔ Immobilize tractor and trailer with parking brake. Additionally, place chocks under the wheel of the trailer.
- ➔ Start the tractor to refill the air in trailer braking system tank.
 - ⇒ In two-line systems, the air pressure should be around 8 bar.
- ➔ Turn off tractor engine.
- ➔ Check system components with the tractor brake pedal released.
 - ⇒ Pay special attention to cable connections and brake cylinders.
- ➔ Repeat the system check with the tractor brake pedal pressed.
 - ⇒ Help of another person is required.

In case of a leak, the compressed air will leak out in places of damage with a characteristic hissing. The system leak can also be detected by coating the controlled elements with washing liquid or other foaming agent, which will not aggressively affect the elements of the installation. It is recommended to use commercially available agents intended for leak detection. Damaged elements should be replaced or handed over for repair. If there is a leak around the connections, the user can tighten the connector on their own. If air still leaks, replace the connector or seal components with new ones.



Checking the installation for leaks:

- after covering the first 1,000 km,
- every time after repair or replacement of system components,
- once a year.

Visual assessment of the installation

When checking for leaks, pay attention to the technical condition and degree of cleanliness of the system components. Contact of pneumatic conduits, seals etc. with oil, grease, gasoline

etc. may damage them or accelerate the aging process. Bent, permanently deformed, cut or frayed cables are only eligible for replacement.



Visual assessment of the installation:

- carry out a visual inspection of the system at the same time as the tightness test.



ATTENTION

Repair, replacement or regeneration of pneumatic system components may only be carried out in a specialized workshop.

5.3.3 CLEANING THE AIR FILTERS

Depending on the trailer's working conditions, but not less than once every three months, the air filter cartridges, which are located on the pneumatic system connection hoses, should be removed and cleaned. Cartridges are reusable and should not be replaced unless they are mechanically damaged.

The scope of service activities

- ➔ Reduce pressure in the supply line.
 - ⇒ The pressure in the pipe can be reduced by pushing the plug of the pneumatic connection to maximum.
- ➔ Pull out the securing latch (1) - figure (5.8).
 - ⇒ Hold the filter cover (2) with the other hand. After removing the latch, the cover will be pushed out by the spring located in the filter housing.
- ➔ The filter element and filter body should be thoroughly washed with clean water and blown with compressed air. Installation should be in reverse order.



DANGER

Before removing the filter, reduce the pressure in the supply line. When removing the filter latch, hold the cover with the other hand. Point the filter cover away from you.

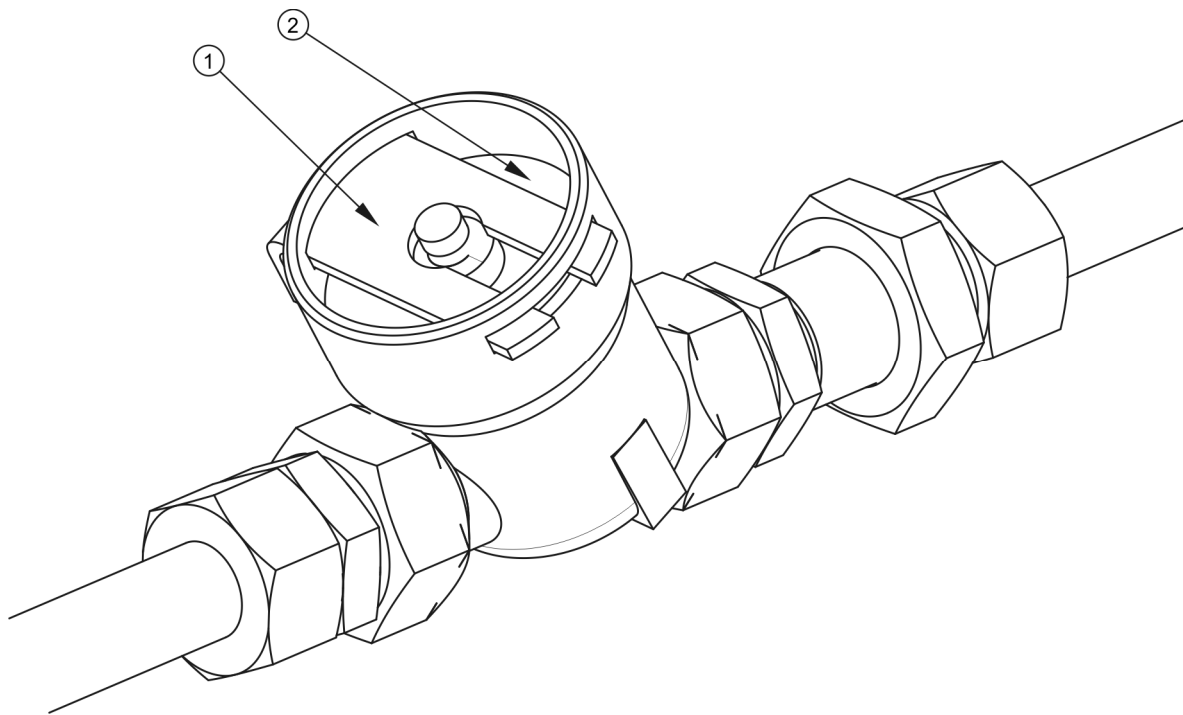

Figure 5.8 Air filter

(1) securing latch, (2) filter cover



Cleaning the air filter (filters):

- every 3 months of use.

5.3.4 DRAINAGE OF AIR TANKS

The scope of service activities

- Repeat the drain valve stem (1) located at the bottom of the tank (2) - the tank is located on the right longeron of the lower frame.
 - ⇒ The compressed air in the tank will blow out the water.
- After releasing the stem, the valve should close automatically and stop the outflow of air from the tank.
 - ⇒ If the valve stem does not want to return to its position, the entire drainage valve must be unscrewed and cleaned, or replaced with a new one (if it is damaged) - see chapter 5.3.5.

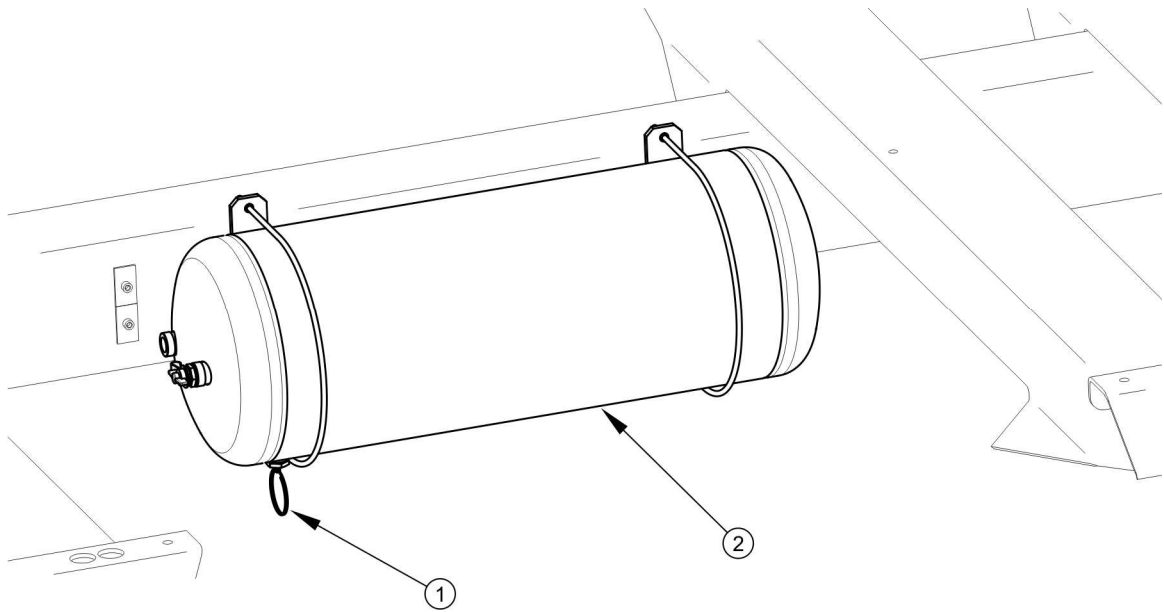

Figure 5.9 Air tank drainage

(1) drain valve, (2) air tank,



Air tank drainage:

- every seven days of use.

5.3.5 CLEANING OF DRAIN VALVE



DANGER

Bleed the air reservoir before removing the drain valve.

The scope of service activities

- ➔ Completely reduce the pressure in the air tank.
 - ⇒ Pressure reduction in the tank can be done by repealing the drain valve stem.
- ➔ Unscrew the valve.
- ➔ Clean the valve, blow with compressed air.

- ➔ Replace the copper seal.
- ➔ Screw in the valve, fill the tank with air, check the tank for leaks.

**Cleaning the valves:**

- every 12 months (before the winter period).

5.3.6 CLEANING AND MAINTAINANCE OF PNEUMATIC LINE CONNECTORS AND SOCKETS

**DANGER**

Faulty and dirty trailer connections can cause the braking system to malfunction.

A damaged connector body or socket should be replaced. In the event of damage to the cover or seal, replace these elements with new, functional ones. Contact of pneumatic connection seals with oils, grease, gasoline etc. may damage them and accelerate the aging process.

If the trailer is disconnected from the tractor, connections should be protected with covers or placed in their designated holders. Before the winter period, it is recommended to preserve the seal with preparations intended for this purpose (e.g. silicone lubricants for rubber elements).

Each time before connecting the machine, check the technical condition and cleanliness of connections and sockets in the agricultural tractor. If necessary, clean or repair tractor sockets.

**Checking trailer connections:**

- each time before connecting the trailer to the tractor or connecting a second trailer.

5.3.7 REPLACING PNEUMATIC LINES

Permanently deformed, cut or frayed pneumatic lines qualify only for replacement.

The scope of service activities

- ➔ Completely reduce system pressure.
 - ⇒ Pressure reduction can be achieved by repeating the drain valve stem.
- ➔ Remove the pneumatic conduit by unscrewing the nut (2).

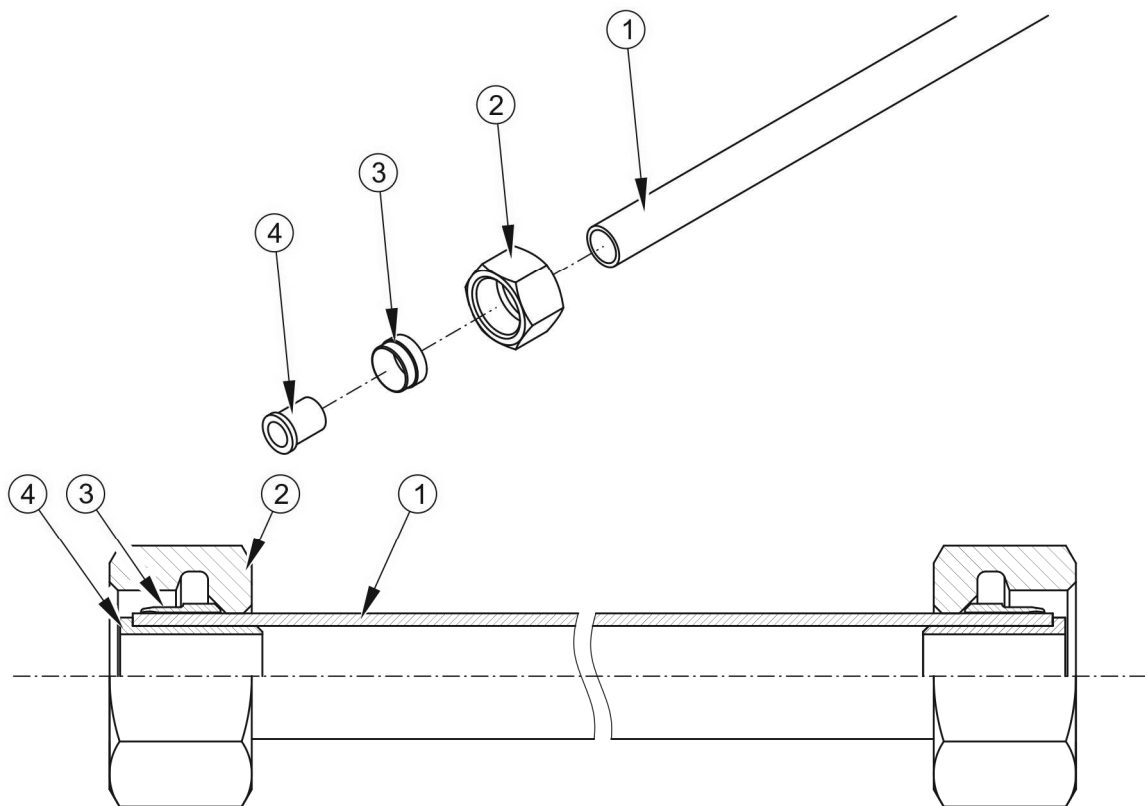

Figure 5.10 Pneumatic conduit installation

(1) pneumatic conduit, (2) connection nut, (3) cutting ring, (4) reinforcing sleeve

- ➔ Insert new cable.
 - ⇒ The inside of the pneumatic conduit should be clean.
 - ⇒ The ends of the pneumatic conduit (1) must be cut at right angles.
 - ⇒ The cutting ring (3) should be fitted as on drawing (5.10).
 - ⇒ The reinforcing sleeve (4) of the conduit must be pressed in thoroughly.

- ➔ Check connections tightness according to chapter (5.3.2).

5.4 HYDRAULIC SYSTEM SERVICE

5.4.1 BASIC INFORMATION

Work related to the repair, replacement or regeneration of hydraulic system components (tipping cylinders, valves, etc.) should be entrusted to specialized workshops that have the appropriate technologies and qualifications to perform this type of work.

The user's obligations related to the operation of the hydraulic system only include:

- checking system tightness and visual inspection of the system,
- checking the technical condition of the hydraulic connectors.

ATTENTION



Use hydraulic oil recommended by the manufacturer. Never mix two types of oil.

The condition of the hydraulic system should be inspected on a regular basis during trailer use.

DANGER



It is forbidden to work with a defective hydraulic system of the front tilting extension.

It is forbidden to work with a defective hydraulic system of the steering lock.

It is forbidden to work with a defective hydraulic system of the tailgate.

It is forbidden to work with a defective hydraulic system of the floor conveyor.

The hydraulic system is under high pressure during operation

5.4.2 HYDRAULIC SYSTEM TIGHTNESS CONTROL

The scope of service activities

- ➔ Hitch the trailer to the tractor.
- ➔ Connect all hydraulic and pneumatic system lines according to the instructions in the operating manual.

- ➔ Clean connectors and cylinders.
- ➔ Open and close the tailgate several times.
 - ⇒ When the cylinder piston rod is fully extended, check the cylinder bore for signs of seizing and deep scratches.
- ➔ Start the floor conveyor mechanism - check the smoothness of the chain movement.
- ➔ Perform a reversing maneuver and observe the hydraulic steering lock system operation.
 - ⇒ Help from another person is required.
- ➔ Open and close the front tilting extension several times.
 - ⇒ When the cylinder piston rod is fully extended, check the cylinder bore for signs of seizing and deep scratches.
- ➔ Check hydraulic cylinders and hydraulic lines for leaks.

In the event of oiling on hydraulic cylinder bodies, the nature of the leakage must be checked. When the actuator is fully extended, check the seal locations. Small leaks are permissible with symptoms of "sweating", however in the event of noticing leaks in the form of "droplets", stop using the trailer until the fault is removed. If a malfunction has appeared in the brake cylinders, it is forbidden to drive the trailer with the damaged installation until the defect is removed.

**Checking for leaks:**

- after the first week of use,
- every 12 months of use.

5.4.3 CONTROL OF TECHNICAL CONDITION OF HYDRAULIC CONNECTORS AND SOCKETS

The hydraulic connectors and sockets of the trailer and tractor must be technically sound and kept clean. Tractor and trailer hydraulic systems are sensitive to the presence of solid impurities, which may cause damage to precise components of the installation (impurities may cause jamming of hydraulic valves, scratches on cylinder surfaces, etc.)

	<p>Checking the hydraulic connectors and sockets:</p> <ul style="list-style-type: none"> • Each time before connecting the trailer to the tractor.
---	--

5.4.4 HYDRAULIC HOSES REPLACEMENT

Rubber hydraulic hoses should be replaced every 4 years regardless of their technical condition. This operation should be entrusted to specialized workshops.

	<p>Replacement of hydraulic hoses:</p> <ul style="list-style-type: none"> • every 4 years.
---	--

5.5 SUSPENSION SERVICE

Table 5.2 Mechanical suspension service schedule

INSPECTION INTERVAL	SERVICE ACTIVITIES
<p>After the first ride with a load. Before intensive use or once every 6 months.</p>	<p>Tighten all "U" bolt nuts on the axle to the recommended tightening torque - figure (5.11) pos. A. Tighten the nuts diagonally.</p>
	<p>Tighten all screw connections of the bolts in the suspension pos. B and item D (spring clamps, brackets, rigid and adjustable reaction rods, springs) - figure (5.11).</p>
	<p>Tighten the fastening of the adjustable reaction rods - figure (5.11) pos. C. If the screws are loose, the length of the rods may not be correct. Check that the axles are correctly aligned after tightening the screws (middle section with left- and right-hand thread).</p>
	<p>Tighten the elastic sleeves of the rigid and adjustable reaction rods. Pressure pads (pos. 1) should not touch the support (pos. 2). If they are in contact, replace the rubber conical sleeves (item 3) - figure (5.12). The rubber sleeves should be lubricated before assembly.</p>
<p>Once a year</p>	<p>Check the condition of the springs (item 5): clean thoroughly and brush the sides of the springs to check for cracks.</p>

INSPECTION INTERVAL	SERVICE ACTIVITIES
	If there is clearance between the springs and the axle, check the entire mounting system: U-bolts, and guide plates and clamping plates of the spring bolts.

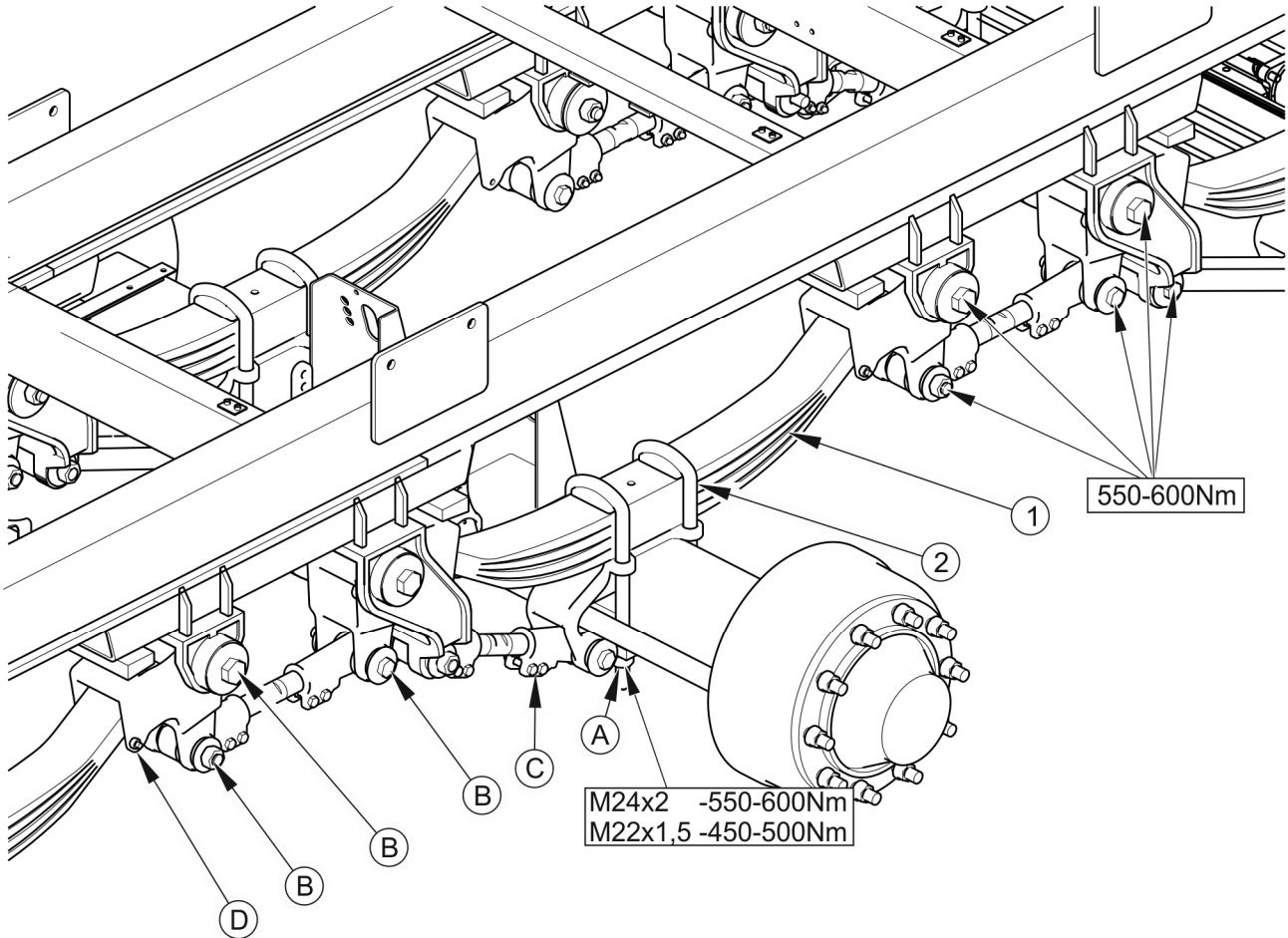



Figure 5.11 Mechanical suspension maintenance

(1) spring, (2) „U” bolt, (A) U bolt nuts, (B) suspension screw connections, (C) reaction rods fastening, (D) spring clamps



In the event of severe conditions of use or heavy use, maintenance should be carried out more often.

Servicing the hydraulic suspension system includes checking for leaks and regularly tightening all screw connections. In the event of an oil leak on hydraulic hose connections, tighten the connector, if this does not remove the fault - replace the hose or connector parts

with new ones. If oil leaks outside the connector, the leaking system line must be replaced. Any mechanical damage requires replacement of the subassembly with a new one. In case of damage to the hydraulic cylinders, they must be replaced or repaired.

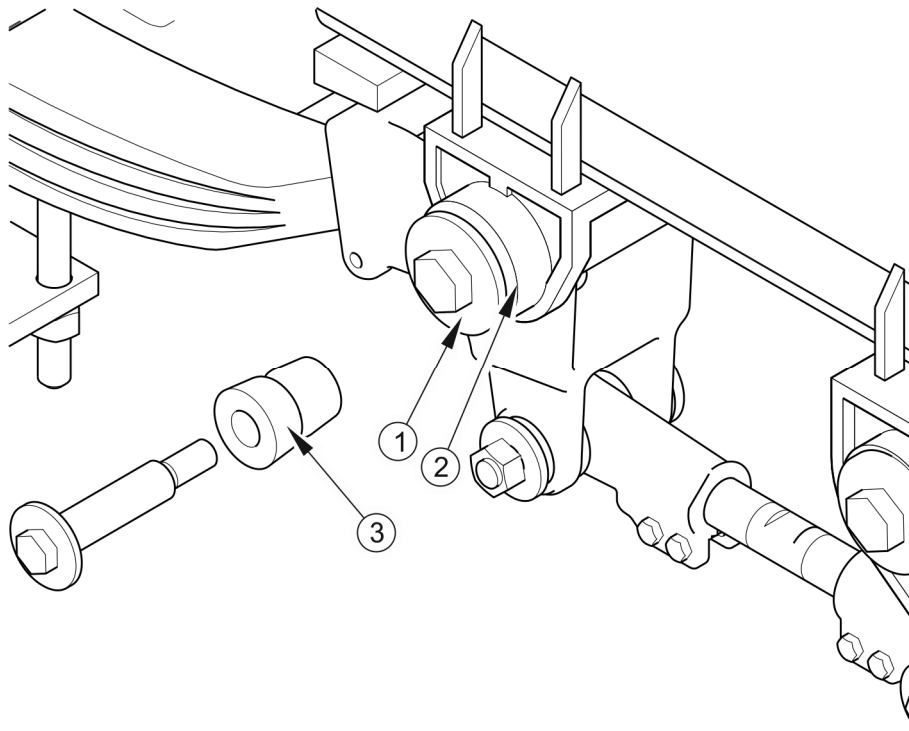

Figure 5.12 Rubber sleeves maintenance

(1) Pressure pad, (2) bracket, (3) rubber sleeve



ATTENTION

Trailer suspension bolt connections should be tightened under load.

5.6 ELECTRICAL INSTALATION AND WARNING COMPONENTS SERVICE

5.6.1 BASIC INFORMATION

Work related to the repair, replacement or regeneration of electrical installation components should be entrusted to specialized workshops that have the appropriate technologies and qualifications to perform this type of work.

The user's obligations only include:

- technical inspection of the electrical installation and reflectors,
- changing light bulbs.

**TIP**

Before traveling, make sure that all lamps and reflectors are clean.

The scope of service activities

- ➔ Connect the trailer to the tractor with appropriate connection cable.
 - ⇒ Ensure that the connection cable is in working order. Check the connection sockets on the tractor and on the trailer.
- ➔ Check completeness, technical condition and correct functioning of trailer lighting.

**ATTENTION**

Driving with defective lighting installations is prohibited. Damaged lampshades and burned out bulbs should be replaced immediately before driving. Lost or damaged reflectors should be replaced with new ones.

- ➔ Check the completeness of all reflectors.
- ➔ Check the correct installation of the triangular plate holder for slow moving vehicles.
- ➔ Before traveling on a public road, make sure that the tractor has a reflective warning triangle (SMV plate).

**Checking the electrical installation:**

- each time when connecting the trailer.

5.6.2 LIGHT BULBS REPLACEMENT

Light bulb list is presented in table (5.3). All lampshades of lighting lamps are mounted with screws and there is no need to disassemble the entire lamp or trailer components.

Table 5.3 Light bulb list

LIGHT BULB	LAMP TYPE	LIGHT BULB / QUANTITY IN ONE LAMP	LAMP QUANTITY
Rear left grouped lamp	WE 549L	R10W / 1 pcs. P21W / 2 pcs.	1
Rear right grouped lamp	WE 549P	R10W / 1 pcs. P21W / 2 pcs.	1
Front position lamp	LO-110PP	C5W / 1 pcs.	2
End-outline lamp	127 021 00 00	R5W / 1 pcs.	2

5.7 LUBRICATION

The trailer should be lubricated with a hand or foot grease gun, filled with the recommended lubricant. If possible, remove old grease and other contaminants before starting work. After finishing work, wipe off excess grease.

Parts that should be lubricated using machine oil should be wiped with a dry clean cloth, and then the lubricated surfaces oiled with a small amount of oil (with oiler or brush). Wipe off excess oil.

The replacement of grease in wheel axle hub bearings should be entrusted to specialized service points equipped with the appropriate tools. In accordance with the recommendations of the axle manufacturer, disassemble the entire hub, remove the bearings and individual sealing rings. After thorough cleaning and inspection, install lubricated components. If necessary, bearings and seals should be replaced. Lubrication of axle bearings should be carried out at least once every 2 years or after covering 50,000 km. In the event of intensive use, this should be done more often.

Empty containers after grease or oil should be disposed of in accordance with the lubricant manufacturer's instructions.

Table 5.4 Lubrication schedule

LP.	LUBRICATION POINTS	QUANTITY	GREASE TYPE	INTERVAL
1	<i>Hub bearings</i>	4	A	24M
2	<i>Towing eye</i>	1	B	14D
3	<i>Front extension hinges</i>	2	A	12M
4	<i>Tailgate pins</i>	2	A	3M
5	<i>Tailgate cylinders bearings</i>	4	B	3M
6	<i>Mechanical suspension</i>	1	A	6M
7	<i>Rear coupling</i>	1	B	1M
8	<i>Parking brake mechanism</i>	1	A	6M
9	<i>Floor conveyor front wheel</i>	4	B	14D
10	<i>Floor conveyor rear bearing casing</i>	4	B	14D
11	<i>Expander shaft sleeves</i>	8	A	3M
12	<i>Expander arm</i>	4	A	3M
13	<i>Steering lock cylinder eyelet</i>	2	A	3M
14	<i>Spring sliding surface</i>	8	B	6M
15	<i>Suspension spring</i>	4	B	6M
16	<i>Axle pivot pin</i>	2	B	3M

LP.	LUBRICATION POINTS	QUANTITY	GREASE TYPE	INTERVAL
17	<i>Coupler eyelet</i>	2	A	3M
18	<i>PTO shaft socket</i>	1	A	6M
19	<i>Tailgate cylinder eyelet</i>	1	A	3M
20	<i>Articulated shaft joints</i>	8	A	50H
21	<i>Dosing drums drive chain</i>	2	B	30H
22	<i>Chain tensioner sleeve</i>	2	A	3M

Lubrication intervals – M month, D – day, H - hour

Recommended lubricants:

A – general purpose machine grease (lithium, calcium),

B – permanent grease for heavily loaded elements with addition of MoS₂ or graphite

C – ordinary machine oil, silicon spray lubricant

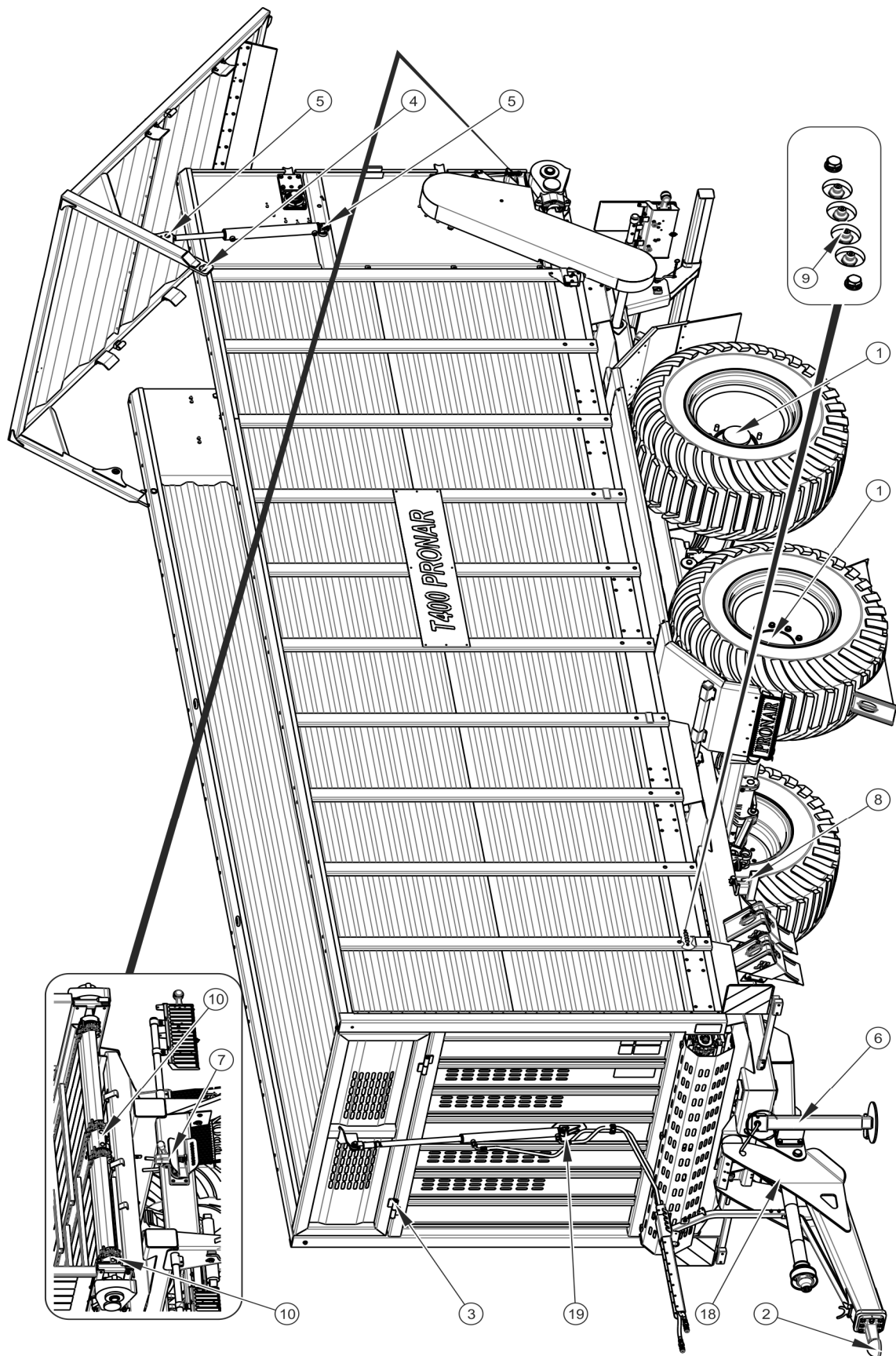

Figure 5.13 Greasing points

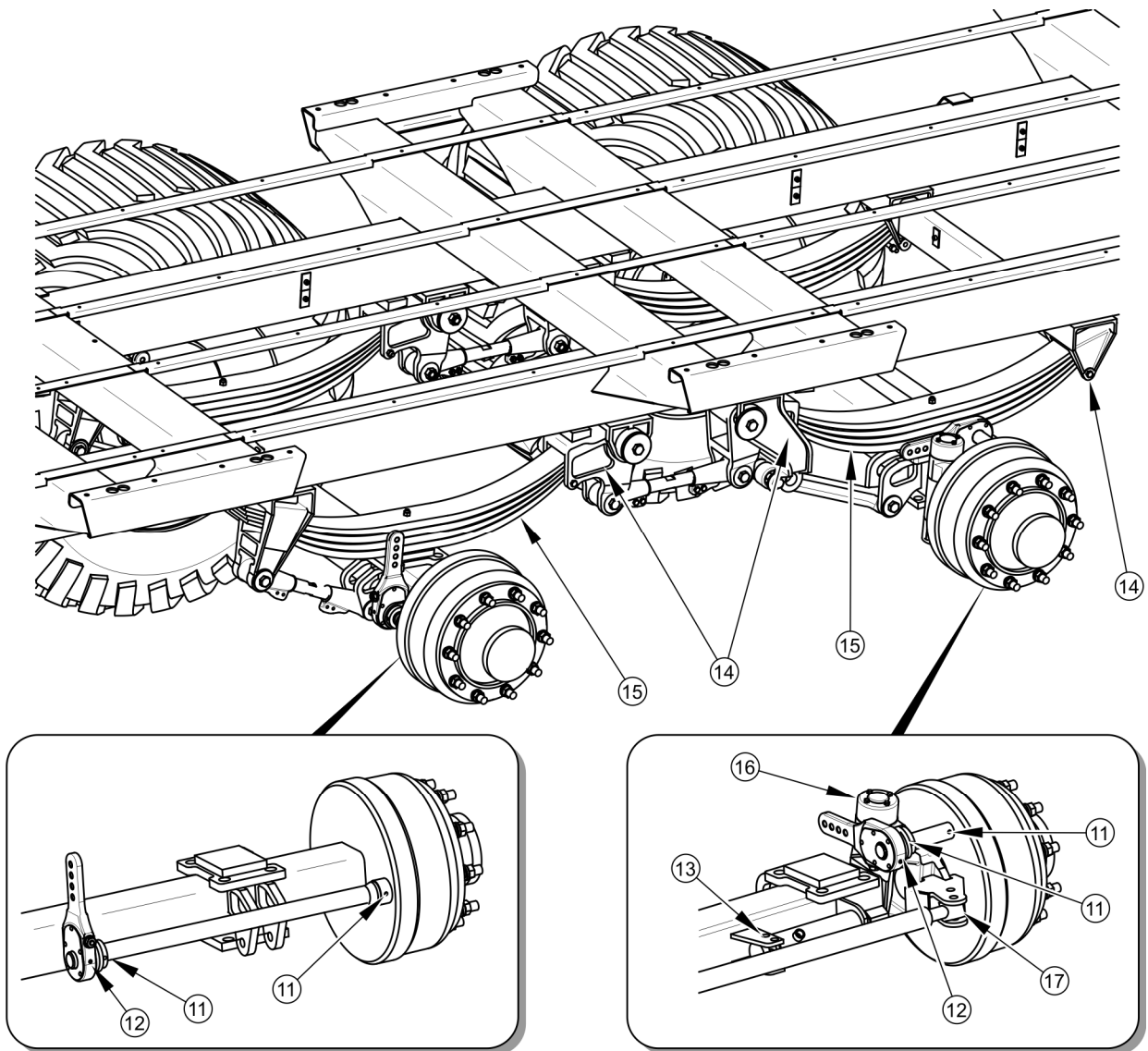

Figure 5.14 Greasing points - suspension

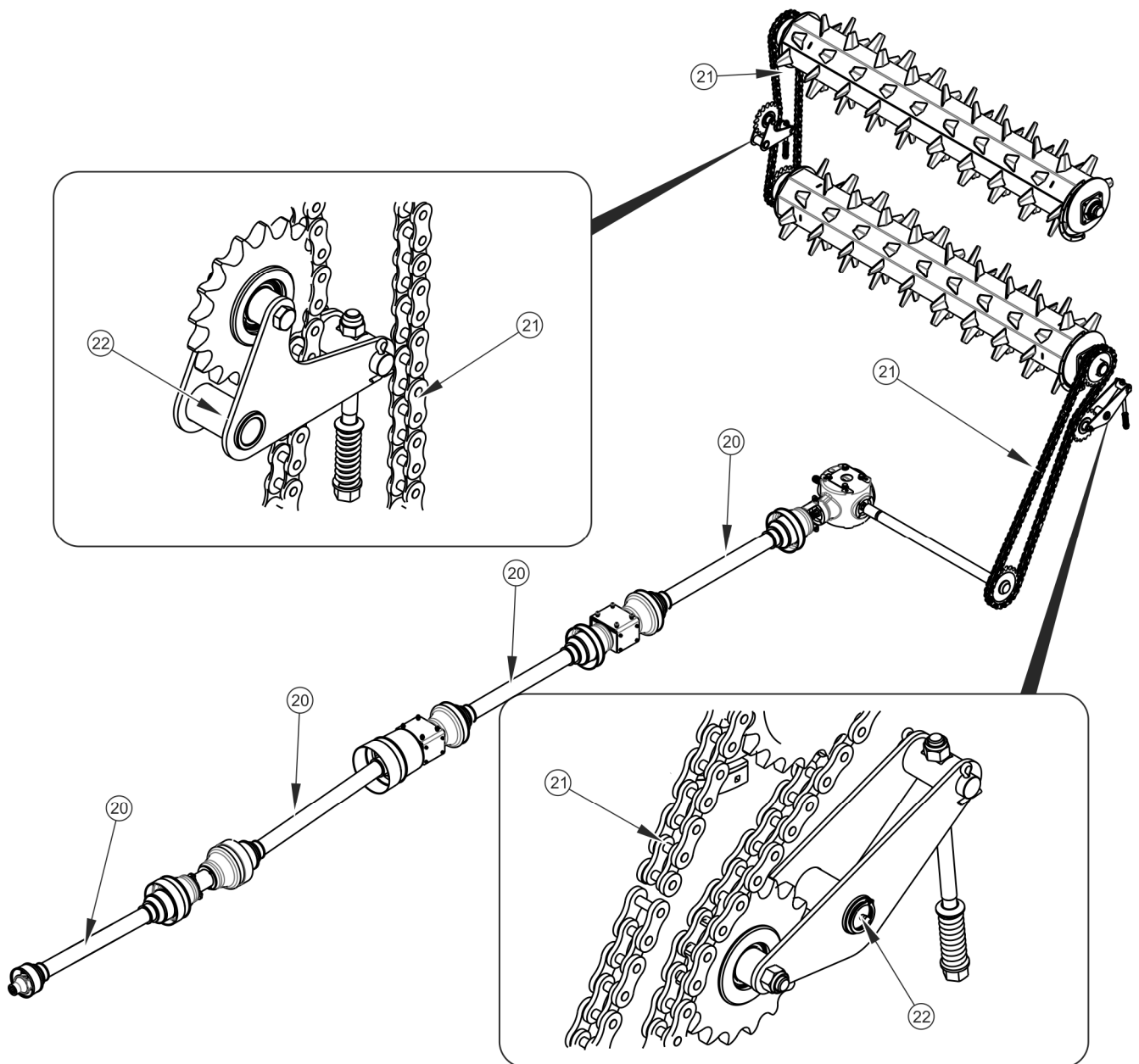

Figure 5.15 Greasing points – power transmission, dosing drums

5.8 CONSUMABLES

5.8.1 HYDRAULIC OIL

It is absolutely necessary to comply with the principle that the oil in the trailer hydraulic system and in the tractor hydraulic system should be of the same grade. If different types of oil are used, make sure that both hydraulic means can be mixed together. Using different

types of oil may cause damage to the trailer or agricultural tractor. The new machine is filled with L HL32 Lotos hydraulic oil.

Table 5.5 Hydraulic oil characteristic - L-HL 32 Lotos

NO.	DESCRIPTION	UNIT	VALUE
1	<i>Viscosity classification according to ISO 3448VG</i>	-	32
2	<i>Kinematic viscosity in 40⁰C</i>	<i>mm²/s</i>	28.8 – 35.2
3	<i>Grade classification according to ISO 6743/99</i>	-	HL
4	<i>Grade classification according to DIN 51502</i>	-	HL
5	<i>Flash-point</i>	C	230

If it is necessary to change the hydraulic oil, read the oil manufacturer's instructions carefully. If he recommends flushing the system with an appropriate preparation, follow these recommendations. It is important to ensure that chemicals used for this purpose do not act aggressively on the materials of the hydraulic system. During normal operation of the trailer, it is not necessary to change the hydraulic oil, however, if necessary, this operation should be entrusted to specialist service points.

The oil used, due to its composition, is not classified as a dangerous substance, however long-term effects on the skin or eyes may cause irritation. In the event of contact of oil with skin, wash the place of contact with water and soap. Do not use organic solvents (gasoline, kerosene). Soiled clothing should be removed to prevent oil from getting on skin. If the oil gets into eyes, flush them with large amount of water and in case of irritation contact your doctor. Hydraulic oil under normal conditions is not harmful to the respiratory tract. The hazard only occurs when the oil is strongly atomized (oil mist), or in the event of a fire during which toxic compounds may be released. Oil should be quenched with carbon dioxide, foam or extinguishing steam. Do not use water to extinguish the fire.

5.8.2 LUBRICANTS

For heavily loaded parts it is recommended to use lithium grease with the addition of molybdenum disulphide (MOS₂) or graphite. For less loaded components, it is recommended to use general purpose machine greases that contain anti-corrosive additives and are highly resistant to water washout. Aerosol preparations (silicone greases, anti-corrosive lubricants) should have similar properties.

Before using lubricants, read the information leaflet for the selected product. Particularly important are safety rules and how to handle a given lubricant and how to dispose of waste (used containers, contaminated rags, etc.). The information leaflet (product card) should be kept together with the grease.

5.9 TRAILER CLEANING

The trailer should be cleaned depending on demand and before a longer standstill (e.g. before winter). The use of a pressure washer obliges the user to become familiar with the principle of operation and recommendations for the safe operation of this device.

Guidelines for cleaning the trailer

- Before washing the trailer, open all walls and extensions. Thoroughly clean the load box from cargo residues (sweep or blow with compressed air), especially around walls and extensions.
- To clean the trailer, use only clean tap water or water with a cleaning detergent additive with a neutral pH.
- The use of pressure washers increases the washing efficiency, but be careful when working. During washing, the nozzle of the cleaning aggregate must not be closer than 50 cm to the surface being cleaned.
- The water temperature should not exceed 55 °C.
- Do not direct the water jet directly at the elements of the installation and equipment of the trailer, i.e. control valve, braking force regulator, brake cylinders, hydraulic cylinders, pneumatic, electric and hydraulic plugs, lights, electrical connectors, information and warning stickers, statutory plate, cable connectors, trailer lubrication points, etc. High pressure water jet may cause mechanical damage to these components.
- For cleaning and maintenance of plastic surfaces, it is recommended to use clean water or special preparations intended for this purpose.
- Do not use organic solvents, preparations of unknown origin or other substances that may damage the painted, rubber or plastic surface. It is recommended to carry out the test on a not visible surface in case of doubt.

- Oily or greasy surfaces should be cleaned with extraction naphtha or degreasing agents, and then washed with clean water and detergent. Follow the cleaning agent manufacturer's instructions.
- Washing detergents should be stored in their original containers, or alternatively, replacement containers, but very clearly marked. The preparations cannot be stored in containers intended for storing food and beverages.



DANGER

Read the instructions for use of cleaning detergents and preservatives.

When washing with detergents, wear suitable protective clothing and eye protection.

- Ensure cleanliness of flexible hoses and sleeves. The materials from which these elements are made may be susceptible to organic substances and some detergents. As a result of long-term effects of various substances, the aging process is accelerated and the risk of damage increases. Elements made of rubber are recommended to be maintained with the help of specialized preparations after thorough washing.
- After washing, wait for the trailer to dry and then grease all control points as recommended. Wipe off excess grease or oil with a dry cloth.
- Respect environmental protection principles, wash trailer in designated places.
- Washing and drying the trailer must take place at an ambient temperature above 0 °C.
- After washing and drying the trailer, lubricate all control points, regardless of the period of the last treatment.

5.10 STORAGE

- It is recommended to store the trailer indoors or under a roof.
- If the machine will not be used for a long period of time, it must be protected against the effects of weather conditions, especially those which cause corrosion

of steel and accelerate the aging of the tires. The machine must be unloaded during storage time. The trailer should be washed and dried very thoroughly.

- Corroded areas should be cleaned of rust, degreased and protected with a primer paint and then painted with a topcoat according to the color scheme.
- In the event of a longer downtime, it is necessary to grease all components regardless of the period of the last treatment.
- Rims and tires should be carefully washed and dried. During longer storage of unused trailer, it is recommended to move the machine once every 2-3 weeks so that the place of contact of the tire with the ground is in a different position. The tires will not deform and will maintain proper geometry. Tire pressure should be checked from time to time and, if necessary, the tires inflated to the correct value.

5.11 FLOOR CONVEYOR CHAINS TENSION REGULATION

The tension of the floor conveyor chains must be checked every day, especially during the initial period of operation. The tension is checked visually by observing the arrangement of the chains on the trailer slides, checking the tension force. If there is hopping of links on the drive sprocket of the conveyor mechanism during operation of the chains, tension of both chains should be adjusted. The tensioning force for each of the chains is 200kg.

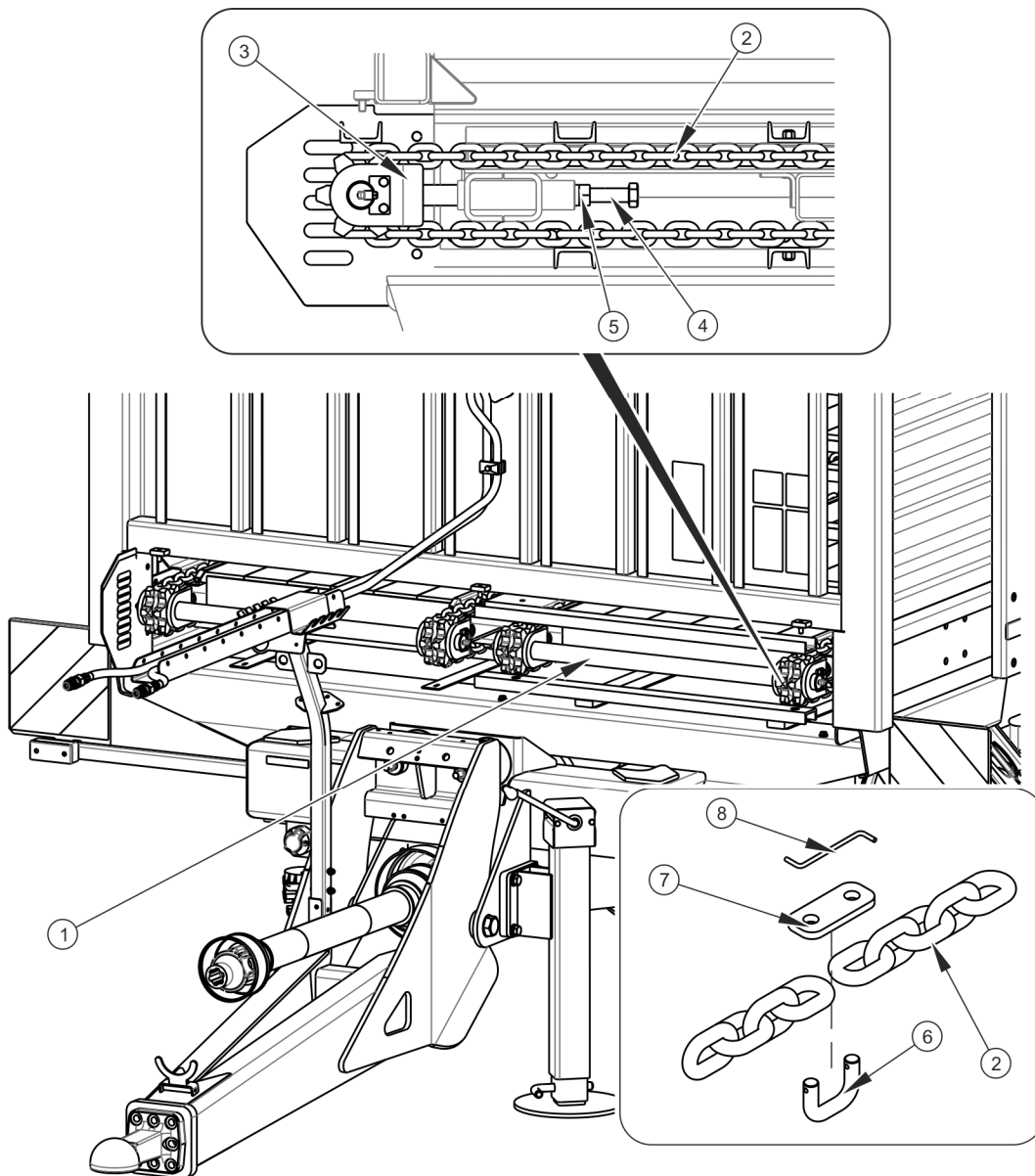

Figure 5.16 Floor conveyor mechanism

(1) Floor conveyor mechanism, (2) conveyor chain, (3) drive mechanism, (4) tensioning screw, (5) locking nut, (6) closing link, (7) closing plate, (8) clip

If the chain tensioning force is insufficient and adjustment by means of a screw is no longer possible, the chain should be shortened by two links so that the chain can be closed again with the closing link (6).

Chain tension adjustment

- Stop the vehicle, then switch off tractor engine, immobilize the trailer with parking brake. Place chocks under the rigid axle wheel,

- ➔ Loosen the locking nut (5) - fig. (5.16),
- ➔ Tighten the chain (2) with the screw (4),
 - ⇒ If the value of the chain tension force is adequate, lock the screw (4) with the nut (5).
 - ⇒ If the required chain tension has not been obtained, loosen the screw (4), then unfasten the chain in the place where it is connected with the closing link (6),
 - ⇒ Shorten the chain by two links, install the link (6), then the plate (7) and the clip (8),
 - ⇒ Tighten the chain with the screw (4),
- ➔ Repeat for the other cooperating chain.
- ➔ Check if the chains have been closed properly and the level of their tension.

ATTENTION



Before making adjustments, switch off the drive of the machine and secure the tractor cab against unauthorized access.

If the chain adjustment range with tensioning screws (4) is insufficient, drive chains should be shortened.

Adjust the tension and length of drive chains in pairs.

TIP



The tension force of each chain is 200kg. Each of the conveyor chains must be tensioned with equal force.

When shortening the chain, it is recommended to replace the clip (8) with a new one - figure (5.16).

5.12 CHAIN TRANSMISSION SERVICE

If the chain gears are noisy, adjust the tension of the chains on both sides of the dosing drums under the side covers. Loud operation is a symptom of too much clearance, which

increases with the working time. Chain elongation which is the reason for this behavior is normal.

To adjust the tension of the drive chain it is necessary to:

- ➔ Disconnect PTO shaft from the tractor,
- ➔ Open transmission covers at the rear of the trailer's load box,
- ➔ Check chain clearance,
 - ⇒ The correct chain clearance measured in the middle of the working part should be in the range from 5 to 15 mm,
- ➔ Use the screw (3) and nut (4) to set the tensioner (2) in such a position that the chain is properly tensioned,
 - ⇒ If the chain tension cannot be adjusted (stretched chain), replace it with a new one,
- ➔ After checking and making adjustments, the chain should be lubricated and gearboxes secured with a guard.



DANGER

Before making adjustments, switch off the machine drive and secure the tractor cabin against unauthorized access.

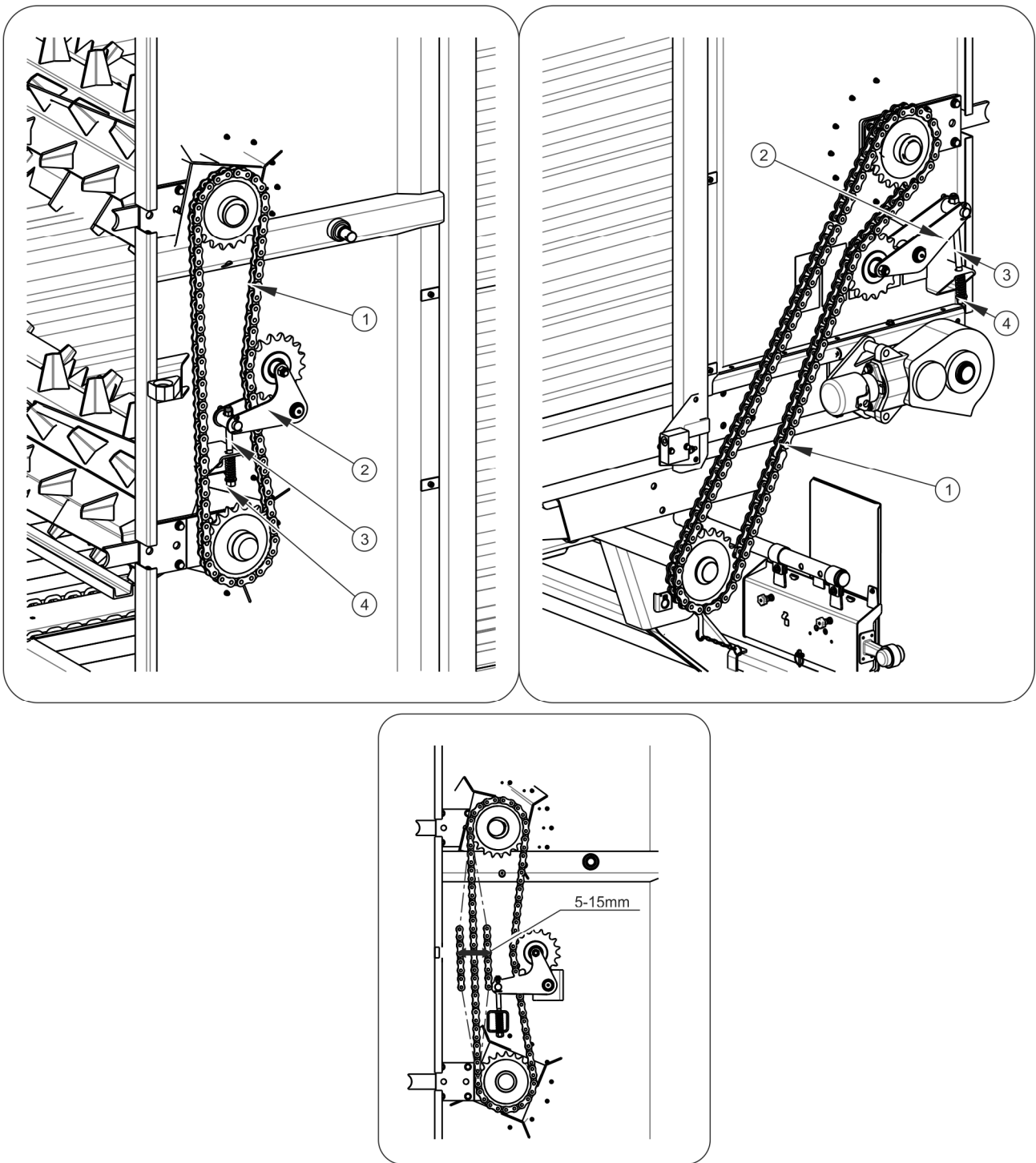

Figure 5.17 Chain transmission adjustment

(1) chain (2) tensioner, (3) screw, (4) nut

5.13 TRANSMISSION SERVICE

All Pronar T400 trailer gears are filled with SAE 90 EP gear oil (API GL-5 SAE 80W / 90).

Table 5.6 T400 trailer gears

GEAR POSITION AND NUMBER	LUBRICANT TYPE	OIL AMOUNT
Power transmission mechanism 118-02.011.L	SAE 90 EP (API GL-5 SAE 80W/90)	2.5L
Conveyor mechanism RT200 catalogue number 9358		2.5L

Signs such as fresh oil stains and increased transmission noise may indicate that the oil level is too low.



The oil level in the gears of the conveyor mechanism should be checked through transparent sight glasses before each start of the machine.

Changing the oil should be carried out at the oil working temperature, when the machine is running for a few minutes, then any impurities that are in the gearbox will mix with the oil and then be drained with it.



Used hydraulic oil in gearboxes should be changed after the first 50 hours of operation, subsequent changes should be made every 500 hours.



DANGER

During work related to oil control and oil change, use appropriate personal protective equipment, i.e. protective clothing, footwear, gloves, glasses. Avoid oil contact with skin.

5.14 TIGHTENING TORQUE OF BOLT CONNECTIONS

Table 5.7 Tightening torque of bolt connections

METRIC THREAD	5.8(1)	8.8(1)	10.9(1)
	Md [Nm]		
M10	37	49	72
M12	64	85	125
M14	100	135	200
M16	160	210	310
M20	300	425	610
M24	530	730	1 050
M27	820	1 150	1 650
M30	1 050	1 450	2 100

(1) – strength class according to DIN ISO 898

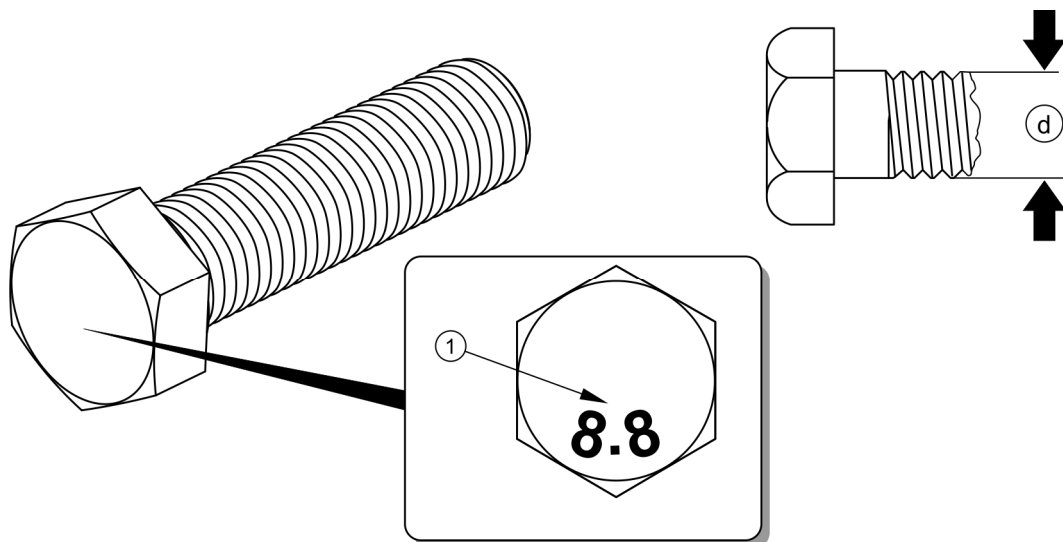



Figure 5.18 Screw with metric thread

(1) strength class, (d) thread diameter

During maintenance and repair work, apply appropriate tightening torques to screw connections, unless other tightening parameters are given. The recommended tightening

torques for the most common bolted connections are shown in the table below. The given values apply to non-lubricated steel bolts.



TIP

The hydraulic hoses should be tightened with a torque of 50 - 70 Nm.

5.15 TROUBLESHOOTING

Table 5.8 **Faults and their removal methods**

<i>FAULT</i>	<i>CAUSE</i>	<i>REMOVAL METHOD</i>
<i>Trouble with driving off</i>	<i>Pneumatic braking system lines are not connected</i>	<i>Connect the brake lines.</i>
	<i>Pneumatic system connection lines are damaged</i>	<i>Replace the cables with new ones.</i>
	<i>Connection leaks</i>	<i>Tighten, replace seals or sealing sets.</i>
	<i>The trailer is braked with parking brake</i>	<i>Release the parking brake.</i>
	<i>Control valve or relay valve is defective</i>	<i>Check the valves. In the event of damage to any of the elements, repair or replace</i>
	<i>Pressure in the brake system is too low</i>	<i>Check the pressure on the pressure gauge of the tractor, wait for the compressor to fill the tank to the required pressure. Damaged tractor air compressor. Repair or replace. Damaged tractor pressure regulator. Repair or replace. System leakage.</i>
<i>Noise in the hub of the driving axle</i>	<i>Excessive bearings clearance</i>	<i>Check clearance and adjust if necessary.</i>

FAULT	CAUSE	REMOVAL METHOD
	<i>Damaged bearings</i>	<i>Replace the bearings together with the sealing rings.</i>
<i>Excessive heating of the axle hub</i>	<i>Service brake is incorrectly adjusted</i>	<i>Adjust expander arm positions.</i>
	<i>Worn brake linings</i>	<i>Replace brake shoes.</i>
<i>The front wall does not rise</i>	<i>Incorrectly connected hydraulic system lines</i>	<i>Check and correct if necessary.</i>
	<i>Hydraulic system hose quick couplings are damaged</i>	<i>Replace the quick couplings.</i>
	<i>Incorrect hydraulic oil viscosity</i>	<i>Check the oil quality, make sure that the oils in both machines are of the same grade. If necessary, change the oil in the tractor and / or trailer.</i>
	<i>Insufficient tractor hydraulic pump yield, tractor hydraulic pump defective</i>	<i>Check the hydraulic pump of the tractor.</i>
	<i>Damaged or dirty actuator</i>	<i>Check the cylinder piston rod (bending, corrosion), check the cylinder for leaks (piston rod seal), repair or replace the cylinder if necessary.</i>
<i>Jerking, uneven braking of the trailer</i>	<i>Incorrectly adjusted brakes</i>	<i>Adjust the brakes.</i>
	<i>Worn brake linings</i>	<i>Replace the linings with new ones.</i>
<i>Conveyor chains knocking</i>	<i>Excessive extension of the conveyor chains. Incorrect adjustment of conveyor chain tension.</i>	<i>Check chain tension and adjust according to section 5.11</i>
<i>Jamming of the dosing drums</i>	<i>Too high speed of floor conveyor.</i>	<i>Reduce conveyor speed and change direction.</i>

FAULT	CAUSE	REMOVAL METHOD
	<i>Tailgate closed or not open sufficiently</i>	<i>Check the correct opening of the tailgate.</i>
	<i>Damaged chain transmission or insufficient chain tension. Tensioner springs damaged.</i>	<i>Open the covers and check the condition and tension of the transmission chains.</i>
<i>Damage to the PTO shaft</i>	<i>Too large angular deflection during operation.</i>	<i>Use a wide-angle shaft or disconnect the PTO when cornering.</i>
	<i>PTO shaft too short or too long</i>	<i>Change the PTO shaft. Adjust the shaft according to the instructions in the manual provided by the shaft manufacturer</i>
<i>Chain conveyor control does not work</i>	<i>Oil flow interrupted.</i>	<i>Check the degree of wear of the connector plug. Set the tractor's control valve to pressure.</i>
	<i>Mixed-up supply hoses</i>	<i>Correct the connection.</i>

NOTES

A series of horizontal dotted lines for writing notes.



ANNEX A

Tires dimension range

TRAILER TYPE	FRONT AXLE / REAR AXLE
T400	550/60 – 22.5 171 A8 ⁽¹⁾ 600/55 – 22.5 16P R ⁽²⁾ 700/50 – 26.5 174 A8 ⁽³⁾

⁽¹⁾ – disc wheel 16x22.5" ET=0

⁽²⁾ - disc wheel 16x22.5" ET=-20

⁽³⁾ - disc wheel 24x26.5 ET=-50

