Thank you for purchasing our trailer. In the interests of your safety and care for the reliability and durability of the machine, we ask that you familiarise yourself with the content of this manual.

Remember!!!

Before using the trailer for the first time, check if the wheels are properly tightened!!! Regularly check the technical condition of the machine in accordance with the attached schedule.

INTRODUCTION

Information contained herein is current at date of publication. As a result of improvements, some numerical values and illustrations contained in this publication may not correspond to the factual specification of the machine supplied to the user. The manufacturer reserves the right to introduce design changes in machines produced that facilitate operation and improve the quality of their work, without making minor amendments to this Operator's Manual. Please send your comments and proposals on the design and operation of the machine to the Manufacturer. This information enables objective evaluation of the machines produced and provides indications for their further improvement. Information on significant design changes is passed on to users on information inserts attached to this Operator's Manual (annexes). This Operator's Manual is an integral part of the machine's documentation. Before using the machine, the user must carefully read this Operator's Manual and observe all recommendations. This guarantees safe operation and ensures malfunction free work of the machine. The machine is designed to meet obligatory standards, documents and legal regulations currently in force.

The Operator's Manual describes the basic principles of safety in use and operation of the Pronar T046 agricultural trailer. If the information contained in the Operator's Manual needs clarification then the user should refer for assistance to the sale point where the machine was purchased or to the Manufacturer.

MANUFACTURER'S ADDRESS:

PRONAR Sp. z o.o.

ul. Mickiewicza 101A

17-210 Narew

CONTACT TELEPHONES

+48 085 681 63 29

+48 085 681 64 29

+48 085 681 63 81

+48 085 681 63 82

Information, descriptions of danger and precautions and also recommendations and prohibitions associated with user safety instructions are marked:



and also preceded by the word "**DANGER**". Failure to observe the instructions may endanger the machine operator's or other person's health or life.

Particularly important information and instructions, the observance of which is essential, are distinguished in the text by the sign:



and also preceded by the word "**ATTENTION**". Failure to observe the instructions may lead to damage to the machine as a result of improper operation, adjustment or use.

In order to focus the user's attention on the need to perform maintenance, the relevant section of the Operator's Manual is marked with the pictogram:



DIRECTIONS USED IN THIS OPERATOR'S MANUAL

Left side – side to the left hand of the operator facing in the direction of machine's forward travel.

Right side – side to the right hand of the operator facing in the direction of machine's forward travel.

REQUIRED SERVICE ACTIONS

Service actions described in the manual are marked: ➡

Result of service/adjustment actions or comments concerning the performance of actions are marked: ⇨



PRONAR Sp. z o.o.

ul. Mickiewicza 101 A

17-210 Narew, Polska

tel./fax (+48 85) 681 63 29, 681 63 81, 681 63 82,
681 63 84, 681 64 29

fax (+48 85) 681 63 83

http://www.pronar.pl

e-mail: pronar@pronar.pl

EC DECLARATION OF CONFORMITY OF THE MACHINERY

PRONAR Sp. z o.o. declares with full responsibility, that the machine:

Description and identification of the machinery	
Generic denomination and function:	TRAILER
Type:	T046
Model:	-----
Serial number:	
Commercial name:	TRAILER PRONAR T046

to which this declaration relates, fulfills all the relevant provisions of the Directive **2006/42/EC** of The European Parliament and of The Council of 17 May 2006 on machinery, and amending Directive 95/16/EC (Official Journal of the EU, L 157/24 of 09.06.2006).

The person authorized to compile the technical file is the Head of Research and Development Department at PRONAR Sp. z o.o., 17-210 Narew, ul. Mickiewicza 101A, Poland.

This declaration relates exclusively to the machinery in the state in which it was placed on the market, and excludes components which are added and/or operations carried out subsequently by the final user.

Narew, the _____

Place and date

Z-CA DYREKTORA
d/s technicznych
członek zarządu

Roman Orłowski

*Full name of the empowered person
position, signature*

TABLE OF CONTENTS

1 BASIC INFORMATION	1.1
1.1 IDENTIFICATION	1.2
1.1.1 TRAILER IDENTIFICATION	1.2
1.1.2 AXLE IDENTIFICATION	1.3
1.1.3 LIST OF SERIAL NUMBERS	1.4
1.2 PROPER USE	1.5
1.3 EQUIPMENT	1.8
1.4 TERMS & CONDITIONS OF WARRANTY	1.8
1.5 TRANSPORT	1.10
1.5.1 TRANSPORT ON VEHICLE	1.10
1.5.2 INDEPENDENT TRANSPORT BY THE USER	1.11
1.6 ENVIRONMENTAL HAZARDS	1.12
1.7 WITHDRAWAL FROM USE	1.13
2 SAFETY ADVICE	2.1
2.1 BASIC SAFETY RULES	2.2
2.1.1 BASIC SAFETY RULES	2.2
2.1.2 HITCHING AND UNHITCHING FROM TRACTOR	2.3
2.1.3 HYDRAULIC AND PNEUMATIC SYSTEM	2.4
2.1.4 LOADING AND UNLOADING OF ANIMALS	2.4
2.1.5 CLEANING, MAINTENANCE AND ADJUSTMENT	2.5
2.1.6 SAFE DRIVING	2.8
2.1.7 TYRES	2.10
2.1.8 DESCRIPTION OF RESIDUAL RISK	2.10
2.2 INFORMATION AND WARNING DECALS	2.11

3	DESIGN AND OPERATION	3.1
3.1	TECHNICAL SPECIFICATION	3.2
3.2	TRAILER CONSTRUCTION	3.3
3.2.1	CHASSIS	3.3
3.2.2	LOAD BOX	3.4
3.2.3	FRAME WITH TARPAULIN COVER	3.8
3.2.4	ELECTRICAL SYSTEM	3.8
3.2.5	MAIN BRAKE	3.11
3.2.6	PARKING BRAKE	3.16
4	CORRECT USE	4.1
4.1	PREPARING THE TRAILER FOR WORK	4.2
4.1.1	PRELIMINARY INFORMATION	4.2
4.1.2	HAND-OVER AND INSPECTION OF THE MACHINE AFTER DELIVERY	4.2
4.1.3	PREPARING THE TRAILER FOR THE FIRST USE, TEST RUN OF THE TRAILER	4.3
4.1.4	PREPARING THE TRAILER FOR NORMAL USE	4.4
4.2	HITCHING AND UNHITCHING THE TRAILER	4.5
4.3	LOADING AND UNLOADING ANIMALS	4.8
4.3.1	PREPARING THE TRAILER FOR WORK	4.8
4.3.2	LOADING AND UNLOADING	4.11
4.4	TRANSPORT OF ANIMALS	4.12
4.5	PROPER USE AND MAINTENANCE OF TYRES	4.14
5	MAINTENANCE	5.1
5.1	PRELIMINARY INFORMATION	5.2
5.2	SERVICING WHEEL AXLE	5.2
5.2.1	PRELIMINARY INFORMATION	5.2
5.2.2	CHECK WHEEL AXLE BEARINGS FOR SLACKNESS	5.3
5.2.3	ADJUSTMENT OF PLAY OF WHEEL AXLE BEARINGS	5.5

5.2.4	MOUNTING AND DISMOUNTING WHEEL, INSPECTION OF WHEEL NUT TIGHTENING.	5.6
5.2.5	CHECKING AIR PRESSURE, EVALUATING THE TECHNICAL CONDITION OF TYRES AND STEEL RIMS	5.8
5.2.6	MECHANICAL BRAKES ADJUSTMENT	5.9
5.2.7	CHANGE OF PARKING BRAKE CABLE AND ADJUSTMENT OF CABLE TENSION.	5.11
5.3	PNEUMATIC SYSTEM MAINTENANCE	5.13
5.3.1	PRELIMINARY INFORMATION	5.13
5.3.2	CHECKING AIR TIGHTNESS AND VISUAL INSPECTION OF PNEUMATIC SYSTEM	5.14
5.3.3	CLEANING THE AIR FILTERS	5.15
5.3.4	DRAINING WATER FROM AIR TANK	5.17
5.3.5	CLEANING DRAIN VALVE	5.18
5.3.6	CLEANING AND MAINTAINING PNEUMATIC LINE CONNECTIONS AND PNEUMATIC SOCKETS	5.18
5.4	HYDRAULIC SYSTEM MAINTENANCE	5.19
5.4.1	PRELIMINARY INFORMATION	5.19
5.4.2	CHECKING HYDRAULIC SYSTEM TIGHTNESS	5.19
5.4.3	CHECKING TECHNICAL CONDITION OF HYDRAULIC CONNECTIONS AND SOCKETS.	5.21
5.4.4	REPLACEMENT OF HYDRAULIC CONDUITS	5.21
5.5	TRAILER LUBRICATION	5.21
5.6	CONSUMABLES	5.24
5.6.1	HUDRAULIC OIL (HYDRAULIC BRAKE SYSTEM)	5.24
5.6.2	LUBRICANTS	5.25
5.7	TRAILER CLEANING	5.26
5.8	STORAGE	5.27
5.9	TIGHTENING TORQUE FOR NUT AND BOLT CONNECTIONS	5.28
5.10	TROUBLESHOOTING	5.29

SECTION

1

BASIC INFORMATION

1.1 IDENTIFICATION

1.1.1 TRAILER IDENTIFICATION

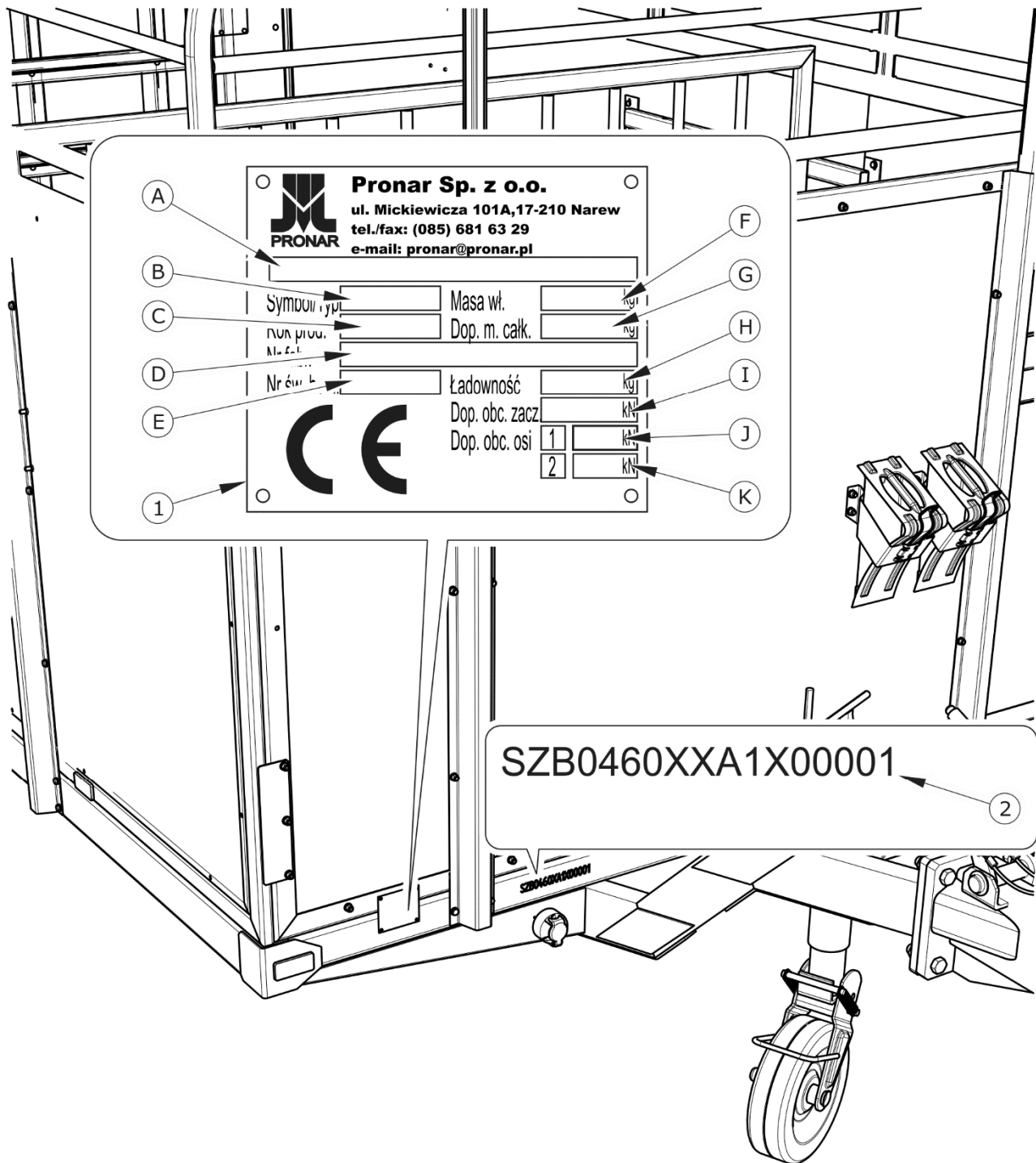

FIGURE 1.1 Location of the data plate and serial number

(1) data plate, (2) example of vehicle identification number

PRONAR T046 agricultural trailer is marked with the data plate (1) and with serial number (2). The serial number and data plate are located on the right side of the frame on the front beam - figure (1.1). When buying the machine check that the serial numbers on the machine agree with the number written in the *WARRANTY BOOK* and in the sales documents. The meanings of the individual fields found on the data plate are presented in the table below:

TABLE 1.1 Markings on data plate

ITEM	MARKING
A	General description and purpose
B	Symbol /Machine type
C	Year of manufacture
D	Seventeen digit vehicle identification number (VIN)
E	Official certificate number
F	Machine tare weight
G	Maximum gross weight
H	Carrying capacity
I	Permissible hitching system loading
J	Permissible front axle load
K	Permissible rear axle load (not applicable)

1.1.2 AXLE IDENTIFICATION

The serial number of the axle shaft and its type are stamped onto the data plate (1) secured to the axle shaft beam (2) – figure (1.2).

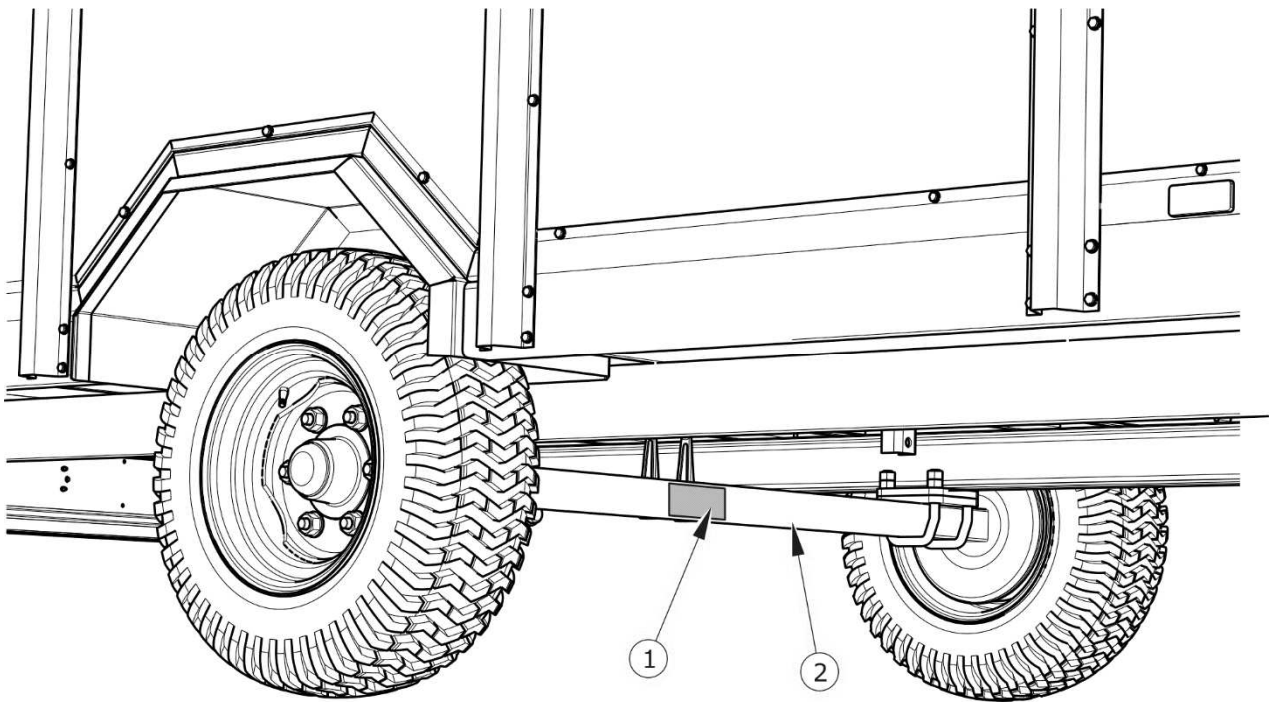

FIGURE 1.2 Location of the axle data plate

(1) data plate, (2) wheel axle,

1.1.3 LIST OF SERIAL NUMBERS

	<p>TIP</p> <p>In the event of ordering a replacement part or in the case of the appearance of problems it is often essential to give the serial number of the agricultural trailer or the serial number of the axle, therefore it is recommended that these numbers are inscribed in the table (1.2).</p>
---	--

TABLE 1.2 List of serial numbers

VIN														
S	Z	B	0	4	6	0	X	X			X			
AXLE SERIAL NUMBER														

1.2 PROPER USE

The T046 trailer is used by farmers to transport farm animals (e.g. to put them out to seasonal pasture), up to a distance of 50 km from the farm. The transport of animals should be compliant with *COUNCIL REGULATION (CE) NO. 1/2005 OF 22 DECEMBER 2004 ON THE PROTECTION OF ANIMALS DURING TRANSPORT AND RELATED OPERATIONS* and with directives *64/432/EEC* and *93/119/EC* and regulation *(CE) NO. 1255/97*.

The trailer is constructed according to current safety requirements and engineering standards. The brake system and the light and indicator system meet the requirements of road traffic regulations. The maximum speed of the trailer on public roads in Poland is 30 km/h (pursuant to Road Traffic Act *OF JUNE 20TH 1997, ART 20*). In the countries where the trailer is used, the limits stipulated by the road traffic legislation in force in a given country must be observed. The trailer speed must not, however, be greater than the maximum design speed of 30 km/h. Due to the specific nature of the transported load (livestock), Pronar T046 trailer is designed to:

- enable the transport of animals preventing their injuries or suffering and ensure the right safety level for animals;
- protect animals against weather conditions,
- facilitate cleanliness and disinfection of the load space,
- provide protections preventing animals from escaping or falling out,
- arrange animals, during transport, in an appropriate manner by means of a partition.

Using it as intended also involves the fulfilment of the general conditions of animal transport, namely:

- the transport of animals may not mutilate their bodies or make them suffer,
- the necessary steps must be taken to minimize the duration of the journey and the meet the needs of animals during transport,
- animals must be in a condition allowing them to travel

- staff dealing with animals should have adequate training or skills required and perform their duties without the use of violence or any methods likely to cause unnecessary fear, injury or suffering,
- transport must be carried out without delay to the destination and the welfare of animals must be inspected and maintained at an appropriate level

Using it as intended also involves all actions connected with the safe and proper operation and maintenance of the machine. Due to the above, the user is obliged to:

- carefully read the *OPERATOR'S MANUAL* of the trailer and the *WARRANTY BOOK* and conform with the recommendations contained in these documents,
- understand the trailer's operating principle and how to operate it safely and correctly,
- adhere to the established maintenance and adjustment plans,
- comply with general safety regulations while working,
- prevent accidents,
- comply with the road traffic regulations and transport regulations in force in a given country, in which the trailer is used,
- carefully read the Operator's Manual and comply with its recommendations,
- only hitch the trailer to an agricultural tractor, which fulfils all the requirements made by the trailer's Manufacturer.

The trailer may only be used by persons, who:

- are familiar with the contents of this publication and with the contents of the agricultural tractor Operator's Manual,
- have been trained in trailer operation and safe operation,
- have the required authorisation to drive and are familiar with the road traffic regulations and transport regulations.

TABLE 1.3 Agricultural tractor's requirements

CONTENTS	UNIT	REQUIREMENTS
Brake system connection sockets		
Single conduit pneumatic system	-	according to A DIN 74 294
Double conduit pneumatic system	-	according to ISO 1728
Hydraulic system	-	according to ISO 7421-1
Pressure rating of the system		
Single conduit pneumatic system	bar	5.8 - 6.5
Double conduit pneumatic system	bar	5.8
Hydraulic system	bar	150
Electrical system		
Electrical system voltage	V	12
Connection socket	-	7-pole compliant with ISO 1724
Tractor hitches		
Type of hitch		Transport hitches (upper or lower)
Minimum static vertical load capacity	kg	600
Other requirements		
Min. Tractor power	hp / /kW	28.6 / 21

The trailer may not be rented to other users for transporting animals. The trailer must not be used in any way other than that described above. Using it as intended also involves all actions connected with the safe and proper operation and maintenance of the machine. The trailer is not intended or designed for transporting people.

1.3 EQUIPMENT

TABLE 1.4 Trailer optional equipment

EQUIPMENT	STANDARD	ADDITIONAL	OPTION
<i>OPERATOR'S MANUAL, WARRANTY BOOK</i>	•		
Rotating drawbar eye Ø50	•		
Fixed drawbar eye Ø40			•
Ball drawbar eye Ø80			•
Wheel chocks	•		
Frame with tarpaulin cover	•		
Wooden floor	•		
Riffled plate floor			•
Riffled plate floor with bituminous screed			•
Internal partition		•	
Double conduit pneumatic brake system	•		
Single conduit pneumatic brake system			•
Hydraulic brake system			•
Overrun brake			•

Information concerning tires is provided at the end of this publication in *ANNEX A*.

1.4 TERMS & CONDITIONS OF WARRANTY

PRONAR Sp. z o.o. Narew guarantees the reliable operation of the machine when it is used according to its intended purpose as described in the *OPERATOR'S MANUAL*. The repair period is specified in the *WARRANTY BOOK*.

The warranty does not cover those parts and sub-assemblies of the machine which are subject to wear in normal usage conditions, regardless of the warranty period. Consumables include the following parts/sub-assemblies:

- drawbar hitching eye,
- pneumatic system connector filters,
- tyres,
- seals,
- bearings,
- components of wood or wood-based materials.

The warranty service only applies to factory defects and mechanical damage that is not due to the user's fault.

In the event of damage arising from:

- mechanical damage which is the user's fault, caused by road accidents,
- by inappropriate use, adjustment or maintenance, use of the trailer for purposes other than those for which it is intended,
- use of damaged machine,
- repairs carried out by unauthorised persons, improperly carried out repairs,
- making unauthorised alterations to machine design,

the user will lose the right to warranty service.

**TIP**

Demand that the seller carefully and precisely fills out the *WARRANTY BOOK* and warranty repair coupons. A missing date of purchase or sale point stamp, may make the user ineligible for any warranty repair or refund.

The user is obliged to report immediately on noticing any wear in the paint coating or traces of corrosion, and to have the faults rectified whether they are covered by the warranty or not. For detailed Terms & Conditions of Warranty, please refer to the *WARRANTY BOOK* attached to each machine.

Modification of the machine without the written consent of the Manufacturer is forbidden. In particular, do NOT weld, drill holes in, cut or heat the main structural elements of the machine, which have a direct impact on the machine operation safety.

1.5 TRANSPORT

The trailer is ready for sale completely assembled and does not require packing. Packing is only required for the machine's technical documentation and any extra fittings. The trailer is delivered to the user either transported on a vehicle or, after being attached to a tractor, independently (trailer towed with a tractor).

1.5.1 TRANSPORT ON VEHICLE

Loading and unloading of the agricultural trailer from vehicle shall be conducted using loading ramp with the aid of agricultural tractor, overhead crane or hoisting crane. During work adhere to the general principles of Health and Safety at Work applicable to reloading work. Persons operating reloading equipment must have the qualifications required to operate these machines.

Lifting equipment used for transporting the trailer must be attached only to the fixed structural elements of the machine. These elements are, first of all: frame, drawbar and axle.



IMPORTANT!

The trailer may not be attached or hitched by means of the drawbar eye, walls, tailgate or other structural components which are not strong enough to carry out such operations.

The trailer should be attached firmly to the platform of the vehicle using straps or chains fitted with a tightening mechanism. In order to attach the machine in a proper manner, fasten axles, frame longitudinal members and possibly drawbar. Additionally, support the drawbar with a wooden block of such a height that the trailer frame is positioned parallel to the load platform. Chocks, wooden blocks or other objects without sharp edges should be placed under the wheels of the trailer to prevent it from rolling. Wheel blocks must be nailed to the vehicle load platform planks or secured in another manner preventing their movement.

Use certified and technically reliable securing measures. Worn straps, cracked securing catches, bent or corroded hooks as well as other damage may disqualify use of the given

element from use. Carefully read the information stated in the Operator's Manual for the given securing measure. The number of securing elements (cables, straps, chains and stays etc.) and the force necessary for their tensioning depends on a number of things, including weight of the machine, the construction of vehicle carrying it, speed of travel and other conditions. For this reason it is impossible to define the securing plan precisely.

A correctly secured machine does not change its position with regard to the transporting vehicle. The securing elements must be selected according to the guidelines of the Manufacturer of these elements. In case of doubt apply a greater number of securing straps in order to immobilise the machine. If necessary, sharp edges of trailer should be protected at the same time protecting the securing straps from breaking during transport.



DANGER

Incorrect application of securing measures may cause an accident.

During reloading work, particular care should be taken not to damage parts of the machine's fittings or the paint coating. The tare weight of the agricultural trailer is given in table (3.1).



IMPORTANT!

When being road transported on a motor vehicle the trailer must be mounted on the vehicle's platform in accordance with the transport safety requirements and the regulations.

Driver of the vehicle should be particularly careful during travel. This is due to the vehicle's centre of gravity shifting upwards when loaded with the machine.

Use only certified and technically reliable securing measures. Carefully read the manufacturer's instructions for the securing measures.

1.5.2 INDEPENDENT TRANSPORT BY THE USER

In the event of independent transport by the user, carefully read *THE OPERATOR'S MANUAL* and follow its recommendations. Independent transport involves towing the machine with own agricultural tractor to destination. During transport adjust travel speed to the prevailing road conditions, but do not exceed the maximum design speed.

**IMPORTANT!**

When transporting independently, the user must carefully read this operator's manual and observe its recommendations.

1.6 ENVIRONMENTAL HAZARDS

A hydraulic oil leak constitutes a direct threat to the natural environment owing to its limited biodegradability. The negligible solubility of hydraulic oil in water does not cause extreme toxicity of organisms living in the aquatic environment. The formation of a film of oil on the water may be the direct cause of physical action on organism, perhaps causing change of oxygen values in the water because of lack of direct contact of air with the water. An oil leak into water reservoirs may however lead to a reduction of the oxygen content.

While carrying out maintenance and repair work, which involves the risk of an oil leak, this work should take place on an oil resistant floor or surface. In the event of oil leaking into the environment, first of all contain the source of the leak, and then collect the leaked oil using available means. Remaining oil should be collected using sorbents, or by mixing the oil with sand, sawdust or other absorbent materials. The oil pollution, once gathered up, should be kept in a sealed, marked, hydrocarbon resistant container. The container should be kept away from heat sources, flammable materials and food.

**DANGER**

Used hydraulic oil or gathered remains mixed with absorbent material should be stored in a precisely marked container. Do not use food packaging for this purpose.

Oil, which has been used up or is unsuitable for further use owing to a loss of its properties should be stored in its original packaging in the conditions described above. Waste oil should be taken to the appropriate facility dealing with the re-use of this type of waste. Waste code (L-HL 32 Lotos hydraulic oil): 13 01 10. Detailed information concerning hydraulic oil may be found on the product's Material Safety Data Sheet.

**TIP**

The hydraulic system of the trailer is filled with L-HL32 Lotos hydraulic oil.

**IMPORTANT!**

Waste oil should only be taken to the appropriate facility dealing with the re-use of this type of waste. Do NOT throw or pour oil into sewerage or water tanks.

1.7 WITHDRAWAL FROM USE

In the event of decision by the user to withdraw the trailer from use, comply with the regulations in force in the given country concerning withdrawal from use and recycling of machines withdrawn from use. Before dismantling, remove completely the oil from the hydraulic system (if the trailer has a hydraulic system).

**DANGER**

During dismantling, use the appropriate tools, equipment (overhead travelling crane, crane or hoist etc.) and use personal protection equipment, i.e. protective clothing, footwear, gloves and eye protection etc.

Avoid contact of skin with oil. Do not allow used hydraulic oil to spill.

Worn out or damaged parts that cannot be reclaimed should be taken to a collection point for recyclable raw materials. Hydraulic oil should be taken to the appropriate facility dealing with the re-use of this type of waste.

SECTION

2

**SAFETY
ADVICE**

2.1 BASIC SAFETY RULES

2.1.1 BASIC SAFETY RULES

- Before using the machine, the user should carefully read this Operator's Manual and observe all recommendations. Do NOT start the trailer without knowledge of its function.
- The user is obliged to acquaint himself with the construction, action and the principles of safe usage of the machine and the regulations concerning the protection of animals during transport.
- Before using the trailer always check the machine, whether it is properly prepared for work, especially in terms of safety.
- If the information stated in the Operator's Manual is difficult to understand, contact a seller, who runs an authorised technical service on behalf of the Manufacturer, or contact the Manufacturer directly.
- Careless and improper use and operation of the trailer and also non-observance of the recommendations contained in this Operator's Manual, endanger health and life third persons and/or machine operator and transported animals.
- Be aware of the existence of a residual risk, and for this reason the fundamental basis for using this machine should be the application of safety rules and sensible behaviour.
- The machine must never be used by persons who are not authorised to drive the agricultural tractors and not trained in the safety principles and use of the machine, including children and people under the influence of alcohol.
- The trailer must not be used for purposes other than those for which it is intended. Anyone who uses the machine other than the way intended takes full responsibility for himself for any consequences of this use. Use of the machine for purposes other than those for which it is intended by the Manufacturer may invalidate the warranty.
- Use close fitting protective clothing.

- Any modification to the trailer frees PRONAR Narew from any responsibility for damage or detriment to health which may arise as a result.
- Before using the machine always check its technical condition, and in particular: technical condition of the drawbar, systems, safety guards and air pressure in tyres.
- Coupling and uncoupling the trailer may only take place when the machine is immobilised by use of the parking brake.
- Before using the trailer, always ensure that all the safety guards are in good condition and in place. Damaged or incomplete sub-assemblies must be exchanged for original new ones.
- The user is obliged to acquaint himself with the principles of safe operation, adjustment methods and inspection points of the machine and with the risks resulting from operation and maintenance of the machine.
- People must not be carried on the machine.
- The trailer may be operated only by one person at a time.

2.1.2 HITCHING AND UNHITCHING FROM TRACTOR

- Be especially careful when hitching and unhitching the machine.
- While connecting the trailer to the tractor, use the appropriate hitch. After completing the hitching of the machines check the safety of the hitch Carefully read the tractor Operator's Manual. If the tractor is equipped with an automatic hitch, make certain that the coupling operation is completed.
- When hitching, there must be nobody between the tractor and the trailer.
- Do NOT hitch the trailer to tractor, if the tractor does not meet the requirements of the Manufacturer (minimum tractor power demand, wrong connection etc.) – compare table (1.3) *AGRICULTURAL TRACTOR REQUIREMENTS*. Before hitching the machine, make certain that oil in the external hydraulic system of tractor may be mixed with the hydraulic oil in the machine's hydraulic system.

- When connecting the hydraulic lines to the tractor, make sure that the tractor hydraulic system and trailer are not under pressure. If necessary reduce residual pressure in the system.
- Before hitching the trailer check that both machines are in good technical condition.
- The machine unhitched from tractor must be immobilised with parking brake. If the machine is positioned on a slope, it should be additionally secured against moving by placing chocks under the machine's wheels. Terminals of hydraulic, electrical and pneumatic conduits should be protected against contamination.

2.1.3 HYDRAULIC AND PNEUMATIC SYSTEM

- When operating, the hydraulic and pneumatic systems are under high pressure.
- Regularly check the condition of connections and conduits. The pneumatic and hydraulic systems may not have any leaks.
- Before proceeding to maintenance-repair work, make certain that the hydraulic system is not under pressure.
- Rubber hydraulic conduits must be replaced every 4 years regardless of their technical condition.
- Use the hydraulic oil recommended by the Manufacturer.
- After changing the hydraulic oil, the used oil should be properly disposed of. Used oil or oil which has lost its properties should be stored in original containers or replacement containers resistant to action of hydrocarbons. Replacement containers must be clearly marked and appropriately stored.
- Do not store hydraulic oil in packaging designed for storing food or foodstuffs.

2.1.4 LOADING AND UNLOADING OF ANIMALS

- During loading and unloading, the trailer must be hitched to the tractor.
- Loading and unloading work should be carried out by someone experienced in this type of work.
- Before lowering the tailgate, remove the triangular slow-moving vehicle sign.

- Animals must be positioned uniformly on the trailer on the whole surface of the trailer.
- Climbing on the trailer in order to introduce the animals can only be done when it is absolutely motionless and the tractor engine is switched off.
- Do not exceed the permissible load of the trailer.
- Be especially careful when loading the machine.
- The transported animals must be tethered.

2.1.5 CLEANING, MAINTENANCE AND ADJUSTMENT

- Maintenance and repair works may be performed after hitching the trailer to the tractor. In such a case, turn off the tractor engine, remove the key from the ignition and immobilise the tractor with parking brake. Ensure that unauthorised persons do not have access to the tractor cab. Protect the machine against rolling by placing blocking chocks under the wheels. When performing works that do not require hitching to tractor, position the trailer on level and hard surface, support it using a parking stand, immobilise the machine with parking brake and protect it against rolling by placing chocks under the wheels. Place of work should be dry, clean and well-lighted.
- Regularly check the condition of the bolt and nut connections.
- During the warranty period, any repairs may only be carried out by Warranty Service authorised by the manufacturer. After the expiry of the warranty period it is recommended that possible repairs to the machine be performed by specialised workshops.
- During work use the proper, close-fitting protective clothing, gloves, protective goggles and appropriate tools.
- In the event of any fault or damage whatsoever, do not use the machine until the fault has been corrected.
- Servicing and repair work should be carried out in line with the general principles of workplace health and safety. In the event of injury, the wound must be immediately cleaned and disinfected. In the event of more serious injuries, seek a doctor's advice.

- Service inspections should be carried out according to the frequency specified in this Operator's Manual.
- Welding works may be performed only by persons having appropriate authorisations for this type of works.
- Before welding or electrical work, the trailer should be disconnected from the power supply, if the machine is connected to the tractor (disconnect the tractor negative battery cable (-) or disconnect connection lead). The paint coating should be cleaned. Burning paint fumes are poisonous for people and animals. Welding work should be carried out in a well lit and well ventilated space.
- In order to reduce fire risks, clean the trailer removing carefully any remaining fodder or bedding before welding works. Be especially careful when welding and pay attention to flammable or fusible elements (hydraulic system conduits, electrical system leads and other structural elements made of plastics). If there is a risk that they will catch fire or be damaged, they should be removed or covered with non-flammable material before commencing welding work. Before beginning work, prepare a CO₂ or foam extinguisher.
- Check condition of machine hydraulic system regularly, oil leaks are not allowed.
- Before beginning repair works on hydraulic or pneumatic systems reduce oil or air pressure.
- In the event of work requiring the trailer to be raised, use properly certified hydraulic or mechanical lifts for this purpose. After lifting the machine, stable and durable supports must also be used. Do NOT carry out work under a machine, which has only been raised with the lift jack.
- The machine must not be supported using fragile elements (bricks or concrete blocks).
- After completing work associated with lubrication, remove excess oil or grease. The machine should be kept clean and tidy.
- The user must not repair by himself the hydraulic cylinders. In the event of damage to these elements, repair should be entrusted to authorised service point or replace elements with new parts.

- Do NOT make repairs to drawbar (straightening, repairing or welding). A damaged drawbar must be replaced.
- Do NOT install additional appliances or fittings not according to the specifications defined by the Manufacturer.
- The trailer may only be towed when axles and brake system are reliable.
- Regularly check technical condition and mounting of all guards and protective elements.
- Should it be necessary to change individual parts, use only original parts or those indicated by the Manufacturer. Non-adherence to these requirements may put the user and other people's health and life at risk, and also damage the machine.
- In the event of injuries being caused by pressurised hydraulic oil, contact a doctor immediately. Hydraulic oil may find its way under the skin and cause infections. In the event of contact of oil with eye, rinse with large quantity of water and in the event of the occurrence of irritation consult a doctor. In the event of contact of oil with skin wash the area of contact with water and soap. Do NOT apply organic solvents (petrol, kerosene).
- Regularly check the condition of the bolt and nut connections.
- The machine can only be stood on when it is absolutely motionless and the tractor engine is switched off.
- The trailer should be kept clean and tidy.

2.1.6 SAFE DRIVING

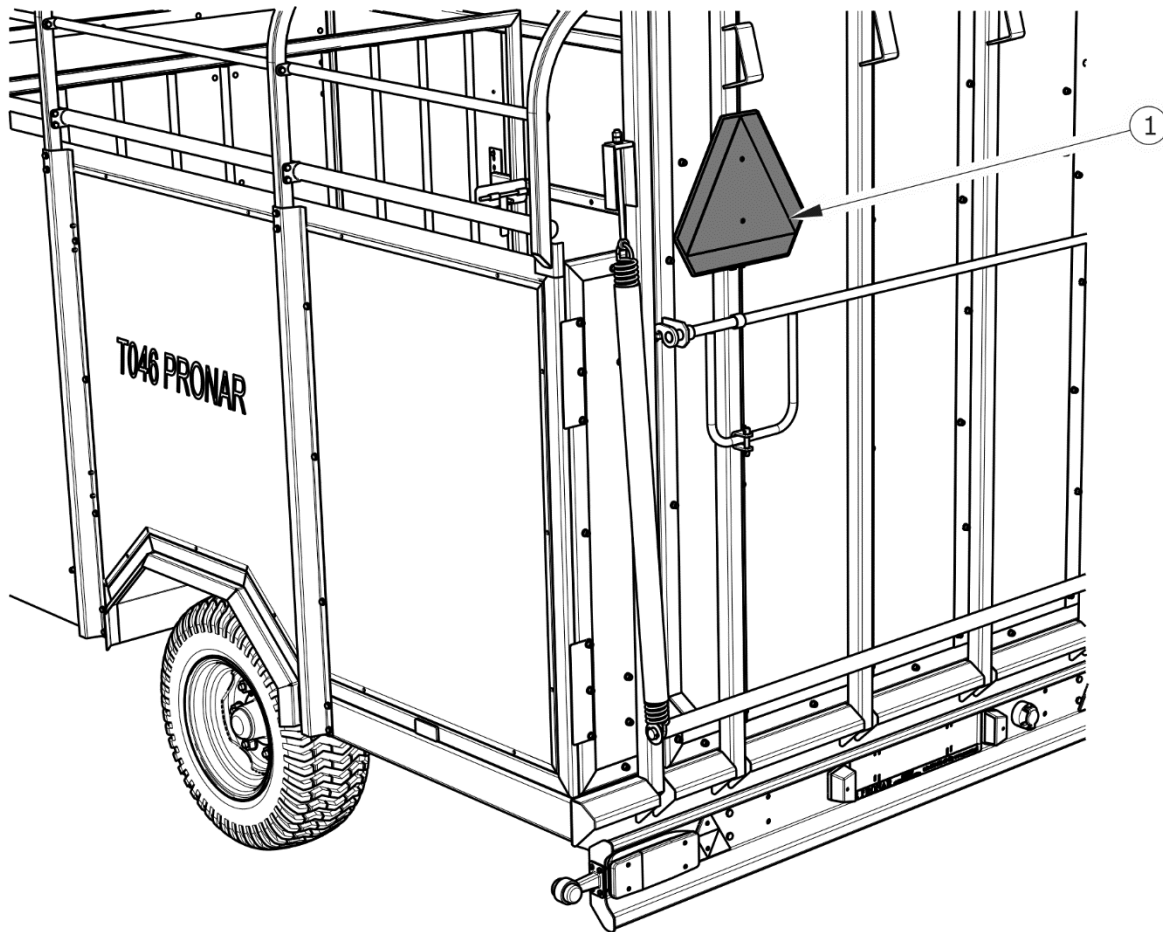

FIGURE 2.1 Mounting place for the slow-moving vehicle warning sign

(1) slow-moving vehicle warning sign

- If the trailer is the last vehicle in the group, a triangular slow-moving vehicle sign should be placed on the trailer's rear load box wall – see figure (2.1).
- When driving on public roads, comply with the road traffic regulations.
- During transport adjust travel speed to the prevailing road conditions. If possible avoid travelling on uneven terrain and unexpected corners.
- Do NOT exceed permissible travel speed. Excessive speed may lead to the loss of control of the set, damage to the trailer and/or tractor and lower breaking efficiency of the set.
- Before moving check that the slurry tanker is correctly hitched to the tractor (in particular check security of hitching pin).

- Vertical load borne by the trailer drawbar eye affects the steering of the agricultural tractor.
- The machine must NOT be left unsecured. The trailer unhitched from the tractor must be secured against rolling away by means of parking brake and wheel chocks placed under the wheel - figure (2.2). Chocks should be placed only under one wheel (one in front of the wheel, the second behind the wheel).

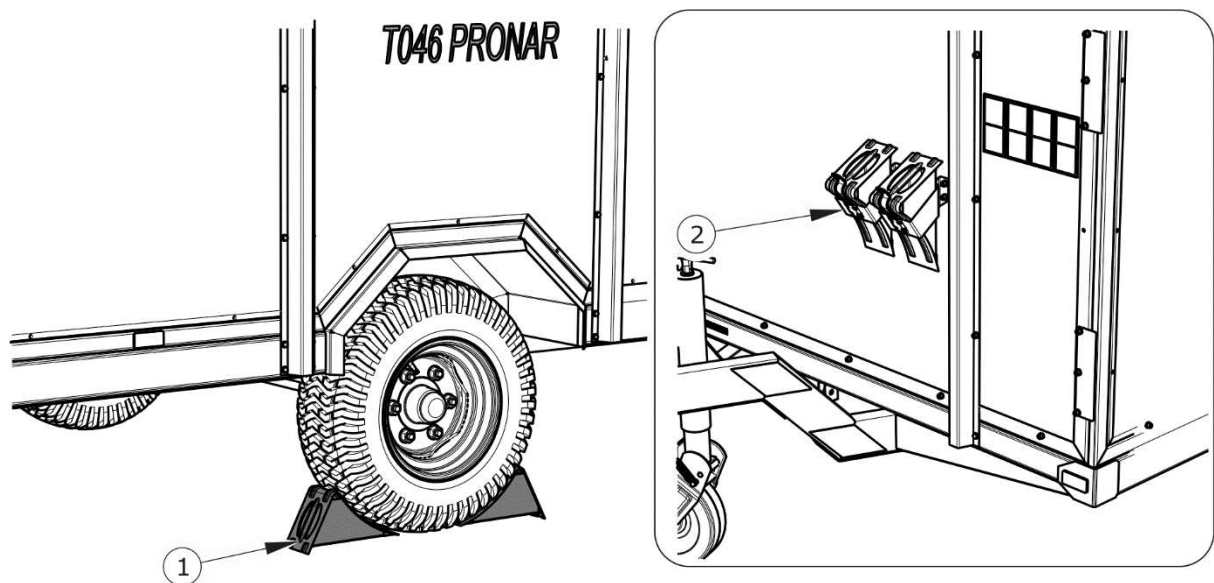

FIGURE 2.2 Method of placing chocks

(1) chock, (2) chock bracket

- Do NOT attempt to board trailer while travelling.
- Do NOT park trailer on slope.
- Before moving, check if the tailgate is closed properly.
- Before driving off check that the parking brake is released, the braking force regulator is positioned in the proper position (applies to pneumatic systems with a manual three position regulator).
- During reversing one should use the assistance of another person. During manoeuvring the person helping must stay at a safe distance from the danger zone and be visible all the time to the tractor driver.

- While driving on public roads the trailer must be fitted with a certified or authorised reflective warning triangle.
- Periodically drain water from the air tanks in pneumatic system. During frosts, freezing water may cause damage to pneumatic system components.
- Reckless driving and excessive speed may cause accidents.

2.1.7 TYRES

- When working with tyres, the trailer should be secured against rolling by placing chocks under the wheels. Wheels can be taken off the machine axle only when the machine is not loaded.
- Repair work on the wheels or tyres should be carried out by persons trained and entitled to do so. This work should be carried out using appropriate tools.
- Inspect the tightness of nuts in road wheels: after the first use of the trailer, after the first day of operation under load, after travelling 1,000 km and then every 6 months of use or travelling 25,000 km. The inspection should be repeated individually if a wheel has been removed from the wheel axle.
- Avoid potholes, sudden manoeuvres or high speeds when turning.
- Check the tyre pressure regularly. Pressure and tyres should be also checked during the whole day of intensive work. Please note that higher temperatures could raise tyre pressure by as much as 1 bar. At high temperatures and pressure, reduce load or speed. Do not release air from warm tyres to adjust the pressure or the tyres will be underinflated when temperatures return to normal.
- Protect tyre valves using suitable caps to avoid soiling.

2.1.8 DESCRIPTION OF RESIDUAL RISK

Pronar Sp. z o. o. in Narew has made every effort to eliminate the risk of accidents. There is, however, a certain residual risk, which could lead to an accident, and this is connected mainly with the actions described below:

- using the machine for purposes other than those for which it is intended,
- being between the tractor and the machine while the engine is running and when the machine is being hitched,

- being on the machine while the engine is running,
- operating the trailer with the safety guards removed or faulty,
- not maintaining safe distance while the slurry tanker is in operation,
- operation of the machine by persons under the influence of alcohol
- cleaning, maintenance and technical checks,
- work of machine on unstable and sloping surface,
- Loading and unloading animals.



The residual risk may be kept to a minimum by following the recommendations below:

- prudent and unhurried operation of the machine,
- sensibly adhere to the remarks and recommendations contained in the OPERATOR'S MANUAL,
- maintaining safe distance from the danger zone,
- a ban on being on the machine when it is operating, except the places specially designed for this purpose,
- carry out repairs and maintenance work in line with operating safety rules,
- using close fitting protective clothing,
- ensure unauthorised persons have no access to the machine, especially children.

2.2 INFORMATION AND WARNING DECALS

The trailer is labelled with the information and warning decals mentioned in table (2.1). Locations of pictograms on the machine are shown in figure (2.3). Throughout the time it is in use, the user of the trailer is obliged to take care that notices and warning and information symbols located on the machine are clear and legible. In the event of their destruction, they must be replaced with new ones. Information and warning decals may be purchased directly from the Manufacturer or your PRONAR dealer. New assemblies, changed during repair, must be labelled once again with the appropriate safety signs. During agricultural trailer cleaning do not use solvents which may damage the coating of information label stickers and do not subject them to strong water jets.

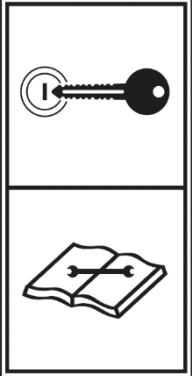
TABLE 2.1 Information and warning decals

ITEM	SAFETY SYMBOL	DESCRIPTION
1		<p>Caution! Before starting work, carefully read the Operator's Manual</p>
2		<p>Before beginning servicing or repairs, turn off engine and remove key from ignition</p>
3		<p>Before climbing on the ladder in order to perform maintenance or repair inside the tank, turn off engine and remove key from ignition. Secure tractor against unauthorised access.</p>
4	<p>T046 PRONAR</p>	<p>Machine type</p>
5		<p>Grease the machine according to the recommendations in the <i>OPERATOR'S MANUAL</i></p>

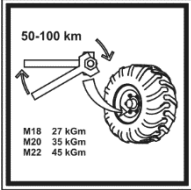
ITEM	SAFETY SYMBOL	DESCRIPTION
6		<p>Regularly check if the nuts and bolts fixing the wheels and other components are properly tightened.</p>

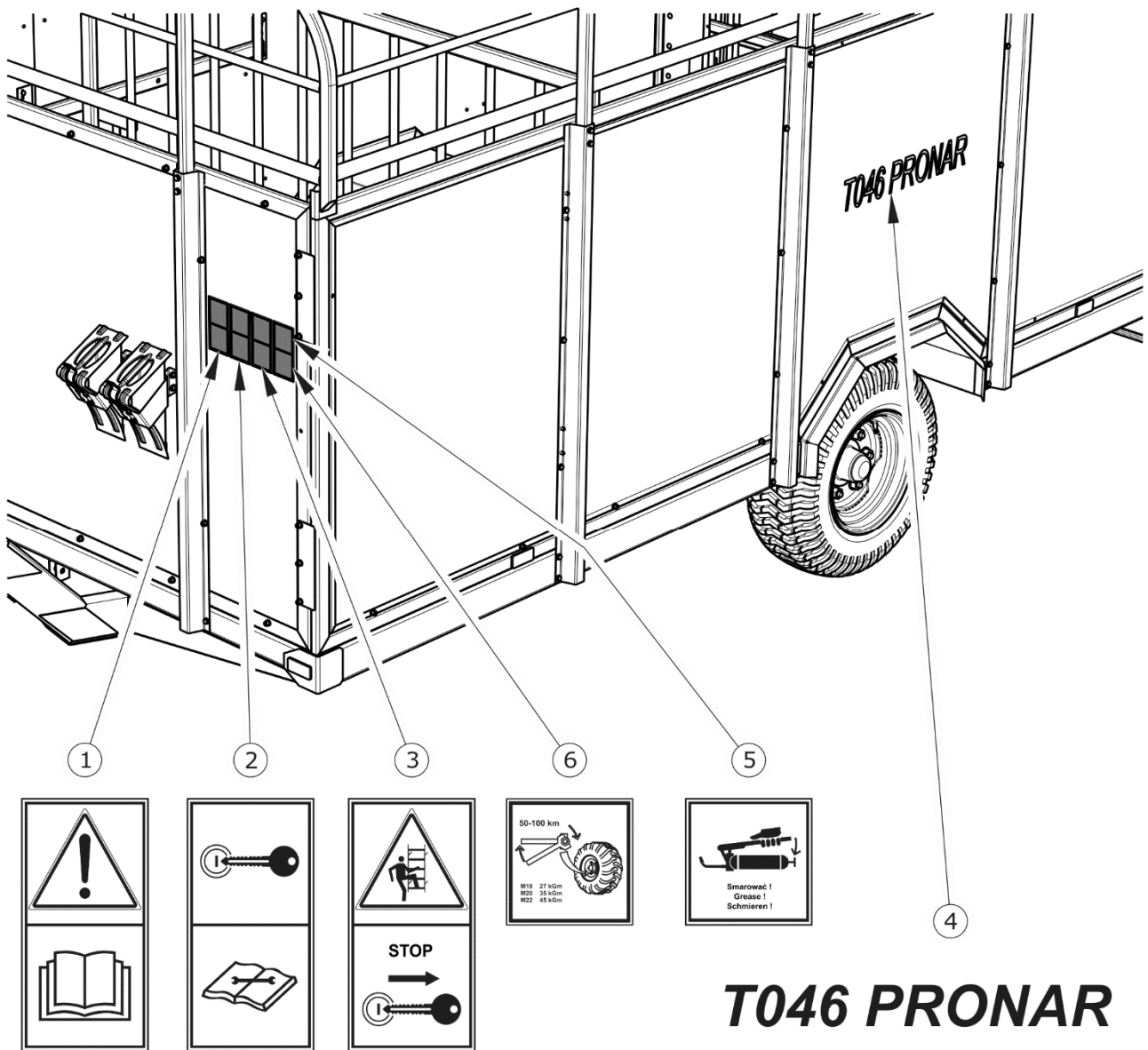

FIGURE 2.3 Locations of information and warning decals.

SECTION

3

**DESIGN
AND OPERATION**

3.1 TECHNICAL SPECIFICATION

TABLE 3.1 Basic technical data of the standard machine version

CONTENTS	UNIT	DATA
Dimensions		
Total length	mm	6,100
Total width	mm	2,515
Total height	mm	2,780
Load box dimensions:		
Length	mm	4,160
Width	mm	2,360
Height of load box walls	mm	1,350
Weight and carrying capacity		
Tare weight	kg	1,800
Gross weight	kg	5,500
Carrying capacity	kg	3,700
Other information		
Wheel track	mm	2,100
Height of platform from ground	mm	700
Tractor power demand	hp (kW)	28.6 (21)
Maximum design speed	km/h	30
Electrical system voltage	V	12
Drawbar load	kg	600
Sound power level	dB	below 70
Load surface	m ²	9.01

3.2 TRAILER CONSTRUCTION

3.2.1 CHASSIS

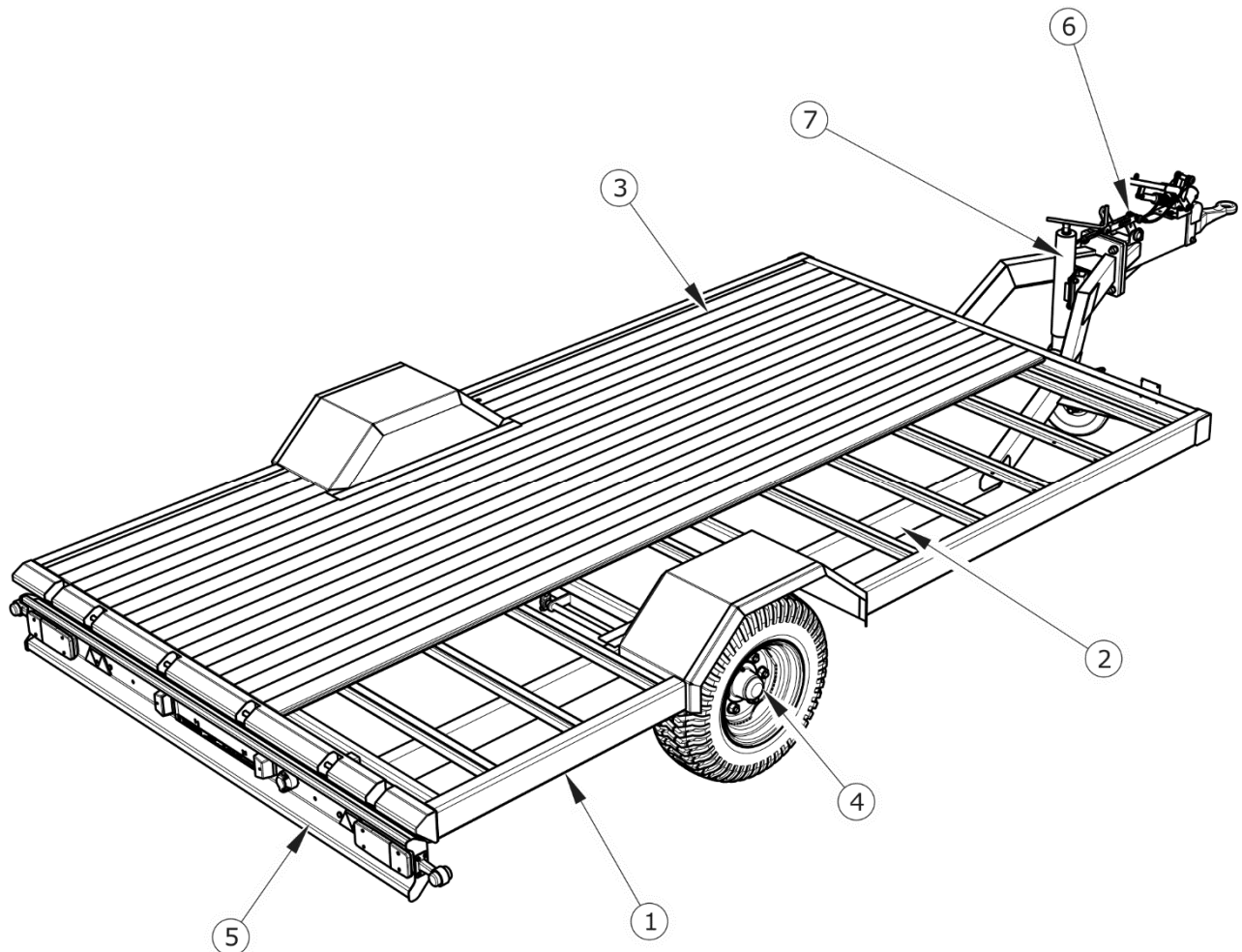

FIGURE 3.1 Chassis

(1) lower frame, (2) frame longitudinal member, (3) floor planks, (4) wheel axle, (5) lights support beam, (6) overrun drawbar, (7) support leg

Trailer chassis consists of subassemblies indicated on figure (3.1). The frame (1) is a structure welded from steel sections. The basic support component is formed by the longitudinal members (2) reinforced with crosspieces. The upper frame may be constructed in several variants:

- with a fixed drawbar to attach to the upper transport hitch of the tractor,

- with a fixed drawbar having a rotating or ball drawbar eye to attach to the lower hitch of the tractor,
- with an overrun drawbar to attach to the upper hitch of the tractor.

The upper part of the frame is a floor made of impregnated planks (3) – as standard, or a steel floor or a steel floor with bituminous screed as options.

The rear part of the frame contains components to fasten the wheel axle (4) plus components of the rear lighting assembly (5) – lights support beam. Wheel axle (4) consists of square bar terminated with a pin, on which wheel hubs are mounted on cone bearings. Hubs are fitted with brake shoes actuated by mechanical cam expanders. In the trailer variant with an overrun brake, the overrun-type axle is fitted with a mechanism protecting against wheels locking while reversing.

The front part of the frame contains the drawbar (6) and support leg (7). The used type of drawbar and drawbar eye depend on the trailer variant:

- an overrun drawbar with a fixed drawbar eye $\varnothing 40\text{mm}$ (DIN 74054) to attach to the upper transport hitch,
- a drawbar with a fixed drawbar eye $\varnothing 40\text{ mm}$ (DIN 74054) to attach to the upper transport hitch,
- a drawbar with a rotating eye $\varnothing 50\text{ mm}$ (DIN 9678) to attach to the lower transport hitches.

3.2.2 LOAD BOX

The load box has side walls (1) and a front wall (2) made of a steel frame with a filling of waterproof plywood. The plywood edges are protected additionally with an impregnant and plastic sealing compound where it is mostly exposed to dampness.

The rear part of the box contains a gate (4) used to lead animals in and to close the box. Tension springs (5) are used to facilitate the opening and closing of the tailgate. The tailgate is interlocked with a lock (6). The locking lever is protected against accidental opening with a cotter pin (7).

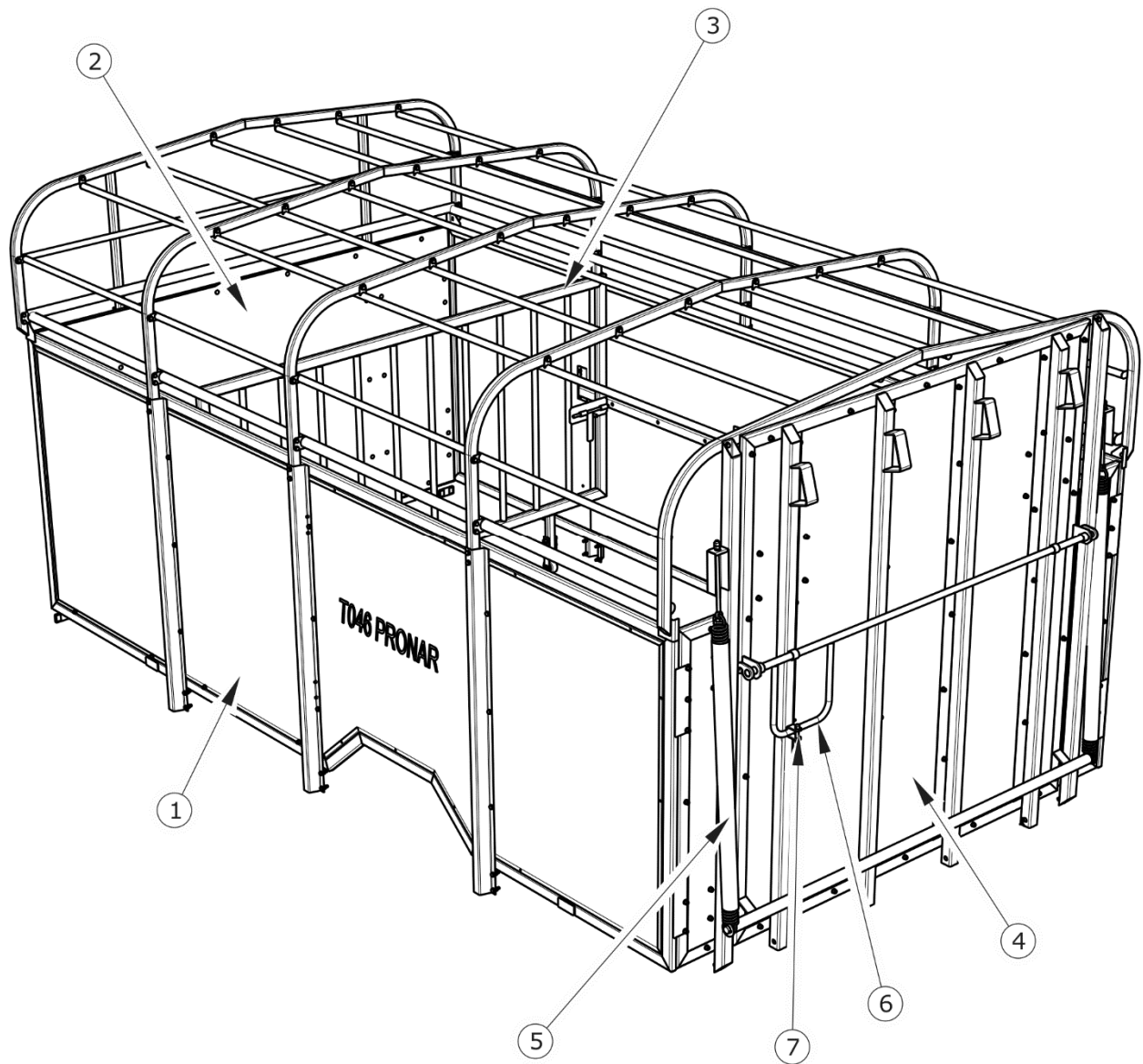

FIGURE 3.2 Load box

(1) side wall, (2) front wall, (3) partition, (4) tailgate, (5) tension spring, (6) tailgate lock, (7) securing cotter pin

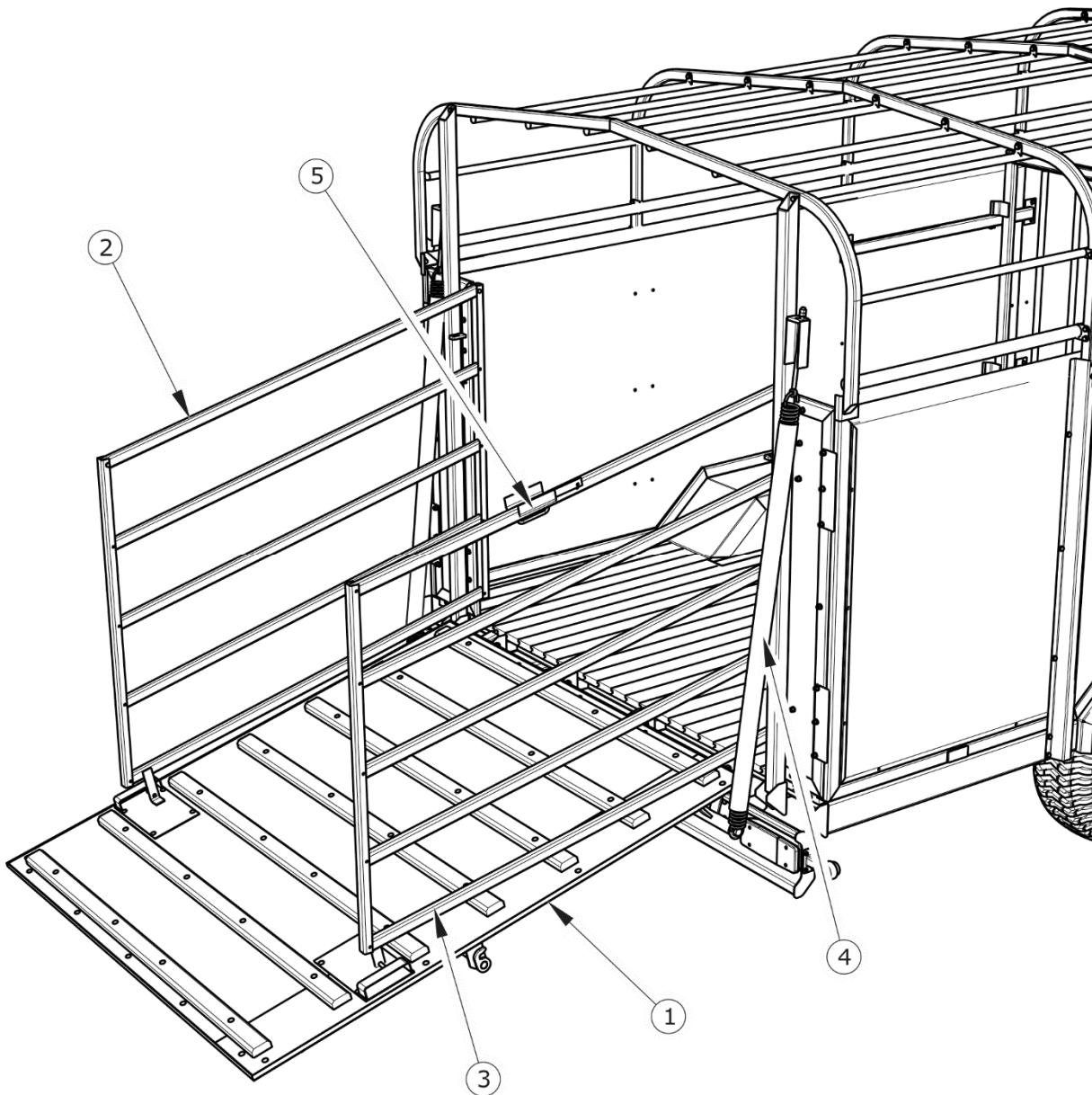

FIGURE 3.3 Tailgate and doors

(1) tailgate, (2) left door, (3) right door, (4) tension spring, (5) door lock

There are two doors – left (2) and right (3) – behind the tailgate – figure (3.3). During transport, the doors are secured with a lock (5). While loading or unloading animals, after the tailgate is lowered, the doors are opened outwards to form a passage enclosed on the right and left sides.

Inside the box there is a partition (1) – figure (3.4), to separate the load space for the duration of the animal transport. The partition is attached by means of hinges fixed to a rack (5) and locked with an interlock (3) in a profile (4).

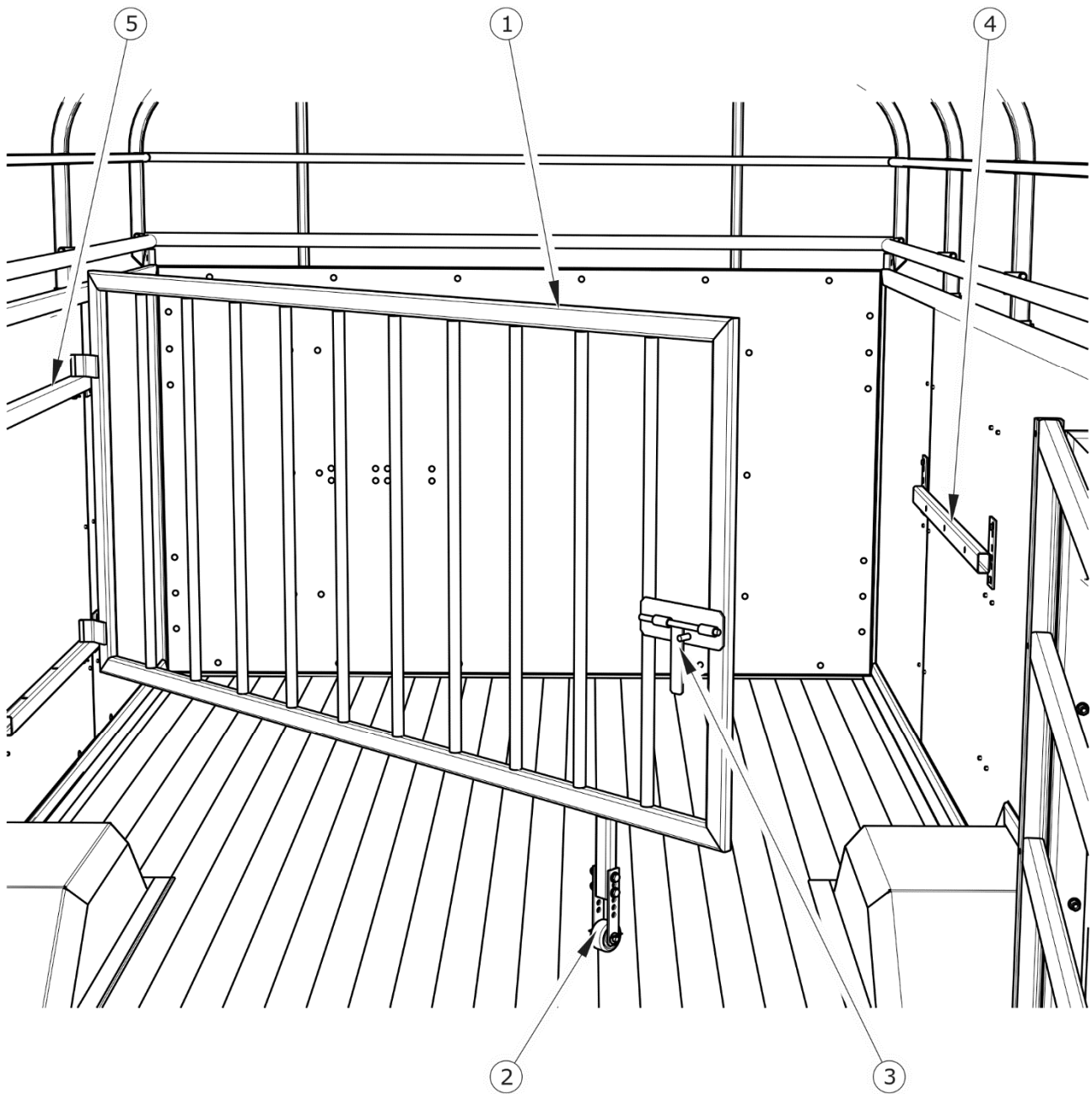

FIGURE 3.4 Internal partition

(1) partition, (2) partition wheel, (3) bolt, (4) interlock profile, (5) partition rack

3.2.3 FRAME WITH TARPAULIN COVER

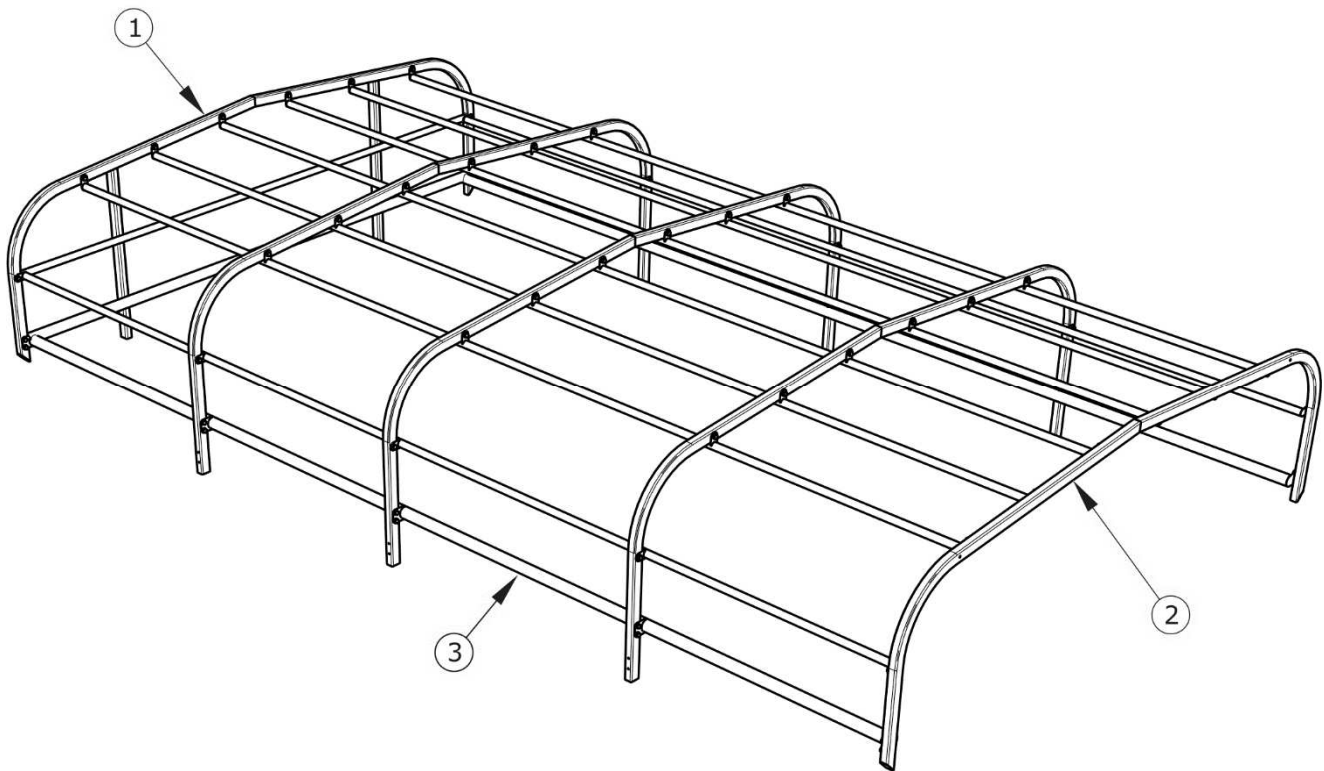

FIGURE 3.5 Frame

(1) front bow, (2) rear bow, (3) frame crosspiece

The frame is a steel structure made of bent steel profiles (frame bows) and tubes forming frame crosspieces (3). The entire structure is fixed to the walls of the load box by means of bolted joints. The lower crosspiece (3) of the frame is used to tether animals for transport.

3.2.4 ELECTRICAL SYSTEM

The electrical system of the trailer is adapted for the direct current supply of 12 V. The trailer is connected to the tractor by a connection cable, part of the standard machine equipment.

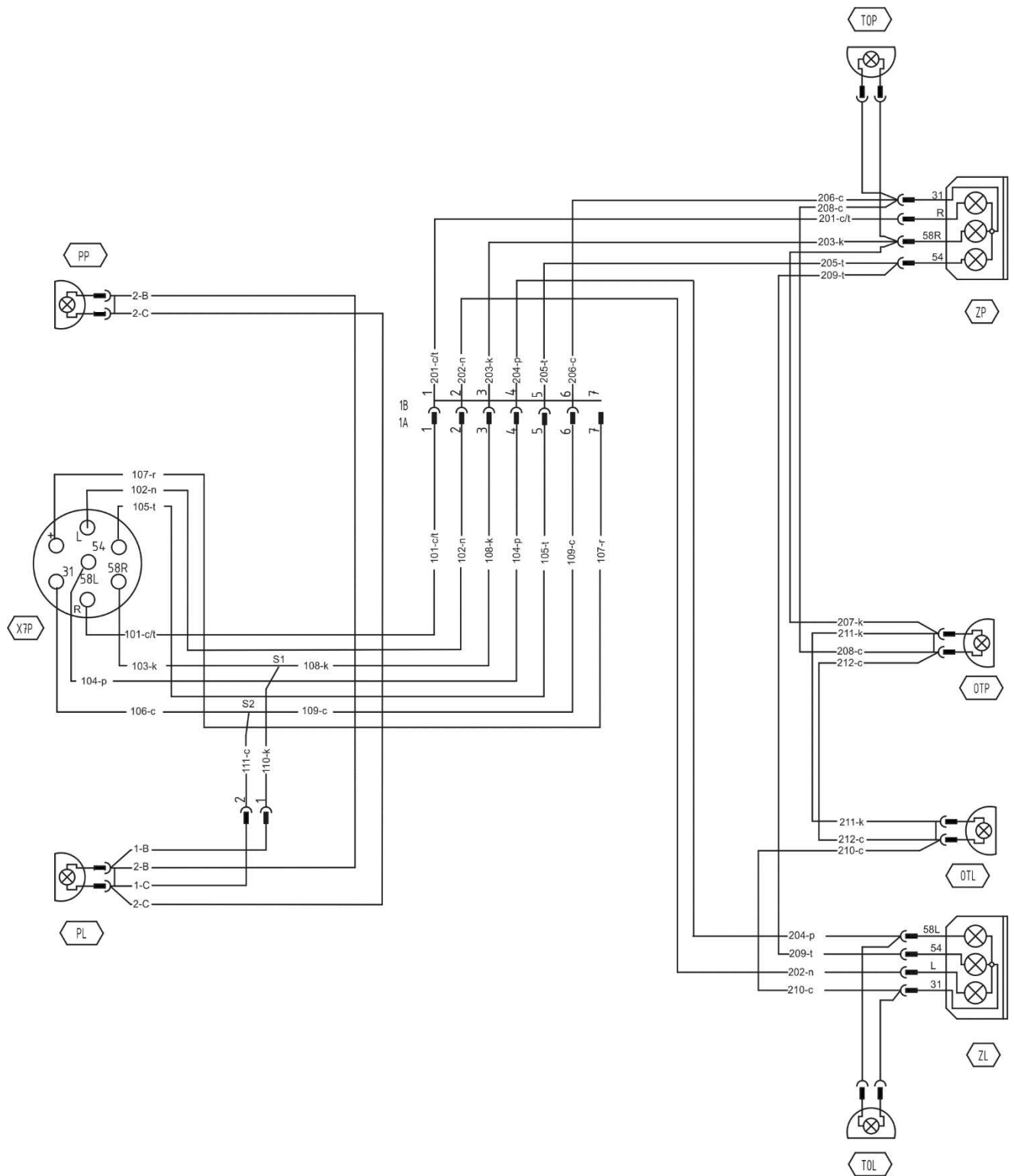

FIGURE 3.6 Electrical system concept diagram

Designations used in the figure are described in tables (3.2), (3.3) and (3.4)

TABLE 3.2 Lead colour marking

MARKING	LINE COLOUR
B	White
C	Black
K	Red
N	Blue
P	Orange
T	green
C/T	Black and green

TABLE 3.3 List of electrical component markings

SYMBOL	NAME OF COMPONENT
ZP	Rear right lamp assembly
ZL	Rear left lamp assembly
X7P	Front seven pin socket
TOP	Right rear clearance lamp
TOL	Left rear clearance lamp
OTP	Right license plate light
OTL	Left license plate light
PP	Front right parking light
PL	Front left parking light

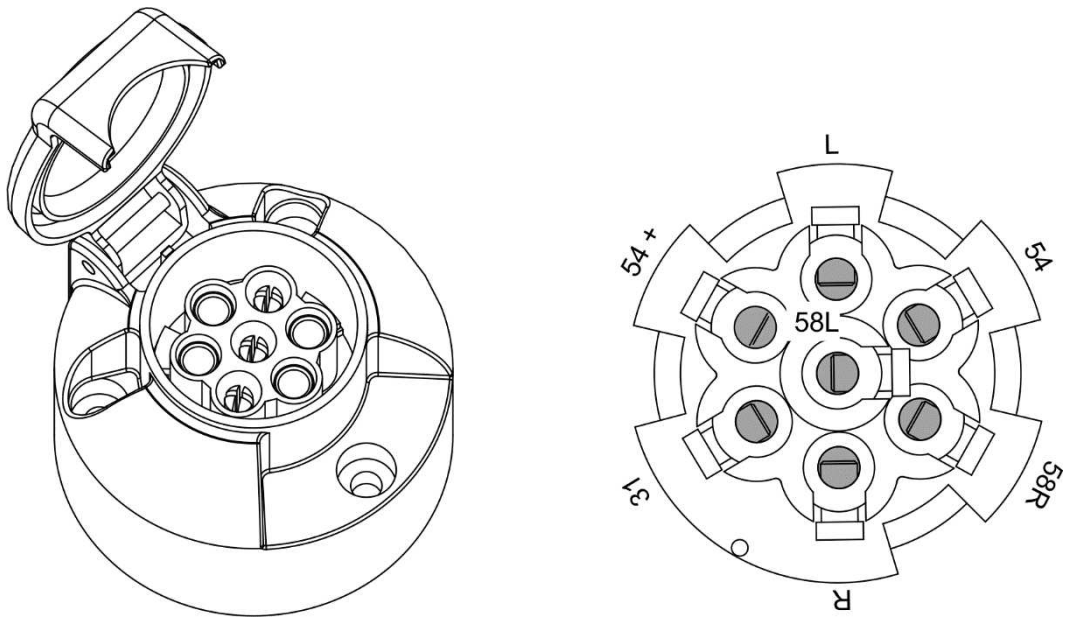

FIGURE 3.7 Connection socket X7P

TABLE 3.4 Socket connection markings

MARKING	FUNCTION
31	Weight
+	Power supply +12V
L	Left indicator
54	STOP light
58L	Front left parking light
58R	Front right parking light
R	Right indicator

3.2.5 MAIN BRAKE

The trailer is equipped with one of four types of main brake:

- double conduit pneumatic brake system with a three position regulator, figure (3.8) - optional equipment,
- single conduit pneumatic system with a three position regulator, figure (3.9) - standard equipment,

- hydraulic braking system – figure (3.10) - optional equipment,
- overrun brake, figure (3.12) – optional equipment.

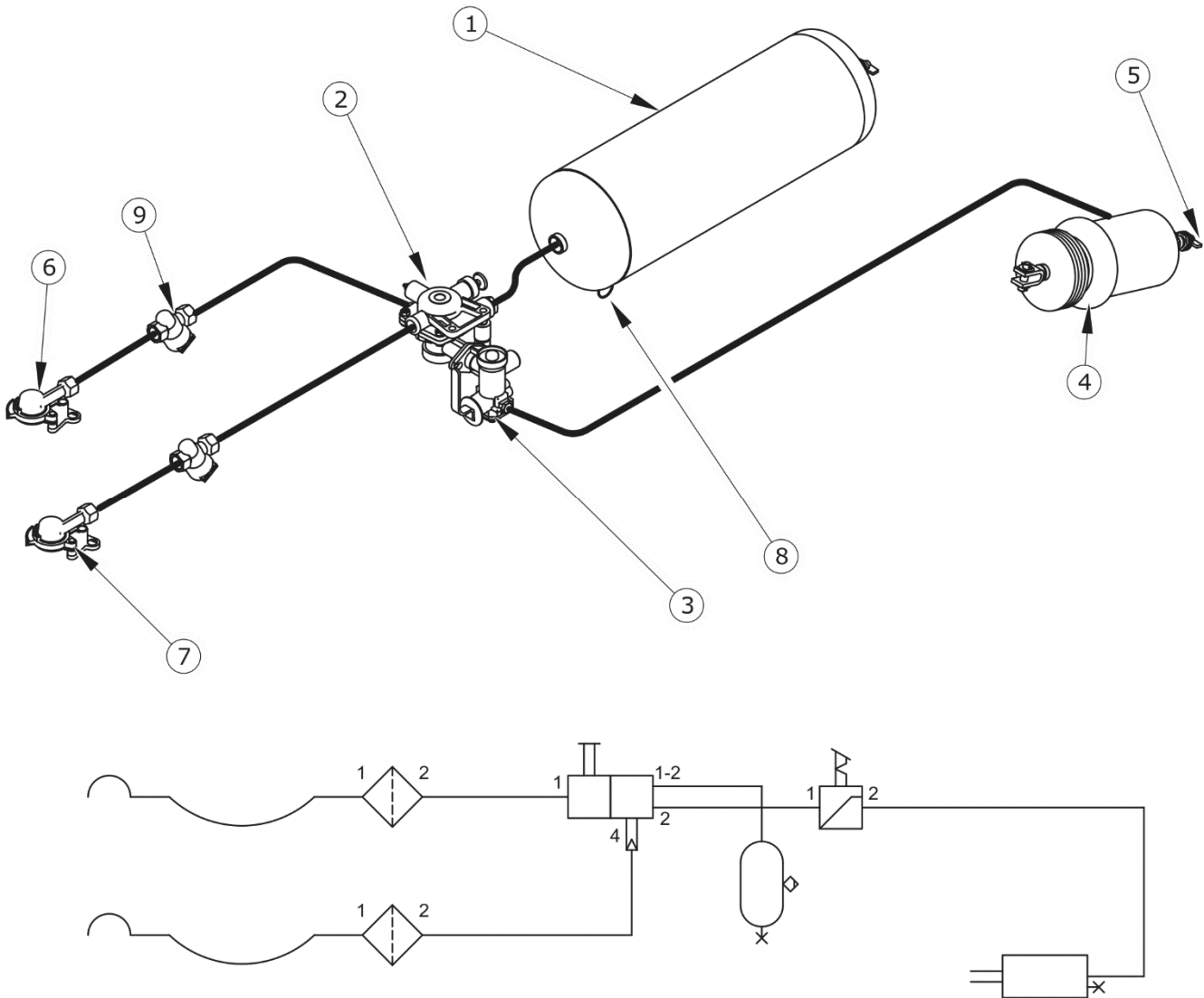

FIGURE 3.8 Design and diagram of the double conduit pneumatic system.

(1) air tank, (2) control valve, (3) braking force regulator, (4) pneumatic cylinder, (5) pneumatic cylinder control connector, (6) line connector (yellow), (7) line connector (red), (8) drain valve, (9) air filter

The main brake (pneumatic or hydraulic brake) is activated from the tractor driver's cab by depressing the brake pedal. The function of the control valve (2) - figure (3.8) and (3.9) is to activate the trailer's brakes simultaneously with the tractor's brakes. Furthermore, in case of

an inadvertent disconnection of the line between the trailer and the tractor, the control valve will automatically activate trailer's brakes.

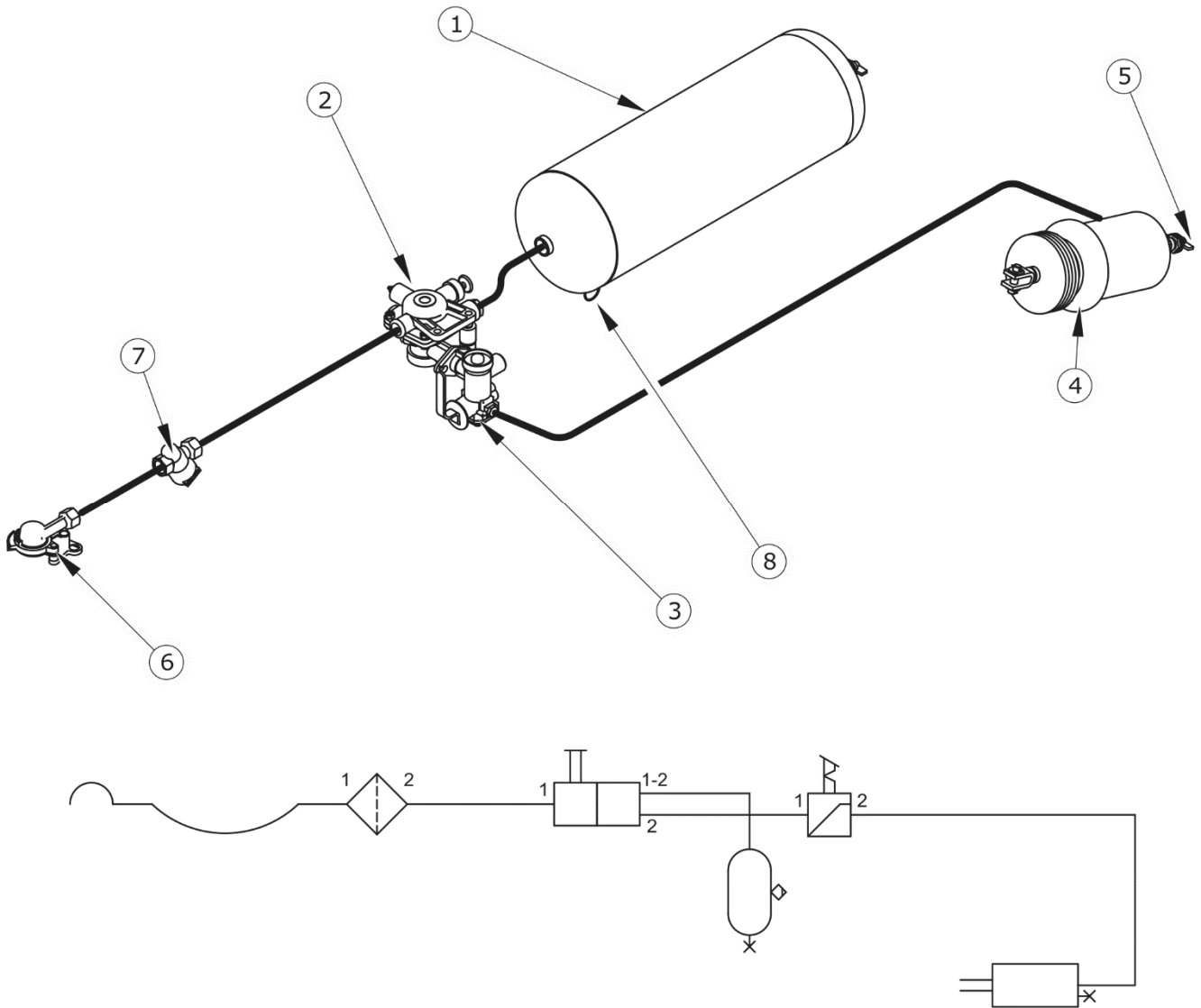

FIGURE 3.9 Design and diagram of the single conduit pneumatic system

(1) air tank, (2) control valve, (3) braking force regulator, (4) pneumatic cylinder, (5) pneumatic cylinder control valve, (6) line connector, (7) air filter, (8) drain valve

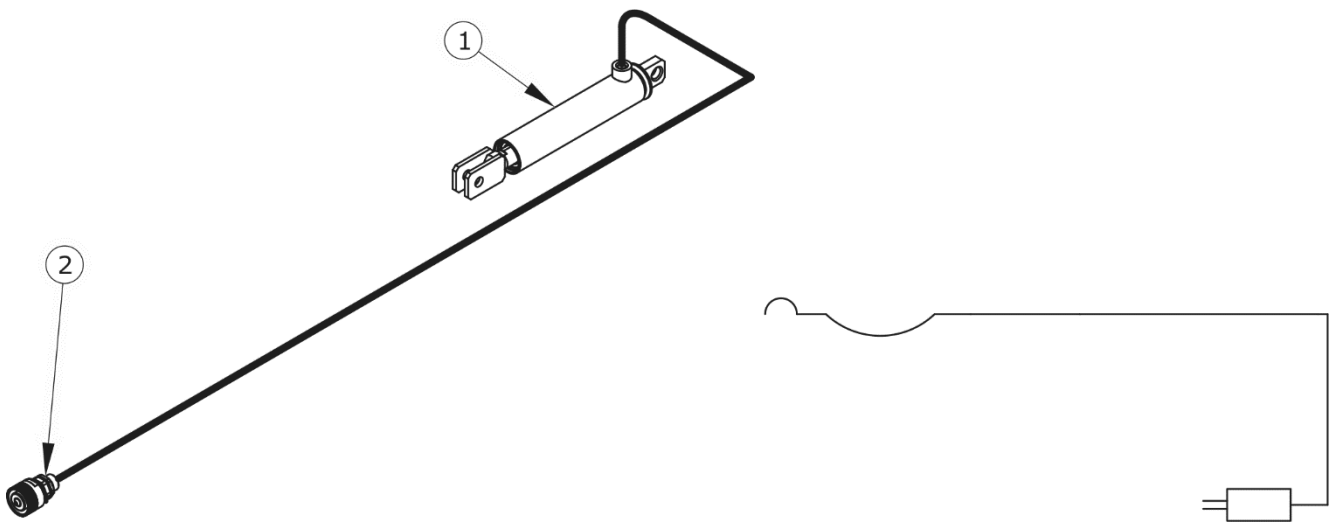

FIGURE 3.10 Hydraulic brake system construction and diagram

(1) hydraulic cylinder, (2) hydraulic quick coupler

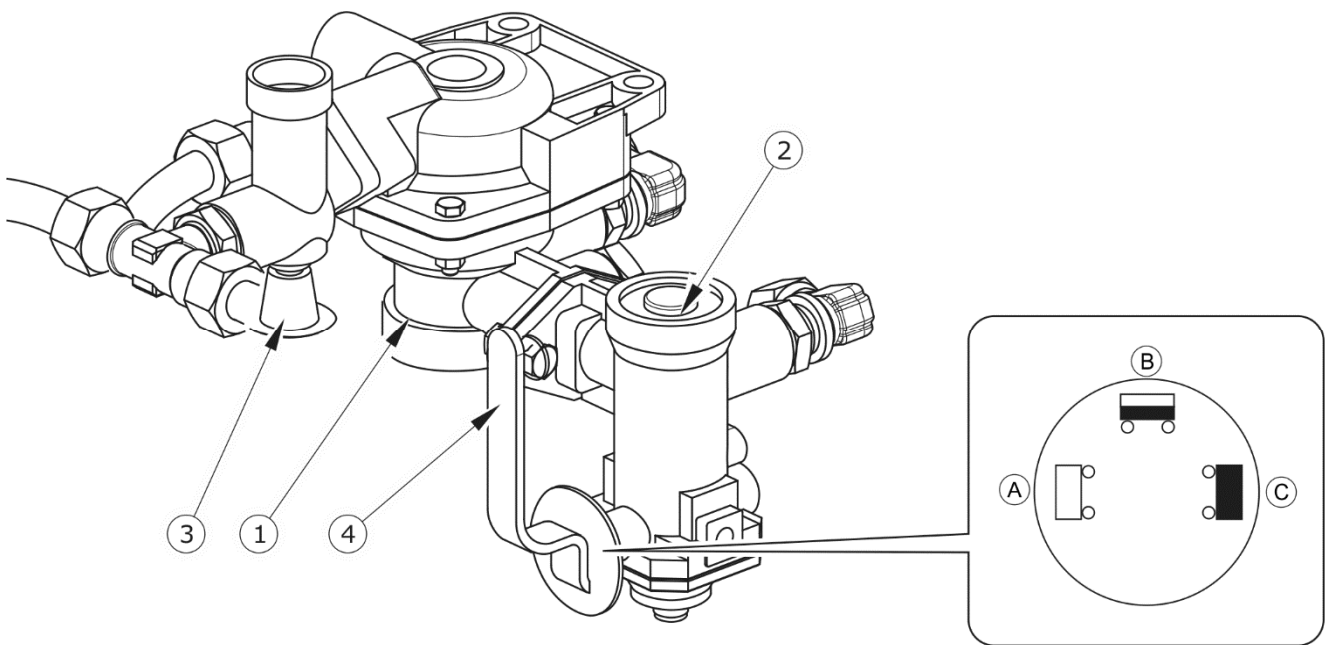

FIGURE 3.11 Control valve and brake force regulator

(1) control valve, (2) brake force regulator, (3) trailer parking brake release button, (4) work selection regulator lever, (A) position "NO LOAD", (B) position "HALF LOAD", (C) position "FULL LOAD"

Valve used in the system is equipped with a circuit causing the brakes to be applied when trailer is disconnected from the tractor, compare with figure (3.11). When compressed air line is connected to the tractor, the device automatically applying the brakes now changes its position to allow normal brake operation.

Three-step brake force regulator (2)- figure (3.11), adjusts braking force depending on setting. Switching to a suitable working mode is done manually by machine operator using the lever (4) prior to moving off. Three working positions are available: A - "no load", B - "half load" and C - "full load".

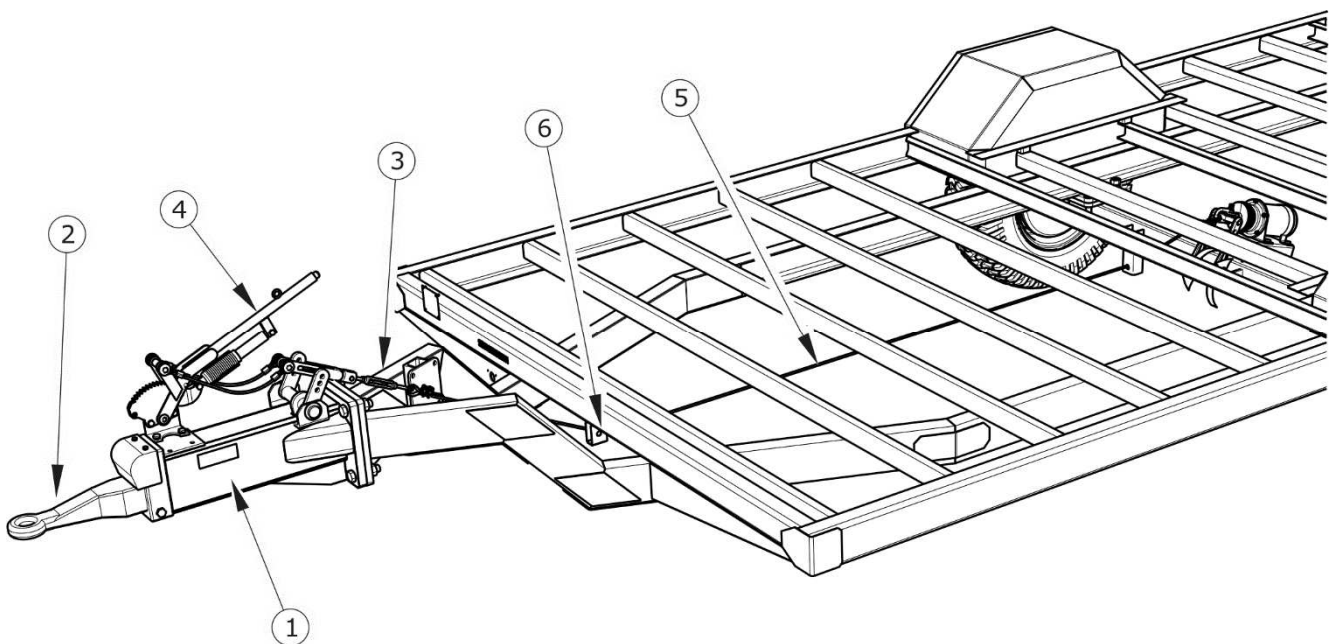

FIGURE 3.12 **Overrun brake**

(1) overrun drawbar, (2) overrun drawbar eye, (3) brake cable tightener, (4) parking brake lever, (5) brake cable, (6) cable roller

Overrun brake system design is shown in figure (3.12). The overrun drawbar (1) with a moving eye (2) is fixed, as standard, to the lower frame of the trailer. The eye is connected by means of the brake cable (5) to the axle – overrun version. When the brake in the tractor is activated, the speeding trailer applies pressure to the tractor's hitch and in consequence the drawbar eye slides into the body and tightens the cable (5). The steel cable is connected to the expanding levers of the wheel axle which activate the trailer brakes.

The overrun axles have a mechanism preventing the locking while the trailer is reversing.

The trailer with an overrun brake does not have a separate parking brake.

3.2.6 PARKING BRAKE

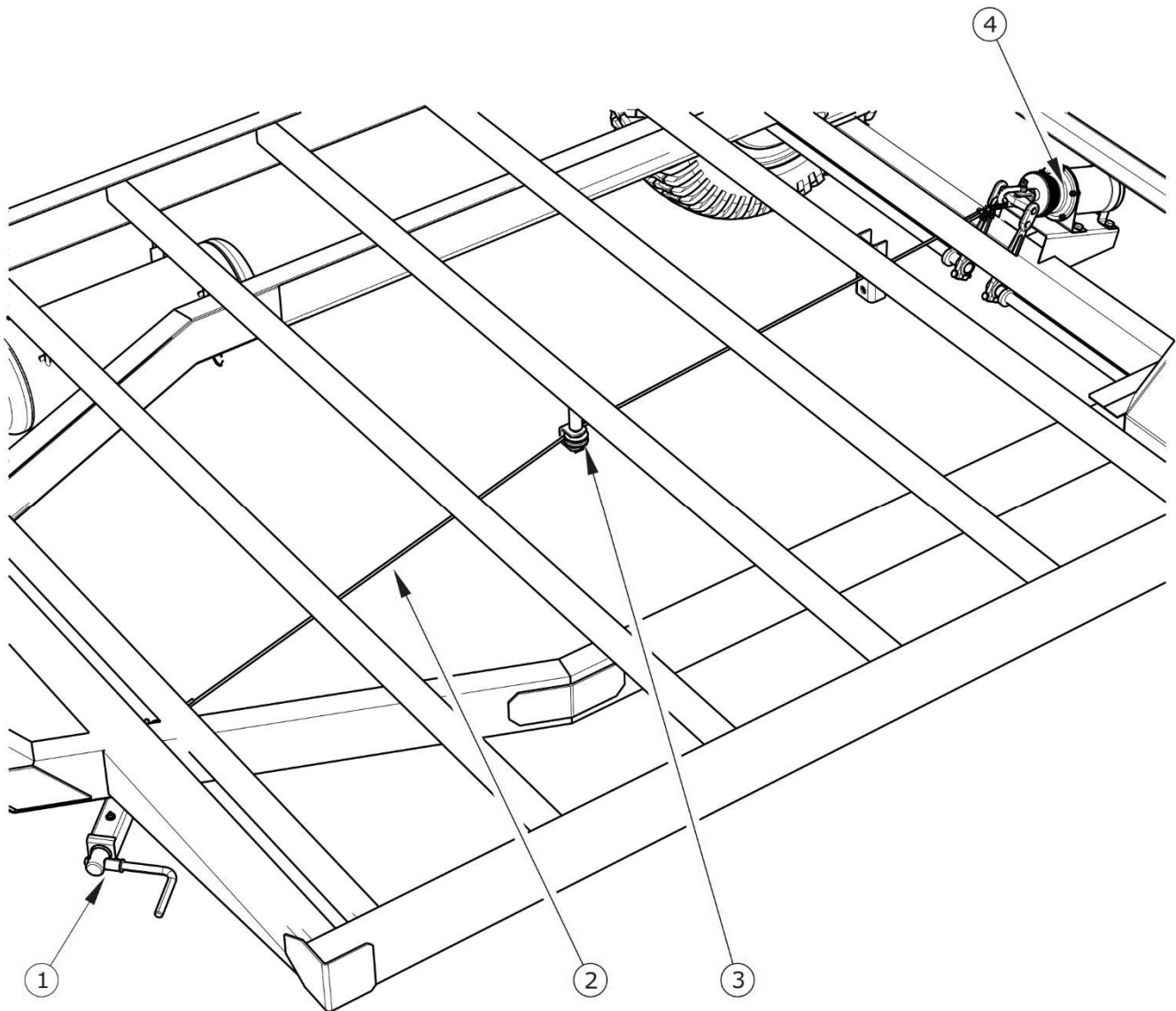

FIGURE 3.13 Parking brake

(1) brake crank mechanism, (2) steel cable, (3) roller, (4) brake cylinder

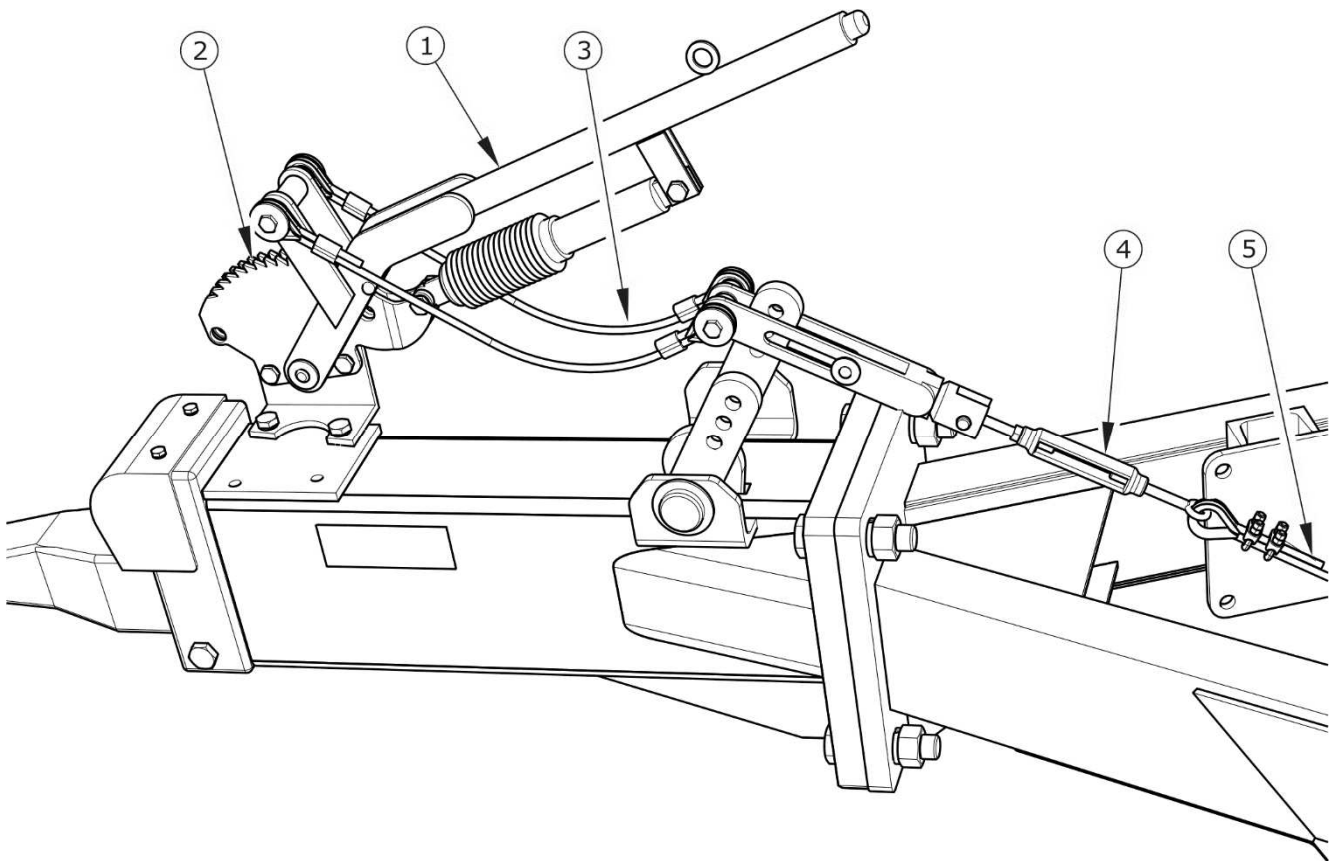

FIGURE 3.14 Overrun brake drawbar

(1) lever, (2) ratchet gear, (3) cable, (4) tightener, (5) overrun brake cable

The parking brake is for immobilising trailer while standing motionless. The trailer may be equipped with one of two types of the parking brake:

- parking brake operated by crank mechanism (1) – standard equipment - figure (3.13),
- parking brake operated by a lever mechanism, integrated with the overrun brake – optional equipment – figure (3.14).

The standard construction of the system is show in figure (3.13). The brake crank mechanism (1) is welded to the front beam of the lower frame. The steel cable (2) is connected to the wheel axle's expander levers by means of a screw shackle, roller (3) to the crank mechanism (1). Tightening the cable causes tilting of the expander lever, which parts the jaws of the brake shoes immobilising the trailer.

If the trailer has the overrun brake, the parking brake is integrated with the overrun brake. The parking brake is operated by a lever (1) – figure (3.14). Once set to the braking position,

the ratchet prevents the lever from returning automatically to the initial position. To release the brake, press the push button in the lever handle.

SECTION

4

**CORRECT
USE**

4.1 PREPARING THE TRAILER FOR WORK

4.1.1 PRELIMINARY INFORMATION

The trailer is supplied to the user completely assembled and does not require additional mounting operations of machine sub-assemblies. The manufacturer guarantees that the machine is fully operational and has been checked according to quality control procedures and is ready for use. This does not release the user from an obligation to check the machine's condition prior to purchasing and before first use.

4.1.2 HAND-OVER AND INSPECTION OF THE MACHINE AFTER DELIVERY

After delivery of the machine to the buyer, the user is obliged to check technical condition of the trailer (one-time inspection). While buying the machine, the user must be informed by the seller about the method of use of the trailer, risks resulting from the use for purposes other than intended, the method of the machine hitching and the principles of the machine construction and design. Detailed information concerning the machine hand-over are included in the *WARRANTY BOOK*.

Checking the trailer after delivery

- ➔ Check completeness of the trailer according to order.
- ➔ Check technical condition of safety guards.
- ➔ Check condition of paint coating; check the machine for traces of corrosion.
- ➔ Check the technical condition of the floor and walls.
- ➔ Check the machine for damage resulting from wrong transport of the machine to its destination (crushing, piercing, bending or breaking of minor elements etc.).
- ➔ Check air pressure in tyres and check correct tightening of wheel nuts.
- ➔ Check technical condition of drawbar eye and if correctly installed.

If non-conformities are found, do not hitch and start using the trailer. Discovered defects should be notified directly to the seller in order to remove them.

**NOTE**

The seller is obliged to conduct the first start up of the trailer in the presence of the user.
The user trained by the seller is not released from the obligation to read this operator's manual carefully.

4.1.3 PREPARING THE TRAILER FOR THE FIRST USE, TEST RUN OF THE TRAILER

**TIP**

All maintenance activities concerning the trailer are described in detail in further sections of the Operator's Manual.

Preparing for the test run

- ➔ The user must carefully read this *OPERATOR'S MANUAL* and observe all its recommendations.
- ➔ Visually inspect the trailer according to guidelines presented in section *PREPARING THE TRAILER FOR NORMAL USE*.
- ➔ Hitch machine to tractor. Immobilise tractor with parking brake.

Test start

- ➔ Check all the trailer's lubrication points, lubricate the machine as needed according to recommendations provided in section 5,
- ➔ Check the correct opening of the tailgate, locking of locks, completeness of securing cotter pins,
- ➔ Drain air tank of the brake system.
- ➔ Ensure that pneumatic, hydraulic and electric connections in agricultural tractor are according to the requirements, if not the trailer should not be hitched to the tractor.
- ➔ Switch on individual lights, check correct operation of electrical system.

- ➔ Release tractor's parking brake. Perform test drive. Check the trailer's braking efficiency during driving.

If during test run worrying symptoms occur such as:

- excessive noise and abnormal sounds originating from the rubbing of moving elements,
- leaky brake system, hydraulic oil leaks,
- incorrect operation of brake cylinders,
- other suspected faults,

stop operating the trailer and do not operate it until the malfunction is corrected. If a fault cannot be rectified or the repair could void the warranty, please contact retailer for additional clarifications or to perform the repair.

4.1.4 PREPARING THE TRAILER FOR NORMAL USE

DANGER



Careless and improper use and operation of the trailer, and non-compliance with the recommendations given in this operator's manual is dangerous to your health.

The trailer must never be used by persons, who are not authorised to drive agricultural tractors, including children and people under the influence of alcohol or other drugs.

Non-compliance with the safety rules of this Operator's Manual can be dangerous to the health and life of the operator and others.

Scope of inspection activities

- ➔ Visually inspect if the tyres are properly inflated. In case of doubt, carefully check tyre pressure.
- ➔ Check technical condition of drawbar eye.
- ➔ Check correctness of electrical system operation.
- ➔ Check technical condition and completeness of safety guards.
- ➔ Install the triangular slow-moving vehicle warning sign - if the trailer is used - on public roads.

4.2 HITCHING AND UNHITCHING THE TRAILER

Ensure that hydraulic, pneumatic and electric connections and the hitch of agricultural tractor are according to the Manufacturer's requirements, if not the trailer should not be hitched to the tractor. In order to hitch the trailer to the tractor perform the actions below in the sequence presented.

Hitching to tractor

- ➔ Position agricultural tractor directly in front of the trailer's drawbar eye.
- ➔ Position drawbar eye at the correct height.
 - ⇒ Turn the crank towards direction (A) to raise the drawbar eye.
 - ⇒ Turn the crank towards direction (B) to lower the drawbar eye.
- ➔ Reverse tractor, hitch trailer to appropriate hitch on tractor, check hitch lock protecting machine against accidental unhitching.
 - ⇒ If the agricultural tractor is equipped with an automatic coupler, ensure that the hitching operation is completed and that drawbar eye is secured.
 - ⇒ The tractor hitch is selected depending on the trailer's drawbar eye.
- ➔ Turn off tractor engine. Ensure that unauthorised persons do not have access to the tractor cab.
- ➔ Connect pneumatic system lines (applies to single or double line systems):
 - ⇒ Connect pneumatic line marked yellow with yellow socket in tractor (double line system).
 - ⇒ Connect pneumatic line marked red with red socket in tractor (double line system).
 - ⇒ Connect pneumatic line marked black with black socket in tractor (single line system).
 - ⇒ Connect hydraulic brake system (applies to trailer version with hydraulic brake).
- ➔ Connect connection lead for the electrical system

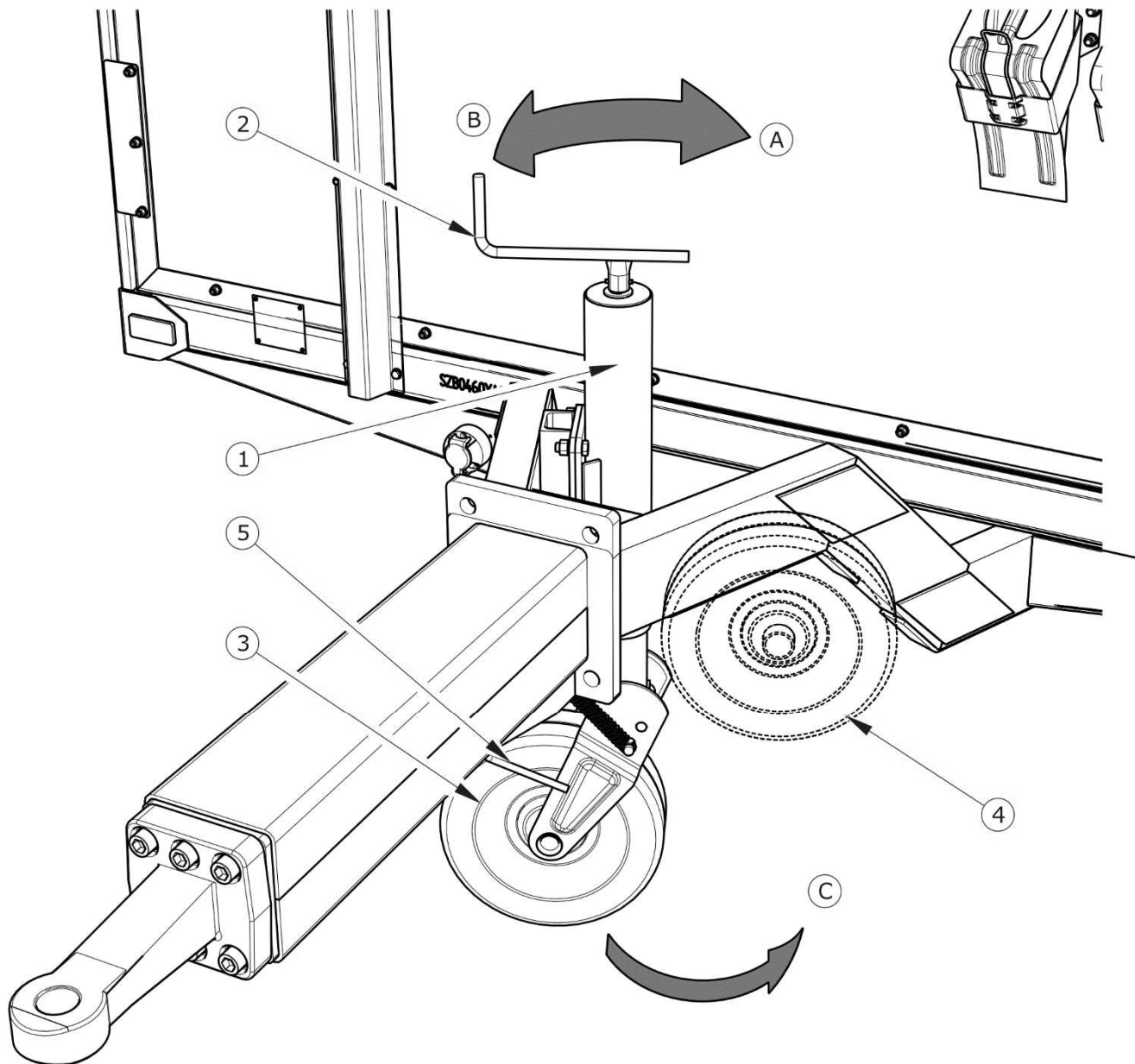

FIGURE 4.1 Support operation

(1) support, (2) crank, (3) support wheel (parked), (4) support wheel (during transport), (5) pedal, (A) raising the wheel / lowering the drawbar eye, (B) lowering the wheel / raising the drawbar eye, (C) wheel turn direction

- Raise the support wheel to the extreme top position.
- Press the pedal (5) and hold the support wheel to turn it to the transport position.
- Check and, if necessary, protect conduits against rubbing or other mechanical damage.

- ➔ Immediately before moving, remove the chocks from under the trailer wheels and place them in the appropriate holders on the rear wall of the tank.

IMPORTANT!



The trailer must not be used when not in working order.

When turning, line connection tubes must hang loosely and not become tangled with moving elements of trailer and tractor.

When the trailer is travelling, the support wheel shall be raised and turned to the transport position.

If the agricultural tractor is equipped with an automatic coupler, ensure that the hitching operation is completed and that drawbar eye is secured.

DANGER



When hitching, there must be nobody between the trailer and the tractor. When hitching the machine, tractor driver must exercise caution and make sure that nobody is present in the hazard zone.

When connecting the hydraulic or pneumatic conduits to the tractor, make sure that the hydraulic and pneumatic systems of the tractor and the trailer are not under pressure.

Ensure sufficient visibility during hitching.

Exercise particular caution during support operation - danger of severing limbs.

After completion of hitching check the security of the hitching pin.

Unhitching

In order to disconnect the trailer from the tractor follow these steps.

- ➔ Immobilise tractor with parking brake, turn off tractor engine
- ➔ Ensure that unauthorised persons do not have access to the tractor cab.
- ➔ Place chocks under the trailer's wheels in order to prevent the machine from rolling.
- ➔ Turn the crank to lower the support wheel.
 - ⇒ Set the drawbar eye at such a height that one may safely unlock and unhitch the trailer's drawbar eye.
- ➔ Disconnect electric lead.

- ➔ Disconnect pneumatic system conduits (applies to double conduit systems):
 - ⇒ Disconnect pneumatic conduit marked red.
 - ⇒ Disconnect pneumatic conduit marked yellow.
- ➔ Disconnect pneumatic system lines (applies to single line systems):
 - ⇒ Disconnect pneumatic conduit marked black.
- ➔ Disconnect hydraulic braking system conduits (applies to trailer version with hydraulic braking system).
- ➔ Protect conduit ends with covers.
- ➔ Disengage transport hitch and disconnect trailer drawbar from tractor hitch and drive tractor away.

DANGER



Exercise caution when disconnecting trailer from the tractor. Ensure good visibility. Unless it is necessary, do not go between tractor and machine.

Before disconnecting conduits and drawbar eye, close tractor cab and secure it against access by unauthorised persons. Turn off tractor engine.

DO NOT unhitch the trailer if there are animals in the load box.

4.3 LOADING AND UNLOADING ANIMALS

4.3.1 PREPARING THE TRAILER FOR WORK

Description of activities

- ➔ Hitch trailer to tractor. Immobilise tractor and trailer with parking brake.
- ➔ Park the trailer on flat ground.
- ➔ Remove the triangular slow-moving vehicle sign (5) – figure (4.2).
- ➔ Take out the cotter pin (3) securing the locked tailgate, open and lower the tailgate.
 - ⇒ Tension springs make it so easy to lower or raise the tailgate that a single person may do this operation.

- ➔ Raise the door lock (3) – figure (4.3).
- ➔ Open the left door and then the right door.
- ➔ Position the doors placing the door leg with the pin under lock plate U-section (4).
- ➔ Open the internal partition (additional equipment).



FIGURE 4.2 Tailgate

(1) tailgate, (2) tension springs, (3) securing cotter pin, (4) tailgate locking lever, (5) triangular sign

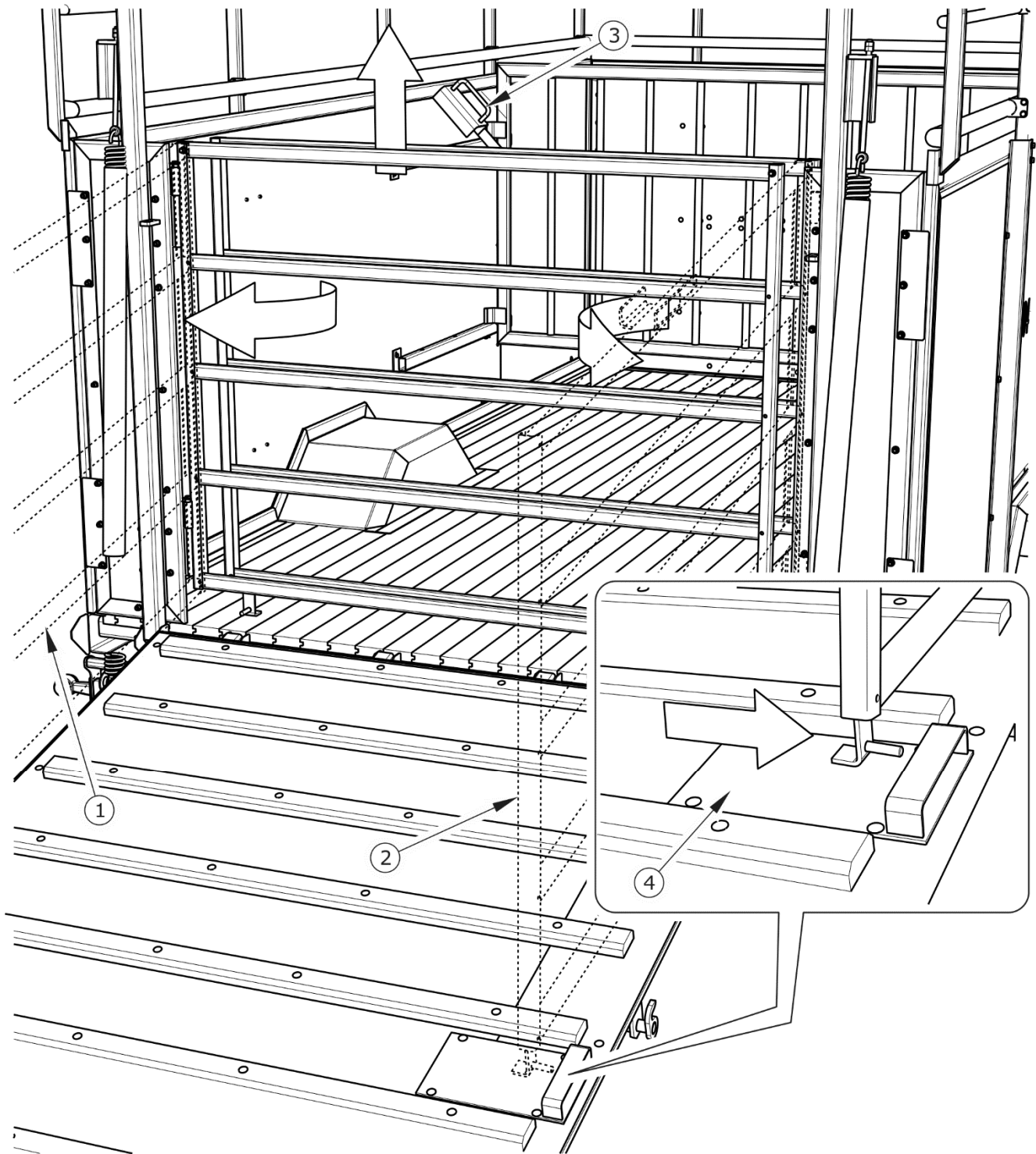

FIGURE 4.3 Opening doors

(1) left door open, (2) right door open, (3) door lock, (4) door lock plate

**DANGER**

When lowering the tailgate, be particularly careful as your whole body may be crushed.

4.3.2 LOADING AND UNLOADING

FIGURE 4.4 Opening doors

(1) *frame crosspiece*

Recommendations

Due to difficulties related to the unpredictable behaviour of animals and their different sizes as well as other factors, it is impossible to compile detailed guidelines concerning the loading and placement of cattle inside the trailer. Nevertheless, the Manufacturer's general recommendations for the above-mentioned operations shall be followed.

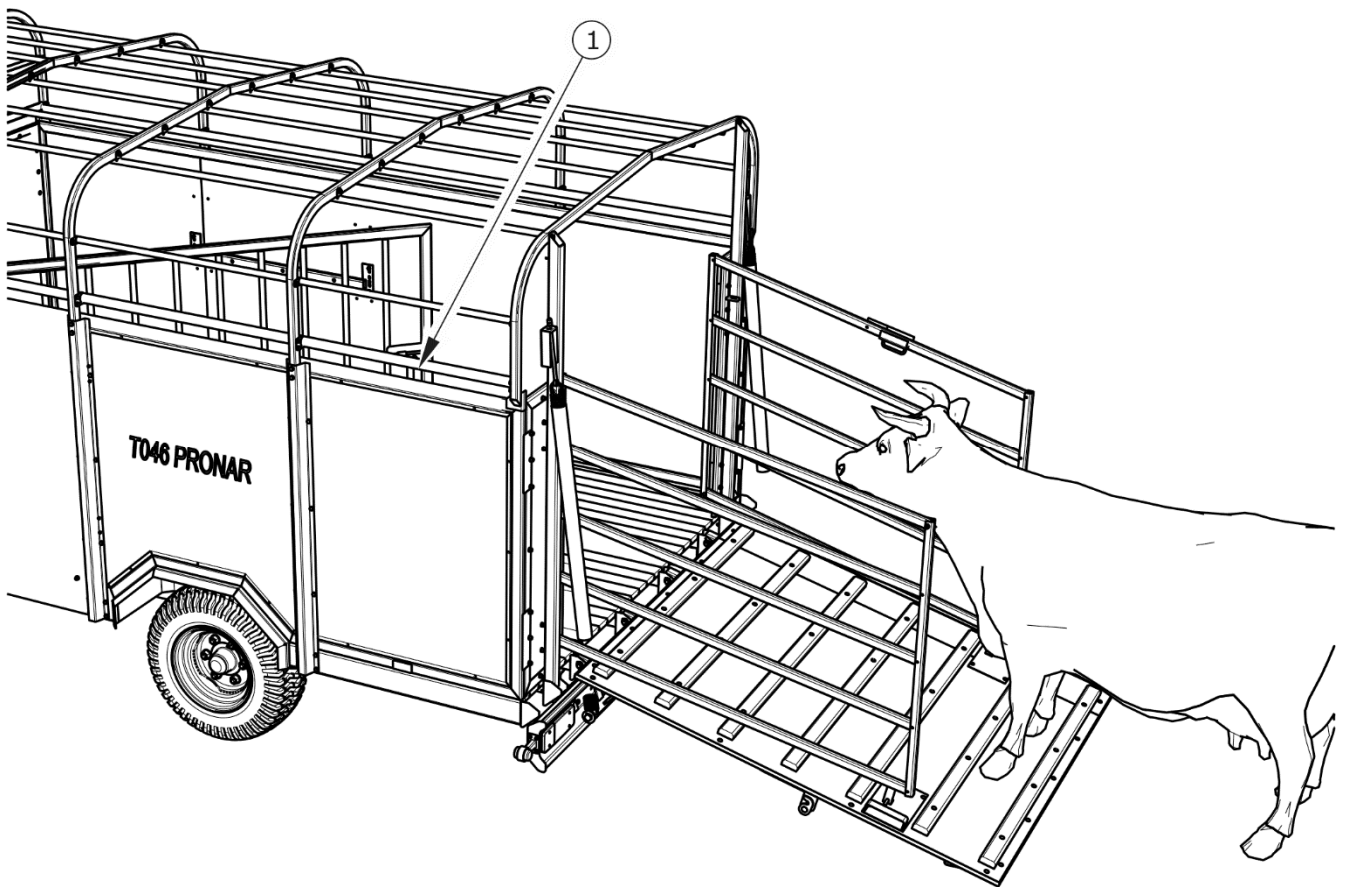
- Place the internal partition as required.

- Bring animals to the trailer one by one.
- Once a single animal is brought inside, tether it to the frame crosspiece (1) – figure (4.4), the one nearest the top edge of the load box walls.
- DO NOT injure animals.
- Animals to be transported should be arranged uniformly over the entire surface of the trailer.
- Do NOT exceed permissible load weight of trailer because this may cause danger to road traffic and cause damage to the trailer.
- Before starting to lead animals out of the trailer, make sure they do not press against the tailgate or side barriers.
- Be careful during the loading and unloading.

4.4 TRANSPORT OF ANIMALS

When towing the trailer on public or private roads, respect the road traffic regulations, exercise caution and prudence. Listed below are the key guidelines for driving the tractor and the trailer for transporting animals.

- DO NOT transport animals which are not fit for transport.
- Before moving off make sure that there are no bystanders, especially children, near the trailer or the tractor. Take care that the driver has sufficient visibility.
- Make sure that the trailer is correctly attached to the tractor and tractor's hitch is properly secured. All the components of the trailer shall be locked properly (tailgate, internal partition, rear doors) and animals shall be tethered to a frame pipe.
- Avoid sudden acceleration, turning and braking.
- Transported animals should be provided with comfort and safety.
- The trailer must not be overloaded, the animals should be uniformly distributed. The trailer's maximum carrying capacity must not be exceeded as this can damage the trailer and pose a risk to the operator or other road users.

- Permissible design speed and maximum speed allowed by road traffic law must not be exceeded. Speed of travel should be adjusted to prevailing road conditions, load carried and other conditions.
- When not connected to the tractor, the trailer must be immobilised using parking brake and with chocks placed under the wheels. Do NOT leave unsecured trailer.
- In the event of trailer malfunction, pull over on the hard shoulder avoiding any risk to other road users and position reflective warning triangle according to traffic regulations.
- When driving on public roads trailer must be marked with a slow-moving vehicle warning sign attached to the gate of the rear load box. While driving on public roads the trailer must be fitted with a certified or authorised reflective warning triangle. When driving, comply with all road traffic regulations, indicate an intention to turn using indicator lamps, keep all road lights and indicator lights clean at all times and ensure they are in good condition. Any damaged or lost lamps or indicator lights must be immediately repaired or replaced.
- Avoid ruts, depressions, ditches or driving on roadside slopes. Driving across such obstacles could cause the trailer or the tractor to suddenly tilt. This is of special importance because loaded trailer's centre of gravity is higher, which reduces safety. Driving near ditches or channels is dangerous as there is a risk of the wheels sliding down the slope or the slope collapsing.
- Speed must be sufficiently reduced before making a turn or driving on an uneven road or a slope.
- When driving, avoid sharp turns especially on slopes.
- Please note that the braking distance of the tractor and trailer combination is substantially increased at higher speeds and loads.
- Monitor trailer's behaviour when travelling on an uneven terrain, and adjust driving speed to road conditions, slow down early enough when turning.

4.5 PROPER USE AND MAINTENANCE OF TYRES

- When performing maintenance and servicing of tyres, the trailer must be immobilized with parking brake and 2 chocks placed under the wheels.
- Repair work on the wheels or tyres should be carried out with use of appropriate tools by persons trained and entitled to do so.
- Inspect tightness of wheel nuts after the first use of the machine, after the first day of work under load, after travelling 1,000 km and then every 6 months of use or every 25,000 km. The inspection should be repeated individually if a wheel has been removed from the wheel axle.
- Regularly check and maintain correct pressure in tyres.
- Protect valves using suitable caps to avoid soiling.
- Do not exceed the maximum design speed of the trailer.
- When machine is operated all day, check temperature of tyres.
- Avoid potholes, sudden manoeuvres or high speeds when turning.

SECTION

5

MAINTENANCE

5.1 PRELIMINARY INFORMATION

When using the trailer, regular inspections of its technical condition and the performance of maintenance procedures are essential, which keep the machine in good technical condition. In connection with this the user of the trailer is obliged to perform all the maintenance and adjustment procedures defined by the Manufacturer.

Repairs during the warranty period may only be performed by authorised service points.

Detailed procedures and extent of activities which the user may perform by himself are described in this section. In the event of unauthorised repairs, changes to factory settings and other actions, which are not regarded as possible for the trailer operator to perform, the user shall invalidate the warranty.

5.2 SERVICING WHEEL AXLE

5.2.1 PRELIMINARY INFORMATION

Work connected with the repair, change or regeneration of axle components should be entrusted to specialist establishments, having the appropriate technology and qualifications for this type of work.

The responsibilities of the user are limited to:

- Inspection and adjustment of slackness of axle bearings,
- mounting and dismounting wheel, inspection of wheel tightening,
- checking air pressure, evaluating technical condition of wheels and tyres.
- mechanical brakes adjustment,
- change of parking brake cable and adjustment of cable tension.

Procedures connected with:

- changing grease in axle bearings,
- changing bearings, hub seals,
- repairing wheel axle,

may be performed by specialist workshops.

5.2.2 CHECK WHEEL AXLE BEARINGS FOR SLACKNESS

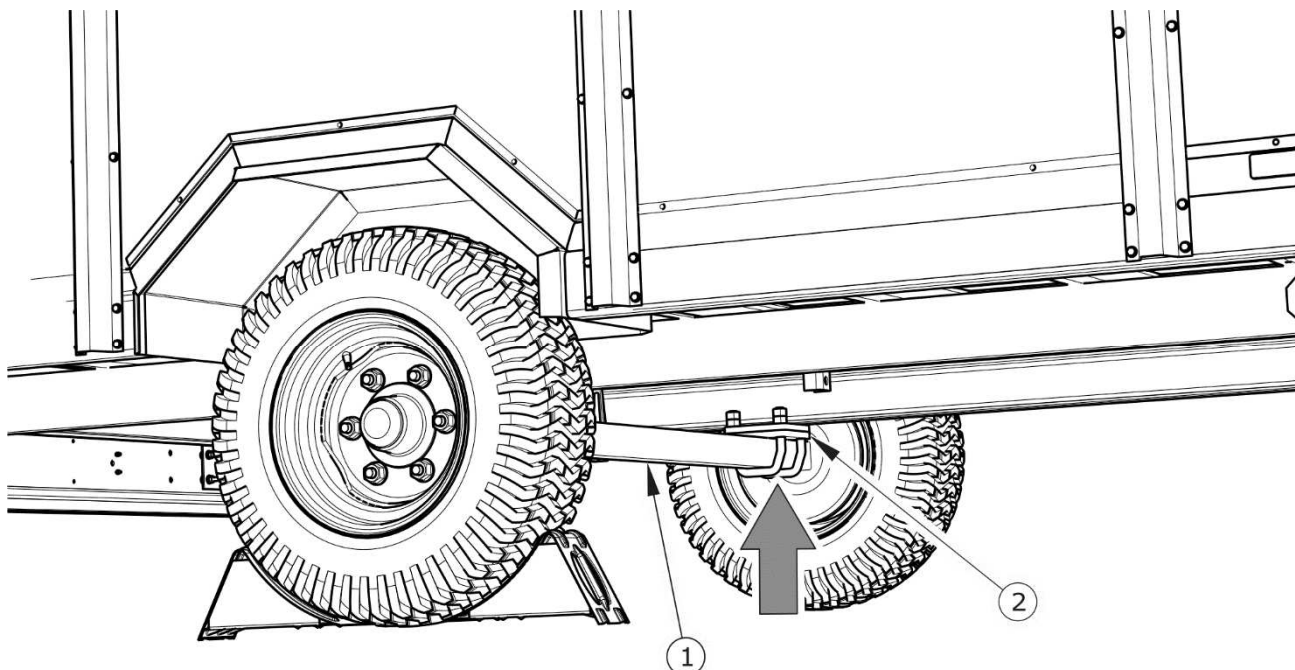

FIGURE 5.1 Lifting jack support point

(1) wheel axle, (2) axle fastening plate

Preparation procedures

- ➔ Hitch trailer to tractor, braking tractor with parking brake.
- ➔ Park tractor and trailer on hard level ground.
 - ⇒ Tractor must be placed to drive forward.
- ➔ Place chocks under the trailer's wheel that will not be raised. Ensure that machine will not move during inspection.
- ➔ Raise the wheel (opposite to the side where chocks are placed).
 - ⇒ Lifting jack should be positioned in the place indicated by the arrow in figure (5.1). Lifting jack must be suited to weight of trailer.

Checking slackness of wheel axle bearings

- ➔ Turning the wheel slowly in both directions check that movement is smooth and that the wheel rotates without excessive resistance.
- ➔ Turn the wheel so that it rotates very quickly, check that the bearing does not make any unusual sounds.
- ➔ Holding the wheel above and below, try to feel any slackness.
 - ⇒ You may use a lever placed under the wheel supporting the other end on the floor.
- ➔ Lower the lifting jack, relocate the chocks to the other wheel and repeat the inspection procedure for the other wheel.

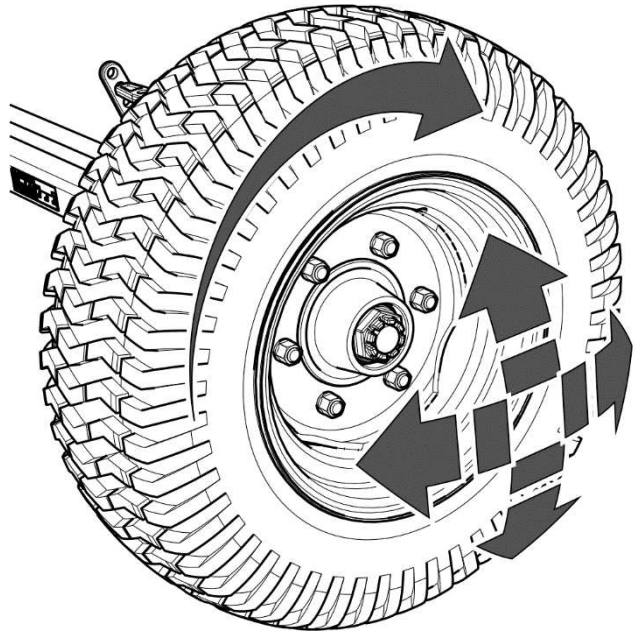

FIGURE 5.2 Checking wheel axle bearings for looseness

TIP



If hub cover is damaged or missing, contamination and dampness enter the hub, which causes significantly faster wear of bearing and hub seals.

Bearing life is dependent on working conditions of trailer, loading, speed of travel and lubrication conditions.

If slackness is felt, adjust bearing. Unusual sounds coming from bearing may be symptoms of excess wear, dirt or damage. In such a case, the bearing and sealing ring should be replaced with new parts (if they are not suitable for further operation) or cleaned and greased again.



Check wheel axle bearings for slackness:

- after the first month of use,
- every 6 months of use.

Check condition of hub cover, if necessary replace with new cover. Inspection of bearing slackness may only be conducted when the trailer is hitched to tractor. The machine may not be loaded.



DANGER

Before commencing work the user must read the instructions for lifting and adhere to the manufacturer's instructions.

The lifting jack must be stably supported by the ground and so must the axle.

Ensure that trailer shall not move during inspection of bearing looseness of axles.

5.2.3 ADJUSTMENT OF PLAY OF WHEEL AXLE BEARINGS

- ➔ Take off hub cover (1), figure (5.3).
- ➔ Take out cotter pin (3) securing castellated nut (2).
- ➔ Tighten castellated nut in order to eliminate looseness.
 - ⇒ Wheel should rotate with insignificant resistance.
- ➔ Unscrew nut (not less than 1/3 rotation) to cover the nearest thread groove with alignment to opening in wheel stub axle. Wheel should rotate without excessive resistance.

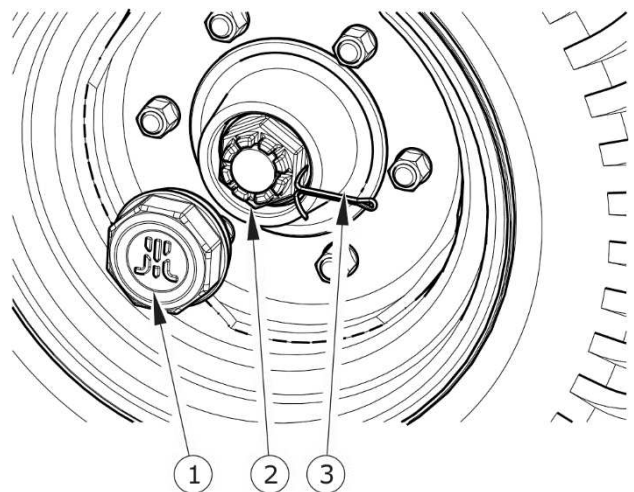

FIGURE 5.3 Adjustment of slackness

(1) hub cover, (2) castellated nut, (3) securing split cotter pin,

⇒ Nut may not be excessively tightened. Do not apply excessive pressure because working conditions of the bearings may deteriorate.

- ➔ Secure castellated nut with cotter pin and mount hub cap.
- ➔ Delicately tap hub cap with rubber or wooden hammer.

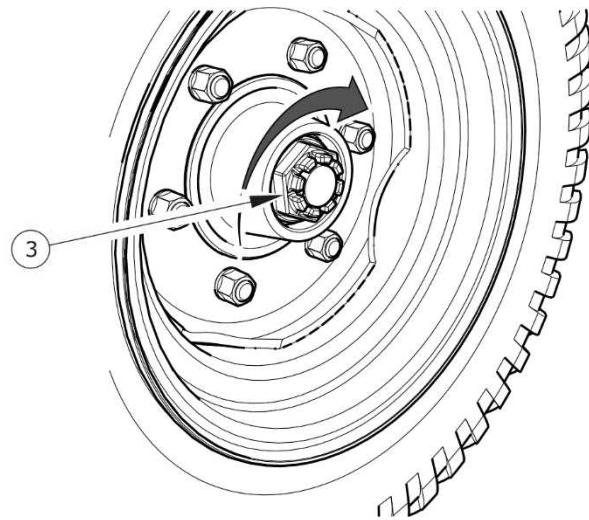

FIGURE 5.4 Tightening castellated nut

The wheel should turn smoothly without stiffness or detectable resistance. Adjustment of bearing slackness may only be conducted when the trailer is not loaded and hitched to the tractor.

5.2.4 MOUNTING AND DISMOUNTING WHEEL, INSPECTION OF WHEEL NUT TIGHTENING.

Wheel removal

- ➔ Place chocks under wheel that will not be dismantled.
- ➔ Ensure that trailer shall not move during wheel dismantling.
- ➔ Loosen wheel nuts according to the sequence shown in figure (5.5).
- ➔ Place lifting jack and lift trailer.
- ➔ Dismount wheel.

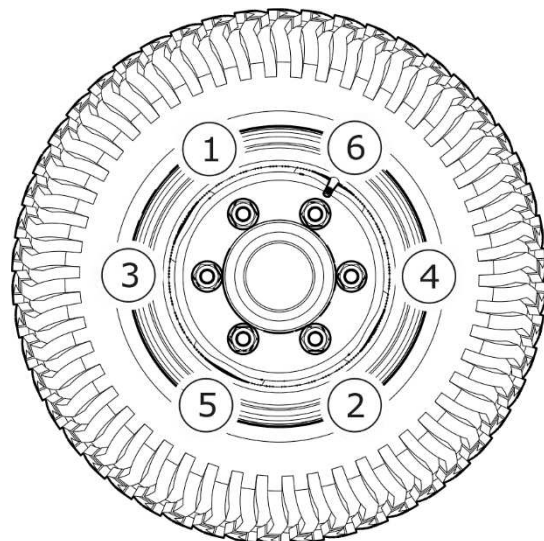

FIGURE 5.5 Sequence of undoing and tightening nuts

Wheel installation

- ➔ Clean axle pins and nuts of dirt contamination.
- ➔ Do not grease thread of nuts and pins.
- ➔ Check condition of pins and nuts, if necessary replace.
- ➔ Place wheel on hub, tighten nuts so that wheel rim tightly fits the hub.
- ➔ Lower trailer, tighten nuts according to recommended torque and given sequence.

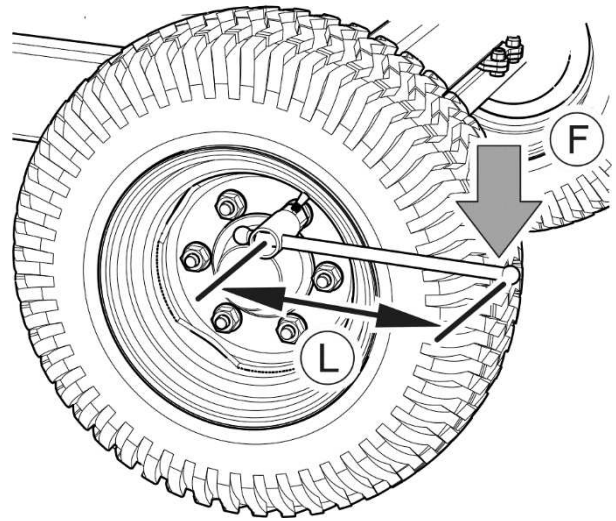

FIGURE 5.6 How to tighten a trailer wheel

(F) – weight of the person tightening the nut,

(L) - length of spanner arm

Tightening nuts

Nuts should be tightened gradually diagonally, (in several stages, until obtaining the required tightening torque) using a torque spanner. If a torque spanner is not available, one may use an ordinary spanner. The arm of the spanner (L) figure (5.5) should be selected according to the weight of the person (F) tightening the nut. Remember that this method of tightening is not as accurate as the use of a torque spanner.



TIP

Wheel nuts should be tightened using the torque of 270 Nm - M18x1.5 nuts.



Checking wheel tightening:

- after the first use of the trailer,
- after first travel with load,
- after travelling the first 1,000 km
- every six months use or every 25,000 km.

The above actions should be repeated individually if a wheel has been removed from the wheel axle.

TABLE 5.1 Selection of spanner arm length

WHEEL TIGHTENING TORQUE	BODY WEIGHT (F)	ARM LENGTH (L)
[NM]	[KG]	[M]
270	90	0.30
	77	0.35
	67	0.40
	60	0.45

IMPORTANT!



Axle nuts may not be tightened with impact wrench, because of danger of exceeding permissible tightening torque, the consequence of which may be breaking the thread connection or breaking off the hub pins.

The greatest precision is achieved using a torque spanner. Before commencing work, ensure that correct tightening torque value is set.

5.2.5 CHECKING AIR PRESSURE, EVALUATING THE TECHNICAL CONDITION OF TYRES AND STEEL RIMS

Tyre pressure should be checked each time after changing spare wheel and not less than every month. In the event of intensive use, air pressure in tyres should be checked more frequently. During this time trailer must be unloaded. Checking should be done before travelling when tyres are not heated, or after an extended period of parking.

**TIP**

Tyre pressure values are specified in information decal, placed on wheel or on the frame above machine wheel.

**DANGER**

Damaged tyres or wheels may be the cause of a serious accident.

While checking pressure pay attention to technical condition of wheels and tyres. Look carefully at tyre sides and check the condition of tread. In case of mechanical damage consult the nearest tyre service and check whether the tyre defect requires tyre replacement. Wheels should be inspected with regard to distortion, breaking of material, breaking of welds, corrosion, especially in the area of welds and contact with tyre. Proper technical condition and appropriate maintenance of wheels significantly extends the life of these components and ensures appropriate level of safety to trailer users.

**Checking tyre pressure and steel rims:**

- every month of use,
- every week during intensive work,
- if needed.

5.2.6 MECHANICAL BRAKES ADJUSTMENT

During trailer operation drum brake linings are subjected to wear. Piston stroke extends, and exceeding braking force limiting value declines.

Adjustment must be made when:

- piston stroke amounts to 2/3 of maximum stroke,
- expansion levers are not set in parallel to each other during braking,
- repairs are made to braking system.

Trailer wheels must brake simultaneously. Brakes adjustment involves changing the position of the expander arm (1), figure (5.4), in relation to expander shaft (2).

Required service actions

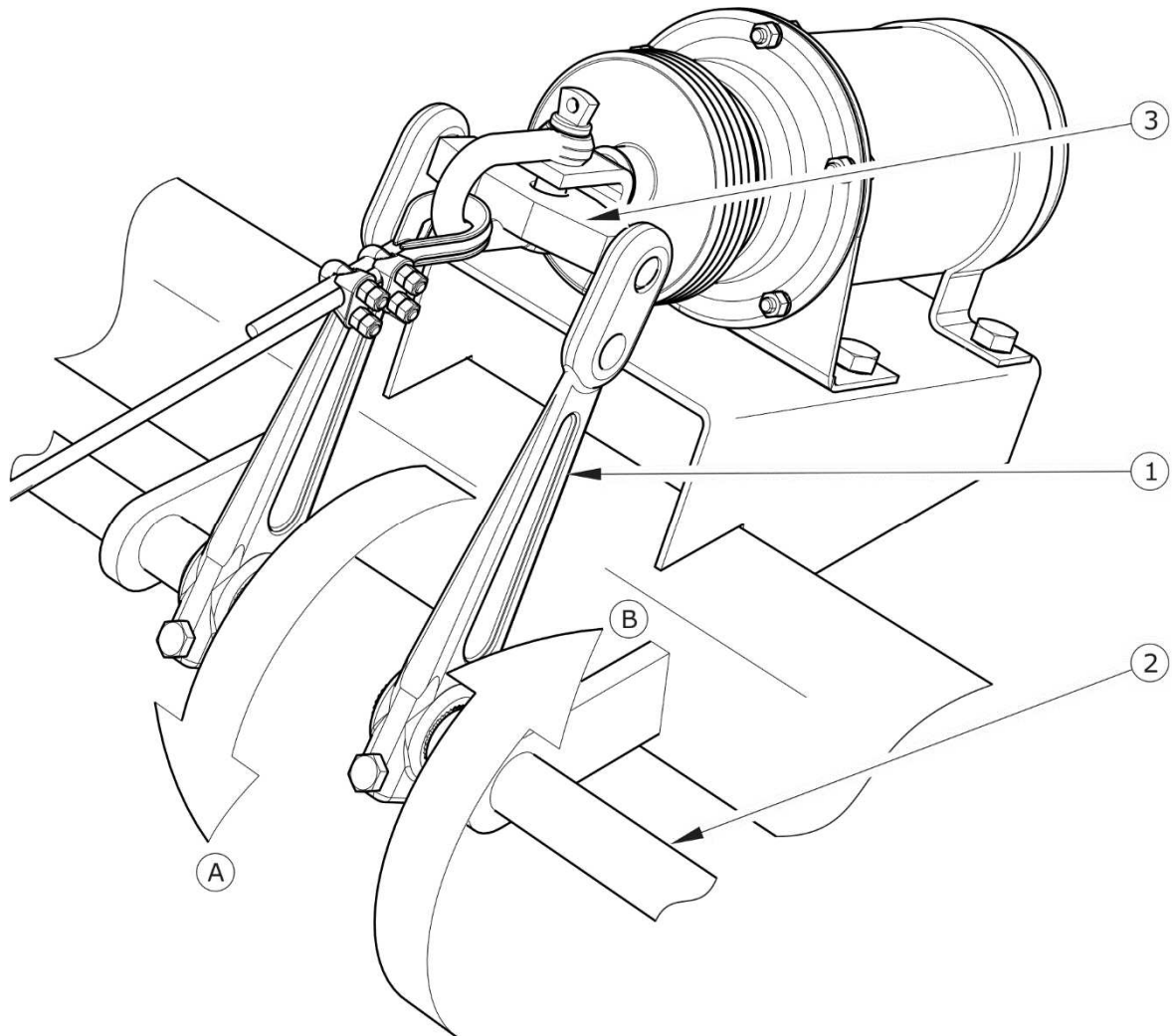

FIGURE 5.7 Adjustment of axle mechanical brakes

(1) expander arm, (2) expander shaft, (3) equalising bar

- ➔ Remove the shackle which fastens the cylinder fork to the equaliser bar (3) and the brake cable.
- ➔ Mark position of expander arm (1) with regard to the shaft (2).
- ➔ Dismantle arm and set it in the appropriate position.
 - ⇒ in direction (A), if braking is too early,
 - ⇒ in direction (B), if braking is too late.
- ➔ Repeat the process for the second arm.
- ➔ Fit the shackle and brake cable.

Adjustment should be conducted separately for each wheel. Expander arm (1) should be moved by one notch in chosen direction. If the extent of cylinder action is still incorrect, move the lever again. After proper brake adjustment, at full braking, the expander arms should create the angle of 90° with the cylinder piston, and the stroke should amount to approximately half the length of the total stroke of the piston. After brake release expander arms may not be supported on any structural elements, because too little withdrawal of a piston ram may cause abrasion of brake shoes in drum and result in overheating trailer brakes. Expander arms must be positioned in parallel with regard to each other at full braking. If this is not so, adjust the position of the lever, which has the longer stroke.

If it is necessary to dismantle the equalising bar, remember or mark its original position in the expander arms. The mounting position is selected by the Manufacturer and may not be changed.

5.2.7 CHANGE OF PARKING BRAKE CABLE AND ADJUSTMENT OF CABLE TENSION.

Proper operation of the parking brake is dependent on the effectiveness of the axle brake and the correct brake cable tension.

Replacing the parking brake cable

- ➔ Hitch trailer to tractor. Park trailer and tractor on level surface.
- ➔ Place chocks under trailer wheel.
- ➔ Loosen nuts (2) of cable clamps – figure (5.8).
- ➔ Dismantle cable.
- ➔ Grease the mechanism of the parking brake and pins of cable guide rollers – see section *TRAILER LUBRICATION*.
- ➔ Install new cable, adjust cable tension.

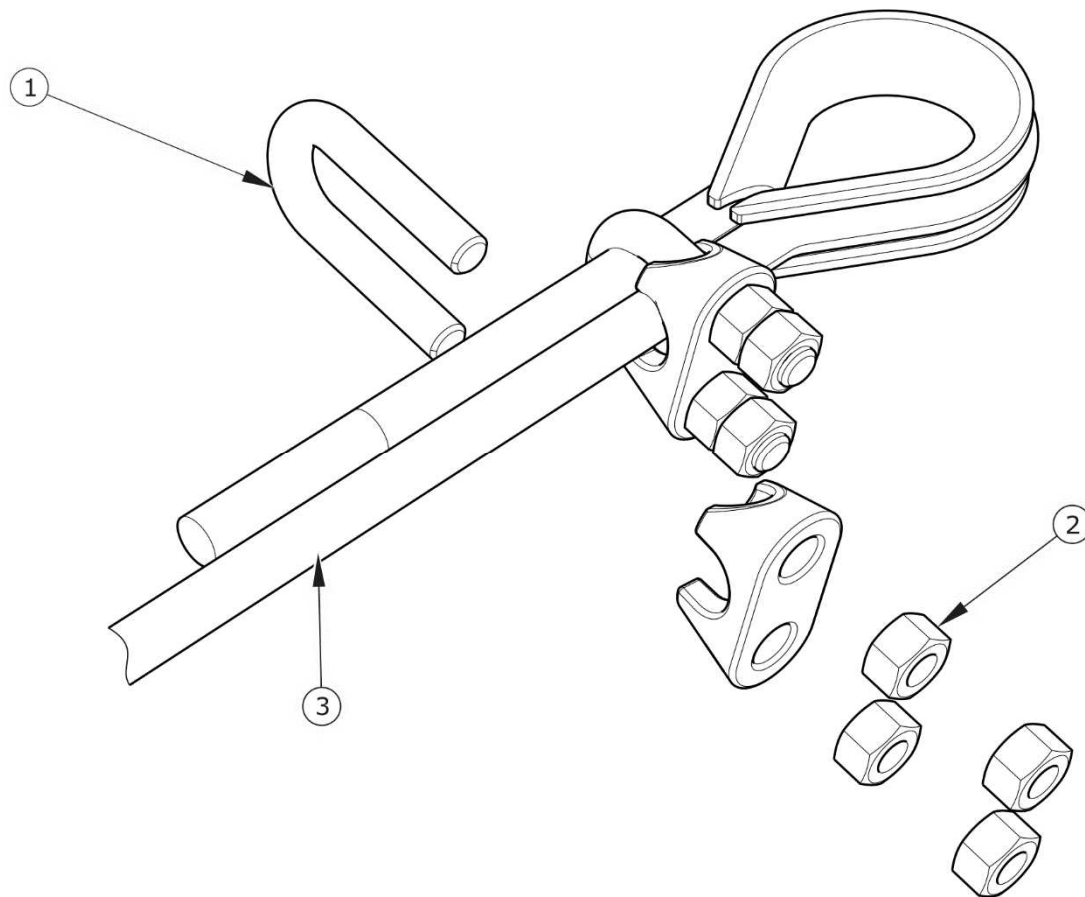

FIGURE 5.8 Installing the parking brake cable

(1) U-bolt clamp, (2) nuts of clamps, (3) handbrake cable

Adjustment of parking brake cable tension

- ➔ Hitch trailer to tractor. Park trailer and tractor on level surface.
- ➔ Place wheel chocks under trailer wheel.
- ➔ Fully unscrew the bolt of the handbrake mechanism.
- ➔ Loosen all nuts (2) of handbrake cable clamps on the brake mechanism side.
- ➔ Tighten cable and tighten clamps.
 - ⇒ Length of parking brake cable should be so selected that at total release of working and parking brake the cable would be loose and hanging by 1 - 2 cm.

**IMPORTANT!**

Parking brake cable clamps must be installed as shown in figure (5.8), i.e. clamp bracket (2) must be installed on the side of the shorter brake cable section. Tighten nuts using tightening torque given in table *TIGHTENING TORQUE FOR NUT AND BOLT CONNECTIONS*

Adjustment of parking brake cable tension should be conducted in the event of:

- stretching of cable,
- loosening of parking brake cable clamps
- after adjustment of axle brakes,
- after repairs to axle brake system,
- after repairs in parking brake system.

Before commencing adjustment make certain that the main brake is correctly regulated and is functioning properly.

**Checking and/or adjustment of parking brake:**

- every 12 months,
- if needed.

5.3 PNEUMATIC SYSTEM MAINTENANCE

5.3.1 PRELIMINARY INFORMATION

Work connected with the repair, change or regeneration of system components (brake cylinders, lines, control valve, braking force regulator etc.) should be entrusted to specialist establishments, having the appropriate technology and qualifications for this type of work.

The duties of the operator connected with the pneumatic system include:

- checking tightness and visual inspection of the system.
- cleaning the air filter (filters),
- draining water from air tank,

- cleaning drain valve,
- cleaning and maintaining pneumatic conduit connections,

**DANGER**

Do NOT use the trailer when brake system is unreliable.

5.3.2 CHECKING AIR TIGHTNESS AND VISUAL INSPECTION OF PNEUMATIC SYSTEM

Checking air tightness of pneumatic system

- ➔ Hitch trailer to tractor.
- ➔ Immobilise tractor and trailer with parking brake. Place chocks under trailer wheel.
- ➔ Start the tractor in order to supplement air in the trailer braking system tank.
 - ⇒ In single line systems air pressure should amount to approx. 5.8 to 6.5 bar.
 - ⇒ In double conduit systems air pressure should amount to approx. 5.8 bar.
- ➔ Turn off tractor engine.
- ➔ Check system components by releasing brake pedal in tractor.
 - ⇒ Give particular attention to conduit connections and brake cylinders.
- ➔ Repeat the system check with depressed tractor brake pedal.
 - ⇒ The help of a second person is required.

In the event of the appearance of leaks, compressed air will escape at the places of damage, with a characteristic hiss. Lack of system tightness may be exposed by covering checked elements with washing fluid or other foaming preparations, which will not react aggressively with system components. It is recommended to supply preparations commercially available designed to facilitate detecting air leaks. Damaged components should be replaced or

repaired. If leaks appear at connections then tighten the connections. If air continues to escape, replace connection component or seal.



Check system tightness

- after travelling the first 1,000 km,
- each time after making repairs or changing system components,
- annually.

Visual assessment of system

During tightness inspection attention should additionally be given to technical condition and degree of cleanness of the system components. Contact of pneumatic conduit seals etc. with oil, grease, petrol etc. may cause damage and accelerate the ageing process. Bent, permanently deformed, cut or worn conduits should be replaced.



Visual assessment of system

- after travelling the first 1,000 km,
- each time after making repairs or changing system components,
- annually.



IMPORTANT!

Repair, exchange or regeneration of pneumatic system components may only be performed in a specialised workshop.

5.3.3 CLEANING THE AIR FILTERS

Depending on trailer working conditions, but not less than once in three months, take out and clean air filter inserts, which are located in pneumatic system connection conduits. Inserts are used many times and are not subject to changing unless they are mechanically damaged.

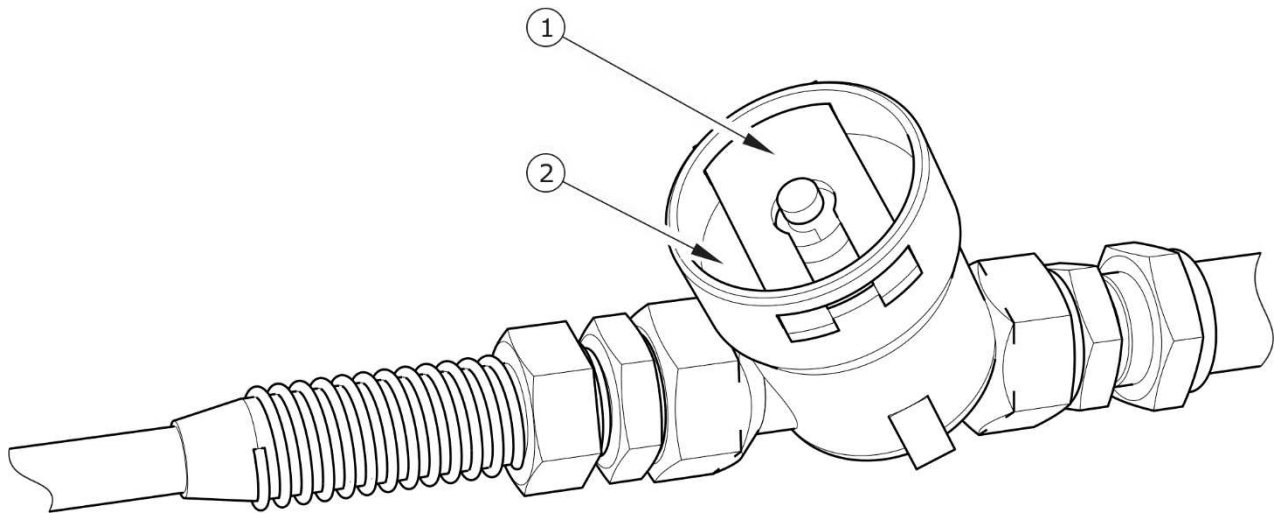

FIGURE 5.9 Air filter

(1) securing slide lock, (2) air filter cover



DANGER

Before proceeding to dismantle filter, reduce pressure in supply line. While disengaging filter slide gate, hold cover with other hand. Stand away from filter cover vertical direction.

Required service actions

- ➔ Reduce pressure in supply conduit.
 - ⇒ Pressure in conduit can be reduced by pressing the head of the pneumatic connection until resistance is felt.
- ➔ Remove securing slide (1).
 - ⇒ Hold the filter cover (2) with the other hand. After removing slide lock, the cover is pushed off by the spring, in the filter housing.
- ➔ The insert and the filter body should be carefully washed out and blown through with compressed air. Assembly should be done in reverse order.



Cleaning the air filter (filters):

- every 3 months of use,

5.3.4 DRAINING WATER FROM AIR TANK

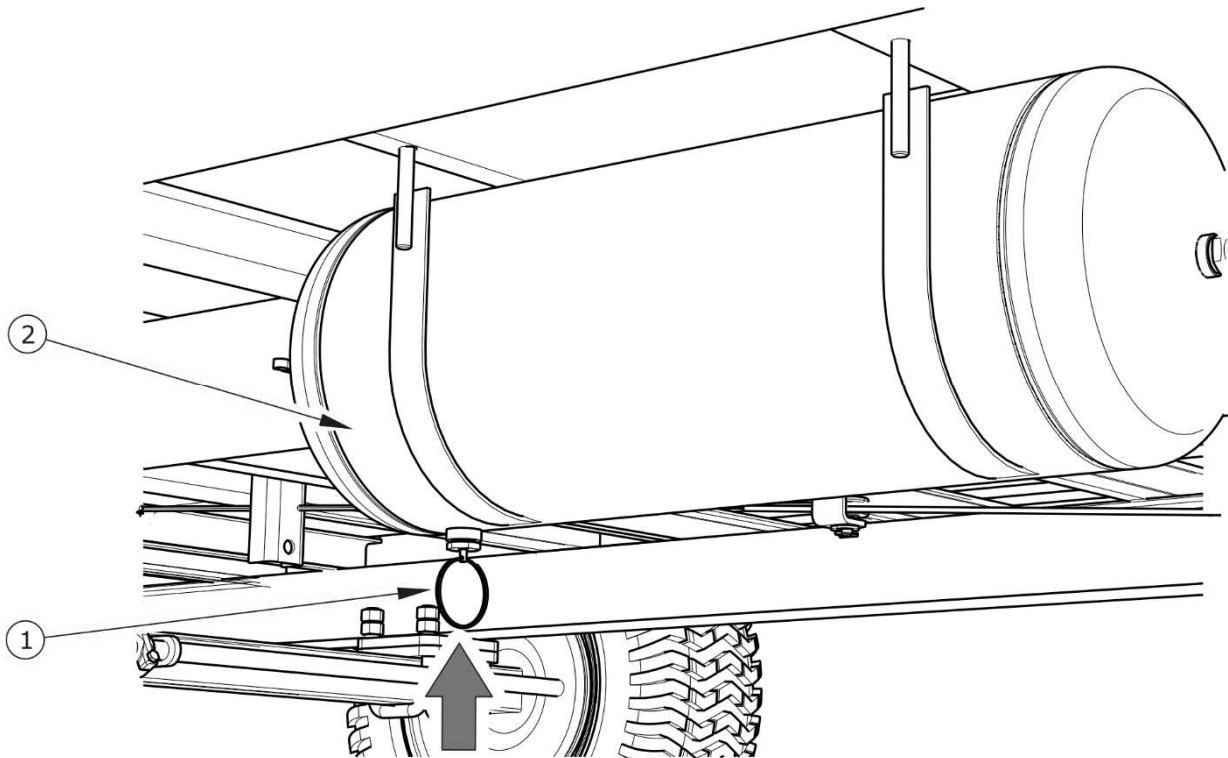

FIGURE 5.10 Draining water from air tank

(1) drain valve, (2) air tank

Required service actions

- ➔ Tilt the stem of drain valve (1) placed in lower part of tank (2) – the tank is placed under right longitudinal member of lower frame.
 - ⇒ The compressed air in the tank causes the removal of water to the exterior.
- ➔ Released valve stem should automatically close and stop flow of air from the tank.
 - ⇒ In the event, that the valve stem resists returning to its setting, then the whole drain valve must be unscrewed and cleaned, or replaced (if it is damaged).

**Draining water from air tank:**

- every seven days of use.

5.3.5 CLEANING DRAIN VALVE

**DANGER**

Release air from tank before dismantling drain valve.

Required maintenance activities

- ➔ Reduce pressure in air tank.
 - ⇒ Reduction of pressure in tank is achieved by tilting the drain valve stem.
- ➔ Unscrew valve.
- ➔ Clean valve, purge with compressed air.
- ➔ Change copper seal.
- ➔ Screw in valve, fill air tank, and check tank tightness.

**Cleaning valve:**

- every 12 months (before winter period).

5.3.6 CLEANING AND MAINTAINING PNEUMATIC LINE CONNECTIONS AND PNEUMATIC SOCKETS

**DANGER**

Unreliable and dirty trailer connections may cause unreliability and faulty functioning of braking system.

Connection with damaged body should be replaced. In event of damage to cover or seal, change these elements for new reliable elements. Contact of pneumatic connector seals with oils, grease, petrol etc. may cause damage and accelerate ageing process.

If the trailer is unhitched from the tractor, connections should be protected by cover or placed in their designated socket. Before the winter period it is recommended to preserve the seal with special preparations (e.g. silicon grease for rubber elements).

Each time before connection of the machine inspect technical condition and cleanness of contacts and sockets in tractor. If necessary, clean or repair tractor sockets.



Checking technical condition of connections:

- each time before hitching to tractor.

5.4 HYDRAULIC SYSTEM MAINTENANCE

5.4.1 PRELIMINARY INFORMATION

Work connected with the repair, change or regeneration of hydraulic system components (hydraulic brake system) should be entrusted to specialist establishments, having the appropriate technology and qualifications for this type of work.



TIP

Bleeding of the hydraulic system is not required during normal operation of the trailer.

The duties of the operator connected with the hydraulic system include:

- checking tightness and visual inspection of the system,
- checking technical condition of hydraulic connections.

5.4.2 CHECKING HYDRAULIC SYSTEM TIGHTNESS

Required service actions

- ➔ Hitch trailer to tractor.

- ➔ Connect all hydraulic system lines according to service instructions.
- ➔ Clean connectors and hydraulic cylinders.
- ➔ Start the tractor and depress brake pedal several times.
- ➔ Check tightness of hydraulic cylinders and conduits.

In the event of confirmation of oil on hydraulic ram cylinder bodies ascertain origin of leak. Inspect hydraulic seals when ram cylinders are completely extended. Minimum leaks are permissible with symptoms of "sweating", however in the event of noticing leaks in the form of "droplets" stop using the trailer until faults are remedied. If leaks appear at connections then tighten the connections.

**Checking tightness:**

- after the first week of use,
- every 12 months of use.

5.4.3 CHECKING TECHNICAL CONDITION OF HYDRAULIC CONNECTIONS AND SOCKETS.

Hydraulic connections must be technically reliable and kept in a clean condition. Each time before connecting, check if sockets in tractor are maintained in good working condition. Hydraulic systems of the tractor and trailer are sensitive to the presence of permanent contamination, which may cause damage to precision system components.



Inspection of hydraulic connections and sockets:

- each time before hitching trailer to tractor.

5.4.4 REPLACEMENT OF HYDRAULIC CONDUITS

Rubber hydraulic conduits must be replaced every 4 years regardless of their technical condition. This should be entrusted to specialised workshops.



Replacement of hydraulic conduits:

- every 4 years.

5.5 TRAILER LUBRICATION

Trailer lubrication should be performed with the aid of a manually or foot operated grease gun, filled with recommended grease. Before commencing work insofar as is possible remove old grease and other contamination. Remove and wipe off excess oil or grease.

Change of grease in hub bearings should be entrusted to specialised service points, equipped with the appropriate tools. According to the recommendations of the axle Manufacturer, dismantle the entire hub, remove the bearing and individual sealing rings. After careful washing and inspection, mount lubricated elements. If necessary, bearing and seals should be replaced with new parts. Lubrication of axle bearings shall be performed at least once in 2 years.

Empty grease or oil containers should be disposed of according to the recommendations of the lubricant Manufacturer.

TABLE 5.2 Trailer lubrication schedule

ITEM	LUBRICATION POINT	NUMBER OF LUBRICATION POINTS	TYPE OF GREASE	FREQUENCY
1	Hub bearing	4	A	24M
2	Drawbar eye	1	B	14D
3	Rotating drawbar eye	1	B	1M
3	Handbrake mechanism	1	A	6M
4	Handbrake roller axle	1	A	6M
5	Hinges of tailgate, side doors and partition	8 - 10	A	6M
6	Support screw	1	A	3M
7	Overrun drawbar components	1	A	3M

Lubrication periods – M months, D – days

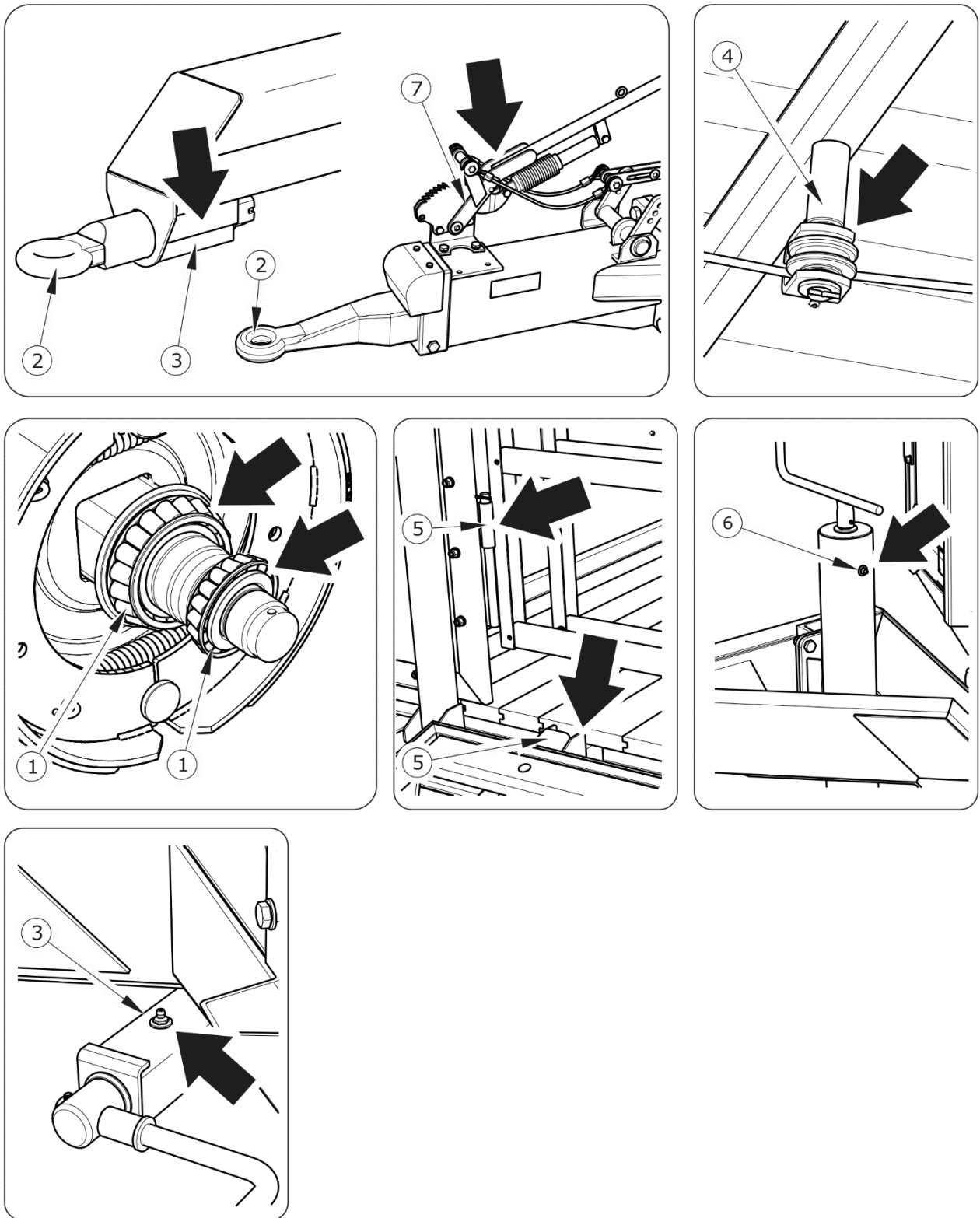



FIGURE 5.11 Trailer's lubrication points

TABLE 5.3 Recommended lubricants

MARKING ACCORDING TO TAB. (5.2)	DESCRIPTION
A	machine general-purpose grease (lithium, alkaline),
B	permanent grease for heavily loaded elements with addition of MOS ₂ or graphite

Number of lubrication points and subassemblies requiring lubrication depend on equipment of the trailer.



During trailer use the user is obliged to observe lubrication instructions according to attached lubrication schedule.

5.6 CONSUMABLES

5.6.1 HUDRAULIC OIL (HYDRAULIC BRAKE SYSTEM)

TABLE 5.4 L-HL 32 Lotos hydraulic oil characteristics

ITEM	NAME	UNIT	VALUE
1	ISO 3448VG viscosity classification	-	32
2	Kinematic viscosity at 40°C	mm ² /s	28.8 – 35.2
3	ISO 6743/99 quality classification	-	HL
4	DIN 51502 quality classification	-	HL
5	Flash-point	C	230

Always adhere to the principle that the oil in the trailer hydraulic system and in the tractor hydraulic system are of the same type. In the event of application of different types of oil make certain that both hydraulic substances may be mixed together. Application of different oil types may cause damage to trailer or tractor. In a new machine, the hydraulic system is filled with L HL32 Lotos hydraulic oil.

In the event of necessity of changing hydraulic oil for another oil, check the recommendations of the oil Manufacturer very carefully. If it is recommended to flush the system with the appropriate preparation, then comply with these recommendations. Attention should be given, so that chemical substances used for this purpose do not damage the materials of the hydraulic system. During normal trailer use, change of hydraulic oil is not necessary, but if required, this operation should be entrusted to a specialist service point.

Because of its composition the oil applied is not classified as a dangerous substance, however long-term action on the skin or eyes may cause irritation. In the event of contact of oil with skin wash the place of contact with water and soap. Do NOT apply organic solvents (petrol, kerosene). Contaminated clothing should be changed to prevent access of oil to skin. In the event of contact of oil with eye, rinse with large quantity of water and in the event of the occurrence of irritation consult a doctor. Hydraulic oil in normal conditions is not harmful to the respiratory tract. A hazard only occurs when oil is strongly atomised (oil vapour), or in the case of fire during which toxic compounds may be released.

**DANGER**

Oil fires should be quenched with the use of carbon dioxide, foam or extinguisher steam. Do not use water to quench oil fires.

5.6.2 LUBRICANTS

For parts under great load it is recommended to apply lithium grease with molybdenum disulphide (MOS_2) or graphite additive. In the case of less loaded sub-assemblies the application of general purpose machine greases is recommended, which contain anticorrosion additive and have significant resistance to being washed away by water. Similar characteristics should typify aerosol preparations (Silicon greases and anticorrosive lubricant substances).

Before starting to use greases acquaint oneself with the content of the information leaflet for the chosen product. Particularly relevant are safety rules and handling procedures for given lubricant product and waste utilisation (used containers, contaminated rags etc.). Information leaflet (material safety data sheet) should be kept together with grease.

5.7 TRAILER CLEANING

The load box should be cleaned after every use and during a longer down-time. Other components should be cleaned as needed. Before using pressure washer the user is obliged to acquaint himself with the operating principles and recommendations concerning safe use of this equipment.

Trailer cleaning guidelines

- Before cleaning, open the tailgate of the load box and open the drain valve (for a undercarriage with a steel floor). Remove carefully any dirt from the load box floor.
- To wash the inside of the load, use clean running water only; in other cases you may use water with a cleaning detergent with neutral pH.
- Using pressure washer increases washing effectiveness, but particular care must be taken during work. During washing, washer nozzle may not be closer than 50 cm from the surface being cleaned.
- Water temperature shall not exceed 55°C.
- Do not direct water stream directly at system elements and equipment of the trailer i.e. control valve, braking force regulator, brake cylinders, pneumatic, electric and hydraulic plugs, lights, electrical connections, information and warning decals, identification plate, conduit connections and lubrication points etc. Great water jet pressure may damage these elements. You may wash plywood or wood surfaces and bituminous screed with water only if using low pressure of water.
- For cleaning and maintenance of plastic coated surfaces it is recommended to use clean water or special preparations designed for this purpose.
- Do not apply organic solvents, preparations of unknown origin or other substances, which may cause damage to lacquered, rubber or plastic surfaces. In the event of doubt it is recommended to make a test on an unseen surface area.

- Surfaces smeared with oil or grease should be cleaned by application of benzene or other degreasing agents and then washed with clean water with added detergent. Comply with recommendations of the Manufacturer.
- Washing detergent should be kept in original containers, optionally in replacement containers, but very clearly marked. Preparations may not be stored in food and drink containers.



DANGER

Carefully read the instructions for application of washing detergents and maintenance preparations.

While washing with detergents wear appropriate protective clothing and goggles protecting against splashing.

- Unsure cleanliness of elastic conduits and seals. The plastic from which these elements are made may be susceptible to organic substances and some detergents. As a result of long-term reaction of some substances, the ageing process may be accelerated and risk of damage increased. Rubber elements should be maintained with the aid of special preparations after previous thorough washing.
- Observe environmental protection principles and wash trailer in a place designed for this purpose.
- Washing and drying trailer must take place at temperatures above 0°C.

5.8 STORAGE

- Trailer should be kept in a closed or roofed building.
- If the machine will not be used for a long time, it is essential to protect it from adverse weather, especially rust and accelerated tyre deterioration. During this time the machine must be unloaded. Trailer should be very carefully washed and dried.
- Corroded places should be cleaned of rust, degreased and protected using undercoat paint and then painted with surface paint according to colour scheme.

- Protect wooden floors with an impregnant once a year.
- In the event of prolonged work stoppage, it is essential to lubricate all elements regardless of the period of the last lubrication process.
- Wheel rims and tyres should be carefully washed and dried. During longer storage of unused trailer it is recommended that every 2 to 3 weeks the machine may be moved a bit so that the place of contact of tyres with ground is changed. The tyres will not be deformed and maintain proper geometry. Also tyre pressure should be inspected from time to time, and if necessary pressure should be increased to appropriate value.

5.9 TIGHTENING TORQUE FOR NUT AND BOLT CONNECTIONS

Unless other tightening parameters are given, during maintenance repair work apply appropriate torque to tightening nut and bolt connections. Recommended tightening torque values for the most frequently used bolt and nut connections are given in table (5.5). Given values apply to non-lubricated steel bolts.

TABLE 5.5 Tightening torque for nut and bolt connections

THREAD METRIC	5.8 ⁽¹⁾	8.8 ⁽¹⁾	10.9 ⁽¹⁾
	Md [Nm]		
M10	37	49	72
M12	64	85	125
M14	100	135	200
M16	160	210	310
M20	300	425	610
M24	530	730	1,050
M27	820	1,150	1,650
M30	1,050	1,450	2,100

⁽¹⁾ – resistance class according to DIN ISO 898 standard

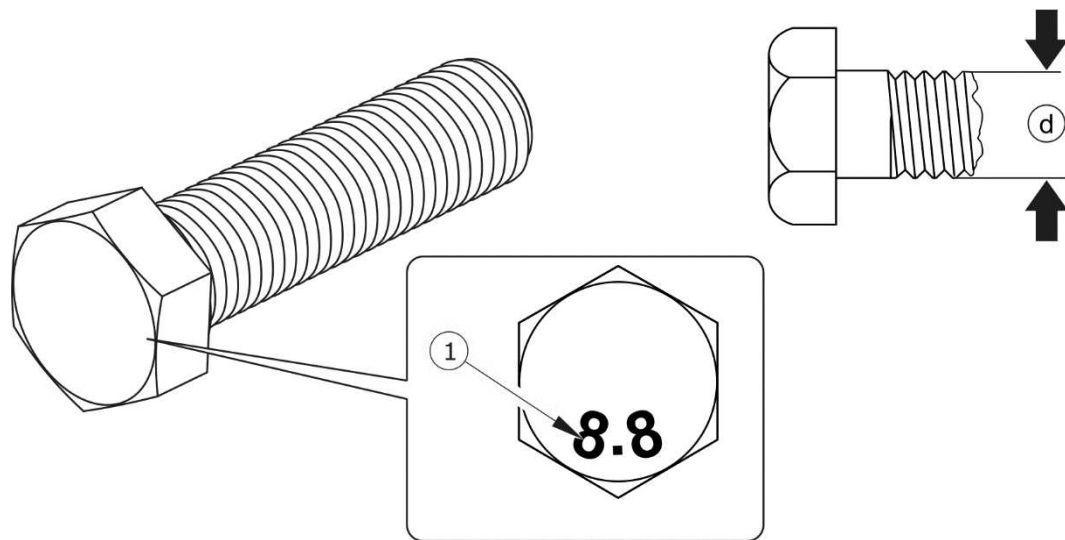

FIGURE 5.12 Bolt with metric thread

(1) resistance class, (d) thread diameter



TIP

Hydraulic conduits should be tightened using torque of 50 – 70 Nm.

5.10 TROUBLESHOOTING

TABLE 5.6 Troubleshooting

FAULT	CAUSE	REMEDY
Problem with moving off	Brake system conduits not connected	Connect brake conduits (applies to pneumatic systems)
	Applied parking brake	Release parking brake.
	Damaged pneumatic system connection conduits	Replace.
	Leaking connections	Tighten, replace washers or seal sets, replace conduits.
	Control valve or braking force regulator damaged	Check valve, repair or replace.

FAULT	CAUSE	REMEDY
Noise in axle hubs	Excessive bearing slackness	Check slackness and adjust if needed
	Damaged bearing	Replace bearing
	Damaged hub parts	Replace
Poor reliability of braking system	Insufficient pressure in system	<p>Check pressure on tractor pressure gauge, wait till compressor fills tank to required pressure.</p> <p>Damaged air compressor in tractor Repair or replace.</p> <p>Damaged brake valve in tractor. Repair or replace.</p> <p>Leaking system conduits or connections. Check system for tightness.</p>
Excessive heating of axle hubs	Incorrect main or parking brake adjustment	Regulate setting of expander arms
	Worn brake linings	Change brake shoes
Incorrect hydraulic system operation	Improper hydraulic oil viscosity	Check oil quality, make sure that the oil in both machines is of the same type. If necessary change oil in tractor or in trailer
	Insufficient tractor hydraulic pump output, tractor hydraulic pump is damaged	Check tractor hydraulic pump.
	Damaged or contaminated ram cylinder	Check cylinder ram piston (bending, corrosion), check ram cylinder for tightness (piston seal), in case of need repair or replace ram cylinder.
	Excessive cylinder ram loading	Check and reduce cylinder loading if necessary
	Damaged hydraulic conduits	Check and ascertain that hydraulic conduits are tight, not fractured and properly tightened. If necessary replace or tighten.

NOTES

A series of horizontal dotted lines for writing notes.



ANNEX A

Wheels of wheel axles

TYRES	WHEEL DISC
11.5/80-15.3 14PR	9.00x15.3"
14.0/65-16 14PR	11x16" ET=0
400/60 - 15.5 14PR	13.00x15.5" ET=-15