Thank you for purchasing our trailer. In the interests of your safety and care for the reliability and durability of the machine, we ask that you familiarise yourself with the content of this manual.

Remember!!!

Before using the trailer for the first time, check if the wheels are properly tightened!!! Regularly check the technical condition of the machine in accordance with the attached schedule.

INTRODUCTION

Information contained herein is current at date of publication. As a result of improvements, some numerical values and illustrations contained in this publication may not correspond to the factual specification of the machine supplied to the user. The manufacturer reserves the right to introduce design changes in machines produced that facilitate operation and improve the quality of their work, without making minor amendments to this Operator's Manual. Please send your comments and proposals on the design and operation of the machine to the Manufacturer. This information enables objective evaluation of the machines produced and provides indications for their further improvement. Information on significant design changes is passed on to users on information inserts attached to this Operator's Manual (annexes).

This Operator's Manual is an integral part of the machine's documentation. Before using the machine, the user must carefully read this Operator's Manual and observe all recommendations. This guarantees safe operation and ensures malfunction free work of the machine. The machine is designed to meet obligatory standards, documents and legal regulations currently in force.

The manual describes the basic safety rules and operation of agricultural trailer Pronar T024. If the information contained in the Operator's Manual needs clarification then the user should refer for assistance to the sale point where the machine was purchased or to the Manufacturer.

Manufacturer's address:

PRONAR Sp. z o.o.

ul. Mickiewicza 101A

17-210 Narew

Contact telephones

+48 085 681 63 29 +48 085 681 64 29

+48 085 681 63 81 +48 085 681 63 82

Symbols appearing in this Operator's Manual

Information, descriptions of danger and precautions and also recommendations and prohibitions associated with user safety instructions are marked:



and also preceded by the word "**DANGER**". Failure to observe the instructions may endanger the machine operator's or other person's health or life.

Particularly important information and instructions, the observance of which is essential, are distinguished in the text by the sign:



and also preceded by the word "**ATTENTION**". Failure to observe the instructions may lead to damage to the machine as a result of improper operation, adjustment or use.

In order to focus the user's attention on the need to perform maintenance, the relevant section of the Operator's Manual is marked with the pictogram:



Additional tips and advice for machine operation are marked:



and also preceded by the word „**TIP**”.

Directions used in this Operator's Manual

Left side – side to the left hand of the operator facing in the direction of machine's forward travel.

Right side – side to the right hand of the operator facing in the direction of machine's forward travel.

Required service actions

Service actions described in the manual are marked: ⇨

Results of service/adjustment actions are marked: ➡



PRONAR Sp. z o.o.

ul. Mickiewicza 101 A
17-210 Narew, Polska

tel./fax (+48 85) 681 63 29, 681 63 81, 681 63 82,
681 63 84, 681 64 29

fax (+48 85) 681 63 83

<http://www.pronar.pl>

e-mail: pronar@pronar.pl

EC DECLARATION OF CONFORMITY OF THE MACHINERY

PRONAR Sp. z o.o. declares with full responsibility, that the machine:

Description and identification of the machinery	
Generic denomination and function:	AGRICULTURAL TRAILER
Type:	T024
Model:	—
Serial number:	
Commercial name:	AGRICULTURAL TRAILER PRONAR T024 AGRICULTURAL TRAILER PRONAR T024M

to which this declaration relates, fulfills all the relevant provisions of the Directive **2006/42/EC** of The European Parliament and of The Council of 17 May 2006 on machinery, and amending Directive 95/16/EC (Official Journal of the EU, L 157/24 of 09.06.2006).

The person authorized to compile the technical file is the Head of Research and Development Department at PRONAR Sp. z o.o., 17-210 Narew, ul. Mickiewicza 101A, Poland.

This declaration relates exclusively to the machinery in the state in which it was placed on the market, and excludes components which are added and/or operations carried out subsequently by the final user.

Narew, the 2014 -08- 2 8

Place and date

[Signature]
Full name of the empowered person
position, signature

TABLE OF CONTENTS

1	BASIC INFORMATION	1.1
1.1	IDENTIFICATION	1.2
1.1.1	TRAILER IDENTIFICATION	1.2
1.1.2	AXLE IDENTIFICATION	1.4
1.1.3	LIST OF SERIAL NUMBERS	1.4
1.2	INTENDED USE	1.5
1.3	ACCESSORIES	1.7
1.4	WARRANTY TERMS & CONDITIONS	1.9
1.5	TRANSPORTATION	1.10
1.5.1	TRANSPORT ON VEHICLE	1.10
1.5.2	INDEPENDENT TRANSPORT BY THE USER	1.12
1.6	ENVIRONMENTAL HAZARDS	1.12
1.7	DISPOSAL	1.14
2	USER'S SAFETY	2.1
2.1	SAFETY ADVICE	2.2
2.1.1	BASIC SAFETY RULES	2.2
2.1.2	RULES OF USING PUBLIC ROADS	2.6
2.1.3	RESIDUAL RISK DESCRIPTION	2.7
2.2	WARNING & INFORMARION LABELS	2.8
3	DESIGN AND OPERATION	3.1
3.1	TECHNICAL SPECIFICATION	3.3
3.2	TRAILER DESIGN	3.4

3.2.1	CHASSIS	3.4
3.2.2	SIDE UNDER-RUN PROTECTION DEVICES	3.5
3.2.3	MAIN BRAKE	3.6
3.2.4	PARKING BRAKE	3.10
3.2.5	ELECTRIC LIGHTING SYSTEM	3.11
3.2.6	HYDRAULIC SYSTEM OF SHEAR TYPE DRAWBAR SUPPORT	3.13

4 CORRECT USE 4.1

4.1	PREPARING THE TRAILER FOR WORK	4.3
4.1.1	PRELIMINARY INFORMATION	4.3
4.1.2	HAND-OVER AND INSPECTION OF THE MACHINE AFTER DELIVERY	4.3
4.1.3	PREPARING THE TRAILER FOR THE FIRST USE, TEST RUN OF THE TRAILER	4.4
4.1.4	PREPARING THE TRAILER FOR NORMAL USE	4.5
4.2	LOADING AND SECURING LOAD	4.9
4.2.1	GENERAL INFORMATION ABOUT LOADING	4.9
4.2.2	SECURING LOAD	4.10
4.2.3	TENSIONER OPERATION	4.11
4.3	LOAD TRANSPORT	4.11
4.4	UNLOADING	4.13
4.5	PROPER USE AND MAINTENANCE OF TYRES	4.14

5 MAINTENANCE 5.1

5.1	PRELIMINARY INFORMATION	5.3
5.2	SERVICING WHEEL AXLE	5.3
5.2.1	PRELIMINARY INFORMATION	5.3
5.2.2	CHECKING WHEEL AXLE BEARINGS FOR SLACKNESS	5.4
5.2.3	ADJUSTMENT OF PLAY OF WHEEL AXLE BEARINGS	5.6

5.2.4	MOUNTING AND DISMOUNTING WHEEL, INSPECTION OF WHEEL NUT TIGHTENING	5.7
5.2.5	CHECKING AIR PRESSURE IN TYRES, EVALUATING TECHNICAL CONDITION OF TYRES AND STEEL WHEELS	5.9
5.2.6	CHECKING THICKNESS OF BRAKE SHOE LININGS.	5.10
5.2.7	ADJUSTMENT OF MECHANICAL BRAKES	5.11
5.2.8	REPLACEMENT OF PARKING BRAKE CABLE AND ADJUSTMENT OF CABLE TENSION.	5.15
5.3	PNEUMATIC SYSTEM MAINTENANCE	5.18
5.3.1	PRELIMINARY INFORMATION	5.18
5.3.2	CHECKING TIGHTNESS	5.18
5.3.3	INSPECTION OF THE SYSTEM	5.19
5.4	CLEANING THE AIR FILTERS	5.20
5.4.1	DRAINING WATER FROM AIR TANK	5.21
5.4.2	CLEANING DRAIN VALVE	5.21
5.4.3	CLEANING AND MAINTAINING PNEUMATIC CONDUIT CONNECTIONS AND PNEUMATIC SOCKETS	5.22
5.5	HYDRAULIC SYSTEM MAINTENANCE	5.23
5.5.1	PRELIMINARY INFORMATION	5.23
5.5.2	CHECKING HYDRAULIC SYSTEM TIGHTNESS	5.23
5.5.3	CHECKING TECHNICAL CONDITION OF HYDRAULIC COUPLERS AND SOCKETS.	5.24
5.5.4	REPLACEMENT OF HYDRAULIC CONDUITS	5.24
5.6	LUBRICATION	5.25
5.6.1	CONSUMABLES	5.28
5.7	TRAILER CLEANING	5.29
5.8	STORAGE	5.31
5.9	INSPECTION OF TIGHTENING TORQUE OF NUT AND BOLT CONNECTIONS	5.32
5.9.1	TIGHTENING TORQUE FOR NUT AND BOLT CONNECTIONS	5.32
5.10	ADJUSTMENT OF DRAWBAR POSITION	5.33

5.11 TROUBLESHOOTING

5.35

5.11.1 TROUBLESHOOTING

5.35

SECTION

1

BASIC INFORMATION

1.1 IDENTIFICATION

1.1.1 TRAILER IDENTIFICATION

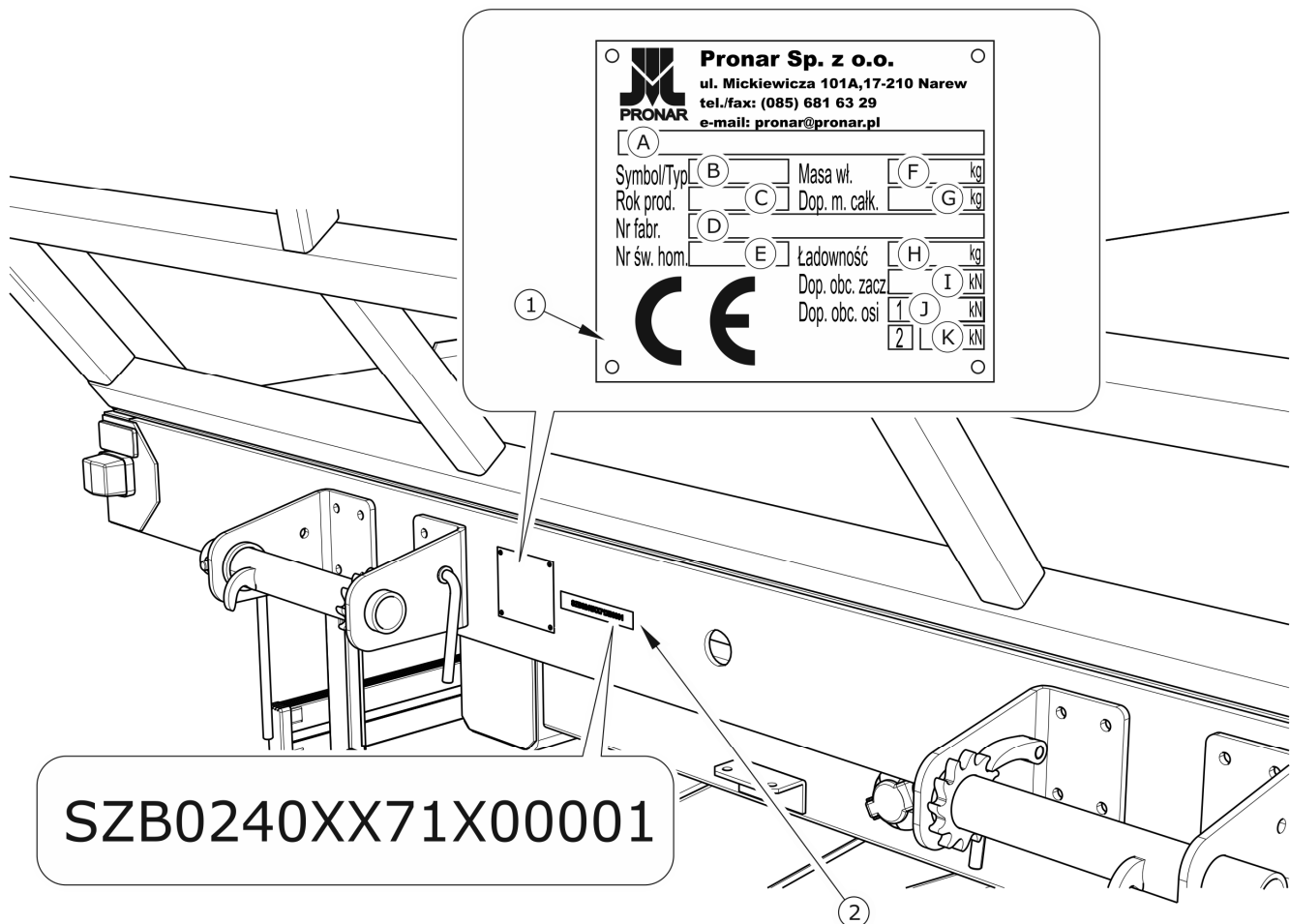

FIGURE 1.1 Location of the data plate and vehicle identification number (VIN)

(1) data plate, (2) example of vehicle identification number (VIN)

Pronar T024, T024M agricultural trailers are marked with the data plate (1) and vehicle identification number (VIN) (2). The serial number and data plate are located in the central part of the frame front beam – figure (1.1). When buying the agricultural trailer check that the serial numbers on the machine agree with the number written in the WARRANTY BOOK and in the sales documents.

Serial number of the traction axis and their type are imprinted on the data plate installed on the traction axle beam. The meaning of the individual fields found on the data plate are presented in the table below:

TABLE 1.1 *Markings on data plate*

ITEM	MARKING
A	General description and purpose
B	Symbol /Type
C	Year of manufacture
D	Seventeen digit serial number (VIN)
E	Official certificate number
F	Tare weight
G	Maximum gross weight
H	Carrying capacity
I	Maximum hitch load (not applicable)
J	Permissible front axle load
K	Permissible rear axle load

1.1.2 AXLE IDENTIFICATION

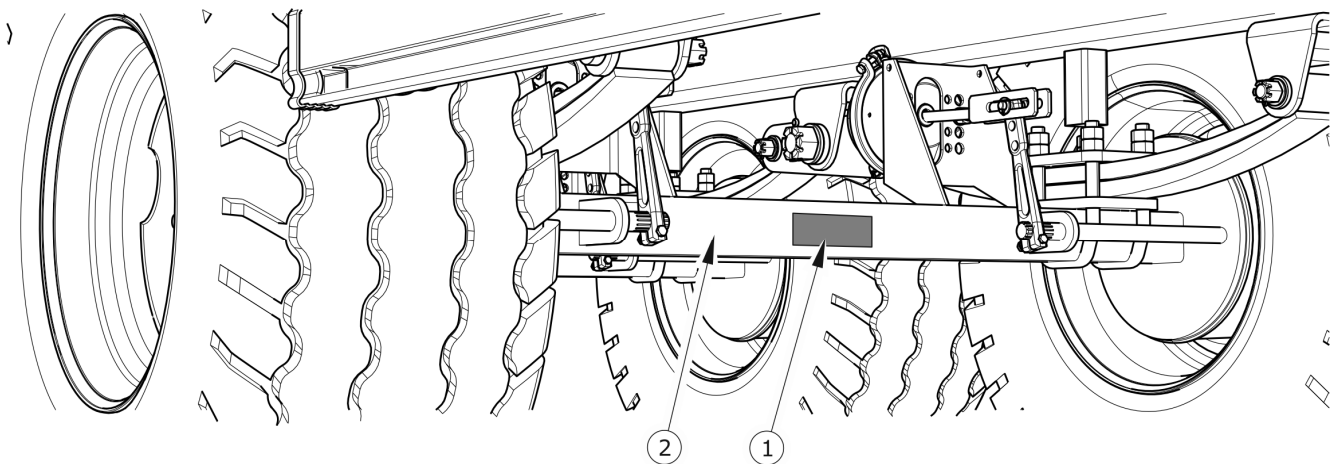

FIGURE 1.2 Location of the axle data plate

(1) data plate, (2) wheel axle

The serial number of the wheel axle and its type are stamped onto the data plate (2) secured to the wheel axle beam (1) – figure (1.2).

1.1.3 LIST OF SERIAL NUMBERS

TABLE 1.2 Recommended Pallet Type

VIN NUMBER													
Z	B	0	2	5	0		X			X			
SERIAL NUMBER OF FRONT AXLE													
SERIAL NUMBER OF REAR AXLE													



TIP

In the event of ordering a replacement part or in the case of the appearance of problems it is often essential to give the serial number of the agricultural trailer or the serial number of the axles, therefore it is recommended that these numbers are inscribed in the table (1.2).

1.2 INTENDED USE

Bale transport trailer is used for transporting agricultural products and commodities prepared in form of bales or pressed blocks within a farm area and on public roads. The machine is also designed for transporting harvested crops and agricultural products on EUR-pallets and in pallet boxes.

The transport of the above-mentioned harvested crops and agricultural products is permitted provided that the recommendations included in this manual, especially the recommendations concerning protection of loads included in Section (4.3.2), are adhered to.

The trailer may only be hitched to the agricultural tractors which fulfil all the requirements specified in table (1.4).

TABLE 1.3 *Recommended Pallet Type*

PALLET NAME – TYPE	LENGHT [mm]	WIDTH [mm]	HEIGHT [mm]
Euro pallet – standard	1 200	800	144
Euro pallet – 1/2	800	600	144
Euro pallet – extended	1 200	1 200	144
ISO Pallet	1 200	1 000	144

Braking, signaling and lighting systems are compliant with traffic regulations. Do NOT exceed the permissible speed of the tractor-trailer combination (the permissible speed in force in the country in which the trailer is used). The trailer speed must not, however, be greater than the maximum design speed of 40 km/h.).

WARNING

The bale transport trailer cannot be operated against its intended use, to transport the following in particular:

- *animals & people*
- *for transporting hazardous loads or loads which are not properly secured against shifting or falling out,*
- *any materials other than those specified in the User Manual*

Using it as intended also involves all actions connected with the safe and proper operation and maintenance of the machine. Due to the above, the user is obliged to:

- carefully read the OPERATOR'S MANUAL and WARRANTY BOOK and conform with the recommendations contained in these documents,
- understand the machine's operating principle and how to operate it safely and correctly,
- adhere to the established maintenance and adjustment plans,
- comply with general safety regulations while working,
- prevent accidents,
- comply with the road traffic regulations and transport regulations in force in the given country, in which the machine is used,
- carefully read the Operator's Manual and comply with its recommendations,
- only hitch the trailer to an agricultural tractor which fulfils all the requirements made by the trailer's Manufacturer.

The machine may only be used by persons, who:

- are familiar with the contents of this publication and with the contents of the agricultural tractor Operator's Manual,
- have been trained in trailer operation and work safety,

- have the required authorisation to drive carrying vehicles and are familiar with the road traffic regulations and transport regulations.

TABLE 1.4 *Wymagania ciągnika rolniczego*

CONTENTS		REQUIREMENTS
Brake system connection sockets		
Pneumatic system 1 conduit	-	according to A DIN 74 294
Pneumatic system 2 conduit	-	according to ISO 1728
Hydraulic system	-	according to ISO 7421-1
Nominal pressure of the system		
Single conduit pneumatic system	bar	5.8 – 6.5
Double conduit pneumatic system	bar	5.8
Hydraulic system	bar	150
Electrical system		
Electrical system voltage	V	12
Connection socket	-	7-pole socket compliant with ISO 1724
Tractor hitches		
Type of hitch	-	upper transport hitch
Requirements		
Min. tractor power	KM / kW	62,5 / 45,9

1.3 ACCESSORIES



TIP

Information concerning tyres is provided at the end of this manual in ANNEX A.

TABLE 1.5 *Equipment*

EQUIPMENT	STANDARD	ADDITIONAL	OPTIONS
OPERATOR'S MANUAL, WARRANTY BOOK	•		
drawbar eye Ø40 mm (in version with upper drawbar)	•		
Swivel drawbar eye Ø50 mm (in version with lower drawbar)			•
Double conduit pneumatic brake system	•		
Single conduit pneumatic brake system			•
2-line pneumatic brake system with ALB regulator			•
Hydraulic brake system			•
Toolbox		•	
Rear hitch		•	
Folding resistance ladders (for mounting with a linking chain) ⁽¹⁾	•		
Folding resistance ladders (for mounting with a linking cable) ⁽²⁾			•
Belt winders ⁽¹⁾		•	
Adjustable rear frame extending load area	•		
Spare wheel winch with spare wheel		•	
Mudguards (front and rear)		•	
Side under-run protection devices		•	
Linking chain ⁽¹⁾ ⁽³⁾		•	
Slow-moving vehicle warning sign		•	
Reflective warning triangle		•	

⁽¹⁾ – the equipment only for T024M trailer, ⁽²⁾ – the equipment only for T024 trailer,

1.4 WARRANTY TERMS & CONDITIONS

PRONAR Sp. z o.o., Narew guarantees the reliable operation of the machine when it is used according to its intended purpose as described in the *OPERATOR'S MANUAL*.

The repair period is specified in the *WARRANTY BOOK*.



TIP

Demand that the seller carefully and precisely fills out the Warranty Book and guarantee repair coupons. A missing date of purchase or sale point stamp, may make the user ineligible for any warranty repair or refund.

The guarantee does not apply to those parts and sub-assemblies of the machine, which are subject to wear in normal usage conditions, regardless of the warranty period. Consumables include the following parts/sub-assemblies:

- drawbar hitching eye,
- pneumatic system connector filters,
- tyres,
- brake shoes,
- bulbs and LED lamps,
- seals,
- bearings.

The warranty service only applies to such cases as: mechanical damage, which is not the user's fault, factory defects of parts, etc.

In the event of damage arising from:

- mechanical damage which is the user's fault, caused by road accidents,
- by inappropriate use, adjustment or maintenance, use of the trailer for purposes other than those for which it is intended,
- use of damaged machine,
- repairs carried out by unauthorised persons, improperly carried out repairs,

- making unauthorised alterations to machine design,

the user will lose the right to warranty service.

The user is obliged to report immediately on noticing any wear in the paint coating or traces of corrosion, and to have the faults rectified whether they are covered by the guarantee or not. Detailed guarantee regulations are contained in the *WARRANTY BOOK* attached to each machine.

Modification of the trailer without the written consent of the Manufacturer is forbidden. In particular, do NOT weld, drill holes in, cut or keep the main structural elements of the machine, which have a direct impact on the machine operation safety.

1.5 TRANSPORTATION

The machine is prepared for sale completely assembled and does not require packing. The only thing needs to be packed is the operation & maintenance manual and elements of additional equipment, if ordered.

Machine delivery to the customer is possible with the use of a vehicle. After coupling, it can be also transported with the use of a tractor.

1.5.1 TRANSPORT ON VEHICLE

Loading and unloading of the agricultural trailer from vehicle shall be conducted using loading ramp with the aid of agricultural tractor, overhead crane or hoisting crane. During work, adhere to the general principles of occupational health and safety (OHS) applicable to reloading work. Persons operating reloading equipment must have the qualifications required to operate these machines.

Lifting equipment used for transporting the machine must be attached only to the fixed structural elements of the machine. These elements are, first of all: frame, transport catches and axle.



IMPORTANT!

Do not attach or hitch the trailer by drawbar eye, under-run protection devices, mudguard brackets or other structural elements that are not sufficiently strong to withstand operations of this type.

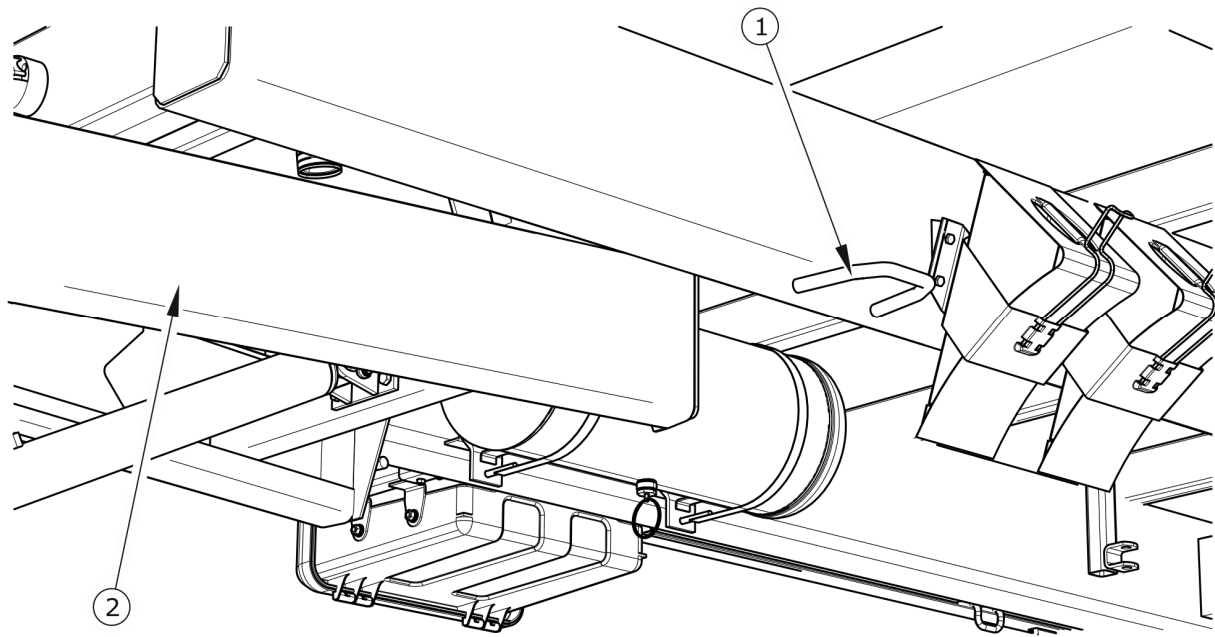

FIGURE 1.3 *Transport lugs*

(1) transport lug, (2) drawbar side member

The trailer should be attached firmly to the platform of the vehicle using straps or chains fitted with a tightening mechanism. In order to attach the machine in a proper manner, use transport lugs (1) – figure (1.3) and fasten axles, lower longitudinal members of the frame and possibly structural elements of the rotating frame.

Chocks, wooden blocks or other objects without sharp edges should be placed under the wheels of the trailer to prevent it from rolling. Wheel blocks must be nailed to the vehicle load platform planks or secured in another manner preventing their movement.

Use certified and technically reliable securing measures. Worn straps, cracked securing catches, bent or corroded hooks as well as elements damaged in a different way may be unsuitable for use. Carefully read the information stated in the Operator's Manual for the given securing measure. The number of securing elements (cables, straps, chains and stays etc.) and the force necessary for their tensioning depend on such factors as the machine weight, the carrying vehicle design, speed of travel and other conditions. For this reason it is impossible to define the securing plan precisely.

A correctly secured machine does not change its position with regard to the transporting vehicle. The securing elements must be selected according to the guidelines of the Manufacturer of these elements. In case of doubt apply a greater number of securing straps

in order to immobilise the machine. If necessary, sharp edges of trailer should be protected at the same time protecting the securing straps from breaking during transport.

**DANGER**

Incorrect use of securing measures may cause an accident.

**IMPORTANT!**

When being road transported on a motor vehicle the trailer must be mounted on the vehicle's platform in accordance with the transport safety requirements and the regulations.

Driver of the vehicle should be particularly careful during travel. Centre of gravity of the vehicle transporting the machine is shifted upwards, which poses a threat to stability of the vehicle and transported machine.

Use only certified and technically reliable securing measures. Carefully read the information contained in the Operator's Manuals for the given securing measures.

During reloading work, particular care should be taken not to damage parts of the machine's equipment or the paint coating. The tare weight of the agricultural trailer is given in table (3.1).

1.5.2 INDEPENDENT TRANSPORT BY THE USER

In the event of independent transport by the user, carefully read the Operators Manual and follow its recommendations. Independent transport involves towing the machine with own agricultural tractor to destination. During transport adjust travel speed to the prevailing road conditions, but do not exceed the maximum design speed.

**IMPORTANT!**

Before transporting independently, the tractor driver must carefully read this operator's manual and observe its recommendations.

1.6 ENVIRONMENTAL HAZARDS

A hydraulic oil leak constitutes a direct threat to the natural environment owing to its limited biodegradability. Because of the low solubility of oil in water, it is not highly toxic to living

organisms. An oil leak into water reservoirs may however lead to a reduction of the oxygen content. While carrying out maintenance and repair work which involves the risk of an oil leak, this work should take place on an oil resistant floor or surface. In the event of oil leaking into the environment, first of all contain the source of the leak, and then collect the leaked oil using available means. Remaining oil should be collected using sorbents, or by mixing the oil with sand, sawdust or other absorbent materials. The oil pollution, once gathered up, should be kept in a sealed, marked, hydrocarbon resistant container. The container should be kept away from heat sources, flammable materials and food.

**DANGER**

Used hydraulic oil or gathered remains mixed with absorbent material should be stored in a precisely marked container. Do not use food packaging for this purpose.

Oil which has been used up or is unsuitable for further use owing to a loss of its properties should be stored in its original packaging in the conditions described above. Waste oil should be taken to the appropriate facility dealing with the re-use of this type of waste. Waste code (L-HL 32 Lotos hydraulic oil): 13 01 10. Detailed information concerning hydraulic oil may be found on the product's Material Safety Data Sheet.

**TIP**

The hydraulic system of the trailer is filled with L-HL32 Lotos hydraulic oil.

**IMPORTANT!**

Waste oil should only be taken to the appropriate facility dealing with the re-use of this type of waste. Do NOT throw or pour oil into sewerage or water tanks.

1.7 DISPOSAL

In the event of decision by the user to withdraw the trailer from use, comply with the regulations in force in the given country concerning withdrawal from use and recycling of machines withdrawn from use. Before commencing dismantling, totally remove the oil from the hydraulic system and reduce air pressure completely in the pneumatic brake system (e.g. using air tank drain valve).



DANGER

During dismantling personal protection equipment shall be used i.e. protective clothing, boots, gloves and protective goggles etc.

Avoid contact of skin with oil. Do not allow used hydraulic oil to spill.

When spare parts are changed, worn out or damaged parts that cannot be reclaimed should be taken to a collection point for recyclable raw materials. Hydraulic oil should be taken to the appropriate facility dealing with the re-use of this type of waste.

SECTION

2

USER'S SAFETY

2.1 SAFETY ADVICE

2.1.1 BASIC SAFETY RULES

- Before proceeding with the operation of the trailer, the user should carefully get acquainted with these safety rules. When operating the trailer the user must observe all the safety instructions. Operation and maintenance of the trailer must be performed only by the persons qualified to operate agricultural tractors and machines.
- If the information included in the User Manual is not clear it is recommended for a user to contact the dealer authorized by the Manufacturer of the trailer providing technical services or directly with the Manufacturer.
- Improper or unintended use of the trailer as well as the improper maintenance and inobservance of all the instructions provided in this Charter pose a danger to a trailer user.
- As a residual risk exists the observing of safety rules and proper operation of the trailer should be the basic principle when using the machine.
- It is forbidden for persons unqualified for operating agricultural tractors to operate the bale trailer, children and persons under the influence of alcohol including.
- Non-observance of safety rules poses a threat to health of the machine operators and any outsiders.
- It is forbidden to operate the trailer against its intended use. A person operating the machine against its intended use bears the responsibility for and resultant consequences. Using the trailer for other purposes than those specified by the manufacturer (see Chapter (1.2)) is considered as unintended and may be the reason for the warranty terms & conditions to be revoked.
- Any modifications to the bale trailer introduced without the explicit consent of the PRONAR Narew releases the company from any liability concerning the modification-related defects or health impairment.
- Climbing up and down the trailer is admissible only when the machine is immobilized and with a tractor engine switched off. Safe and high enough ladders and platforms must be used when climbing and leaving the trailer.

- In case of the braking system failure it is forbidden to operate the trailer until the defect is repaired.
- Bale trailer disconnected from a tractor must be immobilized with parking brake. If a trailer is parked on a sloped or elevated area it must be additionally secured with the use of chocks or other elements without sharp edges placed against the wheels.
- It is forbidden to transport people or animals on the platform of the trailer.
- It is forbidden to connect the trailer to a tractor in case different hydraulic oil grades are used in both machines (applies to the trailer equipped with hydraulic braking system).
- It is forbidden to operate defective trailer.
- It is forbidden to exceed the allowable load capacity of the trailer. The exceeded load capacity may result in the trailer damage, loss of stability when pulled by a tractor, loss of transported products and causing danger when the trailer is operated or pulled.
- The technical condition of the trailer and tractor's coupling system and connection elements of braking and electrical system must be inspected each time before it is going to be used.
- Special care must be taken when connecting or disconnecting the trailer to a tractor.
- When connecting the trailer to a tractor no person can stay between the trailer and a tractor.
- When connecting the trailer to a tractor only the upper transport hook must be used. Inspect the safeguard mechanism.
- If the bale trailer is equipped with coupling system for connecting the second trailer, the extendable frame must be pulled in.
- Transported products must be placed evenly on the trailer.
- Keep safe distance when loading and unloading products from the trailer. The outsiders must stay away from the working area.

- Transported products must be protected from being displaced with the use of belts, chains, tapes or other fastening elements. The elements must be equipped with tensioning mechanism or have relevant safety attestations.
- Air tank or hydraulic braking system are under high pressure when the trailer is operated.
- Frequently control the condition of braking system. Any braking system oil spills or leakage must be eliminated.
- Control the connection and pneumatic and hydraulic cables technical conditions on a daily basis.
- When connecting hydraulic cables to a tractor, make sure that the tractor hydraulic braking system is not under pressure.
- Before any pneumatic or hydraulic braking system repair or maintenance works the air and oil pressure must be reduced.
- When injured by the compressed hydraulic oil, immediately consult with a doctor. Hydraulic oil can penetrate the skin and cause infection.
- Use only the hydraulic oil grade recommended by the Manufacturer. Never mix two different oil grades.
- The used hydraulic oil must be utilized.
- It is forbidden for a user to repair the control valve, braking actuator or braking force regulator. These elements must be either replaced or repaired by qualified workers.
- When replacing tires the trailer must be secured from rolling through the use of chocks or other blocking elements without sharp edges. Wheel removing may be performed only when the bale trailer is empty.
- Paint coat must be removed before proceeding with welding works. Vapors of burning paint are harmful for both people and animals. Welding works must be performed in a well-ventilated and illuminated room.
- Special attention must be paid to flammable or fusible elements when performing welding works (pneumatic and hydraulic braking system elements, elements made of

rubber or plastic). If there is a risk such elements may be damaged or burned they must be removed.

- Wheel or tire replacing works must be performed by trained and qualified persons. The works must be performed with the use of relevant tools.
- Inspect tightness of nuts before the first use of trailer, after the first travel under load and then every 6 months of use or after 25,000 km, whichever occurs first. In the event of intensive work, check the nut tightening at least every 10,000 km. The inspection should be repeated individually if a wheel has been removed from the wheel axle.
- Tire pressure must be regularly controlled.
- In case any failure is detected the trailer cannot be operated until the failure is repaired. It is forbidden to use the trailer when defected.
- Use protective gloves, tightly fitting clothes and proper tools when operating the trailer.
- Maintenance and repair works must be performed in accordance with the general work safety rules. When cut, the wound must be immediately rinsed and disinfected. In case of serious injuries consult with a doctor.
- Repair, maintenance and cleaning works must be performed with a tractor engine switched off and keys removed from the ignition switch.
- Screw connections must be regularly inspected.
- Before proceeding with welding or electrical installation works, the trailer must be disconnected from power supply.
- In the warranty period any repairs can be performed only by the service workers authorized by the Manufacturer.
- In case it is necessary to replace individual elements, only original ones can be used. This requirement inobservance may create danger to health or life of outsiders and machine operators or to contribute to the damage of the machine itself, thus constituting the basis for revoking the warranty terms & conditions.
- When performing works requiring lifting the trailer, proper hydraulic or mechanical and attested jacks must be used. After lifting, it is required to use stabile support as

additional protection. It is forbidden to perform any works under the trailer when it is lifted only with the use of a jack.

- It is forbidden to support the trailer with the use of fragile elements such as bricks, breezeblocks, concrete blocks).
- After lubricating, the excess amount of oil must be removed.
- Properly selected tools, tightly fitting clothes and protective gloves must be used when operating, maintaining or clearing the trailer.

2.1.2 RULES OF USING PUBLIC ROADS

- When using the trailer on public roads, it is necessary to place a “Slow Vehicle” plate on the rear side of the trailer.
- Observe traffic regulations.
- Exceeding the allowable load capacity of the trailer may result in its damage and pose a threat to the safety of other road users.
- Do not exceed the allowable traveling speed. Adjust the speed to road conditions.
- It is forbidden to leave the bale trailer without proper protection. The protection consists in applying the handbrake and, if required, placing chocks against the trailer wheels.
- The trailer must be equipped with warning or type approved triangle when using the trailer on public roads.
- While driving on public roads the trailer shall be marked with a warning triangle distinguishing slow-moving vehicles. The warning triangle should be attached to the rear ladder.

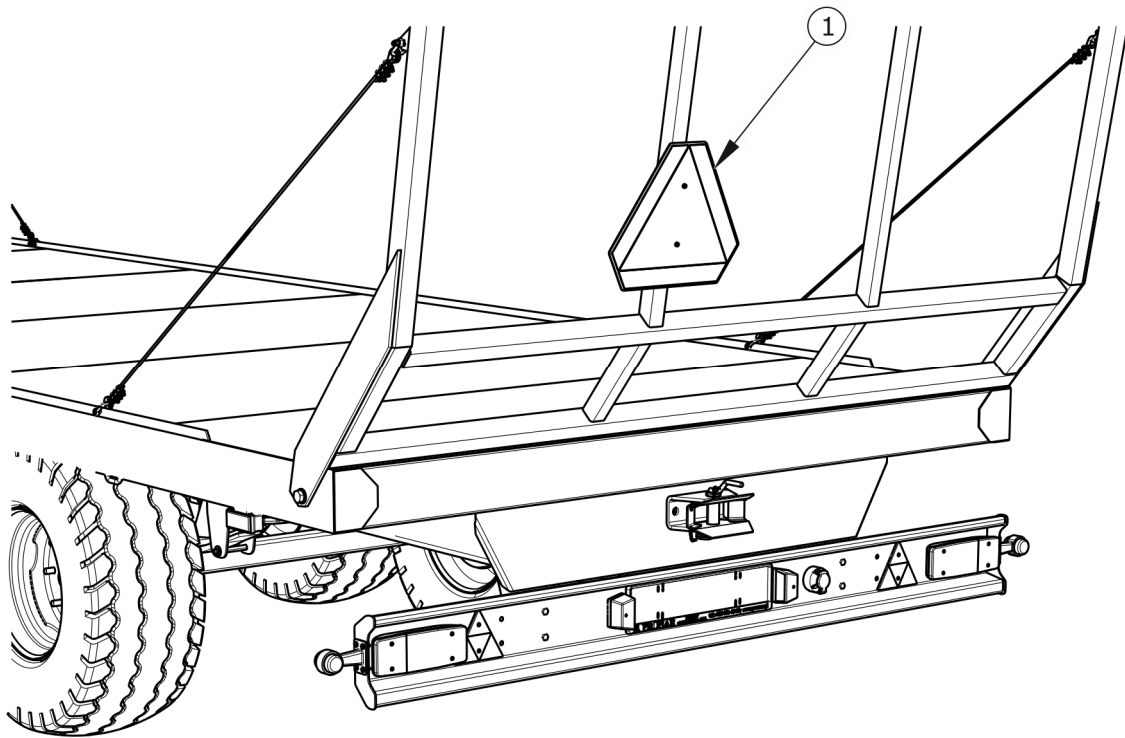

FIGURE 2.1 *Triangle placing*

(1) Low Speed Vehicle plate

2.1.3 RESIDUAL RISK DESCRIPTION

Every effort has been made by Pronar Sp. z o. o. in Narew to eliminate any accidents. However, there is still a residual risk which may result in an accident. The risk mainly concerns the following:

- using the trailer for purposes other than those specified by the Manufacturer,
- staying between a tractor and the trailer when a tractor engine is on and at the time the trailer is connecting to a tractor,
- operating the trailer by persons under the influence of alcohol or drugs,
- operating the trailer by unqualified persons,
- staying on the trailer platform when it is operated,
- careless performance of clearing, maintenance, repair works and technical inspection of the bale trailer.





Residual risk can be reduced to minimum when observing the following instructions:

- operate the trailer in an unrushed and careful manner,
- observe the information included in the User Manual,
- keep safe distance from dangerous and access-forbidden areas,
- do not stay on the trailer platform when it is operated,
- let qualified workers perform repair and maintenance works,
- use properly fitted protective clothes,
- protect the trailer from being accessed by unqualified persons, children in particular.

2.2 WARNING & INFORMATION LABELS

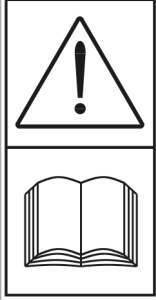
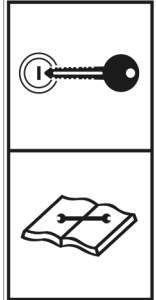
Bale trailer is marked with warning and information labels listed in the Table (2.1). The arrangement of the labels is shown on the Fig. (2.2). The user of the machine is obliged to make sure that the quality of the warning & information labels is legible throughout the whole period of the trailer operation. In case the quality deteriorates the labels must be replaced. User can purchase the labels from the Manufacturer or the dealer. Part numbers of information decals are given under pictogram description in table (2.1) and in Spare parts list. New assemblies replaced during repair works must be remarked with relevant safety labels. During agricultural trailer cleaning do not use solvents which may damage the coating of information label stickers and do not subject them to strong water jets.

TABLE 2.1 *Warning & information labels*

NO.	SYMBOL	INTERPRETATION
1		<p>Become familiar with <i>THE USER MANUAL</i></p> <p>70N-00000004</p>
2		<p>Switch off the engine and remove keys from the ignition switch before proceeding with maintenance or repair works.</p> <p>70N-00000005</p>
3		<p>Keep safe distance. Possible crushing by the shaft and protective ladder.</p> <p>147N-00000002</p>
4		<p>Regularly control the technical condition of screw connections of traction axis.</p> <p>104N-00000006</p>
5		<p>Lubrication to be performed according to instructions included in the User Manual</p> <p>104N-00000004</p>
6		<p>Bale trailer type</p> <p>74N-00000001</p>

* - air pressure in tire standard equipment, pressure value depends on tire type used.

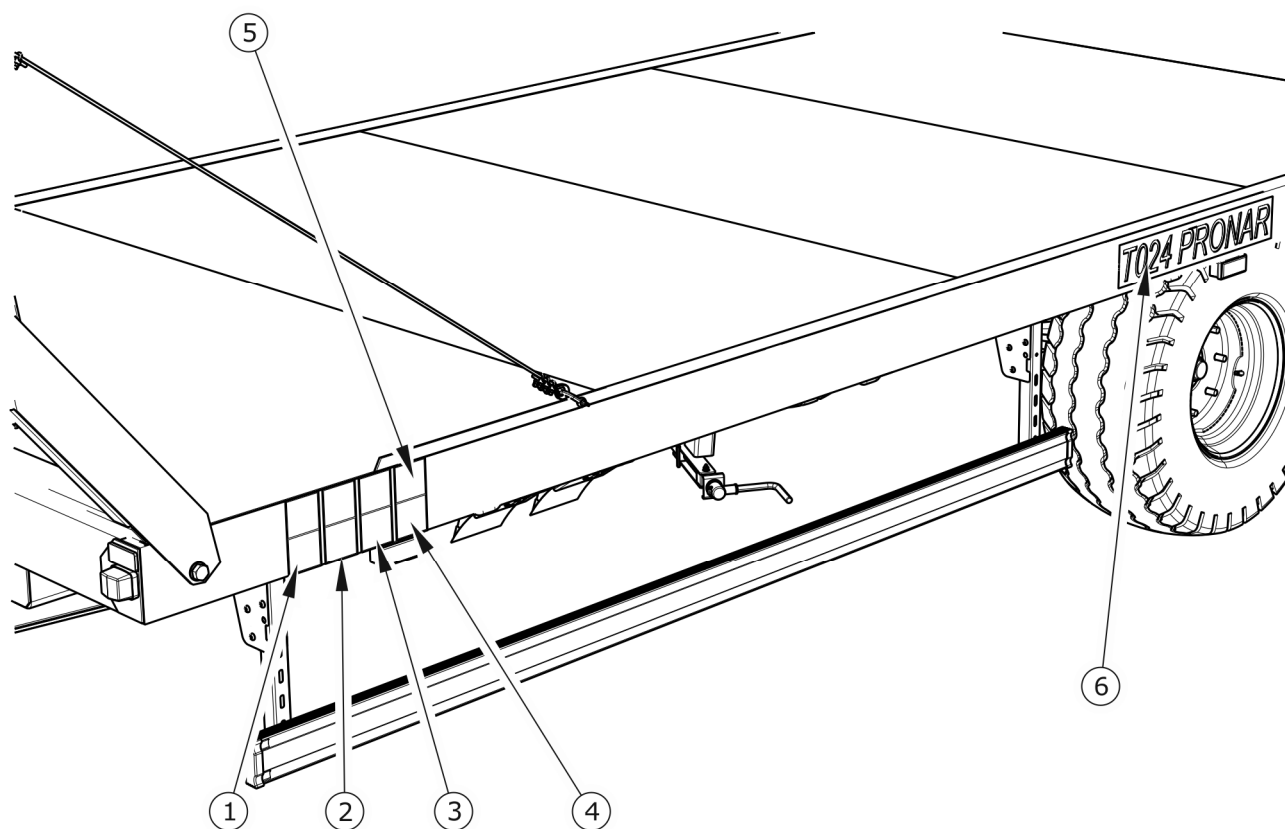

TABLE 2.2 *Markings in the Fig. comply with the Table 2.1 „Warning & Information Labels”*

SECTION

3

**DESIGN AND
OPERATION**

3.1 TECHNICAL SPECIFICATION

TABLE 3.1 *Basic technical data of standard fittings*

CONTENTS	UNIT	T024	T024M
Dimensions			
Length	mm	9,290	9,290
Width	mm	2,500	2,550
Height	mm	2,750	2,740
Load box dimensions			
Length of load surface	mm	7,170	7,170
Width	mm	2,435	2,517
Technical specification			
Carrying capacity	kg	8,900	8,700
Maximum gross weight	kg	12,000	12,000
Tare weight	kg	3,100	3,300
Height of platform from the ground	mm	1,110	1,060
Load surface	m ²	17.4	17.4
Other information			
Electrical system voltage	V	12	12
Wheel track	mm	1,750	1,820
Maximum design speed	km/h	40	40
Tractor power demand	hp/kW	62.5/45.9	62.5/45.9
Maximum vertical load of drawbar eye	kg	1,925	1,925

3.2 TRAILER DESIGN

3.2.1 CHASSIS

Frame (1) – of the load box is a structure welded from steel sections. The main support elements are longitudinal members connected with crossbars. Depending on the trailer version, the floor sides can be ended with a welded flat bar (T024) or a profiled side strip (T024M). The load platform, in its front part and rear part, is limited by ladders (2) and (3). Depending on the trailer version, the ladders can be folding or fixed. Deflection angle of folding ladders is limited by means of steel cables or a tensioning chain.

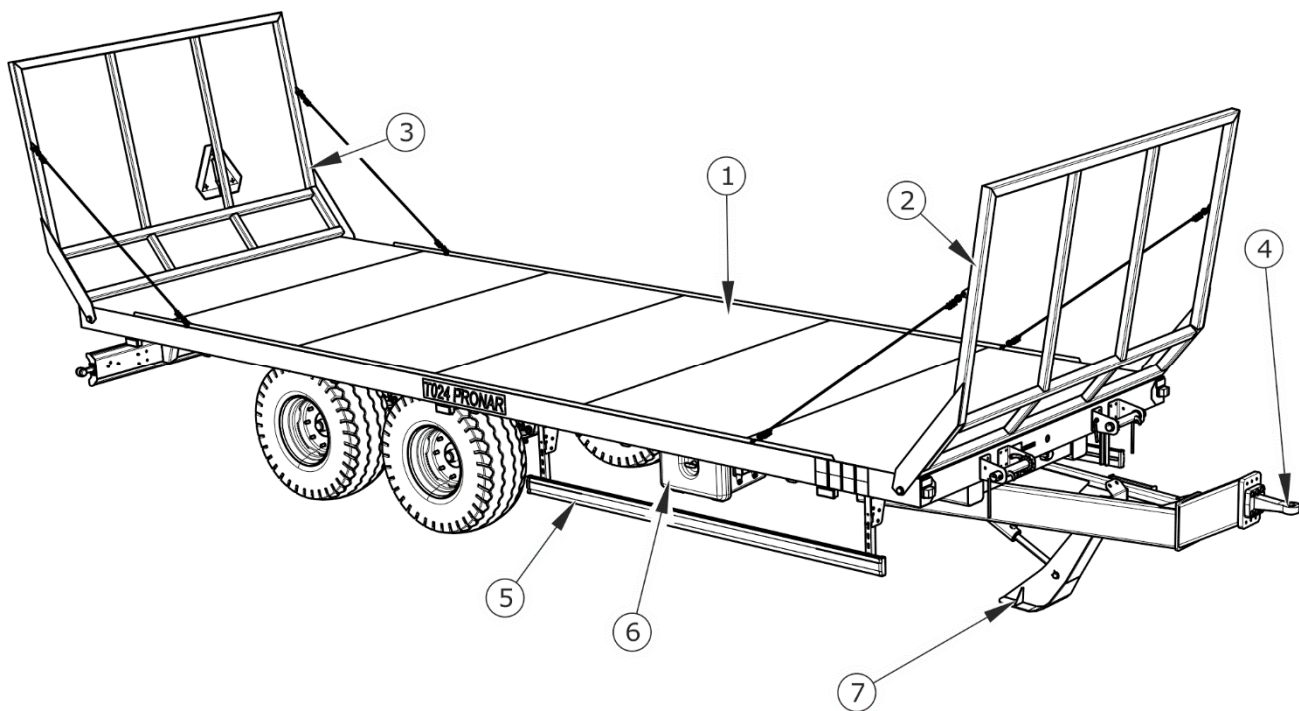

FIGURE 3.1 *Trailer construction*

(1) frame – load platform, (2) front ladder, (3) rear ladder, (4) drawbar eye, (5) under-run protection device, (6) toolbox

At the end of the trailer frame there is a lights support beam (5) which is designed for fixing electrical equipment, license plate and reflectors.

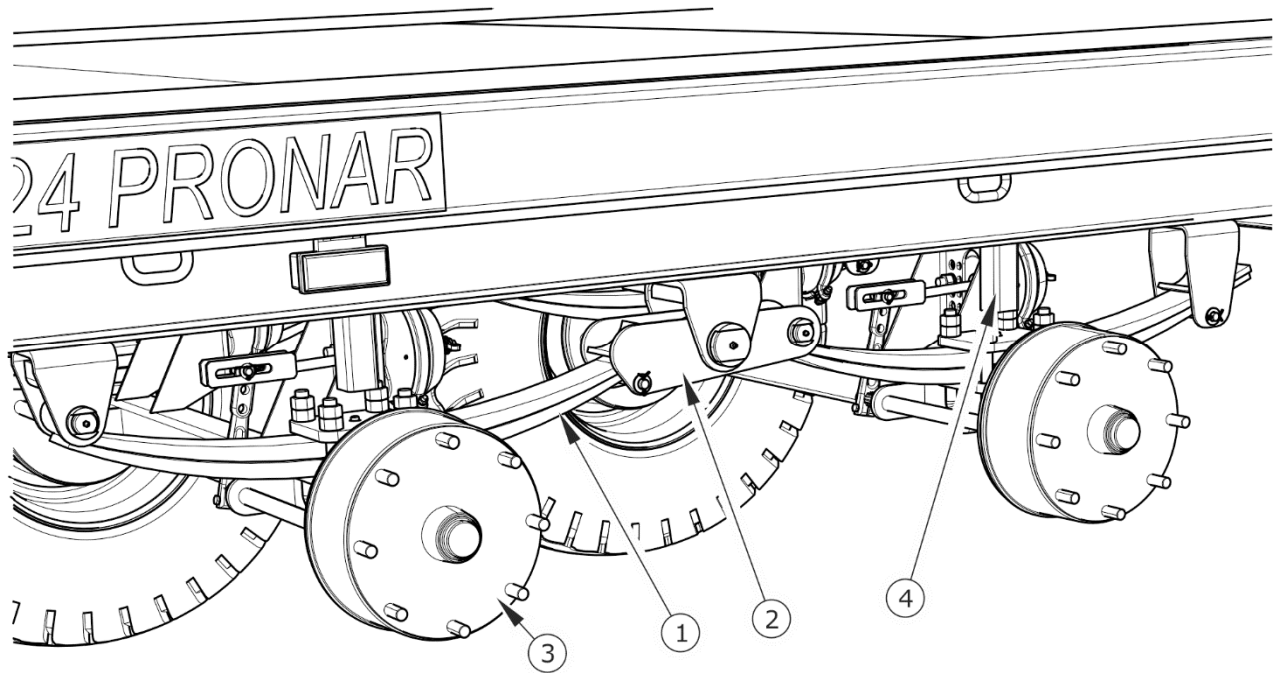

FIGURE 3.2 *Rear suspension*

(1) leaf spring, (2) rocker arm, (3) wheel axle, (4) rubber

Axes are made from square bars terminated with pins, on which wheel hubs are mounted on cone bearings. The wheels are single and equipped with shoe brakes activated by mechanical cam expanders.

3.2.2 SIDE UNDER-RUN PROTECTION DEVICES

Two side under-run protection devices are installed in the central part of the chassis frame, on the left side and the right side of the trailer. The complete under-run protection devices are bolted to holder C-section welded to the trailer frame.

The design of the side under-run protection devices enables their locking in the transport position and in the raised position.

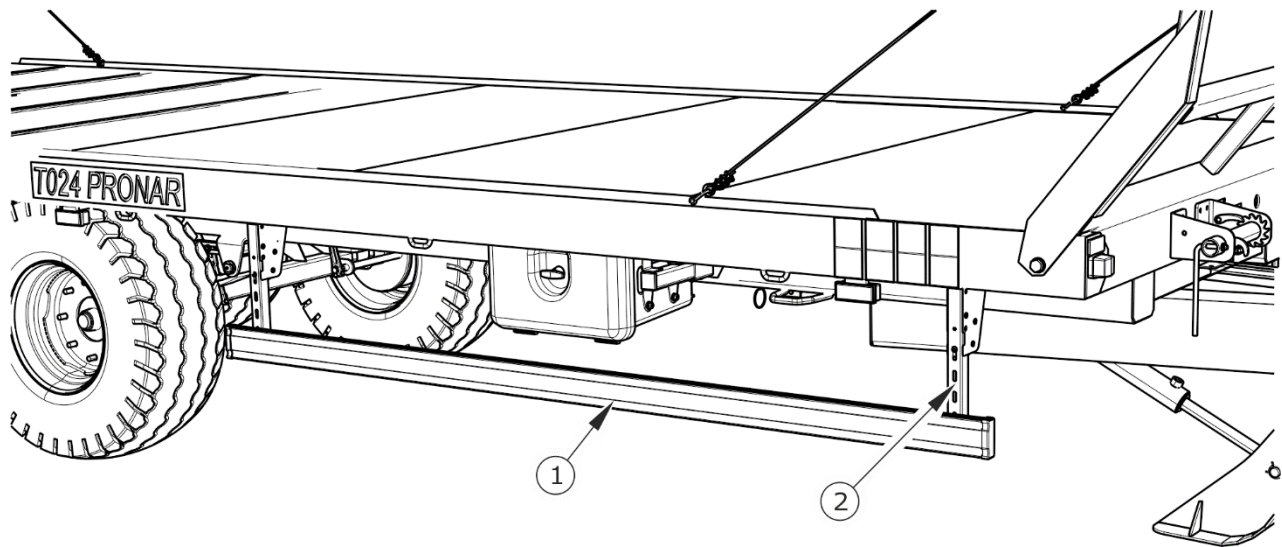

FIGURE 3.3 Side under-run protection devices

(1) strip of under-run protection device (2) bracket

ATTENTION



Side under-run protection devices must not be used as supporting elements while climbing on the trailer's platform.

Before driving off, make certain that side under-run protection devices are set in transport position.

3.2.3 MAIN BRAKE

Depending on the version, the trailer is equipped with one of the three types of main brake:

- double conduit pneumatic system with three position regulator, figure (3.4) – standard equipment,
- single conduit pneumatic system with three position regulator, figure (3.5) - optional equipment,
- hydraulic braking system – figure (3.6) - optional equipment,

The main brake (pneumatic or hydraulic brake) is activated from the tractor driver's cab by depressing the brake pedal. The task of the control valve is to activate the trailer's brakes when the brake pedal is depressed in the tractor. Furthermore, in case of an inadvertent

disconnection of the conduit between the trailer and the tractor, the control valve will automatically activate trailer's brakes - applies only to pneumatic systems.

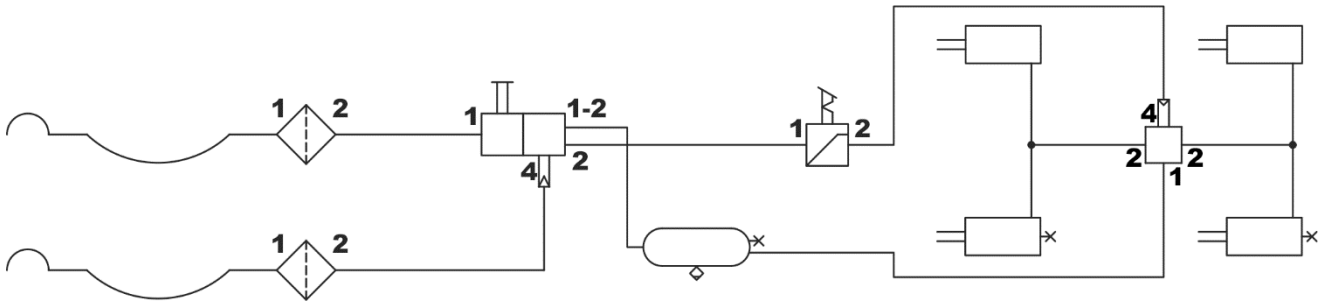

FIGURE 3.4 *Diagram of double conduit pneumatic system with manual regulator*

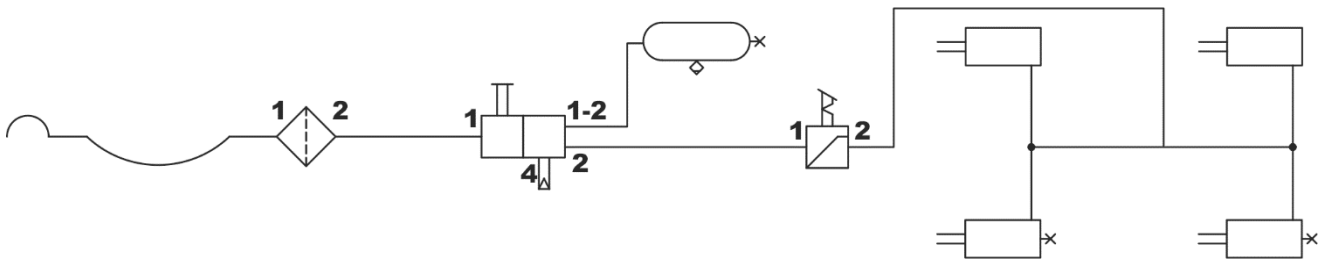



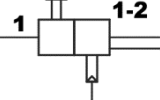
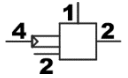
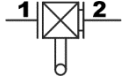
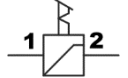

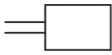



FIGURE 3.5 *Diagram of double conduit pneumatic system with automatic regulator*



FIGURE 3.6 *Hydraulic system diagram*

TABLE 3.2 *List of symbols used on the diagrams*

SYMBOL	MEANING
	Pneumatic connection (plug)
	Pneumatic connection with cut-off valve (socket)
	Air filter
	Drain valve
	Main control valve
	Relay valve
	Automatic regulator of braking force
	Three-position manual regulator of braking force
	Conduit connection (connector)
	Air tank
	Cylinder
	Valve - control connection

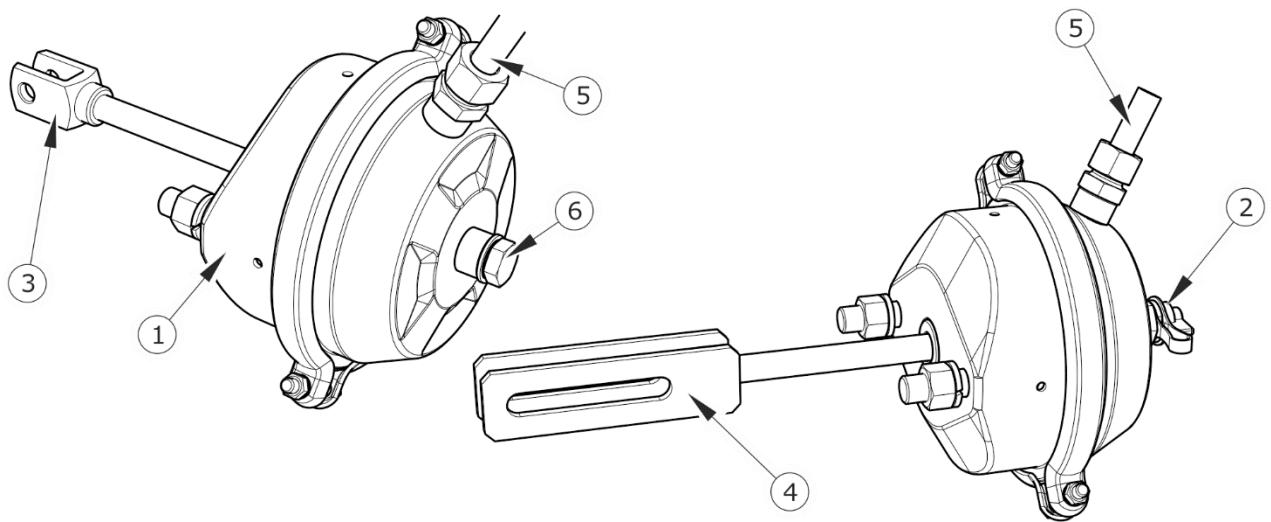

FIGURE 3.7 Brake pneumatic cylinders

(1) membrane cylinder, (2) control connection, (3) short fork, (4) long fork, (5) pneumatic conduit, (6) plug

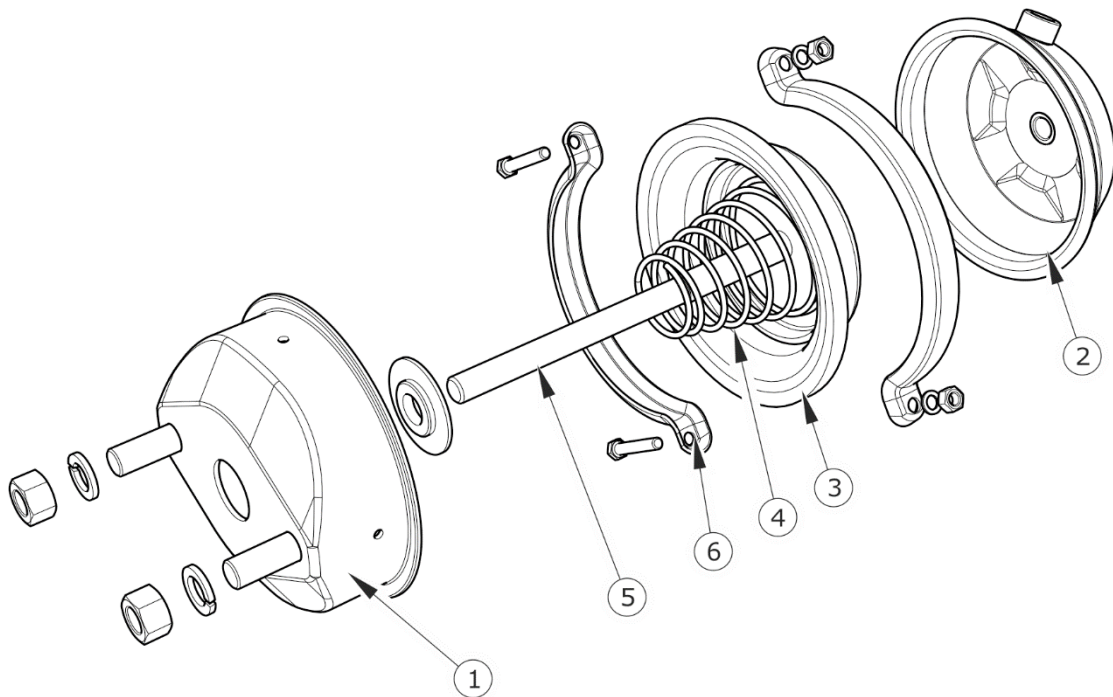

FIGURE 3.8 Design of pneumatic cylinder

(1) front cover, (2) rear cover, (3) membrane, (4) spring, (5) cylinder rod, (6) clamping ring

Valve used in the system is equipped with a circuit causing the brakes to be applied when trailer is disconnected from the tractor - figure (3.9). When compressed air conduit is

connected to the tractor, the device automatically applying the brakes changes its position to allow normal brake operation.

Three-step brake force regulator (2)- figure (3.9), adjusts braking force depending on setting. Switching to a suitable working mode is done manually by the machine operator using the lever (4) prior to moving off. Three working positions are available: A - "no load", B - "half load" and C - "full load".

In double conduit systems with automatic regulator, braking force is adjusted automatically depending on the trailer load. The automatic regulator does not require maintenance during normal use of the trailer.

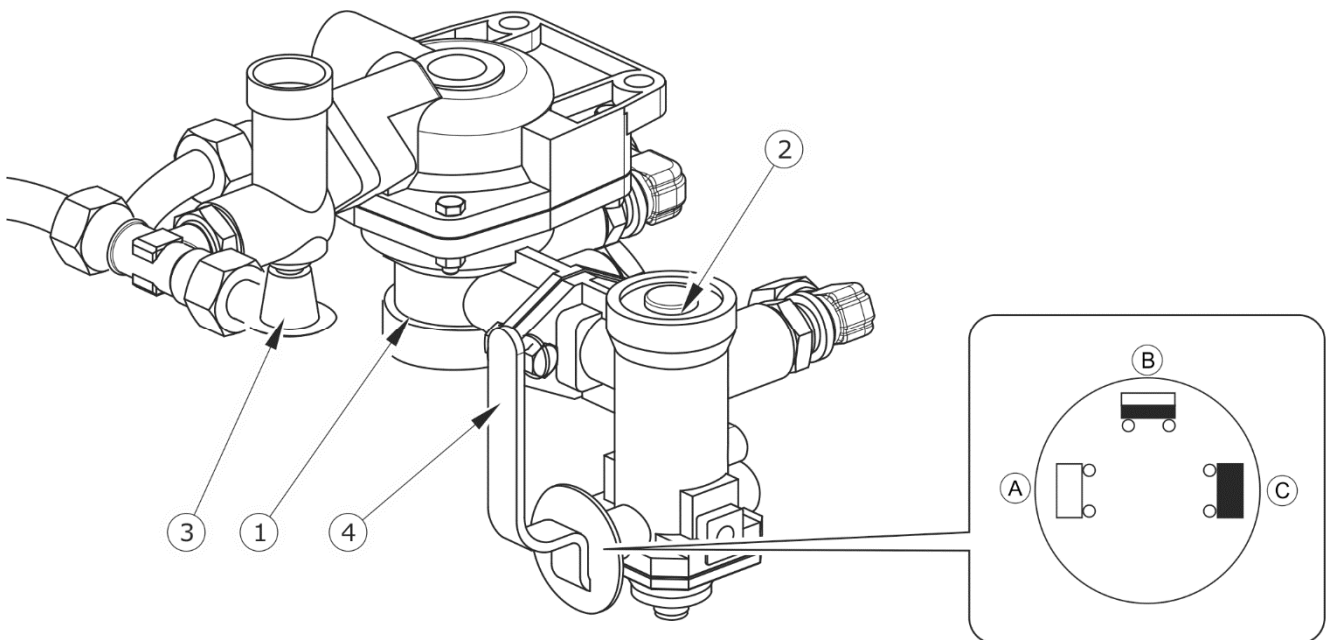

FIGURE 3.9 Control valve and braking force regulator

(1) control valve, (2) braking force regulator, (3) trailer parking brake release button, (4) work selection regulator lever, (A) position "NO LOAD", (B) position "HALF LOAD", (C) position "FULL LOAD"

3.2.4 PARKING BRAKE

The parking brake is used for immobilising the trailer while parking. The brake crank mechanism, located on the left side of the frame, is connected with the axle expander levers using a steel cable. Rotation of the crank increases tension of the steel cable. Expander arms exert pressure on brake shoes and cause the axle to brake. Prior to moving off, handbrake must be released - steel cable must hang loose.

3.2.5 ELECTRIC LIGHTING SYSTEM

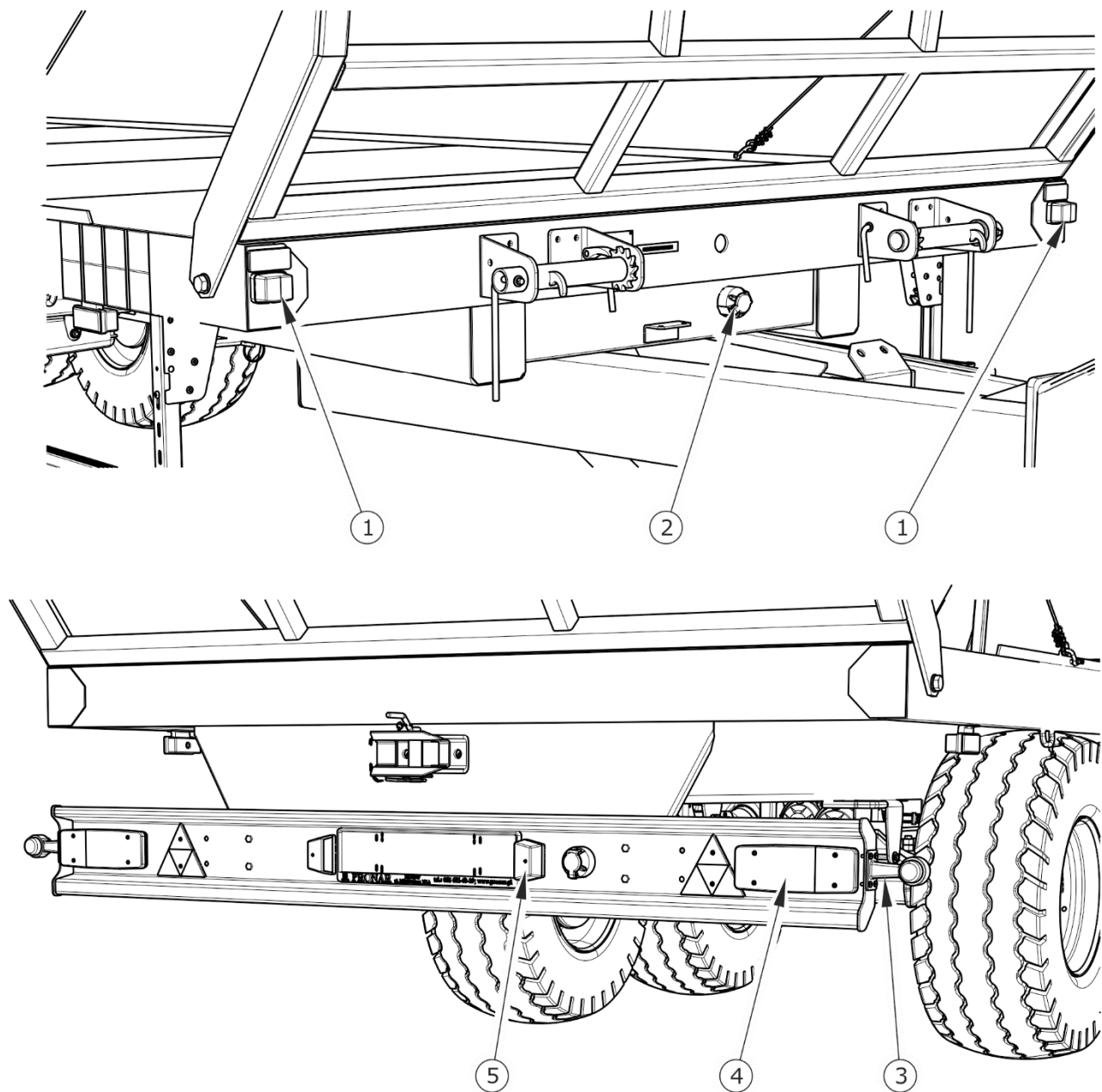

FIGURE 3.10 Arrangement of electrical system components

(1) front parking light, white, (2) 7-pin connection socket, (3) rear clearance light, (4) rear lamp assembly, (5) license plate light

The trailer's electrical system is designed for supplying from direct current source of 12 V. Connection of the trailer's electrical system with the tractor should be made through an appropriate connection lead delivered as standard equipment of the machine.

Arrangement of electrical system components and connection diagram of the connection socket are shown in figures (3.10) and (3.11)

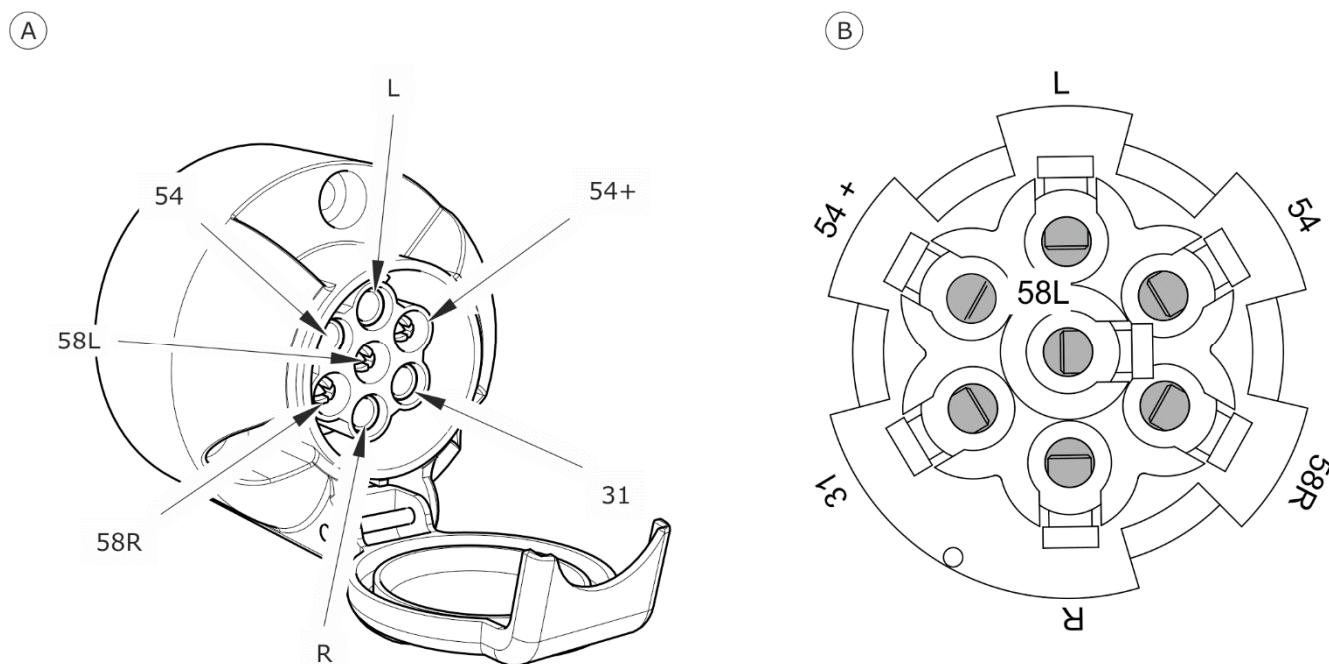

FIGURE 3.11 Connection socket

(A) view of socket, (B) view of socket on the wiring harness fixing side

TABLE 3.3 Marking of connection socket's connections

SIGN	FUNCTION
31	Ground
54+	Power supply +12V
L	Left indicator
54	STOP light
58L	Rear left parking light
58R	Rear right parking light
R	Right indicator

3.2.6 HYDRAULIC SYSTEM OF SHEAR TYPE DRAWBAR SUPPORT

Hydraulic system design is shown in Figure (3.12). Support foot (4) is extended and folded using hydraulic cylinder (1) controlled by means of the tractor's external hydraulic system. Cut-off valve (2) is used for closing oil flow to the cylinder when parking the trailer or travelling with the support folded to transport position. The valve positions (opened/closed) are marked with information decal (3). The valve positions (opened/closed) are marked with information decal (3).

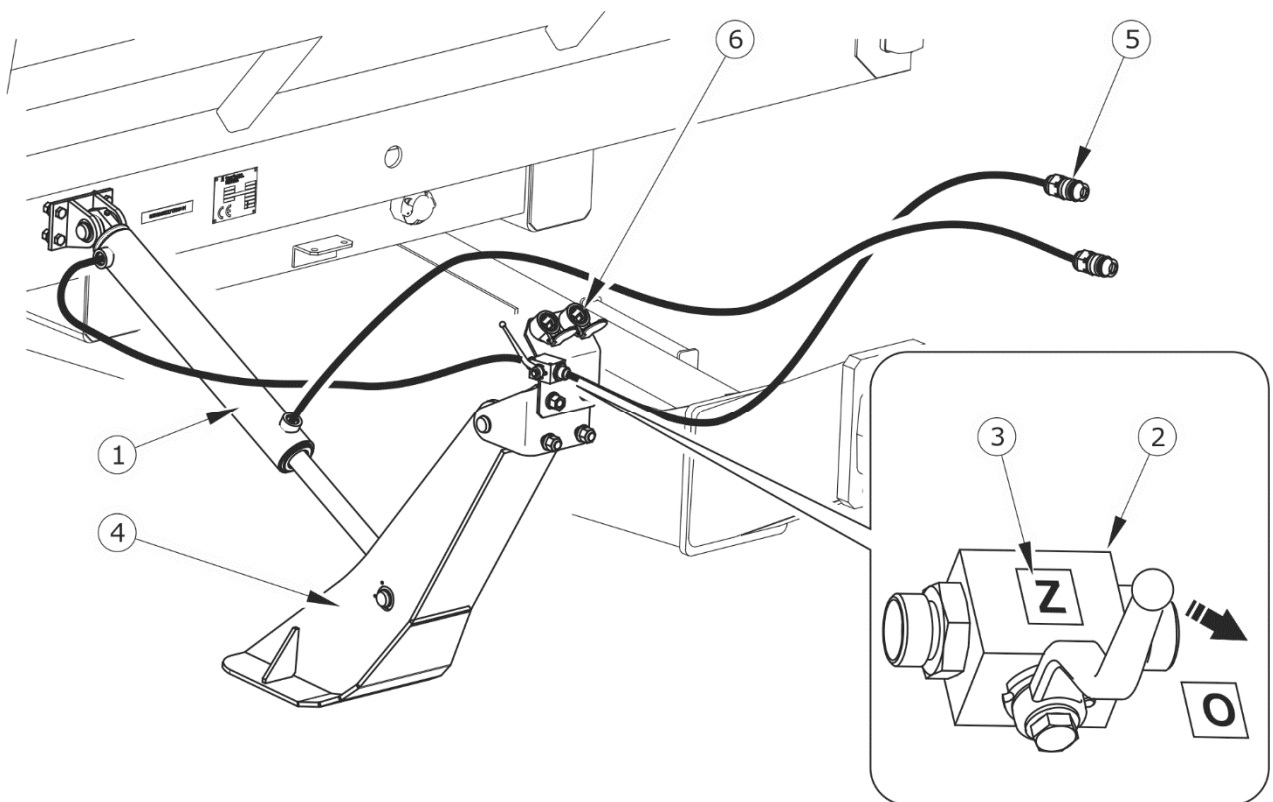

FIGURE 3.12 *Design of the support's hydraulic system*

(1) hydraulic cylinder, (2) cut-off valve, (3) information decal, (4) support foot, (5) hydraulic plug, (6) plug socket (holding socket)

SECTION

4

CORRECT USE

4.1 PREPARING THE TRAILER FOR WORK

4.1.1 PRELIMINARY INFORMATION

The trailer is supplied to the user completely assembled and does not require additional mounting operations of machine sub-assemblies. The manufacturer guarantees that the machine is fully operational and has been checked according to quality control procedures and is ready for use. This does not release the user from an obligation to check the machine's condition prior to purchasing and before first use.

4.1.2 HAND-OVER AND INSPECTION OF THE MACHINE AFTER DELIVERY

After delivery of the machine to the buyer, the user is obliged to check technical condition of the trailer (one-time inspection). While buying the machine, the user must be informed by the seller about the method of use of the machine, risks resulting from the use for purposes other than intended, the method of the machine hitching and the principles of the machine operation and design. Detailed information concerning the machine hand-over are included in the *WARRANTY BOOK*.

Checking the trailer after delivery

- Check completeness of the machine according to order.
- Check technical condition of safety guards.
- Check condition of paint coating; check the machine for traces of corrosion.
- Check the machine for damage resulting from wrong transport of the machine to its destination (crushing, piercing, bending or breaking of minor elements etc.).
- Check air pressure in tyres and check correct tightening of wheel nuts.
- Check technical condition of drawbar eye and if correctly installed.

If non-conformities are found, do not hitch and start using the trailer. Discovered defects should be notified directly to the seller in order to remove them.

ATTENTION

The seller is obliged to conduct the first start up of the trailer in the presence of the user.

The user trained by the seller is not released from the obligation to read this Operator's Manual carefully.

4.1.3 PREPARING THE TRAILER FOR THE FIRST USE, TEST RUN OF THE TRAILER

**TIP**

All maintenance activities concerning the trailer are described in detail in further sections of the Operator's Manual.

Preparing for the test run

- The user must read this *OPERATOR'S MANUAL* and observe all the recommendations contained in it.
- Adapt the height of the trailer drawbar to the tractor hitch.
- Visually inspect the trailer according to the guidelines presented in section *PREPARING THE TRAILER FOR USE*.
- Hitch machine to tractor. Immobilise the tractor with parking brake.

Test start

- Check all the trailer's lubrication points, lubricate the machine as needed according to recommendations provided in section 5,
- Check if the nuts and bolts fixing the wheels are properly tightened.
- Drain air tank of the braking system.
- Ensure that hydraulic, pneumatic and electric connections in agricultural tractor are according to the requirements. Otherwise, the trailer should not be hitched to the tractor.
- Hitch trailer to tractor.

- Switch on individual lights, check correct operation of electrical system.
- Release tractor's parking brake. Perform test drive. Check the trailer's braking efficiency during driving.
- Stop tractor and turn off the engine, immobilise the tractor and trailer with parking brake.

If during test run worrying symptoms occur such as:

- excessive noise and abnormal sounds originating from the rubbing of moving elements,
- leaky brake system, hydraulic oil leaks,
- incorrect operation of brake cylinders,
- other faults,

stop operating the trailer and do not operate it until the malfunction is corrected. If a fault cannot be rectified or the repair could void the warranty, please contact retailer for additional clarifications or to perform the repair.

4.1.4 PREPARING THE TRAILER FOR NORMAL USE

Scope of inspection activities

- Visually inspect if the tyres are properly inflated. In case of doubt, carefully check tyre pressure.
- Check technical condition of drawbar eye.
- Check correctness of electrical system operation.
- Check technical condition and completeness of safety guards.
- Install the slow-moving vehicle warning sign - if the trailer is used on public roads.

DANGER

Careless and incorrect use and operation of the trailer, and non-compliance with the recommendations given in this operator's manual is dangerous to your health.

The machine must never be used by persons, who are not authorised to drive agricultural tractors, including children and people under the influence of alcohol or other drugs.

Non-compliance with the safety rules of this Operator's Manual can be dangerous to the health and life of the operator and others.

Ensure that hydraulic, pneumatic and electric connections and the hitch of agricultural tractor are according to the Manufacturer's requirements, if not the trailer should not be hitched to the tractor. In order to hitch the trailer to the tractor, perform the actions below in the sequence presented.

Hitching to tractor

- ➔ Position agricultural tractor directly in front of the trailer's drawbar eye.
- ➔ Reverse the agricultural tractor near the trailer's drawbar eye.
- ➔ Connect the conduits of the support hydraulic system.
- ➔ Open the cut off valve of the support. Using the tractor's hydraulic system, set the trailer's drawbar hitching eye at such a height that it is possible to hitch the machine.
- ➔ Hitch the trailer to the tractor's hitch, check the hitch lock protecting the machine against accidental unhitching.
- ➔ If the agricultural tractor is equipped with an automatic coupler, ensure that the hitching operation is completed and that drawbar eye is secured.
- ➔ Raise parking stand to the upper extreme position. Close the cut-off valve.
- ➔ Turn off tractor engine. Ensure that unauthorised persons do not have access to the tractor cab.
- ➔ Connect the braking system conduits.
 - ⇒ If the trailer is equipped with a double conduit pneumatic system, first connect the yellow pneumatic conduit to the yellow socket in the

tractor and then connect the red conduit to the red socket in the tractor.

- ⇒ If the trailer is equipped with a single conduit pneumatic system, connect the black pneumatic conduit to the black socket in the tractor.
- ⇒ If the trailer is equipped with a hydraulic braking system, connect the braking system conduit to proper hydraulic socket in the tractor.

- ➔ Connect the electrical system lead.
- ➔ Check and, if necessary, protect conduits against rubbing or other mechanical damage.
- ➔ Just before driving off, remove chocks from under the trailer's wheels and release parking brake.

DANGER



When hitching, there must be nobody between the trailer and the tractor. When hitching the machine, tractor driver must exercise due caution and make sure that nobody is present in the hazard zone.

When connecting the hydraulic or pneumatic conduits to the tractor, make sure that the hydraulic and pneumatic systems of the tractor and the trailer are not under pressure.

Ensure sufficient visibility during hitching.

After completion of hitching check the security of the hitching pin.

When turning, connecting conduits must hang loosely and not become tangled with moving elements of machine and tractor.

Unhitching

In order to unhitch the trailer from the tractor follow these steps.

- ➔ Immobilise the tractor with parking brake.
- ➔ Open the cut off valve of the support's hydraulic system.
- ➔ Lower the support to such a position as to make it possible to unhitch the trailer's drawbar eye.
- ➔ Turn off tractor engine and close the tractor cab to prevent unauthorised access.
- ➔ Place chocks under the trailer's wheels in order to prevent the machine from rolling.
- ➔ Disconnect electric lead.

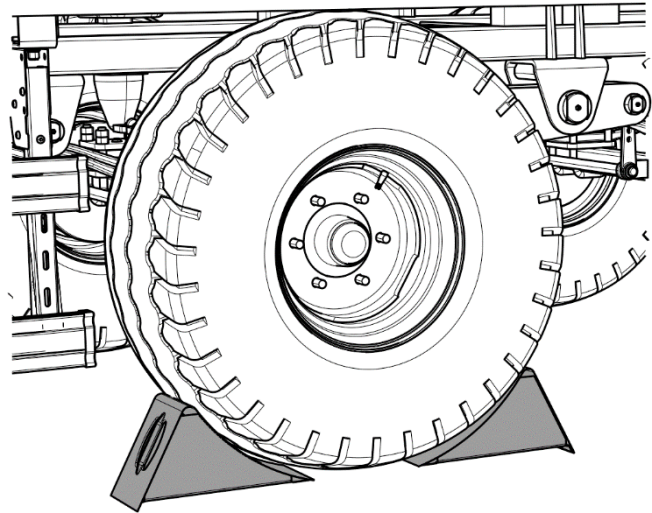

FIGURE 4.1 *Proper position of chocks*

DANGER



Exercise caution when unhitching the trailer from the tractor. Ensure good visibility. Unless it is necessary, do not go between tractor and machine.

Before disconnecting conduits and drawbar eye, close tractor cab and secure it against access by unauthorised persons. Turn off tractor engine.

The trailer must not be disconnected when loaded.

- ➔ Disconnect braking system conduits.
 - ⇒ If the trailer is equipped with a double conduit pneumatic system, first disconnect the red conduit and then disconnect the yellow conduit.
 - ⇒ If the trailer is equipped with a single conduit pneumatic system, disconnect the black conduit.
 - ⇒ Disconnect proper conduit of the hydraulic braking system from the tractor's socket.
- ➔ Protect conduit ends with covers.

- ➔ Release tractor hitch, drive tractor away from the slurry tanker.

**ATTENTION**

The trailer must not be used when not in working order.

4.2 LOADING AND SECURING LOAD

4.2.1 GENERAL INFORMATION ABOUT LOADING

The trailer is designed for transport of harvested crops and agricultural products in the form of pressed bales or blocks, at the farm and on public roads. The machine is also designed for transport of harvested crops and agricultural products transported on pallets.

The trailer must be positioned to travel forwards and be hitched to the tractor. Loading should only take place, when trailer is placed on flat level surface and hitched to tractor. Before loading, check the technical condition of linking cables or chains and correctness of their attaching to the ladders and trailer frame. Do not load or drive the trailer with damaged linking cables or chains. It is recommended to unload the trailer using a loader, conveyor or forklift truck. Keep a safe distance during loading and unloading. Do not allow anyone to approach the place where works are carried out.

Load should be uniformly distributed along the length and width of the platform in order to ensure proper distribution of axle loads and proper stability of the trailer. Load must not extend beyond the outline of the load platform. Number of load layers depends on size of pressed bales or blocks, their arrangement on the load platform and their weight. However, the permissible loading height defined by the road traffic regulations and permissible design load of the trailer must not be exceeded. When loading goods on pallets pay special attention to load distribution on the platform. Pallets must be secured against the displacement on the platform. Pallets must not be stacked in layers.

ATTENTION

Do NOT exceed the trailer's maximum carrying capacity.

Load placed on the platform must be uniformly distributed and properly secured.

While driving on public roads the extendible frame must be retracted.

The load must be arranged in such a way that it does not threaten the stability of the trailer and does not hinder driving.

Loading should be carried out by a person having appropriate authorisation for operating the equipment (if required).

DANGER

Overloading the trailer, erroneous loading and securing of the load is the most frequent cause of accidents during transport.

Uneven arrangement of the load may cause overloading of the trailer's axle.

People or animals must not be carried on the trailer.

During work, keep a safe distance from overhead electric power lines.

When loading or unloading the trailer, bystanders must exercise caution and keep a safe distance from danger zones.

4.2.2 SECURING LOAD

Load (rectangular or round bales, pallets or pallet boxes) should be adequately protected against moving by means of belts with a tightening mechanism. The belts may be attached to the following structural elements:

- left and right longitudinal member of the platform,
- front beam,
- rear beam of the extendible frame,
- transport lugs welded to the longitudinal members,
- oblong structural holes in the side part of profiled floor,

- tensioners bolted to front beam,
- grips welded to front ladder and rear ladder.

The extent of protection depends on loading method, type of load and size of load. If load is to be transported on slopes and/or in strong gusty winds conditions, limit the load height according to existing conditions.

Regardless of the type of load carried, the user is obliged to secure it in such a manner that the load is unable to spread and cause contamination of the road.

It is impossible to describe all methods of loading due to the diversity of materials, tools, means of fixing and securing a load. While working be guided by caution and own experience. The trailer user must carefully read the regulations concerning road transport and comply with them.

4.2.3 TENSIONER OPERATION

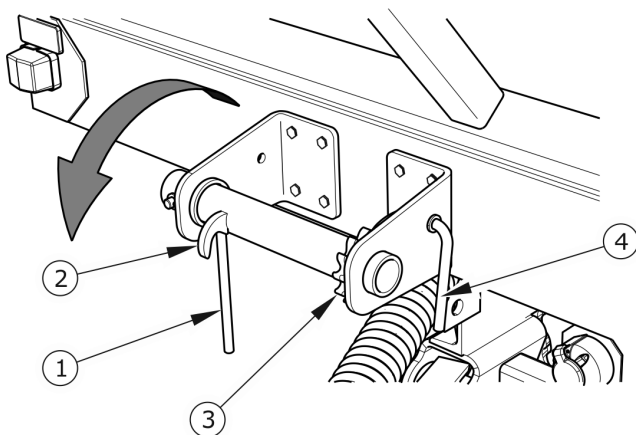

FIGURE 4.2 *Right tensioner*

(1) tensioner lever, (2) fixing hook, (3) pawl, (4) release lever

Scope of activities

Load can be attached using two tensioners bolted to the frame front beam (the tensioner is available only in T023M trailer as optional equipment).

Attach fixing belts or ropes to a fixed element of the trailer structure on one side, e.g. to fixing grips on the rear ladder and to a fixing hook in the tensioner on the other side. Rotate the lever in the direction indicated by arrow in order to tighten the belt.

In order to dismount belts or ropes, turn lever (1) until lever (4) can be released. Release lever (4) and remove belts.

4.3 LOAD TRANSPORT

When driving on public roads, respect the road traffic regulations, exercise caution and prudence. Listed below are the key guidelines for driving the tractor and trailer combination.

- Before moving off, make sure that there are no bystanders, especially children, near the trailer or the tractor. Ensure that the driver has sufficient visibility.
- Make sure that the trailer is correctly attached to the tractor and tractor's hitch is properly secured.
- The trailer must not be overloaded, loads must be uniformly distributed so that the maximum permissible axle loads are not exceeded. The trailer's maximum carrying capacity must not be exceeded as this can damage the trailer and pose a risk to the operator or other road users.
- Permissible design speed and maximum speed allowed by road traffic law must not be exceeded. The towing speed should be adapted to the current road conditions, load carried by the trailer, road surface conditions and other relevant conditions.
- When not connected to the tractor, the trailer must be immobilised using parking brake and with chocks placed under the wheels. Do NOT leave unsecured trailer. In the event of machine malfunction, pull over on the hard shoulder avoiding any risk to other road users and position reflective warning triangle according to traffic regulations.
- When driving on public roads, the trailer must be marked with a slow-moving vehicle warning sign attached to the rear wall of load box, if the trailer is the last vehicle in the group.
- While driving on public roads the trailer must be fitted with a certified or authorised reflective warning triangle.
- When driving, comply with all road traffic regulations, indicate an intention to turn using indicator lamps, keep all road lights and indicator lights clean at all times and ensure they are in good condition. Any damaged or lost lamps or indicator lights must be immediately repaired or replaced.
- Avoid ruts, depressions, ditches or driving on roadside slopes. Driving across such obstacles could cause the trailer or the tractor to suddenly tilt. This is of special importance because loaded trailer's centre of gravity is higher (especially a high volume load), which reduces safety. Driving near ditches or channels is

dangerous as there is a risk of the wheels sliding down the slope or the slope collapsing.

- Speed must be sufficiently reduced before making a turn or driving on an uneven road or a slope.
- When driving, avoid sharp turns especially on slopes.



ATTENTION

Travelling with a high-volume load over ruts, ditches, roadside slopes etc. constitutes a great risk of overturning the trailer. Exercise particular caution.

- Please note that the braking distance of the tractor and trailer combination is substantially increased at higher speeds and loads.
- Monitor trailer's behaviour when travelling on an uneven terrain, and adjust driving speed to road conditions, slow down early enough when turning.
- Prolonged driving across steep ground may lead to loss of braking efficiency.
- When driving with the trailer without load, the front ladder and the rear ladder should be folded.

4.4 UNLOADING

The trailer must be positioned to travel forwards and be hitched to the tractor. Unloading should only take place when the trailer is placed on flat level surface and hitched to tractor.



DANGER

*Ensure that during unloading nobody is in the vicinity of the load handled.
During work, keep a safe distance from overhead electric power lines.*

It is recommended to unload the trailer using a loader, conveyor or forklift truck. During work, ensure good visibility and exercise due caution. Immobilise tractor and trailer with parking brake and switch off tractor engine. Place wheel chocks under trailer wheel. Just before unloading, remove all securing elements (belts, ropes, etc.).

Unloading the trailer should be carried out in accordance with the general principles of workplace health and safety.

4.5 PROPER USE AND MAINTENANCE OF TYRES

When working with tyres, the trailer should be secured against rolling by placing chocks under the wheels. Wheels can be taken off the trailer axle only when the trailer is not loaded.

- Repair work on the wheels or tyres should be carried out by persons trained and entitled to do so. This work should be carried out using appropriate tools.
- Inspect tightness of nuts before the first use of trailer, after the first travel under load and then every 6 months of use or after 25,000 km, whichever occurs first. In the event of intensive work, check the nut tightening at least every 10,000 km. The inspection should be repeated individually if a wheel has been removed from the wheel axle.
- Regularly check and maintain correct air pressure in tyres according to Operator's Manual (especially if trailer is not used for a longer period).
- Air pressure in tyres should be also checked during the whole day of intensive work. Please note that higher temperatures could raise tyre pressure by as much as 1 bar. At high temperatures and pressure, reduce load or speed.
- Do not release air from warm tyres to adjust the pressure or the tyres will be underinflated when temperatures return to normal.
- Tyre valves should be protected with the appropriate caps to avoid soiling.
- Do not exceed the trailer's maximum design speed.
- When the trailer is operated all day, stop working for a minimum of one hour in the afternoon.
- Take a 30 minute-break for cooling tyres after driving 75 km or after 150 minutes of continuous travel, depending on which occurs first.
- Avoid potholes, sudden manoeuvres or high speeds when turning.

SECTION

5

MAINTENANCE

5.1 PRELIMINARY INFORMATION

When using the trailer, regular inspections of its technical condition and the performance of maintenance procedures are essential, which keep the machine in good technical condition. In connection with this the user of the trailer is obliged to perform all the maintenance and adjustment procedures defined by the Manufacturer.



ATTENTION

Repairs during the warranty period may only be performed by authorised service points.

Detailed procedures and extent of activities which the user may perform by himself are described in this section. In the event of unauthorised repairs, changes to factory settings and other actions, which are not regarded as possible for the trailer operator to perform, the user shall invalidate the warranty.

5.2 SERVICING WHEEL AXLE

5.2.1 PRELIMINARY INFORMATION

Work connected with the repair, change or regeneration of axle components should be entrusted to specialist establishments, having the appropriate technology and qualifications for this type of work.

The responsibilities of the user are limited to:

- inspection and adjustment of slackness of axle bearings,
- mounting and dismounting wheel, inspection of wheel tightening,
- checking and maintaining proper air pressure in tyres, evaluating technical condition of wheels and tyres,
- checking thickness of brake shoe linings,
- mechanical brakes adjustment,

Procedures connected with:

- changing grease in axle bearings,
- changing bearings, hub seals,
- replacement of brake shoes,
- other axle repairs,

may be performed by specialized vehicle service stations.

5.2.2 CHECKING WHEEL AXLE BEARINGS FOR SLACKNESS

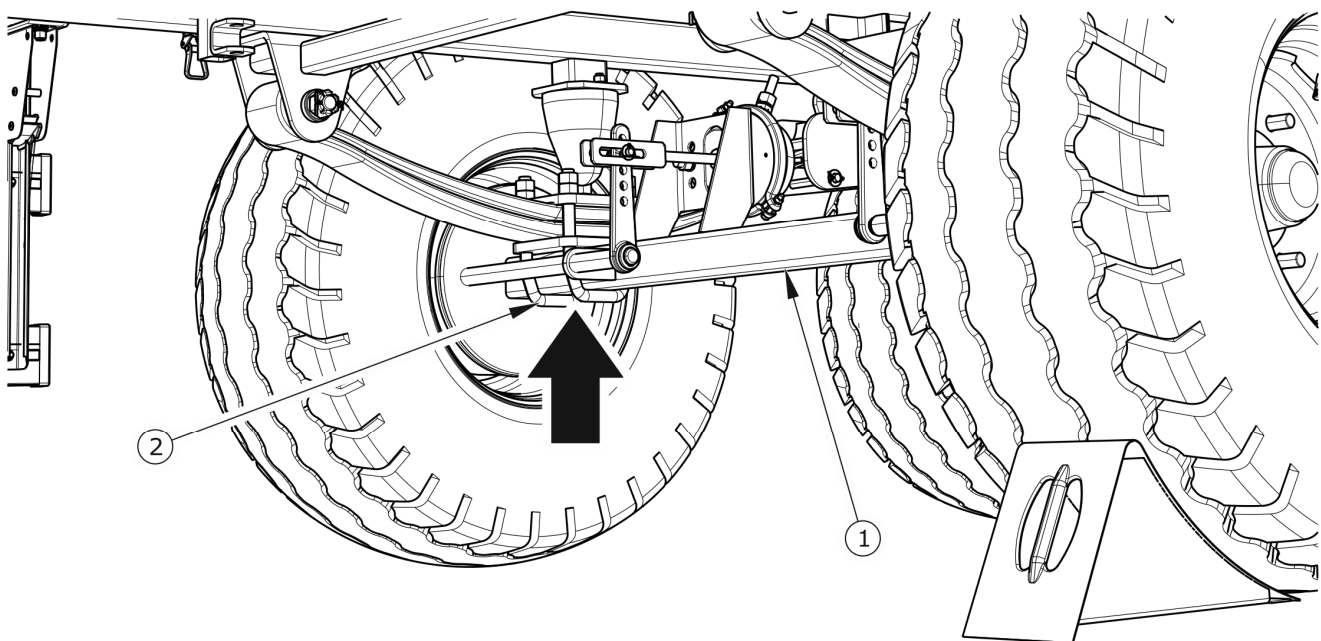

FIGURE 5.1 *Lifting jack support point*

(1) wheel axle, (2) U bolt

Preparation procedures

- ➔ Hitch trailer to tractor, braking tractor with parking brake.
- ➔ Park the trailer on hard level ground.
 - ⇒ Tractor must be placed to drive forward.
- ➔ Place chocks under the trailer's wheel that will not be raised. Ensure that machine will not move during inspection.
- ➔ Raise the wheel (opposite to the side where chocks are placed).

- ⇒ Lifting jack should be positioned in the place indicated by the arrow in figure (5.1). Lifting jack must be suitable for the weight of the machine.

Checking wheel axle bearings for slackness

- ➔ Turning the wheel slowly in both directions check that movement is smooth and that the wheel rotates without excessive resistance.
- ➔ Turn the wheel so that it rotates very quickly, check that the bearing does not make any unusual sounds.
- ➔ Holding the wheel above and below, try to feel any slackness.
 - ⇒ You may use a lever placed under the wheel supporting the other end of the lever on the floor.
- ➔ Lower the lifting jack, relocate the chocks to the other wheel and repeat the inspection procedure for the other wheels.

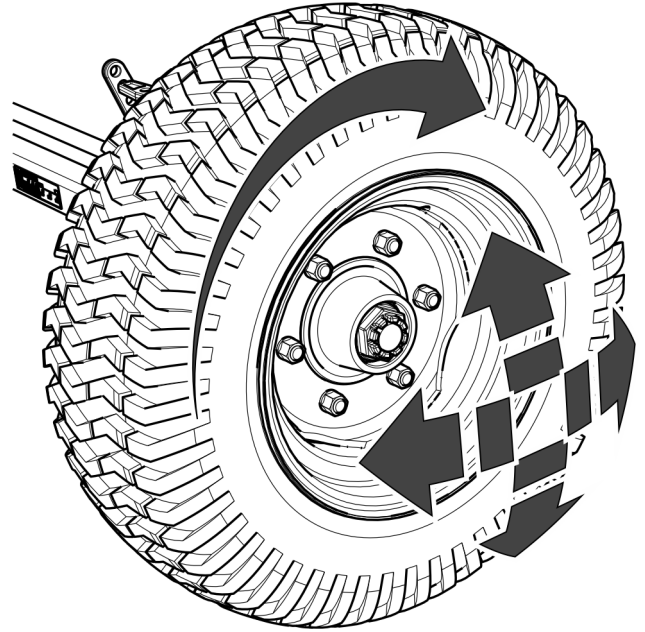

FIGURE 5.2 *Checking bearings for slackness*



TIP

If hub cover is damaged or missing, contamination and dampness enter the hub, which causes significantly faster wear of bearings and hub seals.

Life of bearings is dependent on working conditions of the trailer, loading, speed of travel and lubrication conditions.

If slackness is felt, adjust bearings. Unusual sounds coming from bearing may be symptoms of excessive wear, dirt or damage. In such a case, the bearing and sealing ring should be replaced with new parts (if they are not suitable for further operation) or cleaned and greased again.

**INSPECTION**

- *after travelling the first 1,000 km.*
- *Every six months of use or every 25,000 km.*

Check condition of hub cover, if necessary replace with a new cover. Inspection of bearing slackness may only be conducted when the trailer is hitched to tractor. The machine may not be loaded.

**DANGER**

Before commencing work the user must read the user's manual for the lifting jack and adhere to the manufacturer's instructions.

The lifting jack must be stably supported on the ground and so must the axle.

Ensure that trailer shall not move during inspection of axle bearing slackness.

5.2.3 ADJUSTMENT OF PLAY OF WHEEL AXLE BEARINGS

The wheel should turn smoothly without jamming and detectable resistance. Adjustment of bearing slackness may only be conducted when the trailer is not loaded and is hitched to the tractor.

Ensure that the trailer is properly secured and will not move during wheel dismounting.

- ➔ Take off hub cover (1) – figure (5.3).
- ➔ Take out cotter pin (3) securing castellated nut (2).

- ➔ Tighten castellated nut in order to eliminate looseness.
- ➔ Wheel should rotate with insignificant resistance.
- ➔ Undo nut (not less than 1/3 rotation) to align the nearest thread groove with the opening in wheel axle pin. Wheel should rotate without excessive resistance.
- ➔ The nut must not be excessively tightened. Do not apply excessive pressure because working conditions of the bearings may deteriorate.
- ➔ Secure castellated nut with cotter pin and mount the hub cap.
- ➔ Delicately tap the hub cap with rubber or wooden mallet.

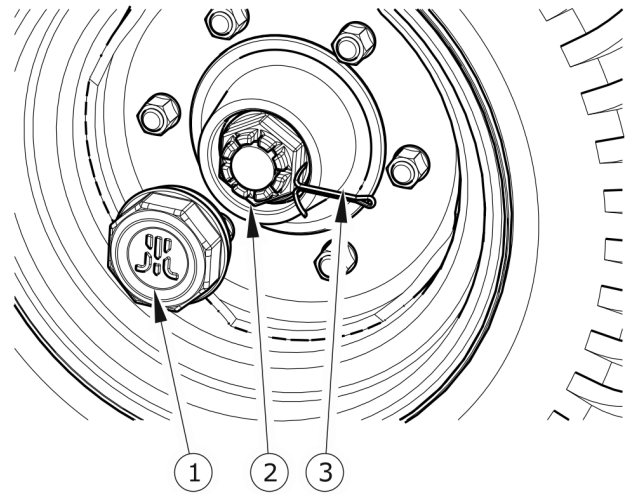

FIGURE 5.3 Adjustment of slackness

(1) hub cover, (2) castellated nut, (3) cotter pin

5.2.4 MOUNTING AND DISMOUNTING WHEEL, INSPECTION OF WHEEL NUT TIGHTENING

Wheel dismounting

- ➔ Place chocks under the wheel that will not be dismounted.
- ➔ Ensure that trailer shall not move during wheel dismounting.
- ➔ Loosen wheel nuts according to the sequence shown in figure (5.4).
- ➔ Place lifting jack and lift trailer.
- ➔ Dismount wheel.

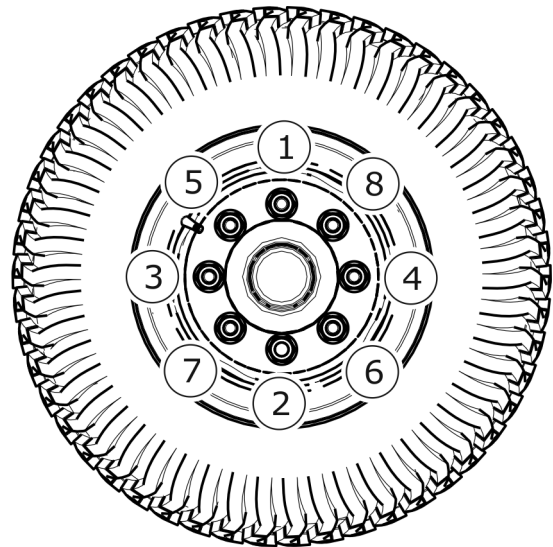
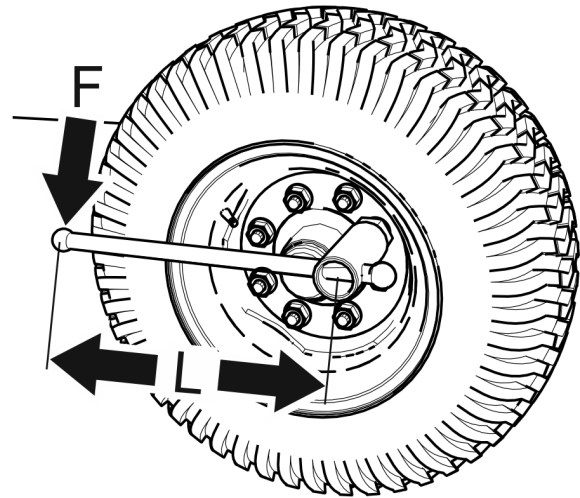

FIGURE 5.4 Sequence of undoing and tightening nuts

Wheel installation

- ➔ Clean axle pins and nuts of contamination.
- ⇒ Do not grease thread of nuts and pins.
- ➔ Check condition of pins and nuts, if necessary replace.
- ➔ Place wheel on hub, tighten nuts so that wheel rim tightly fits the hub.
- ➔ Lower the trailer, tighten nuts according to recommended torque and given sequence.



M18x1.5 - 270 Nm

FIGURE 5.5 Tightening method

(F) – weight of the person tightening the nut,
 (L) - length of spanner arm

Tightening nuts

Nuts should be tightened gradually diagonally, (in several stages, until obtaining the required tightening torque) using a torque spanner. If a torque spanner is not available, one may use an ordinary spanner. The arm of the spanner (L) figure (5.5) should be selected according to the weight of the person (F) tightening the nut. Remember that this method of tightening is not as accurate as the use of a torque spanner. Tightening of nuts should be checked with the frequency given in the below table. The activities should be repeated after each removal of a wheel from the wheel axle.

INSPECTION



- After the first use of the trailer.
- After first travel with load.
- Every 6 months of use or every 25 000 km, whichever occurs first.
- In the event of intensive work, check the nut tightening at least every 10,000 km.

TIP



Wheel nuts should be tightened using the torque of 270 Nm - M18x1.5 nuts.

TABLE 5.1 Selection of spanner arm length

WHEEL TIGHTENING TORQUE	BODY WEIGHT (F)	ARM LENGTH (L)
[Nm]	[kg]	[m]
270	90	0.30
	77	0.35
	67	0.40
	60	0.45

ATTENTION

Wheel nuts must not be tightened with impact wrench because of danger of exceeding permissible tightening torque, the consequence of which may be breaking the connection thread or breaking off the hub pin.

The greatest precision is achieved using a torque spanner. Before commencing work, ensure that correct tightening torque value is set.

5.2.5 CHECKING AIR PRESSURE IN TYRES, EVALUATING TECHNICAL CONDITION OF TYRES AND STEEL WHEELS

**TIP**

Tyre pressure values are specified in information decal, placed on wheel or on the frame above machine wheel.

Tyre pressure should be checked each time after changing spare wheel and not less than every month. In the event of intensive use, air pressure in tyres should be checked more frequently. During this time, the trailer must be unloaded. Checking should be done before travelling when tyres are not heated, or after an extended period of parking.

**DANGER**

Damaged tyres or wheels may be the cause of a serious accident.

While checking pressure pay attention to technical condition of wheels and tyres. Look carefully at tyre sides and check the condition of tread. In case of mechanical damage consult the nearest tyre service and check whether the tyre defect requires tyre replacement. Wheels should be inspected with regard to distortion, breaking of material, breaking of welds, corrosion, especially in the area of welds and contact with tyre.

**INSPECTION**

- *Every month of use.*
- *Every week during intensive work.*

5.2.6 CHECKING THICKNESS OF BRAKE SHOE LININGS.

During use of trailer, friction lining of brake drums is subject to wear. In such a case, the complete brake shoes should be replaced with new ones. Excessive wear of brake shoes is the condition in which the thickness of linings which are glued or riveted to steel structures of brake shoes is smaller than the minimum value. This condition is indicated by extended cylinder piston stroke. Check technical condition of brake shoe linings through inspection openings (3) – figure (5.6).

**TIP**

Minimum thickness of brake shoe linings is 2 mm.

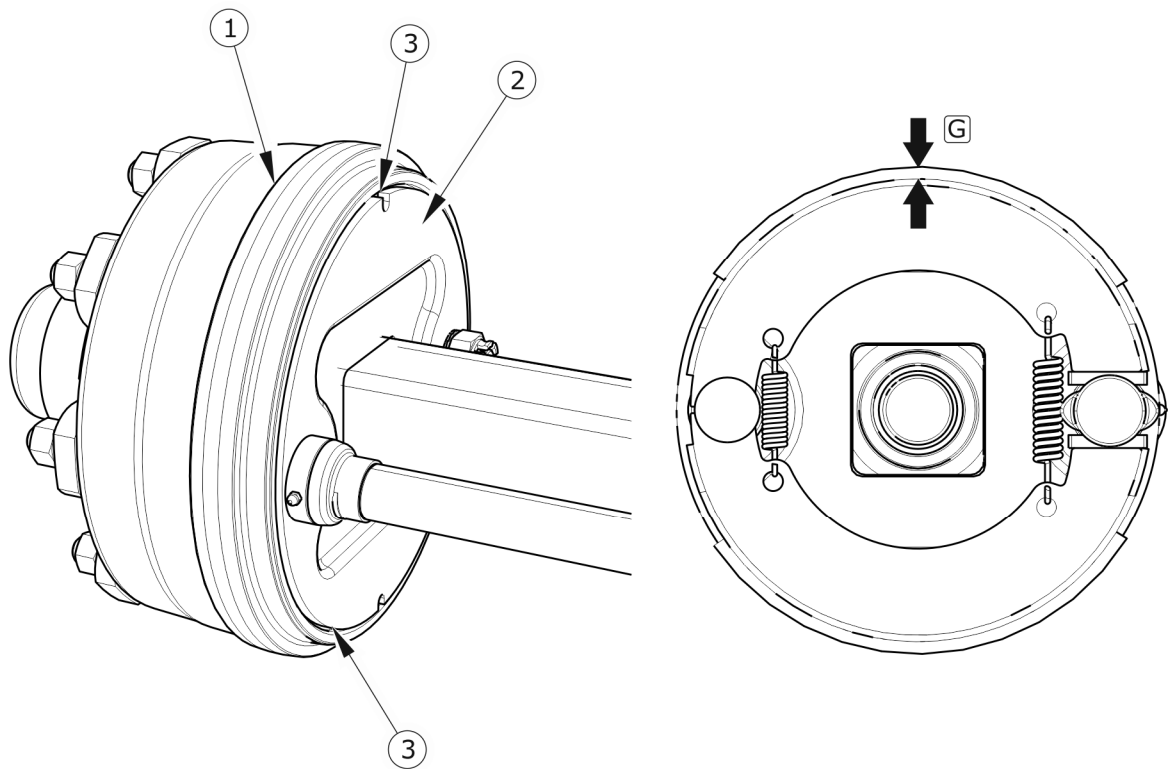

FIGURE 5.6 *Checking brake shoe linings*

(1) brake drum, (2) disc, (3) inspection openings, (G) thickness of brake shoe lining



INSPECTION

Thickness of brake shoe linings should be checked every 6 months.

5.2.7 ADJUSTMENT OF MECHANICAL BRAKES

Preliminary information

Considerable wear of brake shoe linings results in increased brake cylinder rod stroke and worse braking efficiency.



TIP

Correct brake cylinder piston stroke should be within the range of 25 – 45 mm.

During braking, the brake cylinder piston stroke should be within the specified operating range and the angle between brake cylinder piston and expander arm should be about 90° – compare figure (5.8).

Braking force decreases also when the operating angle of the brake cylinder piston (5), in relation to the expander arm (1), is wrong – figure (5.7). In order to obtain the optimum mechanical operating angle, the cylinder piston fork (6) must be installed on the expander arm (1) in such a manner as to ensure that the operating angle at full braking is about 90° .



ATTENTION

Incorrectly adjusted brake may cause rubbing of brake shoes against brake drums, which may lead to faster wear of brake linings and/or brake overheating.

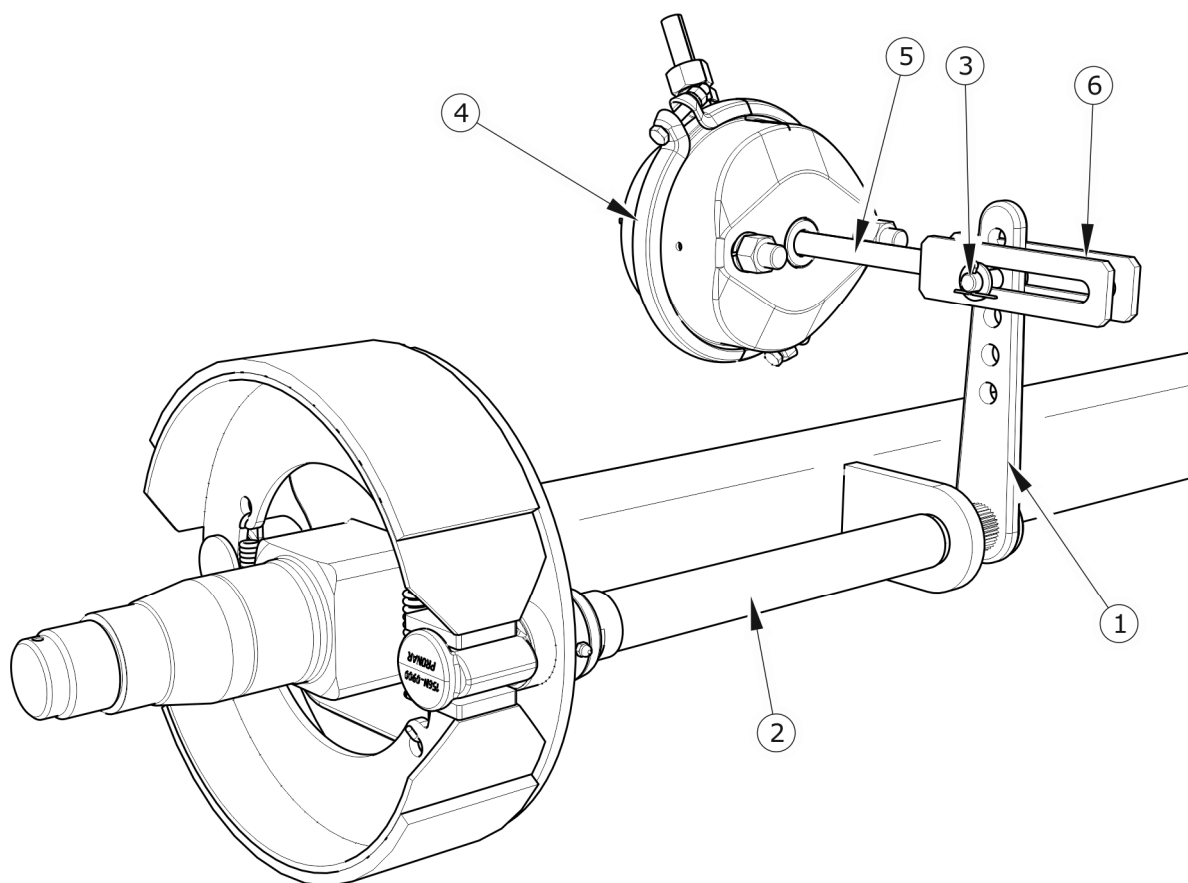

FIGURE 5.7 Design of wheel axle brake

(1) expander arm, (2) expander shaft, (3) fork pin, (4) brake cylinder, (5) cylinder rod, (6) cylinder fork

TABLE 5.2 Operating data of pneumatic cylinder

NOMINAL CYLINDER STROKE L [mm]	MINIMUM CYLINDER STROKE L _{MIN} [mm]	MAXIMUM CYLINDER STROKE L _{MAX} [mm]
75	25	45



INSPECTION

- *Check technical condition of brake every 6 months.*

The inspection involves measuring the extension length of each brake cylinder rod while braking at parking. If the brake cylinder rod stroke exceeds the maximum value (45 mm), the braking system should be adjusted.

Scope of maintenance activities

- ➔ Hitch trailer to tractor.
- ➔ Turn off tractor engine and remove key from ignition.
- ➔ Immobilise the tractor with parking brake.
- ➔ Make sure that the trailer's brakes are not engaged.
- ➔ Secure the trailer with wheel chocks.
- ➔ Make a line (A) on the brake cylinder piston (1) to indicate the position of the maximum withdrawal of the brake cylinder piston – figure (5.8).
- ➔ Press the tractor brake pedal and mark the position of the maximum extension of the brake cylinder piston rod with a line (B).
- ➔ Measure the distance between lines (A) and (B). If the brake cylinder rod stroke is outside the proper operating range, adjust the expander arm.
- ➔ Dismantle brake cylinder fork pin.
- ➔ Remember or mark the original position (5) of brake cylinder fork (4) in expander arm opening (3).

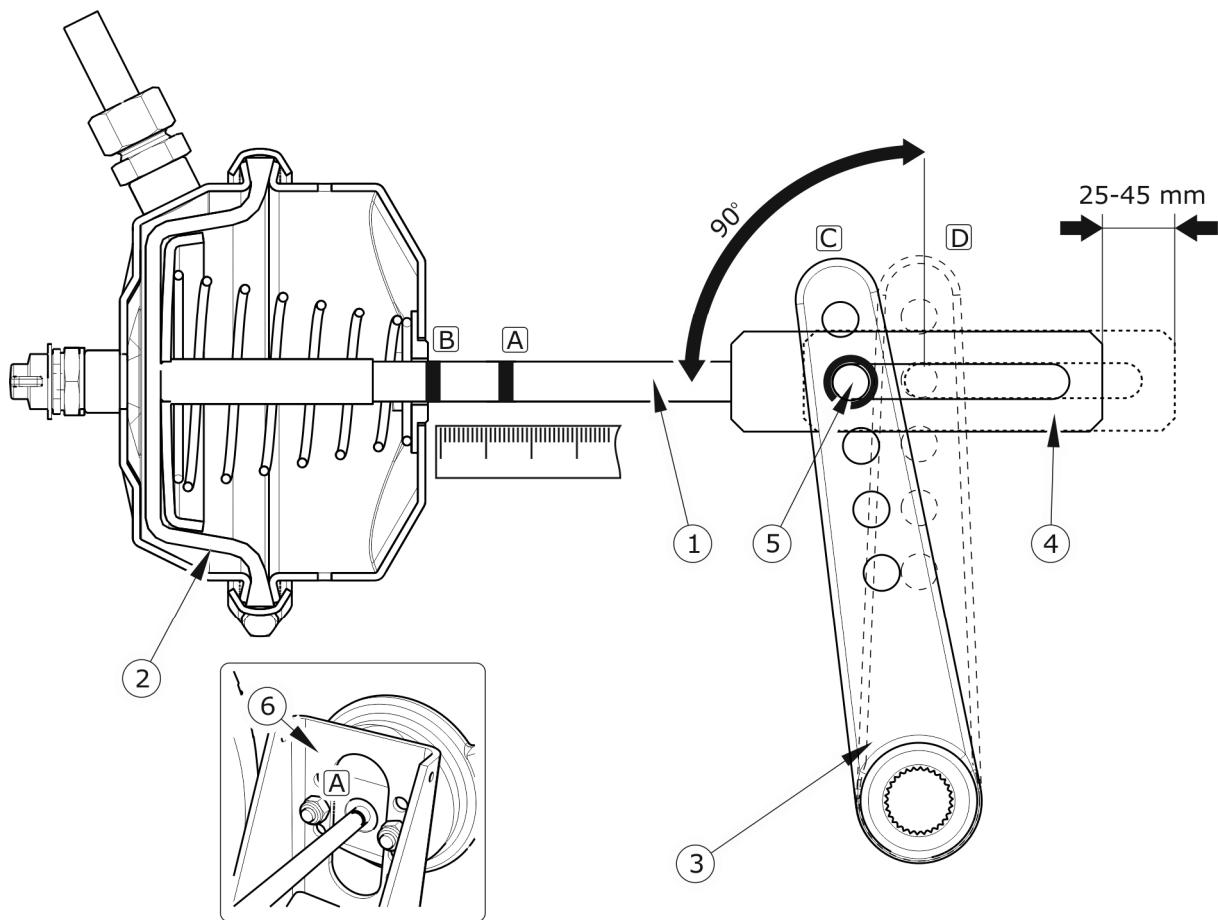

FIGURE 5.8 Principle of brake adjustment

(1) brake cylinder rod, (2) brake cylinder membrane, (3) expander arm, (4) cylinder fork, (5) position of fork pin, (6) brake cylinder bracket, (A) mark on the brake cylinder at brake release position, (B) mark on the brake cylinder at full braking position, (C) position of arm at brake release position, (D) position of arm at full braking position

- ➔ Check if the brake cylinder piston rod moves freely and within the whole nominal range.
- ➔ Check if the brake cylinder vent holes are not blocked with impurities and that there is no water or ice inside the brake cylinder. Check if the brake cylinder is correctly installed.
- ➔ Clean the brake cylinder. If necessary, defrost the brake cylinder and drain water through the unblocked vent holes. Replace damaged brake cylinder with a new one. When installing the brake cylinder, maintain its original position with regard to bracket (6).

- ➔ Dismantle the expansion ring securing the expander arm.
- ➔ Shift the expander arm to align the marked expander arm opening with the cylinder fork opening.
 - ⇒ During adjustment, membrane (2) must rest on the rear wall of the brake cylinder – compare figure (5.8).
- ➔ Install the brake cylinder fork pin and washers and secure the pin with cotter pins.
- ➔ Repeat adjustment activities for the other brake cylinder on the same axle.
- ➔ Engage the brake.
- ➔ Remove previous marks and measure the brake cylinder piston rod stroke again.
- ➔ If the brake cylinder piston rod stroke is outside the proper operating range, repeat the adjustment.

INSPECTION



- *Every 6 months.*
- *After repair of braking system.*
- *In case of uneven trailer wheels braking.*

ATTENTION



The positions for fixing the brake cylinder in the bracket openings and the brake cylinder pin in the expander arm are determined by the Manufacturer and must not be changed.

Each time when dismantling the pin or brake cylinder, the original fixing position should be marked.

5.2.8 REPLACEMENT OF PARKING BRAKE CABLE AND ADJUSTMENT OF CABLE TENSION.

Proper operation of the parking brake is dependent on the effectiveness of the axle brake and the correct brake cable tension.

Replacing the parking brake cable

- ➔ Hitch trailer to tractor. Park machine and tractor on level surface.
- ➔ Prevent the trailer from rolling by placing chocks under the wheels. Immobilise tractor with parking brake.
- ➔ Loosen nuts (2) of cable clamps and dismantle the cable.
- ➔ Grease the bolt mechanism of the parking brake and pins of cable guide rollers – see section *LUBRICATION*.
- ➔ Install new cable, adjust cable tension.

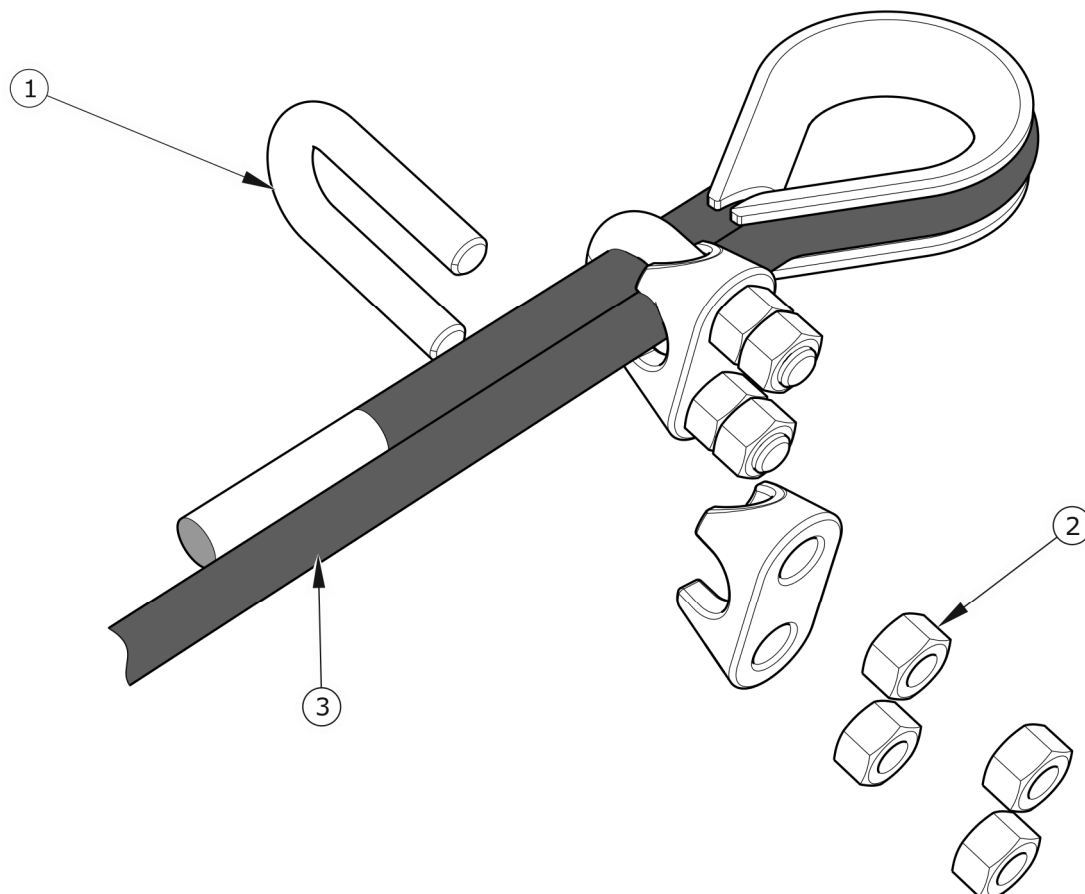

FIGURE 5.9 *Installing the parking brake cable*

(1) U-bolt clamp, (2) nuts of clamps, (3) handbrake cable

Adjustment of parking brake cable tension

- ➔ Hitch trailer to tractor. Park machine and tractor on level surface.
- ➔ Prevent the trailer from rolling by placing chocks under the wheels. Immobilise tractor with parking brake.
- ➔ Fully unscrew the bolt of the handbrake mechanism.
- ➔ Loosen all nuts (2) – figure (5.9) of handbrake cable clamps on the brake mechanism side.
- ➔ Tighten cable and tighten clamps.

Length of parking brake cable should be so selected that at total release of working and parking brake the cable would be loose and hanging by 1 - 2 cm.



ATTENTION

Parking brake cable clamps must be installed as shown in figure (5.9), i.e. clamp bracket (2) must be installed on the side of the shorter brake cable section. Tighten nuts using tightening torque given in table TIGHTENING TORQUE FOR NUT AND BOLT CONNECTIONS

Adjustment of parking brake cable tension should be conducted in the event of:

- stretching of cable,
- loosening of parking brake cable clamps
- after adjustment of axle brakes,
- after repairs of axle brake system,
- after repairs of parking brake system.

Before the adjustment, make certain that the axle brake is correctly adjusted and is functioning properly.



INSPECTION

- *Every 12 months.*

5.3 PNEUMATIC SYSTEM MAINTENANCE

5.3.1 PRELIMINARY INFORMATION

Work connected with repair, replacement or regeneration of system components (brake cylinders, conduits, control valve, braking force regulator, etc.) should be entrusted to specialist establishments, having the appropriate technology and qualifications for this type of work.

The duties of the operator connected with the pneumatic system maintenance include:

- checking tightness and visual inspection of the system,
- cleaning the air filter (filters),
- draining water from air tank,
- cleaning drain valve,
- cleaning and maintaining pneumatic conduit connections,



DANGER

Do not use the trailer when brake system is out of order.

5.3.2 CHECKING TIGHTNESS

Checking air tightness of pneumatic system

- ➔ Hitch trailer to tractor. Park machine and tractor on level surface.
- ➔ Prevent the trailer from rolling by placing chocks under the wheels. Immobilise tractor and trailer with parking brake.
- ➔ Start the tractor in order to supplement air in the trailer braking system tank.
 - ⇒ In single line systems air pressure should amount to approx. 5.8 to 6.5 bar.
 - ⇒ In double conduit systems air pressure should amount to approx. 5.8 bar.

- ➔ Turn off tractor engine.
- ➔ Check system components by releasing brake pedal in tractor.
 - ⇒ Pay particular attention to conduit connections and brake cylinders.
- ➔ Repeat the system check with depressed tractor brake pedal.
 - ⇒ The help of a second person is required.

In the event of the appearance of leaks, compressed air will escape at the places of damage, with a characteristic hiss. Lack of system tightness may be detected by covering checked elements with washing fluid or other foaming preparations, which will not react aggressively with the system components. It is recommended to use preparations commercially available designed to facilitate detecting air leaks. Damaged components should be replaced or repaired. If leaks appear at connections then tighten the connections. If air continues to escape, replace connection components or seals with new ones.

INSPECTION



- *after travelling the first 1,000 km.*
- *Each time after making repairs or changing system components,*
- *Every 12 months.*

5.3.3 INSPECTION OF THE SYSTEM

During tightness inspection attention should additionally be given to technical condition and degree of cleanness of the system components. Contact of pneumatic conduit seals etc. with oil, grease, petrol etc. may cause damage and accelerate the ageing process. Bent, permanently deformed, cut or worn conduits should be replaced.

INSPECTION



- *Each time during tightness inspection.*

5.4 CLEANING THE AIR FILTERS

Depending on trailer working conditions, but not less than once in three months, take out and clean air filter elements, which are located in pneumatic system connection conduits. Inserts are used many times and are not subject to changing unless they are mechanically damaged.

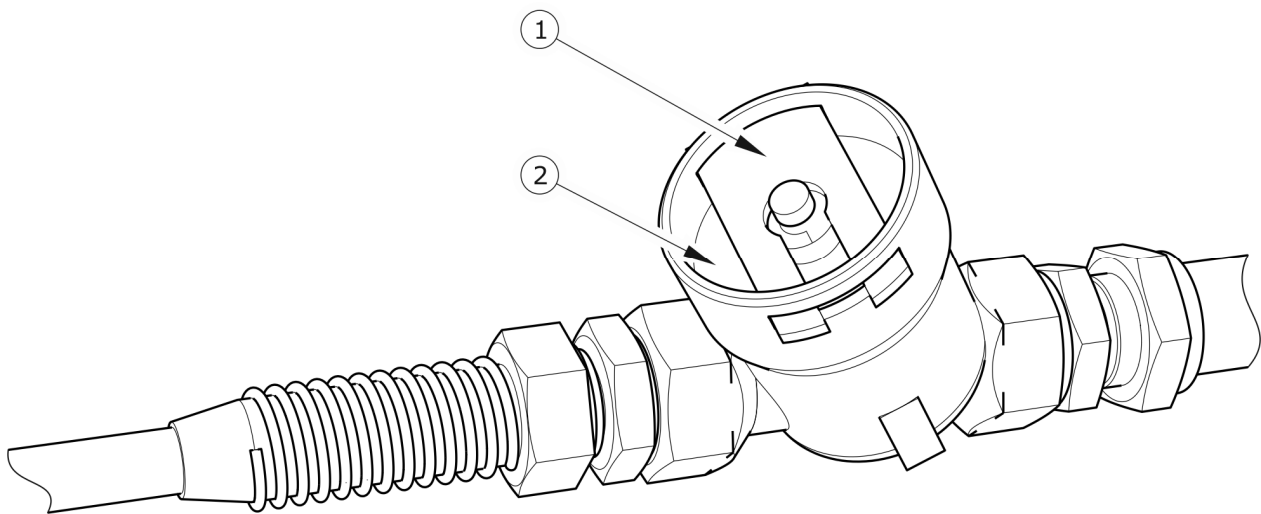

FIGURE 5.10 Air filter

(1) securing slide lock, (2) air filter cover



DANGER

Before proceeding to dismantle filter, reduce pressure in supply conduit. While dismantling the filter slide gate, hold the cover with the other hand. Stand away from filter cover vertical direction.

Scope of maintenance activities

- ➔ Reduce pressure in supply conduit.
 - ⇒ Pressure in conduit can be reduced by pressing the head of the pneumatic connection until resistance is felt.
- ➔ Remove securing slide (1).

- ➔ Hold the filter cover (2) with the other hand. After removing slide lock, the cover is pushed off by the spring located in the filter housing.
- ➔ The filter element and the filter body should be carefully cleaned and blown through with compressed air. Assembly should be done in reverse order.



INSPECTION

- *Every 3 months.*

5.4.1 DRAINING WATER FROM AIR TANK

Scope of maintenance activities

- ➔ Tilt drain valve stem (2) located in the lower part of tank (1).
- ➔ The compressed air in the tank causes the removal of water to the exterior.
- ➔ Released valve stem should automatically close and stop flow of air from the tank.
- ➔ In the event, that the valve stem resists returning to its setting, then the whole drain valve must be unscrewed and cleaned, or replaced (if it is damaged) - see section *CLEANING DRAIN VALVE*.

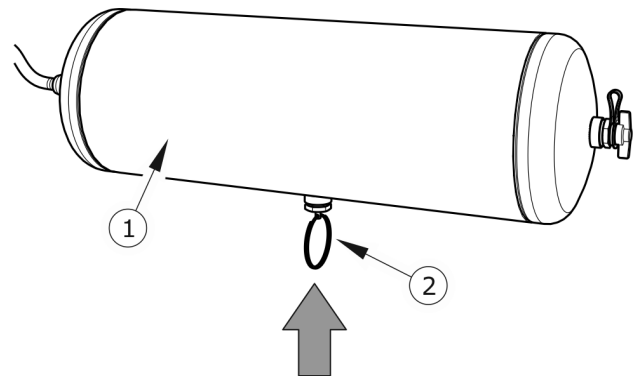

FIGURE 5.11 *Draining water from the tank*

(1) air tank, (2) drain valve

5.4.2 CLEANING DRAIN VALVE



DANGER

Release air from the air tank before dismantling drain valve.

Required maintenance actions

- ➔ Completely reduce pressure in air tank.
 - ⇒ Reduction of pressure in tank is achieved by tilting the drain valve stem.
- ➔ Unscrew both valves.
- ➔ Clean the valve and blow it with compressed air.
- ➔ Change copper seals.
- ➔ Screw valves in, fill tanks with air, check tightness.



INSPECTION

- *Every 12 months (before winter).*

5.4.3 CLEANING AND MAINTAINING PNEUMATIC CONDUIT CONNECTIONS AND PNEUMATIC SOCKETS



DANGER

Unreliable and dirty trailer connections may cause unreliability and faulty functioning of braking system.

Connection with damaged body should be replaced. In the event of damage to cover or seal, change these elements for new reliable elements. Contact of pneumatic connection seals with oils, grease, petrol etc. may cause damage and accelerate ageing process.

If the trailer is unhitched from the tractor, connections should be protected by cover or placed in their designated socket. Before the winter, it is recommended to preserve the seal with special preparations (e.g. silicon grease for rubber elements).

Each time before hitching the machine, inspect technical condition and cleanness of connectors and sockets in tractor. If necessary, clean or repair tractor sockets.

**INSPECTION**

- *Each time before hitching trailer to tractor.*

5.5 HYDRAULIC SYSTEM MAINTENANCE

5.5.1 PRELIMINARY INFORMATION

Work connected with the repair, replacement or regeneration of hydraulic system components should be entrusted to specialist establishments which have the appropriate technology and qualifications for this type of work.

**TIP**

Bleeding of the hydraulic system is not required during normal operation of the trailer.

The duties of the operator connected with the maintenance of hydraulic systems include:

- checking tightness and visual inspection of the system,
- checking technical condition of hydraulic connections.

5.5.2 CHECKING HYDRAULIC SYSTEM TIGHTNESS

Required maintenance actions

- ➔ Hitch trailer to tractor.
- ➔ Connect conduits of hydraulic braking system according to the recommendations in the Operator's Manual.
- ➔ Clean connectors and hydraulic cylinders.
- ➔ Start the tractor's engine and depress brake pedal several times. Leave the cylinders in the maximally extended position.
- ➔ Switch off tractor engine and check hydraulic cylinders.

If oil leak is detected on hydraulic cylinder body, ascertain origin of leak. Inspect seals when hydraulic cylinder is completely extended. Minimum leaks are permissible with symptoms of "sweating". However, if leaks in the form of "droplets" are noticed, stop using the trailer. If leaks appear at connections then tighten the connections. If the leak at connections is not removed, replace conduit, connector and seals (depending on place of leakage).

**INSPECTION**

- *After the first week of use.*
- *Every 12 months.*

5.5.3 CHECKING TECHNICAL CONDITION OF HYDRAULIC COUPLERS AND SOCKETS.

Hydraulic connections must be technically reliable and kept in a clean condition. Each time before connecting, check if sockets in tractor are maintained in good working condition. Hydraulic systems of the tractor and trailer are sensitive to the presence of permanent contamination, which may cause damage to precision system components.

**INSPECTION**

- *Each time before hitching trailer to tractor.*

5.5.4 REPLACEMENT OF HYDRAULIC CONDUITS

**INSPECTION**

- *Every 4 years,*

Rubber hydraulic conduits must be replaced every 4 years regardless of their technical condition. This should be done in specialised workshops.

5.6 LUBRICATION

Trailer lubrication should be performed with the aid of a manually or foot operated grease gun, filled with recommended grease. Before commencing work insofar as is possible remove old grease and other contamination. Remove and wipe off excess oil or grease.

Change of grease in hub bearings should be entrusted to specialised service points, equipped with the appropriate tools. According to the recommendations of the axle Manufacturer, dismantle the entire hub, remove the bearing and individual sealing rings. After careful washing and inspection, mount lubricated elements. If necessary, bearing and seals should be replaced with new parts. Lubrication of axle bearings shall be performed at least once in 2 years.

TABLE 5.3 *Lubrication schedule*

ITEM	LUBRICATION POINT	NUMBER OF LUBRICATION POINTS	TYPE OF GREASE	FREQUENCY
1	Hub bearing	12	A	24M
2	Drawbar eye	1	B	14D
3	Handbrake mechanism	1	A	6M
4	Handbrake cable guide wheel axle	2	A	6M
5	Expander shaft slide sleeve	6	A	3M
6	Drawbar pin	2	B	3M
7	Leaf springs	6	C	3M
8	Leaf spring sliding surfaces	6	B	1M
9	Leaf spring pin	6	B	1M

Lubrication periods – M months, D – days

(1) – grease every 3 months or each time before intensive work

TABLE 5.4 *Recommended lubricants*

MARKING ACCORDING TO TAB. (5.3)	DESCRIPTION
A	Machine general-purpose grease (lithium, lime).
B	Grease for heavily loaded elements with addition of MoS ₂ or graphite.
C	Anti-corrosion and penetrating preparation in aerosol.

Empty grease or oil containers should be disposed of according to the recommendations of the lubricant Manufacturer.

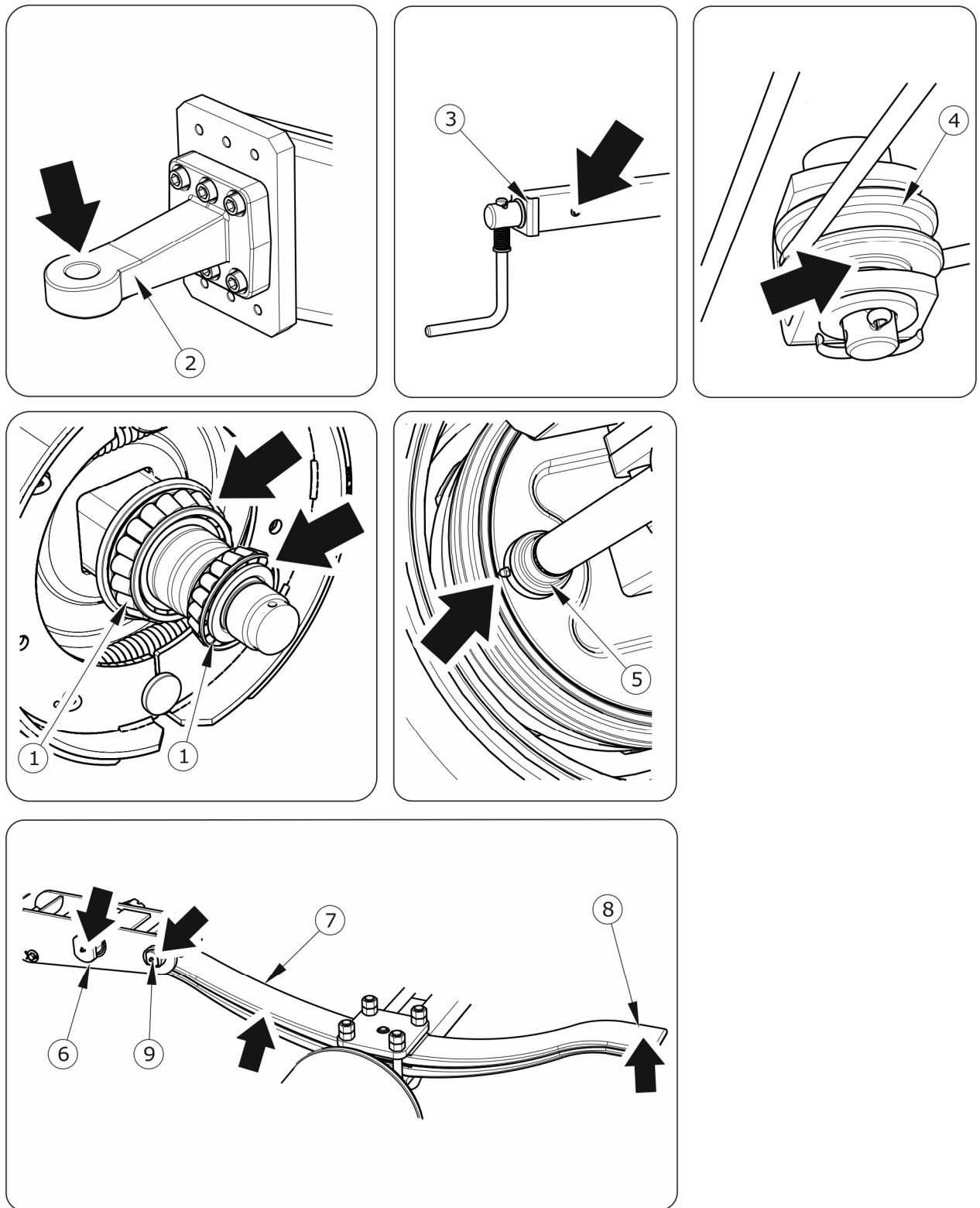

FIGURE 5.12 Trailer's lubrication points

**TIP**

Number of lubrication points and subassemblies requiring lubrication specified in table (5.3) LUBRICATION SCHEDULE depend on the trailer version.

Locations of grease nipples and areas requiring lubrication are indicated by black arrows in figure (5.12).

5.6.1 CONSUMABLES**Hydraulic oil**

Always adhere to the principle that the oil in the trailer hydraulic system and in the tractor hydraulic system are of the same type. In the event of application of different types of oil make certain that both hydraulic substances may be mixed together. Application of different oil types may cause damage to trailer or tractor. In a new machine, the hydraulic system is filled with L HL32 Lotos hydraulic oil.

If it is necessary to change hydraulic oil for another oil, check the recommendations of the oil Manufacturer very carefully. If it is recommended to flush the system with the appropriate preparation, then comply with these recommendations. Attention should be given, so that chemical substances used for this purpose do not damage the materials of the hydraulic system. During normal trailer use, change of hydraulic oil is not necessary, but if required, this operation should be entrusted to a specialist service point.

TABLE 5.5 *L-HL 32 Lotos hydraulic oil characteristics*

ITEM	NAME	UNIT	VALUE
1	ISO 3448VG viscosity classification	-	32
2	Kinematic viscosity at 40°C	mm ² /s	28.8 – 35.2
3	ISO 6743/99 quality classification	-	HL
4	DIN 51502 quality classification	-	HL
5	Flash-point	C	230

Because of its composition, the oil is not classified as a dangerous substance, however long-term action on the skin or eyes may cause irritation. In the event of contact of oil with skin

wash the place of contact with water and soap. Do NOT apply organic solvents (petrol, kerosene). Contaminated clothing should be changed to prevent access of oil to skin. In the event of contact of oil with eye, rinse with large quantity of water and in the event of the occurrence of irritation consult a doctor. Hydraulic oil in normal conditions is not harmful to the respiratory tract. A hazard only occurs when oil is strongly atomised (oil vapour), or in the case of fire during which toxic compounds may be released.

**DANGER**

Oil fires should be quenched with the use of carbon dioxide, foam or steam extinguishers. Do not use water to quench oil fires.

Lubricants

For heavily loaded parts it is recommended to apply lithium greases with addition of molybdenum disulphide (MOS₂) or graphite. In the case of less loaded sub-assemblies the application of general purpose machine greases is recommended, which contain anticorrosion additives and have significant resistance to being washed away by water. Aerosol preparations (silicon greases and anticorrosive-lubricating substances) should have similar characteristics.

Before using the greases, read the information leaflet for a given product. In particular, the principles of safety and handling of the lubricant and method of disposal (waste containers, contaminated rags, etc.) are essential. Information leaflet (product sheet) should be stored together with the grease.

5.7 TRAILER CLEANING

- The trailer should be cleaned as needed. Before using pressure washer the user is obliged to acquaint himself with the operating principles and recommendations concerning safe use of this equipment.
- The trailer only be cleaned with clean running water. Cleaning detergents with neutral pH may be used, which do not react aggressively with the trailer's structural elements.

- Using pressure washer increases washing effectiveness, but particular care must be taken during work. During washing, washer nozzle may not be closer than 50 cm from the surface being cleaned.
- Water temperature should not exceed 55 °C.
- Do not direct water stream directly at system and equipment elements of trailer i.e. control valve, braking force regulator, brake cylinders, hydraulic cylinders, pneumatic, electric and hydraulic plugs, lights, electrical connections, information and warning decals, identification plates, line connections, trailer lubrication points, leaf springs and drawbar shock absorber, etc. High pressure water jets may get inside the machine and cause mechanical damage or corrosion.
- For cleaning and maintenance of plastic coated surfaces it is recommended to use clean water or special preparations designed for this purpose.
- Do not apply organic solvents, preparations of unknown origin or other substances, which may cause damage to lacquered, rubber or plastic surfaces. In the event of doubt it is recommended to make a test on an unseen surface area.
- Surfaces smeared with oil or grease should be cleaned by application of benzene or other degreasing agents and then washed with clean water with added detergent. Comply with recommendations of the Manufacturer of cleaning agents.
- Detergents should be kept in original containers, optionally in replacement containers, but very clearly marked. Preparations may not be stored in food and drink containers.
- Ensure cleanliness of elastic conduits and seals. The plastic from which these elements are made may be susceptible to organic substances and some detergents. As a result of long-term reaction of some substances, the ageing process may be accelerated and risk of damage increased. Rubber elements

**DANGER**

Carefully read the instructions for application of detergents and maintenance preparations.

While washing with detergents wear appropriate protective clothing and goggles protecting against splashing.

should be maintained with the aid of special preparations after previous thorough washing.

- Observe environmental protection principles and wash trailer in a place designed for this purpose.
- Washing and drying the trailer must take place at temperatures above 0°C.
- Leaf springs should be cleaned using a hard brush. The space between spring leaves should be blown using compressed air.

5.8 STORAGE

- Trailer should be kept in a closed or roofed building.
- If the machine will not be used for a long time, it is essential to protect it from adverse weather conditions, especially those which initiate corrosion of steel, have aggressive impact on anticorrosion coating and accelerate tyre ageing. During this time the machine must be unloaded. Trailer should be very carefully washed and dried.
- Corroded places should be cleaned of rust, degreased and protected using undercoat paint and then painted with surface paint according to colour scheme.
- In the event of a prolonged work stoppage, it is essential to lubricate all components regardless of the date of the last lubrication.
- Wheel rims and tyres should be carefully washed and dried. During a longer storage of unused trailer it is recommended that the machine should be moved a bit once every 2 - 3 weeks in order to change the place of contact of tyres with the ground. The tyres will not be deformed and maintain proper geometry. Also, tyre pressure should be inspected from time to time, and if necessary pressure should be increased to the appropriate value.

5.9 INSPECTION OF TIGHTENING TORQUE OF NUT AND BOLT CONNECTIONS

5.9.1 TIGHTENING TORQUE FOR NUT AND BOLT CONNECTIONS

TABLE 5.6 *Tightening torque for nut and bolt connections*

METRIC THREAD	8.8 ⁽¹⁾	10.9 ⁽¹⁾
	Md [Nm]	
M10	49	72
M12	85	125
M14	135	200
M16	210	310
M20	425	610
M24	730	1,050
M27	1,150	1,650
M30	1,450	2,100

(1) – resistance class according to DIN ISO 898 standard

Unless other tightening parameters are given, during maintenance repair work apply appropriate torque to tighten nut and bolt connections. Recommended tightening torque values for the most frequently used bolt and nut connections are given in table (5.6). Given values apply to non-lubricated steel bolts.



TIP

Hydraulic conduits should be tightened using torque of 50 – 70 Nm.

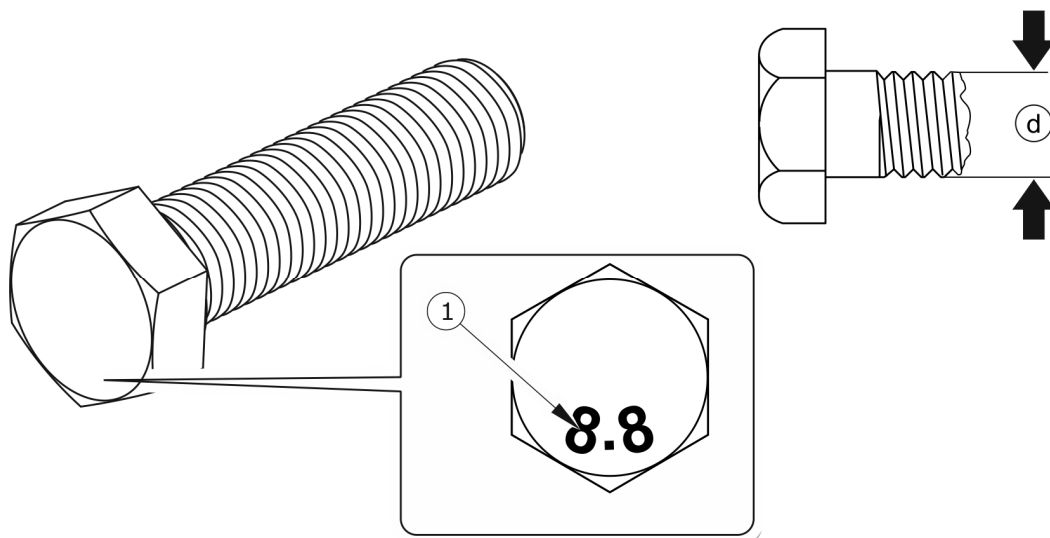

FIGURE 5.13 Bolt with metric thread

(1) strength class, (d) thread diameter

INSPECTION



- Once, after purchasing the trailer, before first use.
- Every 12 months.
- Every 3 months during intensive work.

5.10 ADJUSTMENT OF DRAWBAR POSITION

Location of the drawbar should be selected individually depending on the height of the hitch on the tractor that will pull the trailer. If possible, we recommend adjusting the tractor hitch so that the trailer drawbar is positioned horizontally while driving on a flat terrain. The height of the drawbar hitching eye can be adjusted in two ways i.e. by changing the hitching eye position or by changing the position of the drawbar with regard to the faceplate (8).

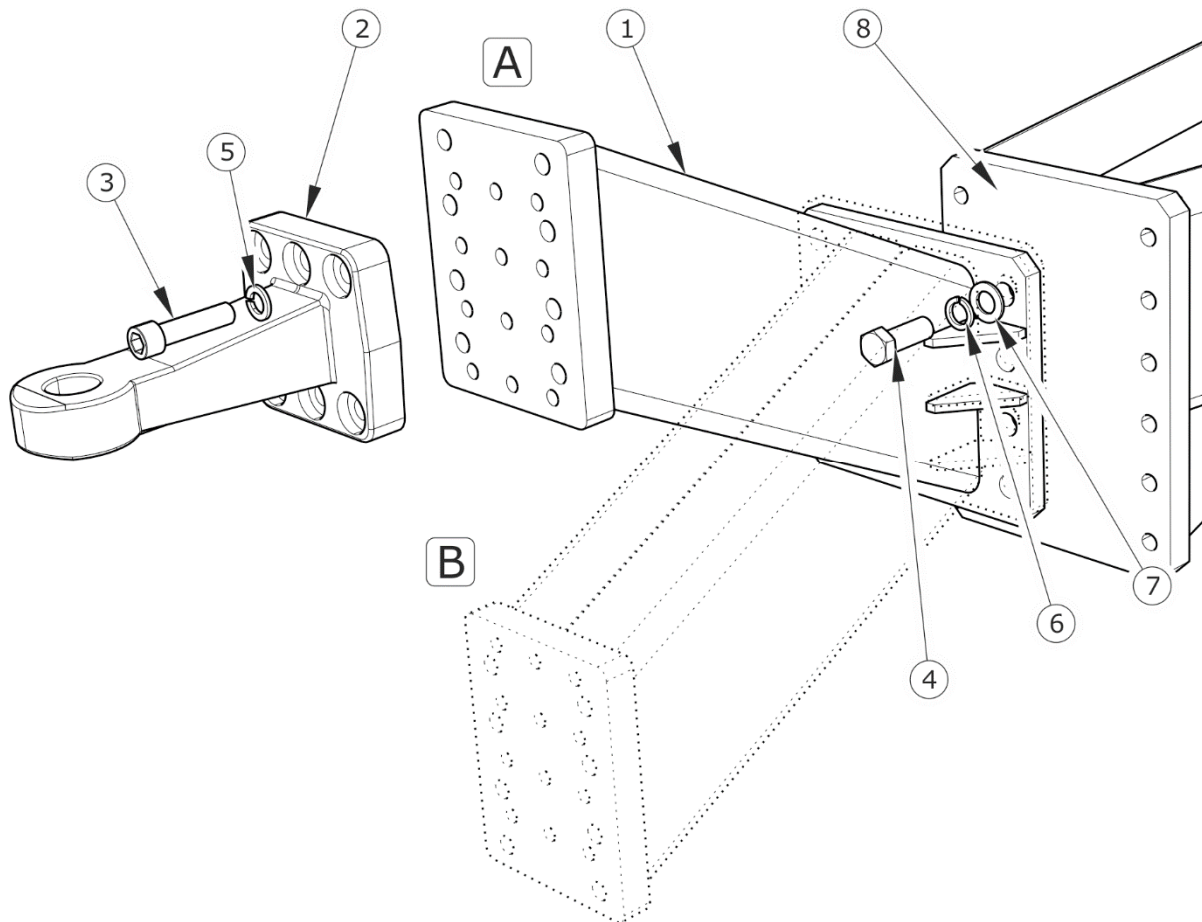

FIGURE 5.14 *Adjustment of drawbar position*

(1) drawbar, (2) drawbar hitching eye, (3), (4) bolt, (5), (6) spring washer, (7) washer, (8) faceplate, (A), (B) drawbar fixing positions

Scope of adjustment activities

- Immobilise trailer with parking brake.
- Prevent the trailer from rolling by placing chocks under the wheels.
- Drive the tractor to the trailer drawbar hitching eye.
- Unscrew the bolts fixing the drawbar hitching eye (3), dismount the drawbar hitching eye (2).
- Set the drawbar hitching eye in a new position, install spring washers and bolts.
- Tighten the bolts and check position of drawbar with regard to tractor hitch.

- ➔ If the drawbar hitching eye is still wrong, dismount the drawbar (1) and change its position with regard to the faceplate (8).

5.11 TROUBLESHOOTING

5.11.1 TROUBLESHOOTING

FAULT	REASON	REMEDY
Problem with moving off	Brake system conduits not connected	Connect brake conduits (applies to pneumatic systems)
	Applied parking brake	Release parking brake.
	Damaged pneumatic system connection conduits	Replace.
	Leaking connections	Tighten, replace washers or seal sets, replace conduits.
	Control valve or braking force regulator damaged	Check valve, repair or replace.
Noise in axle hubs	Excessive bearing slackness	Check slackness and adjust if needed
	Damaged bearings	Replace bearings
	Damaged hub parts	Replace
Poor reliability of braking system	Insufficient pressure in the system	<p>Check pressure on tractor pressure gauge, wait till compressor fills tank to required pressure.</p> <p>Damaged air compressor in tractor Repair or replace.</p> <p>Damaged brake valve in tractor. Repair or replace.</p> <p>Leaking system conduits or connections. Check system for tightness.</p>
Excessive heating of axle hubs	Incorrect main or parking brake adjustment	Regulate positions of expander arms

FAULT	REASON	REMEDY
	Worn brake linings	Change brake shoes
Incorrect hydraulic system operation	Improper hydraulic oil viscosity	Check oil quality, make sure that the oil in both machines is of the same type. If necessary change oil in tractor or in trailer.
	Insufficient tractor hydraulic pump output, damaged tractor hydraulic pump.	Check tractor hydraulic pump.
	Damaged or contaminated cylinder	Check cylinder piston rod (bending, corrosion), check cylinder for tightness (cylinder piston rod seal), if necessary, repair or replace the cylinder.
	Excessive cylinder loading	Check and reduce cylinder load, if necessary
	Damaged hydraulic conduits	Check and ascertain that hydraulic conduits are tight, not fractured and properly tightened. If necessary, replace or tighten.
Excessive wear of left and right tyre shoulders on both sides.	<p>Too low air pressure in tyres.</p> <p>Excessive speed of travel of loaded trailer on turns.</p> <p>Too fast loss of air due to damaged wheel, valve, puncture, etc.</p>	<p>Check air pressure. Regularly check correctness of air pressure in tyres.</p> <p>Excessive loading of the trailer. Do not exceed the permissible gross weight of the trailer.</p> <p>Reduce speed of travel while driving on turns on hardened surface.</p> <p>Check wheel and valve. Replace damaged parts.</p>
Excessive wear of central part of tyre.	Excessive air pressure in tyres.	Check air pressure. Regularly check correctness of air pressure in tyres.

FAULT	REASON	REMEDY
Excessive wear of left or right tyre shoulder, on one side	Incorrect toe-in. Incorrectly positioned wheel axles.	Damaged leaf spring on one side of the suspension system. Replace leaf springs.
Worn tyre tread.	Damaged suspension system, broken leaf spring. Damaged brake system, blocking of brakes, incorrectly adjusted brake system. Too frequent and violent braking.	Check suspension system for looseness, check leaf springs. Replace damaged or worn elements. Check brake system for malfunctions. Adjust expander lever.
Side crack.	Prolonged use of tyre with low air pressure. Excessive loading of the trailer.	Regularly check air pressure in tyres. Check weight of load while loading.
Abrasions on external side edge of tyre.	Too frequent driving over sharp or high obstacles (e.g. curbs).	Control driving technique.
Damaged rim (hardening and cracking near rim), brittleness of tyre.	Incorrect braking technique. Too frequent violent braking. Damaged brake system.	Check brake system. Control braking technique. Damage occurs due to excessive heating of hub which leads to heating of wheel.

NOTES

A series of horizontal dotted lines for writing notes.



ANNEX A

TYRE	WHEEL DISC
385/55 R22.5 160F	11.75x22.5 ET= -25
15.0/70-18 TL 14PR 148A8	13x18 ET=-50
500/50-17 18PR 155A8	16.00x17 ET=-35
520/50-17 159A8	16.00x17 ET=-20

