



PRONAR SP. Z O.O.

17-210 NAREW, UL. MICKIEWICZA 101A, PODLASKIE PROVINCE

PHONE: +48 085 681 63 29

+48 085 681 64 29

+48 085 681 63 81

+48 085 681 63 82

FAX: +48 085 681 63 83

+48 085 682 71 10

www.pronar.pl

OPERATOR'S MANUAL

AGRICULTURAL TRAILER

PRONAR RC3100

TRANSLATION OF THE ORIGINAL COPY OF THE MANUAL

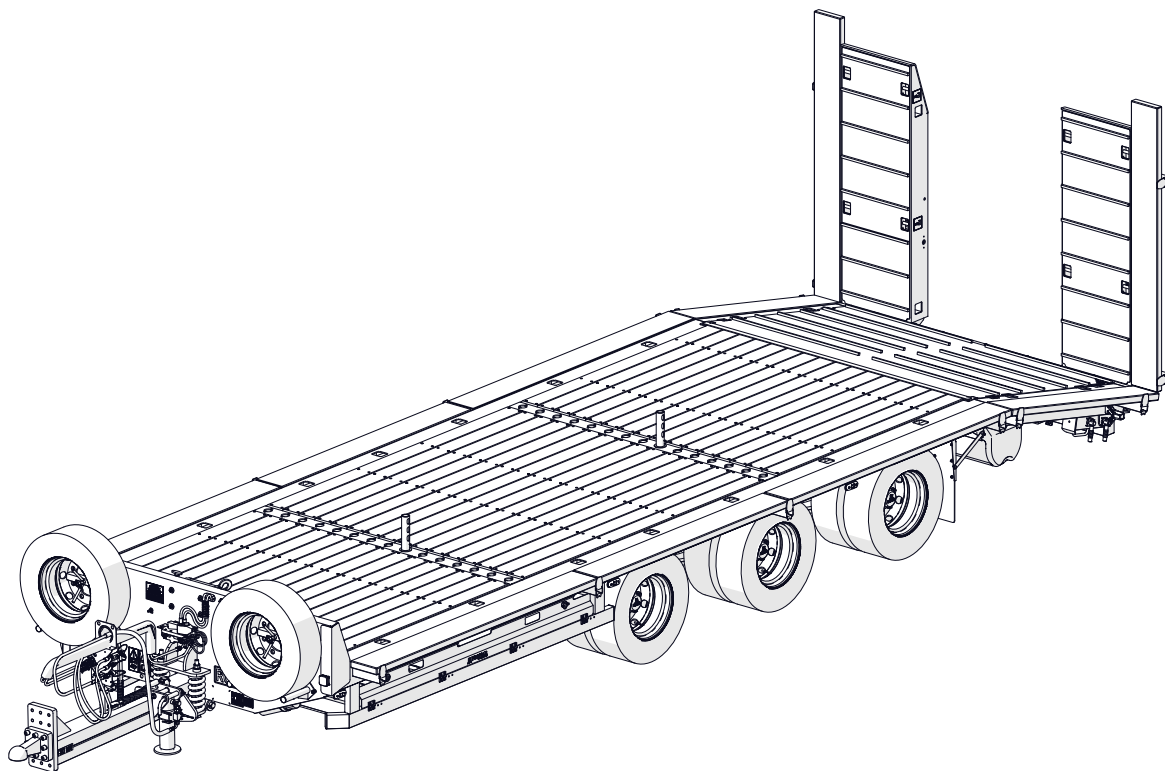

REVISION 1B

05-2021

PUBLICATION NO.: 621.01.UM.1B.EN



INTRODUCTION

INTRODUCTION

Information contained herein is current at date of publication. As a result of improvements, some numerical values and illustrations contained in this publication may not correspond to the factual specification of the machine supplied to the user. The manufacturer reserves the right to introduce design changes in machines produced that facilitate operation and improve the quality of their work, without making minor amendments to this Operator's Manual.

This Operator's Manual is an integral part of the machine's documentation. Before using the machine, the user must carefully

read this Operator's Manual and observe all recommendations. This guarantees safe operation and ensures failure-free work of the machine. The machine is designed to meet obligatory standards, documents and legal regulations currently in force.

If the information contained in the Operator's Manual needs clarification then the user should refer for assistance to the sale point where the machine was purchased or to the Manufacturer.

It is recommended that the serial number of the machine is inscribed in the spaces below after purchase of the machine.

Machine serial number

--	--	--	--	--	--	--	--	--	--	--	--	--	--	--	--	--	--	--	--	--

This Operator's Manual contains important safety and operating instructions for the machine. The Operator's Manual should be kept near the machine so that it is accessible to authorized operators.

Keep this manual for future reference. If the Operator's Manual is lost or damaged, contact the seller or the manufacturer for a copy.

The Operator's Manual is intended for the end user. For this reason, some required maintenance activities are listed in the inspection tables but the procedure is not described in this Operator's Manual. To perform these activities, call the manufacturer's authorized service centre.

U.10.1.EN

SYMBOLS APPEARING IN THIS OPERATOR'S MANUAL

DANGER

Information, descriptions of danger and precautions as well as recommendations and prohibitions associated with the safety of use are marked in the text with the sign **DANGER**. Failure to observe the instructions may endanger the machine operator's or other person's health or life.

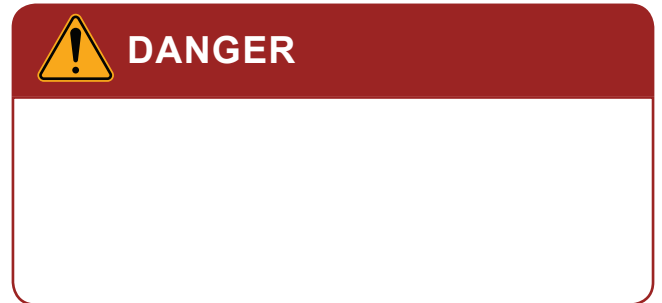

ATTENTION

Particularly important information and instructions, the observance of which is essential, are distinguished in the text by the sign **ATTENTION**. Failure to observe the instructions may lead to damage to the machine as a result of improper operation, adjustment or use.

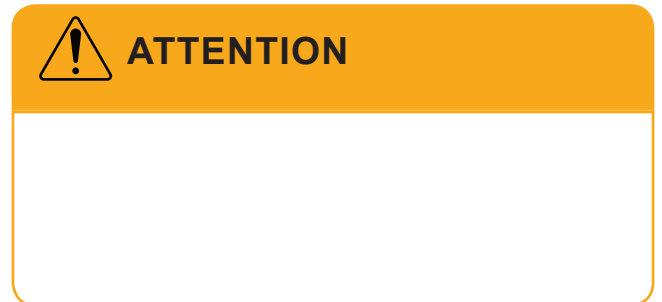

TIP

Additional tips included in the Operator's Manual describe useful advice for the machine operation and are marked with the sign **TIP**.



U.02.1.EN

DIRECTIONS USED IN THIS OPERATOR'S MANUAL

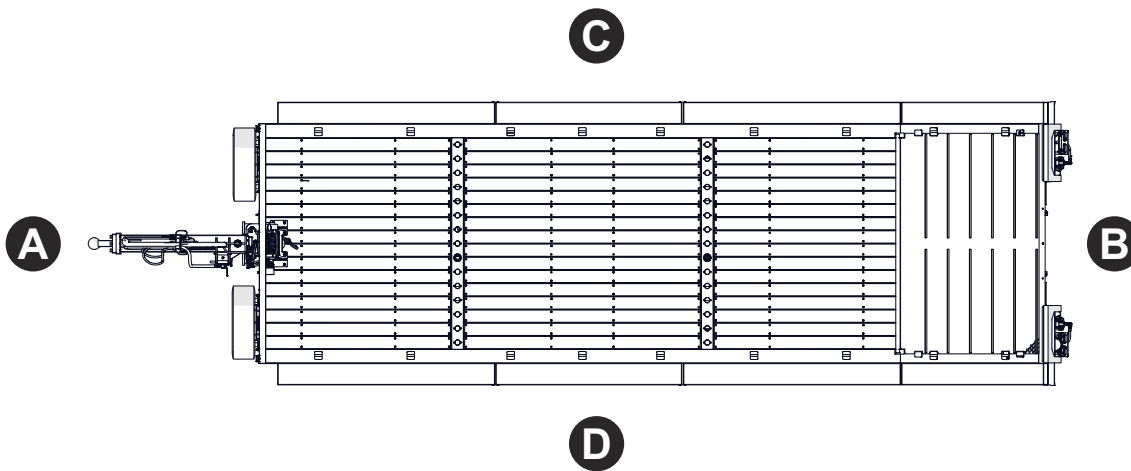

Figure 1.1 Directions used with reference to the machine

(A) - front

(B) rear

(C) right side

(D) left side

Left side – side to the left hand of the operator facing in the direction of machine's forward travel.

Right side – side to the right hand of the operator facing in the direction of machine's forward travel.

Rotation to the right – clockwise rotation of a mechanism (the operator is facing the mechanism).

Rotation to the left – counterclockwise rotation of a mechanism (the operator is facing the mechanism).

U.03.1.EN

CHECKING THE TRAILER AFTER DELIVERY

The manufacturer guarantees that the trailer is fully operational and has been checked according to quality control procedures and is ready for use. This does not release the user from an obligation to check the machine's condition after delivery and before the first use. The machine is delivered to the user completely assembled.

SCOPE OF INSPECTION ACTIVITIES

- Confirm that the specification of the delivered machine is in conformity with your order.
- Check condition of protective paint coat,
- Visually inspect the trailer's components for mechanical damage

TIP

Hand-over of the trailer to the buyer involves a detailed visual inspection and verification of the trailer operation, as well as instructing the buyer on the basic usage rules. The trailer is operated for the first time in the presence of the Seller.

resulting from, for example, incorrect transport.

- Check technical condition of tyres and tyre pressure.
- Check technical condition of elastic hydraulic and pneumatic conduits.
- Make certain that there are no hydraulic oil leaks.
- Check electrical lamps of the trailer's lighting system.

U.11.1.EN

FIRST USE OF THE TRAILER



ATTENTION

During the first use, the trailer is checked in the presence of the Seller. The Seller is obliged to conduct the training in safe and correct operation of the trailer.

- The user must read this Operator's Manual and observe all the recommendations contained in it.
- Adapt the height of the trailer drawbar to the tractor hitch.
- Conduct daily inspection of the trailer according to guidelines presented in the schedule:
- Check correctness of tightening of bolt and nut connections (in particular connections of suspension system, drawbar eye and wheels).
- Hitch the machine to tractor.
- Switch on individual lights, check correct operation of electrical system.
- Check correctness of control valve

operation.

- Perform test drive. Check the trailer's braking efficiency during driving.
- Stop tractor and turn off the engine, immobilise the tractor and trailer with parking brake.

If during test run worrying symptoms occur such as:

- excessive noise and abnormal sounds originating from the rubbing of moving elements,
- leakage and pressure drop in braking system,
- incorrect operation of brake cylinders,
- other faults,

stop operating the trailer and do not operate it until the malfunction is corrected.

If a fault cannot be rectified or the repair could void the warranty, please contact retailer for additional clarifications or to perform the repair.

U.12.2.EN



PRONAR Sp. z o.o.
ul. Mickiewicza 101 A
17-210 Narew, Polska
tel./fax (+48 85) 681 63 29, 681 63 81, 681 63 82,
681 63 84, 681 64 29
fax (+48 85) 681 63 83
http://www.pronar.pl
e-mail: pronar@pronar.pl

EC DECLARATION OF CONFORMITY OF THE MACHINERY

PRONAR Sp. z o.o. declares with full responsibility, that the machine:

Description and identification of the machinery	
Generic denomination and function:	AGRICULTURAL TRAILER
Type:	TL02
Model:	RC3100
Serial number:	
Commercial name:	PRONAR RC3100

to which this declaration relates, fulfills all the relevant provisions of the Directive **2006/42/EC** of The European Parliament and of The Council of 17 May 2006 on machinery, and amending Directive 95/16/EC (Official Journal of the EU, L 157/24 of 09.06.2006).

The person authorized to compile the technical file is the Head of Research and Development Department at PRONAR Sp. z o.o., 17-210 Narew, ul. Mickiewicza 101A, Poland.

This declaration relates exclusively to the machinery in the state in which it was placed on the market, and excludes components which are added and/or operations carried out subsequently by the final user.

Narew, the 2020-01-09

Place and date

Z-CIA DYREKTORA
d/s technicznych
CIĄGAREK
Roman [Signature]

*Full name of the empowered person
position, signature*

TABLE OF CONTENTS

INTRODUCTION

Introduction.....	2
Symbols appearing in this Operator's Manual.....	3
Directions used in this Operator's Manual.....	4
Checking the trailer after delivery.....	5
First use of the trailer.....	6

BASIC INFORMATION

1.1 Identification.....	1.2
1.2 Purpose.....	1.4
1.3 Equipment.....	1.6
1.4 Terms & Conditions of Warranty.....	1.7
1.5 Transport.....	1.8
1.6 Environmental hazards.....	1.11
1.7 Withdrawal from use.....	1.12

SAFETY ADVICE

2.1 Basic safety rules.....	2.2
2.2 Safety when hitching the machine.....	2.4
2.3 Safety rules when maintaining hydraulic system and pneumatic system.....	2.5
2.4 Safe maintenance principles.....	2.6
2.5 Safe driving.....	2.9
2.6 Loading and unloading.....	2.12
2.7 Tyres.....	2.13
2.8 Residual risk.....	2.14
2.9 Information and warning decals.....	2.15

DESIGN AND OPERATION

3.1 Technical specification.....	3.2
3.2 General design.....	3.3
3.3 Main brake.....	3.6
3.4 Parking brake.....	3.8
3.5 Hydraulic system of the ramps.....	3.9
3.6 Hydraulic support system.....	3.11
3.7 Hydraulic system of the winch.....	3.12
3.8 Electrical lighting system.....	3.14

CORRECT USE

4.1 Hitching and unhitching the trailer.....	4.2
--	-----

4.2 Unhitching.....	4.5
4.3 Operation of mechanical support.....	4.6
4.4 Hydraulic support operation.....	4.8
4.5 Lowering and rising the ramps (manual).....	4.10
4.6 Lowering and rising the ramps (hydraulic).....	4.13
4.7 Winch operation.....	4.15
4.8 Loading.....	4.17
4.9 Securing load.....	4.22
4.10 Load transport.....	4.24
4.11 Unloading.....	4.26
4.12 Proper use and maintenance of tyres.....	4.27
4.13 Trailer cleaning.....	4.28
4.14 Storage.....	4.30

TECHNICAL INSPECTION SCHEDULE

5.1 Basic information.....	5.2
5.2 Periodic inspections of the trailer.....	5.3
5.3 Preparing the trailer.....	5.6
5.4 Checking air pressure in tyres.....	5.7
5.5 Draining water from air tank.....	5.8
5.6 Inspection of connection plugs and sockets.....	5.9
5.7 Inspection of shields.....	5.10
5.8 Inspection of trailer prior to moving off.....	5.11
5.9 Air pressure measurement, inspection of tyres and wheels.....	5.12
5.10 Cleaning the air filters.....	5.13
5.11 Checking brake shoe linings for wear.....	5.14
5.12 Checking wheel axle bearings for slackness.....	5.15
5.13 Inspection of mechanical brakes.....	5.16
5.14 Cleaning the drain valve.....	5.17
5.15 Inspection of parking brake cable tension.....	5.18
5.16 Inspection of hydraulic system.....	5.20
5.17 Inspection of pneumatic system.....	5.21
5.18 Lubrication.....	5.22
5.19 Inspection of nut and bolt connections.....	5.27
5.20 Replacement of hydraulic conduits.....	5.30

MAINTENANCE

6.1	Wheel mounting and dismounting.....	6.2
6.2	Replacing the parking brake cable.....	6.3
6.3	Brakes adjustment.....	6.5
6.4	Adjustment of axle bearing slackness.....	6.7
6.5	Adjustment of drawbar eye height.....	6.8
6.6	Maintenance of electrical system and warning elements.....	6.9
6.7	Consumables.....	6.10
6.8	Troubleshooting.....	6.12

TYRE SYSTEM

SECTION 1

BASIC INFORMATION

1.1 IDENTIFICATION

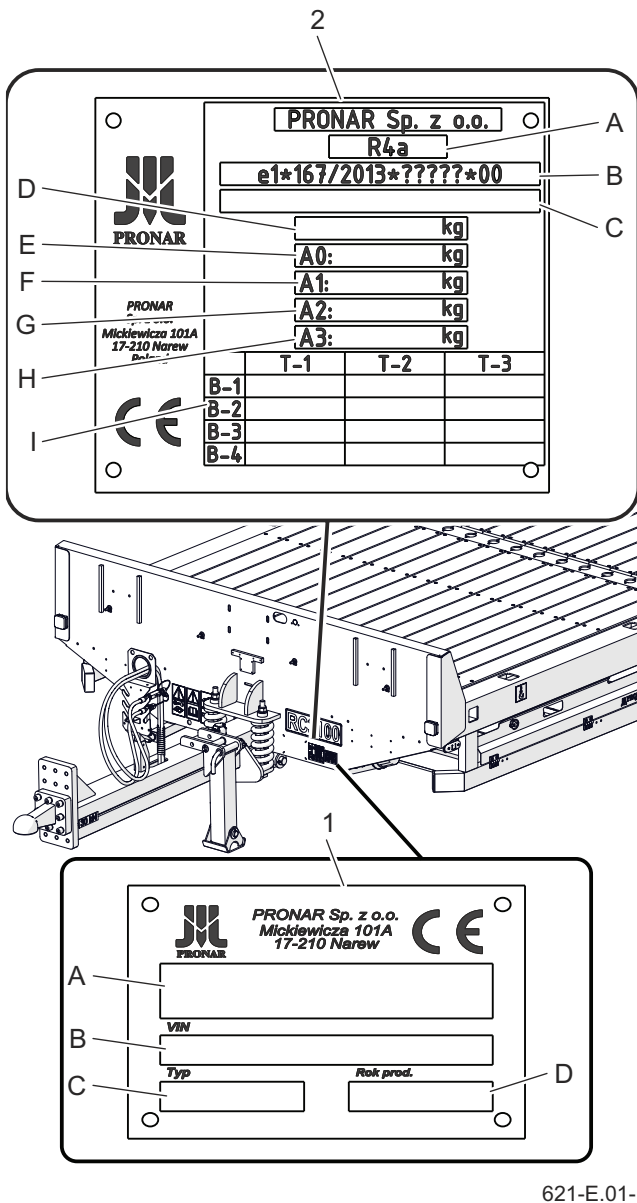

Figure 1.1 Location of the data plate
(1) data plate 1
(2) data plate 2

The trailer is marked with data plates (1) and (2) - Figure (1.1) and a serial number - Figure (1.2). The meanings of the individual fields found on the data plates are presented in the tables (1.1) and (1.2). When buying the machine check that the

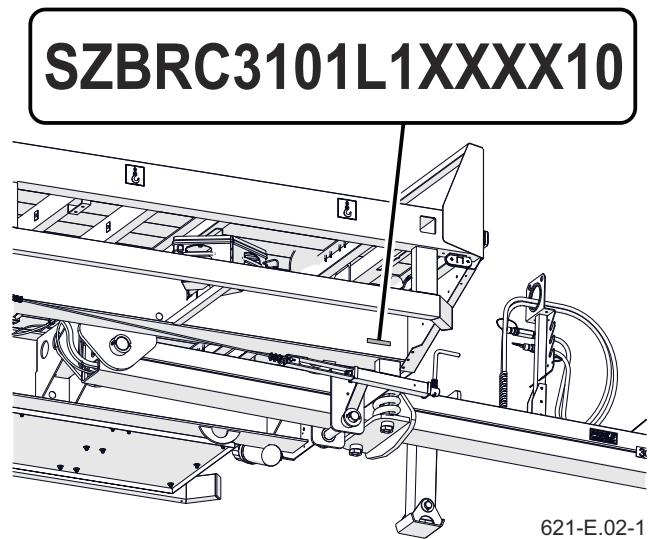

Figure 1.2 Location of serial number

Table 1.1 Markings on data plate 1

Item	Meaning
A	Machine name
B	VIN
C	Machine type
D	Year of manufacture

serial numbers on the machine agree with the number written in the *Warranty Book*, in the sales documents and in the *Operator's Manual*.

TIP

In order to contact the Service Department, the user must provide the trailer's serial number and, sometimes, serial numbers of the axles. That is why, these numbers must be inscribed in the Operator's Manual and easily available.

1.2 PURPOSE

The trailer is designed for transporting agricultural and construction machines and the loads which can be properly secured against moving during travel (loads placed in boxes, containers, on pallets etc.).

The above-mentioned loads may be transported provided that the recommendations included in this manual, especially the recommendations concerning protection of load included in Section *Securing load* are adhered to.

Transporting people, animals, bulk and hazardous materials is prohibited and regarded as contrary to the intended purpose of the trailer. The trailer must not be used for transporting long materials e.g. sawlogs.

The trailer may only be hitched to the agricultural tractors which fulfil all the requirements specified in table *Requirements for agricultural tractor*.

The brake system and the light and indicator system meet the requirements of road traffic regulations. Do NOT exceed the permissible speed of the tractor-trailer combination (the permissible speed specified by road traffic regulations in force in the country in which the trailer is used). The trailer speed must not, however, be greater than the maximum design speed



DANGER

The machine must not be used for purposes other than those for which it is intended.

- table (3.1)

Using it as intended also involves all actions connected with the safe and proper operation and maintenance of the machine. Due to the above, the user is obliged to:

- carefully read this *Operator's Manual* and the *Warranty Book* and conform with the recommendations contained in these documents,
- understand the machine's operating principle and how to operate it safely and correctly,
- adhere to the established maintenance and adjustment plans,
- comply with general safety regulations while working,
- prevent accidents,
- comply with the road traffic regulations and transport regulations in force in the given country, in which the machine is used,
- carefully read the *Operator's Manual* and comply with its recommendations,
- only hitch the trailer to an agricultural tractor which fulfils all the

requirements specified by the trailer's Manufacturer.

The machine may only be used by persons, who:

- are familiar with the contents of this publication and with the contents of the agricultural tractor Operator's

Manual,

- have been trained in trailer operation and work safety,
- have the required authorisation to drive carrying vehicles and are familiar with the road traffic regulations and transport regulations.

Table 1.3 Requirements for agricultural tractor

Contents	Unit	Requirements
Pneumatic brake system		
Pneumatic control socket	-	yellow colour according to PN-ISO 1728
Pneumatic supply socket	-	red colour according to PN-ISO 1728
Electrical system		
Supply voltage	V	12
Supply socket	-	7-pin socket according to ISO 1724
Hydraulic system		
Hydraulic oil	-	L HL 32 Lotos ⁽¹⁾
Maximum system pressure	bar / MPa	160/16
Hitching device		
Drawbar hitch or hook hitch or ball hitch	mm	45 or 50 or K80
Minimum lift capacity (vertical load) of the hitching system	kg	3,000
Other requirements		
Minimum tractor power demand	hp / kW	104 / 76.4

(1) – use of other oil is permitted on condition that it may be mixed with the oil in the trailer. Detailed information can be found on the product information card.

1.3 EQUIPMENT

STANDARD EQUIPMENT

- *Operator's Manual*
- *Warranty Book*
- *connection lead for the electrical system - spiral lead*
- mechanical system for lowering/raising the trailer's ramps
- drawbar with K80 ball drawbar eye
- side under-run protective devices
- mechanical support foot
- rear support legs
- slow-moving vehicle warning sign
- fixing lugs
- floor made of planks of coniferous wood
- double conduit pneumatic braking system with ALB regulator
- parking handbrake
- wheel chocks

ADDITIONAL AND OPTIONAL EQUIPMENT

- floor made of oak planks
- hydraulic system for lowering/raising the trailer's ramps
- drawbar with 40mm fixed drawbar eye
- drawbar with 50mm fixed drawbar eye
- drawbar with 50mm rotating drawbar eye
- toolbox
- hydraulic drawbar support
- floor extensions
- rear under-run protective device
- water tank
- mud flaps
- spare wheel (1 or 2 pcs)
- hydraulic winch
- marking signs for oversize loads
- yellow warning light
- limiter
- hubodometer

E.3.6.621.03.1.EN

1.4 TERMS & CONDITIONS OF WARRANTY

TIP

Demand that the seller carefully and precisely fills out the *Warranty Book* and warranty repair coupons. A missing date of purchase or sale point stamp may make the user ineligible for any warranty repair or refund.

PRONAR Sp. z o.o. Narew guarantees reliable operation of the machine provided that it is used as intended, as described in the *Operator's Manual*. The repair period is specified in the *Warranty Book*.

The warranty does not cover those parts and sub-assemblies of the machine which are subject to wear in normal usage conditions, regardless of the warranty period. The warranty service only applies to such cases as: mechanical damage which is not the user's fault, factory defects of parts, etc.

In the event of damage arising from:

- mechanical damage which is the user's fault, damage caused by road accidents,
- inappropriate use, adjustment or maintenance, use of the machine for

purposes other than those for which it is intended,

- use of damaged machine,
- repairs carried out by unauthorised persons, repairs carried out improperly,
- making unauthorised alterations to machine design,

the user will lose the right to warranty service.

The user is obliged to report immediately on noticing any wear in the paint coating or traces of corrosion, and to have the faults rectified whether they are covered by the warranty or not.

For detailed Terms & Conditions of Warranty, please refer to the *Warranty Book* attached to each newly purchased machine. Modifications of the machine without the written consent of the Manufacturer are prohibited. In particular, do NOT weld, drill holes in, cut or heat the main structural elements of the machine which have a direct impact on the machine operation safety.

E.3.6.621.04.1.EN

1.5 TRANSPORT

The machine is prepared for sale completely assembled and does not require packing. Packing is only required for the machine's technical documentation and some extra equipment. The trailer is delivered to the user either transported on a vehicle or, after being attached to a tractor, independently (trailer towed with a tractor).



DANGER

Incorrect use of securing measures may cause an accident.

TRANSPORT ON VEHICLE

Loading and unloading of trailer from vehicle shall be conducted using loading ramp with the aid of an agricultural tractor. During work, adhere to the general principles of occupational health and safety (OHS) applicable to reloading work. Persons operating reloading equipment must have the qualifications required to operate these machines. The trailer must be properly hitched to the tractor according to the requirements specified in this Operator's Manual. The trailer's brake must be started and checked before driving off or onto ramp.

The trailer should be attached firmly to the platform of the vehicle using straps or



DANGER

When being road transported on a motor vehicle the trailer must be mounted on the vehicle's platform in accordance with the transport safety requirements and the regulations.

Driver of the vehicle should be particularly careful during travel. This is due to the vehicle's centre of gravity shifting upwards when loaded with the machine.

Use only certified and technically reliable securing measures. Carefully read the information contained in the Operator's Manuals for the given securing measures.

chains fitted with a tightening mechanism.

Securing elements should be attached to the transport lugs designed for this purpose. Transport lugs are welded to the longitudinal members of the lower frame - figure (1.4).

Use only certified and technically reliable securing measures. Worn straps, cracked securing catches, bent or corroded hooks as well as elements damaged in a different way may be unsuitable for use. Carefully read the information in the Operator's Manual for the given securing measure. Chocks or other objects without sharp edges should be placed under the wheels of the trailer to prevent it from rolling. Trailer wheel chocks must be secured to the load platform of the vehicle in a manner preventing their movement. The quantity of securing elements (cables, straps, chains,

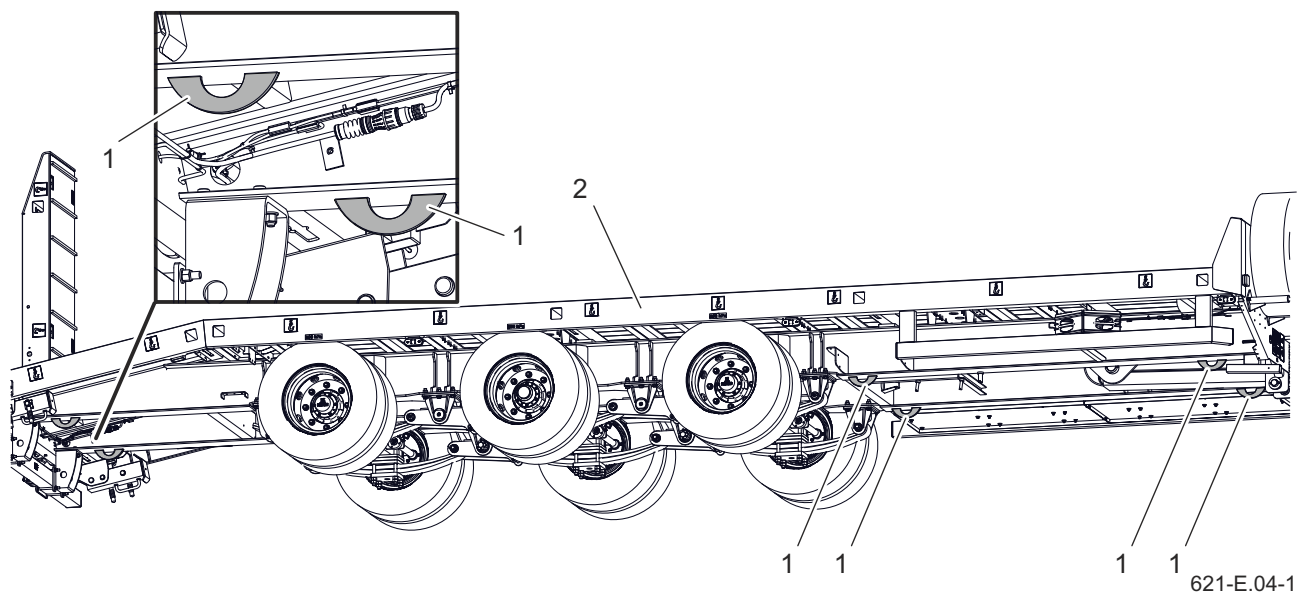

Figure 1.4 Attachment points on the trailer
 (1) transport lug (2) frame



ATTENTION

Do NOT secure lifting slings or any types of securing elements to hydraulic and electrical system components and fragile elements of the machine (e.g. shields, conduits)

stays, etc.) and the force necessary for their tensioning depends on a number of things, including weight of the trailer, the design of the transport vehicle, speed of travel and other conditions. A correctly secured trailer does not change its position with regard to the transport vehicle. The securing elements must be selected according to the guidelines of the Manufacturer of these elements. In case of doubt use a greater number of securing straps in order to immobilise the trailer. If necessary,

sharp edges of trailer should be protected at the same time protecting the securing straps from breaking during transport.

During reloading work, particular care should be taken not to damage parts of the machine's fittings or the lacquer coating. The tare weight of the trailer in condition ready for travel is given in table (3.1).

TRAILER TRANSPORTED BY THE USER

If a purchased trailer is transported by the user, the user must read the *Operator's Manual* of the trailer and adhere to the recommendations contained therein. Transport of the trailer by the user involves towing the trailer with own truck tractor to destination. During transport adjust travel

speed to the prevailing road conditions, speed.
but do not exceed the maximum design

E.3.6.621.05.1.EN

1.6 ENVIRONMENTAL HAZARDS

A hydraulic oil leak constitutes a direct threat to the natural environment owing to its limited biodegradability. While carrying out maintenance and repair work, which involves the risk of an oil leak, this work should take place on an oil resistant floor or surface. In the event of oil leaking into the environment, first of all contain the source of the leak, and then collect the leaked oil using available means. Remaining oil should be collected using sorbents, or by mixing the oil with sand, sawdust or other absorbent materials. The oil contaminations, once gathered up, should be kept in a sealed, marked, hydrocarbon resistant container, and then passed on to the appropriate oil waste recycling centre. The container should be kept away from heat sources, flammable materials and food.



DANGER

Used hydraulic oil or gathered remains mixed with absorbent material should be stored in a precisely marked container. Do not use food packaging for this purpose.

Oil which has been used up or is unsuitable for further use owing to loss of its properties should be stored in its original packaging in the conditions described above.



ATTENTION

Waste oil should only be taken to the appropriate facility dealing with the re-use of this type of waste. Do NOT throw or pour oil into sewerage or water tanks.

E.3.6.621.06.1.EN

1.7 WITHDRAWAL FROM USE

In the event of decision by the user to withdraw the machine from use, comply with the regulations in force in the given country concerning withdrawal from use and recycling of machines withdrawn from use.

Before proceeding to dismantle machine, oil shall be completely removed from hydraulic system.

When spare parts are changed, worn out or damaged parts should be taken to



DANGER

During dismantling, use the appropriate tools, equipment (overhead travelling crane, crane or hoist etc.) and use personal protection equipment, i.e. protective clothing, footwear, gloves and eye protection etc.

a collection point for recyclable raw materials. Used oil and also rubber and plastic elements should be taken to the appropriate facilities dealing with the recycling of this type of waste.

E.3.1.526.07.1.EN

SECTION 2

SAFETY ADVICE

2.1 BASIC SAFETY RULES

- The trailer must not be used for purposes other than those for which it is intended. Anyone who uses the machine in any other way than the way intended takes full responsibility for any consequences of this use. Use of the trailer for purposes other than those for which it is intended by the Manufacturer may invalidate the guarantee.
- Before using the trailer, the user must carefully read this Operator's Manual and the Warranty Book. During use all the recommendations laid down in the Operator's Manual and the Warranty Book should be observed.
- The trailer may only be used and operated by persons qualified to drive agricultural tractors with a trailer.
- The user is obliged to know the functions of all control elements of the machine. Do not use the machine without the knowledge of its functions.
- The user is obliged to acquaint himself with the design, operation and the principles of safe use of the trailer.
- Before using the trailer always check whether it is properly prepared for work, especially in terms of safety.
- If the information contained in the Operator's Manual is difficult to understand, contact a seller, who runs an authorised technical service on behalf of the Manufacturer, or contact the Manufacturer directly.
- Entering the trailer is only allowed when the machine is absolutely motionless. Stop the tractor, remove the key from the ignition and secure the tractor and trailer against rolling by placing chocks under the wheels. Immobilise tractor and trailer with parking brake. When entering the trailer load box, use platforms or ladders with proper height and load capacity. Do not climb the underrun protection devices and wheels to enter the trailer load box.
- Careless and improper use and operation of the trailer and also non-observance of the recommendations contained in this Operator's Manual endanger health and life of third persons and/or machine operators.
- The trailer may only be used when all safety guards and other protective elements are technically sound and correctly mounted.
- Pronar Sp. z o.o. warns about the

existence of residual risk, and for this reason the fundamental basis for using this trailer should be the application of safety rules. Follow the “Safety First” principle.

- The machine must not be used by persons who are not authorised and not able to operate it, in particular children and persons under the influence of alcohol, drugs or other abusive substances, etc.
- Any modification to the trailer frees Pronar from any responsibility for damage or detriment to health which may arise as a result.
- Warning and information labels must always be legible and clean. Missing or illegible labels must be replaced with new ones.
- When operating the trailer wear protective gloves and use the appropriate tools.
- Exercise due caution when using the trailer’s ramps. Do NOT stand behind the ramp when rising/lowering the ramp.
- Exercise due caution when using the winch.

F.3.6.621.01.1.EN

2.2 SAFETY WHEN HITCHING THE MACHINE

- Be especially careful when hitching the machine.
- When hitching, there must be nobody between the trailer and the tractor.
- Do NOT hitch the trailer to agricultural tractor, if the tractor does not meet the minimum requirements specified by the Manufacturer
- Before hitching the trailer, make certain that oil in external hydraulic system of the tractor is allowed to be mixed with hydraulic oil in the trailer.
- Before hitching the trailer check that both machines are in good technical condition.
- Use the proper tractor's hitch for hitching the trailer. After completed hitching of the machines check that the hitch is properly secured. The height of the trailer drawbar eye should be optimally adjusted to the height of the hitch. If necessary, read applicable sections in the tractor Operator's Manual.
- If the tractor is equipped with an automatic hitch, make certain that the hitching is completed.
- Hitching and unhitching the trailer may only take place when the machine is immobilised with the parking brake.
- When the trailer hitching is completed, raise the support and set it to transport position.
- While placing the support in transport position or rest position, do not place hand between moving elements of the support. Ensure that the support is properly locked with the use of an interlock.

F.3.6.621.02.1.EN

2.3 SAFETY RULES WHEN MAINTAINING HYDRAULIC SYSTEM AND PNEUMATIC SYSTEM

- When operating, the hydraulic and pneumatic systems are under high pressure.
- Regularly check the technical condition of the connections and the hydraulic and pneumatic conduits. Do NOT use the trailer with leaky system.
- In the event of malfunction of the hydraulic or pneumatic system, do not use the trailer until the malfunction is corrected.
- Repairs and replacements of hydraulic system components should be carried out by the appropriately qualified persons.
- When connecting the hydraulic conduits to the tractor, make sure that the hydraulic system of the tractor and that of the trailer are not under pressure. If necessary, reduce residual pressure in the system.
- In the event of injuries being caused by pressurised hydraulic oil, contact a doctor immediately. Hydraulic oil may find its way under the skin and cause infections. In the event of contact of oil with eyes, rinse eyes with a large quantity of water and if irritation occurs, consult a doctor. In the event of contact of oil with skin wash the area of contact with water and soap. Do NOT apply organic solvents (petrol, kerosene).
- Use the hydraulic oil recommended by the Manufacturer.
- Used oil should be disposed of in a professional manner. Used oil or oil which has lost its properties should be stored in original containers or replacement containers resistant to action of hydrocarbons. Replacement containers must be clearly marked and appropriately stored.
- Do not store hydraulic oil in packaging designed for storing food or foodstuffs.
- Rubber hydraulic conduits must be replaced every 4 years regardless of their technical condition.

F.3.6.209.03.6.EN

2.4 SAFE MAINTENANCE PRINCIPLES

- During the warranty period, any repairs may only be made by the Warranty Service authorised by the Manufacturer. After the expiry of the warranty period it is recommended that possible repairs to the trailer be performed by specialised workshops.
- In the event of any fault or damage, do not use the trailer until the fault has been fixed.
- While performing maintenance work, use proper, close-fitting protective clothing, gloves, protective shoes, protective goggles and appropriate tools.
- Any modification to the trailer frees the trailer Manufacturer from any responsibility for damage or detriment to health which may arise as a result.
- Regularly check the condition of nut and bolt connections, in particular connections of drawbar eye with drawbar and wheel nuts. The control of nut tightening is described in section *Maintenance*.
- Service inspections should be carried out according to the schedule in this Operator's Manual.
- Before beginning repair work on hydraulic or pneumatic systems reduce oil or air pressure completely.
- Servicing and repair work should be carried out in line with the general principles of workplace health and safety. In the event of injury, the wound must be immediately rinsed and disinfected. In the event of more serious injuries, seek a doctor's advice.
- Repair, maintenance and cleaning work should be carried out with the tractor engine turned off and the ignition key removed. Tractor and trailer must be immobilized with parking brake and chocks should be placed under the trailer wheels. Close the tractor cab and ensure that unauthorised persons do not have access to the cab.
- During maintenance or repair work, the trailer may be unhitched from tractor, but it must be secured with chocks and parking brake.
- Should it be necessary to change individual parts, use only those parts indicated by the Manufacturer. Non-adherence to these requirements may put the user and

other people's health and life at risk, and also damage the machine and invalidate the guarantee.

- Before welding or electrical work, the trailer should be disconnected from the power supply. The paint coating should be cleaned. Burning paint fumes are poisonous for people and animals. Welding work should be carried out in a well lit and well ventilated space.
- During welding work, pay attention to flammable or fusible elements (parts of the pneumatic, electric and hydraulic systems, plastic parts). If there is a risk that they will catch fire or be damaged, they should be removed or covered with non-flammable material before commencing welding work. Before beginning work, prepare a CO₂ or foam extinguisher.
- In the event of work requiring the trailer to be raised, use properly certified hydraulic or mechanical lifts for this purpose. After lifting the machine, stable and durable supports must also be used. Work must not be carried out under a trailer, which has only been raised with a lift or jack.
- The trailer must not be supported using fragile elements (bricks or concrete blocks).
- The lifting jack should have sufficient lifting capacity and should be technically reliable. The lifting jack must be positioned on a level and hard surface so as to prevent sinking into the ground or relocating the jack during lifting. If necessary, use proper backing plates in order to reduce unit pressure of the jack's base on the ground and prevent its sinking into the ground.
- After completing work associated with lubrication, remove excess oil or grease. The trailer should be kept clean and tidy.
- The user must not repair by himself the components of the hydraulic or pneumatic system i.e. control valves, modules, cylinders and regulators. In the event of damage to these elements, repair should be entrusted to an authorised service point or elements should be replaced with new ones.
- Do NOT install additional appliances or fittings not according to the specifications defined by the Manufacturer.
- The trailer may only be towed when axles and wheels, lighting system

- and brakes are reliable.
- Do NOT make repairs to drawbar and drawbar eye (straightening,

pad welding or welding). Damaged drawbar or drawbar eye must be replaced with a new one.

F.3.1.526.04.1.EN

2.5 SAFE DRIVING

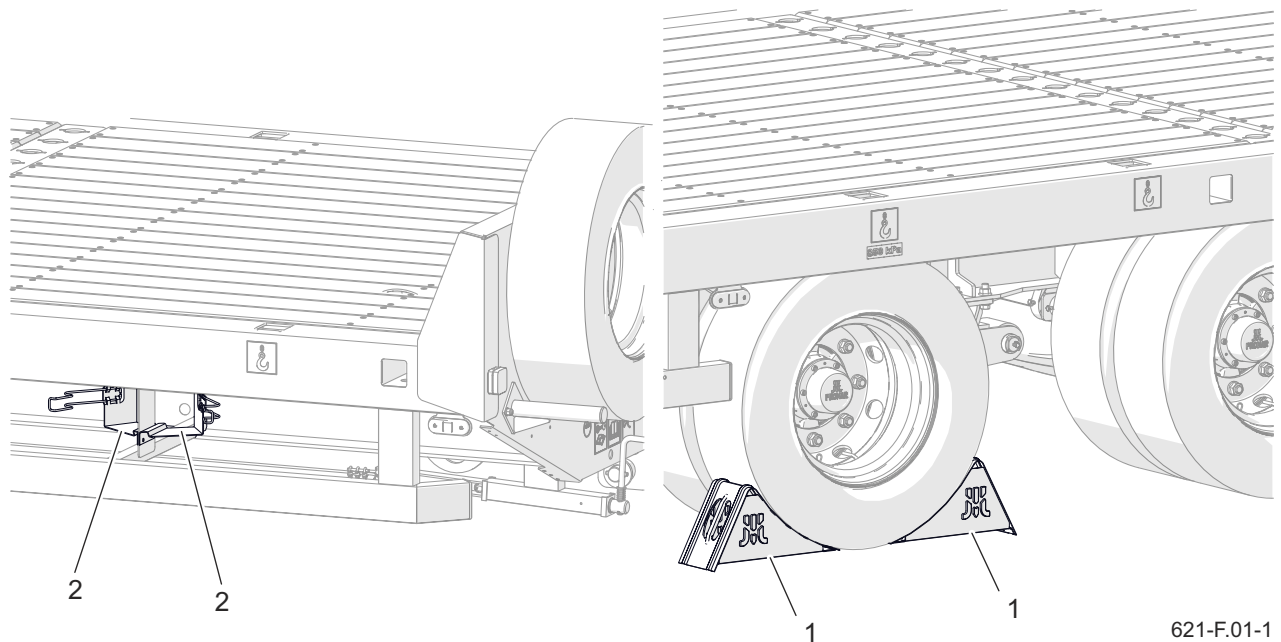

Figure 2.1 Method of placing chocks
 (1) chocks (2) wheel chock handle

- During travel on public roads comply with the road traffic regulations and transport regulations in force in a given country, in which the trailer is used.
- Adjust travel speed to the existing road conditions and other limitations arising from road traffic regulations. Excessive speed may cause loss of control over the tractor-trailer combination and damage to the trailer and/or tractor and may limit braking efficiency of the tractor-trailer combination
- The machine must NOT be left unsecured. The trailer unhitched from the

tractor must be secured against rolling away by means of parking brake and wheel chocks placed under the wheel. The wheel chocks should be placed under one rear axle, in front and behind the wheel - Figure (2.1).

- Before driving off make certain that the machine is correctly hitched to the tractor.
- Before using the trailer always check its technical condition, especially in terms of safety. In particular, check the technical condition of the hitch system, the axle system, the brake system, indicator lights and the connective elements of the hydraulic and

electrical systems.

- Before driving on public roads, place the triangular slow-moving vehicle warning sign on the left ramp - figure (2.2).

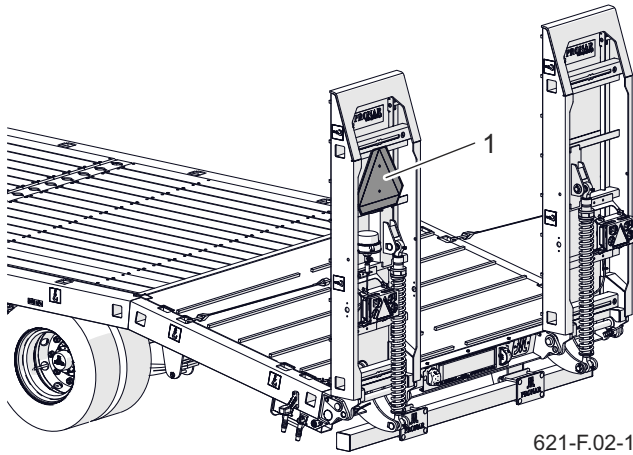

Figure 2.2 Mounting place for the slow-moving vehicle warning sign
(1) warning sign

- While driving on public roads, the trailer and the tractor must be fitted with a certified or authorised reflective warning triangle.
- Before moving off, make sure that the parking brake is released.
- The trailer's ramps must be folded. Travelling with ramps which are unfolded and not secured is prohibited. Secure the ramps using securing straps with a tensioner.
- Travelling with the trailer's support leg in parking position is prohibited. Before moving off make sure that the support leg is properly placed in transport position and secured.
- The trailer is designed to operate on slopes up to 8°. Driving trailer across ground with steeper slopes may cause the trailer to tip over as a result of loss of stability. Prolonged driving across steep ground may lead to loss of braking efficiency.
- The arrangement of the load may not cause an overload on the axle or hitch system of the trailer or tractor.
- Reckless driving and excessive speed are the most frequent causes of accidents.
- A load protruding beyond the edge of the trailer should be marked according to the road traffic regulations. Use the marking signs for oversize loads and yellow warning light (option) if they are included in the trailer's equipment.
- Do NOT transport loads forbidden by the Manufacturer.
- Oversize load may be transported on public roads only if a travel permit is obtained from a competent office.
- If possible avoid travelling on uneven terrain and unexpected turning.
- Do NOT attempt to enter the trailer load box while travelling.
- Exceeding the carrying capacity may lead to damage to the machine, loss of stability while driving and danger

while driving.

- The brake system is adjusted to the gross weight of the trailer, exceeding the weight limit causes drastic reduction of basic braking effectiveness.
- During reversing (especially in limited visibility conditions) one should use

the assistance of another person. During manoeuvring the assistant must stay at a safe distance from the danger zone and be visible all the time to the tractor driver.

- Take particular care while driving near overhead electrical power lines.

F.3.6.621.05.1.EN

2.6 LOADING AND UNLOADING

- Loading and unloading work should be carried out by persons experienced in this type of work.
- The trailer is not intended for transporting people, animals or hazardous materials.
- The load must not protrude further out than the load platform's front wall. The load must be arranged in such a way that it does not threaten the stability of the trailer and does not hinder driving.
- Load must be protected against moving by means of belts, chains, straps or other certified securing measures with a tensioning mechanism.
- The arrangement of the load must not cause overloading the axle system.
- Incorrect load distribution and overloading the machine may cause the trailer to tip over or cause damage to its components.
- Do NOT climb on the load platform during loading. Secure the load only when the machine rests on the load platform planks.
- Unloading and loading of trailer may only take place when the machine is positioned on level and hard surface and connected to tractor. Tractor and trailer must be placed to drive forwards.
- Ensure that there are no bystanders in the unloading/loading zone.
- Be especially careful when opening or closing the ramps because there is a risk of crushing fingers. Unfolded ramps must adhere to a level surface and must be at the same height.
- Loading equipment may work on the load platform only if the total weight of the loading equipment and the load does not exceed the maximum carrying capacity of the trailer.
- Do not exceed the permissible load weight when using the hydraulic winch.
- When using the trailer's ramps during loading and unloading, use the rear load platform supports. Be especially careful when using the supports because there is a risk of crushing fingers. Use protective gloves.

F.3.6.209.06.1.EN

2.7 TYRES

- When working on the tyres, chocks or other objects without sharp edges should be placed under the wheels of the trailer to prevent it from rolling. Wheels can be taken off the trailer axle only when the trailer is not loaded.
- Repair work on the wheels or tyres should be carried out by persons trained and entitled to do so. This work should be carried out using appropriate tools.
- Check if the wheel nuts are properly tightened, according to the specified frequency.
- Avoid potholes, sudden manoeuvres or high speeds when turning.
- Check the tyre pressure regularly.

Air pressure in tyres should be also checked during the whole day of intensive work. Please note that higher tyre temperatures could raise air pressure in tyres. At high temperatures and pressure, reduce load or speed. Do not release air from warm tyres to adjust the pressure or the tyres will be underinflated when temperatures return to normal.

- Protect tyre valves using suitable caps to avoid soiling.
- Be especially careful when taking the spare wheel out because of the risk of crushing hands or feet. It is strictly forbidden to be under the spare wheel when lowering or raising it.

F.3.6.209.07.1.EN

2.8 RESIDUAL RISK

Pronar Sp. z o. o. in Narew has made every effort to eliminate the risk of accidents. There is, however, a certain residual risk, which could lead to an accident, and this is connected mainly with the actions described below:

- using the trailer for purposes other than those for which it is intended,
- being between the tractor and the trailer while the engine is running and when the machine is being attached,
- being on the machine while the engine is running,
- operating the machine with removed or faulty safety guards,
- not maintaining a safe distance from the danger zone or being within the zones while the machine is operating,
- operation of the machine by unauthorised persons or persons under the influence of alcohol or other intoxicating substances,
- making modifications to the machine without the consent of the Manufacturer,
- cleaning, maintenance and technical

checks of the trailer,

- presence of persons, animals or obstacles in areas invisible from the operator's position.

The residual risk can be kept to a minimum by following the recommendations below:

- operate the machine in prudent and unhurried manner,
- sensibly adhere to the remarks and recommendations contained in the OPERATOR'S MANUAL,
- carry out repairs and maintenance work in line with operating safety rules,
- repair and maintenance work should be carried out by persons trained to do so,
- use close fitting protective clothing,
- ensure unauthorised persons have no access to the machine, especially children.
- maintain a safe distance from prohibited or dangerous places
- do not climb on the machine when it is operating

F.3.6.621.08.1.EN

2.9 INFORMATION AND WARNING DECALS

The machine is labelled with the information and warning decals mentioned in table 2.1. Throughout the time it is in use, the user of the machine is obliged to take care that notices and warning and information symbols located on the machine are clear and legible. In the event of their destruction, they must be replaced with new ones. Safety decals can be purchased

from the Manufacturer of the machine or your PRONAR dealer. New assemblies, changed during repair, must be labelled once again with the appropriate safety signs. During machine cleaning do not use solvents which may damage the coating of information label stickers and do not subject them to strong water jets.

Table 2.1 Information and warning decals

Item	Description	Part number
1	Permissible hitching system loading.	103N-00000002
2	Regularly lubricate the trailer according to the lubrication schedule.	104N-00000004
3	Regularly check if the nuts and bolts fixing the wheels and other components are properly tightened.	104N-00000006
4	Marking of mounting points for belts, ropes, chains or other devices for securing load on the platform.	123N-00000013
5	Manufacturer's decal.	187N-00000016
6	Air pressure in the tyres ⁽¹⁾ - standard tyres.	208N-00000006
7	Hydraulic winch operation information decal.	208N-00050004
8	Machine type label.	621N-65000001
9	Caution! Before starting work, carefully read the Operator's Manual.	70N-00000004
10	Before repairs, maintenance activities or other servicing activities, turn off engine and remove key from ignition	70N-00000005

⁽¹⁾ Air pressure in tyres depends on tyres used.

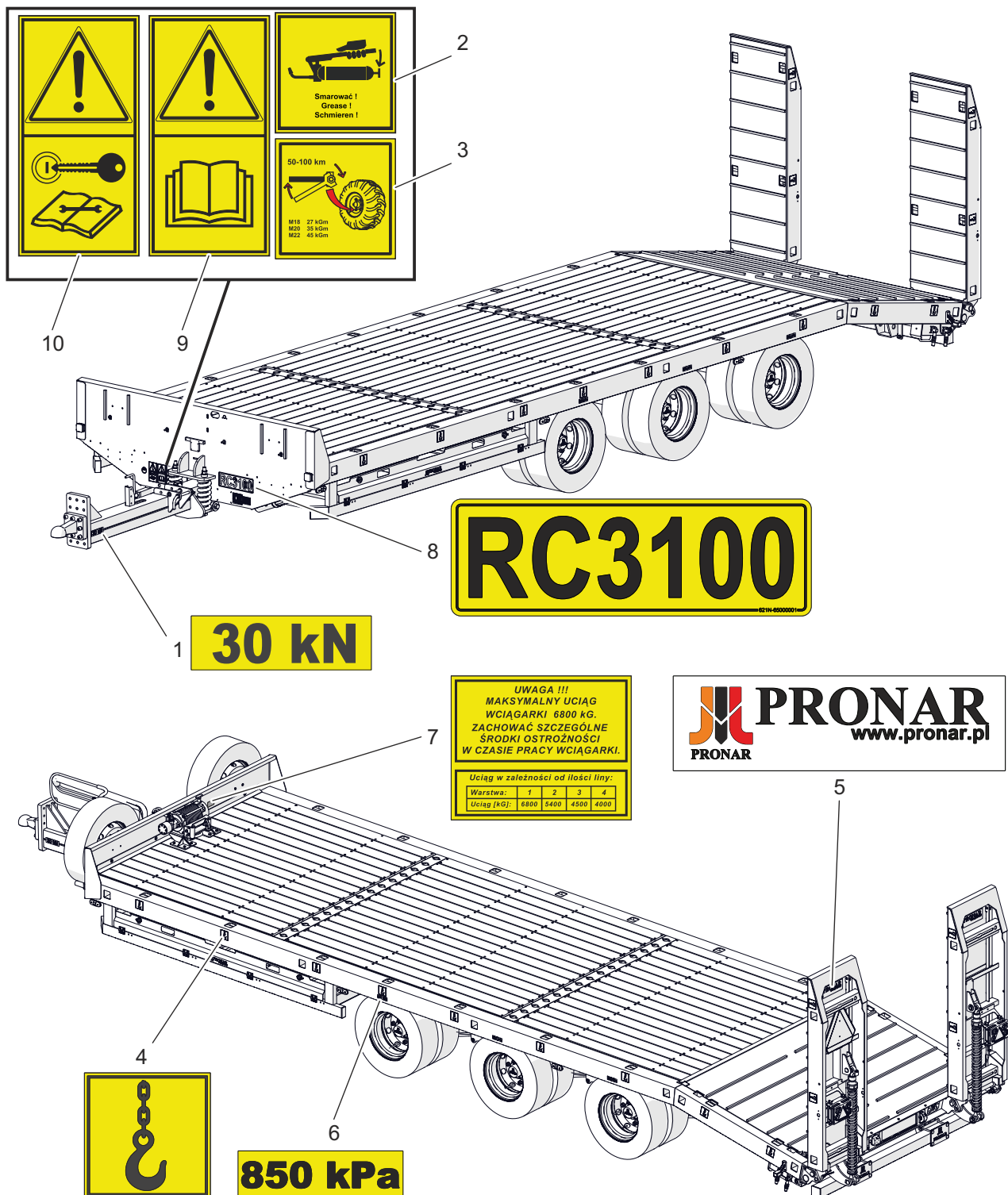

621-F.03-1

Figure 2.3 Locations of information and warning decals

SECTION 3

DESIGN AND OPERATION

3.1 TECHNICAL SPECIFICATION

Table 3.1 Basic technical specification

Contents	Unit	RC3100
Dimensions		
Length	mm	10 410
Width	mm	2 550
Height	mm	2 500
Load box dimensions		
Total load platform length	mm	8 340
Length of straight section of load platform	mm	6 800
Ramps length	mm	1 900
Floor width	mm	2 540
Floor width with extensions	mm	3 000
Technical specification		
Carrying capacity	kg	18,540
Maximum gross weight (EU)	kg	24,000
Tare weight	kg	5,460
Height of platform from the ground	mm	930
Load surface		
straight section (+extensions)	m ²	17.3 (+3)
total (+extensions)	m ²	21.3 (+3.7)
Other information		
Electrical system voltage	V	12
Number of axles:	pc.	3
Maximum axle load	kg	8 000
Maximum hitch load	kg	3 000
Maximum design speed	km/h	40 or 60
Tyre size (standard):	-	215/75 R17.5
Minimum tractor power demand	hp/kW	104 / 76.4
Fixing lugs (with ramps)	pc.	19 (23)

Information on tyres is provided in section 7 "Tyre system".

G.3.6.621.01.1.EN

3.2 GENERAL DESIGN

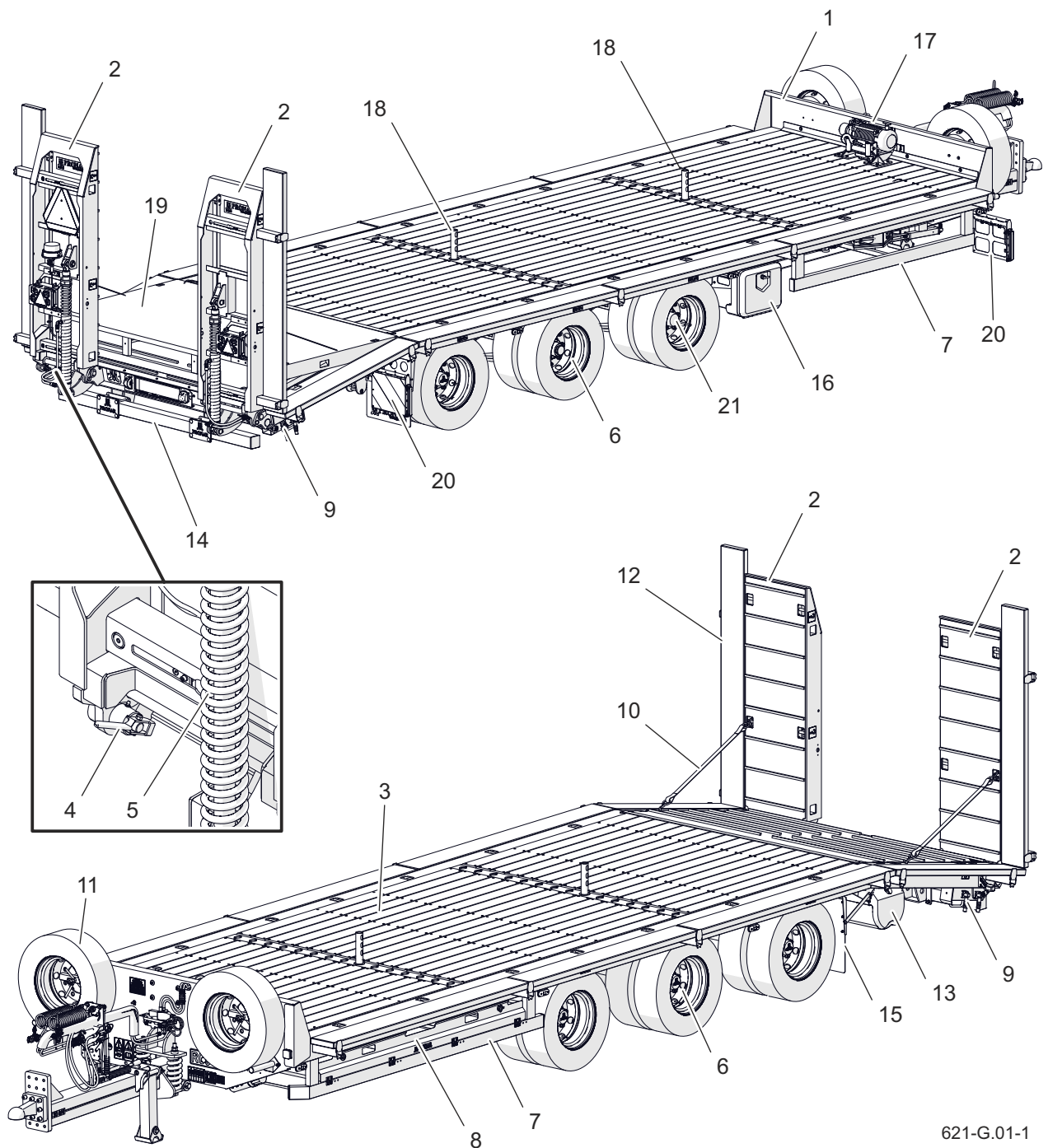

621-G.01-1

Figure 3.1 Trailer construction

- | | | |
|---------------------------------|--------------------------------------|-------------------------|
| (1) frame | (2) ramps | (3) floor planks |
| (4) spring catch | (5) spring | (6) tridem axle system |
| (7) under-run protective device | (8) plank holder | (9) rear support leg |
| (10) safety strap | (11) spare wheel | (12) platform extension |
| (13) water tank | (14) rear fender | (15) mud flap |
| (16) toolbox | (17) winch | (18) limiter |
| (19) ramp floor insert | (20) marking sign for oversize loads | (21) hubodometer |

Design of the trailer is shown in figures (3.1) and (3.2).

The trailer frame (1) is a structure welded from steel sections.

Wheels and suspension system (6) is connected with the frame using bolts. The system consists of three axles in tridem system with parabolic leaf springs connected with rocker arms. Axles are made from square bars terminated with pins, on which wheel hubs are mounted on cone bearings. Brake drums with shoe brakes are activated by mechanical cam expanders, which are operated by cylinders bolted to axle brackets.

In the rear of the trailer there are ramps

(2) equipped with springs (5). The springs assist in lowering and raising the ramps. In the transport position the ramps are secured using locking pins (4) and transport straps (10). Lighting elements and reflective lights are attached to the bottom side of the ramps.

The load platform floor is made of coniferous wood or oak wood profiled planks (3). Load placed on the platform is secured with belts, ropes or chains, which are attached to fixing lugs located along the whole platform, on both sides of the trailer. The fixing lugs are marked with information decals (4) – table (2.1). On the front side, the load platform is limited by

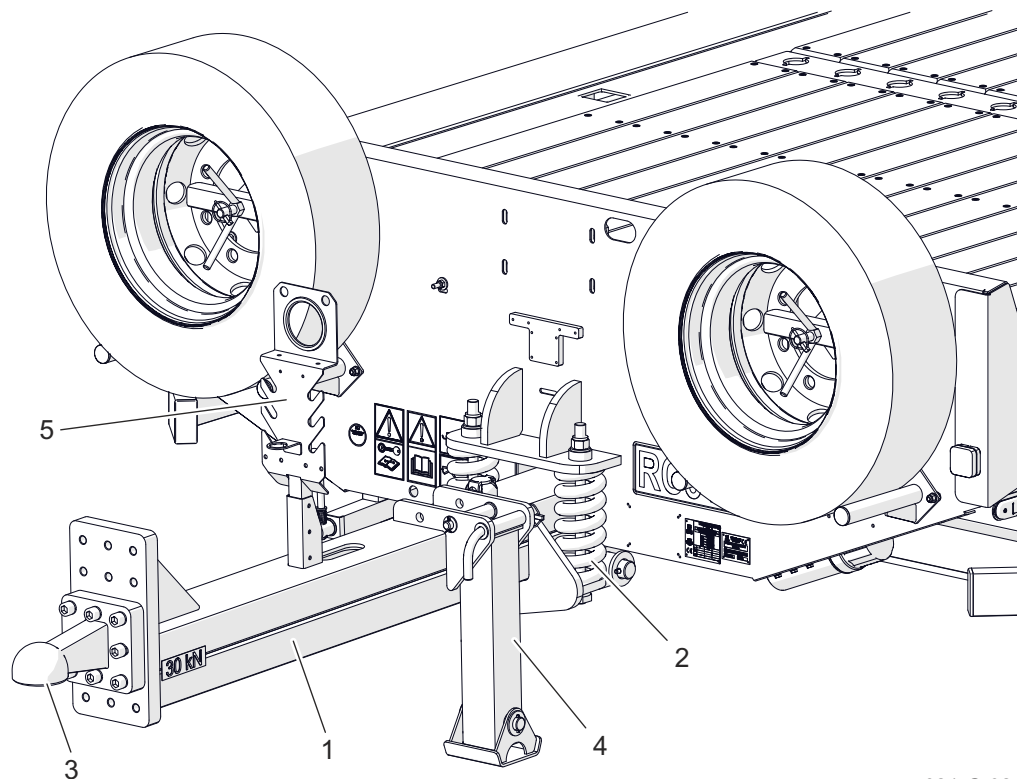

621-G.02-1

Figure 3.2 Trailer construction

(1) drawbar

(2) spring

(3) drawbar eye

(4) parking stand

(5) bracket for conduit connectors

wall to which spare wheels (11) (optional equipment) are attached. Optional winch (17) with hydraulic drive system is installed behind the front wall - figure (3.1).

On the left side, between the under-run protective device (7) and floor surface, there is a holder (8) for storing planks which are used for widening the load platform (12) – figure (3.1).

In the front part of the trailer, there is a drawbar (1) with shock absorbing springs (2) – figure (3.2). Drawbar hitching eye (3) is bolted to the drawbar faceplate.

Depending on configuration, K80 ball drawbar, fixed drawbar with a 50mm eye, fixed drawbar with a 40mm eye or rotating drawbar with a 50mm eye can be used.

On the left side of the drawbar, there is a parking stand (4) (mechanical or hydraulic stand). On the upper profile of the drawbar there is a bracket for conduit connectors (5).

The trailer can be additionally equipped with a hubodometer (21) mounted on the middle or first axle, on the right side.

G.3.6.621.02.1.EN

3.3 MAIN BRAKE

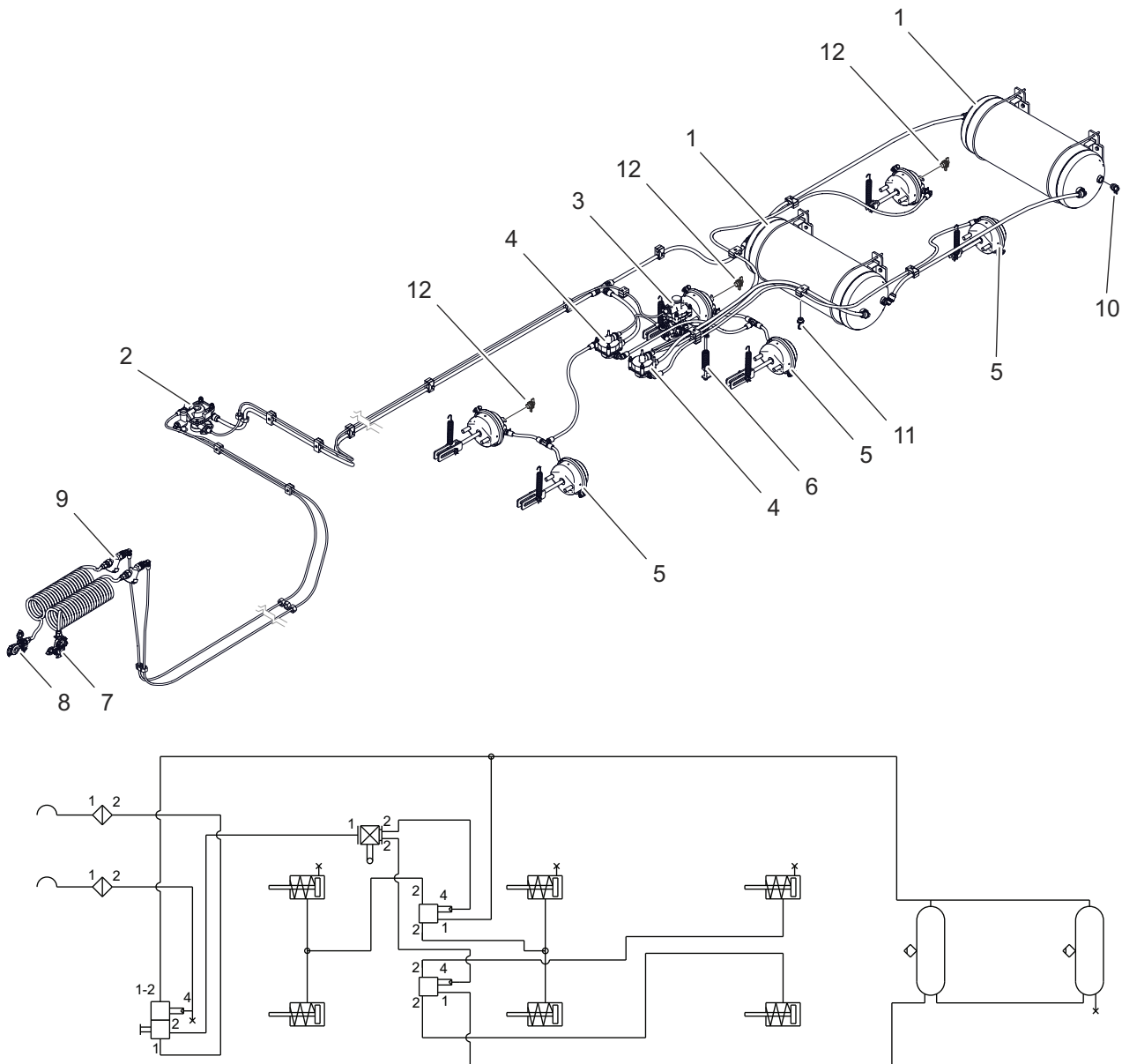

621-G.03-1

Figure 3.3 Diagram of the pneumatic braking system with ALB automatic regulator

- | | | |
|----------------------------------|---------------------------------|----------------------------------|
| (1) air tank | (2) control valve | (3) ALB braking force regulator |
| (4) relay valve | (5) pneumatic cylinder | (6) slider of ALB regulator |
| (7) supply connection (red) | (8) control connection (yellow) | (9) air filter |
| (10) air tank control connection | (11) drain valve | (12) cylinder control connection |

The trailer is equipped with double conduit pneumatic brake system with automatic braking force regulator.

The main brake is activated from the tractor driver's cab by pressing on the

brake pedal. The task of the control valve (2) is to activate the trailer's brakes when the brake pedal is depressed in the tractor.

Furthermore, in case of an inadvertent disconnection of the conduit between the

trailer and the tractor, the control valve will automatically activate the trailer's brakes. Valve used in the system is equipped with a circuit causing the brakes to be applied when trailer is disconnected from the tractor. When compressed air conduit is connected to the tractor, the device automatically applying the brakes now changes its position to allow normal brake operation.

Pneumatic brake cylinders used in the systems are mounted on specially designed brackets welded to the wheel axles. In the pneumatic cylinders, air supplied to cylinder exerts pressure on membrane which in turn moves cylinder piston and rotates to axle expander lever. Return of cylinder to neutral position is assisted by draw back springs.

Relay valves (4) are designed to increase the speed of air transmission to cylinders during braking. Automatic braking force regulator (3) adapts braking pressure depending on the trailer load. During normal work it does not require service.

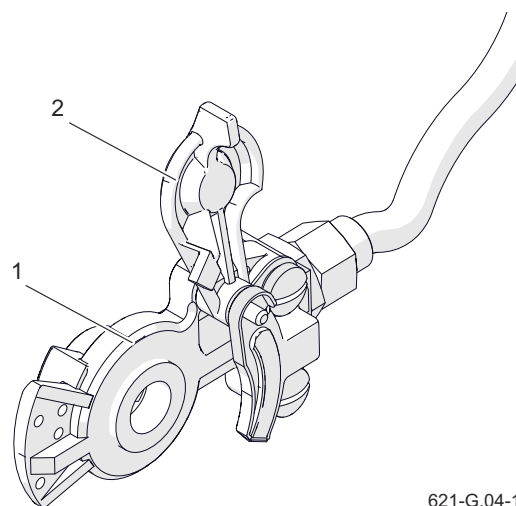

621-G.04-1

Figure 3.4 Pneumatic connection
(1) connection body
(2) connection cover

PNEUMATIC CONNECTIONS

Pneumatic connections are equipped with covers (2), that protect the connections against contamination and entrance of dirt into the system. They are made from coloured plastic (red connection – supply air; yellow connection - control air). The connections are made according to recommendations of DIN ISO 1728 standard. Thanks to this, the connections cannot be incorrectly connected to the agricultural tractor's sockets. After unhitching the trailer, place the pneumatic connections in the specifically prepared sockets, located on the drawbar.

G.3.6.621.03.1.EN

3.4 PARKING BRAKE

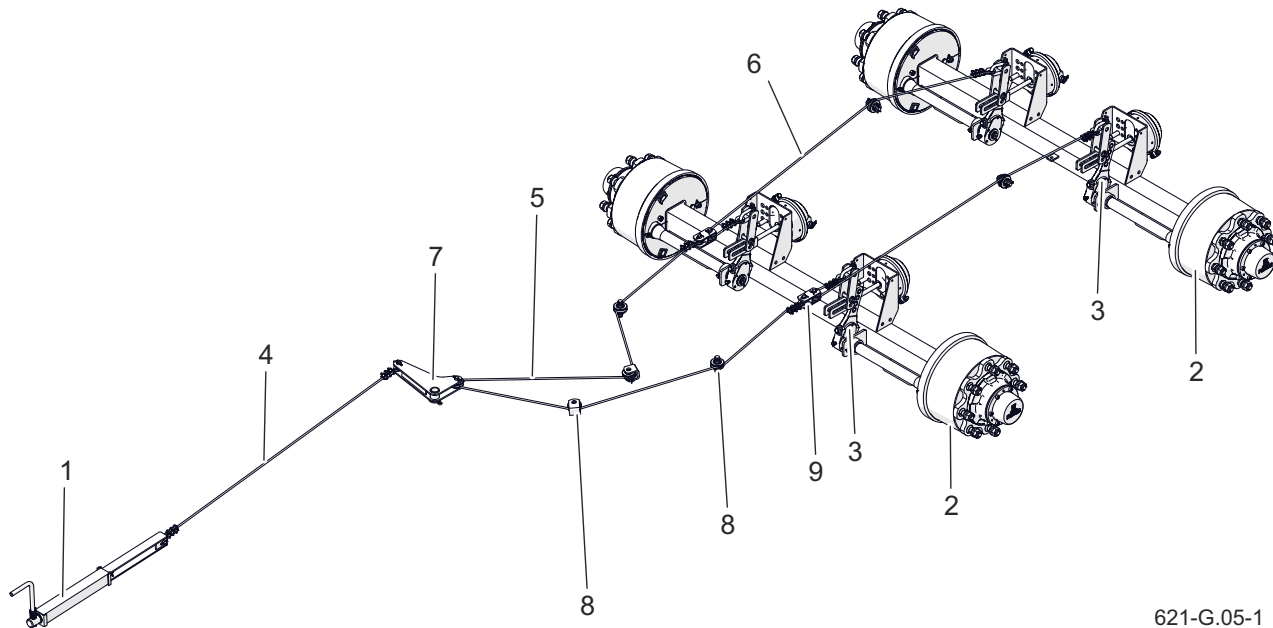

Figure 3.5 Parking brake design

(1) crank mechanism

(4) steel cable I

(7) lever

(2) wheel axle

(5) steel cable II

(8) guiding roller

(3) expander lever

(6) steel cable III

(9) brake pulley block

The parking brake is used for immobilising the trailer while parking. The brake crank mechanism (1) is attached to the right longitudinal member of the lower frame.

Expander levers (3) of the first axle and the second axle (2) are connected to lever (7), through brake pulley block (9), by means of cables (5) and (6). The cables are guided in rollers (8).

Lever (7) is connected to the brake crank mechanism (1) by means of steel cable I (4).

Tensioning the cable (4) (by turning the mechanism crank clockwise) causes deflection of lever (7) and tension of cable II (5) causing a deflection of expander arms (3), which immobilize the trailer by parting the brake shoes.

G.3.6.621.04.1.EN

3.5 HYDRAULIC SYSTEM OF THE RAMPS

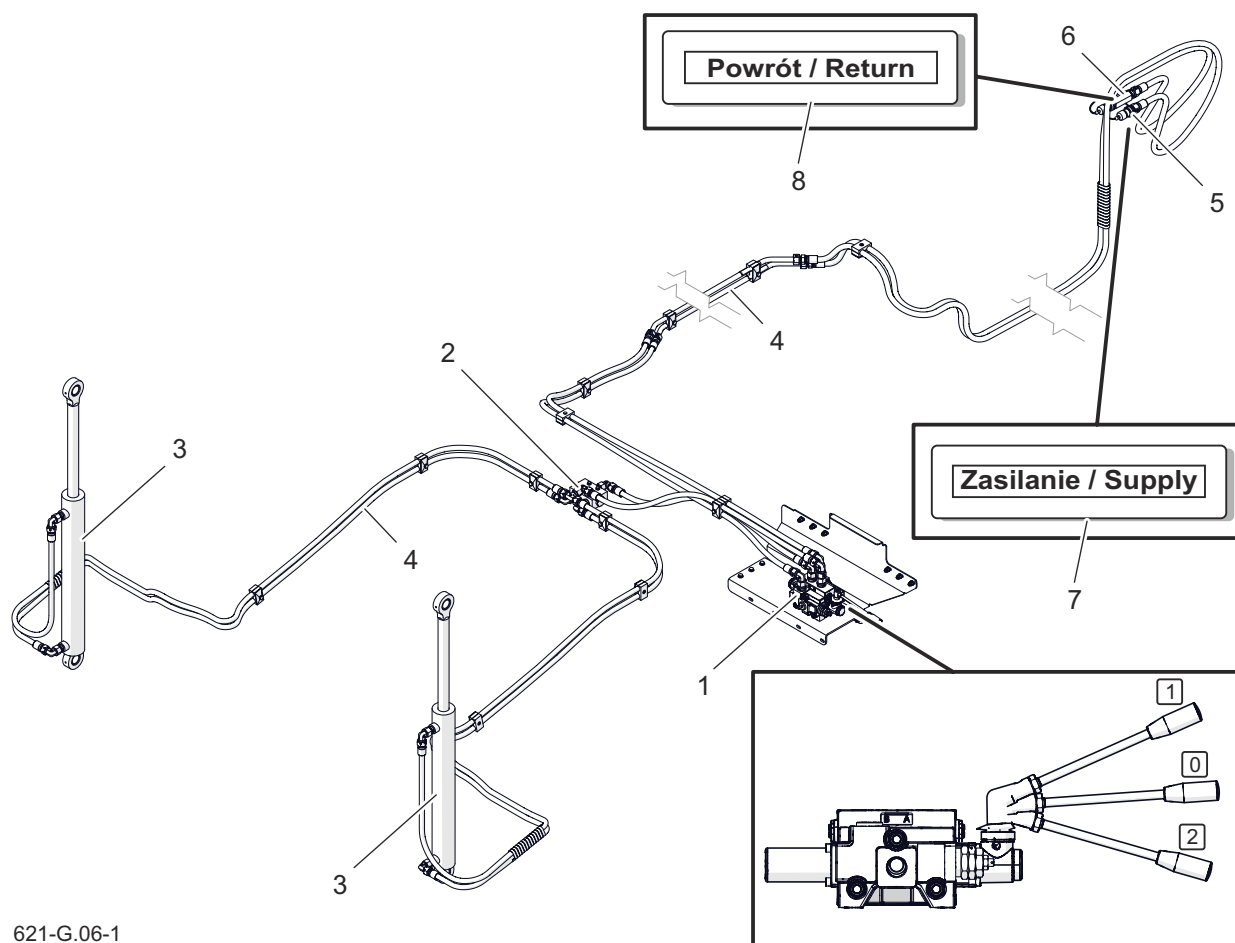

621-G.06-1

Figure 3.6 Arrangement of components of the ramps' hydraulic system

- | | | |
|--------------------------------|--------------------------------|-------------------------|
| (1) hydraulic divider | (2) flow divider | (3) hydraulic cylinder |
| (4) hydraulic conduits | (5) connection (supply) | (6) connection (return) |
| (7) information decal (supply) | (8) information decal (return) | |

Design of the hydraulic system for folding and unfolding the ramps is shown in figure (3.6) and on diagram (3.7).

The ramps are controlled (raised and lowered) by means of double-acting cylinders (3) through a single-section hydraulic distributor (1) located in the rear part of the frame, on the right side of the trailer. The system is supplied from the external hydraulic system of the tractor. To ensure correct connection, the supply



ATTENTION

Before unfolding the ramps, first loosen and then remove the transport straps.
Towing the trailer without installed and properly tightened interlocks is prohibited.

conduit and the return conduit are marked with information decals (7) and (8). The return conduit is equipped with a check valve ensuring oil flow in one direction only.

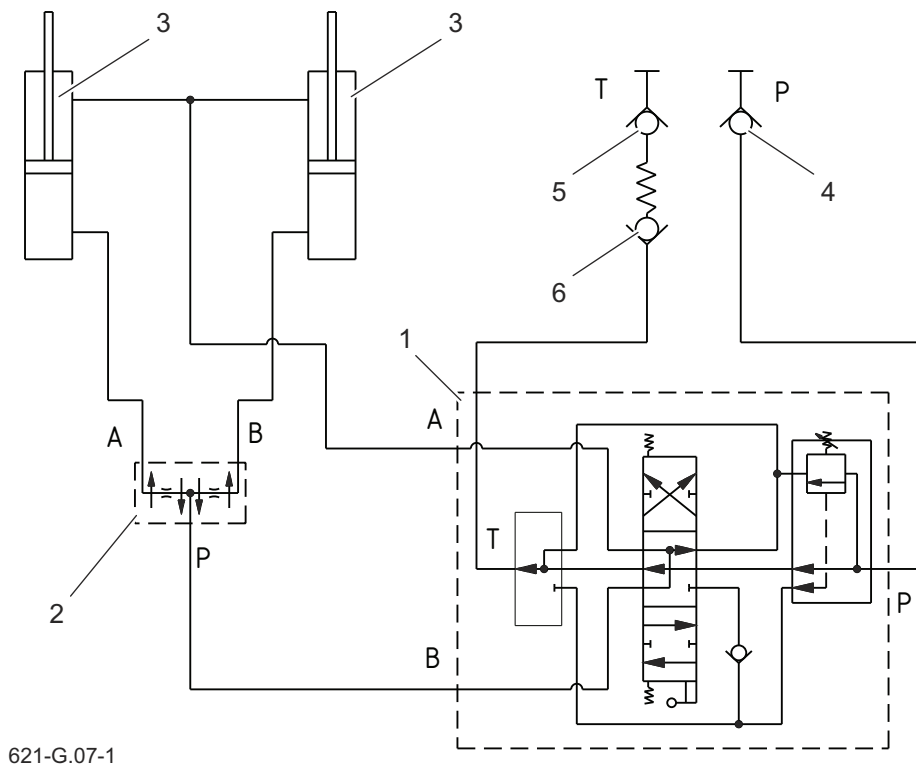

Figure 3.7 Diagram of the ramps' hydraulic system

(1) hydraulic divider

(2) flow divider

(3) hydraulic cylinder

(4) supply

(5) return

(6) check valve

Working positions of hydraulic distributor:

- (0) Neutral position
- (1) Rising the ramps
- (2) Lowering the ramps

G.3.6.621.05.1.EN

3.6 HYDRAULIC SUPPORT SYSTEM

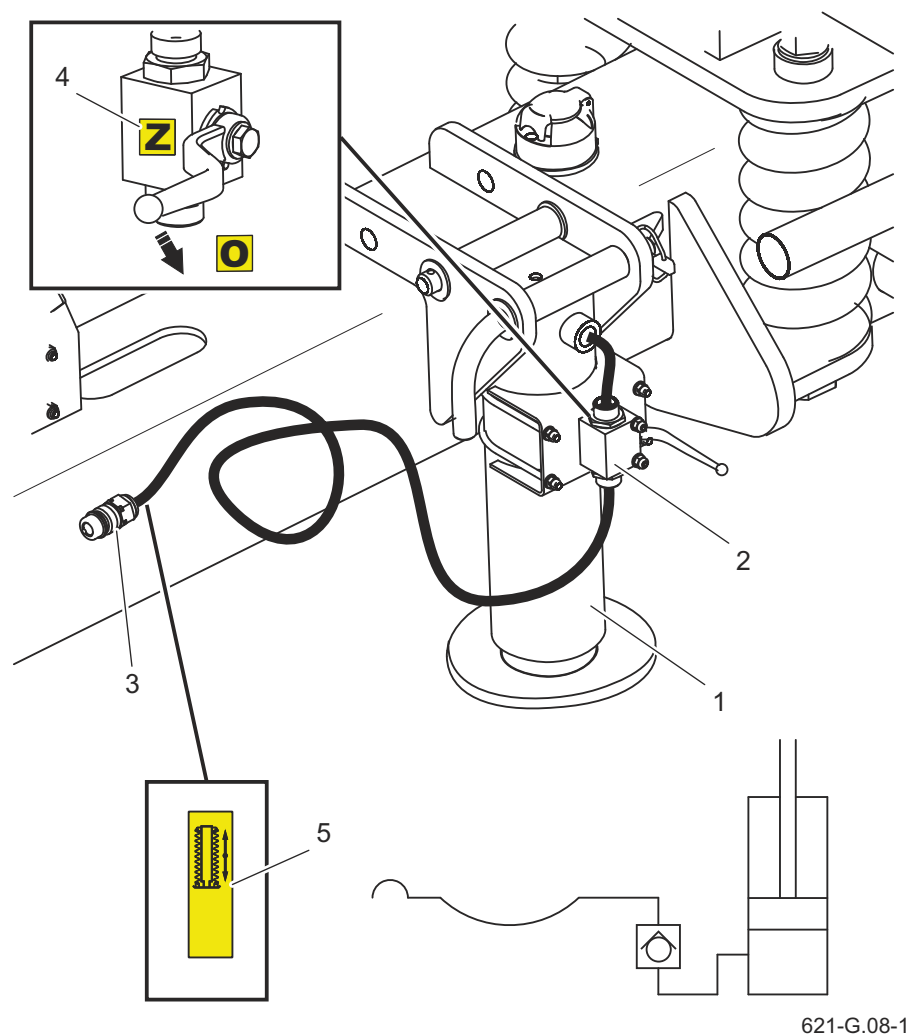

Figure 3.8 Design and diagram of the support hydraulic system

(1) straight hydraulic support

(2) cut-off valve

(3) hydraulic connection

(4) information decal (closed / open) (5) information decal

Design of the control system for the hydraulic support is shown in figure (3.8). The hydraulic system is equipped with a support with a single acting cylinder. The support foot return is accomplished by the tensioning springs located inside the support body. Supply conduit is marked

with information decal (5). The supply of hydraulic oil to the support is possible only when cut-off valve (2) is set to „O” position (open). When towing the trailer, the support must be folded to transport position and secured with a cotter pin. The cut-off valve must be set to „Z” position (closed).

G.3.6.621.06.1.EN

3.7 HYDRAULIC SYSTEM OF THE WINCH

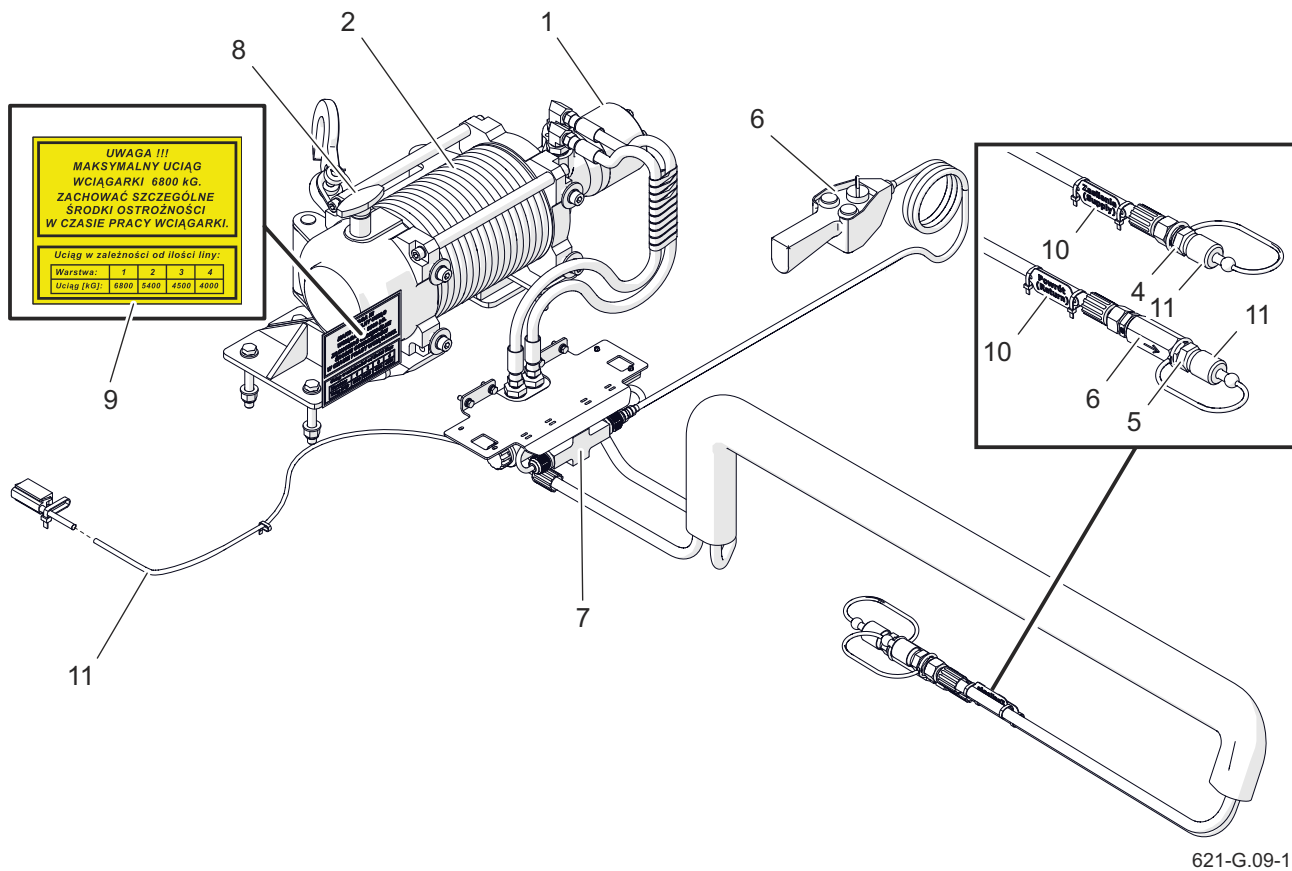

Figure 3.9 Hydraulic winch design

- | | | |
|---------------------|---------------------|--------------------|
| (1) hydraulic motor | (2) drum | (3) power lead |
| (4) return conduit | (5) check valve | (6) remote control |
| (7) solenoid valve | (8) releasing lever | (9) conduit label |
| (10) warning decal | (11) wiring harness | |

Depending on the needs, the trailer can be equipped with a hydraulic winch with a maximum pulling force of 6800 [kG] or 8000 [kG].

The hydraulic winch system design is shown in figure (3.9). The subassembly is mounted on the load platform planks behind the chassis front wall. The winch is designed for loading damaged machines and machines without driving system.

The machines pulled using the winch must have axles and wheels. Hydraulic motor (1) connected with the winch drum (2) is supplied from the external hydraulic system of the tractor. Oil is pumped from the tractor's hydraulic system to the winch hydraulic system through hydraulic conduits (3) and (4) terminated with hydraulic conduit connectors secured with red plugs (11). Conduits are marked with decals

(9). The return conduit is equipped with a check valve (5) ensuring oil flow in one direction only.

Steel rope ended with a hook is wound around the drum (2). The steel rope is routed between vertical and horizontal direction rollers. The winch is controlled by means of a remote control (6), which controls the solenoid valve (7). On the

right side of the drum there is a lever (8), whose task is to disconnect the drum drive in order to unwind the rope without the use of the hydraulic motor.

On the front wall of the trailer chassis there is a warning sticker (10) specifying the winch pulling force depending on the number of layers of rope wound on the drum.

G.3.6.621.07.1.EN

3.8 ELECTRICAL LIGHTING SYSTEM

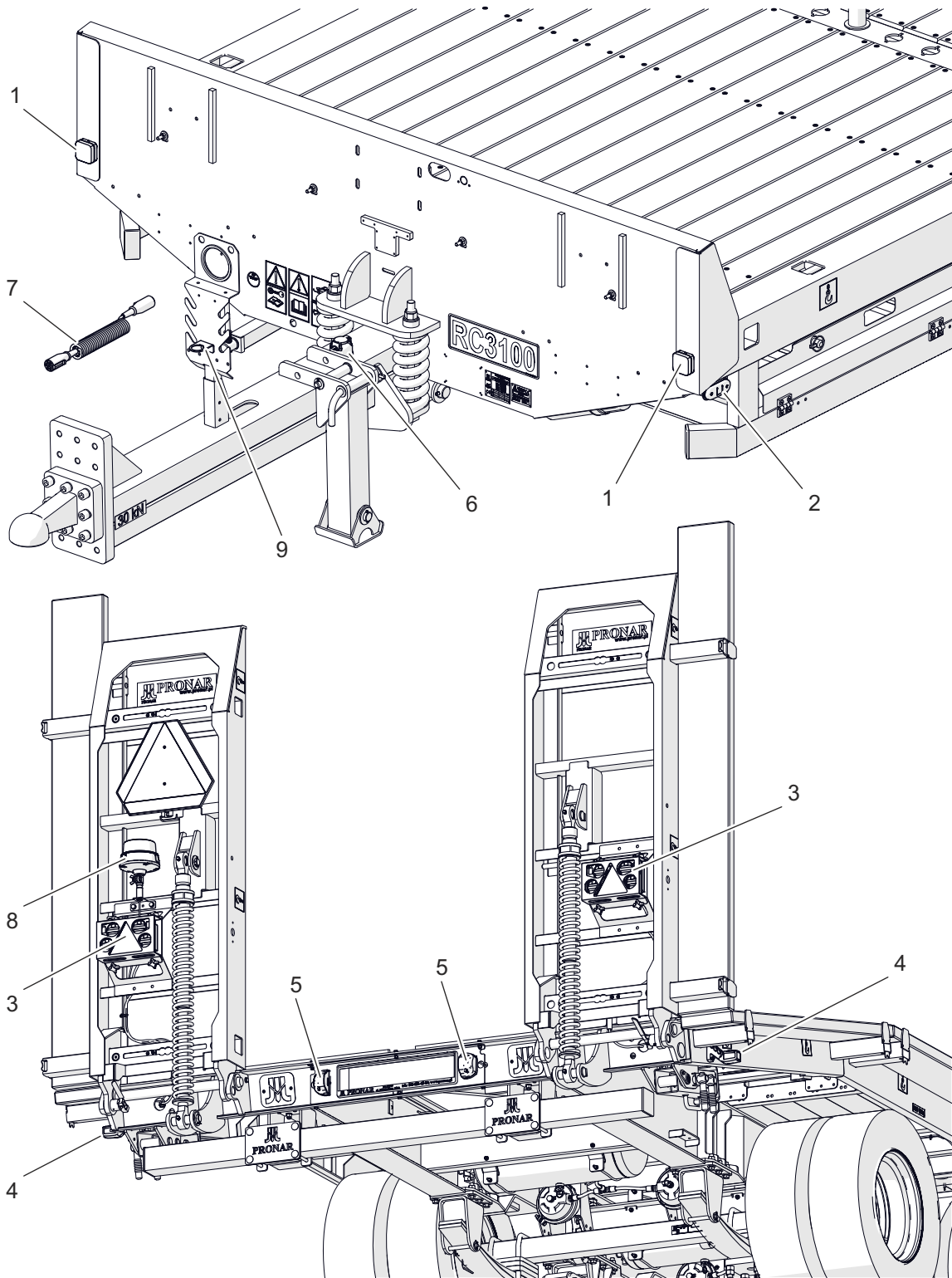

621-G.10-1

Figure 3.10 Arrangement of electrical system components

- | | | |
|-------------------------------------|---------------------------|------------------------|
| (1) front clearance lamp | (2) side clearance lamp | (3) rear lamp assembly |
| (4) rear clearance lamp | (5) licence plate light | (6) 7-pin socket (12V) |
| (7) connection lead 7pin-7pin (12V) | (8) beacon light (option) | |
| (9) electrical connection bracket | | |

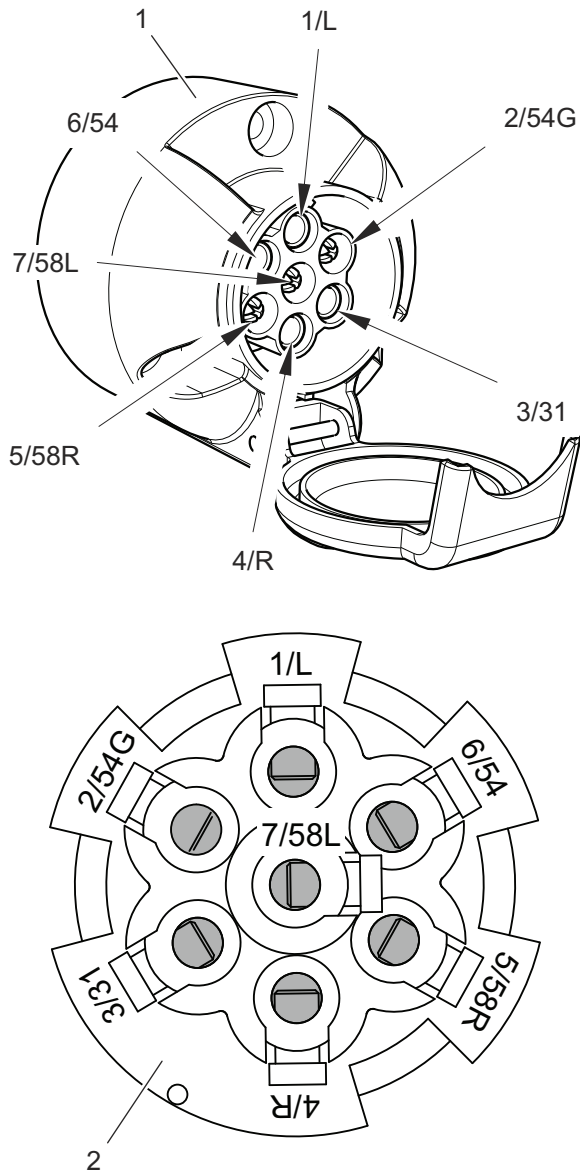

Figure 3.11 Connection socket
 (1) socket
 (2) view from the wiring harness side

The trailer's electrical lighting system is designed for 12 V DC supply.



ATTENTION

The trailer's lights work only when the trailer is connected to the agricultural tractor and the parking lights are ON.

Table 3.2 Markings of connection socket's connections

Marking	Function (lead colour)
1/L	Left indicator (yellow)
2/54G	Fog light (blue)
3/31	Ground (white)
4/R	Right indicator (green)
5/58R	Rear right parking light (brown)
6/54	STOP light (red)
7/58L	Rear left parking light (black)

Connection of the machine's electrical system with the tractor should be made through an appropriate connection lead that is part of the trailer's standard equipment.

If the trailer is not connected to tractor, the connection lead plug must be placed in the electrical connection bracket specially provided for that purpose.

G.3.6.621.08.1.EN

SECTION 4

CORRECT USE

4.1 HITCHING AND UNHITCHING THE TRAILER

HITCHING THE TRAILER TO THE TRACTOR HITCH

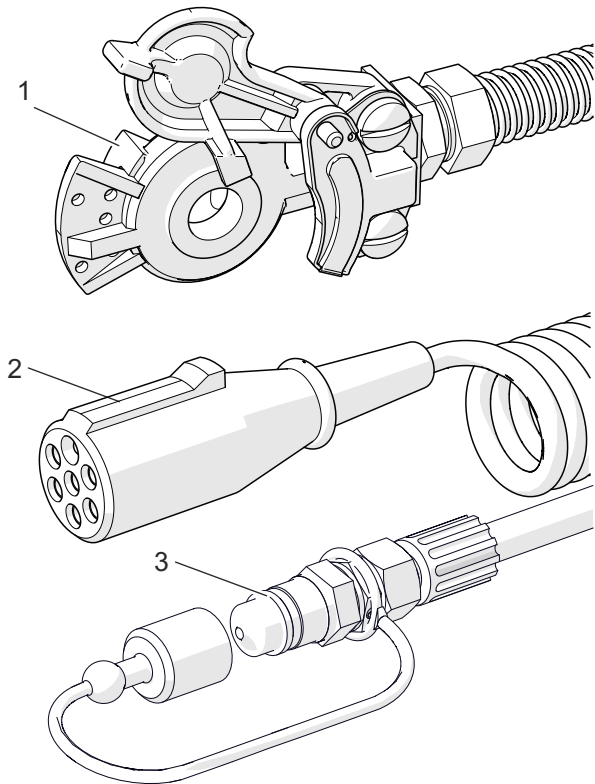

621-H.01-1

Figure 4.1 Trailer connections
 (1) 7-pin electrical plug (2) pneumatic plug
 (3) hydraulic plug

- Make sure that the trailer is immobilised with parking brake.

Pull brake mechanism clockwise until resistance is felt. Make certain that chocks are placed under one trailer wheel.

- Position agricultural tractor directly in front of drawbar eye.
- If the trailer is equipped with a hydraulic parking stand, connect

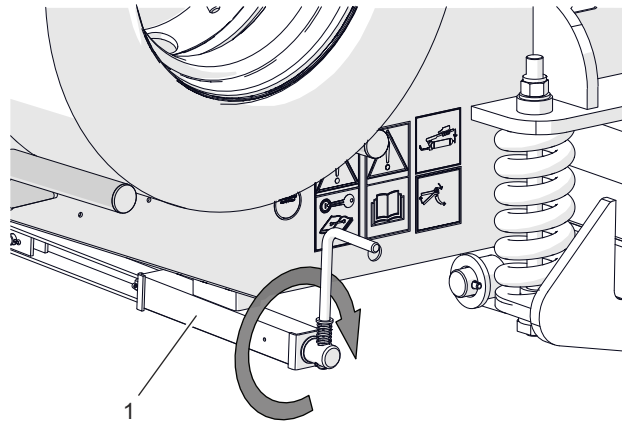

621-H.02-1

Figure 4.2 Parking brake
 (1) brake mechanism

hydraulic system conduits (3) - figure (4.1).

Read subsection (4.4).

- Reverse the tractor, hitch the trailer to the appropriate hitch.
- Check the hitch lock protecting the trailer against accidental unhitching.
- If the tractor is equipped with an

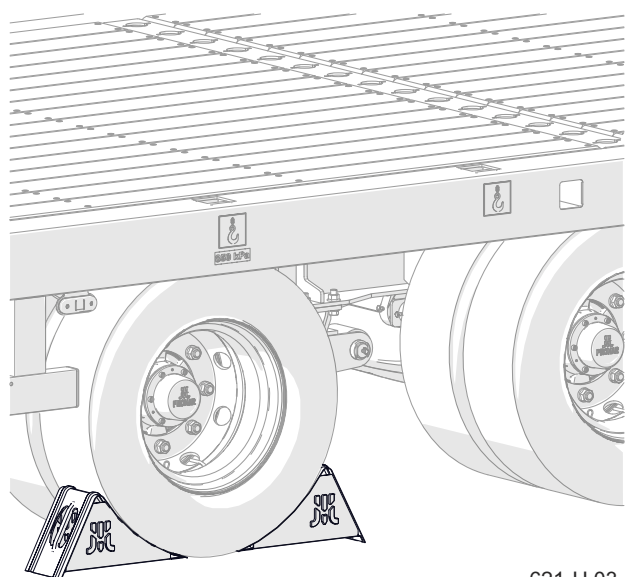

621-H.03-1

Figure 4.3 Chocks

automatic coupler, ensure that the hitching operation is completed and that drawbar eye is secured.

- Raise support foot, turn it to transport position and secure it with pin and cotter pin.

Read subsection (4.3), (4.4).

CONNECTING THE SYSTEMS

- Turn off the engine and remove key from ignition. Immobilise tractor with parking brake.
- Connect pneumatic braking system connections (1) to appropriate tractor sockets - figure (4.1).

First connect the conduit with a yellow cover (control conduit), then connect the pneumatic conduit with a red cover (supply conduit).



ATTENTION

In the event of a prolonged idle period of the trailer, the air pressure in the pneumatic brake system may be insufficient to release the brake shoes. In such a case, start the tractor's engine and air compressor and supplement air in the pneumatic system tank.

- Connect the electrical system lead - 7pin (2) - figure (4.1).



DANGER

When hitching, there must be nobody between the trailer and the tractor. When hitching the machine, tractor driver must exercise caution and make sure that nobody is present in the hazard zone.

When connecting the hydraulic and pneumatic conduits to the tractor, make sure that the hydraulic and pneumatic systems of the tractor and the trailer are not under pressure.

Ensure sufficient visibility during hitching.

- Depending on the trailer equipment, e.g. hydraulic ramps, winch, connect the appropriate hydraulic system conduits (3) - figure (4.1).

Ensure correct connection of the hydraulic conduits of the hydraulic winch. Conduit with return valve should be connected to "free drain" socket bypassing the tractor's hydraulic distributor.

ADDITIONAL INFORMATION

- After connecting all conduits make sure that they will not get entangled in moving parts of the tractor or trailer during work. If necessary, secure the conduits.
- Conduct daily inspection of the trailer.
- If the trailer is fully operational, one may commence work.
- Immediately before driving remove wheel chocks and release the parking brake.

**ATTENTION**

After completion of hitching check the security of the hitching pin.

Perform daily inspection of the trailer after hitching it to the tractor but prior to moving off.

Technical condition of the trailer cannot be verified by visual inspection if the trailer is not hitched to the tractor. Detailed information on the inspections is given in section 5.

**ATTENTION**

The machine may be connected to agricultural tractor if all connections (electrical, hydraulic and pneumatic ones) and the tractor hitch are according to the machine Manufacturer's requirements.

Turn the brake mechanism crank anticlockwise until resistance is felt.

H.3.6.621.01.1.EN

4.2 UNHITCHING



DANGER

Exercise caution when unhitching the trailer from the tractor. Ensure good visibility. Unless it is necessary, do not go between tractor and trailer.

Before disconnecting the conduits and drawbar eye, turn off tractor engine and remove key from ignition. Immobilise tractor with parking brake.

- Park the trailer on hard and level ground.
- Turn off tractor engine and remove key from ignition, immobilise the tractor with parking brake.
- Immobilise trailer with parking brake.
- Place chocks under one trailer wheel,

one chock in front of the wheel, the other behind the wheel - figure (4.3).

- Disconnect all conduits one at a time, protect the plugs against soiling and place them in special sockets.
- Lower the drawbar support to parking position.

Read subsection (4.3), (4.4).

- Unlock the hitch, start the tractor and drive tractor away from the trailer.



ATTENTION

When disconnecting the pneumatic conduits of the brake system, first disconnect the red conduit and only then disconnect the yellow conduit. Do NOT unhitch and park a loaded trailer.

H.3.6.621.02.1.EN

4.3 OPERATION OF MECHANICAL SUPPORT

SETTING THE SUPPORT TO DRIVING POSITION

- Immobilise tractor and trailer with parking brake.

The tractor must be connected with the trailer before the support is raised.

- Unlock the cotter pin (4) and remove the safety pin from the parking position (3).
- Turn the support to position (2).
- Insert the pin in position (5) and secure it with cotter pin (4).



ATTENTION

Do NOT move off or drive with the support in parking position. Be sure to change support to the driving position. Do NOT travel with the trailer if the support securing elements are damaged or lost – safety pin (3) and R-clip (4).

- Prior to moving off, release trailer's parking brake.

SETTING THE SUPPORT TO PARKING POSITION

- Immobilise tractor and trailer with parking brake.
- Unlock the cotter pin (4) and remove

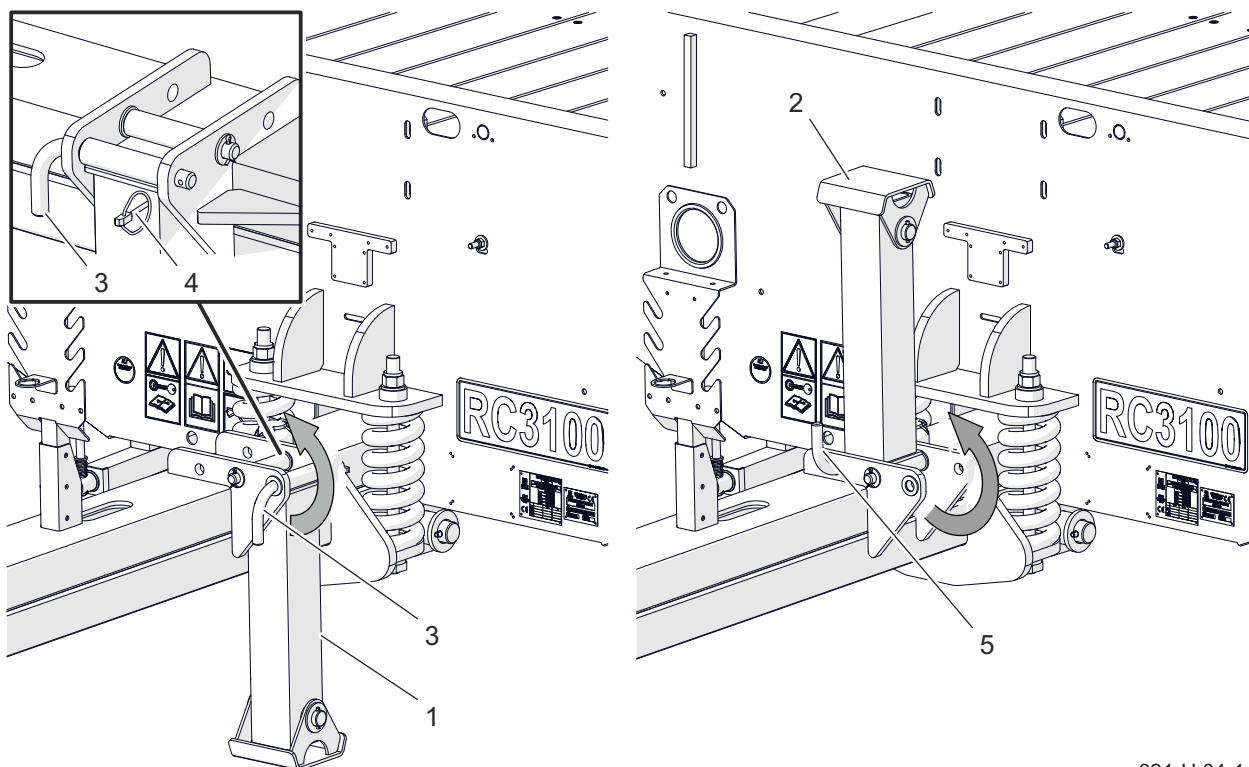

621-H.04-1

Figure 4.4 Support operation

(1) support in parking position

(2) support in driving position

(3) safety pin in parking position

(4) cotter pin of pin

(5) safety pin in driving position

the safety pin from position (5) – figure (4.4).

- Turn the support to parking position (1).
- Insert the pin in position (3) and secure it with cotter pin (4).

**DANGER**

Be especially careful when operating the support – this refers also to bystanders or helpers. While turning the support, be especially careful and do not place hands between the support mounting socket and the support. Danger of severing or crushing.

H.3.6.621.03.1.EN

4.4 HYDRAULIC SUPPORT OPERATION

SETTING THE SUPPORT TO DRIVING POSITION

- Immobilise tractor and trailer with parking brake.

The trailer must be hitched to the tractor. Hydraulic conduit marked with decal (7) must be connected to the hydraulic socket in tractor.

- Open the valve (5) by moving the valve lever to the open position "O" - decal (6).
- Operate the hydraulic distributor in the tractor in order to raise the support foot.
- Lock the support by moving the valve lever (5) to the closed position "Z" - decal (6).

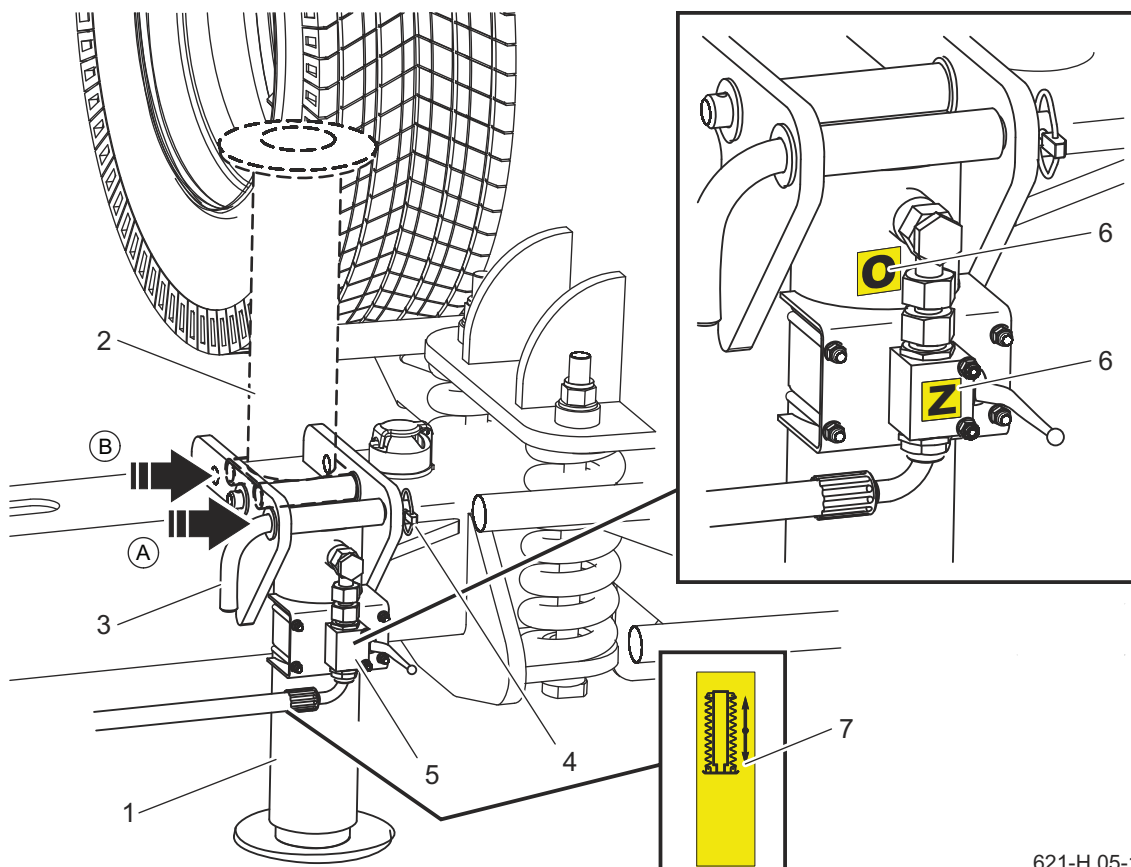

621-H.05-1

Figure 4.5 Support operation

- (1) support in parking position (2) support in driving position (3) safety pin
 (4) cotter pin of pin (5) cut-off valve
 (6) information decal "O/Z" (Opened/Closed) (7) information decal
 (A), (B) safety pin position

- Unlock cotter pin of pin (4), remove safety pin (3).
- Turn support foot to position (2).
- Insert the pin in position (B) and secure it with cotter pin (4).
- Prior to moving off, release trailer's parking brake.



ATTENTION

Do NOT move off or drive with the support raised only by means of the hydraulic cylinder. The support must be set to driving position.
Do NOT travel with the trailer if the support securing elements are damaged or lost – safety pin (3) and R-clip (4).

SETTING THE SUPPORT TO PARKING POSITION

- Immobilise tractor and trailer with parking brake.
- Unlock the cotter pin (4) and remove the safety pin from position (B) – figure (4.5).



DANGER

Be especially careful when operating the support – this refers also to bystanders or helpers. While turning the support, be especially careful and do not place hands between the support mounting socket and the support. Danger of severing or crushing.

- Turn the support to position (1).
- Insert the pin in position (A) and secure it with cotter pin (4).
- Set the cut off valve (5) to the open position “O” - decal (6).
- Operate the hydraulic distributor in the tractor in order to lower the support foot.
- Drawbar hitching eye should be slightly raised with regard to the tractor hitch in order to facilitate un-hitching the trailer.
- Lock the support by moving the valve lever (5) to the closed position “Z” – decal (6).

H.3.6.621.04.1.EN

4.5 LOWERING AND RISING THE RAMPS (MANUAL)

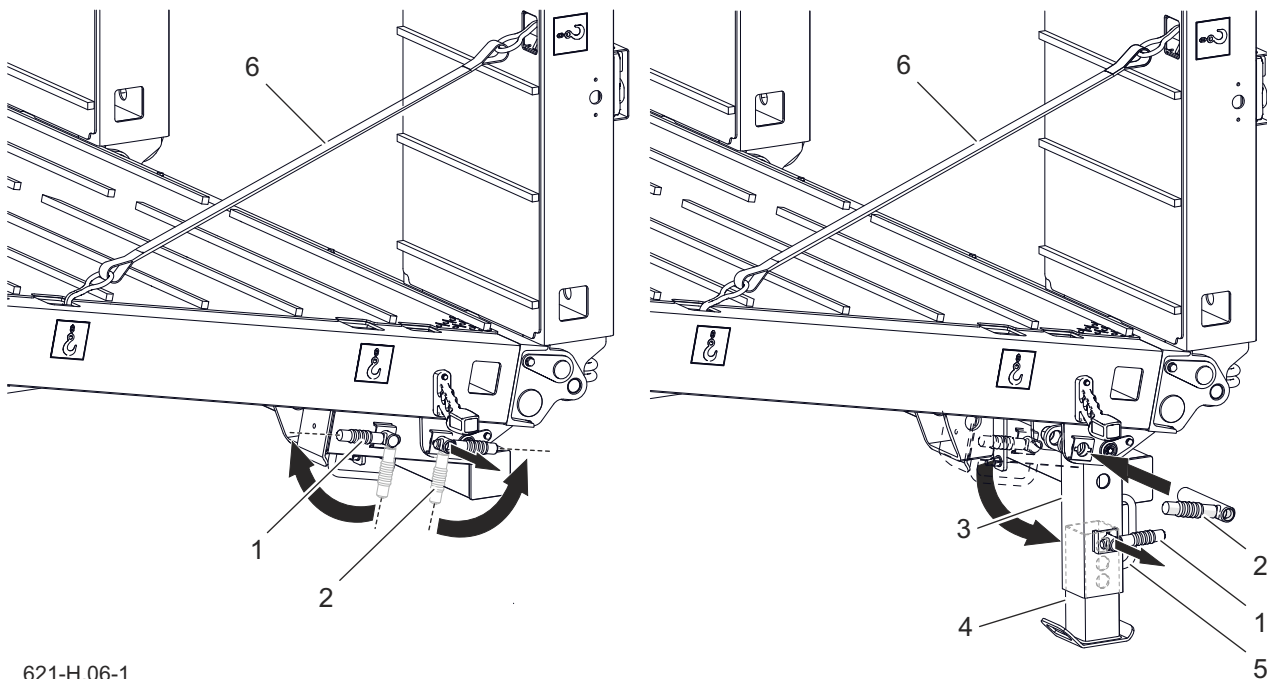

621-H.06-1

Figure 4.6 Rear support

(1) upper pin

(2) lower pin

(3) support

(4) support foot

(5) support handle

(6) safety strap



DANGER

Due to their large weight and range, exercise due caution when unfolding the ramps.
Do NOT stand behind the ramp when rising/lowering the ramp.
Careless operation of the ramps may cause serious accidents.
Ensure sufficient space for unfolding the ramps.



ATTENTION

Always unfold both supports when loading and unloading the trailer.
Do NOT drive or move off with the rear supports unfolded.
Do NOT park unhitched and loaded trailer resting on the rear supports.
The ramps must not be used as load securing points.
Lower the ramps until they fully rest on the ground.

The ramps (left and right) can be set in two selected positions only (lowered - loading, unloading and raised - transport, travel).

LOWERING THE RAMPS

- Park the trailer and tractor on hard and level ground.
- Immobilise the tractor and trailer with parking brake. Place chocks under one trailer wheel.

- Unlock and remove the safety pin (2) of the support (3) - figure (4.6).

Raise the support slightly up to make it easier to remove the safety pin.

- Holding the handle (5), unfold the support and secure it with the pin (2).
- Unlock and remove the pin (1).

To facilitate the removal of the pin, raise the foot until the pin rotates easily.

- Slide out the support foot (4) to the desired height and secure it by locking with a pin (1).



DANGER

When unfolding and folding the rear supports of the trailer, be especially careful because there is a risk of crushing fingers.

- Unfold the other rear support in the same way.
- Loosen and remove the safety straps (6) - figure (4.6).
- Release the ramp's spring catch mechanism.

Pull the lever back to position (2) - figure (4.7). In this position, the catch lever cannot be automatically closed.

- Lower the ramp to the working position.
- Repeat the procedure for the second ramp.

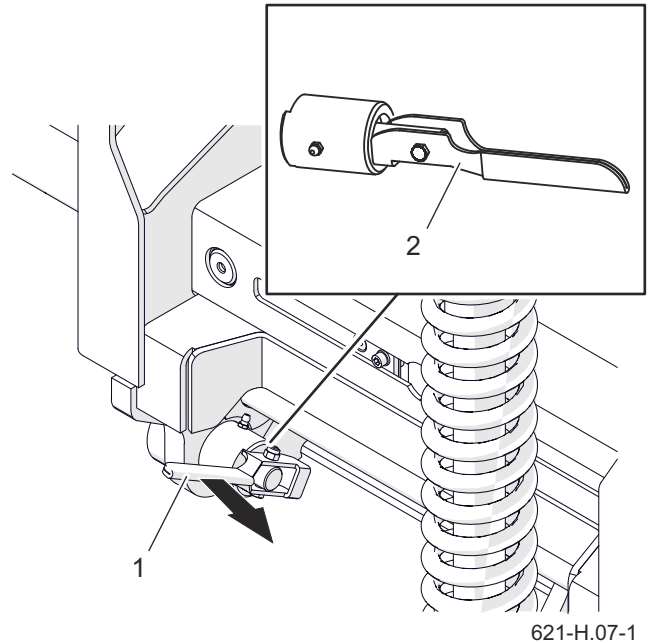

Figure 4.7 Spring catch
(1) latch lever in locking position
(2) latch lever in releasing position

RISING THE RAMPS

- Move the spring catch to the ramp locking position (1)- figure (4.7).
- Manually raise the ramp to the folded (transport) position.
- Check that the spring catch pins properly lock the ramp in the raised position.



ATTENTION

After finishing ramps folding, make sure that spring catches are in ramp locking position. After folding, the ramps must be secured with safety straps. Do NOT drive when the ramps are not secured. Safety straps must be properly tensioned to minimize the ramp movements during travel. Before moving off, check that the ramps are raised and properly secured.

- Install the safety straps (6).
- Unlock and remove the pin (1) locking the support foot (4) - figure (4.6).
- Slide the foot in (4) and lock it with the pin (1) - figure (4.6).
- Unlock and remove the pin (2).
- Fold the support (3) to transport position and lock it with the pin (2).

H.3.6.621.05.EN

4.6 LOWERING AND RISING THE RAMPS (HYDRAULIC)

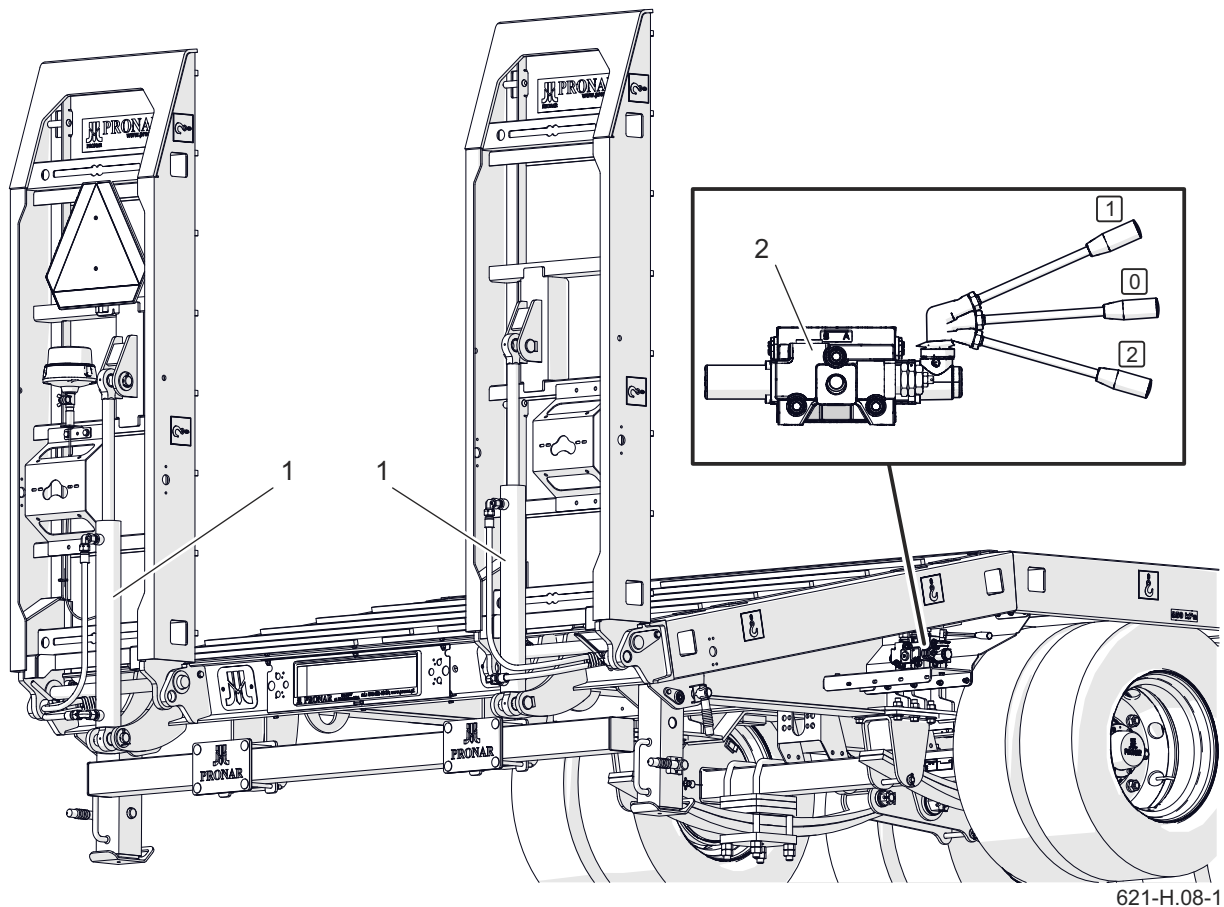

621-H.08-1

Figure 4.8 Hydraulic ramps
(1) hydraulic cylinder (2) distributor

The ramps can be raised and lowered hydraulically by means of double-acting cylinders (2) through a single-section hydraulic distributor (2) located in the rear part of the frame, on the right side of the trailer - figure (4.8). Working positions of the hydraulic distributor:

- (0) Neutral position.
- (1) Raising the ramps.
- (2) Lowering the ramps.

LOWERING THE RAMPS

- Park the trailer and tractor on hard and level ground.



DANGER

Due to their large weight and range, exercise due caution when unfolding the ramps. Do NOT stand behind the ramps when rising/lowering the ramps. Careless operation of the ramps may cause serious accidents. Ensure proper visibility of the ramp unfolding area, observe the process of lowering and folding the ramps at all times. The ramps' hydraulic system is under high pressure.

- Immobilise the tractor and trailer with parking brake. Place chocks under one trailer wheel.
- Unlock and remove the safety pin (2)

of the support (3) - figure (4.6).

Raise the support slightly up to make it easier to remove the safety pin.

- Holding the handle (5), unfold the support and secure it with the pin (2).
- Unlock and remove the pin (1).

To facilitate the removal of the pin, raise the foot until the pin rotates easily.

- Slide out the support foot (4) to the desired height and secure it by locking with a pin (1).
- Unfold the other rear support in the same way.
- Release the ramp's spring catch mechanism.

Pull the lever back to position (2) - figure (4.7). In this position, the catch lever cannot be automatically closed.

- Lower the ramps with the aid of the tractor's hydraulic system.

Move the levers of the hydraulic distributor (2) to position "2" - lowering the ramps.

RISING THE RAMPS

- Move the spring catch to the ramp locking position (1)- figure (4.7).
- Raise the ramps with the aid of the tractor's hydraulic system.

Move the levers of the hydraulic distributor (2) to position "1" - rising the ramps.

- Check that the spring catch pins properly lock the ramp in the raised position.
- Unlock and remove the pin (1) locking the support foot (4) - figure (4.6).
- Slide the foot in (4) and lock it with the pin (1) - figure (4.6).
- Unlock and remove the pin (2).
- Fold the support (3) to transport position and lock it with the pin (2).



ATTENTION

After finishing ramps folding, make sure that spring catches are in ramp locking position.

After folding, the ramps must be secured with safety straps. Do NOT drive when the ramps are not secured.

Safety straps must be properly tensioned to minimize the ramp movements during travel.

Before moving off, check that the ramps are raised and properly secured.

H.3.6.621.06.1.EN

4.7 WINCH OPERATION

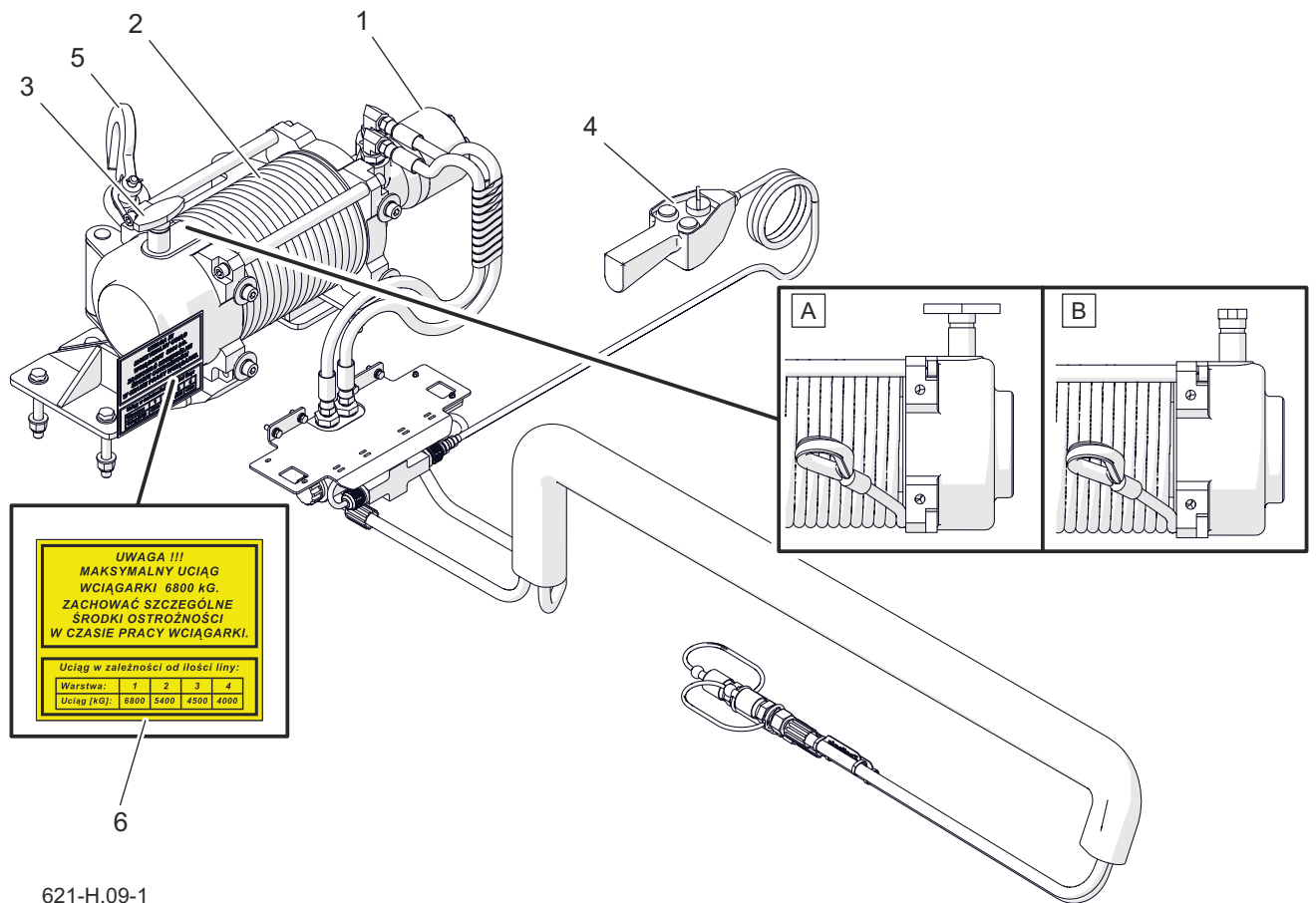

621-H.09-1

Figure 4.9 Winch operation

- (1) hydraulic motor (2) drum (3) gear lever
 (4) wired control or remote control (5) hook (6) warning decal
 (A) "IDLE" position of the lever (B) "WORK" position of the lever

- Immobilise tractor and trailer with parking brake, place chocks under the trailer rear wheel. Ensure that unauthorised persons do not have access to the tractor cab.
- Unlock and lower the ramps.
- In order to disengage the gear, set the lever (3) to the "IDLE" position to unwind the rope freely - for this purpose pull the lever up and turn by 90°.



DANGER

When operating the winch, be especially careful because the winch elements are rotating. Do NOT wear loose clothing, straps or whatever that may become wrapped round the rotating winch drum. The hydraulic system of the winch is under high pressure. Do NOT go under and over the rope during winch operation. Do NOT stand between the winch and pulled load. Keep a safe distance from rope and pulled load during winch operation.

**DANGER**

Avoid accidental turning off the winch by disconnecting it mechanically from the power supply. When the winch is not in use, set the gear lever to the "OUT" or "IDLE" position.

The winch motor must not be started in the "IDLE" position.

- Extend the winch rope along the load platform and fasten the load with the hook (5).
- Switch the lever (3) to the "WORK" position - to do this turn the lever by 90°.

Do not start the engine until the gear meshes. In order to mesh the gear pull the rope.

TIP

The winch can also be operated using a wireless remote control.

**ATTENTION**

The machines pulled onto the trailer must have axles and wheels.

Do NOT move the tractor and trailer if the winch rope is extended and attached to the load located outside the trailer.

Do NOT use additional accessories to extend the winch rope.

Do NOT unwind the rope to its full length. At least 5 rope fakes must remain on the drum.

Do not exceed the maximum winch pulling force. The maximum winch pulling force and the winch pulling force depending on the number of rope layers wound on the drum is shown in the warning decal (6). The decal is located on the trailer's front wall.

- Pre-tension the winch rope using the remote control (4).
- Check the hook fixing (5).
- Pull the load onto the trailer platform.

The winch is not equipped with locking mechanism. The load pulled onto the trailer platform should be properly secured.

H.3.6.621.07.1.EN

4.8 LOADING

STANDARD SIZE LOADS



DANGER

Uneven arrangement of the load may cause overloading of the trailer's axle.
During work, keep a safe distance from overhead electrical power lines.
When loading or unloading the trailer, bystanders must exercise caution and keep a safe distance from danger zones.

The trailer is designed for transporting agricultural and construction machines and the loads which can be properly secured against moving during travel (loads placed in boxes, containers, on pallets etc.). Standard size loads are all loads permitted for transport, whose dimensions do not exceed allowable dimensions specified by the road traffic regulations in force in the country where the trailer is used. Load must not extend beyond the outline of the load platform.

The trailer must be positioned to travel forwards. Loading of trailer may only take place when the machine is hitched to tractor. The load must be arranged in such a manner that it does not overload the axle or hitch system of the tractor and trailer. Loading should only take place, when trailer is placed on flat level surface and hitched to tractor. Depending on the type of



ATTENTION

Do NOT exceed the trailer's maximum carrying capacity.
People or animals must not be carried on the trailer.

transported load, use appropriate number and type of protections. Use transport lugs to fix the load - figure (4.13).

Keep a safe distance. Do not allow anyone to approach the place where works are carried out.

Load should be uniformly distributed along the length and width of the platform in order to ensure proper distribution of axle loads and proper stability of the trailer. The permissible loading height defined by the road traffic regulations and permissible design load of the trailer must not be exceeded. When loading goods on pallets, pay special attention to their arrangement on the load box. Pallets must be secured against the displacement on the platform. Pallets must not be stacked in layers.

Hoisting crane, overhead crane of proper lifting capacity, winch (if included in the trailer's equipment) or additional agricultural tractor may be used for loading the trailer.

When using a tractor for loading the trailer, remember to ensure that the gross

weight (tractor + loaded machine) does not exceed the trailer's maximum carrying capacity. Otherwise, the ramps, drawbar or other elements of the trailer may get damaged.

Before loading, ensure enough space and very good visibility.

public roads only if the requirements specified by the road traffic regulations are met and a travel permit is obtained from a competent office. Driving on non-public roads is not limited by road traffic regulations.

Oversize load may not fully load the floor extension elements.

OVERSIZE LOADS

Oversize loads are the loads whose dimensions exceed allowable dimensions specified by the road traffic regulations in force in the country where the trailer is used.

Oversize loads may be transported on



ATTENTION

Do NOT exceed the trailer's maximum carrying capacity.

Load placed on the platform must be uniformly distributed and properly secured.

The load must be arranged in such a way that it does not threaten the stability of the trailer and does not hinder driving.

Loading should be carried out by a person having appropriate authorisation for operating the equipment (if required).

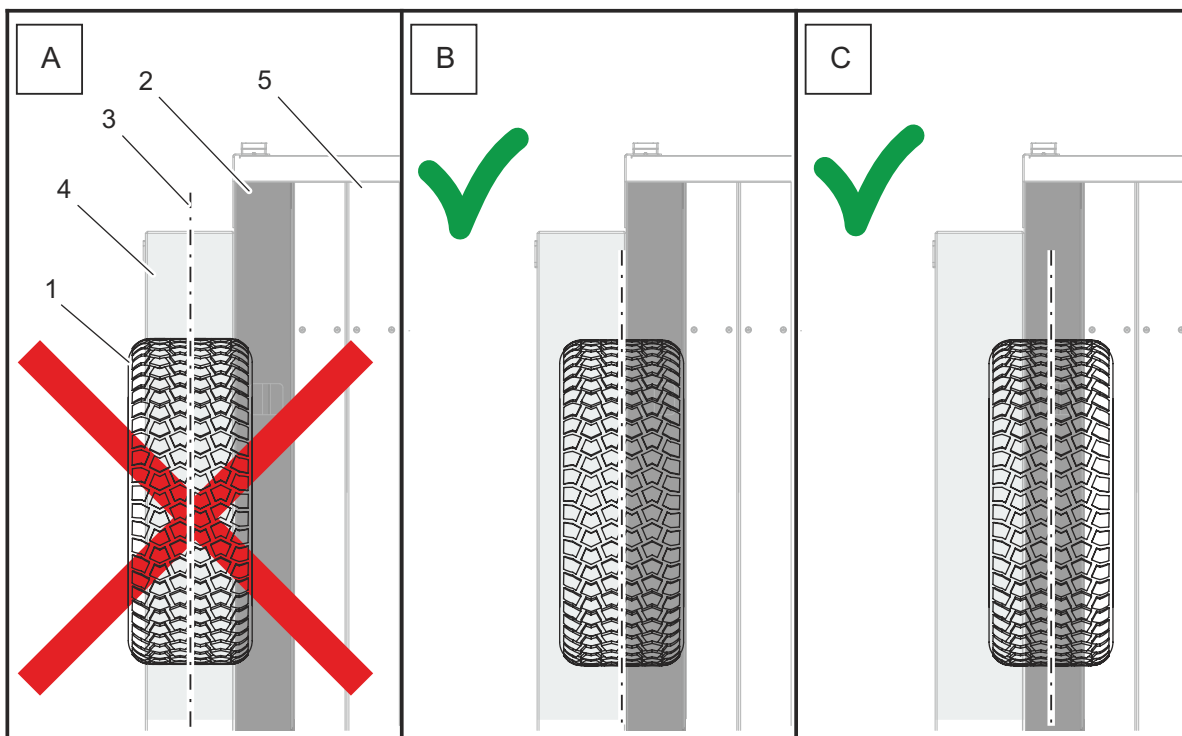

621-H.10-1

Figure 4.10 Position of load on extension planks

(1) wheel of transported machine (2) extreme longitudinal member of the trailer
(3) wheel axis of transported machine (4) extension plank (5) load platform



ATTENTION

Before loading and unloading, lower the ramps until they fully rest on the ground. Lowered ramps should be at the same height. Rear supports must be unfolded.



DANGER

Overloading the trailer, erroneous loading and securing of the load is the most frequent cause of accidents during transport. Uneven arrangement of the load may cause overloading of the trailer's axle. People or animals must not be carried on the trailer.

To install the extensions - figure (4.11):

- set the extension brackets (1) to the unfolded position (F),
To release the lock, raise the latch plate (4).
- pull the bracket (1) out of the profile (3) until it locks in the unfolded

position (F),

- install the extension planks according to figure 4.11.

Wheels, brackets, supports or other load elements, item (1), figure (4.10), which carry the machine load, must be arranged

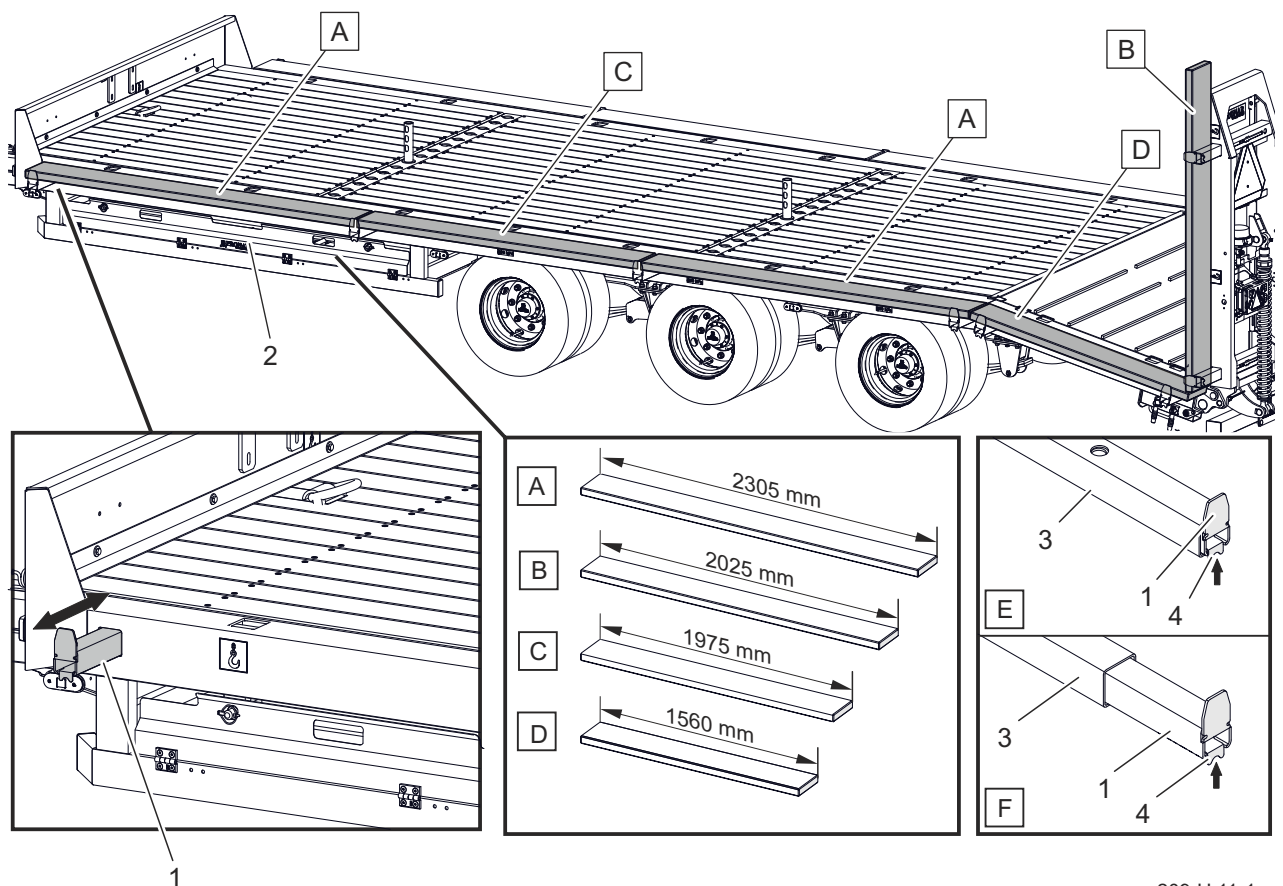

209-H.11-1

Figure 4.11 Load platform extensions

- | | | |
|----------------------------------|---|--------------------------------|
| (1) extension bracket | (2) holder for storing extension planks | (3) extension profile |
| (4) latch plate | (A) external plank | (B) ramp plank |
| (C) middle plank | (D) rear plank | (E) bracket in folded position |
| (F) bracket in unfolded position | | |

in such a manner as to ensure that at least a half of the element is supported on a fixed section of the load platform (planks (5) and the extreme longitudinal member (2) of the low chassis trailer - figure (4.10)). When transporting oversized loads, switch on and check additional warning lights for

oversize loads.

- Install electric cable between the braked and secured trailer and the agricultural tractor.
- Loosen star knobs (6).
- Slide out the boards and lock them with the knob.

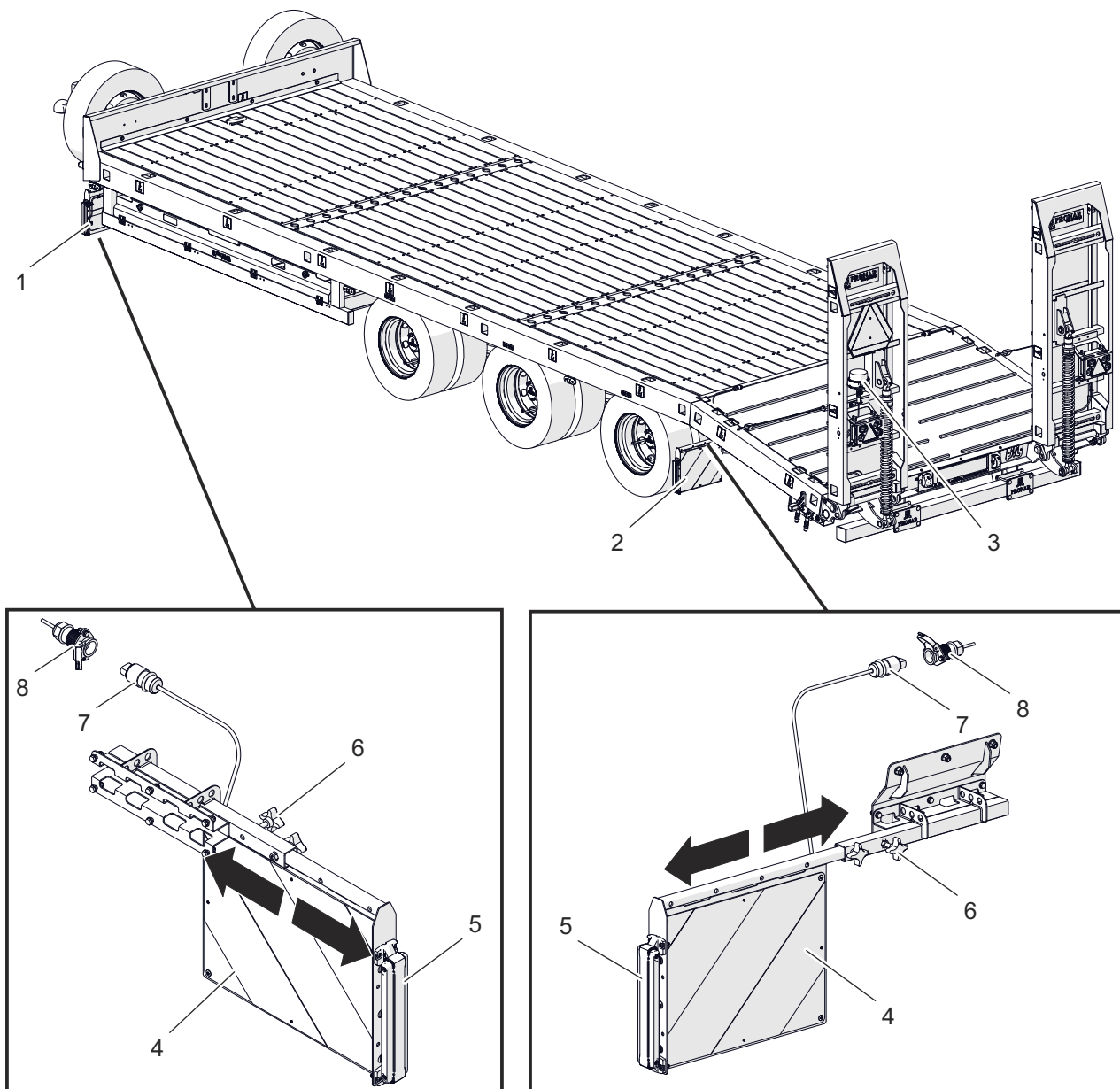

621-H.14-1

Figure 4.12 Markings for oversized loads

(1) front marking board

(2) rear marking board

(3) beacon light

(4) warning board

(5) board clearance lamp

(6) star knob

(7) wiring harness

(8) 3-pin electrical plug

- Connect the lamp plugs (7) to the trailer sockets (8).
- Switch on the lighting system, check if the clearance lamps of the marking boards (5) and the beacon light (3) are ON.

**DANGER**

Do not use the trailer when the lighting system is out of order.
Be especially careful and vigilant when transporting oversized load.

H.3.6.621.08.1.EN

4.9 SECURING LOAD

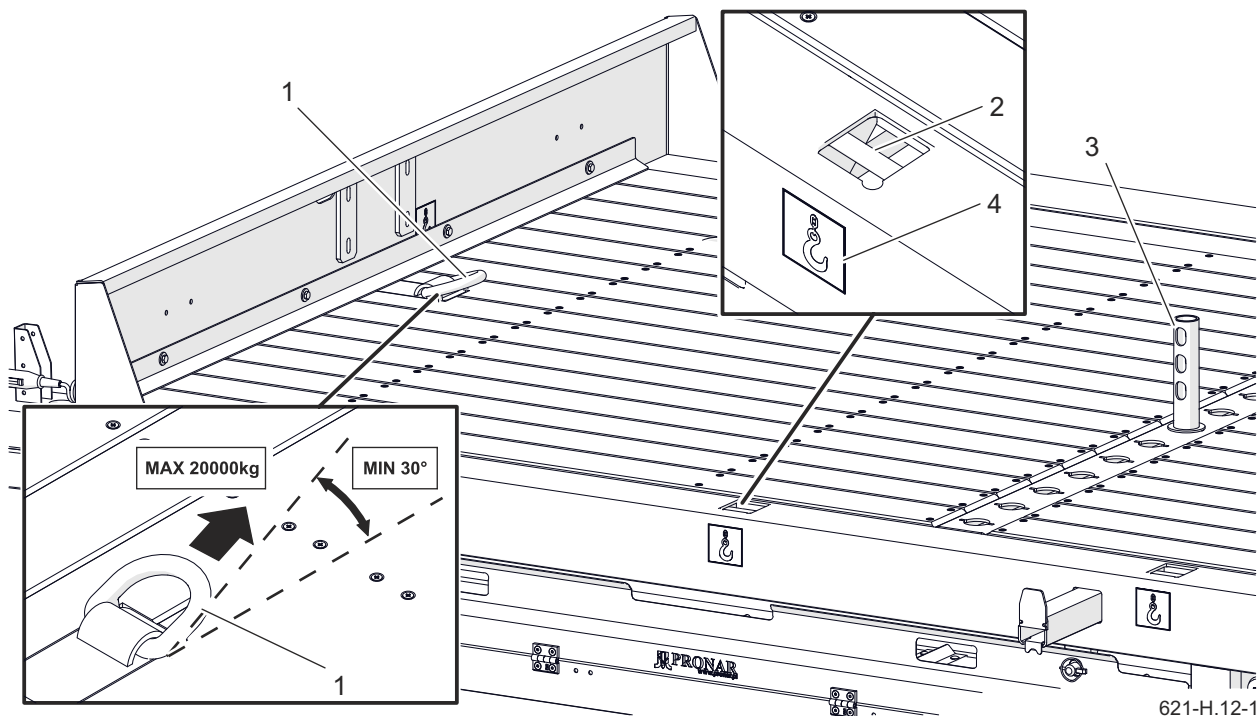

Figure 4.13 Fixing lugs

(1) fixing eye

(2) load catch

(3) limiter

(4) information decal

Regardless of the type of load carried, the user is obliged to secure it in such a manner that the load is unable to move freely on the load platform and pose a threat to other road users during transport.

The load must be properly secured against moving by means of straps, ropes, chains or other securing measures fitted with a tightening mechanism. The extent of protection depends on loading method, type of load and size of load. If load is to be transported on slopes and/or in strong gusty winds conditions, limit the load height according to existing conditions.

Regardless of the type of load carried,

the user is obliged to secure it in such a manner that the load is unable to spread and cause contamination of the road.

It is impossible to describe all methods of loading due to the diversity of materials, tools, means of fixing and securing a load. While working be guided by caution and own experience. The trailer user must carefully read the regulations concerning road transport and comply with them.

In the front of the low chassis trailer's floor there is a fixing eye (1) for securing loads. On the extreme longitudinal members of the floor and in the ramp sheathing there are sockets in which load catches (2) for

fastening loads are located - figure (4.13). The optimum angle for attaching securing measures is 30° . Increased load applied to fixing lug or wrong attaching angle may cause damage to fixing lug and lead to re-location of load.

To limit the load space, limiters (additional equipment) can be used - figure (4.14). The position of the limiter body (1) on the platform can be changed by locking its position in the floor sockets (2).

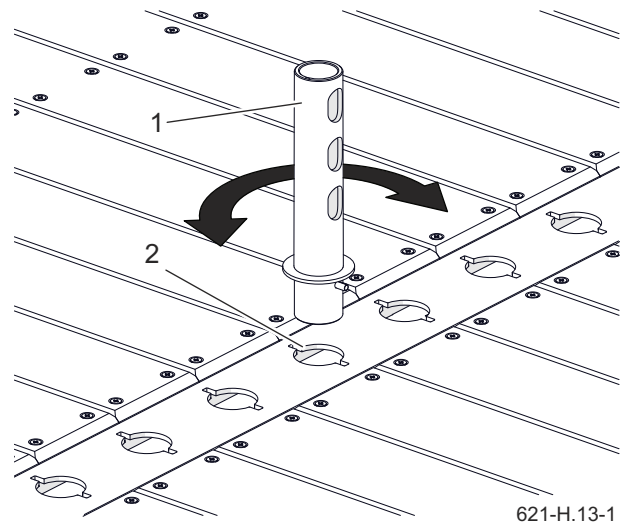

Figure 4.14 Limiter
(1) limiter body

(2) socket

H.3.6.621.09.1.EN

4.10 LOAD TRANSPORT

When driving on public roads, respect the road traffic regulations, exercise caution and prudence.

- Prior to moving off, make sure the trailer is fully operational. Towing the trailer with damaged lighting system, braking system, drawbar or running gear is forbidden.
- Before moving off, make sure that there are no bystanders, especially children, near the trailer or the tractor. Ensure that the driver has sufficient visibility.
- Make sure that the trailer is correctly hitched to the tractor and tractor's hitch is properly secured.
- The trailer must not be overloaded, loads must be uniformly distributed so that the maximum permissible axle loads are not exceeded. The trailer's maximum carrying capacity must not be exceeded as this can damage the trailer and pose a risk to the operator or other road users.
- Permissible design speed and maximum speed allowed by road traffic law must not be exceeded. The towing speed should be adapted to the current road conditions, load carried by the trailer, road surface conditions



ATTENTION

Do NOT exceed the trailer's maximum carrying capacity.
Load placed on the platform must be uniformly distributed and properly secured.
The load must be arranged in such a way that it does not threaten the stability of the trailer and does not hinder driving.

and other relevant conditions.

- When not connected to the tractor, the trailer must be immobilised using parking brake and with chocks placed under the wheels. Do NOT leave unsecured trailer. In the event of machine malfunction, pull over on the hard shoulder avoiding any risk to other road users and position reflective warning triangle according to traffic regulations.
- When driving, comply with all road traffic regulations, indicate an intention to turn using indicator lamps, keep all road lights and indicator lights clean at all times and ensure they are in good condition. Any damaged or lost lamps or indicator lights must be immediately repaired or replaced.
- Avoid ruts, depressions, ditches or driving on roadside slopes. Driving across such obstacles could cause the trailer or the tractor to suddenly

tilt. This is of special importance because loaded trailer's centre of gravity is higher, which reduces safety. Driving near ditches or channels is dangerous as there is a risk of the wheels sliding down the slope or the slope collapsing.

- It is recommended that another person should help in reversing or making difficult manoeuvres. This person should observe the tractor and trailer combination. This person should be visible all the time to the tractor driver as well as be especially careful and keep a safe distance from danger zones.
- Speed must be sufficiently reduced before making a turn or driving on an uneven road or a slope.
- When driving, avoid sharp turns

especially on slopes.

- Monitor trailer's behaviour when travelling on an uneven terrain.
- Prolonged driving across steep ground may lead to loss of braking efficiency.
- Please note that the braking distance of the tractor and trailer combination is substantially increased at higher speeds and loads.
- Exercise particular caution when driving with the load under electrical power lines, bridges, viaducts etc.
- Oversize loads may be transported on public roads only if the requirements specified by the road traffic regulations are met and a travel permit is obtained from a competent office. Driving on non-public roads is not limited by road traffic regulations.

H.3.6.209.07.1.EN

4.11 UNLOADING

The trailer must be positioned to travel forwards and be hitched to the tractor. Unloading should only take place when the trailer is placed on level and hard surface. Bulky materials should be unloaded using a loader, conveyor or forklift truck. The machines transported on the trailer platform should be unloaded using a second towing vehicle. Self-propelled machine should be driven down the trailer platform.

During work, ensure good visibility and exercise due caution. Immobilise tractor and trailer with parking brake and switch off tractor engine. Place wheel chocks

under trailer wheel. Just before unloading, remove all securing elements (belts, ropes, etc.). Unloading the trailer should be carried out in accordance with the general principles of workplace health and safety.



ATTENTION

Lower the ramps until they fully rest on the ground and unfold both rear supports. Otherwise, when a machine is driven off the load platform, the trailer will have a tendency to raise the drawbar, which may cause damage to the tractor hitch or trailer drawbar eye.

If unloading takes place on soft ground, place planks, plates or other materials under the ramps and rear supports to prevent them from sinking into the ground.

H.3.6.621.11.1.EN

4.12 PROPER USE AND MAINTENANCE OF TYRES

- When working with tyres, the trailer should be secured against rolling by placing chocks under the wheel. Wheels can be taken off the trailer axle only when the trailer is not loaded.
- Repair work on the wheels or tyres should be carried out by persons trained and entitled to do so. This work should be carried out using appropriate tools.
- Regularly check if the nuts fixing the wheels are properly tightened. Additionally, check the wheel nuts after the first use of the trailer and every 2–3 hours of the trailer travel during the first month of the trailer use.
- Regularly check and maintain correct air pressure in tyres according to Operator's Manual (especially if trailer is not used for a longer period).
- Air pressure in tyres should be also checked during the whole day of intensive work. Please note that higher temperatures could raise tyre pressure by as much as 1 bar. At high temperatures and pressure, reduce load or speed.
- During wheel dismounting, memorize the sequence of wheel and spacer ring dismounting. The smaller ring is mounted on the wheel axle drum side. The larger ring is mounted on the external side.
- Do not release air from warm tyres to adjust the pressure or the tyres will be underinflated when temperatures return to normal.
- Tyre valves should be protected with caps to avoid soiling.
- Do not exceed the trailer's maximum design speed.
- When the trailer is operated all day, stop working for a minimum of one hour at noon.
- Take breaks during driving in order to cool down tyres.
- Avoid potholes, sudden manoeuvres or high speeds when turning.

H.3.6.209.09.1.EN

4.13 TRAILER CLEANING

Trailer should be cleaned depending on requirements and before longer idle periods (e.g. before winter period). Wash trailer each time after unloading the material which may cause corrosion of trailer components. Before using pressure washer the user is obliged to acquaint himself with the operating principles and recommendations concerning safe use of this equipment.

TRAILER CLEANING GUIDELINES

- Remaining material should be removed from the load box before cleaning the trailer (sweep or blow with compressed air).
- To clean the trailer, use only clean running water or water with a cleaning detergent additive with neutral pH.
- Using pressure washer increases washing effectiveness, but particular care must be taken during work. During washing, washer nozzle may not be closer than 50 cm from the surface being cleaned.
- Water temperature should not exceed 55 °C.
- Do not direct water stream directly at system elements and equipment of the trailer i.e. control valve, braking force regulator, brake cylinders, pneumatic, electric and hydraulic plugs, lights, electrical connections, information and warning decals, identification plate, conduit connections and lubrication points etc. Great water jet pressure may damage these elements. During washing, try not to wet load platform planks.
- For cleaning and maintenance of plastic coated surfaces it is recommended to use clean water or special preparations designed for this purpose.
- Do not apply organic solvents, preparations of unknown origin or other substances, which may cause damage to lacquered, rubber or plastic surfaces. In the event of doubt it is recommended to make a test on an unseen surface area.
- Surfaces smeared with oil or grease should be cleaned by application of benzene or other degreasing agents and then washed with clean water with added detergent. Comply with recommendations of the Manufacturer of cleaning agents.
- Detergents should be kept in original containers, optionally in replacement containers, but very clearly marked.

Preparations may not be stored in food and drink containers.

**DANGER**

Carefully read the instructions for application of detergents and maintenance preparations. While washing with detergents wear appropriate protective clothing and goggles protecting against splashing.

- Ensure cleanliness of elastic conduits and seals. The plastic from which these elements are made may be susceptible to organic substances and some detergents. As a result of long-term reaction of some substances, the ageing process may be accelerated and risk of damage increased. Rubber elements should be maintained with the aid of special preparations after previous thorough washing.
- After completed washing wait until the trailer is dry and then grease all inspection points according to recommendations. Remove excess oil or grease with a dry cloth.
- Observe environmental protection principles and wash trailer in a place designed for this purpose.
- Cleaning and drying of the trailer must take place at temperatures above 0 °C.
- After washing and drying, trailer should be greased at all control points regardless of previous date of lubrication.
- We recommend that wooden floor should be protected and preserved once a year using commercially available preparations.

H.3.6.621.13.1.EN

4.14 STORAGE

- Trailer should be kept in closed or roofed building.
- Do not store loaded trailer.
- If the machine will not be used for a long time, it is essential to protect it from adverse weather, especially rust and accelerated tyre deterioration. During this time the machine must be unloaded. Trailer should be very carefully washed and dried.
- Corroded places should be cleaned of rust, degreased and protected using undercoat paint and then painted with surface paint according to colour scheme.
- In the event of a prolonged work stoppage, it is essential to lubricate all components regardless of the date of the last lubrication.
- Wheel rims and tyres should be carefully washed and dried. During longer storage of unused trailer it is recommended that every 2 to 3 weeks the machine may be moved a bit so that the place of contact of tyres with ground is changed. The tyres will not be deformed and maintain proper geometry. Also, air pressure in tyres should be inspected from time to time and, if necessary, pressure should be increased to appropriate value.

H.3.6.621.14.1.EN

SECTION 5

TECHNICAL INSPECTION
SCHEDULE

5.1 BASIC INFORMATION

This section describes all periodic inspection activities which must be carried out by the user according to the specified schedule. Regular inspections of technical condition and performance of maintenance procedures are essential for keeping the trailer in good technical condition. The maintenance activities which the user may perform by himself are described in section *Maintenance*.

Repairs during the warranty period may only be performed by the Authorised Points of Sale and Service (APSS). In the event of unauthorised repairs, changes to factory settings or other actions which



ATTENTION

The trailer must not be used when not in working order.

The trailer may only be towed when the brake system, lighting system, drawbar and axle system are fully operational.

Repairs during the warranty period may only be performed by authorised service points.

are not regarded as possible for the trailer operator to perform (not described in this Operator's Manual), the manufacturer's warranty becomes void.

Warranty inspection of the trailer may be carried out only by an authorized warranty service point.

I.3.1.526.01.1.EN

5.2 PERIODIC INSPECTIONS OF THE TRAILER

Table 5.1 Inspection categories

Category	Description	Carried out by	Frequency
A	Daily inspection	Operator	Inspection conducted daily before the first start or every 10 hours of continuous operation in shift mode.
B	Maintenance inspection	Operator	Inspection carried out periodically every 1000 km or every month of trailer use, whichever occurs first. Daily inspection should be carried out each time before this inspection.
C	Maintenance inspection	Operator	Inspection carried out periodically every 3 months. Daily inspection and monthly inspection should be carried out each time before this inspection.
D	Maintenance inspection	Operator	Inspection made periodically every 6 months. Daily inspection, monthly inspection and 3-monthly inspection should be carried out each time before this inspection.
E	Maintenance inspection	Operator	Inspection made periodically every 12 months. Daily inspection, monthly inspection and 3-monthly inspection should be carried out each time before this inspection.
F	Maintenance inspection	Service ⁽¹⁾	Inspection carried out every 4 years of the trailer use

(1) - post-warranty service

Table 5.2 Inspection schedule

Description of activities	A	B	C	D	E	F	Page
Checking air pressure in tyres	•						5.7
Draining water from air tank	•						5.8
Inspection of connection plugs and sockets	•						5.9
Inspection of shields	•						5.10
Inspection of trailer prior to moving off	•						5.11
Air pressure measurement, inspection of tyres and wheels		•					5.12
Cleaning the air filters			•				5.13
Checking brake shoe linings for wear				•			5.14
Checking wheel axle bearings for slackness				•			5.15
Inspection of mechanical brakes				•			5.16
Cleaning the drain valve				•			5.17
Inspection of parking brake cable tension					•		5.18
Inspection of hydraulic system					•		5.20
Inspection of pneumatic system					•		5.21
Lubrication	See table: <i>Trailer lubrication schedule</i>						5.22
Inspection of nut and bolt connections	See section: Inspection of nut and bolt connections						5.27
Replacement of hydraulic conduits						•	5.30

Table 5.3 Adjustment parameters and settings

Description	Value	Remarks
Brake system		
Cylinder rod stroke in pneumatic systems	25 - 45 mm	
Minimum thickness of brake linings	5 mm	
Angle between expander axle and fork	90°	With depressed brake pedal

I.3.6.621.01.1.EN

5.3 PREPARING THE TRAILER



DANGER

Ensure that unauthorised persons do not have access to the tractor cab.
 Before using the lifting jack, read the operator's manual of the jack and follow the manufacturer's recommendations. The lifting jack must be stably supported on the ground and trailer components.
 Before performing maintenance work and repairs on raised trailer, make certain that the trailer is properly secured and will not move during work.

- Hitch trailer to tractor.
- Park tractor and trailer on hard level ground. Tractor must be placed to drive forwards.
- Engage the tractor's parking brake.
- Turn off the tractor's engine and remove key from ignition. Close the tractor cab to ensure that unauthorised persons do not have access to the tractor cab.
- Place securing chocks under one trailer wheel. Ensure that the trailer will not move during inspection.
- If it is necessary to raise a trailer wheel during inspection, place chocks on

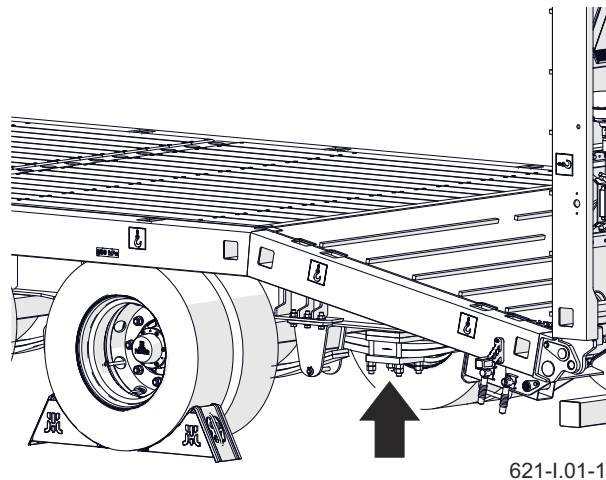

621-I.01-1

Figure 5.1 Recommended trailer support points

the opposite side. Lifting jack should be positioned in the places indicated by the arrow. Remember, lifting jack must be supported on hard and stable ground.

- Lifting jack must be suitable for the weight of trailer.
- In exceptional cases, release the trailer's parking brake, for example when measuring axle bearing slackness. Exercise particular caution in such situations.

I.3.6.621.03.1.EN

5.4 CHECKING AIR PRESSURE IN TYRES

- Visually inspect if the tyres are properly inflated.
- If you think that air pressure in tyres is too low, check air pressure using a manometer. If necessary, inflate the tyre up to the recommended pressure.



ATTENTION

Wrong air pressure in the trailer tyres may lead to permanent damage of tyres resulting from tyre material delamination.

Wrong air pressure in tyres also accelerates the wear of tyres.

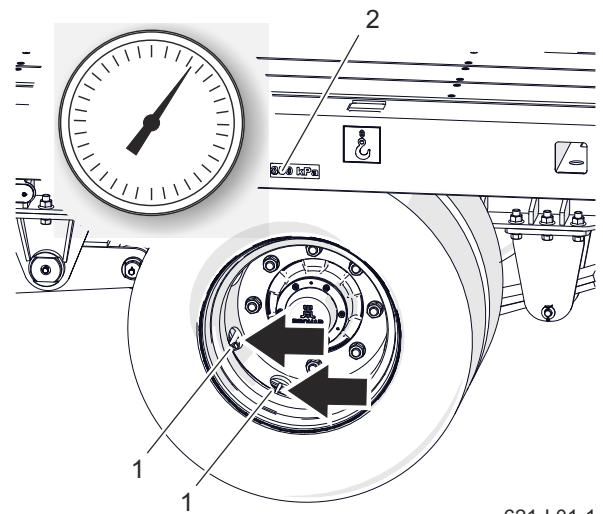

Figure 5.2 Trailer wheel

(1) valve

(2) information decal

TIP

Tyre pressure value is specified on the information decal placed on the trailer frame ridge.

I.3.1.526.04.1.EN

5.5 DRAINING WATER FROM AIR TANK

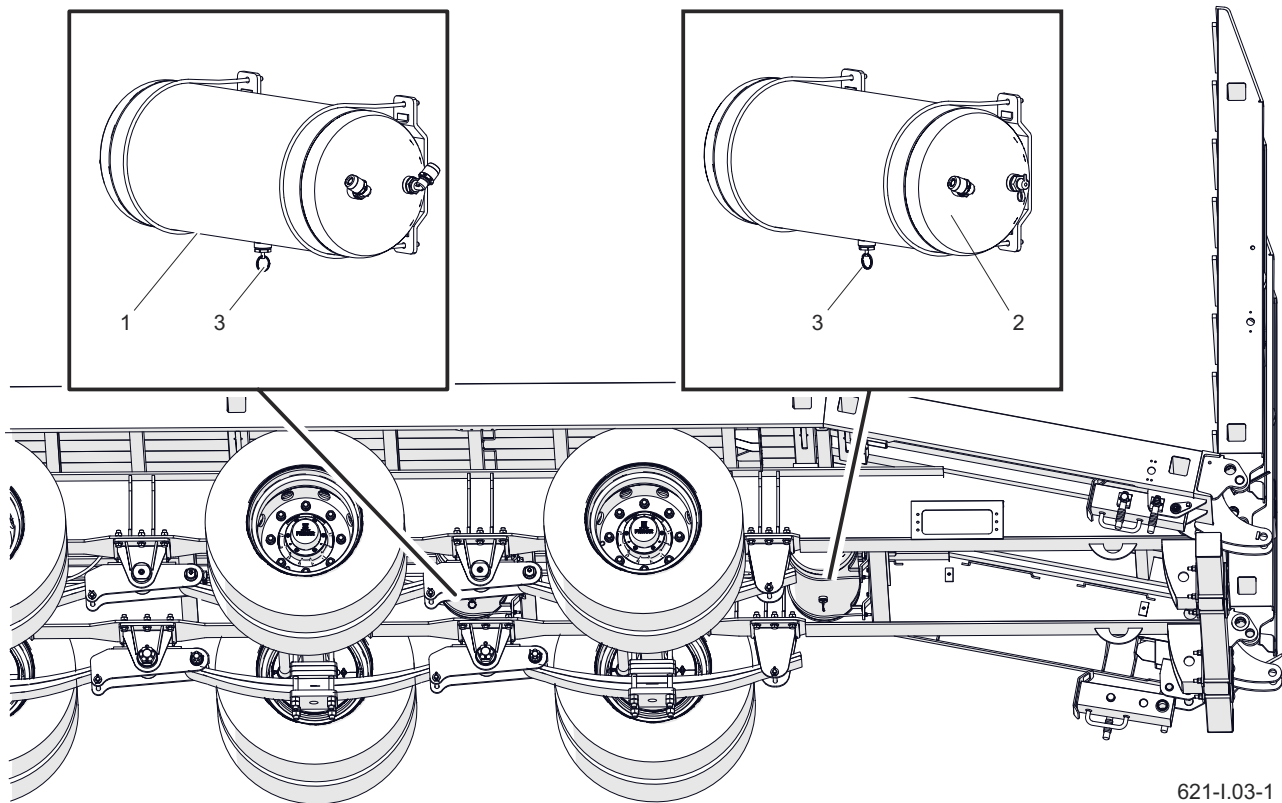

Figure 5.3 Air tank
 (1) front air tank (2) rear air tank (3) drain valve

- Press drain valve stem (1) located in the lower part of tank (2).

The compressed air in the tank causes the removal of water to the exterior.

- After releasing the valve stem, the

valve should automatically close and stop airflow from the tank.

- If the valve stem does not return to its position, wait until the tank is empty. Then, screw out and clean or replace the valve.

I.3.1.526.05.1.EN

5.6 INSPECTION OF CONNECTION PLUGS AND SOCKETS

Damaged connection body or socket body should be replaced. In the event of damage to cover or seal, change these elements for new reliable elements. Contact of pneumatic connection seals with oils, grease, petrol etc. may cause damage and accelerate ageing process.

If the trailer is unhitched from the tractor, connections should be protected by covers or placed in their designated sockets. Before the winter, it is recommended to preserve the seal with special preparations (e.g. silicon grease for rubber elements). Each time before hitching the machine, inspect technical condition and cleanness of connections and sockets in truck tractor. If necessary, clean or repair tractor sockets.

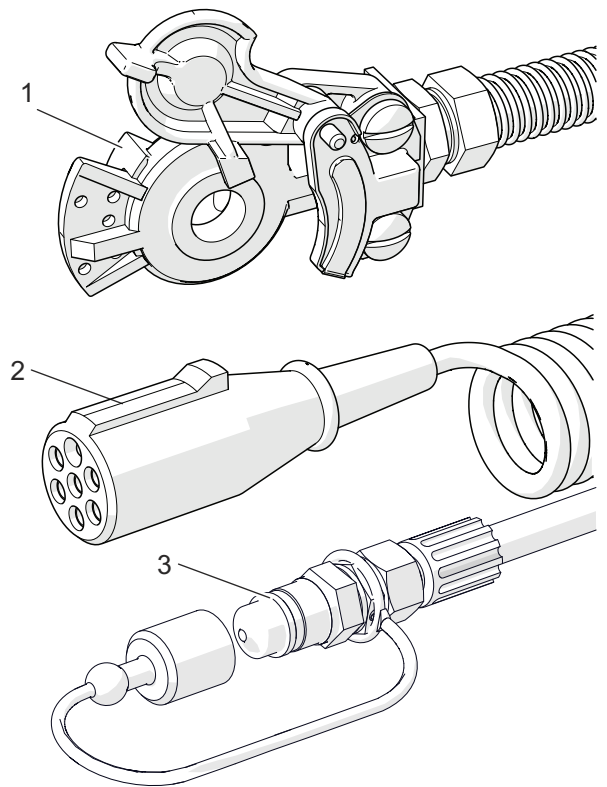

621-H.01-1

Figure 5.4 Trailer connections
 (1) pneumatic plug
 (2) electrical plug
 (3) hydraulic plug

I.3.6.209.02.1.EN

5.7 INSPECTION OF SHIELDS

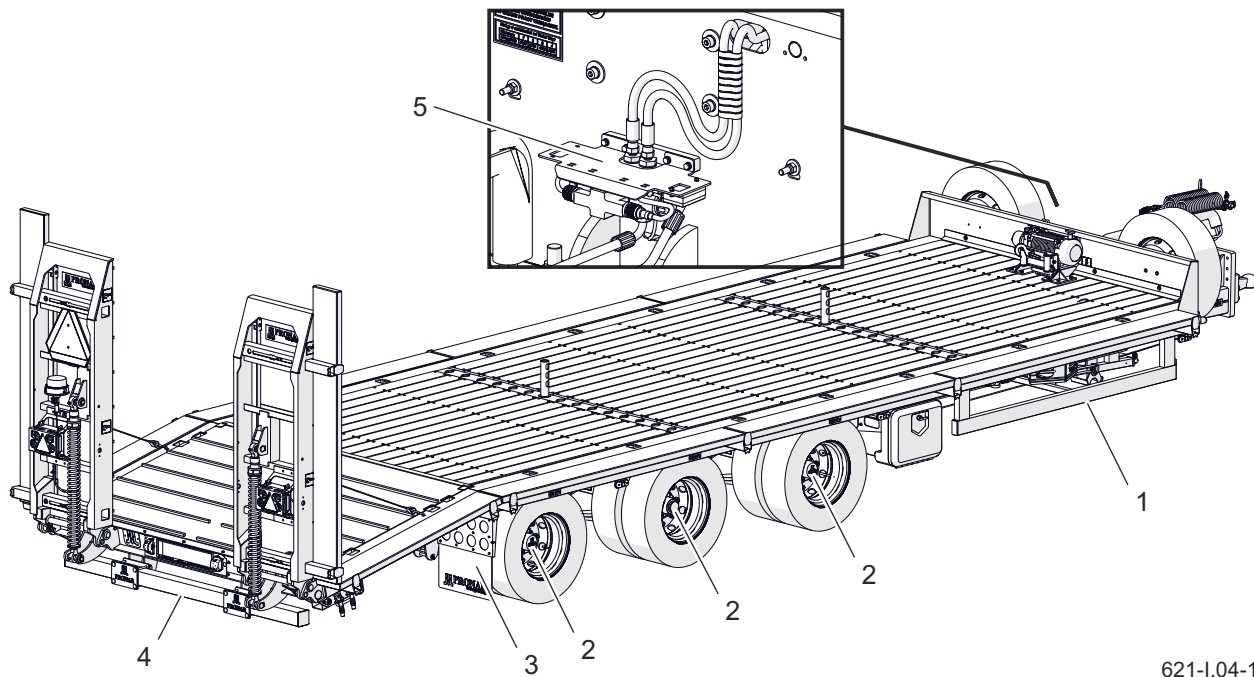

621-I.04-1

Figure 5.5 Trailer shields

(1) side shield

(2) axle cap

(3) mud flap

(4) rear beam

(5) winch valve shield (option)

Shields protect the trailer user's health and life and the machine subassemblies against damage. Therefore, their technical condition must be checked before using the trailer. Any damaged or lost components must be repaired or replaced.

- Check completeness of protective



DANGER

Do NOT use the trailer with damaged or incomplete shields.

shields.

- Check if the shields are properly mounted. Check if the side under-run protection devices and the rear beam are in good technical condition, check condition of mud flaps
- Check if wheel caps are complete.
- If necessary, tighten the bolt connections fixing the shields.

I.3.6.621.07.1.EN

5.8 INSPECTION OF TRAILER PRIOR TO MOVING OFF

- Before hitching the trailer to tractor, make certain that electrical leads and hydraulic and pneumatic conduits are not damaged.
- Check completeness and technical condition of trailer lights.
- Check if all lights and reflectors are clean.
- Make certain that the tractor is equipped with a warning reflective triangle.
- Check if the brake cylinder vent holes are not blocked with impurities and that there is no water or ice inside the brake cylinder. Check if the brake cylinder is correctly installed.

Clean the cylinder, if needed.

In winter, it may be necessary to defrost the cylinder and drain water through unblocked vent holes. Replace damaged cylinder with a new one. When

installing the brake cylinder, maintain its original position with regard to bracket.

- When moving off check if the main brake system operates correctly. Please note that the proper air pressure level in the trailer's air tank is required to ensure proper operation of the pneumatic system.

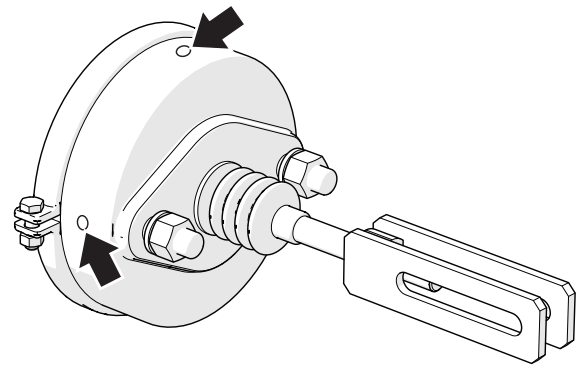

526-1.05-1

Figure 5.6 Brake cylinder

- Correct operation of other systems should be checked regularly during operation of the trailer.



DANGER

Do NOT use the trailer with out of order lighting system or brake system.
Do not use out of order trailer until it is repaired.

I.3.6.209.03.1.EN

5.9 AIR PRESSURE MEASUREMENT, INSPECTION OF TYRES AND WHEELS

During air pressure measurement the trailer must be unloaded. Checking should be done before travelling when tyres are not heated, or after an extended period of trailer parking.

SCOPE OF ACTIVITIES

- Connect a manometer to tyre valve.
- Check air pressure.
- If necessary, inflate the tyre up to the recommended pressure.

Required tyre pressure values are specified on the information decal (2) placed on the frame.

- Check tyre tread depth.
- Check tyre side wall.
- Check tyre for mechanical defects such as loss, cut, deformation or bulging.
- Check that tyre is correctly installed on rim.
- Check tyre age.

While checking pressure, pay attention to technical condition of wheels and tyres. Look carefully at tyre sides and check the condition of tread. In case of mechanical damage consult the nearest tyre service and check whether the tyre defect requires

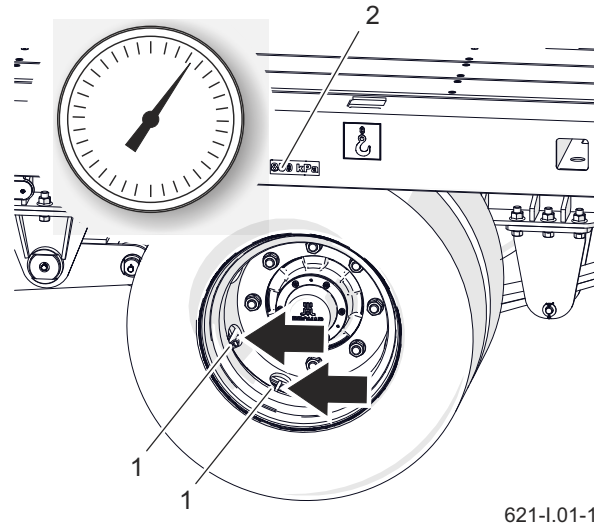

621-I.01-1

Figure 5.7 Trailer wheel

- (1) valve
(2) information decal

tyre replacement. Wheels should be inspected with regard to distortion, breaking of material, breaking of welds, corrosion, especially in the area of welds and contact with tyre.

TIP

If the trailer is used intensively, air pressure in tyres should be checked more frequently.



ATTENTION

Wrong air pressure in the trailer tyres may lead to permanent damage of tyres resulting from tyre material delamination.
Wrong air pressure in tyres also accelerates the wear of tyres.

I.3.6.621.09.1.EN

5.10 CLEANING THE AIR FILTERS

SCOPE OF ACTIVITIES

- Reduce pressure in supply conduit.

Pressure in conduit can be reduced by pressing the head of the pneumatic connection until resistance is felt.

- Remove securing slide (1).
- Hold the filter cover (2).
- Hold the filter cover (2) with the other hand. After removing slide lock, the cover is pushed off by the spring located in the filter housing.
- The filter element and the filter body

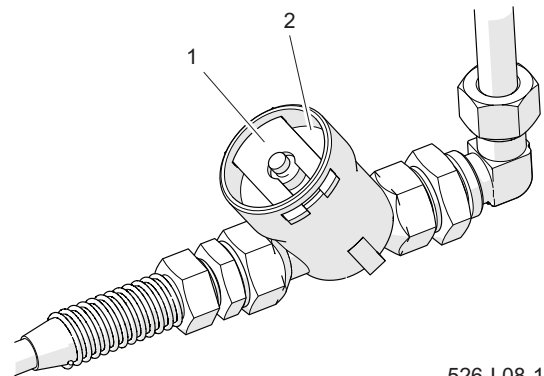

526-I.08-1

Figure 5.8 Air filter
(1) filter slide gate (2) cover

should be carefully cleaned and blown through with compressed air. Assembly should be done in reverse order.

I.3.6.621.10.EN

5.11 CHECKING BRAKE SHOE LININGS FOR WEAR

- Find the inspection opening (depending on the axle version, the inspection opening may be located elsewhere than in the place indicated in the figure; however, it is always located on the brake shield disc).
- Remove the upper plug and lower plug and check the brake shoe lining thickness.
- Brake shoes must be replaced when the lining thickness is less than 5 mm.
- Check other brake shoe linings for wear.

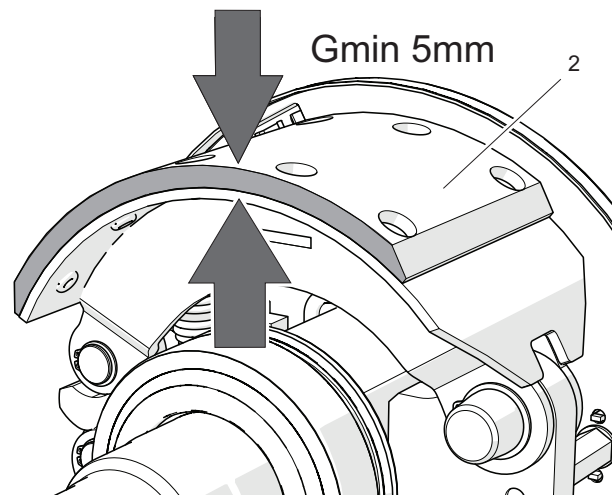
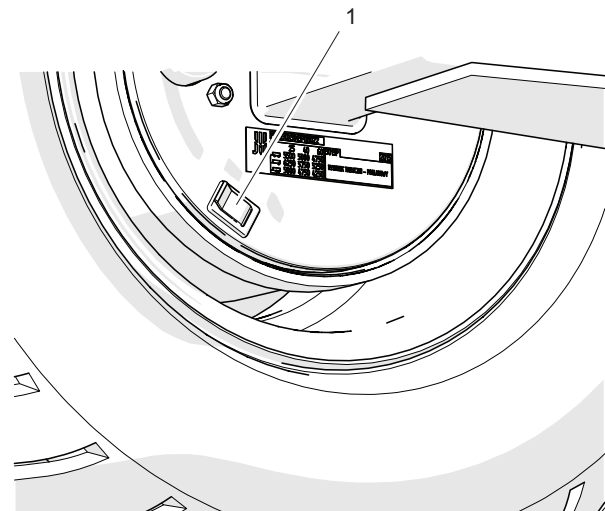

526-I.09-1

Figure 5.9 Checking thickness of brake shoe linings

(1) plug

(2) brake shoe lining

I.3.1.526.11.1.EN

5.12 CHECKING WHEEL AXLE BEARINGS FOR SLACKNESS

- Raise the wheel using a lifting jack.
- Turn the wheel slowly in both directions. Check that movement is smooth and that the wheel rotates without excessive resistance and jamming.
- Turn the wheel so that it rotates very quickly, check that the bearing does not make any unusual sounds.
- Moving the wheel try to detect slackness.
- Repeat the procedure for each wheel individually, remembering that the jack must be on the side opposite to the chocks.
- If slackness is felt, adjust bearings. Unusual sounds coming from bearing may be symptoms of excessive wear, dirt or damage. In such an event the bearing, together with sealing ring, should be replaced with new parts, or cleaned and greased again. During inspection of bearings, ensure that possibly detected slackness comes



526-I.10-1

Figure 5.10 Checking slackness

TIP

If hub cover is damaged or missing, contamination and dampness enter the hub, which causes significantly faster wear of bearings and hub seals. Life of bearings is dependent on working conditions of the trailer, loading, speed of travel and lubrication conditions.

from the bearing and not from the suspension system (e.g. slackness of leaf spring pins etc.).

- Check technical condition of hub cover, if necessary replace it with a new one.

I.3.1.526.12.1.EN

5.13 INSPECTION OF MECHANICAL BRAKES

TIP

Check technical condition of brakes:

- according to the inspection schedule,
- before the period of intensive use.
- after repair of braking system.
- in case of uneven trailer wheels braking.

If the brake is correctly adjusted, the brake cylinder rod stroke (X-Y), figure 5.11, should be within the range specified in table (5.3) and it depends on the cylinder type. At full braking, the optimum angle between the expander lever and the cylinder rod should be about 90°. This setting ensures the best possible braking force. The inspection of brakes consists in measuring this angle and the brake cylinder rod stroke for each wheel.

SCOPE OF ACTIVITIES

- Measure the X distance when the tractor brake pedal is released.
- Measure the Y distance when the tractor brake pedal is depressed.
- Calculate the difference between the

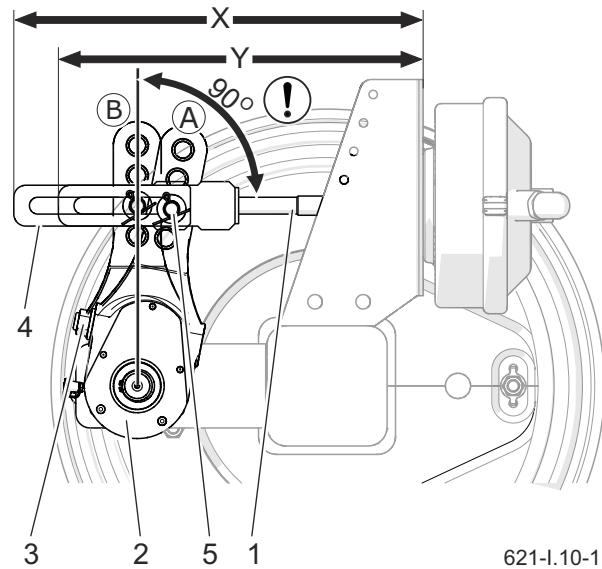

Figure 5.11 Inspection of brake

- (1) cylinder piston rod (2) expander arm
 (3) adjusting bolt (4) cylinder fork
 (5) pin position
 (A) position of arm at brake release position
 (B) position of arm at braking position

distances (X-Y) (cylinder rod stroke).

- Check the angle between the cylinder rod axis and the expander lever.
- If the expander arm angle (2) and the cylinder rod stroke are outside the range specified in table (5.3), adjust the brake.

I.3.6.621.13.1.EN

5.14 CLEANING THE DRAIN VALVE

SCOPE OF MAINTENANCE ACTIVITIES

- Completely reduce pressure in air tank (2).

Reduction of pressure in tank is achieved by tilting the drain valve stem.

- Undo nut (1).
- Clean the valve, blow it with compressed air.
- Replace the seal.
- Screw in valve, fill tank with air and check tank tightness.

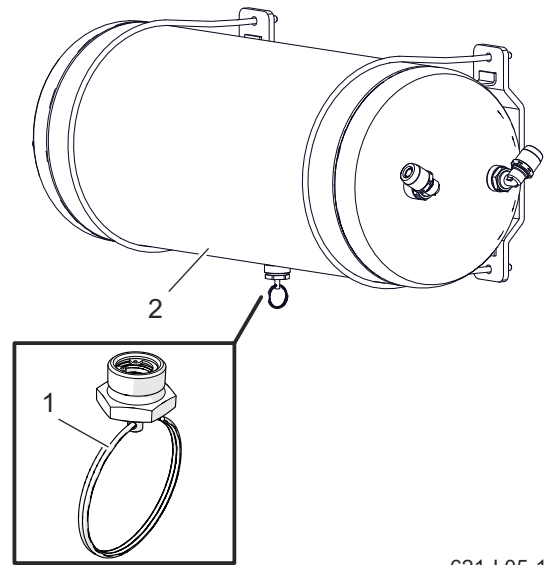

621-I.05-1

Figure 5.12 Air tank
(1) drain valve (2) tank

I.3.6.621.14.1.EN

5.15 INSPECTION OF PARKING BRAKE CABLE TENSION

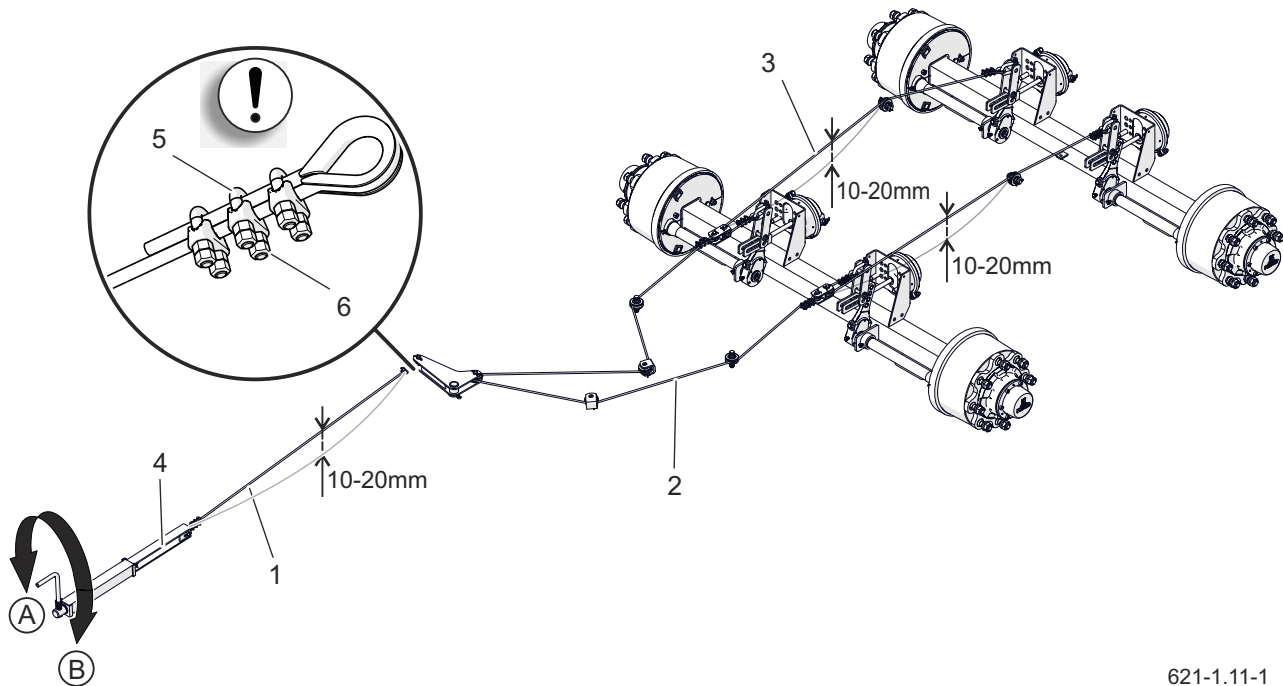

621-1.11-1

Figure 5.13 Inspection of cable tension

(1) cable I

(2) cable II

(3) cable III

(4) brake mechanism

(5) U-shaped clamp

(6) clamp nut

INSPECTION OF TENSION

Parking brake should be checked after checking the mechanical brake of the axle.

- Hitch trailer to tractor. Park trailer and tractor on a level surface.
- Place securing chocks under one trailer wheel.
- Turn the brake mechanism crank (4) in direction (B) to engage the parking brake - figure (5.13).
- Check tension of cables.
- When the brake mechanism bolt is maximally unscrewed, the cable should be loose and hanging by approximately 10 to 20 mm.



DANGER

Do not use the trailer when the brake system is out of order.
Do not use out of order trailer until it is repaired.

ADJUSTMENT OF CABLE TENSION

- Unscrew the brake mechanism bolt maximally (4) by turning the crank in direction (A).
- Loosen nuts (6) of U-bolt clamps (5) on handbrake cable (1).
- Tighten cable (1) and tighten nuts (6) of the clamps
- Engage the parking brake and release it. Check (approximate) cable

slackness. When the working brake and parking brake are fully released, the cable should be loose and hanging by approximately 10-20 mm. The axle expander levers should be

in their rest position.

Should it be necessary to replace the brake cable, follow the instructions in section (6.2) *Replacement of parking brake cable*.

I.3.6.621.15.1.EN

5.16 INSPECTION OF HYDRAULIC SYSTEM

SCOPE OF ACTIVITIES

- Hitch trailer to tractor.
- Immobilise tractor and trailer with parking brake.
- Clean conduit connections, hydraulic cylinders and connectors.
- Raise and lower the parking stand several times (applies to the hydraulic system of the support).
- Unlock the ramps, remove the transport straps. Raise and lower the ramps several times (applies to the hydraulic system of the ramps).
- Unwind the winch rope, start the winch. Wind the rope onto the drum (applies to the hydraulic system of the winch).
- Turn off the tractor engine.
- Check all hydraulic systems for tightness.

ELIMINATION OF LEAKS

If leaks appear at conduit connections then tighten the connections using the specified torque and recheck the connections. If the problem still exists, replace the leaky component.

If oil is found on hydraulic cylinder body, check origin of leak. Inspect seals when hydraulic cylinder is completely extended. Minimum leaks are permissible with symptoms of "sweating", however in the event of noticing leaks in the form of "droplets" stop using the trailer until faults are remedied. Do NOT use the trailer if any of the hydraulic systems is damaged, until the fault is removed.

I.3.6.621.14.1.EN

5.17 INSPECTION OF PNEUMATIC SYSTEM

SCOPE OF ACTIVITIES

- Start tractor in order to supplement air in trailer brake system tank.
- Turn off the tractor engine.
- Check system components by releasing brake pedal in tractor.
- Give particular attention to conduit connections and brake cylinders.
- Repeat system check with depressed truck tractor brake pedal.

ELIMINATION OF LEAKS

In the event of the appearance of leaks, compressed air will escape at the places of damage, with a characteristic hiss. Lack of system tightness may be detected by covering elements to be checked with washing fluid or other foaming preparations, which will not react aggressively with the system components. Damaged components should be replaced or repaired. If leaks appear at connections then tighten the connections. If air continues to escape, replace connection components or seals with new ones.

I.3.6.621.17.1.EN

5.18 LUBRICATION

- Trailer lubrication should be performed with the aid of a manually or foot operated grease gun, filled with recommended grease. Before commencing work insofar as is possible remove old grease and other contamination. After completed lubrication, wipe off excess grease.
- Parts to be lubricated with machine oil should be wiped with dry clean cloth. Apply oil to their surfaces using a brush or oil can. Wipe off excess oil.
- Change of grease in hub bearings should be made at specialised service points, equipped with the appropriate tools. In order to conduct this lubrication, the complete hub should be disassembled as well as bearings and individual sealing rings should be removed. After careful washing and inspection, mount lubricated elements. If necessary, bearing and seals should be replaced with new ones.
- Empty grease or oil containers should be disposed of according to the recommendations of the lubricant Manufacturer.

Table 5.4 Lubricants

Item	Symbol	Description
1	A	machine general-purpose grease (lithium, calcium grease),
2	B	permanent grease for heavily loaded elements with addition of MoS ₂ or graphite
3	C	anticorrosion preparation in aerosol
4	D	ordinary machine oil, silicon grease in aerosol

TIP

Lubrication frequency (see table *Trailer lubrication schedule*):

D - working day (8 hours of trailer use)

M - month

Table 5.5 Trailer lubrication schedule

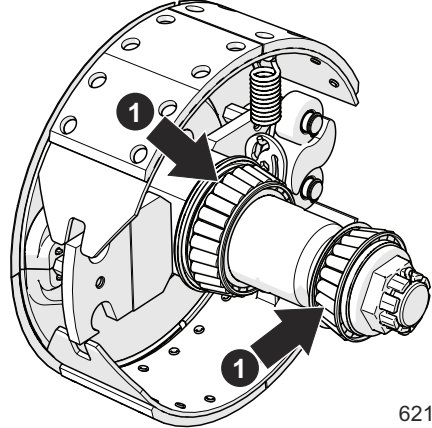
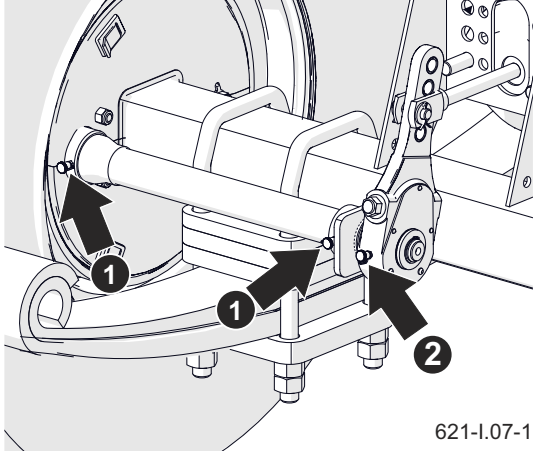
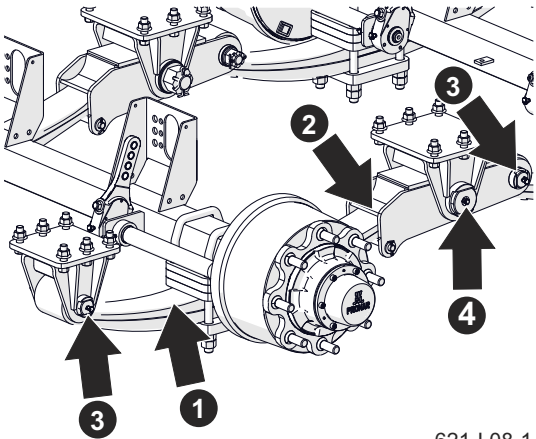
Name	Number of lubrication points	Type of grease	Frequency	
Hub bearings (1) (2 bearings in each hub)	12	A	24M	 <p>621-l.06-1</p>
Expander shaft sleeves (1)	12	A	3M	 <p>621-l.07-1</p>
Expander arm (2)	6	A	3M	
Leaf springs (1)	6	C	3M	 <p>621-l.08-1</p>
Leaf spring sliding surface (2)	6	B	1M	
Leaf spring pin (3)	6	B	1M	
Rocker arm pin (4)	4	B	1M	

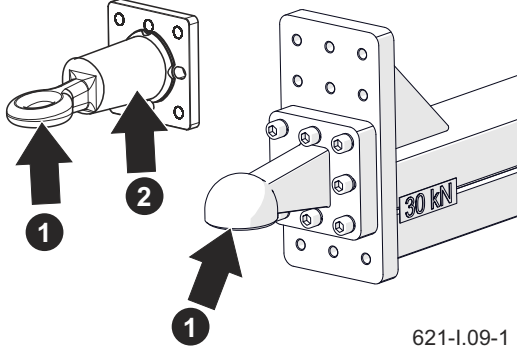
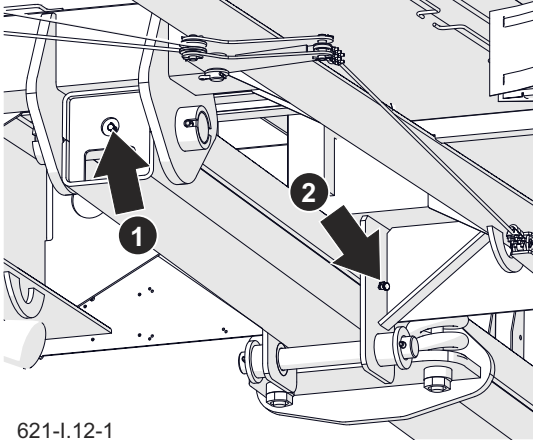
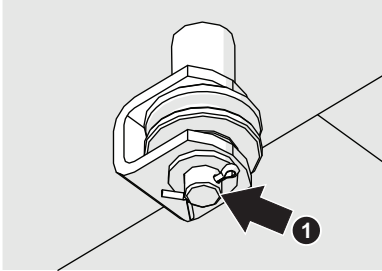
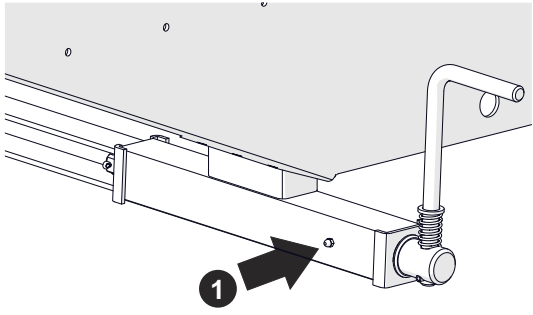
Name	Number of lubrication points	Type of grease	Frequency	
Drawbar hitching eye (1)	1	B	14D	 <p>621-I.09-1</p>
Rotary drawbar (2)	1	B	1M	
Drawbar pin (1)	2	B	3M	 <p>621-I.12-1</p>
Drawbar side surface (2)	2	B	3M	
Parking brake cables guide wheel axle (1)	7	A	6M	 <p>589-I.06-1</p>
Handbrake mechanism (1)	1	A	6M	 <p>621-I.13-1</p>

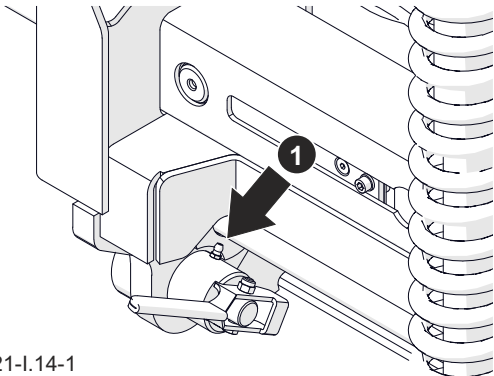
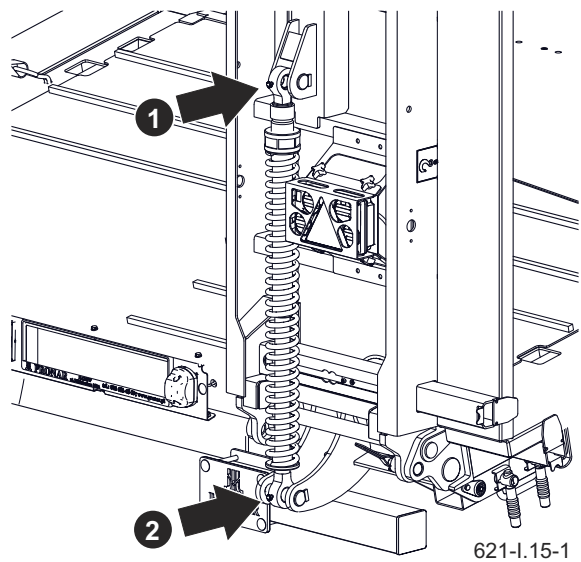
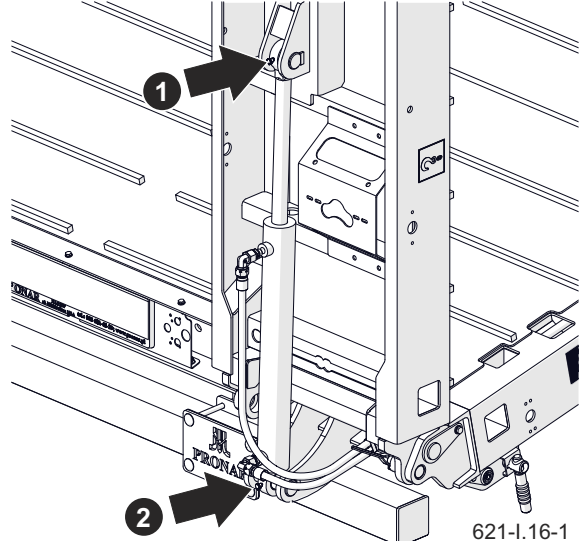
Name	Number of lubrication points	Type of grease	Frequency	
Pin of ramp interlock lever (1)	1	A	14D	 <p>621-I.14-1</p>
Upper pin securing ramp spring (1)	2	B	3M	 <p>621-I.15-1</p>
Lower pin securing ramp spring (2)	2	A	3M	
Upper bearing of ramp cylinder (1)	2	A	3M	 <p>621-I.16-1</p>
Lower bearing of ramp cylinder (2)	2	A	6M	

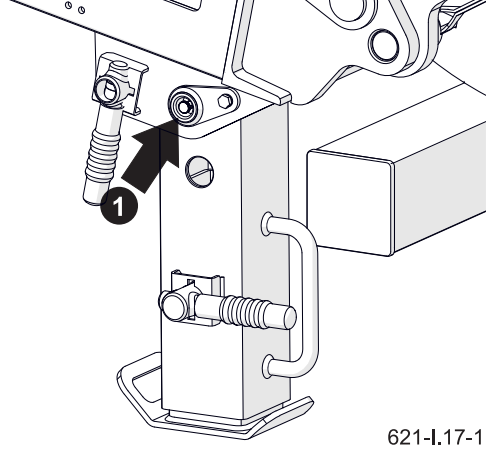
Name	Number of lubrication points	Type of grease	Frequency	
Rear support pin (1)	2	A	3M	 <p>621-I.17-1</p>

I.3.6.621.18.1.EN

5.19 INSPECTION OF NUT AND BOLT CONNECTIONS

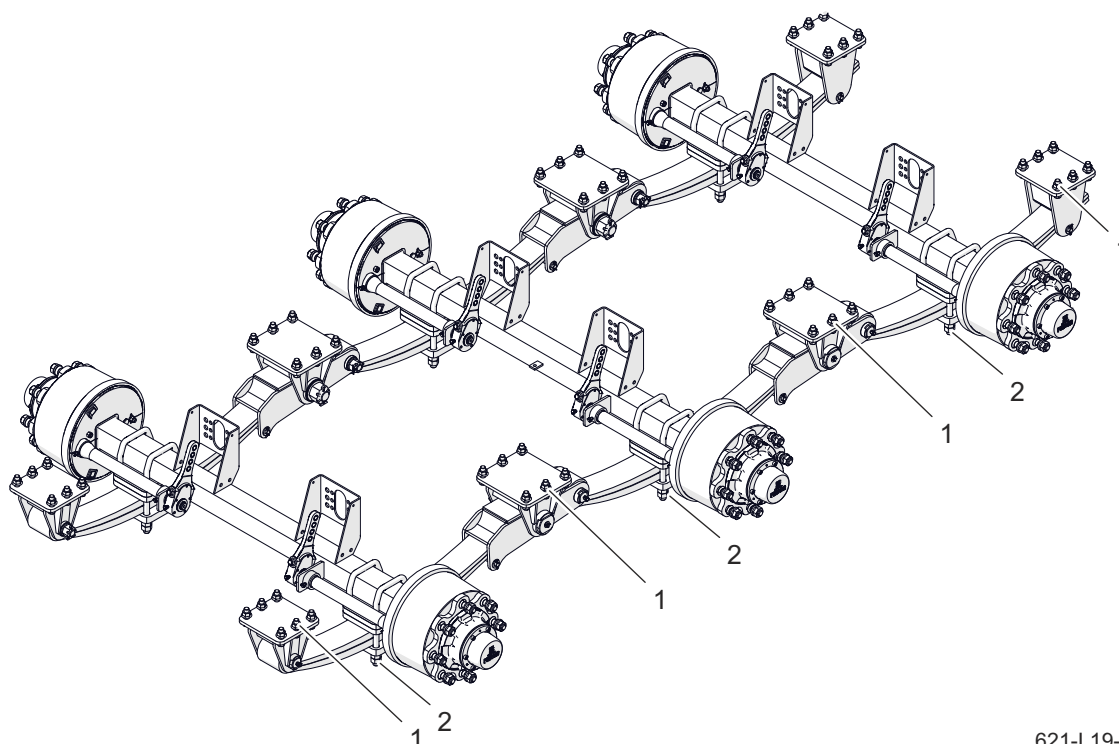

621-I.19-1

Figure 5.14 Inspection of suspension connections
 (1) suspension mounting (2) axle mounting

TIGHTENING TORQUE FOR NUT AND BOLT CONNECTIONS

Unless other tightening parameters are given, during maintenance repair work apply appropriate torque to tighten nut and bolt connections. Recommended tightening torque values for the most frequently used bolt and nut connections are given in table (5.6). Given values apply to non-lubricated steel bolts.

Hydraulic conduits should be tightened using torque of 50–70Nm.

Tightening torque should be checked using a torque wrench. During daily inspection

of the trailer, pay attention to loosen connections and tighten them, if necessary. Lost components must be replaced with new ones.

Tightening of the suspension mounting connections (1) and the axle fastening with U bolts (2) should be checked after the first travel with load and then before intensive work or once every 6 months of the machine use.

M20x1.5 wheel nuts should be tightened gradually and diagonally until the wheels are completely set on the axle drums (in several stages, until the required tightening

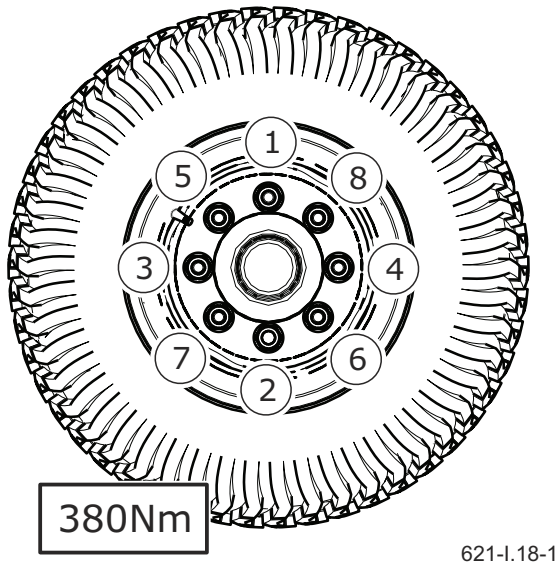

Figure 5.15 Sequence of nut tightening

torque of $M=380\text{Nm}$ is obtained) using a torque wrench. For the recommended nut tightening sequence and tightening torque value see figure *Sequence of nut tightening*.

Wheel nuts must not be tightened with impact wrench because of danger of exceeding permissible tightening torque, the consequence of which may be breaking the connection thread or breaking off the hub pin.

Wheel nuts should be tightened:

- after the first use of the trailer (one-time inspection),
- every 2–3 hours of the trailer travel during the first month of the trailer use,
- every 30 hours of trailer travel.

The above activities should be repeated if a wheel has been removed from the wheel

Table 5.6 Tightening torque values

Thread	Tightening torque	
	8.8	10.9
M8	25	36
M10	49	72
M12	85	125
M14	135	200
M16	210	310
M20	425	610
M24	730	1,050
M27	1,150	1,650
M30	1,450	2,100

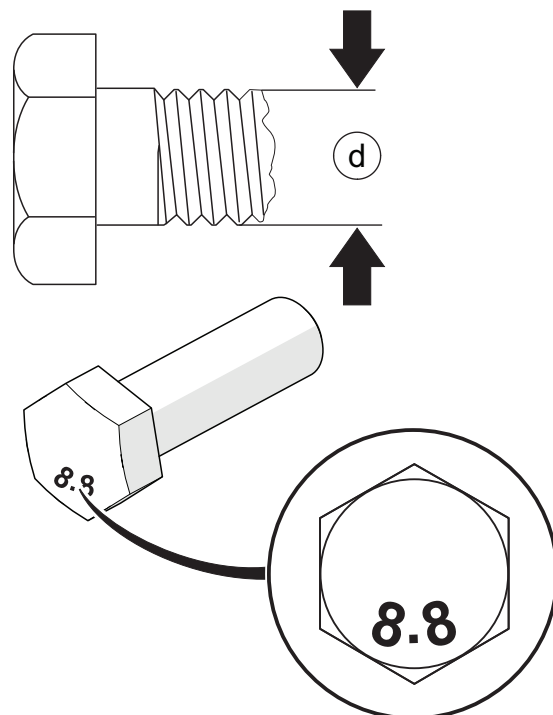

Figure 5.16 Bolt with metric thread.

axle.

Drawbar eye tightness should be checked simultaneously with wheel nut tightness checking. Tightening torque for M20x80

bolts should be 395Nm. Nuts should be tightened gradually diagonally, using torque spanner.

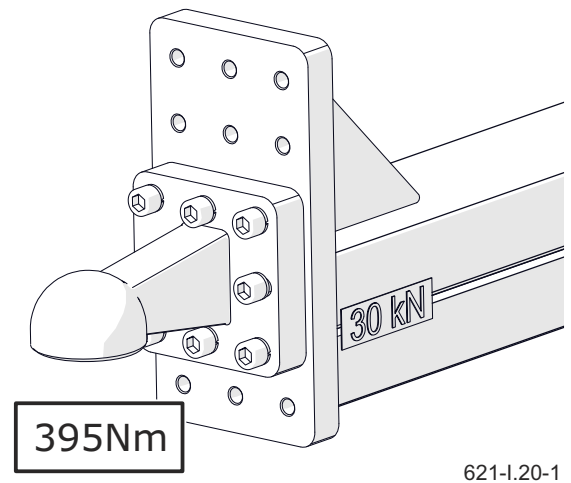

Figure 5.17 Drawbar eye tightening

I.3.6.621.19.1.EN

5.20 REPLACEMENT OF HYDRAULIC CONDUITS

Rubber hydraulic conduits must be replaced every 4 years regardless of their technical condition. This should be done in specialised workshops.

I.3.1.526.20.1.EN

SECTION 6

MAINTENANCE

6.1 WHEEL MOUNTING AND DISMOUNTING

WHEEL DISMOUNTING

- Before lifting the wheel to be dismounted, loosen wheel nuts according to the sequence shown in the figure.
- Place the wheel chocks under the wheel opposite to the wheel to be dismounted.
- Place the lifting jack under the axle backing, between the U bolts.
- Raise the trailer to a sufficient height so that the wheel to be replaced does not touch the ground.
- The lifting jack should have sufficient lifting capacity and should be technically reliable.
- The lifting jack must be positioned on a level and hard surface so as to prevent sinking into the ground or re-locating the jack during lifting.
- If necessary, use proper backing plates in order to reduce unit pressure of the jack's base on the ground and prevent its sinking into the ground.
- Dismount the wheel.

WHEEL MOUNTING

- Using a wire brush, remove contaminations from axle pins and nuts. If

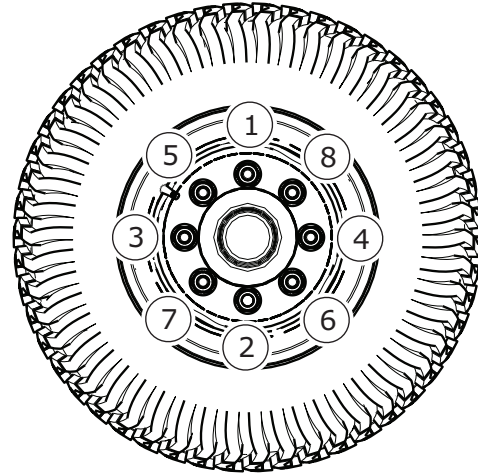

D.6-1

Figure 6.1 Sequence of nut tightening



DANGER

Before commencing work, the user must read the instructions for lifting jack and adhere to the manufacturer's instructions. The lifting jack must be stably supported on the ground and absorber plate. Ensure that trailer shall not move when dismounting wheels.

necessary, degrease the thread.

Do not grease the thread of nuts and pins.

- Check technical condition of pins and nuts, if necessary replace.
- Place wheel on hub, tighten nuts so that wheel rim tightly fits the hub.
- Lower the trailer, tighten nuts according to recommended torque and given sequence.

J.3.1.526.01.1.EN

6.2 REPLACING THE PARKING BRAKE CABLE

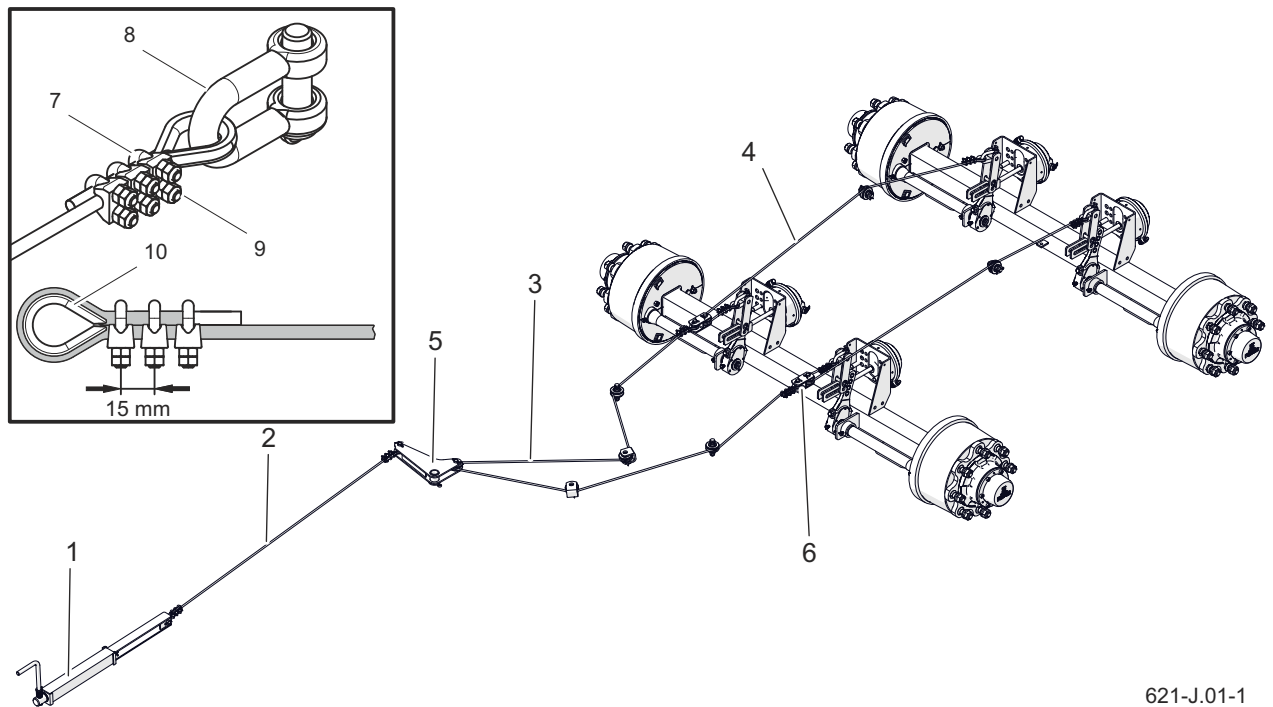

621-J.01-1

Figure 6.2 Replacing the parking brake cable

- | | | |
|---------------------|-------------------|------------------------|
| (1) brake mechanism | (2) brake cable I | (3) brake cable II |
| (4) brake cable III | (5) lever | (6) brake pulley block |
| (7) clamp | (8) shackle | (9) clamp nut |
| | | (10) thimble |

SCOPE OF ACTIVITIES

- Hitch trailer to tractor. Park trailer and tractor on level surface.
- Place securing chocks under one trailer wheel.
- Fully unscrew the bolt of the brake crank mechanism (1) - figure (6.2).
- Loosen nuts (9) of U-shaped clamps (7) on the cable to be replaced.
- Dismantle shackles (8), clamps (6) and remove cable to be replaced.
- Clean the parking brake components.
- Lubricate parking brake crank mechanism (1) and pins of cable guide rollers.
- Install shackle and U-shaped clamps on one end of the cable. Make certain that clamps are correctly installed.
- Attach one end of cable, install shackle pin and secure it with new cotter pins.
- Pass the other end of the cable through guide rollers and attach the other end of the cable in the same way.
- Adjust tension of the cable - section 5.15.
- Tighten the nuts.

- Tighten the crank mechanism cable and then loosen it. If necessary, correct the brake cable tension.

J.3.6.621.03.1.EN

6.3 BRAKES ADJUSTMENT

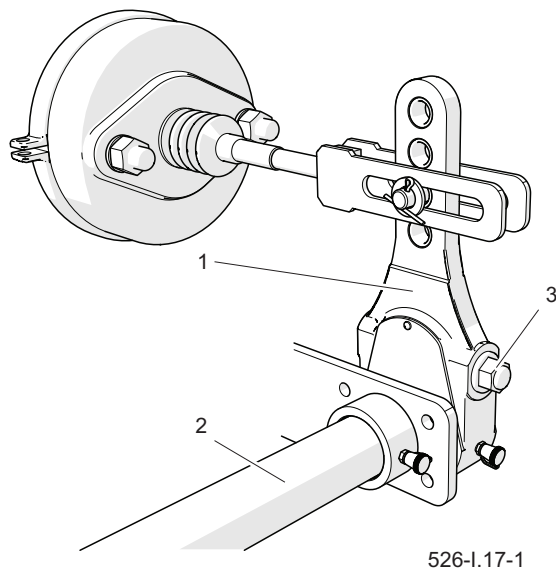

Figure 6.3 Brake adjustment

- (1) expander levers
- (2) expander shaft
- (3) adjusting bolt

- Secure the trailer using additional chocks.
- Release trailer's parking brake.
- Dismantle brake cylinder fork pin.
- Make a line (A) on brake cylinder piston rod (1) - figure (6.4) to indicate the position of the maximum withdrawal of brake cylinder piston rod.
- Press the tractor brake pedal and mark the position of the maximum extension of the brake cylinder piston rod (B) with a line.
- Measure the distance between lines (A) and (B). If the stroke of the brake cylinder piston rod is outside the proper operating range - table (5.3),

adjust the expander lever.

- Remember or mark the original position of pin (6), figure (6.4), in expander lever opening (3).
- Check if the brake cylinder piston rod moves freely and within the whole nominal range.
- Check if the brake cylinder is correctly installed.
- Check if the brake cylinder vent holes

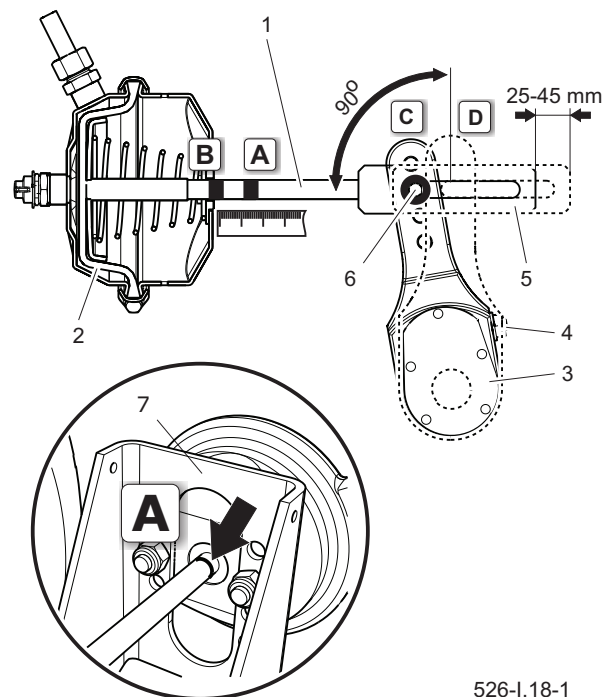

Figure 6.4 Principle of brake adjustment

- (1) piston rod
- (2) membrane
- (3) expander levers
- (4) adjusting bolt
- (5) cylinder fork
- (6) pin position
- (7) cylinder bracket
- (A) mark on the piston rod at brake release position
- (B) mark on the piston rod at braking position
- (C) position of arm at brake release position
- (D) position of arm at full braking position

are not blocked with impurities and that there is no water or ice inside the brake cylinder.

- Clean the brake cylinder. If necessary, defrost the brake cylinder and drain water through the unblocked vent holes. Replace damaged brake cylinder with a new one. When installing the brake cylinder, maintain its original position with regard to bracket (7).
- Rotate adjustment bolt (4) to align the marked expander arm opening with the brake cylinder fork opening.

During adjustment, membrane (2) must rest on the rear wall of the brake cylinder.

- Install the brake cylinder fork pin and washers and secure the pin with cotter pins.
- Rotate adjustment bolt (4) to the right

until one or two clicking sounds are heard in the expander arm regulating mechanism.

- Repeat the adjustment activities for other cylinders.
- Engage the brake.
- Remove previous marks and measure the brake cylinder piston rod stroke again.
- If the brake cylinder piston rod stroke is outside the proper operating range, repeat the adjustment.

CHECKING THE BRAKE OPERATION

- After completed adjustment, perform a trial run.
- Engage the brake several times. Stop the tractor with trailer and check the temperature of brake drums.
- If any of the drums is too hot, correct the brake adjustment and perform a trial run again.

J.3.1.526.04.1.EN

6.4 ADJUSTMENT OF AXLE BEARING SLACKNESS

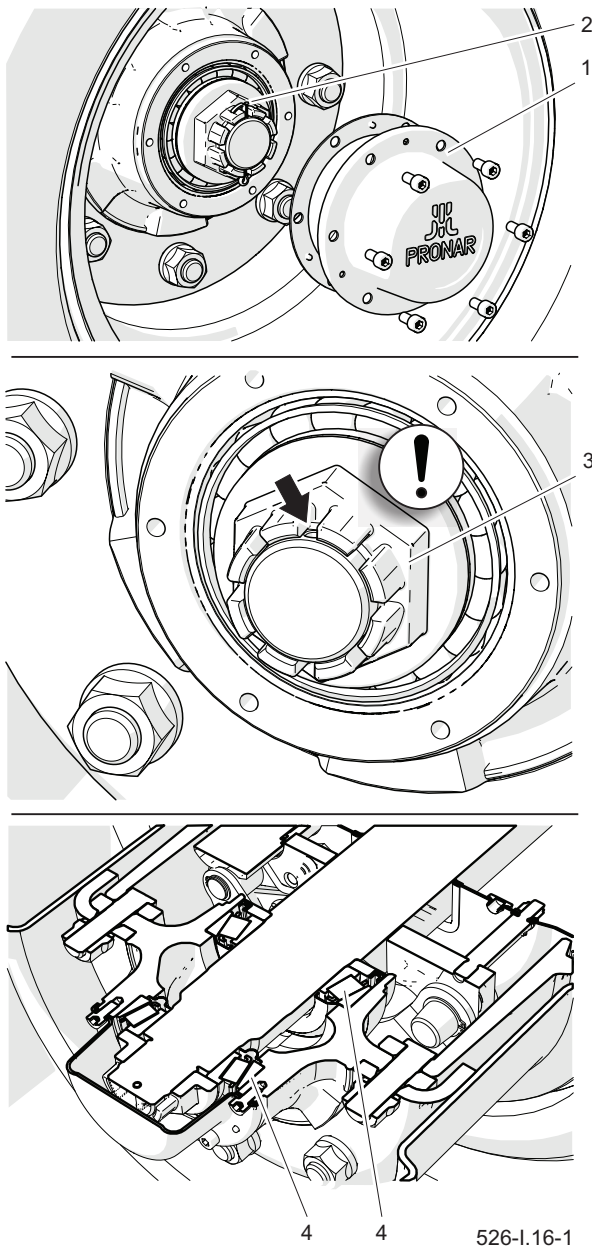

Figure 6.5 Bearing slackness adjustment principle

(1) cap

(2) cotter pin

(3) nut

(4) cone bearing

- Dismantle hub cover (1).
- Take out cotter pin (2) securing castellated nut (3)
- Tighten castellated nut in order to eliminate looseness.

Wheel should rotate with insignificant resistance.

- Undo nut (3) (not less than 1/3 rotation) to align the nearest thread groove with the opening in wheel axle pin (cotter pin opening is indicated by black arrow in the figure). Wheel should rotate without excessive resistance.

The nut must not be excessively tightened. Otherwise, operating conditions of the bearings will deteriorate.

- Secure castellated nut with cotter pin and mount the hub cap (1).
- Delicately tap hub cap with rubber or wooden hammer.



ATTENTION

Adjustment of bearing slackness may only be conducted when the trailer (without load) is hitched to the tractor.

6.5 ADJUSTMENT OF DRAWBAR EYE HEIGHT

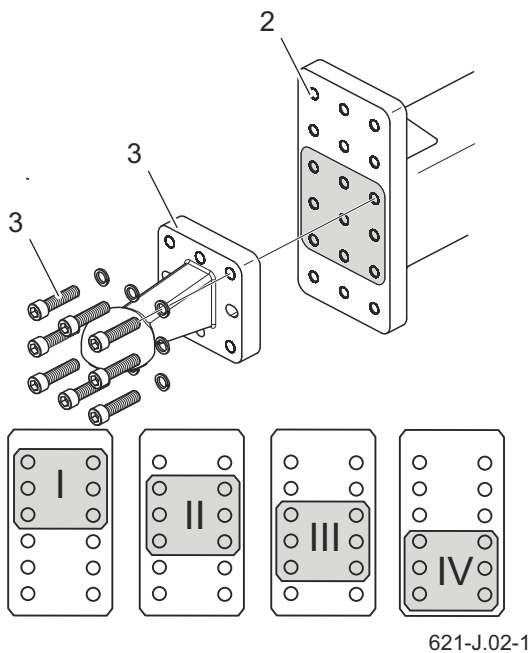

Figure 6.6 Adjustment of drawbar height
 (1) drawbar
 (2) faceplate
 (3) fixing bolt
 Drawbar eye positions: I, II, III, IV

Position of trailer drawbar eye depends on the type of agricultural tractor hitch. If possible, we recommend adjusting the tractor hitch so that the platform of the trailer connected to the tractor is positioned parallel to the ground. If the tractor hitch cannot be adjusted, adjust position of trailer drawbar eye with regard to the drawbar faceplate (2) – Figure (6.6).



ATTENTION

Proper adjustment of the drawbar eye position significantly facilitates trailer hitching. After adjustment, the drawbar should be in a horizontal position. During the adjustment, take special care due to the significant weight of the drawbar and the risk of crushing limbs.

SCOPE OF ACTIVITIES

- Immobilise trailer with parking brake.
- Place chocks under the trailer wheels.
- Unscrew drawbar eye (1) from faceplate (2).
- Set the drawbar eye in its new position and tighten with bolts (3) using appropriate torque.

The faceplate design (2) allows 4 possible drawbar eye positions - Figure (6.6).

Drawbar eye tightening should be checked according to the schedule defined by the Manufacturer as described in section 5.19.

J.3.6.621.01.1.EN

6.6 MAINTENANCE OF ELECTRICAL SYSTEM AND WARNING ELEMENTS



ATTENTION

Do NOT travel with out of order lighting system. Damaged lamp lenses must be replaced immediately before travelling. Lost or damaged reflectors must be replaced.
Before driving off, make certain that all lamps and reflectors are clean.

Work connected with the repair, change or regeneration of electrical system components should be entrusted to specialist establishments, having the appropriate technology and qualifications for this type of work.

The duties of the user include only technical inspection of electrical system and reflectors.

SCOPE OF ACTIVITIES

- Connect trailer to tractor with appropriate connection lead.
- Check if the connection lead is reliable. Check connection sockets in tractor and trailer.
- Check completeness and technical condition of trailer lights.
- Check completeness of all reflectors.
- Check correct mounting of the slow-moving vehicle warning sign holder.
- Before driving on to public road, check that the tractor is equipped with a warning reflective triangle.

TIP

Light-emitting diodes (LED) are used as the source of light. Damaged lights can be replaced only as complete units. It is impossible to repair or regenerate them.

J.3.6.621.01.1.EN

6.7 CONSUMABLES

HYDRAULIC OIL

Always adhere to the principle that the oil in the trailer hydraulic system and in the tractor hydraulic system are of the same type. In the event of application of different types of oil make certain that both hydraulic substances may be mixed together. Application of different oil types may cause damage to trailer or tractor. In a new machine, the hydraulic system is filled with L HL32 Lotos hydraulic oil.

If it is necessary to change hydraulic oil for another oil, check the recommendations of the oil Manufacturer very carefully. If it is recommended to flush the system with the appropriate preparation, then comply with these recommendations. Attention should be given, so that chemical substances used for this purpose do not damage the materials of the hydraulic system. During

normal trailer use change of hydraulic oil is not necessary, but if required, this operation should be entrusted to a specialist service point.

Because of its composition the oil applied is not classified as a dangerous substance, however long-term action on the skin or eyes may cause irritation. In the event of contact of oil with skin wash the place of contact with water and soap. Do NOT apply organic solvents (petrol, kerosene). Contaminated clothing should be changed to prevent access of oil to skin. In the event of contact of oil with eye, rinse with large quantity of water and in the event of the occurrence of irritation consult a doctor. Hydraulic oil in normal conditions is not harmful to the respiratory tract. A hazard only occurs when oil is strongly atomised (oil vapour), or in the case of fire during

Table 6.1 L-HL 32 Lotos oil characteristics

Item	Name	Unit	
1	ISO 3448VG viscosity classification	-	32
2	Kinematic viscosity at 40°C	mm ² /s	28.8 – 35.2
3	ISO 6743/99 quality classification	-	HL
4	DIN 51502 quality classification	-	HL
5	Flash-point	C	230

which toxic compounds may be released. Oil fires should be quenched with the use of carbon dioxide, foam or steam extinguishers. Do not use water to quench oil fires.

LUBRICANTS

For heavily loaded parts it is recommended to apply lithium greases with addition of molybdenum disulphide (MoS_2) or graphite. In the case of less loaded sub-assemblies the application of general purpose machine greases is recommended, which contain anticorrosion additives and have significant resistance to being washed away by water. Aerosol

preparations (silicon greases and anti-corrosive-lubricating substances) should have similar characteristics.

Before using the grease, read its information leaflet. Particularly relevant are safety rules and handling procedures for a given lubricant as well as waste disposal procedure (used containers, contaminated rags etc.). Information leaflet (material safety data sheet) should be kept together with grease.

TIP

Lubrication frequency (see table: Trailer lubrication schedule):

Table 6.2 Lubricants

Item	Symbol	Description
1	A	machine general-purpose grease (lithium, calcium grease),
2	B	Grease for heavily loaded elements with addition of MoS_2 or graphite
3	C	anticorrosion preparation in aerosol
4	D	ordinary machine oil, silicon grease in aerosol

J.3.1.526.05.1.EN

6.8 TROUBLESHOOTING

Table 6.3 Troubleshooting

FAULT	CAUSE	REMEDY
Problem with moving off	Brake system conduits not connected	Connect brake conduits (applies to pneumatic systems)
	Applied parking brake	Release parking brake.
	Damaged pneumatic system connection conduits	Replace.
	Leaking connections	Tighten, replace washers or seal sets, replace conduits.
	Damaged control valve	Check valve, repair or replace.
Noise in axle hubs	Excessive bearing slackness	Check slackness and adjust if needed
	Damaged bearings	Replace bearings
	Damaged hub parts	Replace
Poor reliability of braking system	Insufficient pressure in the system	Check pressure on tractor pressure gauge, wait till compressor fills tank to required pressure. Damaged air compressor in tractor Repair or replace. Damaged brake valve in tractor. Repair or replace. Leaking system conduits or connections. Check system for tightness.
Excessive heating of axle hubs	Incorrect main or parking brake adjustment	Regulate positions of expander arms
	Worn brake linings	Change brake shoes
Incorrect hydraulic system operation	Improper hydraulic oil viscosity	Check oil quality, make sure that the oil in both machines is of the same type. If necessary change oil in tractor or in trailer.

FAULT	CAUSE	REMEDY
Incorrect hydraulic system operation	Insufficient tractor hydraulic pump output, damaged tractor hydraulic pump.	Check tractor hydraulic pump.
	Damaged or contaminated cylinder	Check cylinder piston rod (bending, corrosion), check cylinder for tightness (cylinder piston rod seal), if necessary, repair or replace the cylinder.
	Excessive cylinder loading	Check and reduce cylinder load, if necessary
	Damaged hydraulic conduits	Check and ascertain that hydraulic conduits are tight, not fractured and properly tightened. If necessary, replace or tighten.
Excessive wear of left and right tyre shoulders on both sides.	Too low air pressure in tyres. Excessive speed of travel of loaded trailer on turns. Too fast loss of air due to damaged wheel, valve, puncture, etc.	Check air pressure. Regularly check correctness of air pressure in tyres. Excessive loading of the trailer. Do not exceed the permissible gross weight of the trailer. Reduce speed of travel while driving on turns on hardened surface. Check wheel and valve. Replace damaged parts.
Excessive wear of central part of tyre.	Excessive air pressure in tyres.	Check air pressure. Regularly check correctness of air pressure in tyres.
Excessive wear of left or right tyre shoulder, on one side	Incorrect toe-in. Incorrectly positioned wheel axles.	Damaged leaf spring on one side of the suspension system. Replace leaf springs.
Worn tyre tread.	Damaged suspension system, broken leaf spring. Damaged brake system, blocking of brakes, incorrectly adjusted brake system. Too frequent and violent braking.	Check suspension system for looseness, check leaf springs. Replace damaged or worn elements. Check brake system for malfunctions. Adjust expander lever.

FAULT	CAUSE	REMEDY
Side crack.	Prolonged use of tyre with low air pressure. Excessive loading of the trailer.	Regularly check air pressure in tyres. Check weight of load while loading.
Abrasions on external side edge of tyre.	Too frequent driving over sharp or high obstacles (e.g. curbs).	Control driving technique.
Damaged rim (hardening and cracking near rim), brittleness of tyre.	Incorrect braking technique. Too frequent violent braking. Damaged brake system.	Check brake system. Control braking technique. Damage occurs due to excessive heating of hub which leads to heating of wheel.

J.3.6.621.07.1.EN

SECTION 7

TYRE SYSTEM

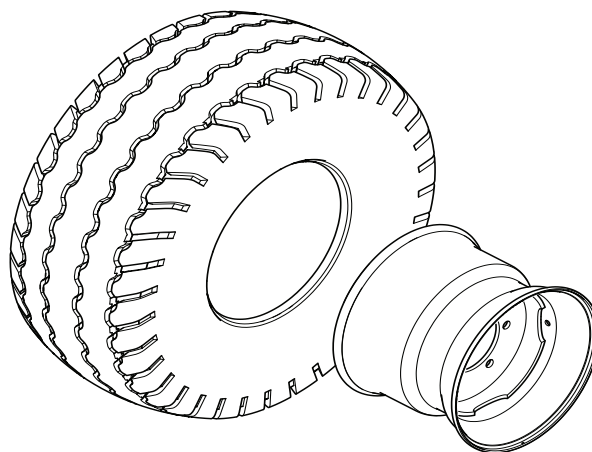

U-K.01-1

Table 7.1 Trailer tyres

Item	Tyre	Minimum load index and speed rating	Wheel rim
1	215/75 R17.5	135/133 J	17.5x6.75
2	235/75 R17,5	143/141 J	17.5x6.75
3	245/75 R17,5	136/134 L	17.5x6.75
4	265/70 R17,5	139/136 M	17.5x6.75

