



PRONAR Sp. z o.o.

17- 210 NAREW, UL. MICKIEWICZA 101A, WOJ. PODLASKIE

tel.:	+48 085 681 63 29	+48 085 681 64 29
	+48 085 681 63 81	+48 085 681 63 82
fax:	+48 085 681 63 83	+48 085 682 71 10

www.pronar.pl

USER MANUAL

ROTARY TEDDER

PRONAR PWP460

TRANSLATION OF ORIGINAL INSTRUCTION

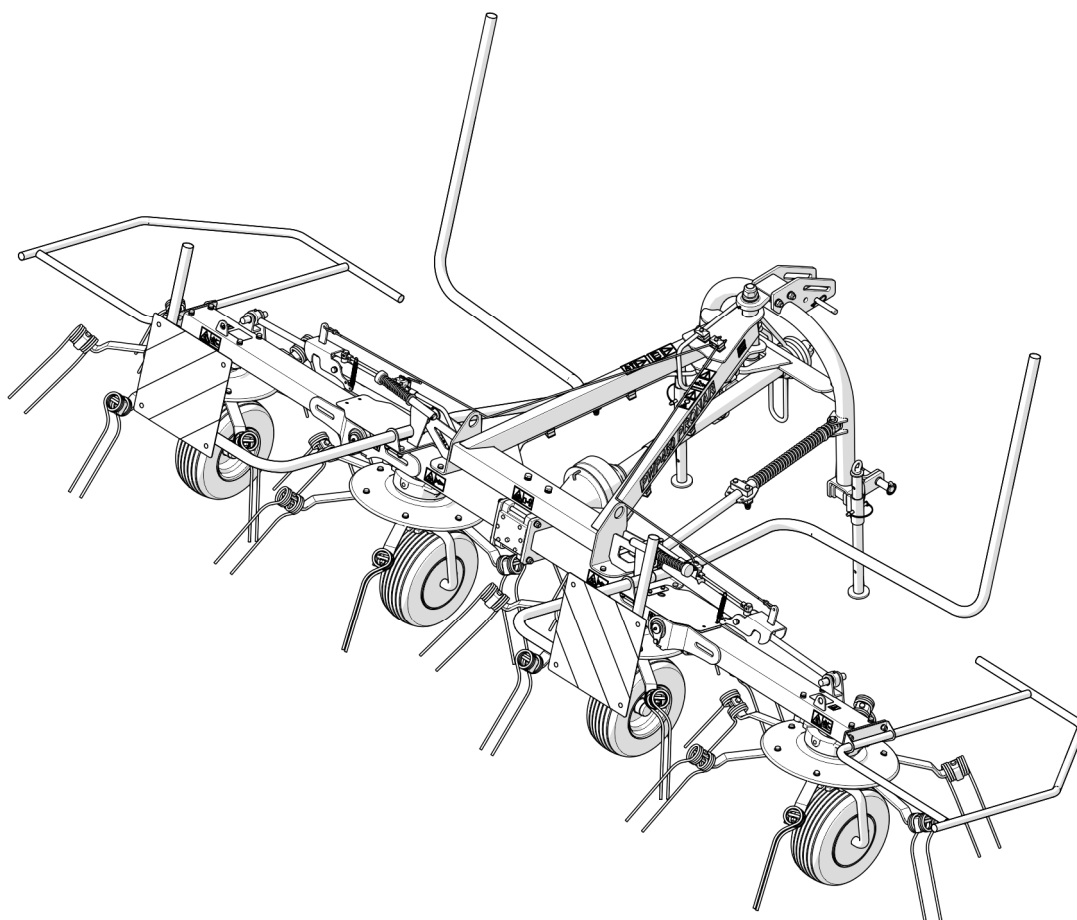

REVISION 2A-08-2016

PUBLICATION NUMBER 533N-00000000-UM



ROTARY TEDDER

PRONAR PWP460

MACHINE IDENTIFICATION

SYMBOL/TYPE:

SERIAL NUMBER:

--	--	--	--	--	--

INTRODUCTION

The information contained in the publication is current at the date of publication. As a result of improvements, some sizes and illustrations contained in this publication may not correspond with the actual state of the machine delivered to the user. The manufacturer reserves the right to introduce constructional changes in the machines manufactured to facilitate operation and improve the quality of their work, without making any current changes to this publication.

The User Manual is the basic part of the machine. Read the contents of this manual and follow all the recommendations contained therein before using the machine. This will guarantee safe operation and ensure trouble-free operation of the machine. The machine was constructed in accordance with applicable standards, documents and current legal regulations.

The User Manual describes the basic principles of safe use and operation of the PWP460 rotary tedder. If the information contained in the operating instructions does not turn out to be comprehensible, please contact the sales office where the machine was purchased or to the Manufacturer.

MANUFACTURER'S ADDRESS

*PRONAR Sp. z o.o.
ul. Mickiewicza 101A
17-210 Narew*

CONTACT PHONE NUMBERS

<i>+48 085 681 63 29</i>	<i>+48 085 681 64 29</i>
<i>+48 085 681 63 81</i>	<i>+48 085 681 63 82</i>

SYMBOLS USED IN THE USER MANUAL

Information, descriptions of hazards and precautions as well as instructions and orders related to safe use in the manual are marked with:



and preceded by the word „**DANGER**”. Failure to comply with these recommendations may endanger the health or life of persons operating the machine or unauthorized bystanders.

Particularly important information and recommendations, the observance of which is absolutely necessary, are highlighted in the text with a sign:



and preceded by the word „**CAUTION**”. Failure to comply with these recommendations creates the risk of damage to the machine due to improper handling, adjustment or use.

In order to draw the user's attention to the necessity to perform periodic maintenance, the content of the manual is marked with the following sign:



Additional instructions contained in the manual describe useful information on operating the machine and are marked with a sign:



and preceded by the word „**ADVICE**”.

DESIGNATION OF DIRECTIONS IN THE MANUAL

Left side – the left hand side of the observer facing the machine in the forward direction.

Right side – the right hand side of the observer facing the machine in the forward direction.



PRONAR Sp. z o.o.
ul. Mickiewicza 101 A
17-210 Narew, Polska
tel./fax (+48 85) 681 63 29, 681 63 81, 681 63 82,
681 63 84, 681 64 29
fax (+48 85) 681 63 83
http://www.pronar.pl
e-mail: pronar@pronar.pl

EC DECLARATION OF CONFORMITY OF THE MACHINERY

PRONAR Sp. z o.o. declares with full responsibility, that the machine:

Description and identification of the machinery	
Generic denomination and function:	Rotary Tedder
Type:	PWP460
Model:	-
Serial number:	
Commercial name:	Rotary Tedder PRONAR PWP460

to which this declaration relates, fulfills all the relevant provisions of the Directive **2006/42/EC** of The European Parliament and of The Council of 17 May 2006 on machinery, and amending Directive 95/16/EC (Official Journal of the EU, L 157/24 of 09.06.2006).

The person authorized to compile the technical file is the Head of Research and Development Department at PRONAR Sp. z o.o., 17-210 Narew, ul. Mickiewicza 101A, Poland.

This declaration relates exclusively to the machinery in the state in which it was placed on the market, and excludes components which are added and/or operations carried out subsequently by the final user.

Narew, the 2016-08-10

Place and date

Z-CIA BYKOSTORA
d/ś 18
czł
Roman
niuk

*Full name of the empowered person
position, signature*

TABLE OF CONTENTS

1	GENERAL INFORMATION	1.1
1.1	IDENTIFICATION	1.2
1.2	INTENDED USE	1.3
1.3	EQUIPMENT	1.5
1.4	TERMS OF WARRANTY	1.5
1.5	TRANSPORT	1.6
1.6	THREAT TO THE ENVIRONMENT	1.10
1.7	WITHDRAWAL FROM USE	1.10
2	SAFETY OF USE	2.1
2.1	GENERAL TERMS OF SAFETY	2.2
2.1.1	THE MACHINE USE	2.2
2.1.2	COUPLING AND UNCOUPLING OF THE MACHINE	2.3
2.1.3	THE HYDRAULIC SYSTEM	2.3
2.1.4	TRANSPORT PASSAGE	2.4
2.1.5	MAINTENANCE	2.5
2.1.6	ROTARY TEDDER OPERATION	2.7
2.1.7	OPERATION OF THE PTO	2.7
2.2	DESCRIPTION OF RESIDUAL RISK	2.9
2.3	INFORMATION AND WARNING STICKERS	2.10
3	CONSTRUCTION AND PRINCIPLE OF OPERATION	3.1
3.1	TECHNICAL CHARACTERISTICS	3.2
3.2	GENERAL CONSTRUCTION AND PRINCIPLE OF OPERATION	3.3
3.3	SUSPENSION SYSTEM	3.4

3.4	PRINCIPLE OF OPERATION	3.6
4	TERMS OF USE	4.1
4.1	PREPARATION TO WORK	4.2
4.2	COUPLING THE ROTARY TEDDER WITH THE AGRICULTURAL TRACTOR	4.4
4.3	TRANSPORT PASSAGE	4.8
4.4	SETTING THE TEDDERS TO THE WORKING POSITION AND WORK	4.11
4.4.1	SWITCHING THE TEDDER TO THE WORKING POSITION	4.11
4.4.2	ADJUSTMENT OF THE WORKING POSITION	4.14
4.4.3	TEDDER WORK	4.16
4.5	DISCONNECTING THE TEDDER FROM THE AGRICULTURAL TRACTOR	4.19
4.6	LIGHTING INSTALLATION AND ADDITIONAL MARKING (OPTIONAL)	4.20
4.6.1	CONSTRUCTION	4.20
4.6.2	USAGE AND MAINTENANCE	4.22
5	TECHNICAL SUPPORT	5.1
5.1	TECHNICAL INSPECTION	5.2
5.2	INSPECTION AND REPLACEMENT OF THE SPRING FINGERS	5.3
5.3	OPERATION OF THE MAIN GEAR	5.4
5.4	HYDRAULIC SYSTEM OPERATION	5.6
5.5	LUBRICATION	5.8
5.6	SCREW CONNECTIONS TIGHTENING	5.11
5.7	STORAGE	5.12
5.8	FAULTS AND HOW TO REMOVE THEM	5.13

CHAPTER

1

**GENERAL
INFORMATION**

1.1 IDENTIFICATION

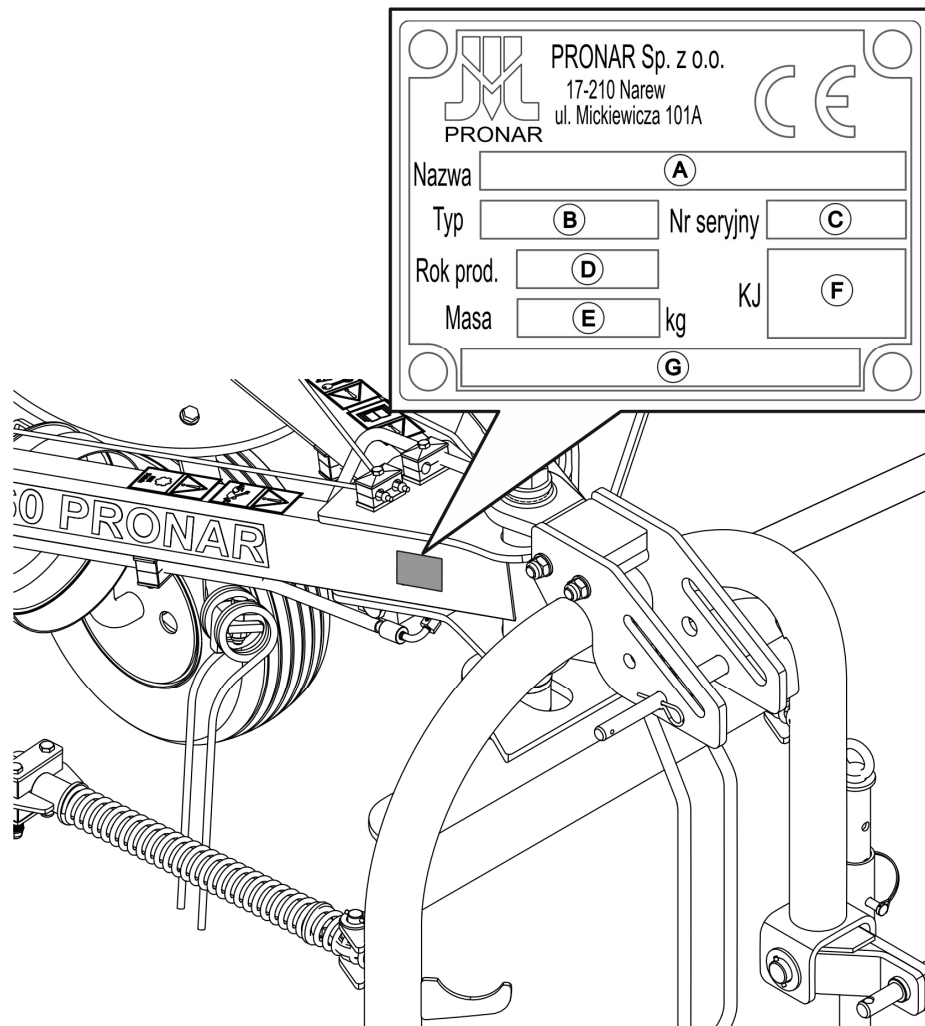

FIGURE 1.1 Location of the nameplate.

The PWP460 rotary tedder is marked with a data plate located on the right side of the machine supporting frame (FIGURE 1.1). When purchasing the machine, check that the serial numbers on the machine match the number entered in the *WARRANTY CARD*, in the sales documents and in the *USER MANUAL*.

The meaning of the individual fields on the nameplate (FIGURE 1.1) is shown in the table below:

- A - machine name, B - machine type/symbol
- C - serial number, D - production year,
- E - total weight [kg], F - Quality Control mark,
- G - machine name, continued

1.2 INTENDED USE

PRONAR PWP460 rotary tedder was constructed in accordance with applicable safety requirements and machine standards.

The rotary tedder is designed for agricultural work: tedding cut swaths (straw, grass, hay) on non-stony grassland with an even surface. Any other use of the machine is prohibited.

Transportation of people, animals and other materials is forbidden and considered as not in accordance with the intended use. When operating the machine, follow the road traffic regulations and transport regulations in force in a given country, and any violation of these regulations is treated by the Manufacturer as use contrary to its intended use.

CAUTION



The rotary tedder may not be used for purposes other than those for which it is intended in particular:

- transport people and animals,
- to transport any materials or items.

Intended use includes all activities related to proper and safe operation and maintenance of the machine. Therefore, the user is obliged to:

- get acquainted with the contents of the *USER MANUAL* and comply with its recommendations,
- understand the principle of machine operation and the safe and proper operation,
- act in compliance with established maintenance and adjustment plans,
- act in compliance with general safety regulations during work,
- accident prevention,
- comply with road traffic regulations and transport regulations in force in the country in which the machine is used,
- read the tractor operator's manual and the PTO shaft operator's manual and observe the recommendations contained in these publications.

TABLE 1.1 Agricultural tractor requirements.

CONTENT	UNIT	REQUIREMENTS
Agricultural tractor suspension system (three-point mechanical linkage)		Mechanical rear linkage, category I or II acc. to ISO 730-1
Rear power take-off (PTO)		
Type	-	Type 1 (1 3/8") acc. to ISO 730-1
Rotation speed	rpm	540
Number of splines on the shaft	pc.	6
PTO rotation direction	-	as clockwise
Required hydraulic outputs of the tractor	-	1 double-acting section with floating position
Other requirements		
Minimal power requirement	kW / KM	22 / 30

The machine may only be used by persons who:

- are familiar with the content of this publication and with the agricultural tractor operator's manual,
- have been trained in the use of the rotary tedder and in work safety,
- have the required authorization to drive and are familiar with the traffic rules and transport regulations.

Repairs related to the machine may be performed only by qualified personnel (during the warranty period, all repairs must be performed at the warranty service indicated by the Manufacturer). Maintenance and repair activities that can be performed by the user are described in *CHAPTER 5*.

Unauthorized repairs and modifications to the tedder are forbidden and will be treated by the Manufacturer as use contrary to the intended use.

1.3 EQUIPMENT

TABLE 1.2 Equipment of the PRONAR PWP460 rotary tedder

EQUIPMENT	STANDARD	OPTIONAL
"User manual"	•	
"Warranty Card"	•	
PTO shaft	•	

Recommended PTO shafts:

- 7102131CE007153 B&P,
- 1620-6200-131-03 Weasler,
- T201310ENC12U34 Comer.

1.4 TERMS OF WARRANTY

"PRONAR "Sp. z o.o. in Narew guarantees the smooth operation of the machine when used in accordance with the technical and operational conditions described in the *USER MANUAL*. Defects revealed during the warranty period will be removed by the Warranty Service. Deadline for completion of repairs is specified in the Warranty Card.

The warranty does not apply to parts and sub-assemblies of the machine, which are subject to wear in normal operating conditions, regardless of the warranty period. The group of these elements includes min. the following parts/components:

- tires,
- spring fingers,
- bearings.

The warranty services only apply to such cases as: mechanical damage not caused by the fault of the user, factory defects of parts, etc.

In the event that damage occurs as a result of:

- mechanical damage caused by the user's fault, road accident,

- from improper operation, adjustment and maintenance, use of the machine contrary to its purpose,
- use of a damaged machine,
- repairs carried out by unauthorized persons, improper repairs,
- making arbitrary changes in the machine design,

the user loses the warranty.



ADVICE

You should require the seller to carefully fill out the **WARRANTY CARD** and complaint coupons. The lack of e.g. date of sale or point of sale stamp exposes the user to not accept any complaints.

The user is obliged to immediately report all noticed defects in the paint coatings or traces of corrosion, and order removal of defects regardless of whether the damage is covered by the warranty or not. Detailed warranty conditions are given in the **WARRANTY CARD** attached to the newly purchased machine.

Modifications to the machine without the written consent of the Manufacturer are prohibited. In particular, welding, reaming, cutting and heating of the main machine components that directly affect safety working with not permitted.

1.5 TRANSPORT

The rotary tedder is ready for sale completely assembled and does not require packing. Only the machine's technical documentation and any additional equipment elements are packed.



CAUTION

When transporting independently, the agricultural tractor operator should read the instructions and follow the recommendations contained therein. When being transported by road, the tedder must be attached to the platform of the means of transport in accordance with the safety requirements during transport. The driver of the car should exercise particular caution while driving. This is due to the vehicle's centre of gravity shifting upwards with the loaded machine.

Delivery to the user is carried out by road transport or independent transport. It is allowed to transport after connecting it to an agricultural tractor, provided that the tractor driver acquaints himself with the tedder's instruction manual, especially with the safety information

and the principles of connecting and transporting it on public roads. Driving of the tractor with the rotary tedder connected is forbidden during the period of limited visibility.

When loading and unloading the tedder, comply with the general principles of workplace health and safety for reloading work. Persons operating reloading equipment must have the required permissions to use these devices.

The tedder should be attached to the lifting equipment in places designed for this purpose (FIGURE 1.2), i.e. to the transport eyes (4) and to the central connector pin (5). The fastening points are marked with an information sticker. It is recommended that for the time of moving and transporting the tedder is set to the transport position, i.e. the right (1) and left (2) tedder module should be lifted up, and the supports (3) lowered downwards. (see "CHAPTER 4.3: TRANSPORT RUN "). In the event that ropes or belts of reloading devices can catch on protruding parts of the machine placed in the transport position, they must also be dismantled. When lifting the tedder, be especially careful due to the possibility of tilting the machine and the risk of injuries from protruding parts of the machine.

**CAUTION**

It is forbidden to attach slings and any kind of cargo securing elements to the hydraulic cylinders.

**ADVICE**

During loading, the rotary tedder should be set in the transport position. (FIGURE 1.2)

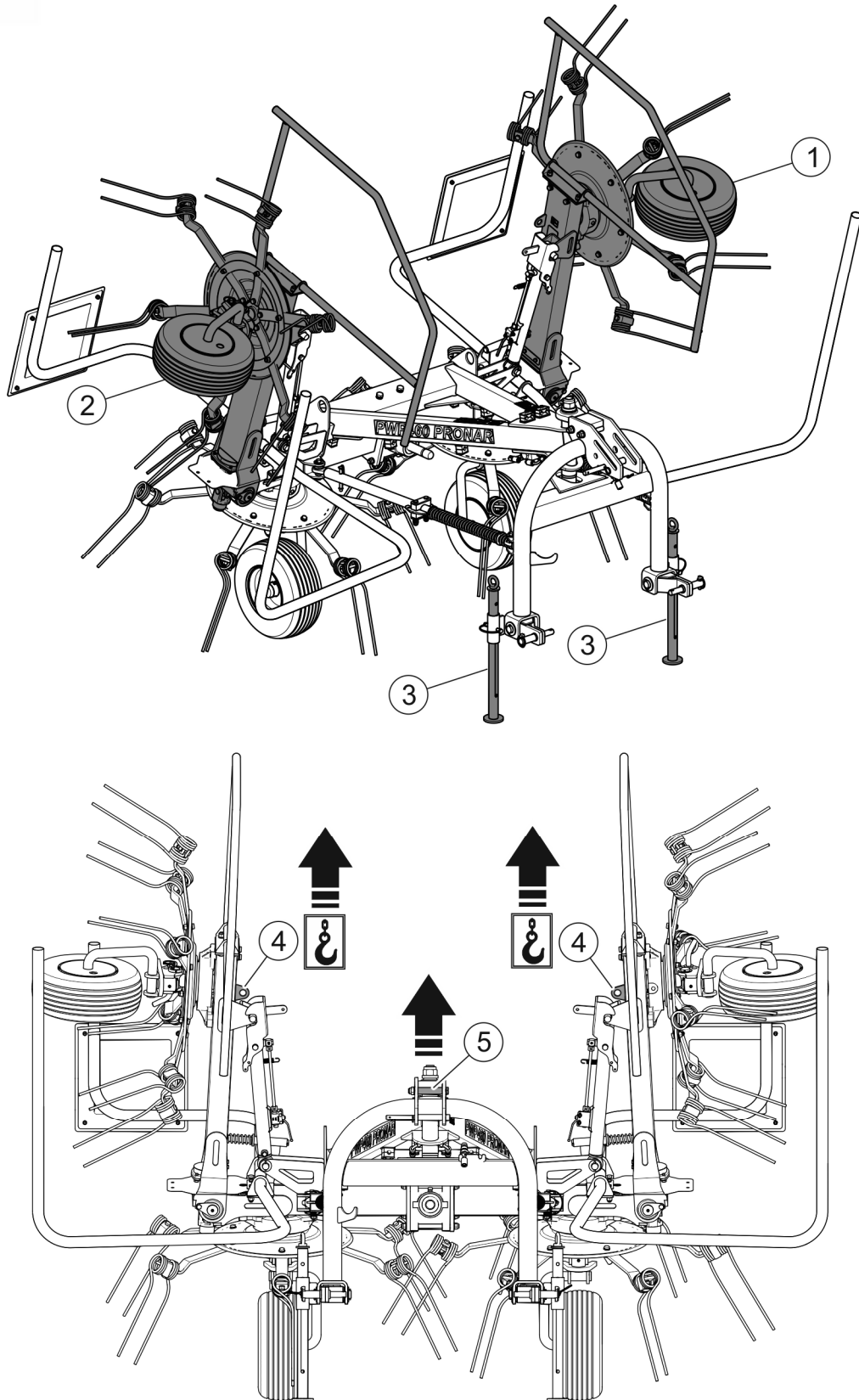



FIGURE 1.2 Transport position and points of attachment of the rotary tedder during loading.

(1) - right tedder module; (2) - left tedder module; (3) - supports; (4) - transport eye; (5) - central connector mounting pin.

The machine should be securely attached to the platform of the means of transport with the use of belts or chains equipped with a tensioning mechanism. The securing measures must have a valid safety certificate. Chocks or other elements without sharp edges should be placed under the tedder wheels to prevent it from rolling. Chocks must be attached to the vehicle's platform. Be especially careful when lifting the machine. During reloading work, particular care should be taken not to damage the tedder's fittings and the paint coating.



CAUTION

Nobody is allowed to stay in the maneuvering area when transferring the rotary tedder to another means of transport.

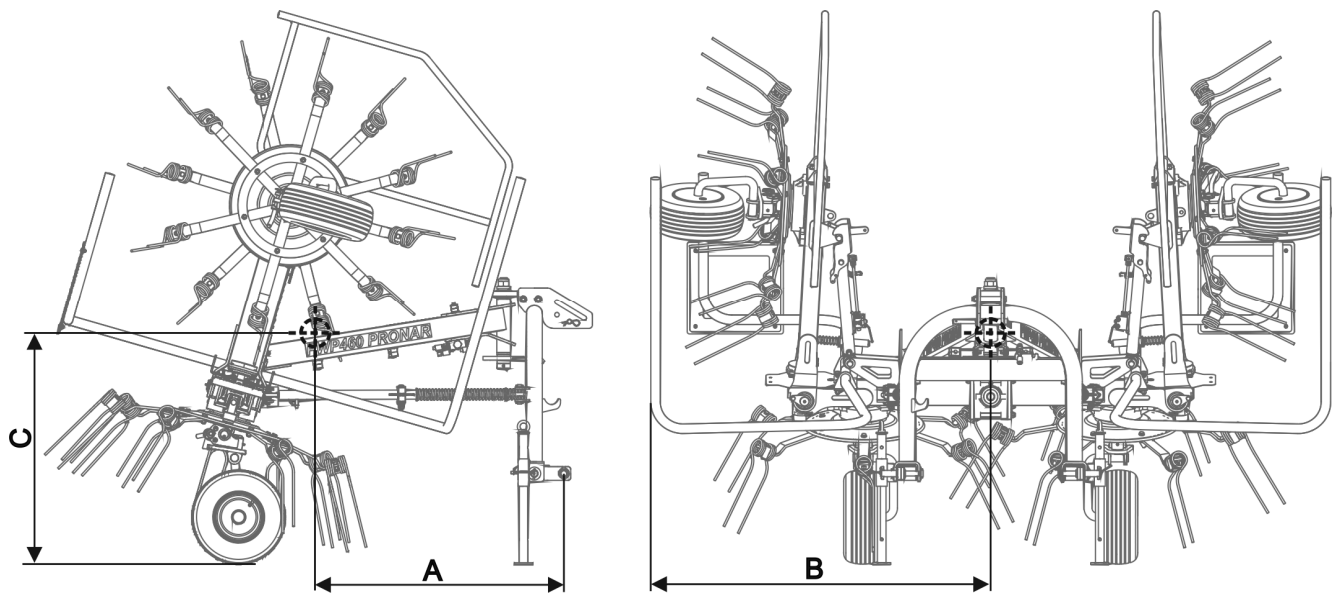

FIGURE 1.3 Position of the center of gravity of the rotary tedder in the transport position.

TABLE 1.3 Location of the center of gravity.

Dimensions (FIGURE 1.3)	Unit	PWP460
A	mm	1210
B	mm	1495
C	mm	990

1.6 THREAT TO THE ENVIRONMENT

A hydraulic oil leak is a direct threat to the natural environment because of its limited biodegradability. When carrying out maintenance and repair work where there is a risk of leakage of oil, this work should be carried out in rooms with an oil resistant surface. In the event of oil leaking into the environment, first of all contain the source of the leak, and then collect the leaked oil using available means. Collect oil residue with sorbents or mix the oil with sand, sawdust or other absorbent materials. Collected oil contaminants should be stored in an airtight and marked container, resistant to hydrocarbons, and then transferred to an oil waste disposal point. The container should be kept away from heat sources, flammable materials and food.

It is recommended to store the oil which has been used up or is unsuitable for further use due to the loss of its properties in its original packaging in the same conditions as described above.

1.7 WITHDRAWAL FROM USE

If the user decides to withdraw the machine from use, comply with the provisions in force in the given country regarding withdrawal from use and recycling of machines withdrawn from use.

Before dismantling the machine, the oil from the hydraulic system and gear must be completely removed. The location of the drain plugs and the method of removing oil are described in Chapter 5.

In the event of parts being replaced, worn or damaged parts should be taken to a recycling centre. Used oil as well as rubber or plastic elements should be taken to plants dealing with the utilization of this type of waste.



CAUTION

During disassembly, use appropriate tools and use personal protective equipment, i.e. protective clothing, footwear, gloves, glasses, etc.

Avoid oil contact with skin. Do not allow used oil to spill.

CHAPTER

2

SAFETY OF USE

2.1 GENERAL TERMS OF SAFETY

2.1.1 THE MACHINE USE

- Before using the machine, the user should carefully read the content of this document and the *WARRANTY CARD*. During their operation, all recommendations contained therein must be observed.
- The tedder may only be used and operated by persons qualified to drive agricultural tractors and trained in the use of the machine. The rotary tedder is operated by one person.
- If the information contained in the User Manual is difficult to understand, contact a seller who runs an authorized technical service on behalf of the manufacturer, or contact the manufacturer directly.
- Careless and improper use and operation of the machine, and non-compliance with the recommendations given in this User manual is dangerous to your health.
- Be aware of the existence of a minimal risk of danger, therefore the application of the principles of safe use and sound behaviour should be the basic principle of using a machine.
- The machine must not be used by persons who are not authorized to drive agricultural tractors, including children, people under the influence of alcohol or other drugs.
- Non-compliance with the rules of safe use poses a threat to the health of the operating and bystanders.
- The machine may not be used for purposes other than those for which it was intended. Everyone who uses the machine in a manner contrary to its intended use, thus takes full responsibility for all consequences arising from its use. Use of the machine for purposes other than envisaged by the Manufacturer is inconsistent with the purpose of the machine and may void the warranty.
- The machine may only be used when all the safety guards and other protective elements are technically sound and correctly positioned. In the event of damage or loss of the covers, they must be replaced with new ones.

2.1.2 COUPLING AND UNCOUPLING OF THE MACHINE

- Before attaching the machine, check the technical condition of the hitch system of the machine and the tractor.
- It is forbidden to connect the machine to an agricultural tractor if the machine's suspension system is not compatible with the agricultural tractor's suspension system.
- When connecting the machine to a tractor, use only the tractor's rear three-point mechanical linkage. After hitching the machine, check the safeguards. Read the tractor operating instructions.
- Only original pins and safeguards should be used to hitch the machine to a tractor.
- The tractor to which the tedder will be attached must be technically efficient and must meet the requirements set by the tedder manufacturer.
- Take special care when connecting the machine.
- When attaching, there must be nobody between the tedder and the agricultural tractor.
- Disconnecting the tedder from the tractor is prohibited if the tedder is not supported on wheels and parking supports. Be especially careful when uncoupling the equipment.
- Connecting and disconnecting may only take place when the machine's drive is disconnected and the tractor is disconnected and stationary.
- When disconnected from the tractor, the tedder must be based on a stable, level ground, supported with supports and secured against rolling away using wheel wedges or other elements without sharp edges.

2.1.3 THE HYDRAULIC SYSTEM

- The hydraulic system is under high pressure during operation.
- Regularly check the technical condition of connections and hydraulic hoses. Oil leaks are inadmissible.
- In the event of failure of the hydraulic system, the machine must be decommissioned until the failure is remedied.

- When connecting or disconnecting the hydraulic conduit to the tractor's hydraulic quick coupler, make sure that the tractor's hydraulic system is not under pressure. If necessary, reduce the residual pressure of the system.
- In the event of injuries being caused by pressurized hydraulic oil, contact a doctor immediately. Hydraulic oil can penetrate the skin and cause infection. If the oil gets into the eyes, rinse with plenty of water and if irritation occurs, contact a doctor. In the event of contact of oil with skin, wash the area of contact with water and soap. Do not use organic solvents (petrol, kerosene).
- Use hydraulic oil recommended by the manufacturer. Never mix two types of oil.
- It is forbidden to store hydraulic oil in packaging intended for food storage.
- Rubber hydraulic conduits must be replaced every 4 years regardless of their technical condition.
- Repairs and replacements of hydraulic system elements should be entrusted to appropriately qualified persons.

2.1.4 TRANSPORT PASSAGE

- When driving on public roads, comply with the road traffic regulations in force in the country in which the machine is used.
- Do not exceed the maximum speed resulting from restrictions on road conditions and project restrictions. Adjust the speed to the prevailing road conditions and restrictions resulting from road traffic regulations.
- Before starting the journey, the tedder must be folded to the transport position and raised using the rear three-point linkage.
- When preparing the tedder for transport, check that the mechanical locks of the tipping cylinders are properly engaged and that the hydraulic valves of these cylinders are in the CLOSED position.
- It is forbidden to leave the tedder raised when the tractor is parked. The tedder should be lowered when it is parked.
- It is forbidden to travel with the tedder in the working position.
- The tedder may not be used or transported in conditions of limited visibility.
- It is forbidden to transport people on the machine and transport any materials.

- Before using the machine always check its technical condition, especially in terms of safety. In particular, check the technical condition of the linkage and connection elements of the hydraulic system.
- It is forbidden to leave the tractor operator's position while driving.
- Reckless driving and excessive speed can cause an accident.

2.1.5 MAINTENANCE

- During the warranty period, any repairs may only be carried out by a Warranty Service authorized by the manufacturer. It is recommended that any repairs are carried out by specialized workshops.
- In the event of any faults or damage, the machine should be decommissioned until repaired. It is forbidden to use a damaged machine.
- During work, use appropriate, close-fitting protective clothing, gloves and the right tools. In case of works related to the hydraulic system, it is recommended to use oil-resistant gloves and protective glasses.
- Any modification of the machine releases PRONAR Narew from any liability for damage or injury.
- Before undertaking any work on the machine, switch off the tractor engine and wait for all rotating parts of the machine to stop.
- Regularly check the technical condition of safety devices and correct tightening of screw connections.
- Regularly inspect the machine in accordance with the scope specified by the Manufacturer.
- It is forbidden to perform maintenance or repair work under the raised and unsecured machine.
- Before commencing the repair work on hydraulic system, reduce oil pressure.
- Perform maintenance and repair activities applying general principles of health and safety at work. In the event of a cut, the wound should be immediately washed and disinfected. In case of serious injuries consult a physician.
- Repair, maintenance and cleaning work should only be carried out with the tractor engine switched off and the ignition key removed. The agricultural tractor must be

secured with the parking brake. Secure the tractor cab against unauthorized access.

- If it is necessary to replace individual parts, use only parts recommended by the manufacturer. Failure to comply with these requirements may endanger the health or life of bystanders or operator, cause damage to the machine and constitute the basis for withdrawing the warranty.
- Check the condition of protective elements, their technical condition and correct fastening.
- In the event of work requiring the tedder to be raised, use properly certified hydraulic or mechanical lifts for this purpose. After lifting the machine use stable and durable supports. Work must not be carried out under the machine which has only been raised with the three-point linkage.
- It is forbidden to support the machine with fragile elements (bricks, hollow bricks, concrete blocks).
- After completing work associated with lubrication, remove excess grease or
- The machine should be kept clean in order to reduce the risk of fire.
 - When working with tires, the tedder should be secured against rolling by placing wedges or other elements without sharp edges under the wheels.
 - Repair work on wheels or tires should be carried out by persons trained and authorized to do so. These works should be carried out using appropriately selected tools.
 - Check tire pressure regularly.
 - The paint coating should be cleaned before welding. The fumes of burning paint are poisonous to humans and animals. Welding work should be carried out in a well-lit and ventilated room.
 - During welding work, pay attention to flammable or fusible elements. If there is a risk of ignition or damage, they must be removed or covered with non-flammable material before welding. The tedder must be disconnected from the tractor before commencing electric welding.

2.1.6 ROTARY TEDDER OPERATION

- Before using the tedder each time check its technical condition. In particular, check the technical condition of the hitch system, chassis, correct mounting of the arms and spring fingers of the rotary mechanism and the safety guards.
- It is forbidden to use a damaged machine.
- Before starting the tedder drive, set the tedder to the working position.
- Use the correct setting of the working position while tedding.
- During the tedding on the edges of streets, public roads, or on rocky terrain, there is a risk that the thrown stones and other foreign objects may pose a threat to bystanders and vehicles.
- Before starting the machine, make sure that there are no bystanders (especially children) or animals in the danger zone (area up to 50 meters from the tedder). The machine operator is obliged to ensure proper visibility of the machine and the working area.
- When using the tedder, it is not allowed to use the PTO rotational speed higher than 540 rpm. It is prohibited to overload the shaft and tedder and to suddenly engage the clutch. Do NOT overload shaft and tedder and do NOT engage the clutch suddenly.
- Before starting the tedder drive, make sure that the PTO rotation direction is correct.
- It is forbidden to leave the tractor cabin when the machine drive is running.
- It is forbidden to stay in the work area of the rotary tedder. While driving backwards and during turns, the tedder drive must be disengaged.
- Use the recommended working speed while tedding.

2.1.7 OPERATION OF THE PTO

- During reversing and during turns, the PTO drive must be disengaged.
- The machine may only be connected to the tractor with the appropriately selected PTO shaft recommended by the Manufacturer.
- Adjust the length of the articulated telescopic shaft to the cooperating tractor in accordance with the shaft's instruction manual.

- The PTO shaft has markings on the housing indicating which end of the shaft should be connected to the tractor.
- Never use a damaged PTO shaft as it may cause an accident. A damaged shaft must be repaired or replaced.
- Disconnect the shaft drive each time when there is no need to drive the machine or when the tractor and tedder are in an unfavourable angular position with respect to each other.
- The chains preventing the shaft cover from turning while the shaft is working, should be secured to a fixed structural element of the tedder.
- It is forbidden to use safety chains to support the shaft during standstill or transporting of the machine.
- Before starting work, familiarize yourself with the propeller shaft operating instructions provided by the shaft manufacturer and follow the recommendations contained therein.
- The drive shaft must be equipped with covers. It is forbidden to use the shaft with damaged or missing safety elements.
- After installing the shaft, make sure that it is correctly and securely connected to the tractor and the tedder.
- Before starting PTO shaft make sure that the PTO rotation direction is correct.
- Before disconnecting the shaft, turn off the tractor engine and remove the key from the ignition.
- It is forbidden to wear loose clothing, loose belts or anything that could get caught in the rotating shaft. Contact with rotating PTO shaft may cause serious injury.
- It is forbidden to walk over and under the shaft and stand on it both during work and when the machine is at a standstill.

2.2 DESCRIPTION OF RESIDUAL RISK

Pronar Sp. z o. o. in Narew made every effort to eliminate the risk of an accident. However, there is some residual risk that can lead to an accident and is primarily associated with the following activities:

- using the the machine contrary to its purpose,
- being between the tractor and the machine during engine operation and when connecting the machine,
- being on the machine during engine work,
- operation of the machine with the covers removed or inoperative,
- failure to maintain a safe distance from hazardous areas or occupying a place in these zones during machine operation,
- operation of the machine by unauthorized persons or persons under the influence of alcohol,
- cleaning, maintenance and technical inspection with connected and running tractor,
- using an inoperative PTO shaft

Residual risk can be reduced to a minimum by following these recommendations:

- prudent and leisurely machine operation,
- sensible application of the remarks and recommendations contained in the operating instructions,
- performing maintenance and repair work in accordance with the principles of operating safety,
- carrying out maintenance and repair work by trained persons,
- use of tightly fitting protective clothing,
- securing the machine against access by unauthorized persons, especially children.
- keeping a safe distance from prohibited and dangerous places,
- prohibition of being on the machine while it is working

2.3 INFORMATION AND WARNING STICKERS

The rotary tedder is marked with information and warning stickers mentioned in Table 2.1. The machine user is obliged to ensure that the inscriptions, warning and information symbols placed on the machine are legible throughout the entire period of use. In the event of their destruction, they must be replaced. Labels with inscriptions and symbols are available from the Manufacturer or in the place where the machine was purchased. New assemblies replaced during repair must be marked again with the appropriate safety signs. When cleaning the machine, do not use solvents that may damage the label coating and do not direct a strong water jet.

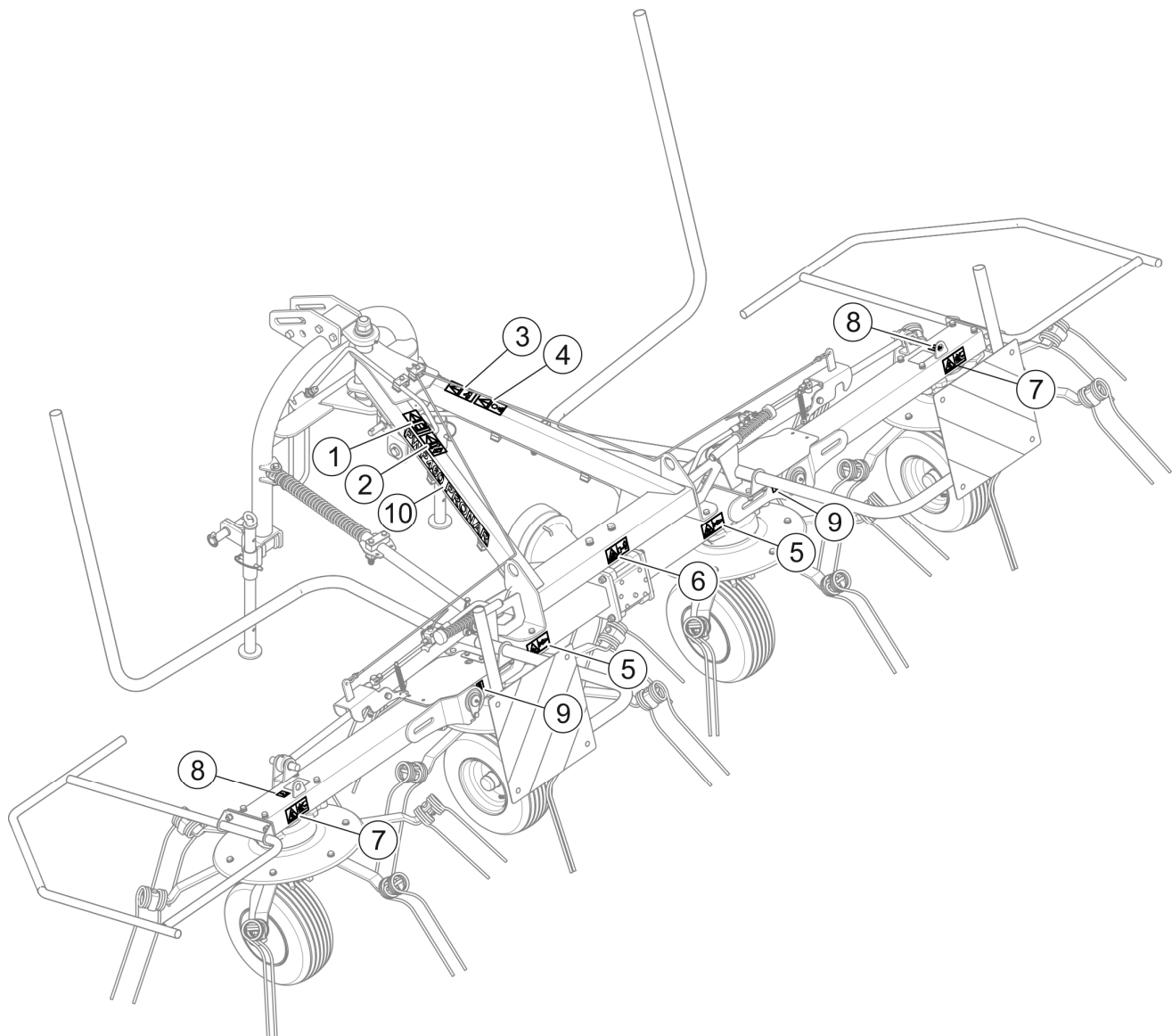
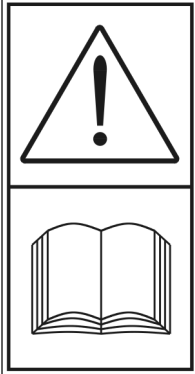
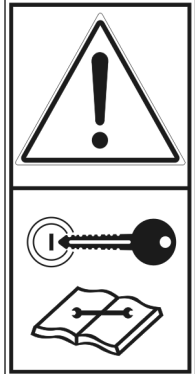

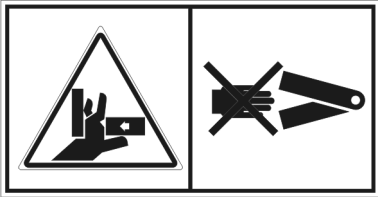
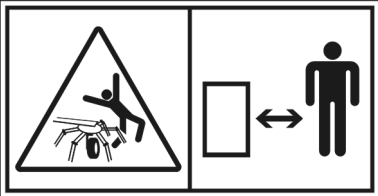





FIGURE 2.1 Position of information and warning stickers.

Description of the stickers (TABLE 2.1)

TABLE 2.1 INFORMATION AND WARNING Stickers

ITEM	STICKER	MEANING
1		<p>Before starting work, read the User's Manual.</p>
2		<p>Before commencing servicing or repairs, turn off the engine and remove the key from the ignition switch.</p>
3		<p>Danger related to the rotating articulated telescopic shaft.</p>
4		<p>The permissible PTO rotation speed is 540 rpm</p>

ITEM	STICKER	MEANING
5		<p>Do not reach into the crushing area if the elements can move. There is a risk of crushing your fingers or hands</p>
6		<p>Danger of being struck by rotating machine parts. Keep a safe distance from the raking assembly.</p>
7		<p>Danger of impact due to displacement of the machine units into transport or working position.</p>
8		<p>Marking of transport handles.</p>
9		<p>Marking of lubrication points.</p>
10	<p>PWP460 PRONAR</p>	<p>Type of machine</p>

CHAPTER

3

**CONSTRUCTION AND
PRINCIPLE OF
OPERATION**

3.1 TECHNICAL CHARACTERISTICS

TABLE 3.1 GENERAL TECHNICAL DATA

	Unit	PWP460
Dimensions		
Total length	mm	2400
Width in working position	mm	5000
Width in transport position	mm	2990
Height in working position	mm	1700
Height in transport position	mm	2900*
Performance parameters		
Number of rotary elements	pcs.	4
Number of working arms on one rotary element	pcs.	6
Working width	mm	4600
Min. tractor power	KM	30
Maximum PTO speed	rpm	540
Curb weight	kg	600
Working performance	ha/h	5.3
Recommended working speed	km/h	10
Noise level	dB	75
Tires		
Tire	-	16 x 6.5 – 8 (6PR)
Air pressure in the tires	kPa	200
Other information		
Spreading angle adjustment	-	Manually, each wheel separately in the range of 13° -19°
Border tending	-	After manual wheel shifting (each wheel separately)
Raising the rotors to the transport position	-	Hydraulic - synchronized
Terrain copying:		
- up	-	to 30°
- down	-	to 6°

* - height of the axis of the lower pull rods from the ground ~ 850 mm

3.2 GENERAL CONSTRUCTION AND PRINCIPLE OF OPERATION

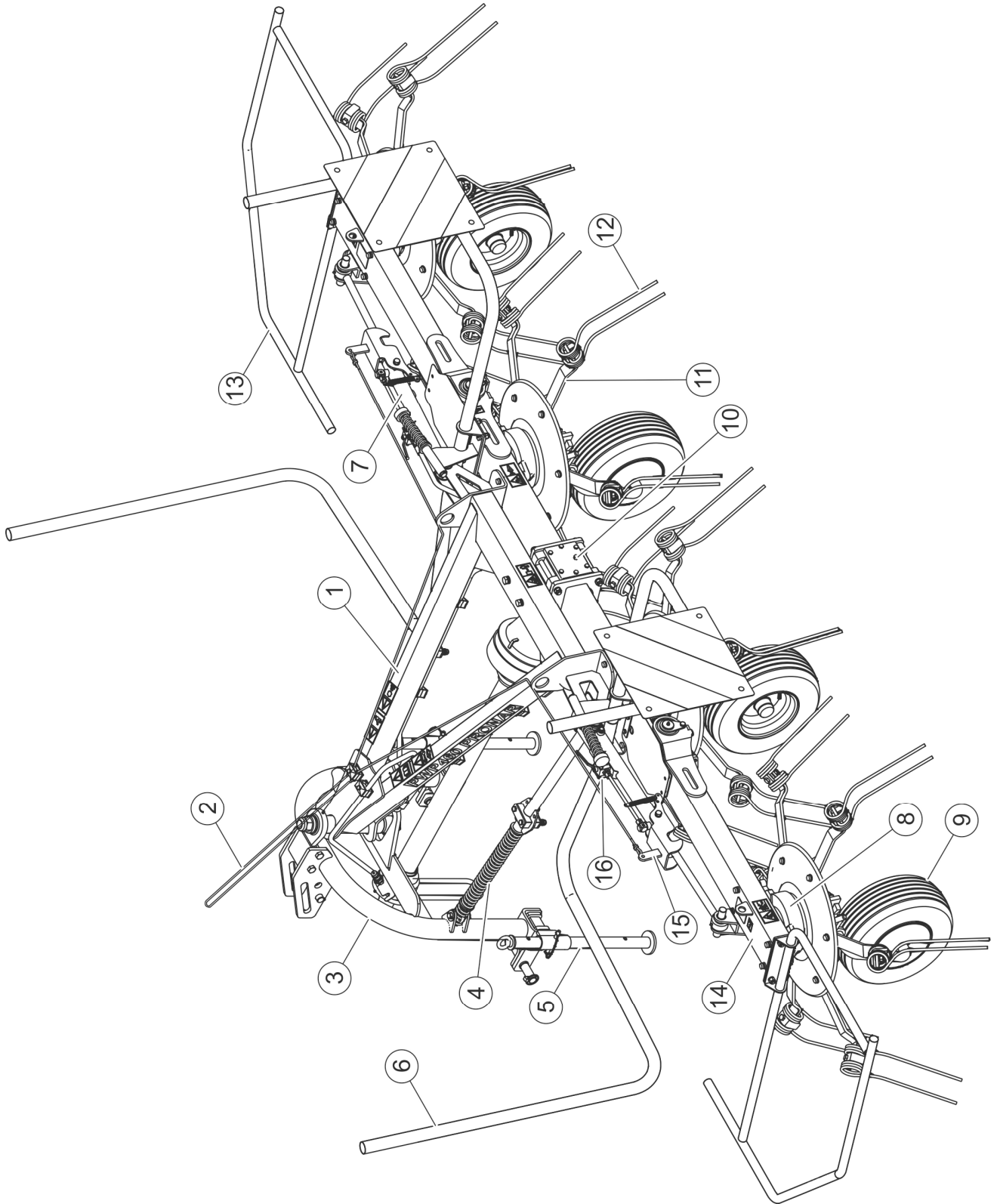

FIGURE 3.1 General construction

(1) support frame, (2) release line, (3) suspension system, (4) vibration dampers, (5) support, (6) vertical protective frame, (7) tilt hydraulic cylinder, (8) rotor gear, (9) road wheel, (10) main gear, (11) rotor working arm, (12) spring fingers, (13) horizontal protective frame, (14) tilting modules of the support frame, (15) mechanical lock, (16) hydraulic valve locking the tilt cylinder.

The construction of the rotary tedder is shown in FIGURE 3.1. The main component of the whole machine is the supporting frame (1) connected via the machine's linkage (3) to the three-point linkage (3-point linkage) of the tractor category I or II. The support frame is amortized by two vibration shock absorbers (4) located between the frame and the tractor's three-point linkage system. In the central part of the support frame there is the main gear (10) of working units, which drives the rotor gears (8) through drive shafts placed in the frame.

The main gear (10) is driven by the PTO shaft of the tractor. The tedder is equipped with four rotating rotors, mounted on road wheels (9). Two outer rotors are mounted on tilting modules of the support frame (14), allowing the machine to be optimally adapted to the unevenness of the ground. They are raised and lowered by the tilt hydraulic cylinders (7) and locked in the transport position by the mechanical interlock (15). The mechanical lock is released by pulling the release cord (2). The actuators are controlled by the tractor's hydraulic system. Each rotor has six working arms (11). Each of the arms is equipped with one pair of spring tines (12) for tedding the swath. They are attached to the arm by means of fastening elements that prevent the fingers from slipping and rotating.

3.3 SUSPENSION SYSTEM

The rotary tedder is connected to the agricultural tractor by means of a suspension system integrated with the machine supporting frame. Figure 3.2 shows the detailed construction of the attachment.

The tedder is adapted to agricultural tractors equipped with a three-point hitch of category I or II. Pins (1) and (2) - external - are used to attach the machine to a tractor equipped with a 3-point linkage of the second category, similarly, pins (3) and (4) - internal - for connecting to a tractor equipped with a 3-point linkage of the I category. The upper pin is common, designed to be attached to the upper hitch point, regardless of the three-point linkage category. The upper pin can be placed in one of the three available sockets (A), (B) or (C).

The upper frame is attached to the hitch assembly by means of a ball joint (10). In the lower part of the frame mounting there is a sleeve (11) which moves in the profiled seat. The frame vibrations are damped by spring shock absorbers located on the left and right side of the tedder.

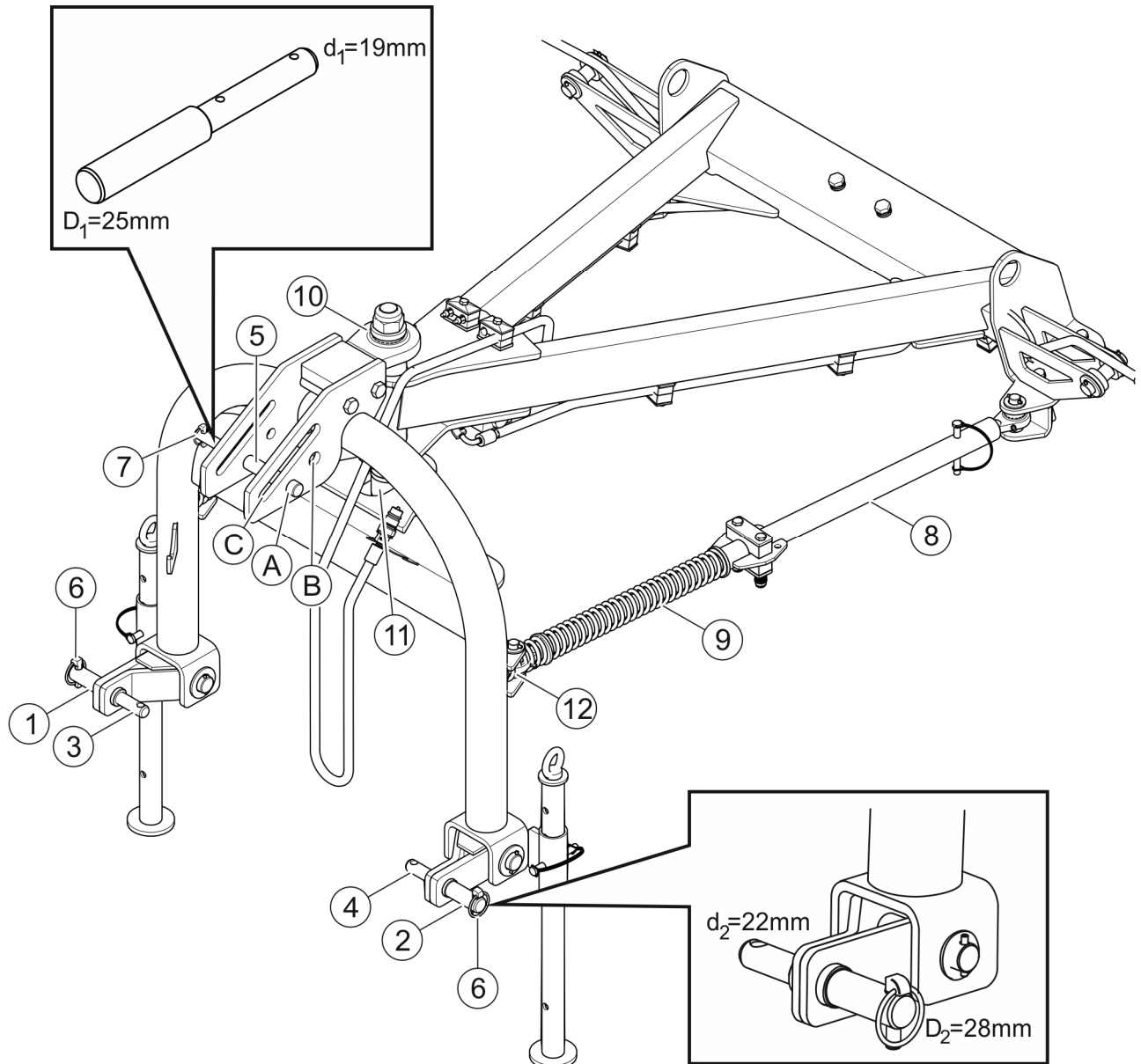

FIGURE 3.2 Suspension system

(1), (2) lower mounting pin (three-point linkage - II category), (3), (4) lower mounting pin (three-point linkage - I category), (5) upper mounting pin, (6), (7) securing cotter pins, (8) shock absorber pin, (9) shock absorber spring, (10) ball joint, (11) bush, (12) shock absorber joints, (A), (B), (C) upper pin mounting sockets.

3.4 PRINCIPLE OF OPERATION

The rotary tedder is equipped with a main transmission driven by the tractor's PTO. The torque is transmitted by means of transmission shafts located in the frame to the individual rotors of the rotors located along the support frame. The design of the rotors ensures a counter-rotating rotation of individual rotors, which enables collision-free rotation of the arms of adjacent rotors and an even spread of the teded material.

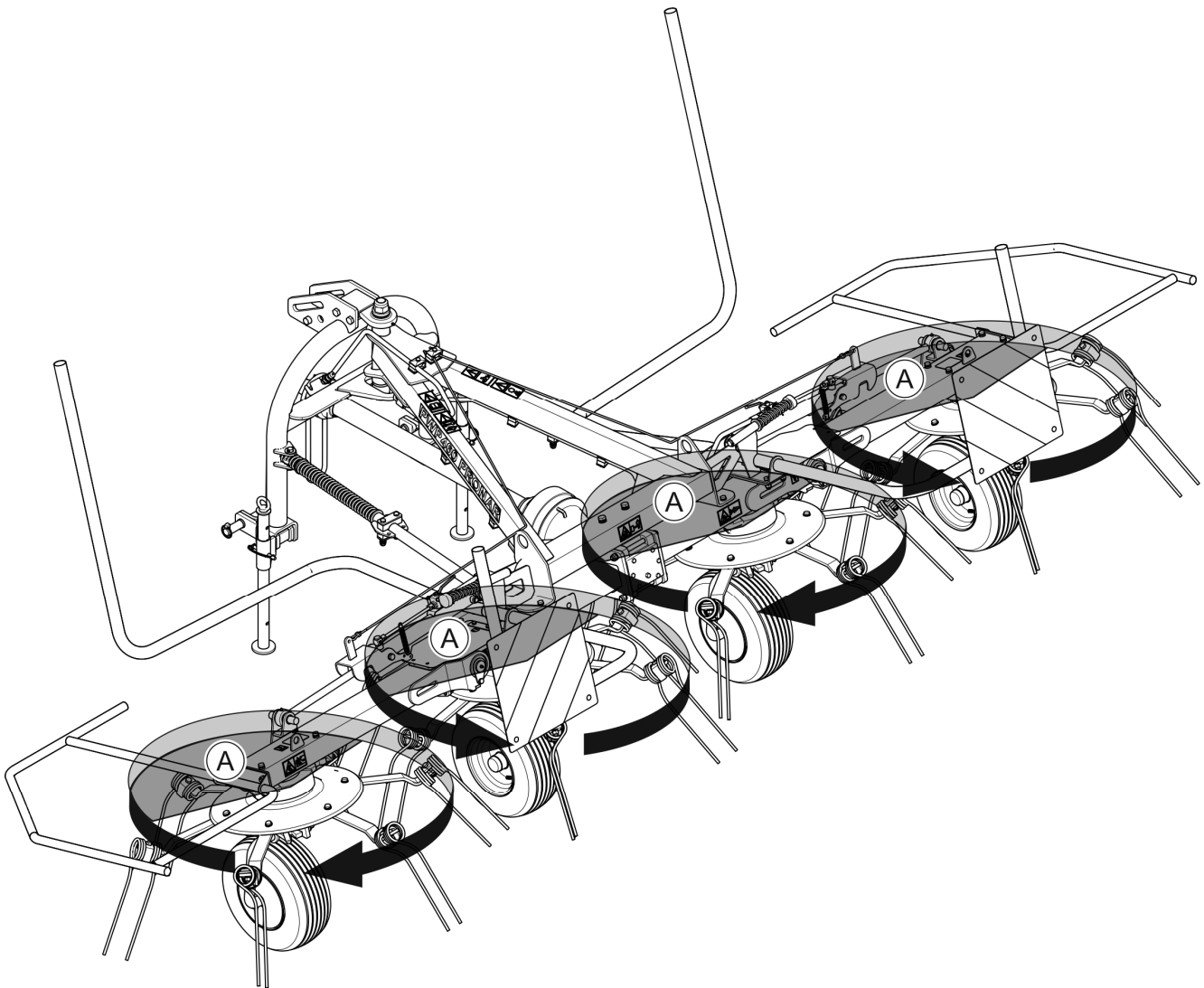

FIGURE 3.3 The principle of operation of the tedder

(A) bedding phase

CHAPTER

4

TERMS OF USE

4.1 PREPARATION TO WORK

The manufacturer ensures that the machine is fully functional, has been checked in accordance with control procedures and is approved for use. However, this does not release the user from the obligation to check the machine after delivery and before first use. The machine is delivered to the user completely assembled.



CAUTION

Before every use of the tedder check its technical condition. In particular, check the technical condition of the linkage, running gear, drive system, completeness of the frames and safety guards, the tedding system and the correct mounting of the tedding fingers.

Before hitching to the tractor, the machine operator must check the technical condition of the tedder and prepare it for a test run. To do this:

- read the contents of this manual and follow the recommendations contained therein, learn about the structure and understand the operation of the machine,
- check the condition of the paint coating,
- carry out a visual inspection of individual machine components in terms of mechanical damage resulting from among others due to improper transport of the machine (dents, punctures, bends or broken details),
- check all lubrication points, lubricate the machine in accordance with the recommendations contained in Chapter 5 "MAINTENANCE",



CAUTION

Before starting work, all lubrication points should be greased.

- check the technical condition of the hydraulic system;
- check the condition of the tires on the road wheels and the air pressure in the tires,
- check the correct mounting of road wheels and rockers,
- check the correct mounting of spring fingers, tedding arms, safety guards,
- check the technical condition of the hitch system pins and securing cotter pins,
- check the level of lubricating oil in the main gear.

If all the above activities have been performed and the technical condition of the machine does not raise any objections, connect it to the tractor. Start the tractor, check individual systems and perform a test run at a standstill. In order to perform the control:

- connect the tedder to the tractor (see Chapter 4.2 „CONNECTING THE ROTARY TEDDER TO THE AGRICULTURAL TRACTOR”)
- lower the right and left module from the transport position to the working position, level the rotors of the tedder with the three-point linkage system so that the spring fingers do not touch the ground,
- start PTO drive.

**DANGER**

Never exceed the PTO speed of 540 rpm. Otherwise, the rotary tedder may be damaged.

Start the tedder drive for a few minutes, during this time check:

- whether there are no knocks and noises from the drive system caused by rubbing metal elements,
- compliance of the tedding system rotation.

Operation of the tedder without load should be smooth, vibrations of the tedding system and the entire machine are unacceptable, as well as tone-changing sounds and vibrations from loose bolted connections. After stopping the tedder, check the fastenings of the tedding tines and the rotor arms. Check whether gear oil is leaking from the main gear.

**DANGER**

Before using the tedder, the user should carefully read the content of this document.

Careless and improper use and operation of the tedder, non-observance of the recommendations contained in these instructions creates a threat to health.

The tedder must not be used by persons who are not authorized to drive agricultural tractors, including children and people under the influence of alcohol or other drugs.

Non-compliance with the rules of safe use poses a threat to the health of the operating and bystanders.

Before starting the tedder with the equipment, make sure that there are no bystanders in the danger zone.

In the event of a fault, locate the fault. If it cannot be removed or its removal may void the warranty, please contact your dealer for an explanation of the problem.

4.2 COUPLING THE ROTARY TEDDER WITH THE AGRICULTURAL TRACTOR

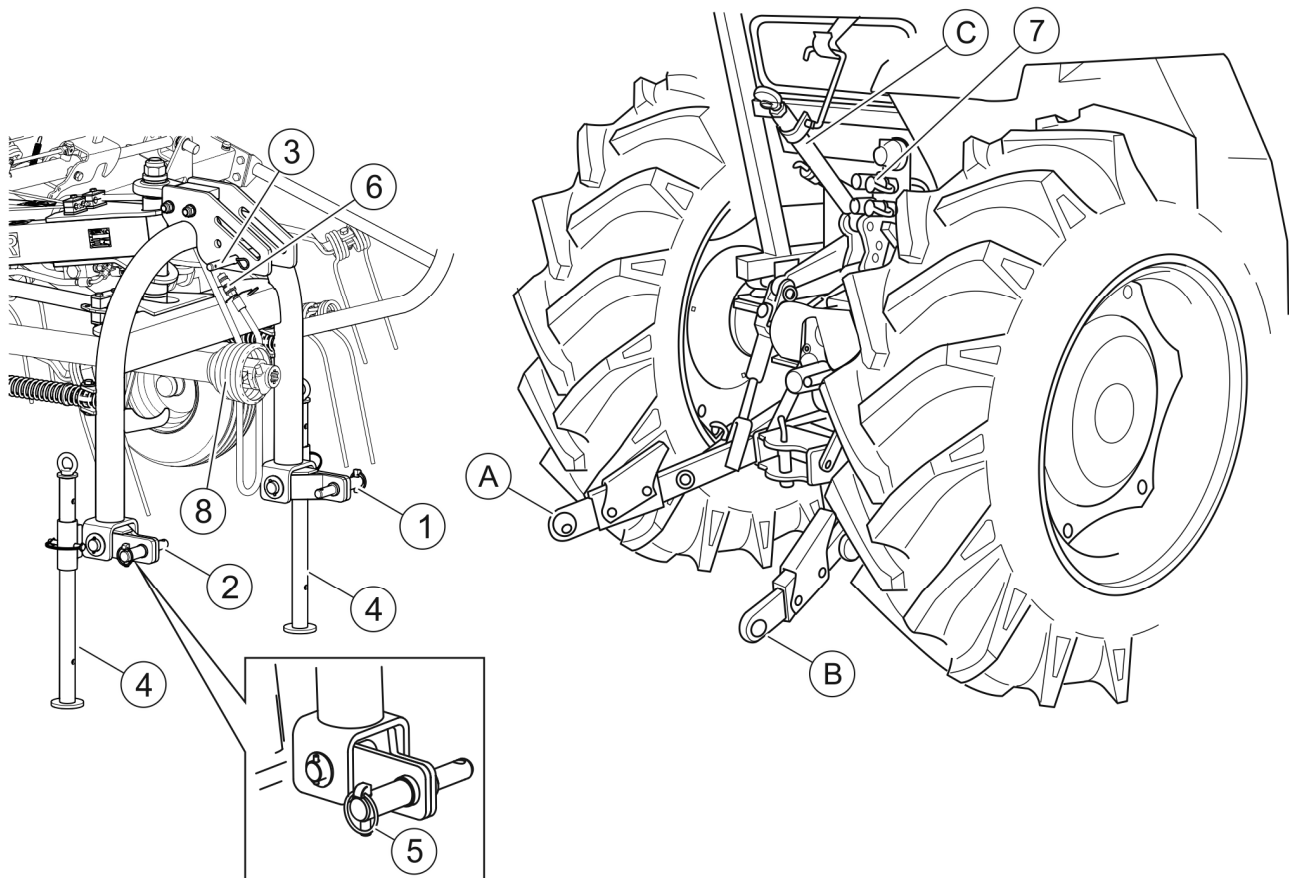

FIGURE 4.1 Coupling the rotary tedder with the agricultural tractor

(1), (2) lower pins of three-point linkage, (3) upper mounting pin, (4) support, (5) securing cotter pin, (6) hydraulic conduit of tilt cylinders, (7) tractor quick couplers, (8) articulated telescopic shaft, (A), (B) lower links of the three-point linkage, (C) upper link of the three-point linkage.



CAUTION

Before proceeding to aggregate the rotary tedder, please read the manual of the agricultural tractor. Follow the recommendations for linkage and attachment points.



DANGER

When hitching, you must not stay between the machine and agricultural tractor. Be especially careful when aggregation the machine.

The rotary tedder may be coupled with an agricultural tractor that meets the requirements of TABLE 1.1 *AGRICULTURAL TRACTOR REQUIREMENTS*.

In order to connect the rotary tedder with the agricultural tractor's rear three-point linkage, follow the recommendations below (FIGURE 4.1):

- Reversing the tractor bring the lower links (A) and (B) of the three-point linkage of the tractor closer to the lower pins (1) and (2) of the tedder.
- Set the draw-bars (A) and (B) of the tractor at the appropriate height.
- Set the draw-bars (A) and (B) of the tractor at the appropriate height.



DANGER

Before hitching the tedder to the tractor, turn off the tractor engine and remove the key from the ignition switch. The tractor must be secured against unauthorized access.

- Connect the lower pins (1) and (2) with the rods (A) and (B) and secure with the use of cotter pins.



CAUTION

The tractor's lower links must be at the same height. Otherwise, the tedder will be tilted to the left or right side, which will result in malfunctions in the machine operation. Appropriate adjustment is made with the use of hangers of the tractor's lower three-point linkage.

- Unlock the tractor's upper link and connect it to the pin (3) of the tedder and secure it with a cotter pin.
- Connect the tractor's rear PTO with the tedder's main gear using the articulated telescopic shaft (8);



DANGER

Before connecting the tractor rear PTO with the articulated telescopic shaft, turn off the tractor engine and remove the key from the ignition switch. The tractor must be secured against unauthorized access.

The use of the articulated telescopic shaft and its technical condition must be in accordance with the instruction manual of the articulated telescopic shaft.

**DANGER**

Before the first start-up, the length of the articulated telescopic shaft should be adjusted according to the guidelines in the shaft manufacturer's operating manual.

- Connect the hydraulic conduit (6) of the tedder to the quick coupler (7) of the hydraulic circuit of the double-acting tractor equipped with the FLOATING position.

**DANGER**

Before connecting the hydraulic system conduit, read the tractor manual and adhere to the manufacturer's recommendations.

**DANGER**

When connecting the hydraulic conduits to the tractor, make sure that the tractor hydraulic system was not under pressure.

- Raise the left and right supports of the tedder (4) and secure them with cotter pins.

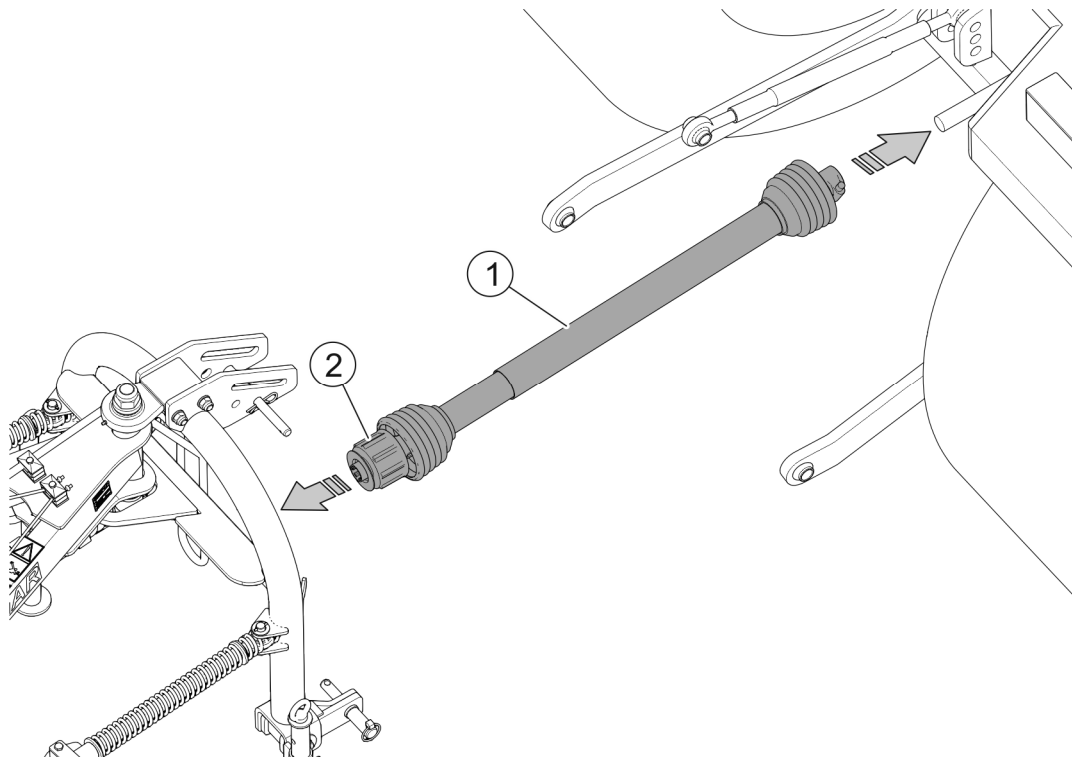

FIGURE 4.2 PTO shaft with an overload clutch

(1) articulated telescopic shaft; (2) safety clutch

The tedder is equipped with an appropriately selected articulated telescopic shaft with an overload clutch (FIGURE 4.2), which prevents damage to the tedder or the tractor. The value of the torque on the shaft is factory set by the manufacturer and cannot be changed independently. Changing the setting of the overload clutch may void the warranty.

Before connecting the tedder to the tractor PTO shaft, it is absolutely necessary to read the manual attached by the manufacturer of the shaft and observe all recommendations contained therein. Before connecting the articulated telescopic shaft, check the technical condition of the guards, the completeness and condition of the securing chains and the general technical condition of the shaft.

The splined ends are appropriately marked and described with information which side should be connected to the tractor.

4.3 TRANSPORT PASSAGE

CAUTION



Before driving on public roads in order to transport the tedder to the workplace and back, the tedder must be folded to the transport position.

When driving on public roads, comply with the road traffic regulations in force in the country in which the machine is used.

Before entering a public road, check that all warning signs on the tedder are properly attached and are visible.

The tedder may not be used or transported in conditions of limited visibility.

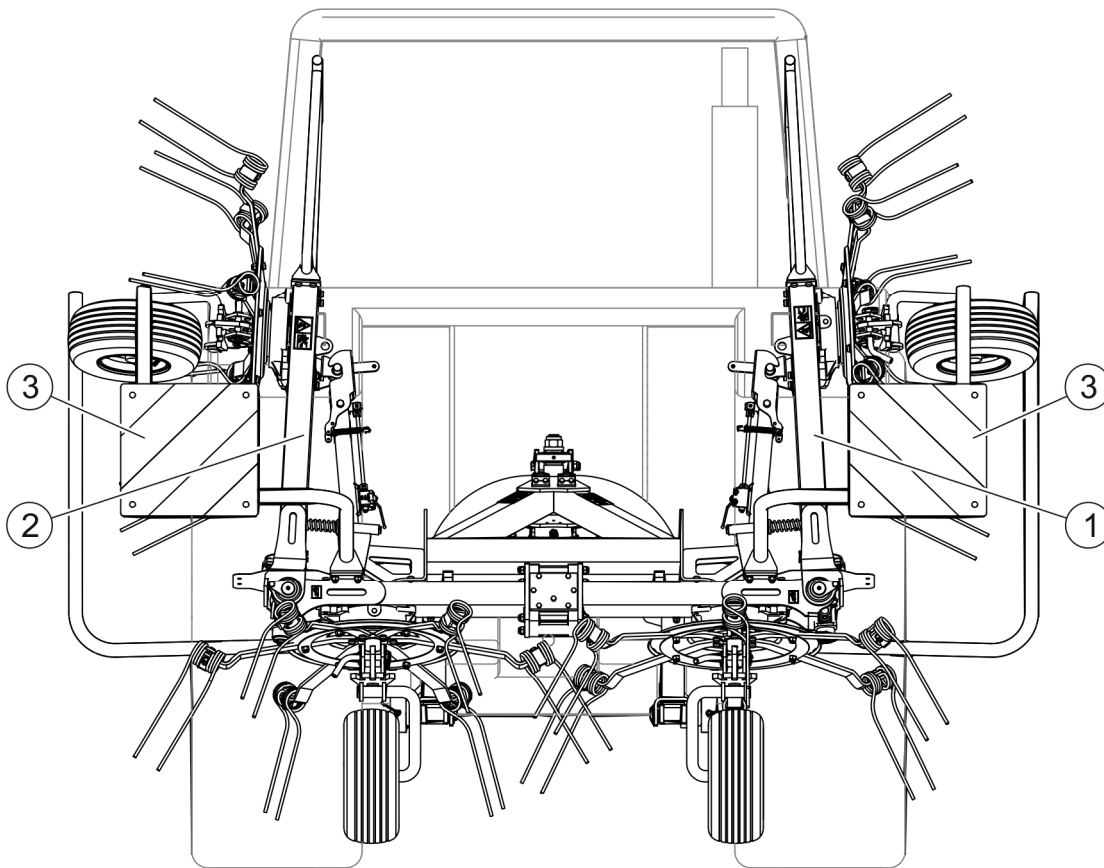

FIGURE 4.3 Transport position of the tedder.

(1) - right rotary module, (2) - left rotary module, (3) - warning signs.

For transport to the workplace and back, set the tedder in transport position (FIGURE 4.3) so that the tedder's width is minimal.

In order to set the tedder to the transport position, perform the following actions (FIGURE 4.4):

- Stop the tractor and lower the tedder onto the support wheels.
- Immobilize tractor with parking brake.

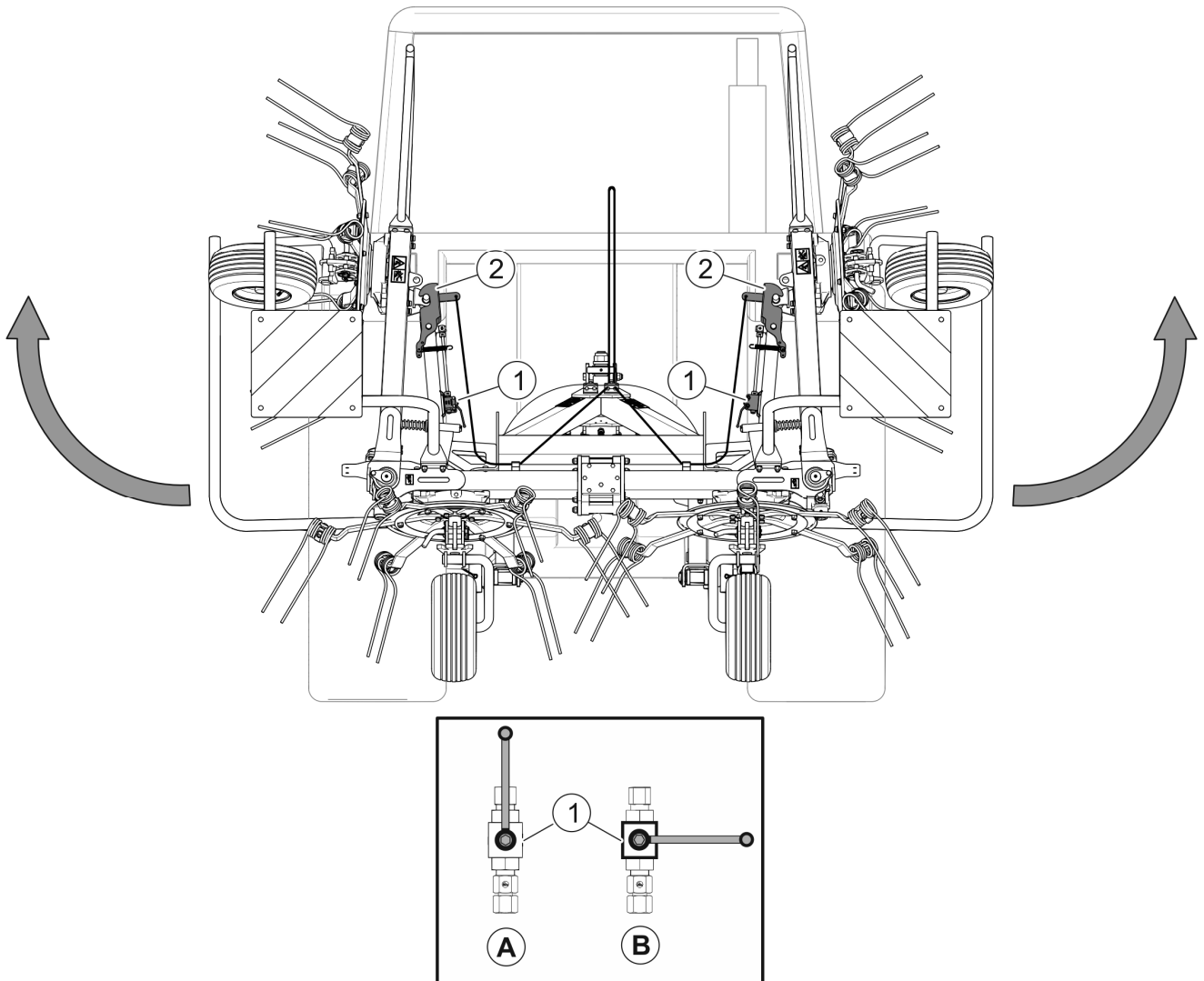

FIGURE 4.4 Setting the tedder to the transport position.

(1) tilt cylinder valves, (2) mechanical lock of the cylinders, (A) OPEN position, (B) CLOSED position.

- While sitting in the tractor, from the operator's seat, slowly set the lever of the hydraulic distributor to the LIFTING position of the tilting cylinders of the right and left rotor modules.
- Lift the right and left tedder rotary modules until the cylinder position is locked with the mechanical cylinder interlock (2).

- Set the lever of the tractor hydraulic distributor controlling the tilt cylinders to the NEUTRAL position.
- Set the valves (1) of the tedder arm tilt cylinders to the "CLOSED" position.
- Set the tedder vibration dampers in the locked position (FIGURE 4.7).
- When transporting the tedder, disconnect the articulated telescopic shaft from the tractor PTO shaft.
- Lift the tedder with the three-point linkage system to the appropriate height above the ground enabling the tedder to be transported.

**DANGER**

When preparing the tedder for transport, check that the mechanical locks of the tipping cylinders are properly engaged and that the hydraulic valves of these cylinders are in the CLOSED position.

**DANGER**

It is forbidden to engage the tractor PTO drive in the transport position of the rotary tedder.

For transporting the tedder, the articulated telescopic shaft should be disconnected from the tractor PTO shaft.

4.4 SETTING THE TEDDERS TO THE WORKING POSITION AND WORK

The tedder transported to the field must be set to the correct working position. Adaptation of the machine to work may only take place in the place where the tedder will work. Driving the machine on the road with the side rotors folded out is prohibited.

4.4.1 SWITCHING THE TEDDER TO THE WORKING POSITION



DANGER

Changing position from transport to working position may only be carried out on level and solid ground. Make sure that no one is in the swivel range of the rotor arms within the reach of the rotor arms.

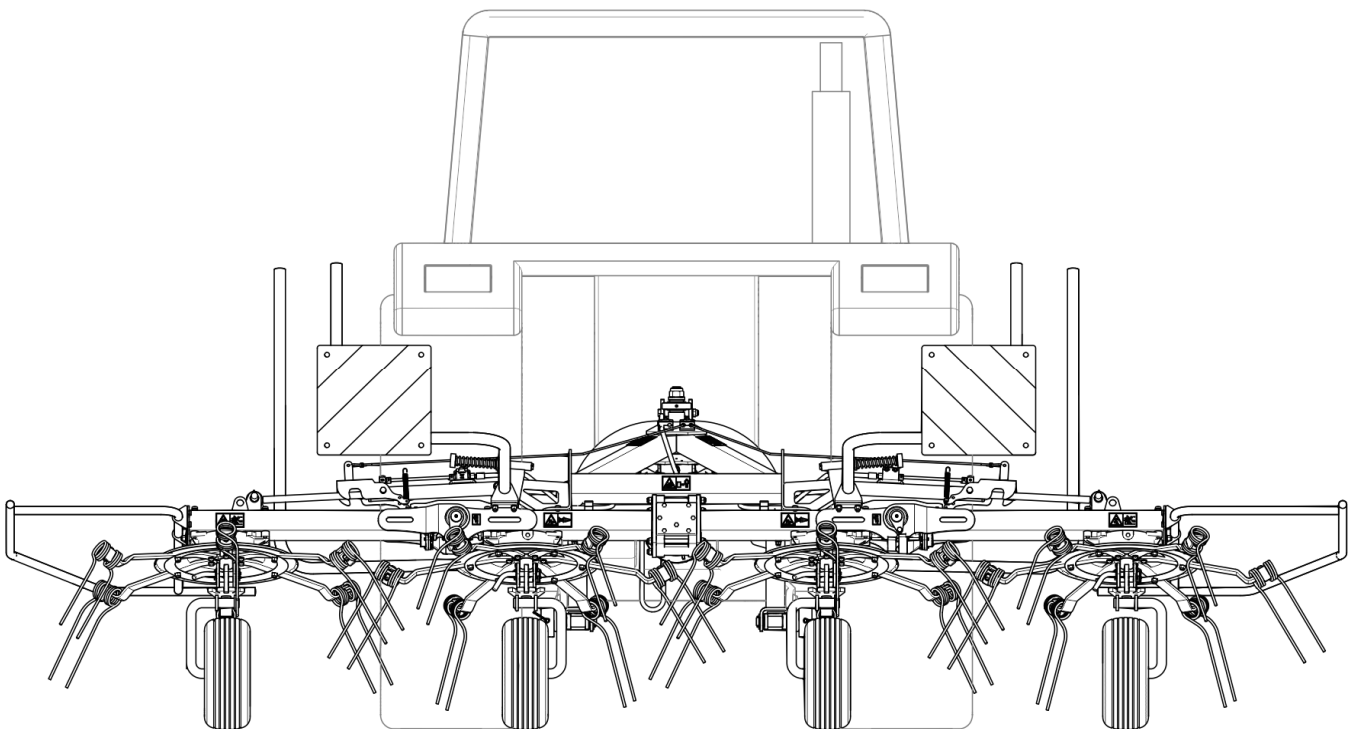

FIGURE 4.5 Working position of the tedder.

In order to set the tedder from the transport position to the working position (FIGURE 4.5), perform the following actions:

- Stop the tractor and lower the tedder onto the support wheels.
- Immobilize tractor with parking brake.

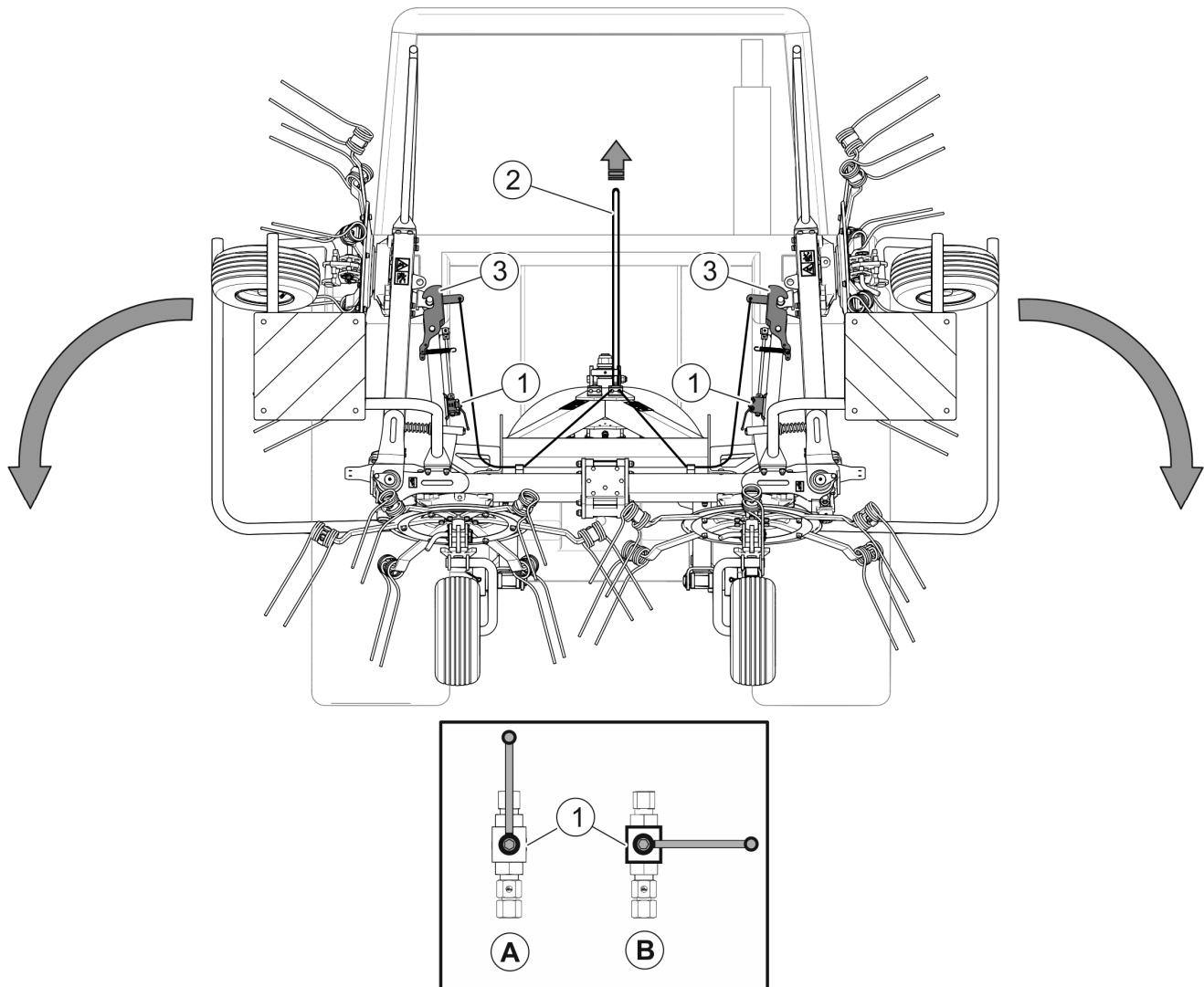

FIGURE 4.6 Setting the tedder to the working position.

(1) tilt cylinder valves, (A) OPEN position, (B) CLOSED position, (2) cable for releasing the cylinder lock, (3) mechanical locking of the cylinders

- Set the valves (1) of the tedder arm tilt cylinders to the "OPEN" position.
- While sitting in the tractor, from the operator's seat, set the lever of the hydraulic distributor to the LIFTING position, while simultaneously pulling and holding the cable (2) releasing the mechanical lock (3) of the hydraulic cylinders of the right and left outer rotor arms. After releasing the cylinder lock, slowly set the lever of the tractor hydraulic manifold controlling the cylinders to the LOWERING position.
- Lower the arms of the outer rotors until the road wheels touch the ground and release the cylinder lock cable. Set the control lever of the distributor to the FLOATING position, thanks to which the outer rotors will adjust to the ground unevenness.

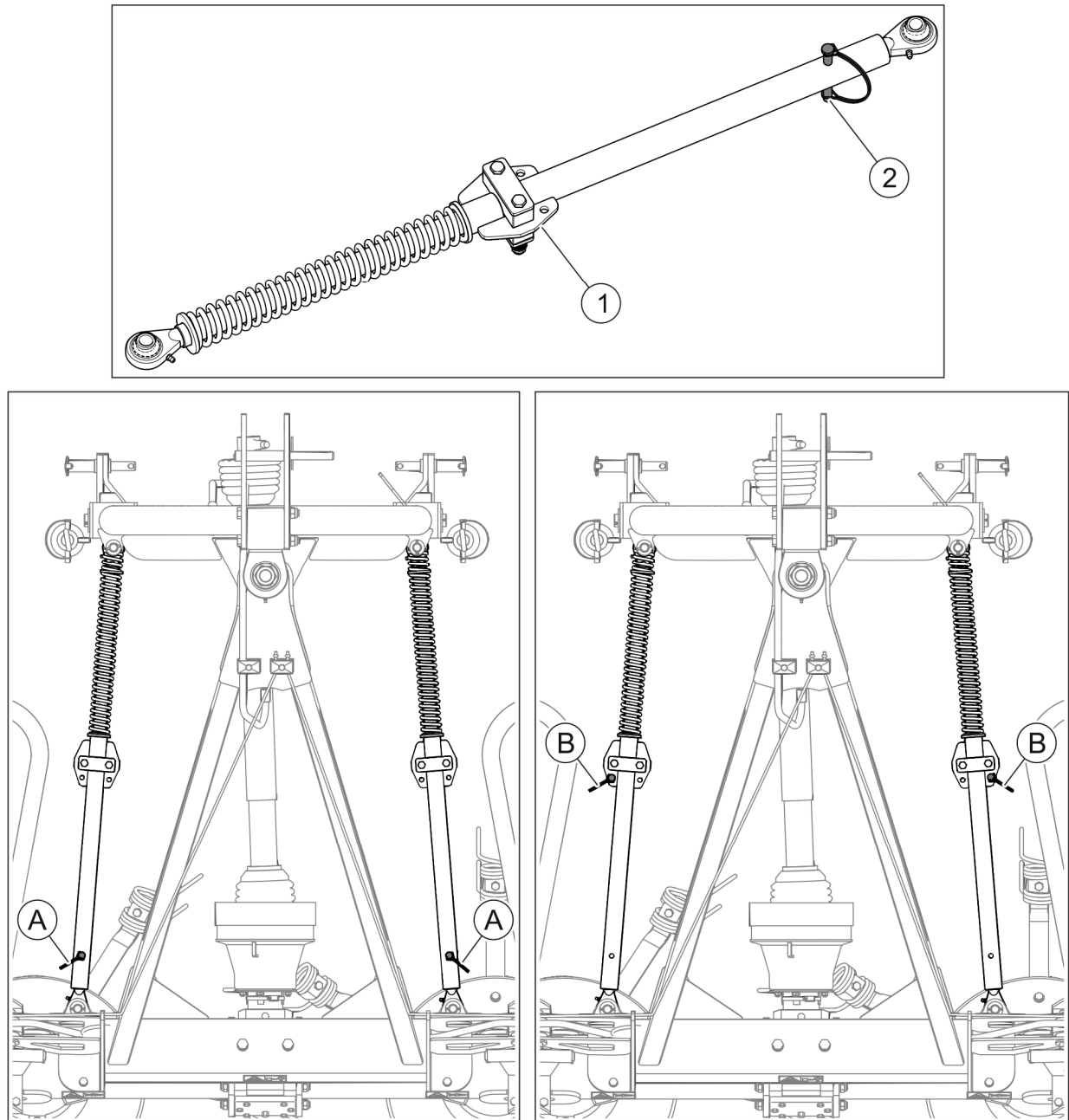

FIGURE 4.7 Move the vibration damper to the working position.

(1) vibration damper; (2) split pin; (A) the vibration damper in the locked position, (B) the vibration damper in the unlocked position

- Unlock the right and left tedder vibration damper by removing the locking pins (2) (FIGURE 4.7).

4.4.2 ADJUSTMENT OF THE WORKING POSITION

The correct working position of the tedder has a decisive influence on the quality of the teded material and the comfort of work.

One of the basic factors determining the correct setting of the machine is the correct height adjustment of the lower three-point linkage of the tractor. Their height is regulated with hangers. Both links must be at the same height, otherwise the tedder may be tilted to the left or right side. This operation should be performed before hitching the tedder to the tractor.



CAUTION

Refer to the principles of three-point linkage adjustment in the tractor operator's manual.

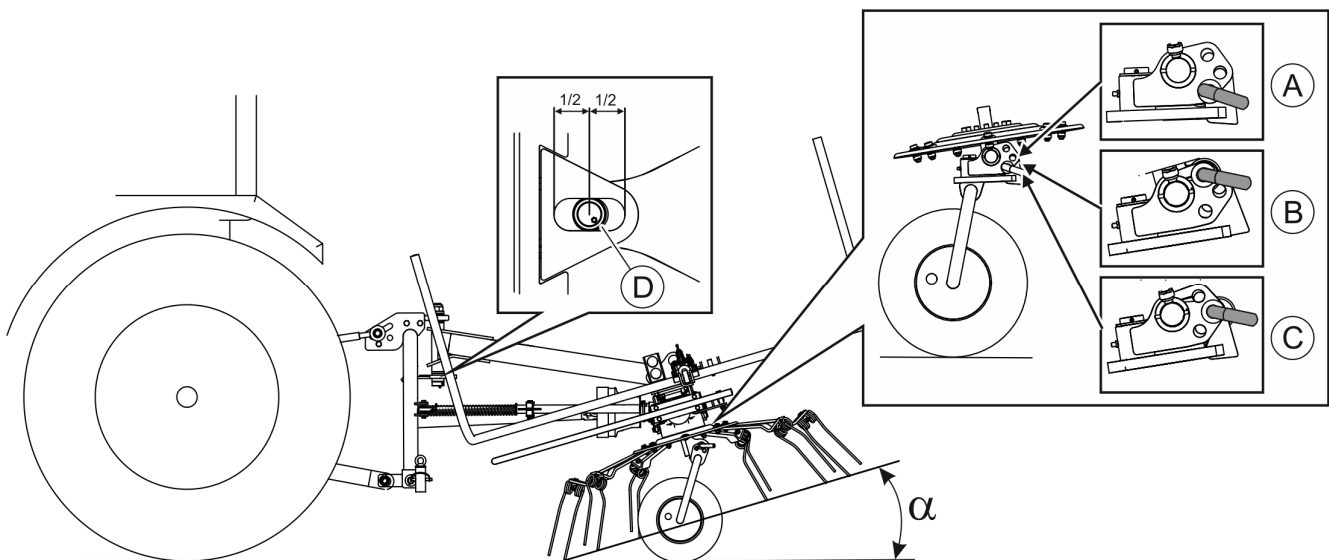



FIGURE 4.8 Tedder operation - rotor inclination angle (spreading angle).

(α) spreading angle, (A) large spreading angle, (B) small spreading angle, (C) normal spreading angle, (D) position of the sleeve in the hole



DANGER

Adjustment of the working height and spreading angle of the tedder must be performed with the tractor engine switched off. The key should be removed from the ignition switch and the tractor should be secured against unauthorized access. The tractor must be braked with the parking brake.

Adjustment of the working position should be made after lowering the machine to the ground. The working position of the tedder should be adjusted by following the steps below:

- place the tractor and tedder on flat, level ground,

- set the operating mode of the rear three-point linkage to the adjustment position,
- set the height of the lower links of the tractor's three-point linkage and adjust the length of the upper link in such a way that the rotors lean forward and the spring fingers lightly touch the ground, and the joint sleeve is in the central part of the long hole (D) (FIGURE 4.8),

After adjusting the tractor's rear three-point linkage, set the swath spreading angle. To do this:

- place the tractor and tedder on flat, level ground,
- raise the tedder to the minimum height enabling the support wheels to swing out,
- support the machine to prevent it from falling
- move the pins blocking the position of the wheels to the desired angle of inclination (A), (B) or (C) (FIGURE 4.8) and secure them with cotter pins
- lower the machine onto support wheels.

lower the machine onto support wheels. The selection of the height and the angle of the rotor inclination depends on the amount of cut swath, the degree of humidity, the assumed tedding speed and the ground on which the tedder will move. If the tine clearance is too high, there is a risk that less than the swath will be tossed. At a low setting, the swath may be contaminated with torn-out soil, turf, stones, etc. moreover, the risk of damage to the tedder, especially the spring fingers and their attachment to the arm, increases. The selection of the height should be checked on an ongoing basis during the operation of the tedding unit and, if necessary, you have to correct the setting.

If the height of the tedding fingers is incorrect, correct the height setting of the lower forks of the three-point linkage, the length of the linkage and adjust the height of the tedding unit again.

4.4.3 TEDDER WORK

DANGER



The rotary tedder may be started only when all guards and frames securing the tedder are properly attached and the tedder is set to the working position.

Before moving off make sure that there are no bystanders, especially children, near the tedder and tractor. Ensure adequate visibility of the machine during operation.

Bystanders should stay at a safe distance (at least 50 meters) from the tedder during operation due to the risk of objects (stones, branches) being thrown out from under the tedding fingers.



DANGER

Never exceed the PTO speed of 540 rpm. Otherwise, the tedder's drive system may be damaged.

After connecting the rotary tedder with the agricultural tractor and setting it to the working position, we can start to start the machine.

Engage the rear PTO drive in the agricultural tractor at a suitably low engine speed, and then gradually increase it until the PTO speed is 540 rpm. After obtaining the appropriate revolutions of the tractor PTO shaft, we can start work.

During work, the tractor operator is obliged to ensure proper visibility of the machine and the working area in order to be able to see any obstacles and possible danger on the way of the working tedder.

The recommended operating speed is 10 km/h or less. The swath may not be shaken properly at higher speeds. The permissible speed of the articulated telescopic shaft is 540 rpm however the recommended speed is about 500 rpm. For drier swaths, an even greater reduction of the PTO speed is recommended.

The rotational speed of the roller and the speed of travel depends on several factors, including the size of the swath, the degree of humidity, the length of the swath, the topography, therefore the selection of appropriate operating parameters is the obligation of the tedder operator. When the machine is in operation, the tractor's three-point linkage system should be set to the positional adjustment mode, and the tedder units tilting cylinders should be set to the FLOATING position.

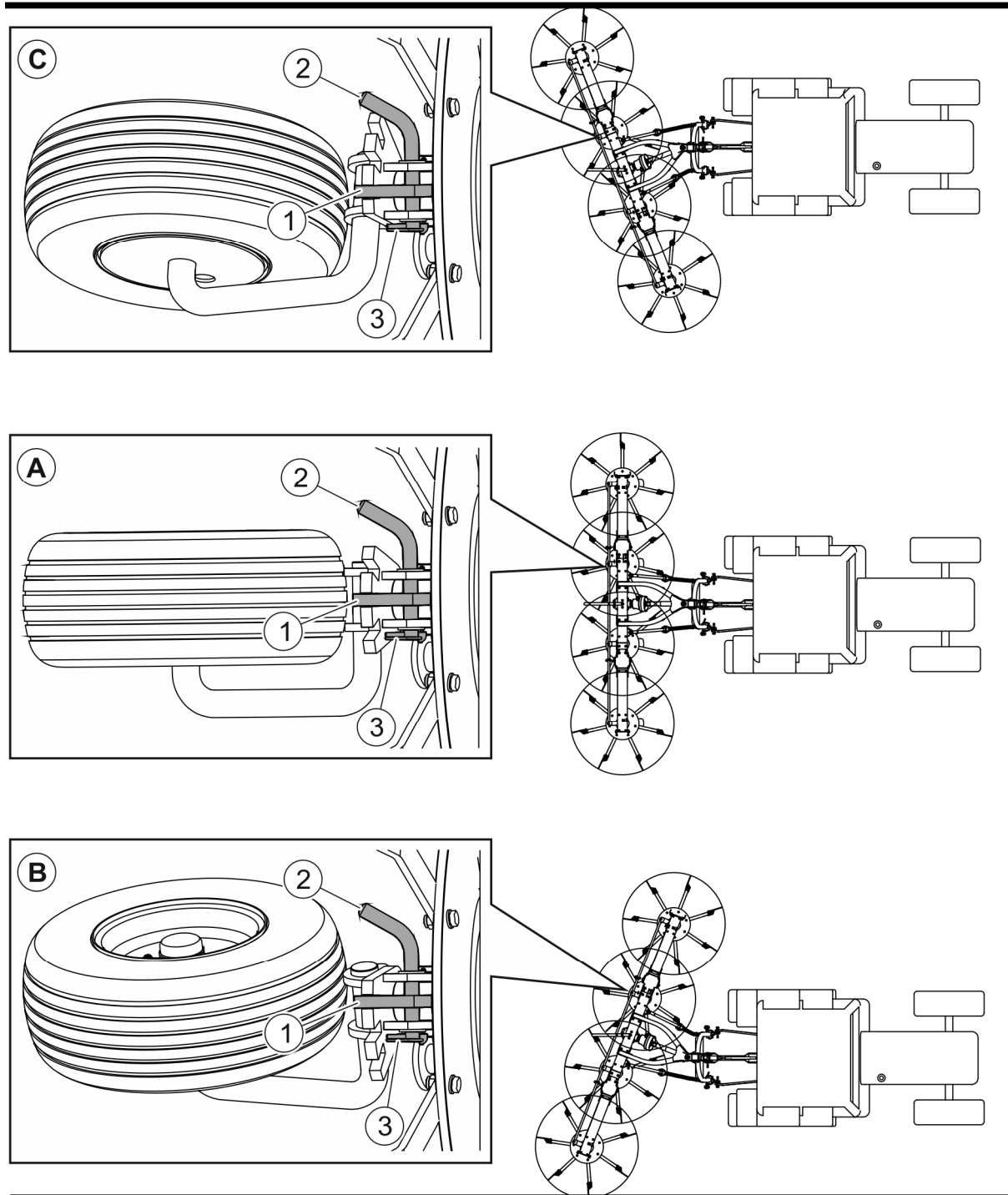

FIGURE 4.9 Tedder operation - border tending (along the edge of the field)

(1) support for road wheel deflection adjustment; (2) a locking pin; (3) split pin;

(A) middle tending, (B) right side tending, (C) left side tending

During boundary tending (along the field edge), adjust the deflection of all road wheels (FIGURE 4.9). When operating the tedder at the right edge of the field, all road wheels should be swiveled to the right (B), when working at the left edge of the field, all road wheels

should be swiveled to the left (C). When working in the middle of the field, set all road wheels in the middle position (A). Moving the wheels should be performed after raising the machine to the minimum height and removing the locking pin (2) of the road wheel in the desired position.

During turns or reversing, the tractor PTO drive should be disengaged and the tedder should be raised using the three-point linkage.

4.5 DISCONNECTING THE TEDDER FROM THE AGRICULTURAL TRACTOR



DANGER

Disconnect the tedder from the tractor only on flat and stable ground.

In order to disconnect the tedder from the tractor, perform the following steps (FIGURE 4.1):

- lower the tedder to the rest position using the tractor's three-point linkage, so that it rests on the road wheels,
- turn off the tractor engine and remove the key from the ignition switch,
- immobilize the tractor and secure it against rolling,
- lower the left and right supports (4) of the tedder and secure them with cotter pins,
- disconnect the articulated telescopic shaft (8),
- disconnect the hydraulic conduit (6) of the tedder from the tractor quick coupler,
- disconnect the upper link (C) of the tractor's three-point linkage from the upper point (3) of the tedder linkage mounting,
- disconnect the lower pins (1) and (2) of the tedder linkage from the lower links (A) and (B) of the tractor's three-point linkage
- start the tractor and drive the tractor away from the tedder.

4.6 LIGHTING INSTALLATION AND ADDITIONAL MARKING (OPTIONAL)

4.6.1 CONSTRUCTION

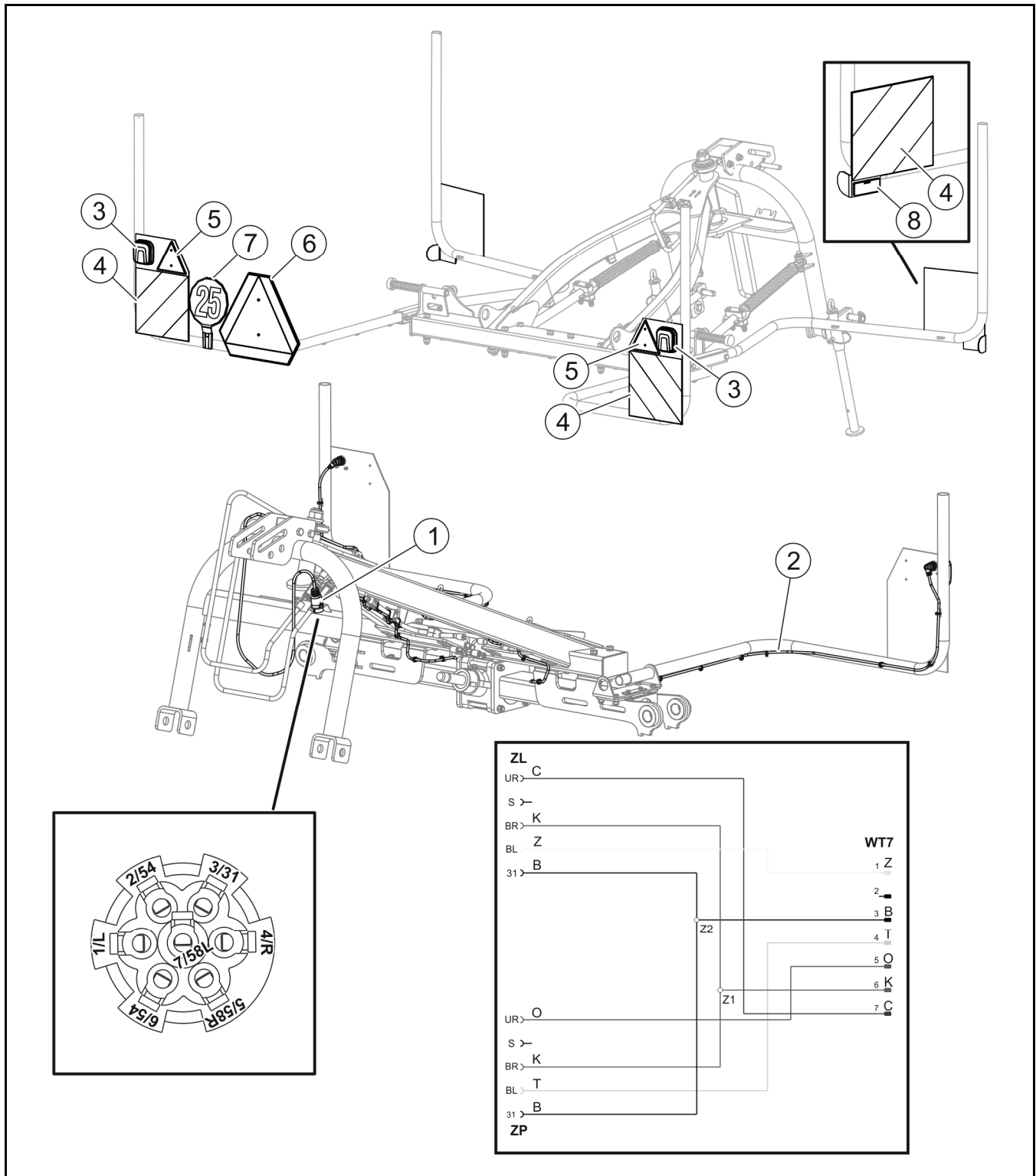

FIGURE 4.10 Lighting installation and additional marking.

1) 7-pin electric plug, (2) central harness, (3) combination rear lamps, (4) contour marking, (5) reflective triangle DOB-31 (option), (6) TW-11 slow-moving vehicle sign (option), (7) 25 km/h sticker (option), (8) DOB-35 white rectangular reflector (option)

TABLE 4.1 MARKINGS OF CONNECTION SOCKET

MARKING	FUNCTION
3/31	Weight
2/54	Not used
1/L	Left direction indicator
6/54	STOP light
7/58L	Rear left position light
5/58R	Rear right position light
4/R	Right direction indicator

TABLE 4.2 COLOUR CODING OF WIRES

MARKING	FUNCTION
b	White
c	Black
f	Purple
k	Red
l	Azurite
n	Blue
o	Brown
p	Orange
r	Pink
s	Grey
t	Green
z	Yellow

TABLE 4.3 ELECTRICAL ELEMENTS MARKINGS

MARKING	FUNCTION
WT7	7-pin plug
ZP	Multifunctional rear right lamp
ZL	Multifunctional rear left lamp

4.6.2 USAGE AND MAINTENANCE

The power supply to the lighting system of the machine requires the electrical installation of a tractor with a voltage of 12V with a 7-pin electrical outlet.



CAUTION

Driving with defective lighting installations is prohibited. Damaged lamps should be replaced immediately before driving off. Lost or damaged reflectors should be replaced with new ones.

Before travelling, make sure that all lamps and reflectors are clean.

Works related to the repair, replacement or regeneration of electrical installation components should be entrusted to specialized workshops that have appropriate technologies and qualifications to perform this type of work.

Your duties include only technical inspection of the electrical installation and reflectors.

The scope of service activities

1. Connect the lighting system of the machine to the tractor with a suitable electrical outlet.



CAUTION

If the tractor does not have the correct sockets or if the sockets are of a different type, have them installed by qualified personnel.

2. Check the completeness, technical condition and correct functioning of the machine lighting.
3. Check the tractor connection socket and the cable plug on the machine.



CAUTION

A damaged body of the socket or plug of the electric cord qualifies for replacement.

4. Check the the wiring harness for damage (rubbed insulation, wire break, etc.).
5. Check the mounting of the SMV triangular plate and its bracket.

Before travelling on a public road, make sure that the tractor has a reflective warning triangle.

CHAPTER

5

TECHNICAL SUPPORT

5.1 TECHNICAL INSPECTION

When preparing the tedder for use, check individual elements in accordance with the guidelines presented in Table 4.1.

TABLE 5.1 TECHNICAL INSPECTION SCHEDULE

DESCRIPTION	SERVICE ACTIVITIES	REVIEW PERIOD
The correctness of mounting the tedder to the tractor suspension system	Check if it is properly mounted	Every day before starting work
Condition of guards and protective frames	Check the technical condition of shields and frames, their completeness and correctness of fastening.	
Condition of road wheels and air pressure in the tires	Check the technical condition of the tires (tread, side surfaces), check and, if necessary, inflate the wheel to the recommended pressure	
The technical condition of the hydraulic system	Check according to chapter "5.4 <i>HYDRAULIC SYSTEM OPERATION</i> "	
Check the level of lubricating oil in the main gear	Check according to chapter "5.3 <i>OPERATION OF THE MAIN GEAR</i> "	
The tightening condition of the most important screw connections	The tightening torque should be in accordance with the Table 5.3	
Correct mounting of the tedder's spring fingers to the arms and the arms to the rotor	Make sure fingers are properly tightened.	
Lubrication	Lubricate the components according to the Chapter "5.5 <i>LUBRICATION</i> ".	
Oil change in the main gear	Replace according to chapter "5.3 <i>OPERATION OF THE MAIN GEAR</i> "	After the first 50 hours, then every 500 hours or once a year



CAUTION

It is forbidden to use an inoperative rotary tedder.

5.2 INSPECTION AND REPLACEMENT OF THE SPRING FINGERS



DANGER

Before starting work, turn off the tractor engine, remove the key from the ignition switch and brake the tractor with the parking brake. The tractor must be secured against unauthorized access.

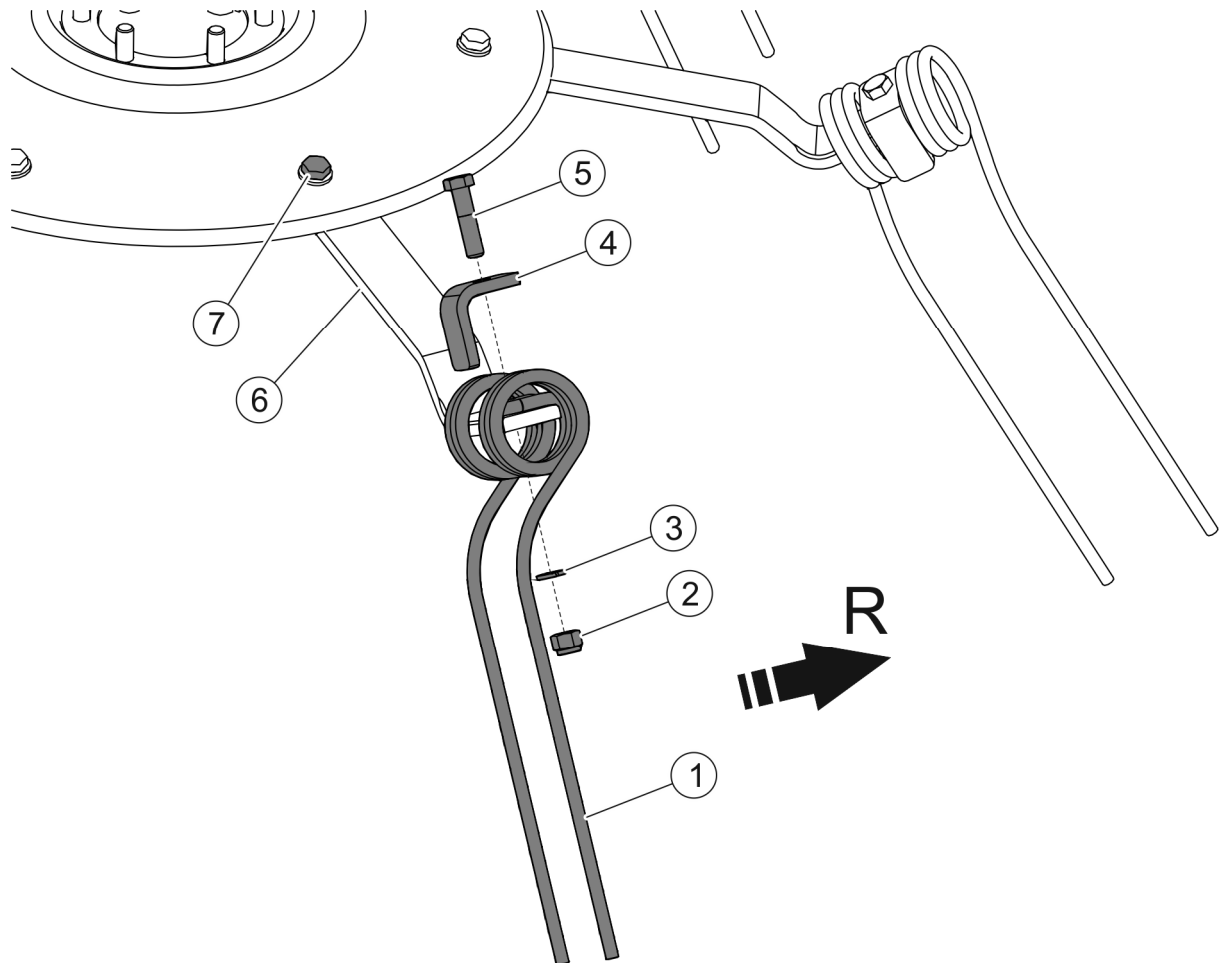



FIGURE 5.1 Spring fingers replacement.

(1) spring pin, (2) self-locking nut, (3) washer, (4) fastening element, (5) screw fastening the finger to the arm, (6) rotor arm, (7) screw fastening the arm to the rotor, (R) the rotational direction of the rotor.

In order to dismantle the spring fingers:

- unscrew the lock nuts (2)
- remove the fastening element (4) and the bolt (5)
- remove the damaged spring finger (1) from the arm (6) and install a new one,

- mount the bolt (5) and the fastening element (4) and tighten the nut (2) with the appropriate torque



CAUTION

When fitting the fingers, pay attention to the direction of rotation (R) of the rotor.

Spring fingers and their mounting should be checked on an ongoing basis during the tedder's operation. Damaged components must be replaced with new ones. Spring fingers cannot be repaired.



After a day's work with the tedder, check the condition of the spring fingers connections to the arm and the arms to the rotor.

5.3 OPERATION OF THE MAIN GEAR

Main gear maintenance comes down to general inspection, replacement or topping up of gear oil losses. In the event of damage to the gearbox, contact an authorized service point for repair.

The first oil change must be made after the first 50 hours of operation. Subsequent oil changes should be performed after 500 hours of tedder operation or once a year. The time of preparation for the first field works is the most favourable period for changing the gear oil. The amount of oil needed to fill the gearbox is 1.2 litres. Required gear oil: SAE90EP.

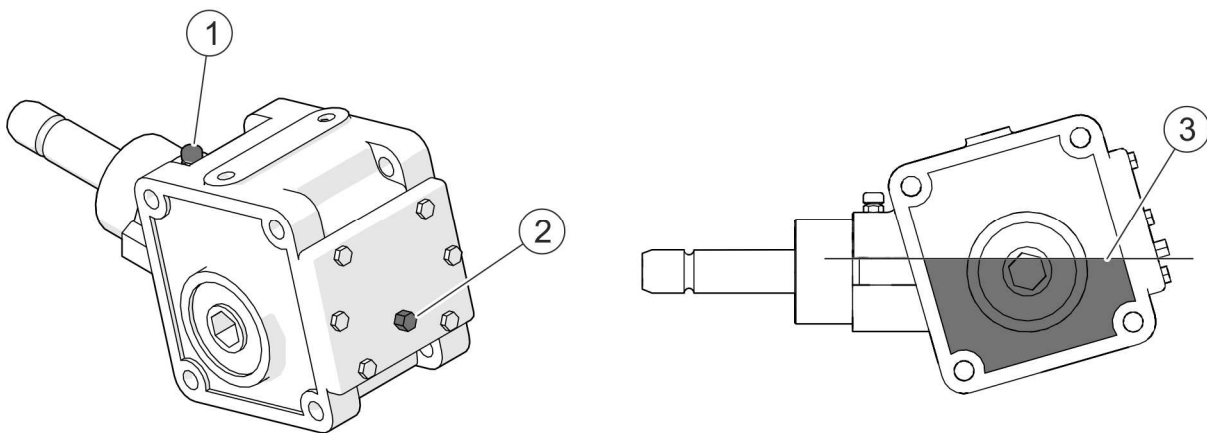

FIGURE 5.2 Transmission oil change.

(1) filler plug, (2) inspection and drain plug, (3) correct oil level

In order to change the oil in the main gear:

- set the tedder on hard ground and tilt the machine to the rear as far as possible,
- unscrew the filler plug (1),
- unscrew the inspection and drain plug (2) at the rear part of the reducer,
- drain the oil into a sealed container made of oil-resistant material, the capacity of the tank should be about 3 litres,
- level the machine
- pour oil through the filler plug (1) until it overflows through the inspection and drain plug (2),
- screw on the inspection and drain plug (2),
- screw on the filler plug (1).



The first oil change should be made after 50 hours of tedder operation, and the next change after 500 hours or a year of operation.

If you notice a leak, check the seal carefully and check the oil level. Operating of the gearbox with a low oil level may lead to permanent damage to its mechanisms.

Repair of the gear during the warranty period may be performed only by specialized mechanical workshops.

5.4 HYDRAULIC SYSTEM OPERATION



DANGER

Before starting any work on the hydraulic system, reduce pressure in the system.



DANGER

When working on the hydraulic system, use appropriate personal protective equipment, i.e. protective clothing, shoes, gloves, glasses. Avoid oil contact with skin.

It is absolutely necessary to observe that the oil in the tedders hydraulic system and the tractor's hydraulic system must be of the same type. The use of different types of oil is not allowed. The hydraulic system in a new tedder is filled with AGROL U hydraulic oil.



CAUTION

The technical condition of the hydraulic system should be inspected on an ongoing basis while the is in use.

The hydraulic system should be completely tight. When the hydraulic cylinders are fully extended, the seals should be checked. In the event of oiling on the hydraulic cylinder body, the nature of the leakage must be checked. Slight leaks are permissible with symptoms of "sweating", however in the event of noticing leaks in the form of "droplets" stop using the machine until the fault is remedied.

In the event of confirmation of an oil leak on hydraulic conduit connections, tighten connections, and if this does not remedy faults then replace conduit or connection elements with new ones. Also any mechanical damage of a component requires the replacement with a new one. Also, make sure that the hydraulic hoses are not kinked.



Flexible hydraulic hoses should be replaced every 4 of the machine use.

The oil used, due to its composition, is not classified as a dangerous substance, however long-term effects on the skin or eyes may cause irritation. In the event of contact of oil with skin, wash the area of contact with water and soap. Do not use organic solvents (petrol, kerosene). Soiled clothing should be removed to prevent oil from getting on your skin. If the

oil gets into your eyes, flush them with plenty of water and in case of irritation contact your doctor. Hydraulic oil under normal conditions is not harmful to the respiratory tract. The hazard only occurs when the oil is strongly atomized (oil mist), or in the event of a fire during which toxic compounds may be released. Oil should be extinguished with carbon dioxide (CO₂), foam or extinguishing steam. Do not use water to extinguish a fire.

Spilled oil should be immediately collected and placed in a marked, sealed container. Used oil should be taken to an oil disposal or regeneration point.

TABLE 5.2 AGROL U HYDRAULIC OIL CHARACTERISTICS

ITEM	NAME	UNIT	VALUE
1	Kinematic viscosity at 100°C	-	10.0- 11.5
2	Viscosity index, min.		>95
3	Pour point, max.	°C	<-24
4	Base number mgKOH/g	-	9.9
5	Flash-point	°C	>230

5.5 LUBRICATION



When using the machine, the user is obliged to follow the lubrication instructions in accordance with the prescribed schedule. The excess of lubricant will cause the deposition of additional contaminants on the places requiring lubrication, therefore it is necessary to keep the individual machine elements clean.

All grease nipples located on the machine, in places marked with the lubrication pictogram, are subject to lubrication. These locations are shown in Figure 5.3 and detailed in Table 5.3.

The machine should be lubricated with a manually or foot operated grease gun, filled with permanent grease. If possible, remove old grease and other contaminants before starting lubrication. Wipe off excess grease.

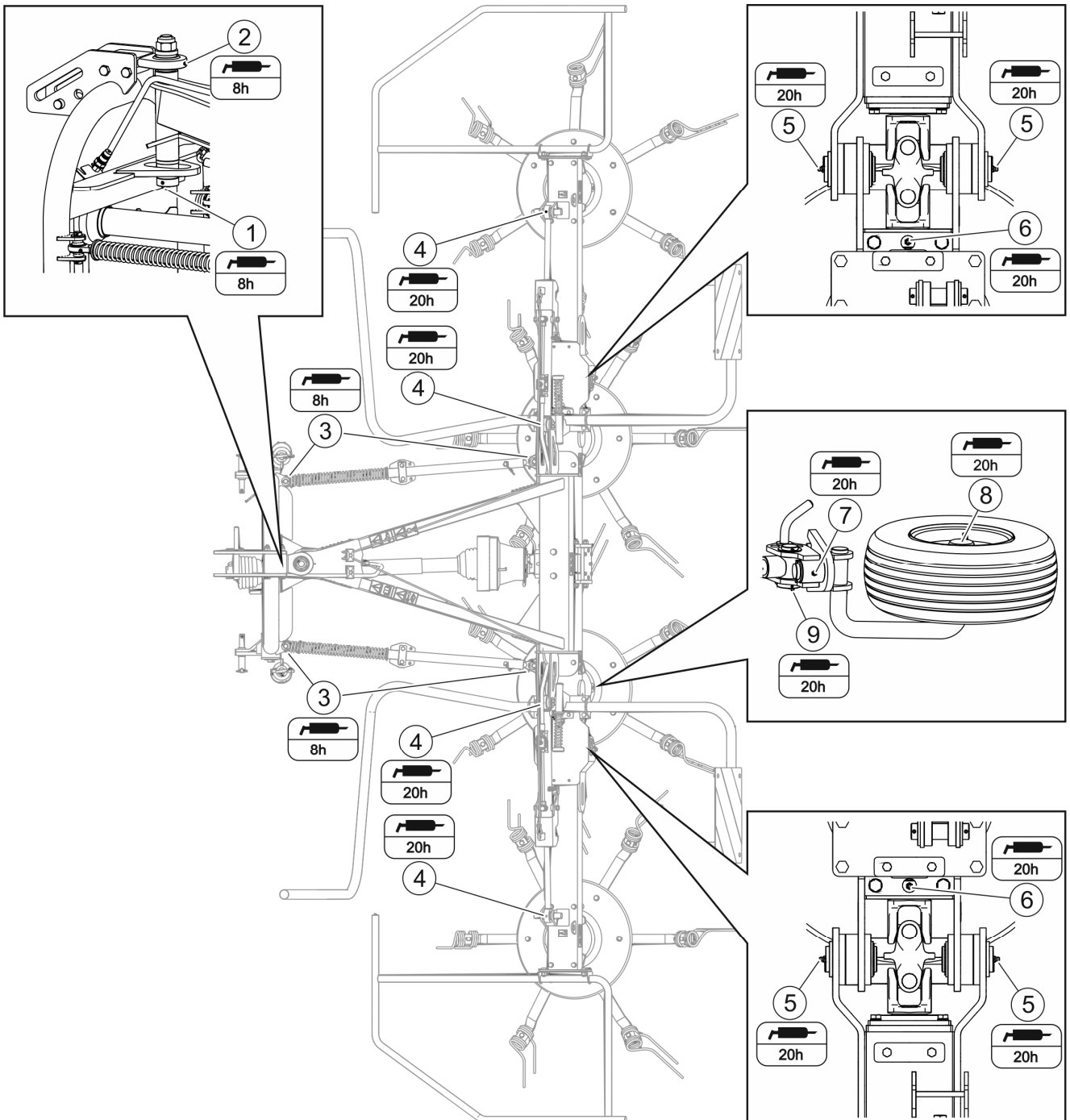

FIGURE 5.3 Location of the tedder lubrication points.

TABLE 5.3 Lubrication point

ITEM	NAME	NUMBER OF LUBRICATION POINTS	TYPE OF LUBRICANT	LUBRICATION FREQUENCY
1	Rotor ring	1	SOLID	Every 8 hours
2	Ball joint of the frame suspension	1	OIL	Every 8 hours
3	Ball joint of the vibration damper	2	OIL	Every 8 hours
4	Tilt cylinder piston rod eye	2	SOLID	Every 20 hours
5	Swivel arm rotation axis	4	SOLID	Every 20 hours
6	Rotor drive shaft joint	4	SOLID	Every 20 hours
7	Road wheel bracket axle	4	SOLID	Every 20 hours
8	The axis of rotation of the road wheel	4	SOLID	Every 20 hours
9	Road wheel bracket axle	4	SOLID	Every 20 hours
10	PTO shaft★			

CAUTION The description of the markings from the Item column in Table 5.3 is consistent with the numbering presented in Figure 5.3.

★ Lubrication of the articulated telescopic shaft should be performed according to the manufacturer's recommendations. For detailed information on operation maintenance, refer to the operating instructions supplied with the shaft.

5.6 SCREW CONNECTIONS TIGHTENING

Before each use of the machine and during maintenance and repair work, check the tightness of all screw connections. In the event of any clearance in bolted connections, tighten the bolt with the appropriate torque (TABLE 5.4), unless other tightening parameters are given. Recommended torques apply to non-lubricated steel bolts.



CAUTION

If it is necessary to replace individual parts, use only original parts or those indicated by the Manufacturer. Non-adherence to these requirements may put the user and other people's health and life at risk, and also damage the machine.

TABLE 5.4 TIGHTENING TORQUE FOR NUT AND BOLT CONNECTIONS

THREAD DIAMETER [mm]	5.8	8.8	10.9
	Tightening torque [Nm]		
M6	8	10	15
M8	18	25	36
M10	37	49	72
M12	64	85	125
M14	100	135	200
M16	160	210	310
M20	300	425	610
M24	530	730	1050
M27	820	1150	1650
M30	1050	1450	2100
M32	1050	1450	2100

5.7 STORAGE

After finishing work, the rotary tedder should be carefully cleaned and washed with a water jet. During washing, do not direct a strong stream of water or steam at information and warning stickers, bearings. The nozzle of a pressure or steam washer should be kept at a distance of not less than 30 cm from the cleaned surface.

After cleaning the tedder, inspect the entire machine and inspect the technical condition of individual elements. Worn or damaged elements should be repaired or replaced with new ones.

In the event of damage to the paint coating, clean the damaged places of rust and dust, degrease, and then paint with a primer paint and, after drying, with a surface paint, maintaining the uniform colour and uniform thickness of the protective coating. Until painting, the damaged places can be covered with a thin layer of grease or an anti-corrosion agent. It is recommended that the equipment be stored indoors or under a roof.



DANGER

The tedder should be stored only with unfolded side rotors modules in the working position (danger of tipping).

If the tedder is not going to be used for a longer period of time, it is necessary to protect it against the influence of weather conditions, especially those that cause steel corrosion and accelerate tire aging. Cylinder piston rods should be cleaned and conserved with grease.

The tedder should be lubricated in accordance with the recommendations. In the event of a longer stop, it is necessary to lubricate all components regardless of the period of the last treatment. Additionally, before the winter period, the pins of the hitching system should be lubricated.

Tires should be maintained at least twice a year with the use of appropriate preparations intended for this purpose. Complete wheels should be thoroughly washed and dried beforehand. During longer storage of the unused tedder, it is recommended to move the machine every 2-3 weeks in such a way that the place of contact of the tire with the ground is in a different position. The tires will not deform and will maintain proper geometry. You should also check your tire pressure from time to time, and if necessary, inflate the wheels to the correct value.

5.8 FAULTS AND HOW TO REMOVE THEM

TABLE 5.5 FAULTS AND HOW TO REMOVE THEM

TYPE OF FAULT	CAUSE	REMOVAL METHOD
It is not possible to set the tedder to the working position by means of the tipping cylinders	Incorrectly connected or damaged quick couplers	Check the quick couplers and the way of connection
	The tractor's hydraulic system is not working properly	Check the condition of the tractor's hydraulic system
Excessive vibration during operation	Rotor drive shaft damaged	Check the shaft and replace if necessary
	Damaged articulated telescopic shaft	Check the shaft and replace if necessary
Excessive heating of the bevel gear	Incorrect oil level	Check oil level.
	Damaged bearings	Repair with service help
The tedder rotors stopping during operation	Rotor drive shaft damaged	Check the shaft and replace if necessary
	Damaged articulated telescopic shaft	Check the shaft and replace if necessary
	Damaged gearbox	Repair with service help

NOTES

A series of horizontal dotted lines for writing notes.

