



PRONAR SP. Z O.O.

17-210 NAREW, UL. MICKIEWICZA 101A, PODLASKIE PROVINCE

PHONE: +48 085 681 63 29

+48 085 681 64 29

+48 085 681 63 81

+48 085 681 63 82

FAX: +48 085 681 63 83

+48 085 682 71 10

www.pronar.pl

OPERATOR'S MANUAL

SNOW PLOUGH

PRONAR PUV-1800M / PUV-2000M

TRANSLATION OF THE ORIGINAL COPY OF THE MANUAL

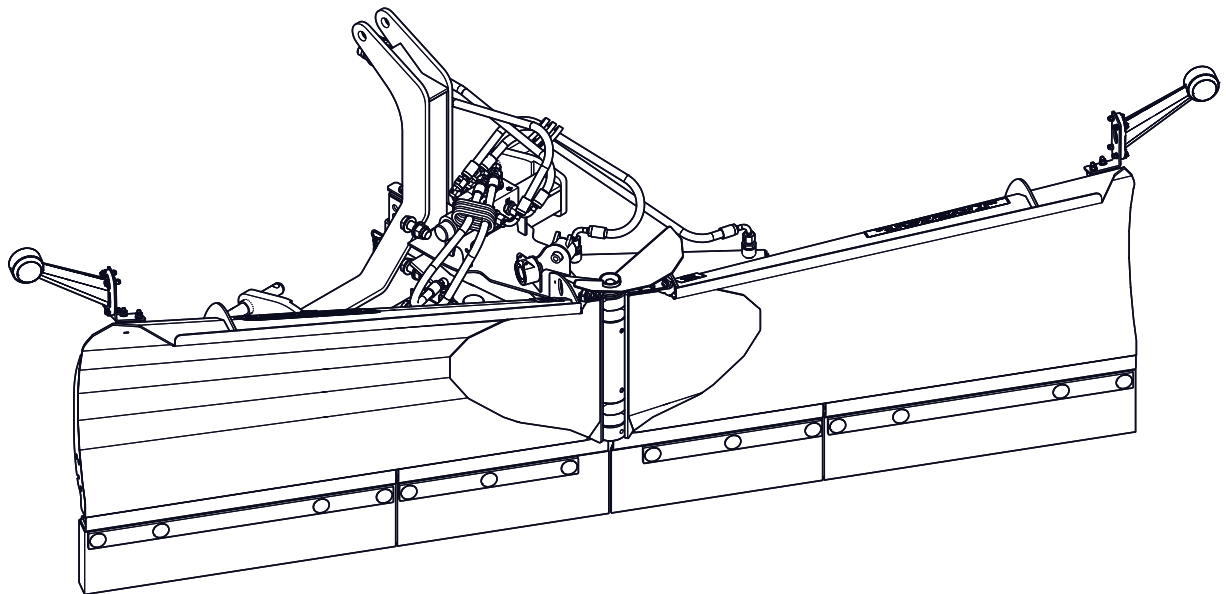

EDITION: 1B-11-2017

PUBLICATION NO.: 569N-00000000UM



INTRODUCTION

1.2 SYMBOLS APPEARING IN THIS OPERATOR'S MANUAL

DANGER

Information, descriptions of danger and precautions as well as recommendations and prohibitions associated with the safety of use are marked in the text with the sign **DANGER**. Failure to observe the instructions may endanger the machine operator's or other person's health or life.



ATTENTION

Particularly important information and instructions, the observance of which is essential, are distinguished in the text by the sign **ATTENTION**. Failure to observe the instructions may lead to damage to the machine as a result of improper operation, adjustment or use.



TIP

Additional tips included in the Operator's Manual describe useful advice for the machine operation and are marked with the sign **TIP**.

In order to focus the user's attention on

the need to perform maintenance, the rel-



evant section of the Operator's Manual is marked with the clock pictogram.

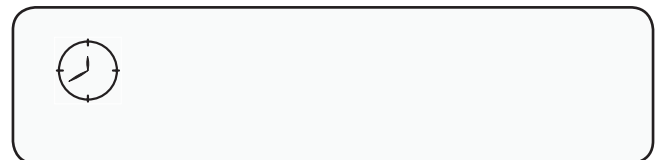

DIRECTIONS USED IN THIS OPERATOR'S MANUAL

Left side – side to the left hand of the operator facing in the direction of machine's forward travel.

Right side – side to the right hand of the operator facing in the direction of machine's forward travel.

Rotation to the right – clockwise rotation of a mechanism (the operator is facing the mechanism).

Rotation to the left – counterclockwise rotation of a mechanism (the operator is facing the mechanism).

B.2.2.569.02.1.EN



PRONAR Sp. z o.o.

ul. Mickiewicza 101 A
17-210 Narew, Polska

tel./fax (+48 85) 681 63 29, 681 63 81, 681 63 82,
681 63 84, 681 64 29

fax (+48 85) 681 63 83

<http://www.pronar.pl>

e-mail: pronar@pronar.pl

EC DECLARATION OF CONFORMITY OF THE MACHINERY

PRONAR Sp. z o.o. declares with full responsibility, that the machine:

Description and identification of the machinery		
Generic denomination and function:	Snow plough	
Type:	PUV-1800M	PUV-2000M
Model:	—	—
Serial number:		
Commercial name:	Snow plough PRONAR PUV-1800M Snow plough PRONAR PUV-2000M	

to which this declaration relates, fulfills all the relevant provisions of the Directive **2006/42/EC** of The European Parliament and of The Council of 17 May 2006 on machinery, and amending Directive 95/16/EC (Official Journal of the EU, L 157/24 of 09.06.2006).

The person authorized to compile the technical file is the Head of Research and Development Department at PRONAR Sp. z o.o., 17-210 Narew, ul. Mickiewicza 101A, Poland.

This declaration relates exclusively to the machinery in the state in which it was placed on the market, and excludes components which are added and/or operations carried out subsequently by the final user.

Narew, the 2018-09-03

Place and date

*Full name of the empowered person
position, signature*

TABLE OF CONTENTS

INTRODUCTION

1.1	INTRODUCTION	2
1.2	SYMBOLS APPEARING IN THIS OPERATOR'S MANUAL	3

BASIC INFORMATION

1.1	IDENTIFICATION	1.2
1.2	PROPER USE	1.3
1.3	EQUIPMENT	1.5
1.4	TERMS & CONDITIONS OF WARRANTY	1.6
1.5	TRANSPORT	1.7
1.6	ENVIRONMENTAL HAZARDS	1.10
1.7	WITHDRAWAL FROM USE	1.11

SAFETY ADVICE

2.1	PRINCIPLES OF SAFETY WHEN USING THE MACHINE	2.2
2.2	SAFETY WHEN HITCHING THE MACHINE	2.3
2.3	SAFETY RULES WHEN MAINTAINING THE HYDRAULIC SYSTEM	2.4
2.4	SAFETY DURING TRANSPORT TRAVEL	2.5
2.5	MAINTENANCE	2.6
2.6	SAFETY DURING SNOW PLOUGH OPERATION	2.8
2.7	RESIDUAL RISK	2.9
2.8	INFORMATION AND WARNING DECALS	2.10

DESIGN AND OPERATION

3.1	TECHNICAL SPECIFICATION	3.2
3.2	GENERAL DESIGN	3.4
3.3	HYDRAULIC SYSTEM	3.5
3.4	ELECTRICAL SYSTEM	3.9

CORRECT USE

4.1	PREPARING FOR WORK	4.2
4.2	TECHNICAL INSPECTION	4.4
4.3	HITCHING TO VEHICLE	4.5
4.4	SNOW PLOUGH OPERATION	4.8
4.5	DRIVING ON PUBLIC ROADS	4.12
4.6	UNHITCHING THE MACHINE FROM CARRYING VEHICLE	4.13

MAINTENANCE

5.1	CHECKING AND REPLACEMENT OF COLLECTING BLADES	5.2
5.2	REPLACEMENT OF FENDERS	5.6
5.3	SLIDES REPLACEMENT	5.7
5.4	ADJUSTMENT OF COLLECTING BLADE SPRINGS	5.8
5.5	HYDRAULIC SYSTEM MAINTENANCE	5.10
5.6	ELECTRICAL SYSTEM MAINTENANCE	5.12
5.7	LUBRICATION	5.13
5.8	STORAGE	5.15
5.9	INSPECTION OF TIGHTENING TORQUE OF NUT AND BOLT CONNECTIONS	5.16
5.10	TROUBLESHOOTING	5.17

SECTION 1

BASIC INFORMATION

1.1 IDENTIFICATION

The snow ploughs are marked with data plate and serial number. The serial number is stamped into the data plate and on the left snow plough wing under the data plate. When buying the machine check that the serial numbers on the machine agree with the number written in the *Warranty Book*, in the sales documents and in the *Operator's Manual*.

The meanings of the individual fields found on the data plate are presented in the table below:

- A - machine name,
- B - machine type/symbol,
- C – serial number,
- D – year of manufacture,
- E – gross weight [kg],
- F – Quality Control stamp,
- G – machine name, name extension.

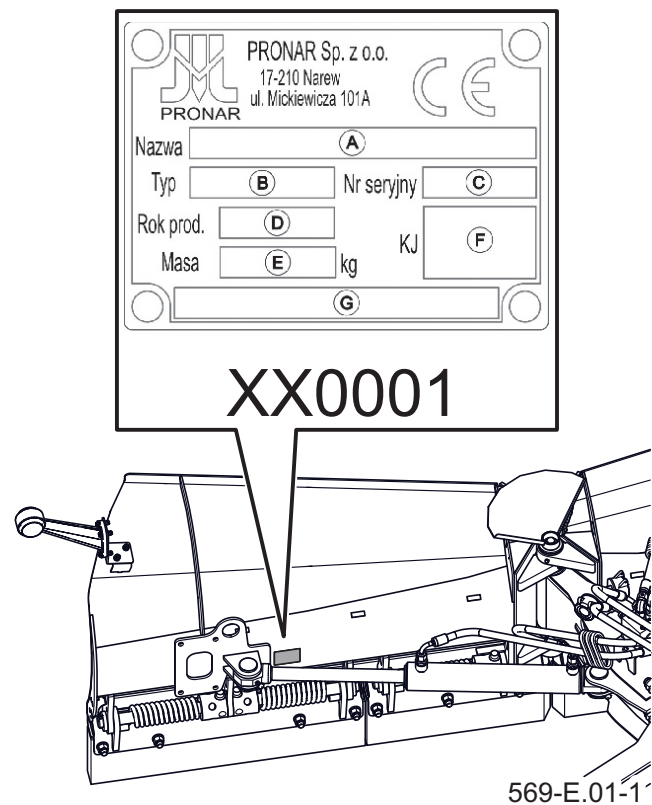

Figure 1.1 Location of the data plate and serial number

E.2.2.569.01.1.EN

1.2 PROPER USE

The snow ploughs are constructed according to current safety requirements and engineering standards.

The snow ploughs are designed for clearing road surfaces, squares, parking spaces and all other hard road and footpath surfaces such as asphalt, concrete paving blocks, paving, concrete. The use of the machine for other purposes should be regarded as improper. Depending on their equipment, the snow ploughs can be mounted on agricultural tractors, front loaders and other slow-moving vehicles that meet the requirements set out in Table 1.1.

Transporting people, animals or other materials is prohibited and regarded as contrary to the intended purpose. During the machine operation, comply with all road traffic regulations and transport regulations in force in the given country. Any breach of these regulations is regarded by the Manufacturer as the use contrary to the intended purpose of the machine.

Using it as intended involves all actions connected with the safe and proper operation and maintenance of the machine. Due to the above, the user is obliged to:

- carefully read the *Operator's Manual* and comply with its recommendations,

- understand the machine's operating principle and how to operate it safely and correctly,
- adhere to the established maintenance and adjustment plans,



ATTENTION

The machine must not be used for purposes other than those for which it is intended, in particular:

- levelling of roads, terrain;
- for transporting people and animals,
- for transporting whatever materials or objects.

- comply with general safety regulations while working,
- prevent accidents,
- comply with the road traffic regulations and transport regulations in force in the given country, in which the machine is used,
- carefully read the carrying vehicle's operator's manual and comply with its recommendations.

The machine may only be used by persons, who:

- are familiar with the contents of this publication and with the contents of the carrying vehicle Operator's Manual,
- have been trained in the snow plough

- operation and work safety,
- have the required authorisation to drive carrying vehicles and are

familiar with the road traffic regulations and transport regulations.

Table 1.1 Requirements for carrying vehicle

Contents	Unit	Requirements
Linkage Front three point linkage	-	Category 0/I according to ISO 730-1
Hydraulic system Hydraulic oil Nominal pressure of the system Hydraulic sockets	- MPa -	HL32 16 ÷ 20* socket-plug or plug-plug ISO 7241-1 type of one hydraulic section, - located on the carrying vehicle's front (depending on the snow plough version)
Electrical system Power supply of solenoid valve and clearance lights Electrical system voltage	- V	cigarette lighter socket (in the operator cab) 12
Other requirements Power range Beacon light	hp (kW) -	30 ÷ 50 (22 ÷ 37)* orange light**

*- optimum values are given; declared performance and durability of the machine are not guaranteed for other values.

** - not included in the snow plough equipment

E.2.2.569.02.1.EN

1.3 EQUIPMENT

The snow plough equipment includes:

- Operator's Manual,
- Warranty Book.

Equipment versions:

- vertical rubber snow plough blades (set at the angle of 90° to the ground, with or without bumpers),
- steel snow plough blades (set at the angle of 60° to the ground, with or without bumpers),
- vertical steel snow plough blades (set at the angle of 90° to the ground, with or without bumpers),
- perforated steel snow plough blades (set at the angle of 60° to the ground, with or without bumpers),
- hydraulic system without shock absorbers,
- hydraulic system with shock

- absorbers,
- independent control (individual control of each wing),
- independent-simultaneous control (individual control of each wing or simultaneous control),
- hydraulic system equipped with hydraulic socket and plug,
- hydraulic system equipped with two hydraulic conduit connectors,
- slides, support wheels or without support elements,
- rigid linkages,
- swinging linkages,
- without clearance lights,
- cigarette lighter socket - two-terminal network (to duplicate the cigarette lighter socket in the operator's cab).

E.2.2.569.03.1.EN

1.4 TERMS & CONDITIONS OF WARRANTY

PRONAR Sp. z o.o. Narew guarantees the reliable operation of the machine when it is used according to its intended purpose as described in the *Operator's Manual*. Defects discovered during the warranty period will be removed by the Warranty Service. The repair period is specified in the *Warranty Book*.

The warranty does not cover those parts and sub-assemblies of the machine which are subject to wear in normal usage conditions, regardless of the warranty period. Consumables include the following parts/sub-assemblies:

- collecting blades, blade fenders
- supporting wheels, slides,
- fuses.

The warranty service only applies to such cases as: mechanical damage which is not the user's fault, factory defects of parts, etc.

In the event of damage arising from:

- mechanical damage which is the user's fault, road accidents,
- inappropriate use, adjustment or maintenance, use of the machine for purposes other than those for which it is intended,
- use of damaged machine,

- repairs carried out by unauthorised persons, repairs carried out improperly,
- making unauthorised alterations to machine design,

the user will lose the right to warranty service.



Demand that the seller carefully and precisely fills out the *Warranty Book* and guarantee repair coupons. A missing date of purchase or sale point stamp may make the user ineligible for any warranty repair or refund.

The user is obliged to report immediately on noticing any wear in the paint coating or traces of corrosion, and to have the faults rectified whether they are covered by the warranty or not. Detailed guarantee regulations are contained in the *Warranty Book* attached to each machine.

Modifications of the machine without the written consent of the Manufacturer are prohibited. In particular, do NOT weld, drill holes in, cut or heat the main structural elements of the machine, which have a direct impact on the machine operation safety.

1.5 TRANSPORT

The machine is prepared for sale completely assembled and does not require packing. Packing is only required for the machine's technical documentation and any extra fittings.

Delivery is either by transport on a vehicle or independently. Transport of the machine connected to carrying vehicle is permissible provided that the driver familiarises himself with the Operator's Manual



When rising the machine by the transport lugs, the wings should be folded to the rear (Figure 1.2)

and particularly with safety information and principles of connection and transport on public roads. Do NOT drive the carrying vehicle with machine connected when visibility is limited.

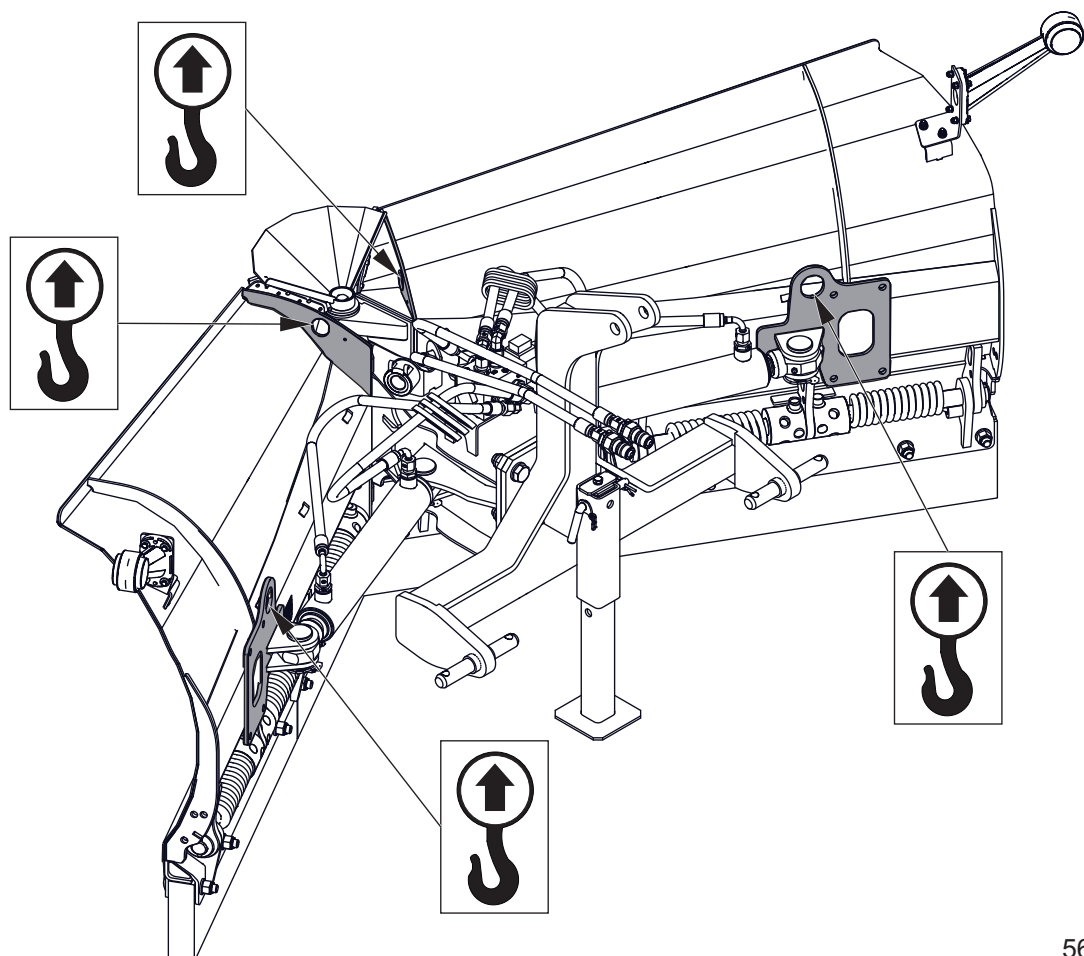

569-E.02-1

Figure 1.2 Transport lugs

During road transport the machine should be firmly secured on the load platform by means of certified belts or chains fitted with a tightening mechanism. During transport, the snow plough should be set in "arrow" position.

When loading and unloading the machine, comply with the general principles of workplace health and safety for reloading work. Persons operating reloading equipment

must have the qualifications required to operate these machines.



ATTENTION

Do NOT secure lifting slings or any types of securing elements to hydraulic cylinders. Nobody may be in the manoeuvring zone during transferring the machine to other form of transport.

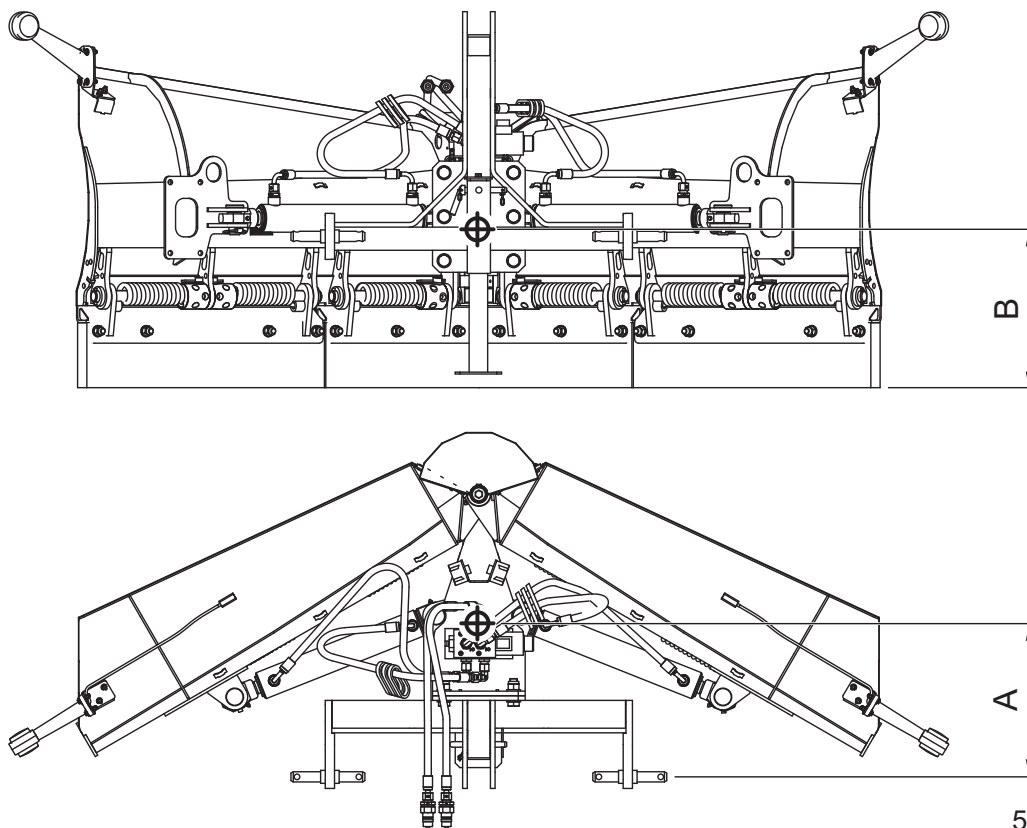

569-E.03-1

Figure 1.3 Centre of gravity
The machine without additional equipment. three-point linkage cat. 0/I (rigid)

Table 1.2 Centre of gravity.

Dimension	Unit	PUV-1800M	PUV-2000M
A	mm	330	320
B	mm	330	325

The machine should be attached to lifting equipment in places specially designed for this purpose (Figure 1.2), i.e. by the lugs on the right wing and the left wing. Suspension points are identified with information decals. When lifting the machine take particular care due to the possibility of tipping over the machine and the risk of injuries from protruding parts. During the loading work particular care should be taken not to damage paint coating.

**ATTENTION**

Depending on the machine equipment, location of centre of gravity varies in the range of ± 100 mm.

**ATTENTION**

When transporting independently, the user must carefully read this Operator's Manual and observe all recommendations. When being transported on a motor vehicle the machine must be mounted on the vehicle's platform in accordance with the transport safety requirements. The driver of the vehicle should take particular care while transporting the machine. This is due to the vehicle's centre of gravity shifting upwards when loaded with the machine.

E.2.2.569.05.1.EN

1.6 ENVIRONMENTAL HAZARDS

A hydraulic oil leak constitutes a direct threat to the natural environment owing to its limited biodegradability. While carrying out maintenance and repair work, which involves the risk of an oil leak, this work should take place on an oil resistant floor or surface. In the event of oil leaking into the environment, first of all contain the source of the leak, and then collect the leaked oil using available means. Remaining oil should be collected using sorbents, or by mixing the oil with sand, sawdust or other

absorbent materials. The oil contaminations, once gathered up, should be kept in a sealed, marked, hydrocarbon resistant container, and then passed on to the appropriate oil waste recycling centre. The container should be kept away from heat sources, flammable materials and food.

Oil which has been used up or is unsuitable for further use owing to loss of its properties should be stored in its original packaging in the conditions described above.

E.2.2.569.06.1.EN

1.7 WITHDRAWAL FROM USE

In the event of decision by the user to withdraw the machine from use, comply with the regulations in force in the given country concerning withdrawal from use and recycling of machines withdrawn from use.

Before proceeding to dismantle machine, oil shall be completely removed from hydraulic system.

When spare parts are changed, worn out or damaged parts should be taken to a collection point for recyclable raw materials. Used oil and also rubber and plastic elements should be taken to the appropriate facilities dealing with the recycling of this type of waste.



DANGER

During dismantling, use the appropriate tools, equipment (overhead travelling crane, crane or hoist etc.) and use personal protection equipment, i.e. protective clothing, footwear, gloves and eye protection etc.



DANGER

Disassembly of the hydraulic system should be performed by suitably qualified personnel. Before disassembly relieve the accumulator pressure on both the liquid and gas sides.

E.2.2.569.07.2.EN

SECTION 2

SAFETY ADVICE

2.1 PRINCIPLES OF SAFETY WHEN USING THE MACHINE

- Before using the machine, the user must carefully read this Operator's Manual and the *Warranty Book*. When operating the machine, the operator must comply with the recommendations.
- The machine may only be used and operated by persons qualified to drive carrying vehicles and trained in the use of the machine. Machine can be operated by a single person only.
- If the information in this Operator's Manual is difficult to understand, contact the dealer, who runs an manufacturer authorised service, or contact the manufacturer directly.
- Careless and incorrect use and operation of the machine, and non-compliance with the recommendations given in this Operator's Manual is dangerous to your health.
- Be aware of the residual risk. Use caution when operating this machine and follow all relevant safety instructions.
- The machine must never be used by persons who are not authorised to drive carrying vehicle, including children, and people under the influence of alcohol or other drugs.
- Non-compliance with the safety rules of this Operator's Manual can be dangerous to the health and life of the operator and others.
- The machine must not be used for purposes other than those for which it is intended. Anyone who uses the machine in any other way than the way intended takes full responsibility for any consequences of this use. Use of the machine for purposes other than those for which it is intended by the Manufacturer may invalidate the guarantee.
- The machine may only be used when all the protective elements (i.e. safety guards, bolts, cotter pins) are technically sound and correctly positioned. In the event of loss or destruction of the protective elements, they must be replaced with new ones.

F.2.2.569.01.1.EN

2.2 SAFETY WHEN HITCHING THE MACHINE

- Do NOT hitch the machine to a carrying vehicle, if the linkage system of the machine is not compatible with the linkage system of the carrying vehicle.
- To hitch the machine to the carrying vehicle use only linking elements recommended by the Manufacturer.
- The carrying vehicle to which the machine will be coupled must be technically reliable and must fulfil the requirements specified by the machine Manufacturer.
- Be especially careful when hitching and unhitching the machine.
- When hitching, there must be nobody between the machine and the carrying vehicle.
- After hitching the machine, check the safeguards. Carefully read the carrying vehicle Operator's Manual.
- The machine disconnected from the carrying vehicle must be supported on the snow plough blade and slides or wheels (depending on the machine's equipment) and placed on level, sufficiently hard surface in such a manner as to ensure that it is possible to connect it again. The wings should be folded to the rear.

F.2.2.569.02.1.EN

2.3 SAFETY RULES WHEN MAINTAINING THE HYDRAULIC SYSTEM

- The hydraulic system is under high pressure when operating.
- Regularly check the technical condition of the connections and the hydraulic conduits. There must be no oil leaks.
- In the event of the hydraulic system malfunction, discontinue using the machine until the malfunction is corrected.
- When connecting the hydraulic conduits to the carrying vehicle, make sure that the hydraulic system of the machine is not under pressure. If necessary, reduce residual pressure in the system.
- In the event of injuries being caused by pressurised hydraulic oil, contact a doctor immediately. Hydraulic oil may find its way under the skin and cause infections. In the event of contact of oil with eyes, rinse eyes with a large quantity of water and in the event of the occurrence of irritation consult a doctor. In the event of contact of oil with skin wash the area of contact with water and soap. Do NOT apply organic solvents (petrol, kerosene).
- Use the hydraulic oil recommended by the Manufacturer. Never mix two types of oil.
- After changing the hydraulic oil, the used oil should be properly disposed of. Used oil or oil which has lost its properties should be stored in original containers or replacement containers resistant to action of hydrocarbons. Replacement containers must be clearly marked and appropriately stored.
- Do not store hydraulic oil in packaging designed for storing food or foodstuffs.
- Rubber hydraulic conduits must be replaced every 4 years regardless of their technical condition.
- Repair and replacement of hydraulic system elements should be entrusted to the appropriately qualified persons.

F.2.2.569.03.1.EN

2.4 SAFETY DURING TRANSPORT TRAVEL

- When driving on public roads, comply with the road traffic regulations in force in the country, in which the machine is used.
- Do not exceed the permitted speed arising from road conditions and design limitations. Adjust travelling speed to the prevailing road conditions and other limitations specified in the road traffic regulations.
- When driving with raised machine, the carrying vehicle's linkage should be locked in the up position to prevent its accidental lowering (if it is possible).
- Do NOT leave the machine raised and unsecured while the carrying vehicle is parked. When parked, the machine should be lowered.
- Do NOT ride on the machine or transport any materials on it.
- Before using the machine always check its technical condition, especially in terms of safety. In particular, check the technical condition of the linkage and components of the hydraulic system and electrical system.
- Reckless driving and excessive speed may cause accidents.

F.2.2.569.04.1.EN

2.5 MAINTENANCE

- During the warranty period, any repairs may only be carried out by warranty service authorised by the Manufacturer. It is recommended that necessary repairs to machine should be undertaken by specialised workshops.
- In the event of any fault or damage, do not use the machine until the fault has been corrected.
- During work, use the proper, close-fitting protective clothing, gloves and appropriate tools. When working on hydraulic systems it is recommended to use oil resistant gloves and protective goggles.
- Any modification to the machine frees PRONAR from any responsibility for damage or detriment to health which may arise as a result.
- Regularly check the technical condition of the safety devices and correct tightening of bolt connections.
- Regularly perform service inspections of machine as recommended by the Manufacturer.
- Do NOT perform maintenance or repair work under raised and unsupported machine.
- Before beginning repair works on hydraulic systems, reduce oil pressure.
- Servicing and repair work should be carried out in line with the general principles of workplace health and safety. In the event of injury, the wound must be immediately cleaned and disinfected. In the event of more serious injuries, seek a doctor's advice.
- Repair, maintenance and cleaning work should be carried out with the carrying vehicle's engine turned off and the ignition key removed. Immobilise the carrying vehicle with parking brake and ensure that unauthorised persons do not have access to the vehicle's cab.
- Should it be necessary to change individual parts, use only original parts. Non-adherence to these requirements may put the user and other people's health and life at risk, and also damage the machine and invalidate the warranty.
- In the event of work requiring the machine to be raised, use properly certified hydraulic or mechanical lifts for this purpose. After lifting the machine, stable and durable supports must also be used. Do NOT carry

out work under a machine, which has been raised only with the three point linkage.

- The machine must not be supported using fragile elements (bricks or concrete blocks).
- Do NOT weld, drill holes in, cut or heat the main structural elements,

which have a direct impact on the machine operation safety.

- After completing work associated with lubrication, remove excess oil or grease.
- In order to reduce the danger of fire the machine must be kept in a clean condition.

F.2.2.569.05.1.EN

2.6 SAFETY DURING SNOW PLOUGH OPERATION

- Before lowering or lifting the machine mounted on carrying vehicle make sure there are no bystanders, especially children, near the machine.
- Before starting the machine make sure that there are no bystanders (especially children) or animals in the danger zone. The carrying vehicle operator is obliged to ensure proper visibility of the machine and the working area.
- During machine operation do not occupy a different position than that of the operator in the vehicle's cab. Do NOT leave the cab, when the machine is in operation.
- Person must not stand in the machine operation area and also between the carrying vehicle and the machine.
- Do NOT operate the snow plough while reversing. While reversing, raise the machine.
- Do NOT use the snow plough with additional ballast.

F.2.2.569.06.1.EN

2.7 RESIDUAL RISK

Pronar Sp. z o. o. in Narew has made every effort to eliminate the risk of accidents. There is, however, a certain residual risk, which could lead to an accident, and this is connected mainly with the actions described below:

- using the machine for purposes other than those for which it is intended,
- being between the carrying vehicle and the machine while the engine is running and when the machine is being hitched,
- being on the machine while the engine is running,
- not maintaining a safe distance from the danger zone or being within the zones while the machine is operating,
- operation of the machine by unauthorised persons or persons under the influence of alcohol or other intoxicating substances,
- cleaning, maintenance and technical checks when carrying vehicle is

connected and engine is running.

The residual risk may be kept to a minimum by following the recommendations below:

- operate the machine in prudent and unhurried manner,
- sensibly apply the remarks and recommendations contained in the Operator's Manual,
- carry out repair and maintenance work in line with operating safety rules,
- repair and maintenance work should be carried out by persons trained to do so,
- use close fitting protective clothing,
- ensure unauthorised persons have no access to the machine, especially children,
- maintain a safe distance from prohibited or dangerous places
- do not climb on the machine when it is operating

F.2.2.569.07.1.EN

2.8 INFORMATION AND WARNING DECALS





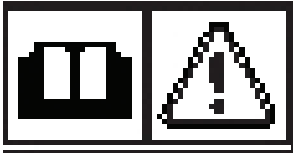
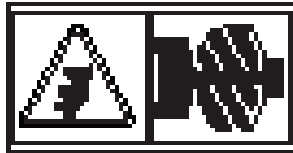
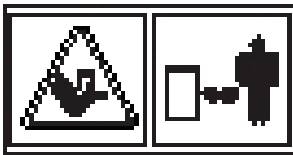
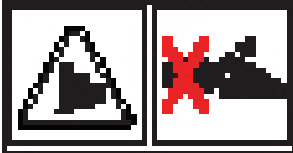
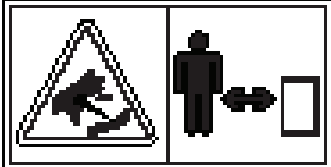

All signs should always be legible and clean, visible to the operator and also to persons possibly being in the vicinity of the machine in operation. If any safety sign is lost or illegible, it should be replaced with a new one. All elements having safety signs replaced during repairs should be

affixed with these signs. Safety signs and decals may be purchased from the Manufacturer or the Seller.

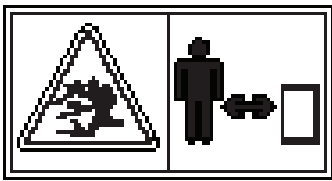
During machine cleaning do not use solvents which may damage the coating of information label stickers and do not subject them to strong water jets.

Table 2.1 Information and warning decals

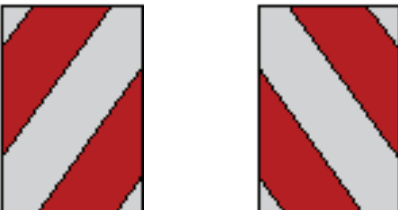
Item	Decal	Meaning
1		Before starting work, carefully read the Operator's Manual.
2		When implement is in use there must be no bystanders in designated areas. If any work is required in these areas, make sure the carrying vehicle is stationary, and whether the implement is disconnected from the power source.
3		Risk of injury to foot or leg. Keep a safe distance.
4		Do not reach into crushing space because elements may move. Danger of crushing hands or fingers.
5		Pressurised liquid. Keep a safe distance from the operating machine.

Item	Decal	Meaning
6		<p>Danger caused by materials thrown out by the machine. Keep a safe distance from the operating machine.</p>
7		<p>Machine model.</p>
8		<p>Lifting equipment attachment points for loading the machine.</p>
9		<p>PRONAR decal.</p>
10		<p>Outline marking.</p>
11		<p>Danger. Hydraulic accumulator. Pressurised nitrogen: 65 bar. Release pressure from the system before the technical inspection Label of hydraulic accumulator.</p>

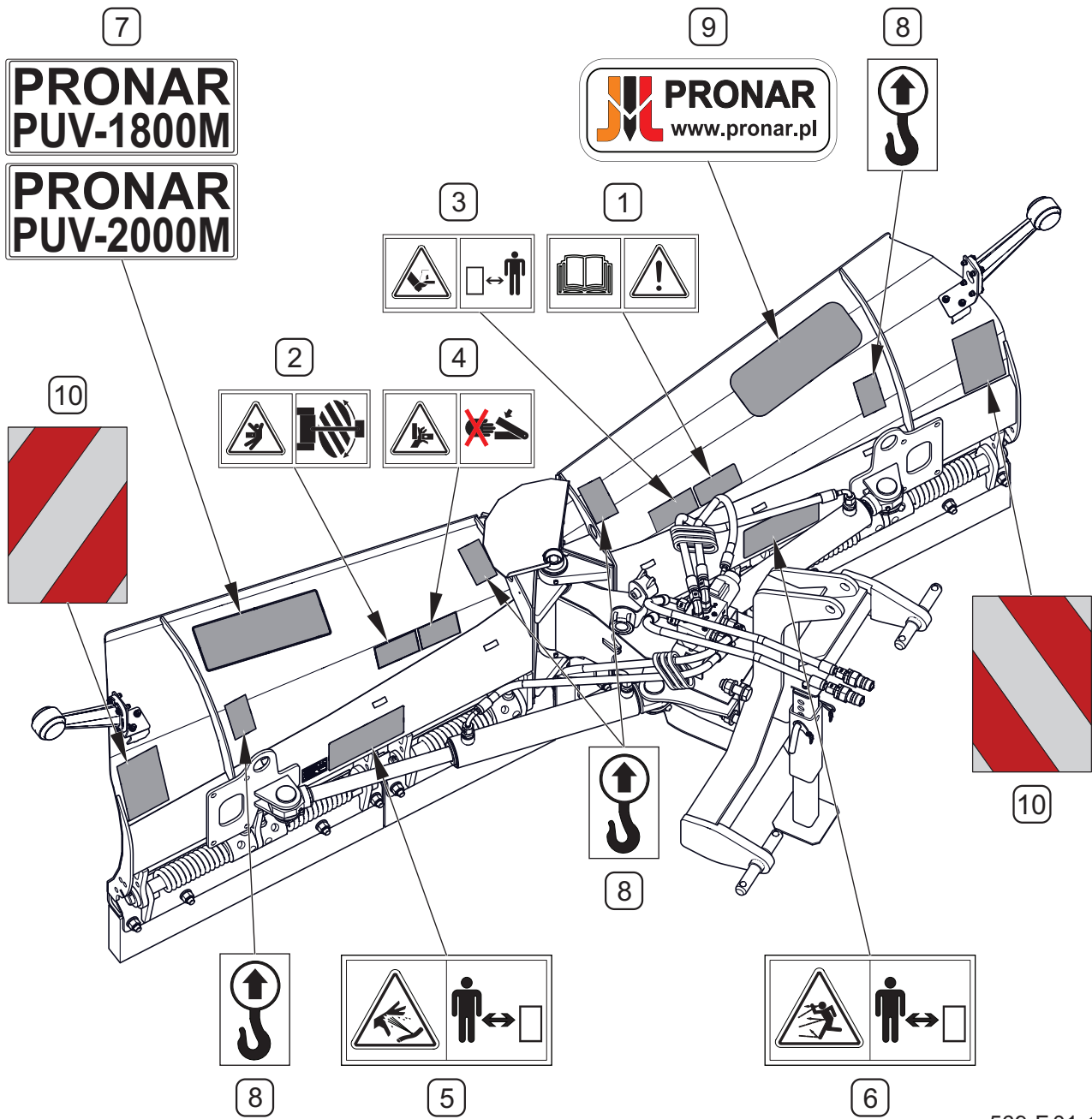

569-F.01-1

Figure 2.1 Locations of information and warning decals.

F.2.2.569.08.1.EN

SECTION 3

DESIGN AND OPERATION

3.1 TECHNICAL SPECIFICATION

Table 3.1 Basic technical specification

	Unit	PUV-1800M	PUV-2000M
Method of hitching to carrying vehicle - three point linkage	-	Category 0/I according to ISO 730-1	
Working width (Figure 3.1)*: - L, P - snow clearing to the left/ to the right - S - symmetrically to the left/right - SO - collecting inside	mm	1 580 1 560 1 600	1 750 1 730 1 775
Mouldboard height* <i>maximum</i>	mm	660	670
Total height**: - rigid linkage - swinging linkage	mm	812 735	
Minimum length (<i>position S</i>)**: - rigid linkage - swinging linkage	mm	770 790	
Width (<i>without fenders</i>)*	mm	1 800	2 000
Supply	-	external hydraulic system and 12V electrical system of the carrying vehicle	
Control	-	hydraulic using solenoid	
Types of collecting blades (<i>depending on equipment version</i>)	-	rubber snow plough blades (set at the angle of 90° to the ground) steel snow plough blades (set at the angle of 60° to the ground) steel snow plough blades (set at the angle of 90° to the ground) perforated steel snow plough blades (set at the angle of 60° to the ground)	
Weight** - 0/I rigid linkage - 0/I swinging linkage	kg kg	176 197	187 208
Working speed <i>maximum</i>	km/h	10	
Power demand	hp	30 ÷ 50	
Other information	-	single person operation	

* - for the machine with rubber blades

** - for the machine in standard version (rubber blades without fenders, three-point linkage of category 0/1, without slides, without wheels, independent control without shock absorbers, clearance lights)

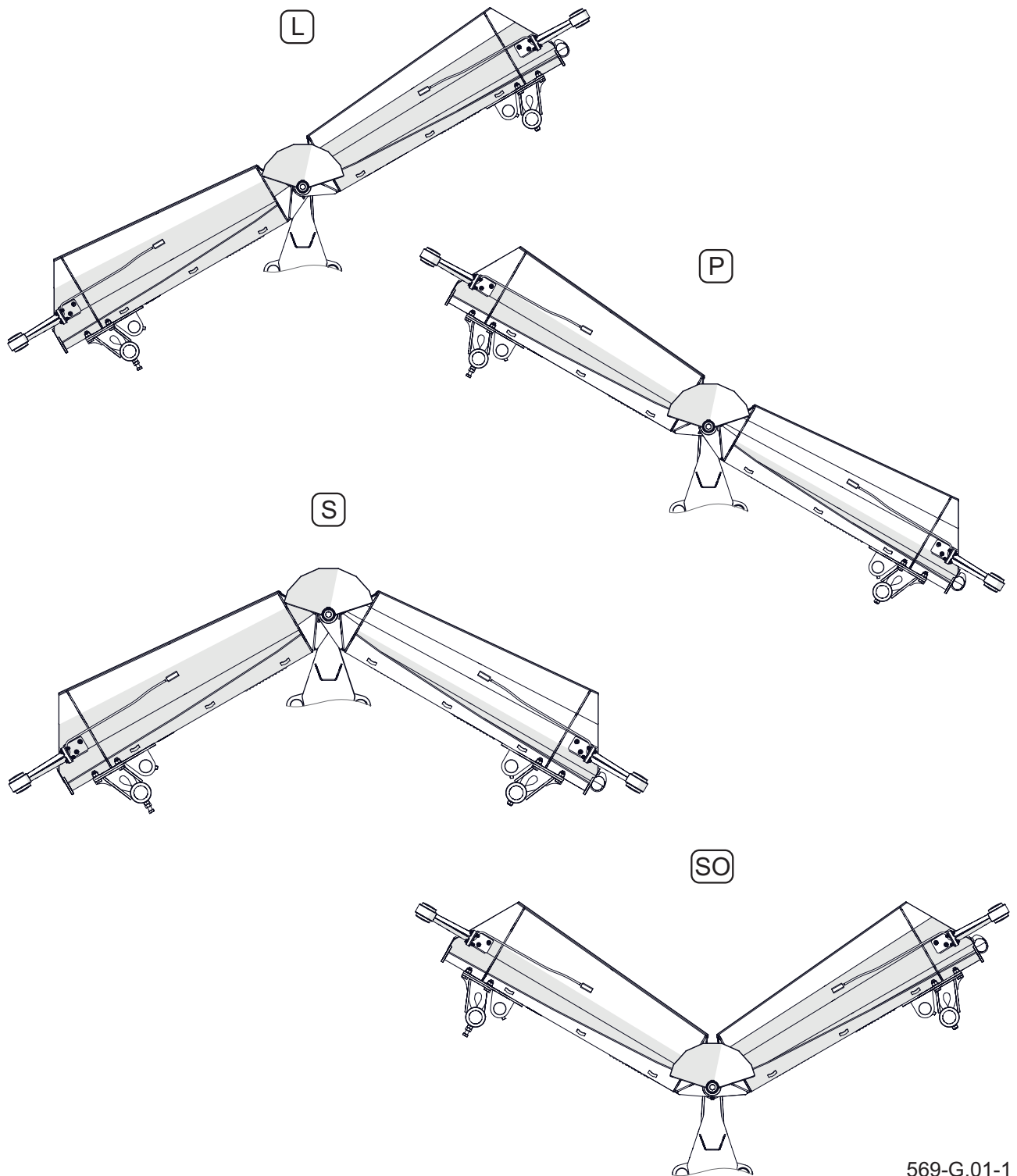

569-G.01-1

Figure 3.1 Working positions
 (L) snow clearing to the left, (P) snow clearing to the right, (S) symmetrically to the left - right
 (SO) collecting inside

3.2 GENERAL DESIGN

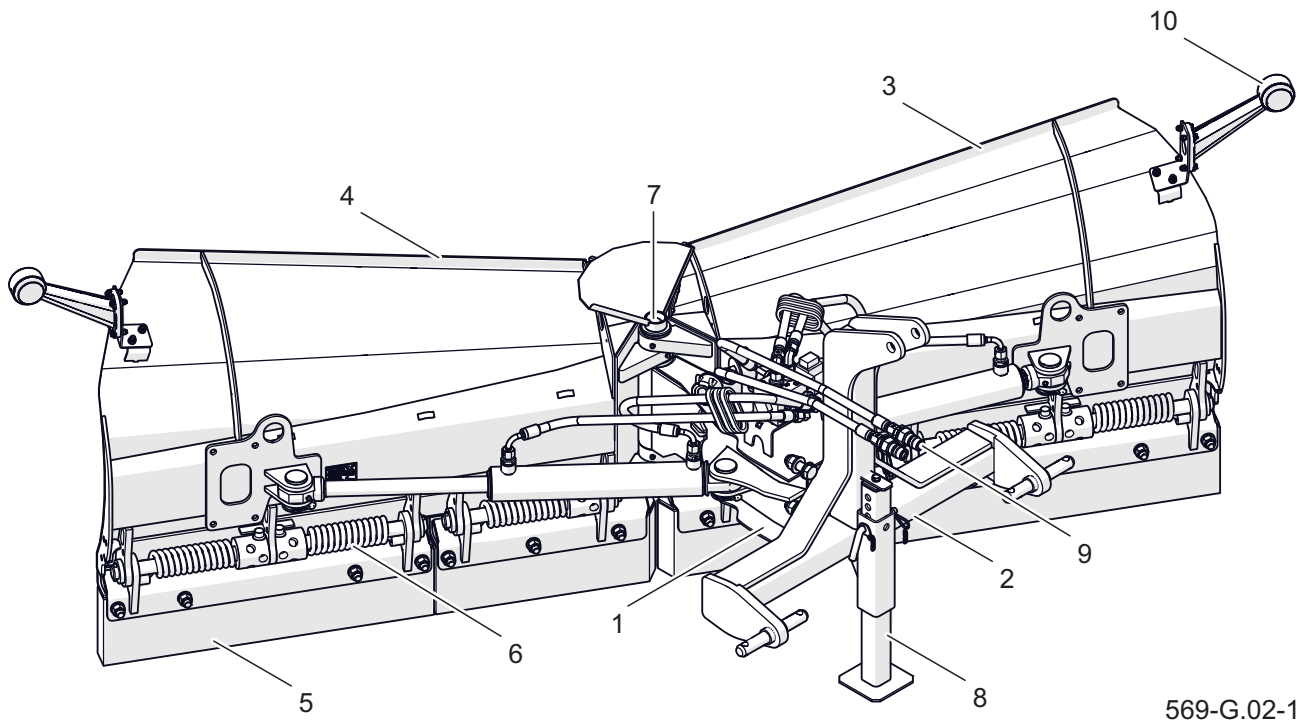

569-G.02-1

Figure 3.2 General design

- | | | |
|------------------------|-------------------|----------------------|
| (1) frame | (2) linkage | (3) right wing |
| (4) left wing | (5) rubber blade | (6) spring |
| (7) main pin | (8) parking stand | (9) hydraulic system |
| (10) electrical system | | |

PUV-1800M/PUV-2000M snow plough (Figure 3.2) consists of frame (1) to which right (3) and left (4) wings are connected by means of main pin (7). The snow plough is hitched to a carrying vehicle using a suitable linkage system (2). Rubber or metal blades (5) with shock absorbing springs are able to swing backwards when

an obstacle is encountered. The snow plough's mouldboards are controlled by means of hydraulic system (9). Depending on its version, the snow plough can be equipped with supporting wheels, slides and other linkage systems for hitching the snow plough to a wide range of carrying vehicles.

G.2.2.569.02.1.EN

3.3 HYDRAULIC SYSTEM

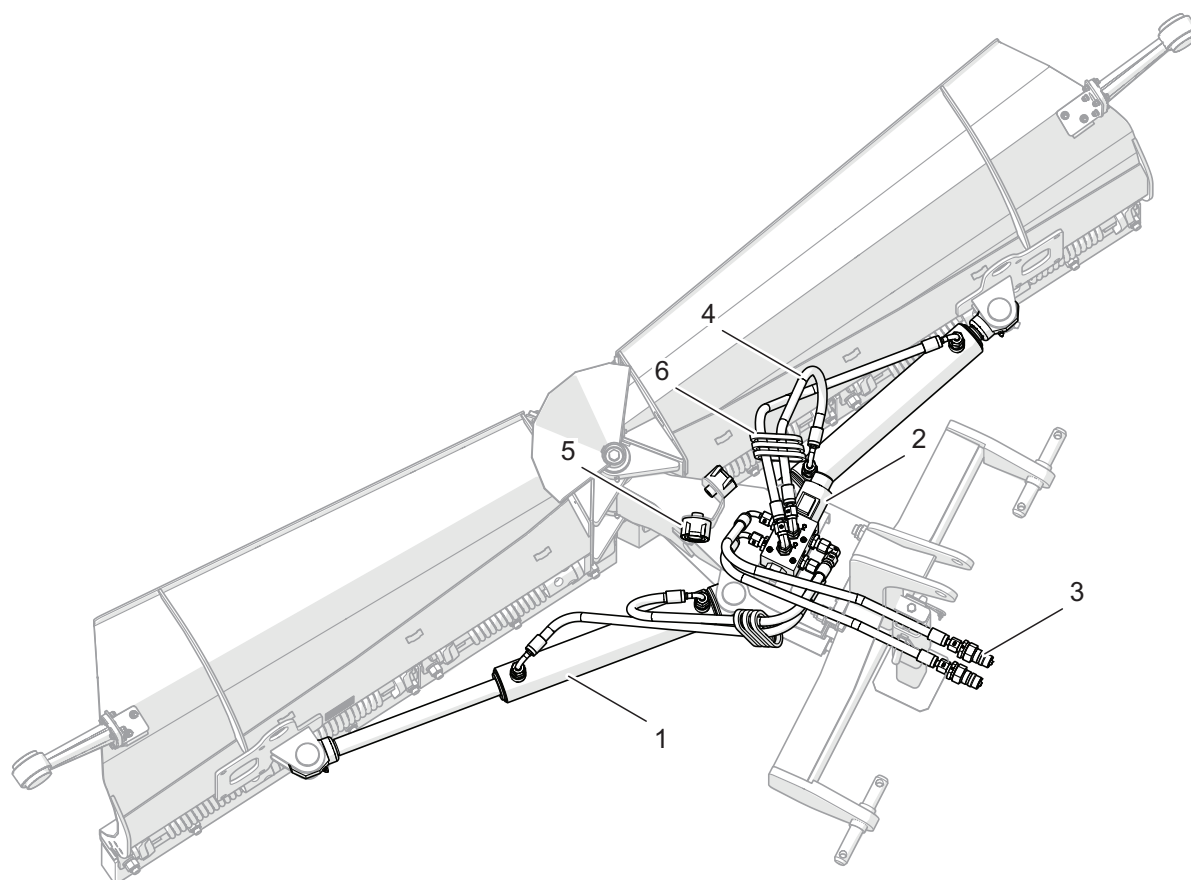

569-G.03-1

Figure 3.3 Hydraulic system design (standard version)

(1) actuator
(4) conduit

(2) hydraulic solenoid valve
(5) protection of quick couplers

(3) quick coupler
(6) protective sleeve

Working position of the snow plough mouldboards can be adjusted by means of two hydraulic cylinders (1) controlled by solenoid valve (2). The snow plough's hydraulic system is supplied with oil from the carrying vehicle's hydraulic system

via two conduits (4) terminated with quick couplers (3).

The snow ploughs with hydraulic shock absorbers (Figure 3.5 and 3.6) are also equipped with hydraulic accumulator and solenoid valve with overpressure valve.

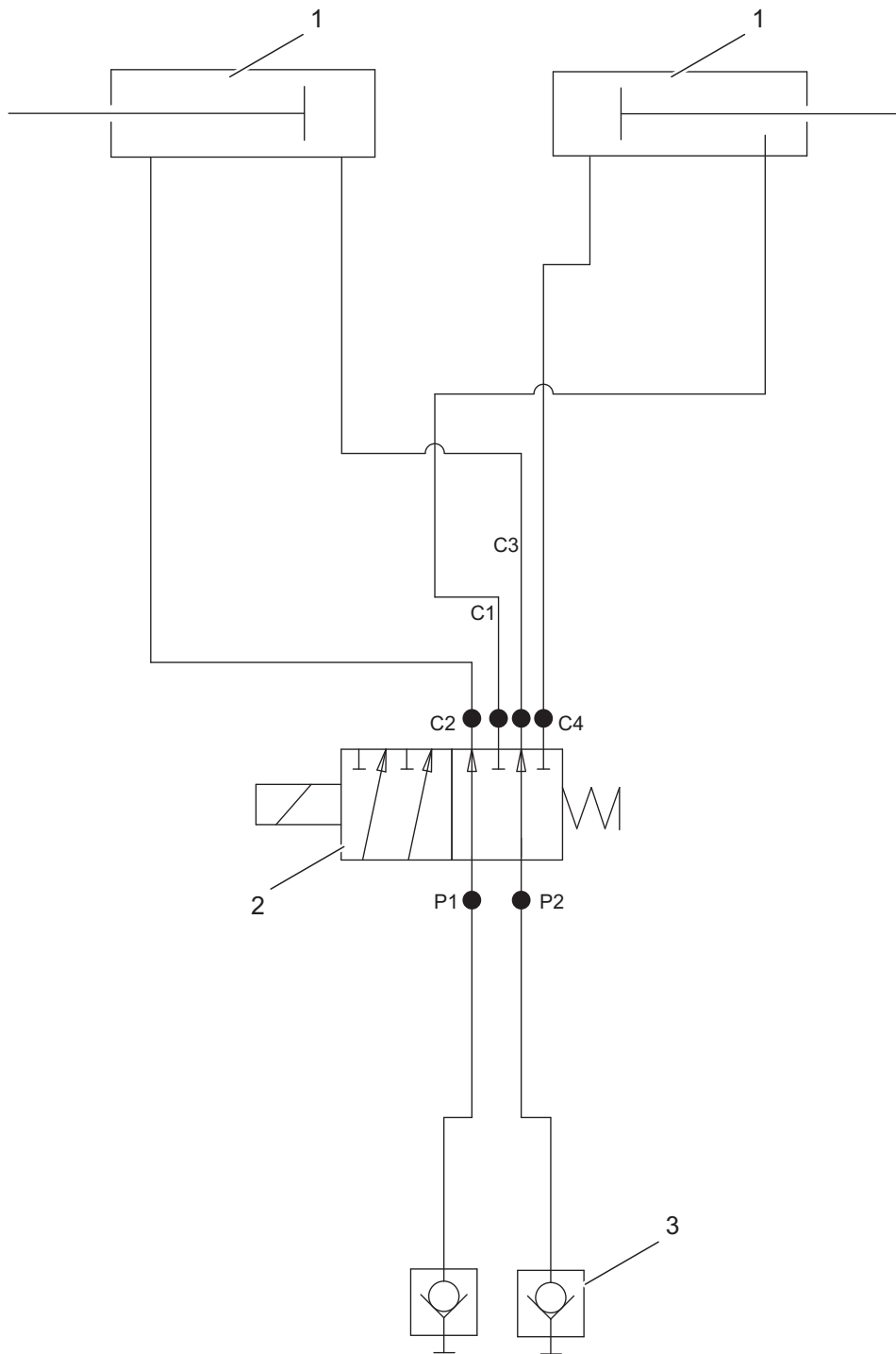

569-G.04-1

Figure 3.4 Diagram of the hydraulic system (standard version)
 (1) actuator (2) hydraulic solenoid valve (3) quick coupler

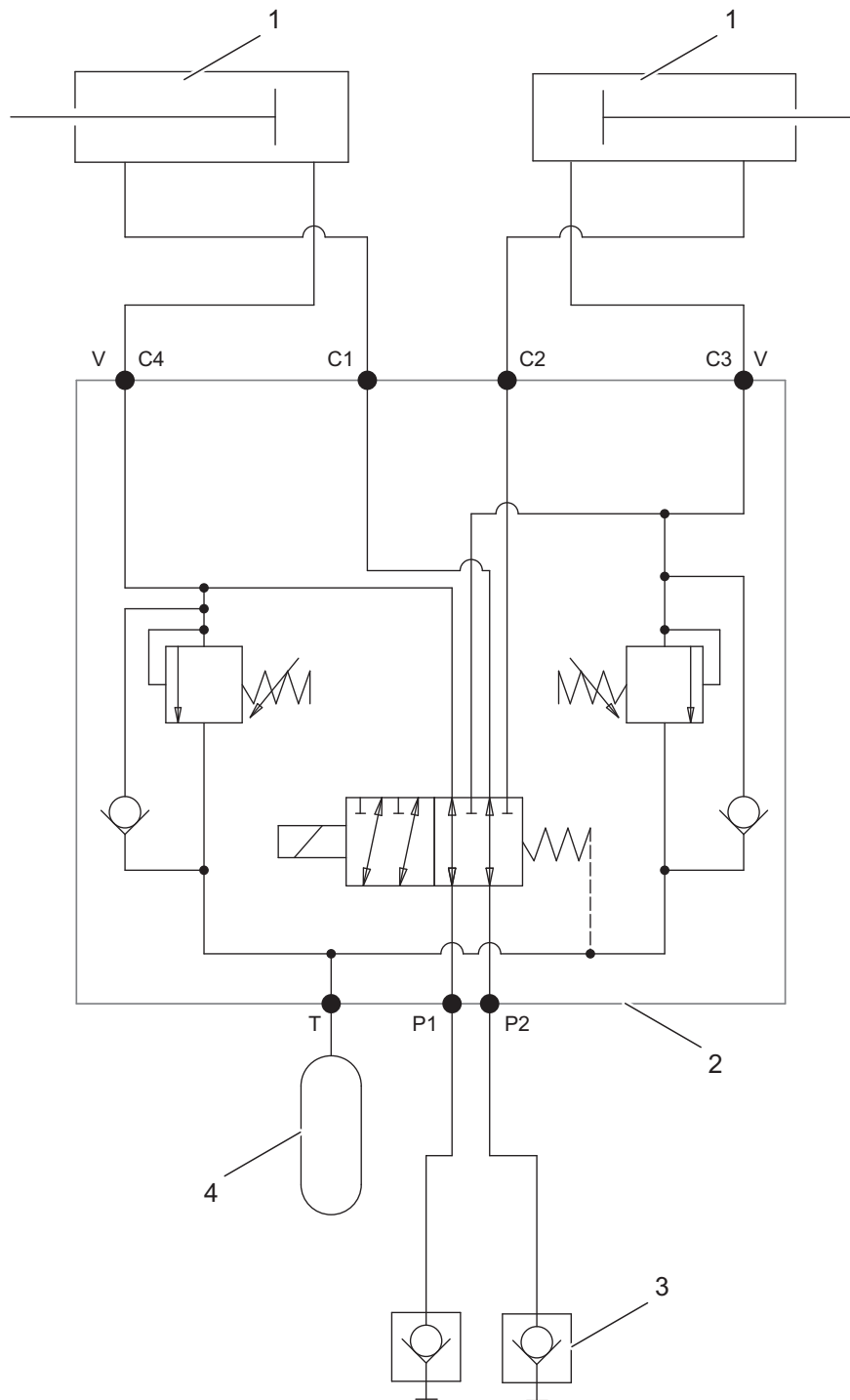

569-G.05-1

Figure 3.5 Diagram of the hydraulic system (with hydraulic shock absorbers)
 (1) actuator (2) hydraulic solenoid valve with overpressure valve
 (3) quick coupler (4) hydraulic accumulator



ATTENTION
 The system contains a hydraulic accumulator.

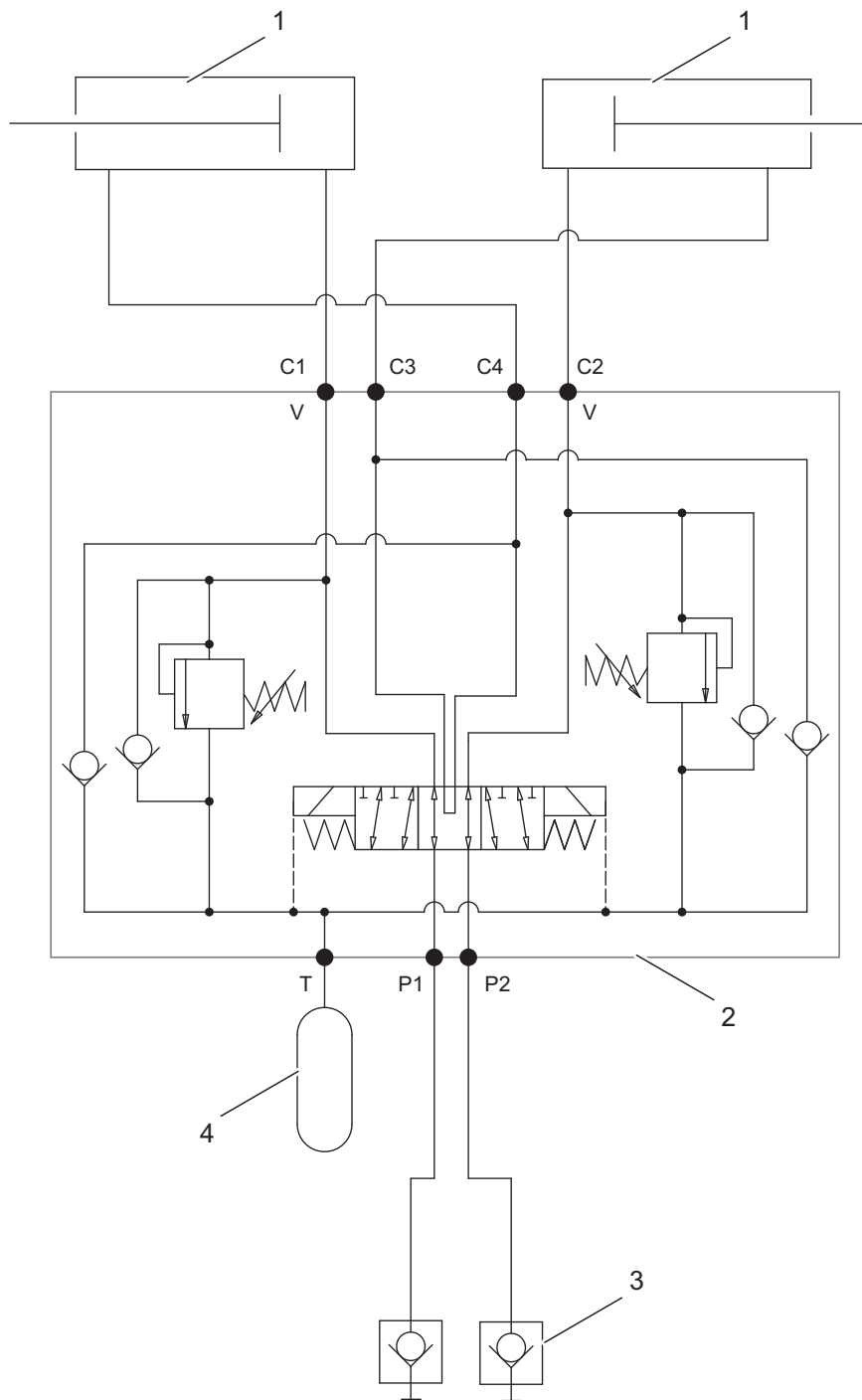

569-G.06-1

Figure 3.6 Diagram of the hydraulic system (with hydraulic shock absorbers), independent-simultaneous control)

- (1) actuator
- (2) hydraulic solenoid valve with overpressure valve
- (3) quick coupler
- (4) hydraulic accumulator



ATTENTION

The system contains a hydraulic accumulator.

3.4 ELECTRICAL SYSTEM

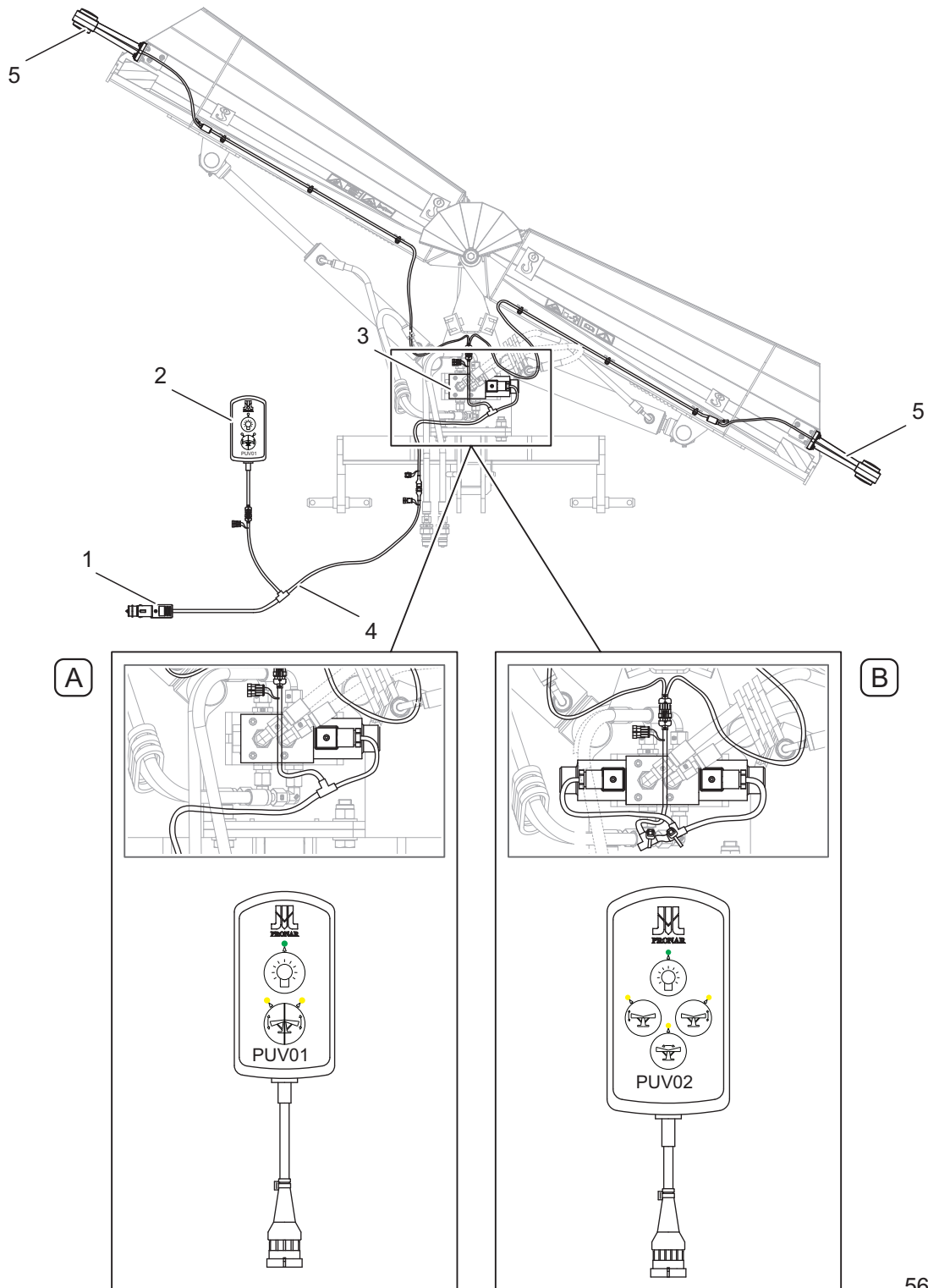

569-G.07-1

Figure 3.7 Electrical system design

(A) independent control

(B) independent-simultaneous control

(1) cigarette lighter socket plug

(2) control panel

(3) solenoid valve

(4) connection lead

(5) clearance lamp

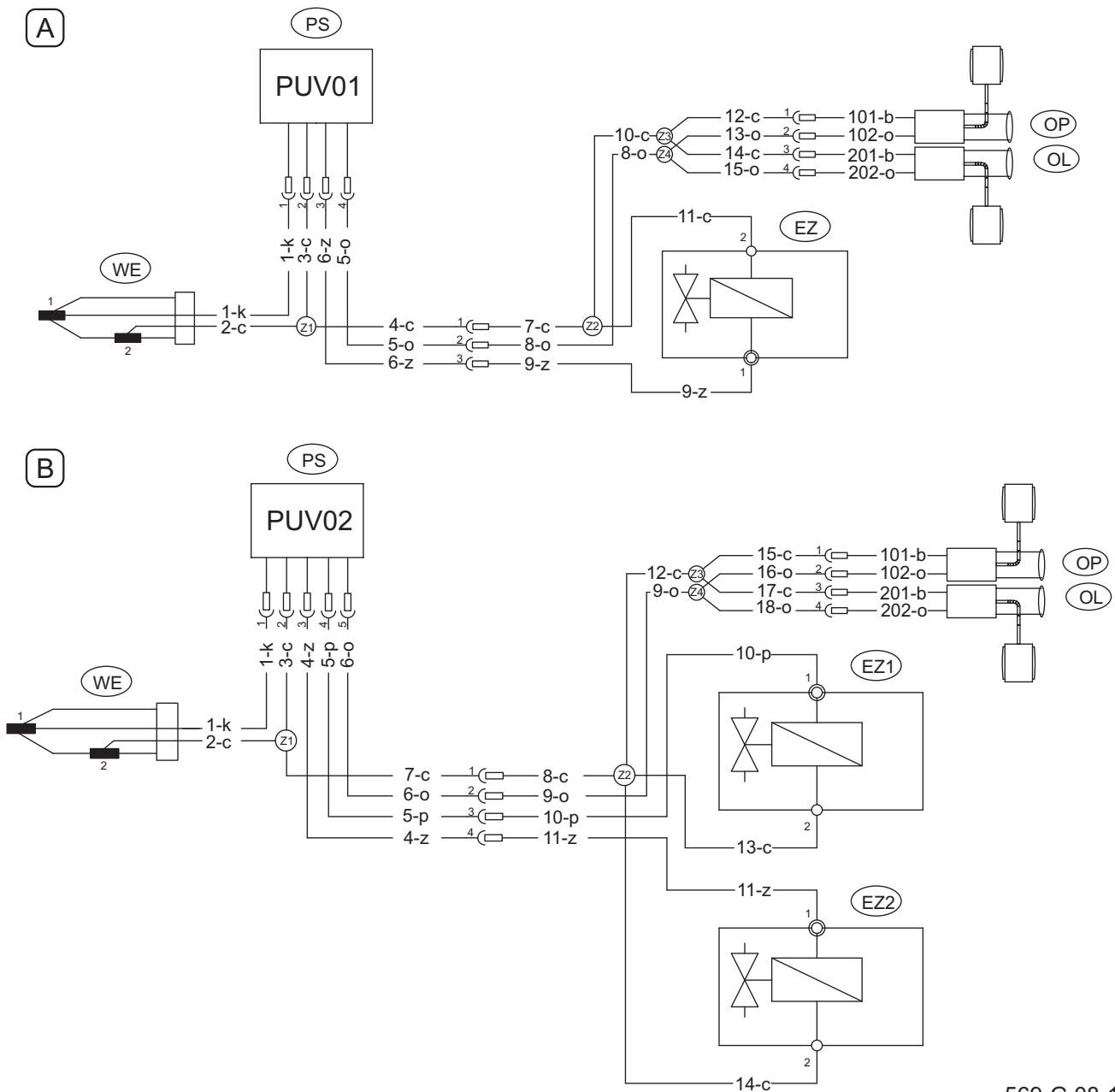

569-G.08-1

Figure 3.8 Electrical system diagram

(A) independent control

(B) independent-simultaneous control

(WE) cigarette lighter socket plug (OP) right clearance light

(OL) left clearance light

(EZ) solenoid valve

(EZ1) solenoid valve 1

(EZ2) solenoid valve 2

(PS) control panel

G.2.2.569.04.1.EN

SECTION 4

CORRECT USE

4.1 PREPARING FOR WORK

The manufacturer guarantees that the machine is fully operational and has been checked according to quality control procedures and is ready for use. This does not release the user from an obligation to check the machine's condition after delivery and before first use. The machine is delivered to the user completely assembled (unless otherwise agreed with the customer).



DANGER

Before using the snow plough, the user must carefully read this Operator's Manual.

Careless and incorrect use and operation of the machine, and non-compliance with the recommendations given in this Operator's Manual is dangerous to your health.

The machine must never be used by persons, who are not authorised to drive carrying vehicles, including children and people under the influence of alcohol or other drugs.

Non-compliance with the safety rules of this Operator's Manual can be dangerous to the health and life of the operator and others.

Before starting the machine, make sure that there are no bystanders in the danger zone.

Before hitching to carrying vehicle, the operator must check the technical condition of the machine and prepare it for test start-up. In order to do this:

- the user must carefully read this Operator's Manual and observe all recommendations, understand the

design and the principle of machine operation,

- check the compatibility of the machine's linkage with the carrying vehicle's linkage,
- make sure that electrical system parameters as well as connection sockets are compatible,
- make sure that hydraulic system parameters as well as connection sockets are compatible,
- check the condition of protective paint coat,
- inspect machine's individual components for mechanical damage resulting from incorrect transport (dents, piercing, bent or broken components),



ATTENTION

Before beginning work lubricate all lubrication points.

- check all lubrication points, lubricate the machine according to recommendations provided in section 5 "*Maintenance*",
- check technical condition of the hydraulic and electrical system;
- check technical condition of wings,

collecting blades, slides or supporting wheels,

- check technical condition of the linkage components,

If all the above checks have been performed and there is no doubt as to the machine's good technical condition, hitch the machine to the carrying vehicle, start the carrying vehicle, check individual systems and perform a test run before beginning work. In order to inspect:

- hitch the machine to carrying vehicle (see "*Hitching to carrying vehicle*"),
- after connecting the electrical and hydraulic system wiring, check the

correct operation of individual machine functions and operation of lighting system and inspect tightness of the system and hydraulic cylinders.

In the event of a disruption in the operation of the machine immediately discontinue its use, find and remove the fault. If a fault cannot be rectified or the repair could void the warranty, please contact the Manufacturer for additional clarifications.

**ATTENTION**

Before using the machine always check its technical condition. In particular check the technical condition of the hitch and hydraulic system.

H.2.2.569.01.1.EN

4.2 TECHNICAL INSPECTION

When preparing the machine for use, check individual elements according to guidelines presented in Table 4.1.



ATTENTION

The machine must not be used when not in working order.

Table 4.1 Technical inspection schedule

Description	Maintenance activities	Frequency
Technical condition of mould-board and collecting blades	Visually inspect and, if necessary, replace according to section " <i>Checking and replacement of collecting blades</i> "	Before commencing work
Technical condition of slides or supporting wheels (depending on machine equipment)	Check technical condition, if complete and correctly mounted.	
Technical condition of the linkage, locking bolts and pins.	Check technical condition, if complete and correctly mounted.	
Technical condition of the hydraulic system.	Visually inspect the technical condition	
Technical condition of the electrical system	Visually inspect the technical condition, check the operation	
Check if all main nut and bolt connections are properly tightened	Tightening torque values should be according to table " <i>Tightening torque for nut and bolt connections</i> "	Once a week
Lubrication	Lubricate components according to section " <i>Lubrication</i> "	According to table (5.8)

H.2.2.569.02.1.EN

4.3 HITCHING TO VEHICLE

The snow plough can be hitched to a carrying vehicle that meets the requirements contained in Table 1.1 *Requirements for carrying vehicle*.



ATTENTION

Before hitching the machine to carrying vehicle, the user must carefully read the operator's manual of the carrying vehicle.

Depending on machine version, the snow plough can be equipped with a wide range of linkage systems. Before mounting the machine on the carrying vehicle, check the linkage compatibility. The method of hitching the snow plough to the carrying vehicle may differ depending on the type of carrying vehicle.

HITCHING TO THE THREE POINT LINKAGE

Before hitching the snow plough to tractor three-point linkage, make sure that the category of the tractor linkage is compatible with that of the snow plough.



DANGER

When hitching, there must be nobody between the machine and the carrying vehicle. Exercise particular caution.

In order to hitch the snow plough to the tractor three-point linkage:

- move the lower links of tractor three-point linkage to the lower linking points of the snow plough; set lower links at an appropriate height,
- turn off tractor engine and prevent tractor from moving,
- connect the lower pins of the snow plough linkage with three-point linkage and secure with linchpins,



DANGER

To hitch the machine to the carrying vehicle use only linking elements recommended by the Manufacturer.

- in the case of the hook linkage, place balls on snow plough linkage pins,

secure with linchpins and lift the pins until balls lock in hooks,

- connect tractor upper link (central connector) to the snow plough upper attachment point and secure with cotter pin,
- eliminate lateral snow plough movements by appropriate adjustment of the lower arm stabilisers (if present); it is recommended that both the lower links of the three-point linkage are set at the same height,
- connect plugs of the electrical system and hydraulic system conduits,
- lift the snow plough using the tractor three point linkage.



ATTENTION

Before mounting the machine on the carrying vehicle, check the linkage compatibility. The connecting cables should be routed so that they do not get entangled in moving machine parts.

CONNECTING THE HYDRAULIC SYSTEM

The snow plough's hydraulic quick couplers (Figure 4.1) should be connected to two connections in one section of the carrying vehicle's external hydraulic circuit. Depending on its version, the machine can be equipped with two hydraulic conduit plugs (1) or a plug (1) and a hydraulic socket (2).

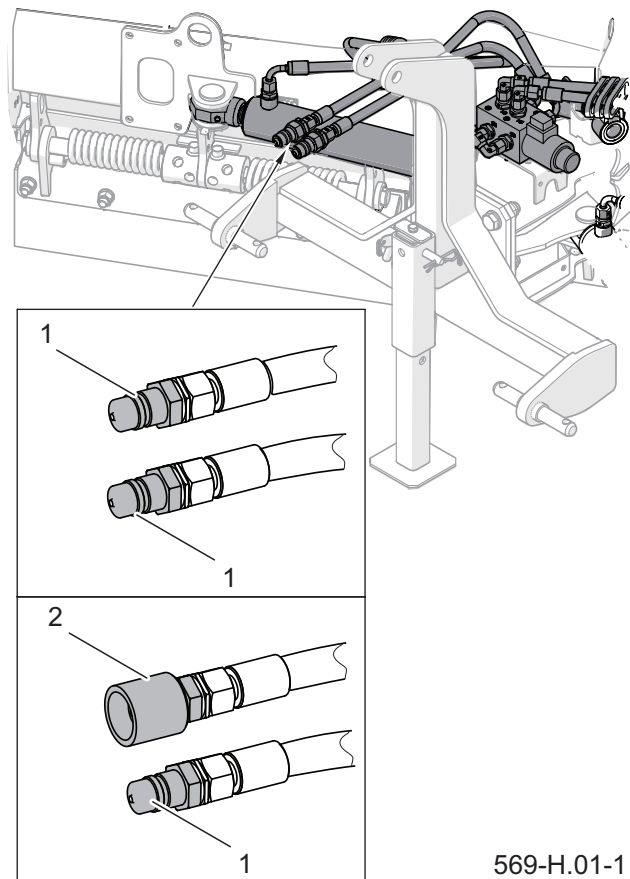

569-H.01-1

Figure 4.1 Hydraulic quick couplers
(1) quick coupler plug (2) quick coupler socket



DANGER

Reduce pressure in the carrying vehicle's hydraulic system prior to connecting the snow plough's hydraulic system.

CONNECTING THE ELECTRICAL SYSTEM

Connect plug (1) of connection lead (2) to 12V cigarette lighter socket in the carrying vehicle; connect control panel (3) to

lead (2) and place it in an accessible place in the operator's cab. Arrange electrical wires so as to prevent their damage during operation.

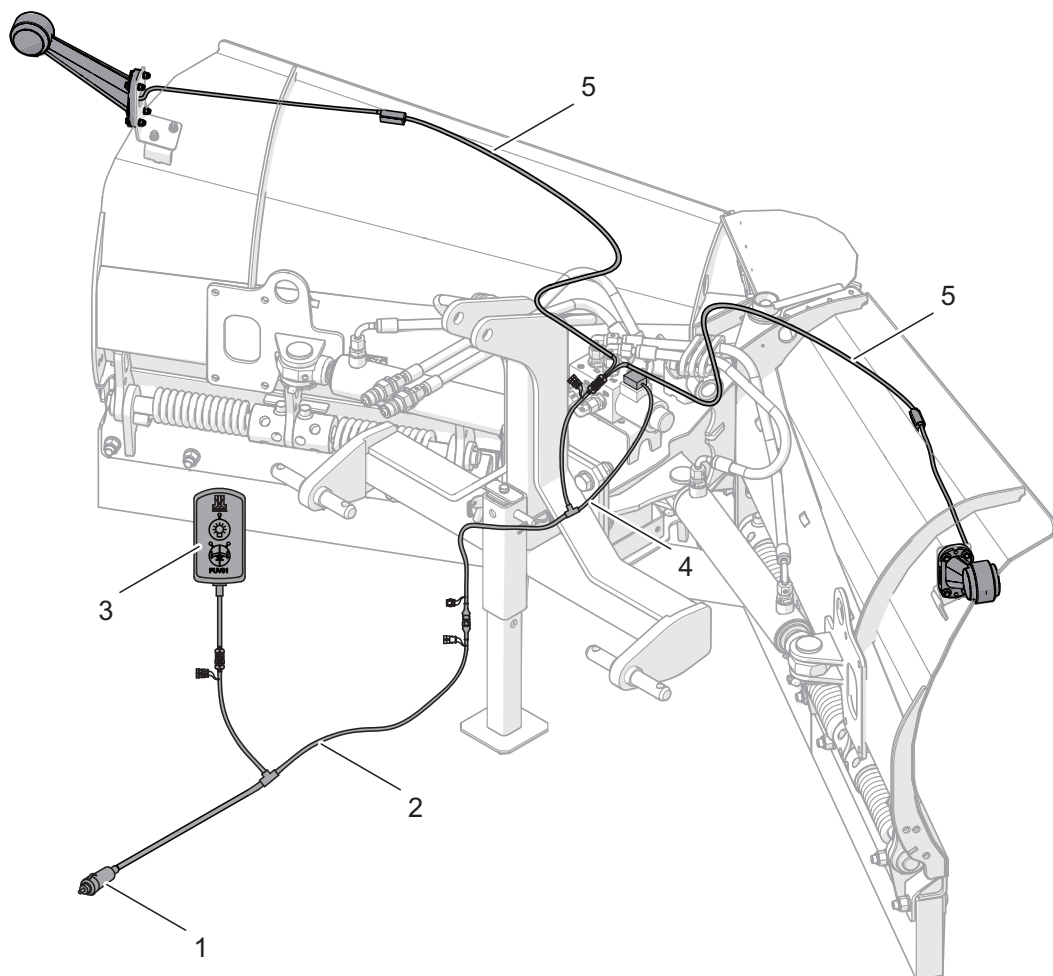

569-H.02-1

Figure 4.2 Connecting the electrical system

(1) cigarette lighter socket plug

(2) connection lead

(3) control panel

(4) solenoid valve control lead

(5) lighting system lead

H.2.2.569.03.1.EN

4.4 SNOW PLOUGH OPERATION

LEVELLING THE SNOW PLOUGH BODY

To ensure optimum operation, the snow plough body should be level (the main blades pivot axis (1) should be perpendicular to the ground). Levelling of the snow plough body in the carrying vehicles with three-point linkage is done by adjusting the central link (2) (Figure 4.3).

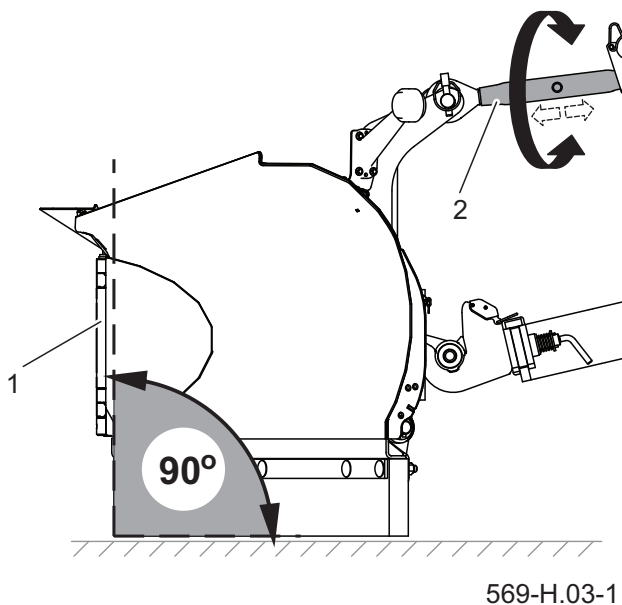

Figure 4.3 Levelling the snow plough body (1) main pin (2) central connector

The swing linkage of the snow plough must be set so that when the snow plough rests on the ground the range of the snow plough body movement relative to the linkage during ground surface tracking is 2/3 down and 1/3 up of the total stroke. When working with the swing linkage

snow plough, make sure that the carrying vehicle linkage is fixed; do not work in a floating position.

ADJUSTING THE SNOW PLOUGH WORKING POSITIONS

The snow plough has four adjustable working positions. In order to change the snow plough working position use the control panel (1) (Figure 4.4) and the manifold lever (2) that controls a relevant section of the external hydraulic system of the carrying vehicle.

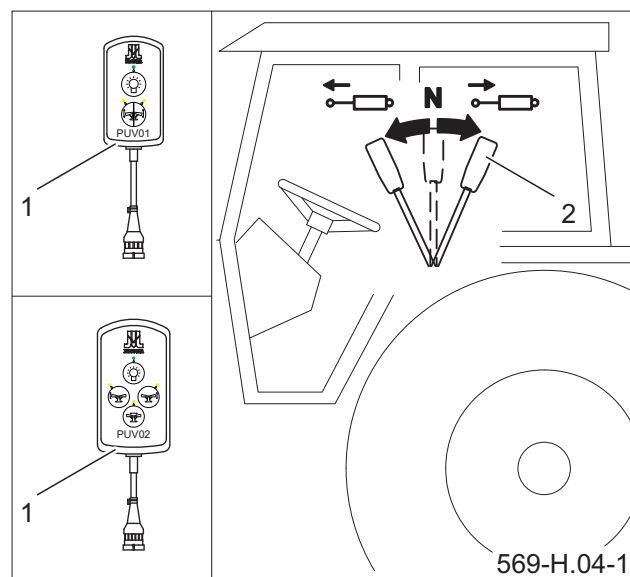

Figure 4.4 Controlling the snow plough (1) control panel (2) manifold lever

The snow plough can be equipped with a panel of independent control or a panel of independent-simultaneous control (Figure 4.5).

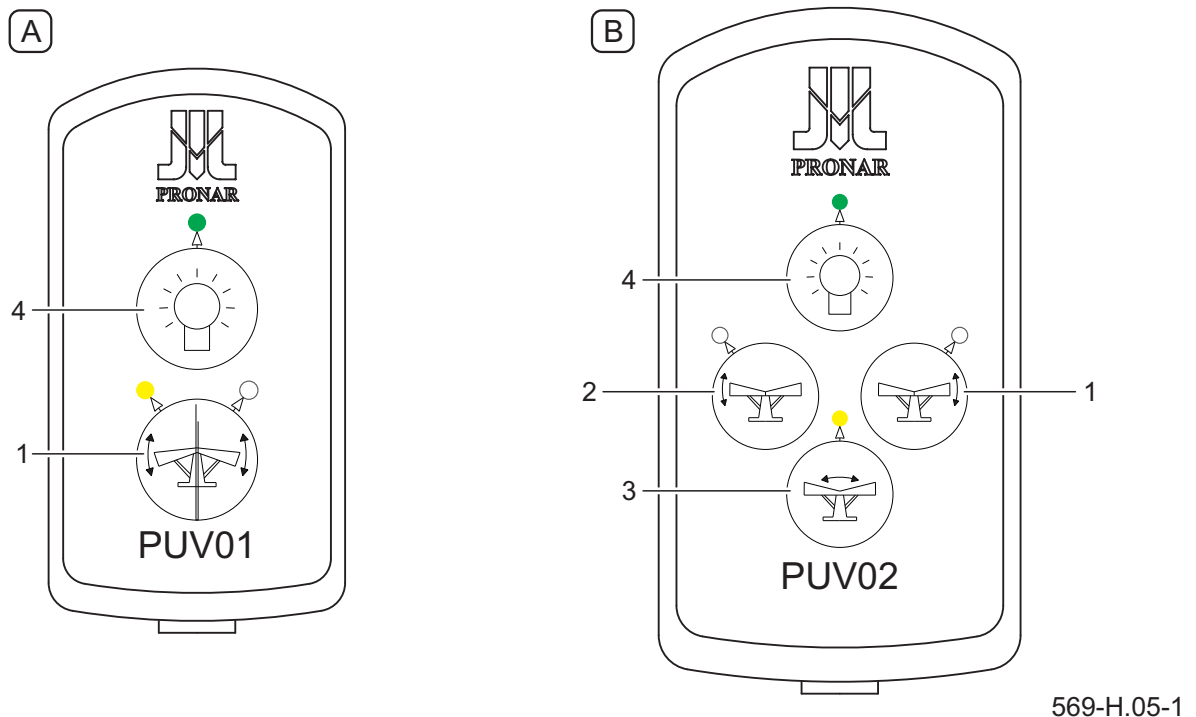

Figure 4.5 Control panel

(A) panel of independent control (B) panel of independent-simultaneous control

(1) (2) (3) push-buttons for controlling the right and the left snow plough wing (4) push-button for switching the lights on

On the panel of independent control (A) there is a control push-button (1) and a push-button for switching the lights on (4). In this case, the hydraulic system can control alternately the right or the left snow plough wing. After turning power on, the left wing control function activates and corresponding LED lights up. Press the push-button to switch the function and

press the push-button again to return to the current function.

On the panel of independent-simultaneous control (B), there are control push-buttons (1), (2), (3) and a push-button for switching the lights on (4). After turning power on, the simultaneous control function activates and corresponding LED lights up. The right or the left snow plough wing can be controlled alternately by pressing push-button (1) or (2). If push-button (3) is ON, the right and the left snow plough wings can be controlled simultaneously.

The panels are equipped with timer



DANGER

The snow plough is controlled from the operator cab.
When the machine is in use there must be no bystanders near the machine.

switches, which, after 10 minutes (panel A) and 30 minutes (panel B), switch the function to the initial condition (to prevent heating of the solenoid valve coils).

Working speed of the machine depends on the type and quantity of collected material but also on the type of terrain.

**ATTENTION**

It is not recommended to operate the machine in heavy duty conditions with a speed exceeding 6 km/h.

**ATTENTION**

Do NOT operate the snow plough while reversing. While reversing raise the machine.

SETTING THE WORKING HEIGHT

The slides or wheels are used in order to maintain a proper distance between the ground and collecting blades, to reduce thickness of scraped material layer and to limit the depth of blade sinking into soft ground.

In the snow ploughs equipped with slides (Figure 4.6), the working height adjustment is performed by loosening nut (2) and bolt (3) and proper extension or withdrawal of slide (1) in guide. When the height is set, secure the slide by tightening bolt (3) and nut (2). Adjustment of the left slide and the right slide is carried out in the same way.

Slides of the left and right wing should be put forward at the same height. The recommended distance of the collecting strips from the cleared surface is $5 \div 12$ mm.

In the snow ploughs equipped with wheels (Figure 4.7), the working height adjustment is performed by means of washers (3). To do this, take out pin (2) and remove wheel with washers (1). When a proper height is set, secure the wheel with pin (2). Location of the wheel in the guide can be changed every 6 mm. Adjustment of the left wheel and the right wheel is carried out in the same way. Both wheels should be set at the same height.

**DANGER**

Setting the working height should be performed only when the carrying vehicle's engine is stopped, and the machine is raised and secured.

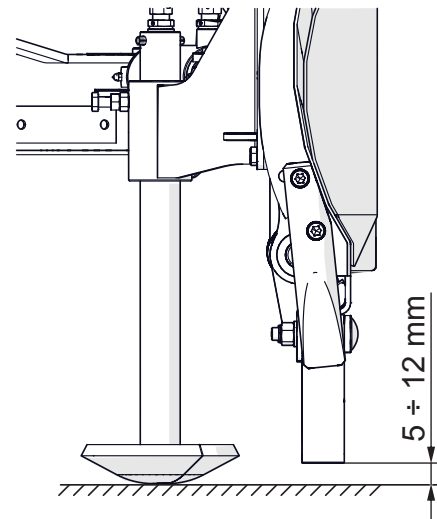
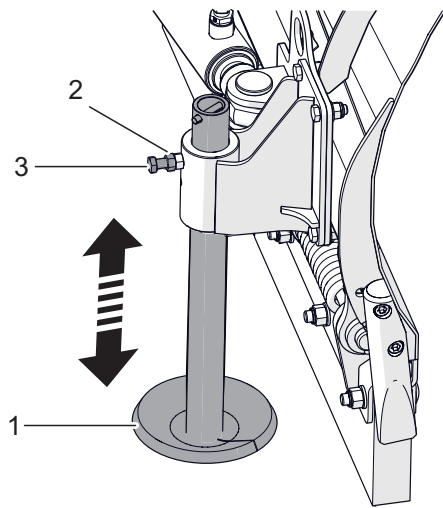

569-H.06-1

Figure 4.6 Working height adjustment in the snow ploughs equipped with slides
 (1) slide (2) nut (3) bolt

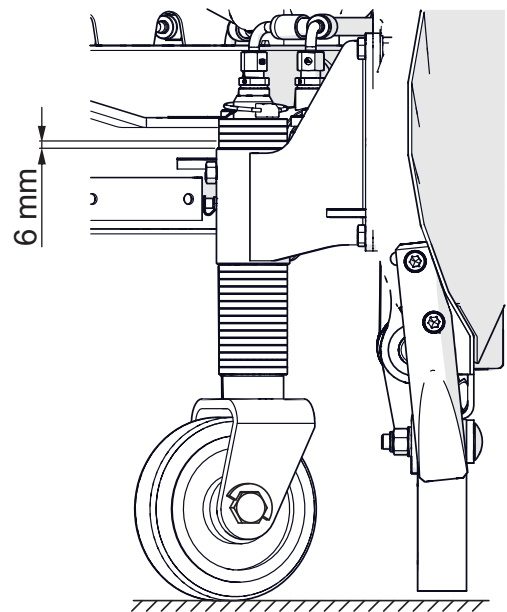
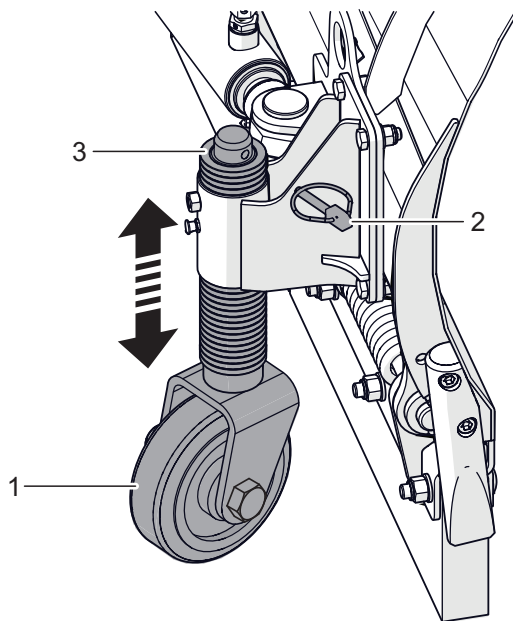

569-H.07-1

Figure 4.7 Working height adjustment in snow ploughs equipped with wheels.
 (1) wheel (2) pin (3) washer

H.2.2.569.04.1.EN

4.5 DRIVING ON PUBLIC ROADS

When driving on public roads, respect the road traffic regulations, exercise caution and prudence. If the clearing with machine is done on a pavement or promenade special attention should be paid to the bystanders likely to be near the working machine. Listed below are the key guidelines.

- Before moving off make sure that there are no bystanders, especially children, near the machine and the carrying vehicle. Ensure that the driver has sufficient visibility.
- Make sure that the machine is correctly attached to the carrying vehicle, and linkage is properly secured.
- While driving or operating the machine on public roads turn on clearance lamps,
- The maximum working speed and the maximum speed allowed by road traffic regulations must not be exceeded. Speed of travel should be adjusted to prevailing road conditions and other conditions.
- While driving on public roads turn on the lights.
- While working with the snow plough, turn on the orange beacon light (included in the carrying vehicle equipment).
- Avoid ruts, depressions, ditches or driving on roadside slopes. Driving across such obstacles could cause the machine and the carrying vehicle to suddenly tilt. Driving near ditches or canals is dangerous as there is a risk of the slope collapsing.
- Speed must be sufficiently reduced before making a turn or driving on an uneven road or a slope.
- When driving on uneven terrain with the snowplough raised reduce speed due to dynamic loads and the risk of damaging the machine or carrying vehicle.

H.2.2.569.05.2.EN

4.6 UNHITCHING THE MACHINE FROM CARRYING VEHICLE

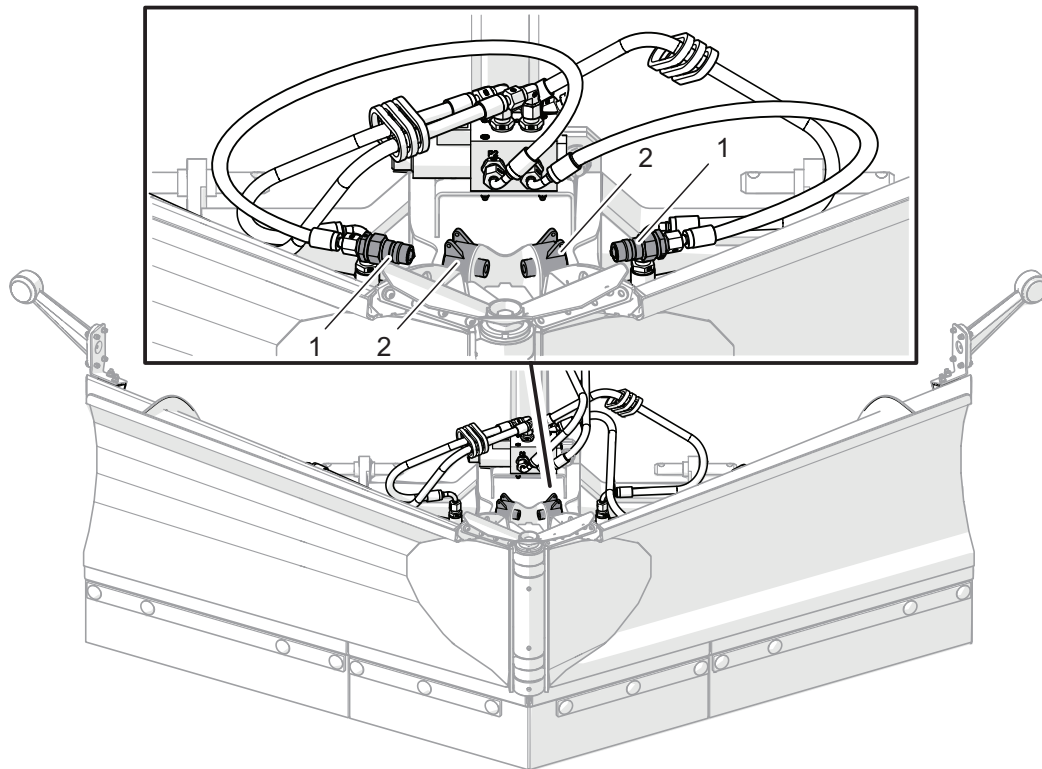

569-H.08-1

Figure 4.8 Protection of hydraulic quick couplers
 (1) hydraulic quick coupler (2) protective socket

In order to disconnect the snow plough from the carrying vehicle, proceed as follows:

- position plough so that wings are folded to the rear (Figure 4.8),
- lower the snow plough until it fully rests on the ground,
- turn off the carrying vehicle's engine, engage the parking brake,
- reduce residual pressure in the hydraulic system by movement of appropriate lever controlling hydraulic circuit,
- disconnect hydraulic conduit plugs from the carrying vehicle and electric power lead of the solenoid valve and clearance lights,
- quick couplers of hydraulic conduits (1) must be protected against contamination and inserted in special sockets (2) on the snow plough frame,
- disconnect the snow plough from the carrying vehicle's linkage,
- after disconnecting from the carrying vehicle, the snow plough should rest on the ground leaning against

collecting strips and slides or supporting wheels (option).

**DANGER**

Before unhitching from the carrying vehicle, position the snow plough so that the wings are folded to the rear.

Reduce pressure prior to disconnecting the hydraulic system.

H.2.2.569.06.1.EN

SECTION 5

MAINTENANCE

5.1 CHECKING AND REPLACEMENT OF COLLECTING BLADES

! DANGER

Before commencing any maintenance work, reduce residual pressure in the hydraulic system.

! DANGER

Do NOT perform maintenance or repair work under raised and unsupported machine.

Excessively worn or damaged collecting blades must be replaced. List of blades is shown in specific tables.

! DANGER

During inspection and replacement of the blades, turn off the carrying vehicle's engine and remove the key from the ignition.

Before replacing collecting blades raise the plough and support with sufficiently stable and strong supports. If the snow plough is hitched and raised on the front three-point linkage, protect it from falling and immobilise the carrying vehicle (turn off the engine and engage the parking brake.)

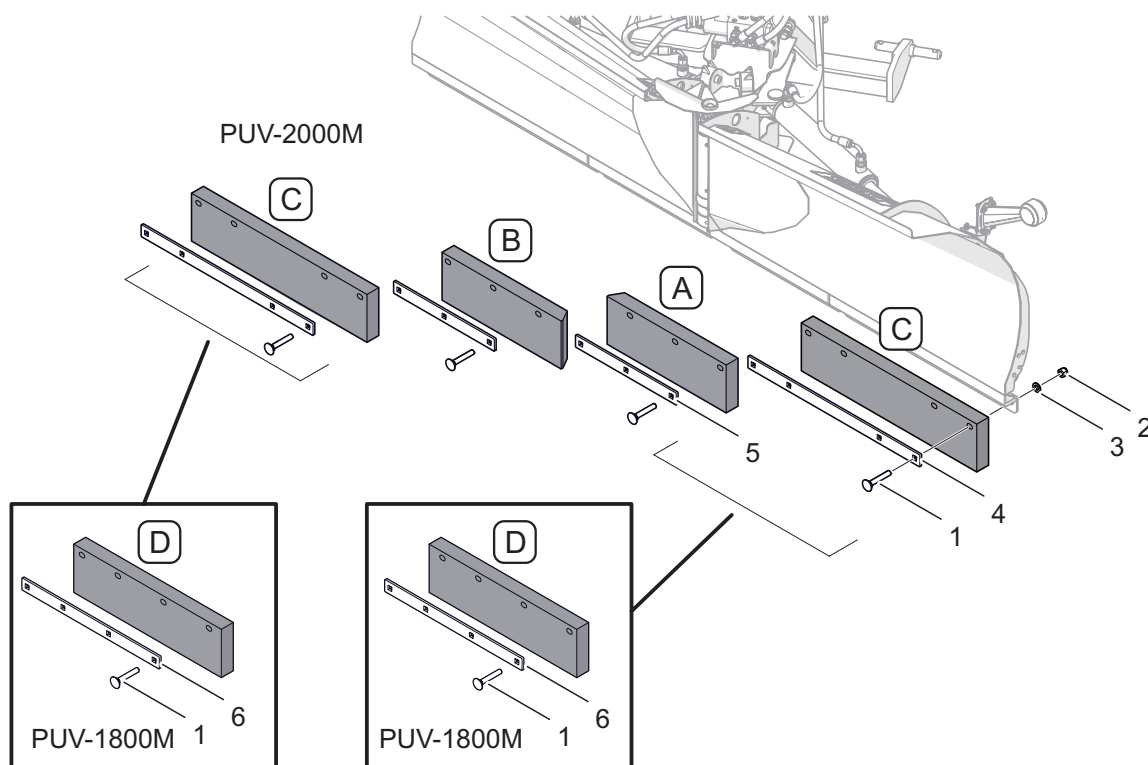

569-I.01-1

Figure 5.1 Replacement of rubber blades

(A) left internal blade

(B) right internal blade

(C)(D) external blade

(1) bolt

(2) nut

(3) washer

(4) external clamping strip

(5) internal clamping strip

(6) external clamping strip

Table 5.1 Rubber snow plough blades

Marking Figure 5.1	Name / catalogue No.	Number of items	
		PUV-1800M	PUV-2000M
A	Internal left blade / 569N-03000001L	1	1
B	Internal right blade / 569N-03000001P	1	1
C	External blade / 569N-03000002	-	2
D	External blade / 571N-03000001	2	-

Rubber blades consist of segments (A - D) (1), washers (3) and sleeves (4). (Figure 5.1). To dismount a blade segment, undo proper nuts (2), take out fixing bolts (1) and washers (3) and remove clamping strips (4 - 6). Install a new blade in reverse order.

Steel blades consist of segments (A - C) (Figure 5.2). To dismount a blade segment, undo proper nuts (2), take out fixing bolts

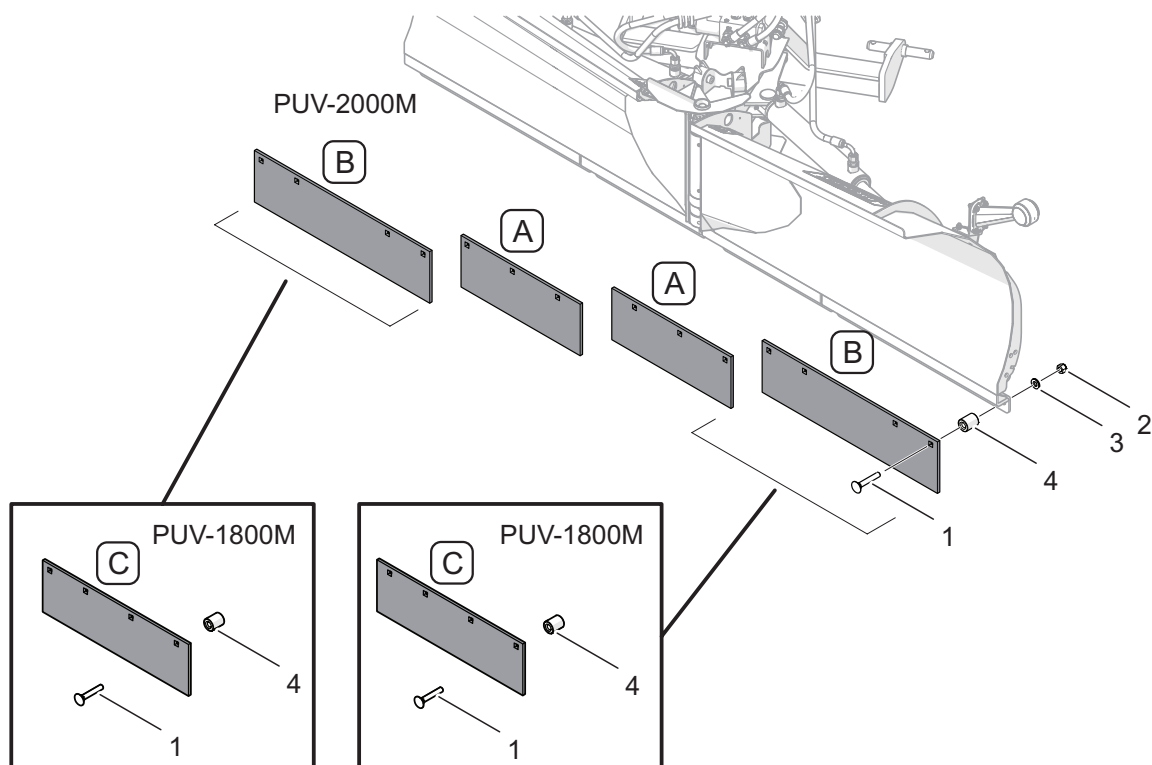

569-I.02-1

Figure 5.2 Replacement of vertical steel blades
 (A) internal blade (B) external blade (C) external blade
 (1) bolt (2) nut (3) washer (4) sleeve

Table 5.2 Vertical steel snow plough blades

Marking Figure 5.2	Name / catalogue No.	Number of items	
		PUV-1800M	PUV-2000M
A	Internal blade / 569N-10000002	2	2
B	External blade / 569N-10000003	-	2
C	External blade / 571N-04000001	2	-

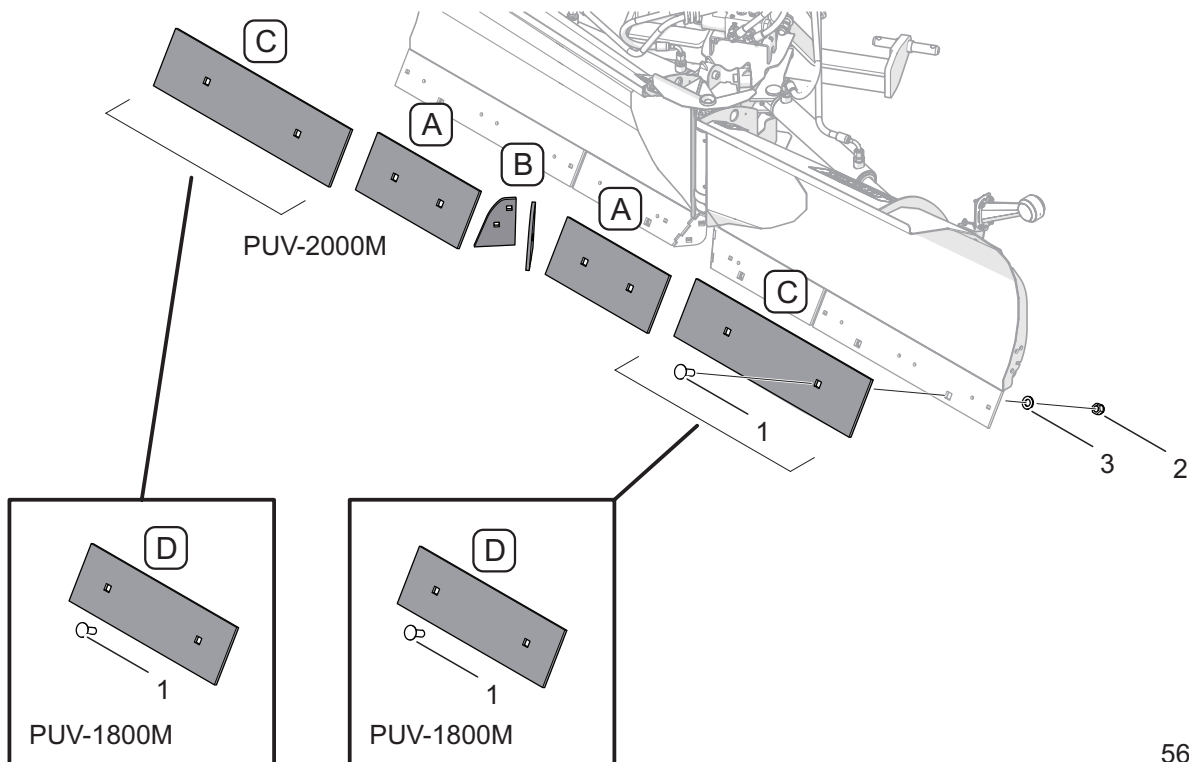
**Figure 5.3** Replacement of steel blades set at the angle of 60°

(A) blade

(B) internal blade

(C)(D) external blade

(1) bolt

(2) nut

(3) washer

Table 5.3 Steel blades set at the angle of 60°

Marking Figure 5.3	Name / catalogue No.	Number of items	
		PUV-1800M	PUV-2000M
A	Blade / 569N-11000003	2	2
B	Internal blade / 569N-11000002	2	2
C	External blade / 569N-11000001	-	2
D	External blade / 571N-05000001	2	-

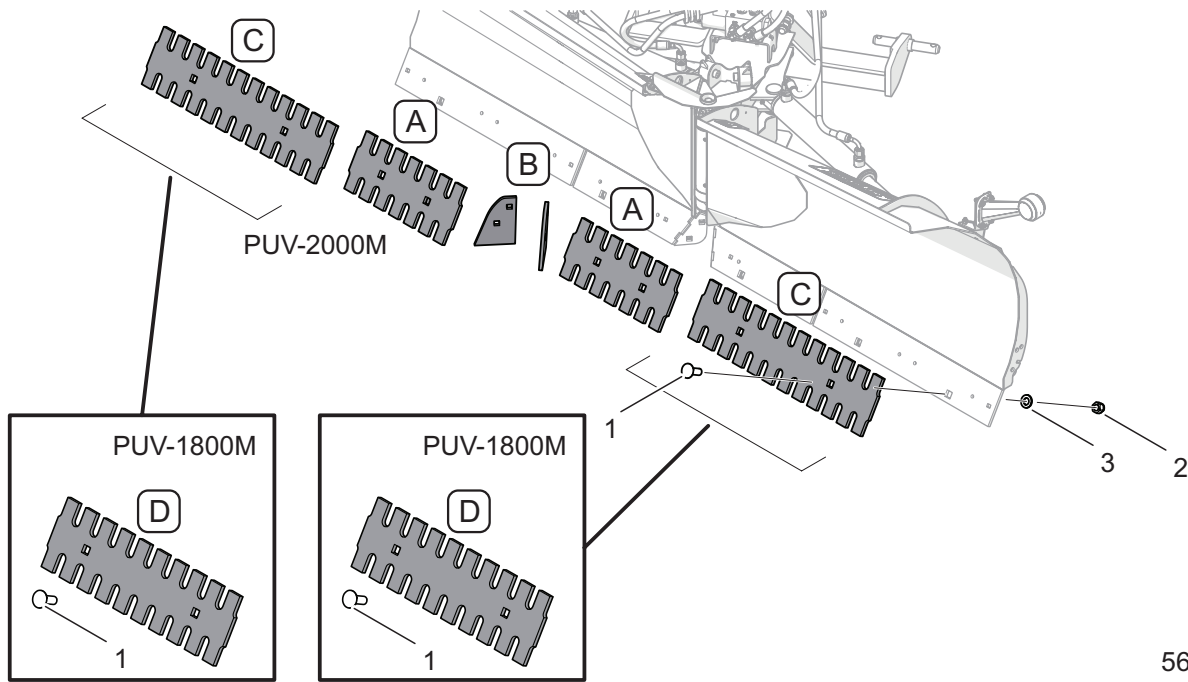

569-I.04-1

Figure 5.4 Replacement of perforated steel blades set at the angle of 60°
 (A) blade (B) internal blade (C)(D) external blade
 (1) bolt (2) nut (3) washer

Table 5.4 Perforated steel blades set at the angle of 60°

Marking Figure 5.4	Name / catalogue No.	Number of items	
		PUV-1800M	PUV-2000M
A	Blade / 569N-13000002	2	2
B	Internal blade / 569N-11000002	2	2
C	External blade / 569N-13000001	-	2
D	External blade / 571N-06000001	2	-

The steel blades set at the angle of 60° and perforated steel blades set at the angle of 60° that are worn on one side can be turned on the other side and reinstalled on the snow plough.

i TIP
 Tighten (M12) bolt and nut connections of steel blades using the tightening torque of 100 Nm, and tighten (M16) bolt and nut connections using the tightening torque of 240 Nm.

I.2.2.569.01.1.EN

5.2 REPLACEMENT OF FENDERS

Technical condition of fenders should be checked periodically. Damaged fenders should be replaced with new ones.

Depending on type of collecting blades,

the snow plough can be equipped with fenders for vertical blades (A) or fenders for blades set at the angle of 60° to the ground (B).



DANGER

During inspection and replacement of the fenders, turn off the carrying vehicle's engine and remove the key from the ignition.



TIP

Bolt and nut connections of fenders should be tightened using the tightening torque of 55 Nm.

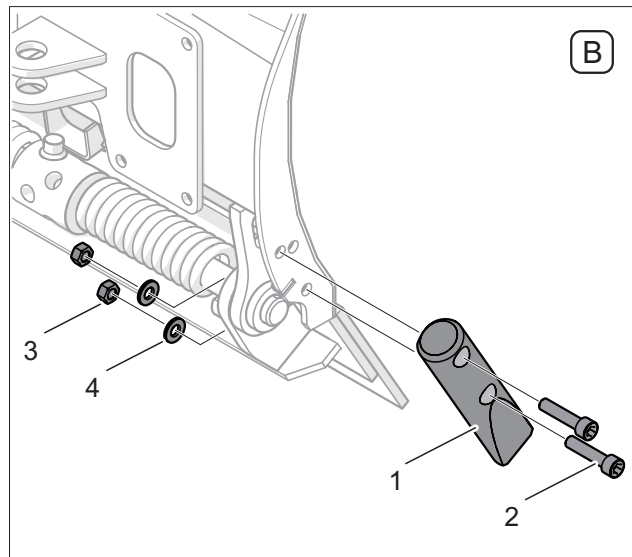
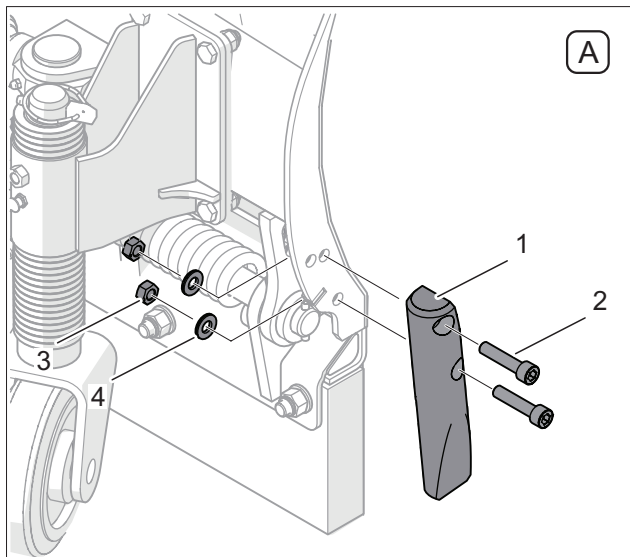

569-I.05-1

Figure 5.5 Replacement of blade fenders

(A) fenders for vertical blades (B) fenders for the blades set at the angle of 60° to the ground

(1) fender

(2) bolt

(3) nut

(4) washer

Table 5.5 Fenders of collecting blades

Marking Figure 5.5	Name / catalogue No.	Number of items	
		PUV-1800M	PUV-2000M
A	Left fender of the blade / 569N-09000001L	1	1
	Right fender of the blade / 569N-09000001P	1	1
B	Fender / 569N-15000001	2	2

I.2.2.569.02.1.EN

5.3 SLIDES REPLACEMENT



DANGER

Replacement of slides should be performed only when the carrying vehicle's engine is stopped, and the machine is raised and secured.

Excessively worn or damaged slide elements must be replaced (Figure 5.6). In order to do this, raise the snow plough and support it with sufficiently stable and strong supports. If the snow plough is hitched and raised on the front three-point linkage, protect it from falling and immobilise the carrying vehicle (turn off the engine and engage the parking brake.) Loosen nut (4) and bolt (3) and take out spring pin (2) and then remove slide (1) from guide. Check the slide and other elements for damage or excessive wear.

The list of slide working components including catalogue numbers is shown in

Table 5.6 List of slide working components

Marking Figure 5.6	Name / catalogue No.	Number of items	
		PUV-1800M	PUV-2000M
1	Slide / 569N-14010000	1	1
2	Spring pin 8x50-C / PN-EN ISO 8752	1	1
3	Bolt M10x30-8.8-A2J / PN-EN ISO 4017	1	1
4	Nut M10-8-A2J / PN-EN ISO 4032	1	1

TABLE 5.6 Quantities of parts for one slide are given in the table.

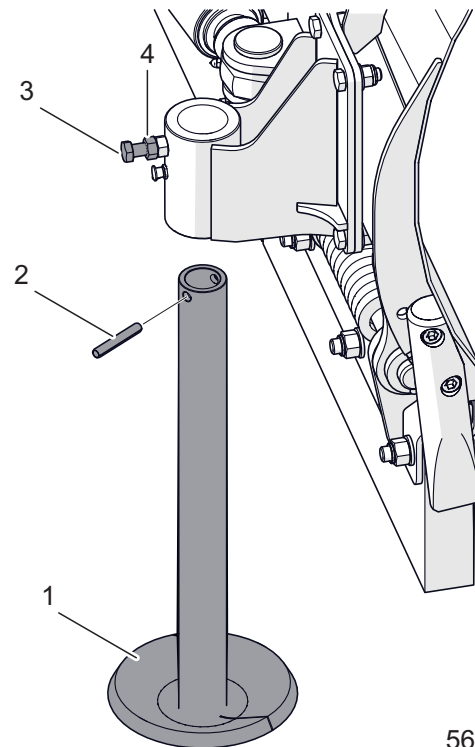

569-I.06-1

Figure 5.6 Slide replacement

(1) slide
(3) bolt

(2) spring pin
(4) nut

I.2.2.569.03.1.EN

5.4 ADJUSTMENT OF COLLECTING BLADE SPRINGS



DANGER

Adjustment of blade springs should be performed only when the carrying vehicle's engine is stopped, parking brake is engaged and the machine is raised and secured.

Before starting the adjustment, the snow plough should be mounted on the carrying vehicle, raised and secured against falling. Tension of springs is adjusted by means of tightening sleeves. Make the adjustment using a steel bar with a proper diameter.

To tighten the snow plough blades' springs (Figure 5.7):

- A) Insert rod (3) into proper opening of tightening sleeve (1).
- B) Turn the tightening sleeve using rod (3) to enable removal of locking pin (2)
- C) Turn the sleeve (1) downwards and hold it in this position.

Insert the locking pin (2) into proper opening of the sleeve (1) and turn the tightening sleeve (1) so that the locking pin (2) is supported on the bumper.

Repeat actions (A), (B), (C), (D) until proper spring tension is obtained.

The adjustment should be performed individually, in the same way, for each spring.

The pin should be relocated by the same number of openings in each sleeve (maximally by 8 openings from the loose, un-tightened position). To reduce the spring tension, turn the sleeve in the opposite direction.



TIP

Before making the adjustment, clean the springs and tightening sleeves.

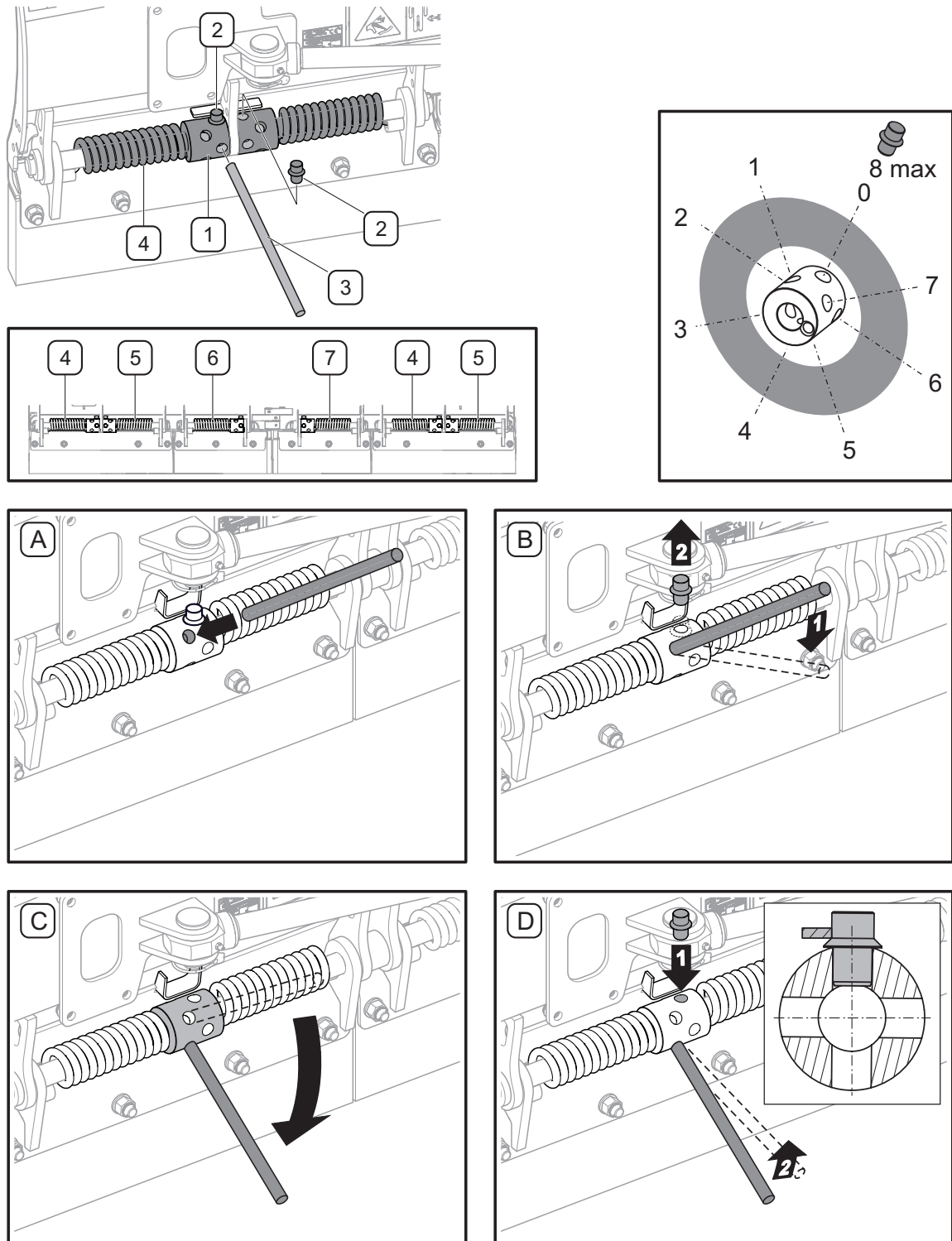

569-I.07-1

Figure 5.7 Adjustment of collecting blade springs
 (A)(B)(C)(D) sequence of actions (1) tensioning sleeve
 (2) locking mandrel
 (3) rod (4)(5)(6)(7) spring

(2) locking mandrel

I.2.2.569.04.1.EN

5.5 HYDRAULIC SYSTEM MAINTENANCE



DANGER

Do not repair hydraulic system on your own. All hydraulic system repairs must be performed only by suitably qualified personnel.

The duties of the operator connected with the hydraulic system maintenance include:

- checking tightness of cylinders and hydraulic connections,
- checking technical condition of hydraulic conduits;
- checking technical condition and leak tightness of hydraulic connectors.



ATTENTION

Before starting work, visually inspect the hydraulic system components.

The hydraulic system of new machine is factory filled with HL32 hydraulic oil. Because of its composition, the oil is not classified as a dangerous substance, however long-term action on the skin or eyes may cause irritation. In the event of contact of oil with skin wash the place of contact with water and soap. Do NOT apply organic solvents (petrol, kerosene). Contaminated clothing should be changed to prevent access of oil to skin. In the event of contact of oil with eye, rinse with large quantity of water and in the event of the occurrence of irritation consult a doctor. Hydraulic oil in normal conditions is not harmful to the respiratory tract. A hazard only occurs when oil is strongly atomised (oil vapour), or in the case of fire during which toxic compounds may be released.

Table 5.7 HL32 hydraulic oil characteristics

Item	Name	Value
1	ISO 3448VG viscosity classification	32
2	Kinematic viscosity at 40°C	28.8 – 35.2 mm ² /s
3	ISO 6743/99 quality classification	HL
4	DIN 51502 quality classification	HL
5	Flash point, °C	Above 210°C
6	Maximum operating temperature, °C	80

**DANGER**

Oil fires should be quenched with carbon dioxide (CO₂), foam or extinguisher steam. Do NOT use water for fire extinguishing!

Spilt oil should be immediately collected and placed in a marked tight container. Used oil should be taken to the appropriate facility dealing with recycling or re-generation of oils.



The condition of hydraulic system should be inspected regularly while using the machine.

The machine's hydraulic system should be completely tight sealed. Inspect the seals when the hydraulic cylinder is completely extended. If oil leak is detected on hydraulic cylinder body, ascertain origin of leak. Minimum leaks are permissible with symptoms of "sweating", however in the event of noticing leaks in the form of "droplets" stop using the machine until faults are remedied.

**DANGER**

Before commencing whatever work on hydraulic system reduce the residual pressure in the system.

During work on hydraulic system, use the appropriate personal protection equipment i.e. protective clothing, footwear, gloves and eye protection. Avoid contact of skin with oil.

In the event of oil leak on hydraulic conduit connections, tighten the connection, and if this does not remedy faults then change conduit or connection elements. Always exchange each mechanically damaged component.

**ATTENTION**

The hydraulic system is vented automatically during machine operation.



Hydraulic conduits should be replaced after 4 years of machine use.

I.2.2.569.05.1.EN

5.6 ELECTRICAL SYSTEM MAINTENANCE

Electrical system maintenance involves periodical checking the operation of the clearance lights system and hydraulic solenoid valve. After hitching the machine to the carrying vehicle, connect power lead of the electrical system and control panel wiring harness.

Place the control panel in the operator's cab. Connect hydraulic conduits to the connectors of the carrying vehicle's

external hydraulic system. Check operation of clearance lights and individual functions of the machine.

The snow plough's clearance lights are maintenance-free LED lights.



DANGER

Do not repair electric system on your own. All electric system repairs must be performed only by suitably qualified personnel.

I.2.2.569.06.1.EN

5.7 LUBRICATION



DANGER

Lubrication may only be performed when the snowplough is lowered, and resting on the ground.

Before lubricating, switch off the carrying vehicle's engine, remove key from ignition and engage parking brake.



When using the machine the user is obliged to observe lubrication instructions according to attached schedule. Excess lubricant causes depositing of additional contaminants in places requiring lubrication, therefore it is essential to keep individual machine components clean.

Machine lubrication should be performed with the aid of a manually or foot operated grease gun, filled with generally available grease. Before commencing lubrication insofar as is possible remove old grease and

other contamination. Remove and wipe off excess oil or grease ŁT-43-PN/C-96134 grease is recommended for lubrication.

Table 5.8 Lubrication points and lubrication frequency

Item	Name	Number of lubrication points	Type of grease	Lubrication frequency
A	Blade main pivot pin	4	grease	50 hours
B	Hydraulic cylinder eye	2+2		50 hours
C	Wheel sleeve*	1+1		50 hours
D	Linkage skid plate swinging (option)	2		20 hours

* – if wheels are installed

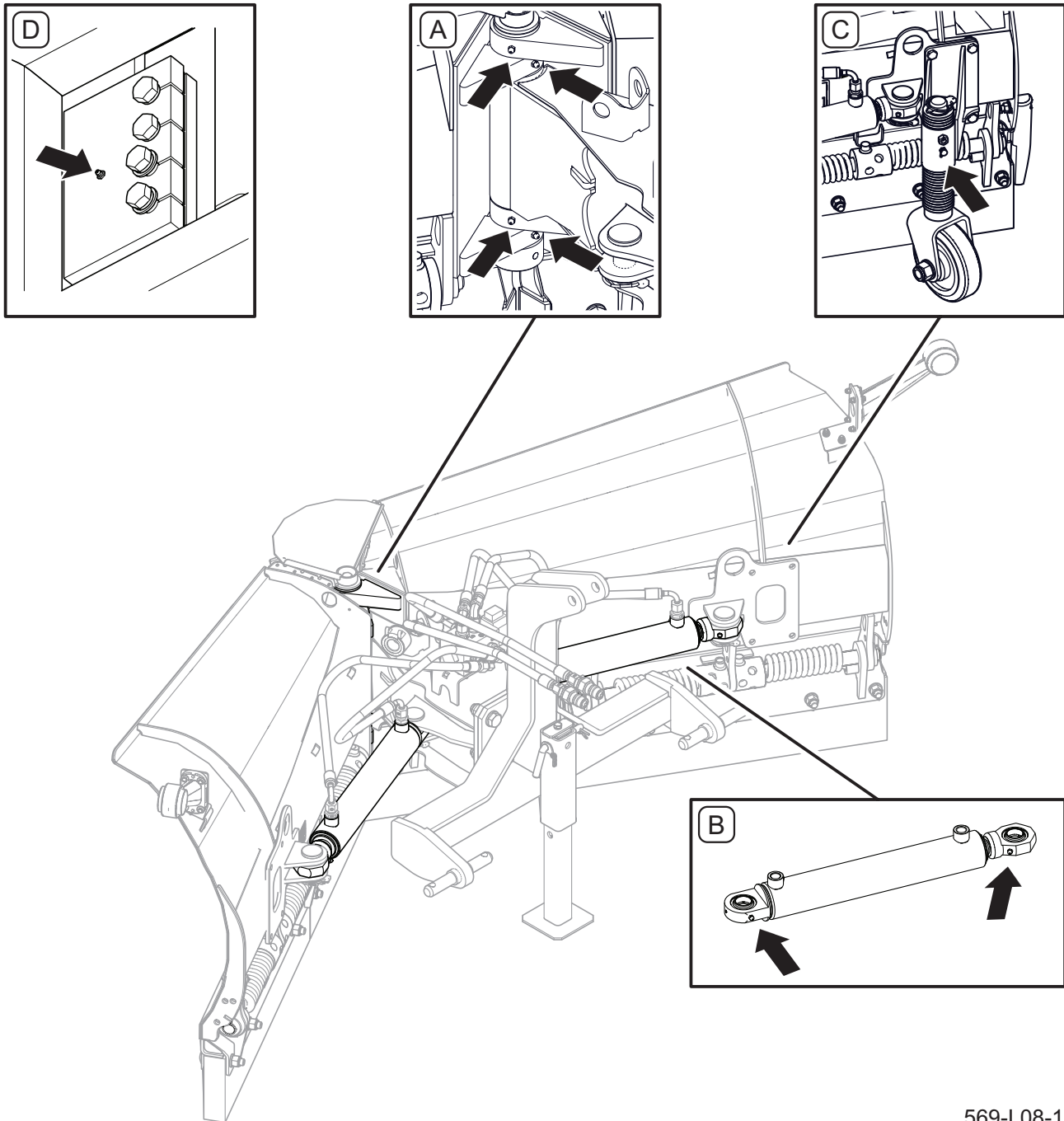

569-I.08-1

Figure 5.8 Lubrication points
Lubrication points are detailed in TABLE 5.8

I.2.2.569.07.1.EN

5.8 STORAGE

After finishing work, the machine should be thoroughly cleaned and washed with a water jet. While washing, do not direct a strong water or steam jet at information and warning decals or hydraulic conduits and electrical components. Nozzle of pressure or steam washer should be kept at a distance of not less than 30 cm from cleaned surface.

After cleaning, inspect the whole machine, inspect technical condition of individual elements. Used or damaged elements should be repaired or replaced.

In the event of damage to the paint coat, clean rust and dust from damaged area, degrease and then paint with undercoat and after it is dry paint with surface coat paint retaining colour uniformity and even thickness of protective coating. Until the time of touch-up painting, the damaged place may be covered with a thin layer of grease or anticorrosion preparation.

Machine should be kept in closed or roofed building.

If the machine shall not be used for a long period of time, protect it against adverse weather conditions. Lubricate machine according to the instructions provided. In the event of a prolonged work stoppage, it is essential to lubricate all components regardless of the date of the last lubrication. Additionally, before winter, apply grease to hitching system pins.

Machine disconnected from the carrying vehicle should be set in "arrow" position and on the parking stand (if installed), on level, sufficiently hard surface in such a manner as to ensure that it is possible to connect it again.

Control panel with connection lead and solenoid valve power lead should be disconnected from the machine and protected against adverse weather conditions.

I.2.2.569.08.1.EN

5.9 INSPECTION OF TIGHTENING TORQUE OF NUT AND BOLT CONNECTIONS

Unless other tightening parameters are given, during maintenance repair work apply appropriate torque to tighten nut and bolt connections. Recommended tightening torques of the most frequently used bolt and nut connections are given in the table (5.9).

Given values apply to non-lubricated steel bolts.

If you need to replace the fasteners (bolts, nuts), the lowest allowable strength class is 8.8. Do NOT use nut and bolt connections of a lower strength class.

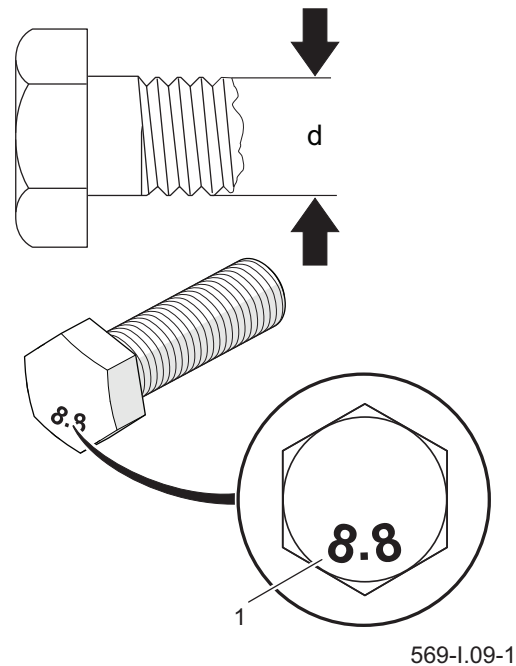

Figure 5.9 Bolt with metric thread
(1) resistance class (d) thread diameter

Table 5.9 Tightening torque for nut and bolt connections

Thread	8.8	10.9
	M [Nm]	
M10	49	72
M12	85	125
M14	135	200
M16	210	310
M20	425	610
M24	730	1 050
M27	1 150	1 650
M30	1 450	2 100

Table 5.10 Tightening torque for hydraulic conduit connections

Size of conduit	Tightening torque
DN	[Nm]
8	30÷50
10	50÷70
13	50÷70
16	70÷100
20	70÷100
25	100÷150
32	150÷200

I.2.2.569.09.1.EN

5.10 TROUBLESHOOTING

Table 5.11 Troubleshooting

TYPE OF FAULT	CAUSE	REMEDY
Snowplough position cannot be changed	Electrical system not connected to the carrying vehicle	Connect connection lead to the carrying vehicle's electrical system.
	Control panel is not connected	Connect control panel
	Hydraulic system not connected to the carrying vehicle	Connect hydraulic quick-couplers to a proper section of the carrying vehicle's hydraulic system
	Fuse is blown in the carrying vehicle	Replace the fuse in the carrying vehicle
	Defective hydraulic machine or carrying vehicle system	Repair at an authorised service point
	Defective electric system	Repair at an authorised service point
Machine removes snow unevenly	Incorrectly positioned linkage. Ground surface tracking is not possible (swing suspension).	Check and, if necessary, adjust.
	Incorrectly positioned slides or wheels (option)	Check and replace if necessary
	Excessively worn collecting snow plough blades	Check and replace if necessary
	The snow plough is not levelled	Level the snow plough
No lighting	Electrical system not connected to the carrying vehicle	Connect connection lead to the carrying vehicle's electrical system. Check connections on electric leads
	Damaged clearance lamp	Replace the lamp
	Defective electrical system	Repair at an authorised service point
	Control panel is damaged	Repair at an authorised service point
The left mould-board is moving instead of the right one (or/and vice versa)	Swapped plugs of solenoid valve coils	Swap the plugs

