



PRONAR Sp. z o.o.

17-210 NAREW, UL. MICKIEWICZA 101A, PODLASKIE PROVINCE

tel.:	+48 085 681 63 29	+48 085 681 64 29
	+48 085 681 63 81	+48 085 681 63 82
fax:	+48 085 681 63 83	+48 085 682 71 10

www.pronar.pl

OPERATOR'S MANUAL

KACPER SNOW PLOUGH

PRONAR PU-1700 / PU-2100

TRANSLATION OF THE ORIGINAL INSTRUCTIONS

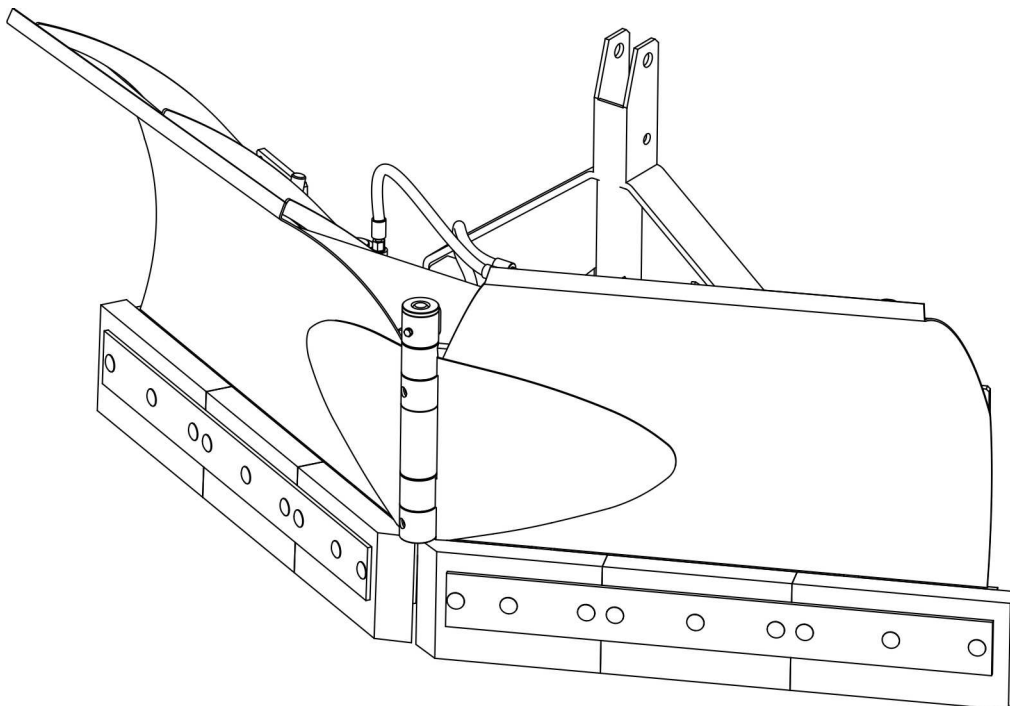

INTRODUCTION

Information contained herein is current at date of publication. As a result of improvements, some numerical values and illustrations contained in this publication may not correspond to the factual specification of the machine supplied to the user. The manufacturer reserves the right to introduce design changes in machines produced that facilitate operation and improve the quality of their work, without making minor amendments to this Operator's Manual.

This Operator's Manual is an integral part of the machine's documentation. Before using the machine, the user must carefully read this Operator's Manual and observe all recommendations. This guarantees safe operation and ensures malfunction free work of the machine. The machine is designed to meet obligatory standards, documents and legal regulations currently in force.

This Operator's Manual describes the basic safety rules and operation of PRONAR PU-1700; PU-2100 SNOW PLOUGH. If the information contained in the Operator's Manual needs clarification then the user should refer for assistance to the sale point where the tractor was purchased or to the Manufacturer

MANUFACTURER'S ADDRESS:

*PRONAR Sp. z o.o.
ul. Mickiewicza 101A
17-210 Narew*

CONTACT TELEPHONES

+48 085 681 63 29

+48 085 681 64 29

+48 085 681 63 81

+48 085 681 63 82

SYMBOLS APPEARING IN THIS OPERATOR'S MANUAL

Information, descriptions of danger and precautions and also recommendations and prohibitions associated with user safety instructions are marked:



and also preceded by the word "**DANGER**". Failure to observe the instructions may endanger the machine operator's or other person's health or life.

Particularly important information and instructions, the observance of which is essential, are distinguished in the text by the sign:



and also preceded by the word "**ATTENTION**". Failure to observe the instructions may lead to damage to the machine as a result of improper operation, adjustment or use.

In order to focus the user's attention on the need to perform maintenance, the relevant section of the Operator's Manual is marked with the pictogram:



Additional tips and advice for machine operation are marked:



and also preceded by the word „**TIP**”.

DIRECTIONS USED IN THIS OPERATOR'S MANUAL

Left side – side to the left hand of the operator facing in the direction of machine's forward travel.

Right side – side to the right hand of the operator facing in the direction of machine's forward travel.



PRONAR Sp. z o.o.

ul. Mickiewicza 101 A
17-210 Narew, Polska

tel./fax (+48 85) 681 63 29, 681 63 81, 681 63 82,
681 63 84, 681 64 29

fax (+48 85) 681 63 83

http://www.pronar.pl

e-mail: pronar@pronar.pl

EC DECLARATION OF CONFORMITY OF THE MACHINERY

PRONAR Sp. z o.o. declares with full responsibility, that the machine:

Description and identification of the machinery		
Generic denomination and function:	Snow plough	
Type:	PU-1700	PU-2100
Model:	–	–
Serial number:		
Commercial name:	Snow plough PRONAR Kacper PU-1700 Snow plough PRONAR Kacper PU-2100	

to which this declaration relates, fulfills all the relevant provisions of the Directive **2006/42/EC** of The European Parliament and of The Council of 17 May 2006 on machinery, and amending Directive 95/16/EC (Official Journal of the EU, L 157/24 of 09.06.2006).

The person authorized to compile the technical file is the Head of Research and Development Department at PRONAR Sp. z o.o., 17-210 Narew, ul. Mickiewicza 101A, Poland.

This declaration relates exclusively to the machinery in the state in which it was placed on the market, and excludes components which are added and/or operations carried out subsequently by the final user.

Narew, the 2010-04-07

Place and date

Z-CIA DYREKTORA
d/s technicznych
członka zarządu
Roman Omelianiuk

Full name of the empowered person
position, signature

TABLE OF CONTENTS

1	BASIC INFORMATION	1.1
1.1	IDENTIFICATION	1.2
1.2	PROPER USE	1.3
1.3	OPTIONAL EQUIPMENT	1.5
1.4	WARRANTY TERMS	1.5
1.5	TRANSPORT	1.6
1.6	ENVIRONMENTAL HAZARDS	1.9
1.7	WITHDRAWAL FROM USE	1.9
2	SAFETY ADVICE	2.1
2.1	BASIC SAFETY RULES	2.2
2.1.1	USE OF MACHINE	2.2
2.1.2	LINKING AND DISCONNECTING FROM TRACTOR	2.3
2.1.3	HYDRAULIC SYSTEM	2.3
2.1.4	TRANSPORTING THE MACHINE	2.4
2.1.5	MAINTENANCE	2.5
2.1.6	PLOUGH OPERATION	2.6
2.2	DESCRIPTION OF MINIMAL RISK	2.7
2.3	INFORMATION AND WARNING DECALS	2.8
3	DESIGN AND OPERATION	3.1
3.1	TECHNICAL SPECIFICATION	3.2
3.2	GENERAL DESIGN	3.4
3.3	HYDRAULIC SYSTEM	3.5
3.4	ELECTRICAL SYSTEM	3.6

4	CORRECT USE	4.1
4.1	PREPARING FOR WORK	4.2
4.2	CHECKING TECHNICAL CONDITION	4.4
4.3	HITCHING TO CARRYING VEHICLE	4.5
4.3.1	HITCHING TO THE THREE POINT LINKAGE	4.7
4.3.2	HITCHING TO FRONT LOADER	4.9
4.4	CONNECTING HYDRAULIC AND ELECTRICAL SYSTEM	4.11
4.5	PLOUGH OPERATION	4.14
4.5.1	LEVELLING PLOUGH BODY	4.14
4.5.2	ADJUSTING PLOUGH WORKING POSITIONS	4.15
4.5.3	SETTING COLLECTING STRIPS INCLINATION ANGLE	4.16
4.5.4	SETTING WORKING HEIGHT	4.17
4.6	DRIVING ON PUBLIC ROADS	4.18
4.7	DISCONNECTING THE PLOUGH	4.19
5	MAINTENANCE	5.1
5.1	CHECKING AND REPLACEMENT OF COLLECTING STRIPS	5.2
5.2	SLIDE REPLACEMENT (OPTION)	5.4
5.3	HYDRAULIC SYSTEM OPERATION	5.6
5.4	LUBRICATION	5.8
5.5	STORAGE	5.9
5.6	TIGHTENING TORQUE FOR NUT AND BOLT CONNECTIONS	5.10
5.7	TROUBLESHOOTING	5.11

SECTION

1

**BASIC
INFORMATION**

1.1 IDENTIFICATION

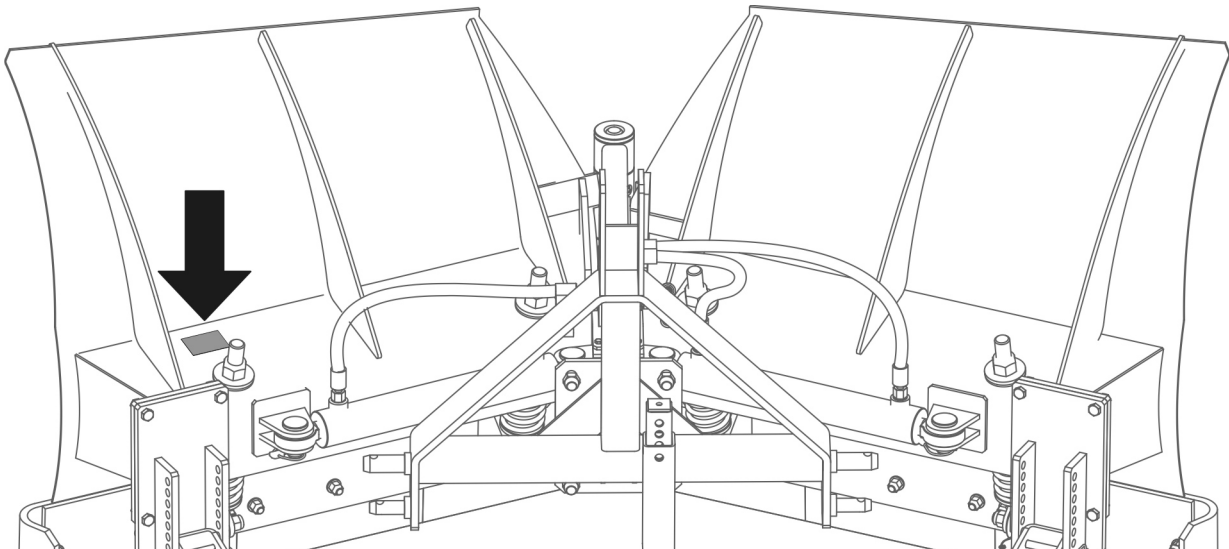
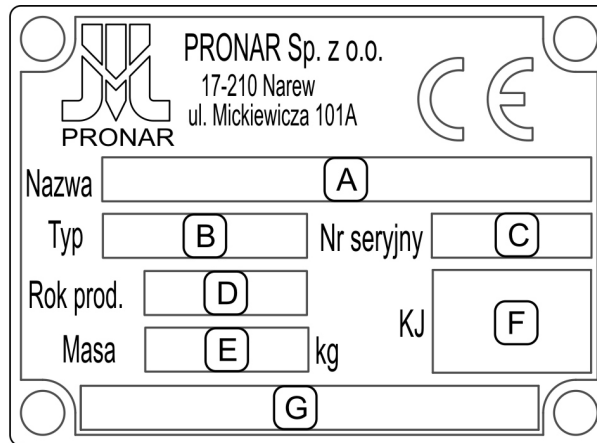

FIGURE 1.1 Location of the data plate

Meaning of data plate items (FIGURE 1.1):

- A - machine name
- B – type (ie. PU-1700)
- C – serial number
- D – year of manufacture
- E – machine tare weight [kg]
- F – Quality Control stamp
- G – Unfilled box or extension of name (box A)

Serial number is stamped on the data plate. Data plate is located on the mouldboard on the left side of the machine. When buying the machine, check that the serial number corresponds with that indicated in the *WARRANTY BOOK*, in the sales documents and in the *OPERATOR'S MANUAL*.

1.2 PROPER USE

The PRONAR PU-1700 i PU-2100 snow ploughs are designed for clearing road surfaces, squares, parking spaces and all other hard road and footpath surfaces such as asphalt, concrete paving blocks, paving, concrete. Use for other purposes is not in accord with design. Depending on the equipment ploughs can be mounted on agricultural tractors, front loaders and other slow-moving vehicles that meet the requirements set out in Table 1.1.

Using it as intended also involves all actions connected with the safe and proper operation and maintenance of the machine. Due to the above, the user is obliged to:

- carefully read the *OPERATOR'S MANUAL* and comply with its recommendations,
- understand the machine's operating principle and how to operate it safely and correctly,
- comply with general safety regulations while working,
- prevent accidents,
- comply with road traffic regulations.

The machine may only be used by persons, who:

- are familiar with the contents of this publication and with the contents of the agricultural tractor (carrying vehicle) Operator's Manual,
- have been trained in machine operation and safe working conditions,
- have the required authorisation to drive and are familiar with the road traffic regulations and transport regulations.

	<p>IMPORTANT!</p> <p>The plough must not be used for purposes other than those for which it is intended, in particular:</p> <ul style="list-style-type: none"> • levelling of roads, terrain; • transport of people, animals and other items on the machine
---	--

TABLE 1.1 Agricultural tractor (carrying vehicle) requirements

	UNIT	REQUIREMENTS
Linkage		
Front three point linkage	-	category I - II in accordance with ISO 730-1, with the "floating" setting if the plough a fixed suspension system
Front loader	-	EURO mounting system
	-	ŁC-1650 mounting system
Other	-	EURO-SMS mounting system
Hydraulic system		
Hydraulic oil	-	HL32
Nominal pressure	MPa	16
Hydraulic sockets	-	2 sockets of one section on the front of the tractor (vehicle)
Electrical system		
Solenoid supply	-	2 pin sockets on the front of the vehicle or cigarette lighter
Electrical system voltage	V	12
Other requirements		
Power range	hp	25 ÷ 55
Beacon light	-	orange light

1.3 OPTIONAL EQUIPMENT

The plough equipment includes:

- Operator's Manual
- Warranty Book

1.4 WARRANTY TERMS

PRONAR Sp. z o.o., Narew guarantees the reliable operation of the machine when it is used according to its intended purpose as described in the *OPERATOR'S MANUAL*. Defects discovered during the warranty period will be removed by the Service under warranty. The repair period is specified in the *WARRANTY BOOK*.

The guarantee does not apply to those parts and sub-assemblies of the machine, which are subject to wear in normal usage conditions, regardless of the warranty period. Consumables include the following parts/sub-assemblies:

- collecting strips,
- slides,

The warranty service only applies to such cases as: mechanical damage, which is not the user's fault, factory defects of parts, etc.

In the event of damage arising from:

- mechanical damage which is the user's fault, caused by road accidents,
- by inappropriate use, adjustment or maintenance, use of the machine for purposes other than those for which it is intended,
- use of damaged or malfunctioning machine,
- repairs carried out by unauthorised persons, improperly carried out repairs,
- making unauthorised alterations to machine design,

the user will lose the right to warranty service.

**TIP**

Demand that the seller carefully and precisely fills out the *WARRANTY BOOK* and guarantee repair coupons. A missing date of purchase or sale point stamp, may make the user ineligible for any warranty repair or refund.

The user is obliged to report immediately on noticing any wear in the paint coating or traces of corrosion, and to have the faults rectified whether they are covered by the guarantee or not. Detailed guarantee regulations are contained in the Warranty Book attached to each machine.

Modification of the machine without the written consent of the Manufacturer is forbidden. In particular, do NOT weld, drill holes in, cut or heat the main structural elements, which have a direct impact on the machine operation safety.

1.5 TRANSPORT

The machine is prepared for sale completely assembled and does not require packing. Packing is only required for the machine operator's manual and electrical system components.

Delivery is either by transport on a vehicle or, after being attached to a tractor, independently. Transport of the machine is permissible connected to a carrying vehicle provided the vehicle's driver familiarises himself with the machine's Operator's Manual and particularly with information concerning safety and principles of connection and transport on public roads.

During road transport the machine should be secured on the carrier platform by certified belts or chains fitted with pulley.

When loading and unloading the machine, comply with the general principles of workplace health and safety for reloading work. Persons operating reloading equipment must have the qualifications required to operate these machines.

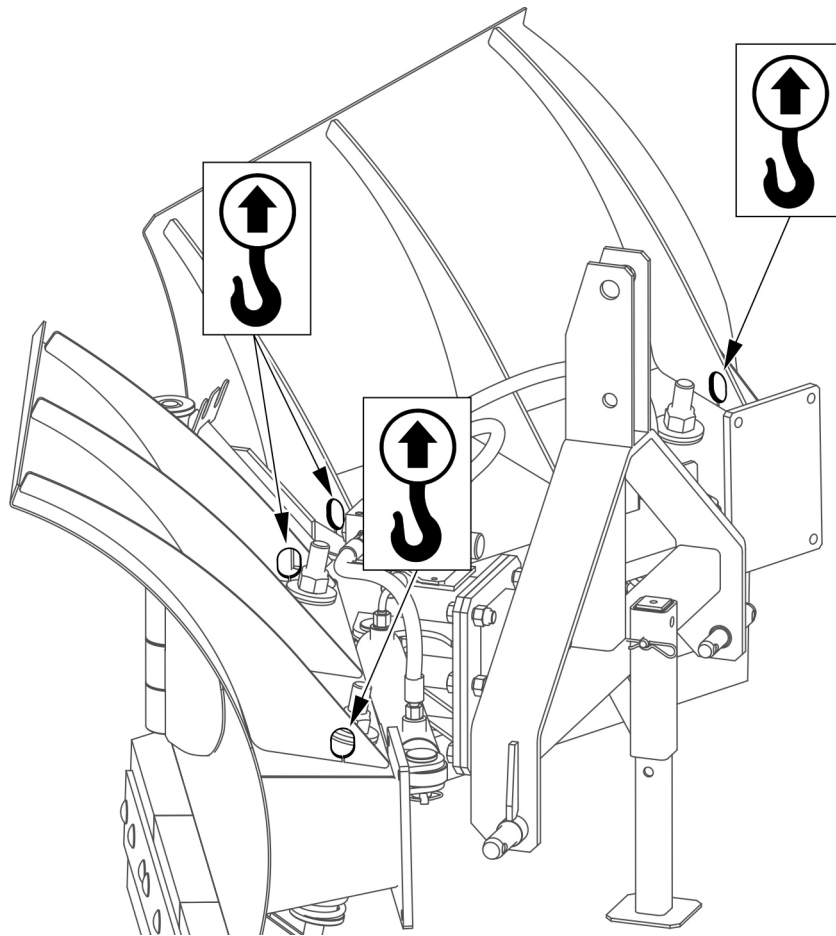

FIGURE 1.2 transport lugs

The machine should be attached to lifting equipment in places specially designed for this purpose (FIGURE 1.2), i.e. by the external and internal reinforcement of the right and left blade. Suspension points are identified with information decals. When lifting the machine take particular care due to the possibility of tipping over the machine and the risk of injuries from protruding parts. To keep lifted machine in the correct direction it is recommended to apply additional guy ropes. During the loading work particular care should be taken not to damage paint coating.

DANGER



When transporting independently, the user must carefully read this Operator's Manual and observe all recommendations. When being transported on a motor vehicle the machine must be mounted on the vehicle's platform in accordance with the transport safety requirements. The driver of the vehicle should take particular care while transporting the machine. This is due to the vehicle's centre of gravity shifting upwards when loaded with the machine.

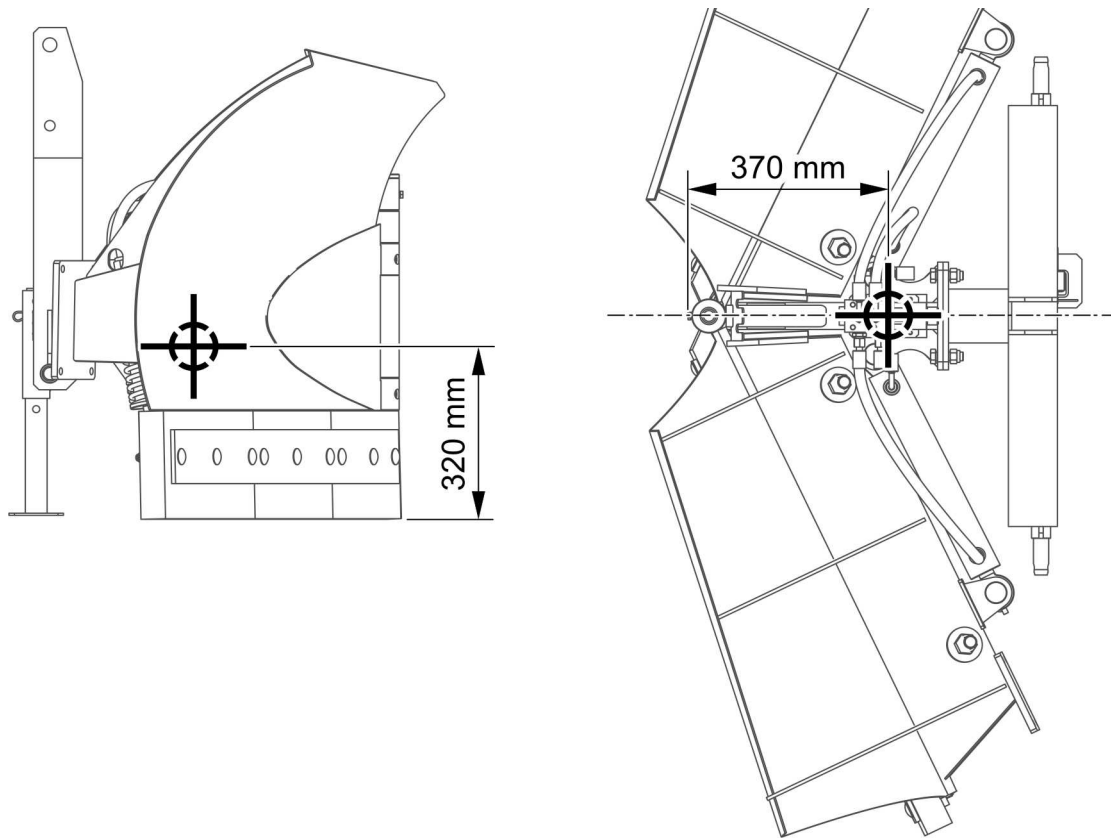

FIGURE 1.3 Centre of gravity



ATTENTION!

Centre of gravity, depending on the version (slides, various suspension systems) varies in the range ± 50 mm.



ATTENTION!

Do NOT secure brackets or any types of securing elements to hydraulic cylinders.

1.6 ENVIRONMENTAL HAZARDS

A hydraulic oil leak constitutes a direct threat to the natural environment owing to its limited biodegradability. While carrying out maintenance and repair work which involves the risk of an oil leak, this work should take place on an oil resistant floor or surface. In the event of oil leaking into the environment, first of all contain the source of the leak, and then collect the leaked oil using available means. Remaining oil should be collected using sorbents, or by mixing the oil with sand, sawdust or other absorbent materials. The oil pollution, once gathered up, should be kept in a sealed, marked, hydrocarbon resistant container, and then passed on to the appropriate oil waste recycling centre. The container should be kept away from heat sources, flammable materials and food.

Oil, which has been used up or is unsuitable for further use owing to a loss of its properties should be stored in its original packaging in the conditions described above.

1.7 WITHDRAWAL FROM USE

In the event of decision by the user to withdraw the mower from use, comply with the regulations in force in the given country concerning withdrawal from use and recycling of machines withdrawn from use.

Before proceeding to dismantle machine, oil shall be completely removed from hydraulic system.

When spare parts are changed, worn out or damaged parts should be taken to a collection point for recyclable raw materials. Waste oil and also rubber and plastic elements should be taken to establishments undertaking the utilisation of such waste.



IMPORTANT!

During dismantling personal protection equipment shall be used i.e. protective clothing, boots, gloves and protective goggles etc.

Avoid contact of skin with oil. Do not allow used oil to spill.



DANGER

Disassembly of the hydraulic system should be performed by suitably qualified personnel. Before disassembly relieve the accumulator pressure on both the liquid and gas sides.

SECTION

2

**SAFETY
ADVICE**

2.1 BASIC SAFETY RULES

2.1.1 USE OF MACHINE

- Before using the machine, the user must carefully read this Operator's Manual and the *WARRANTY BOOK*. When operating the machine, the operator must comply with the recommendations.
- The machine may only be used and operated by persons qualified to drive agricultural tractors and agricultural machines and trained in the use of the machine.
- If the information contained in the Operator's Manual is difficult to understand, contact a seller, who runs an authorised technical service on behalf of the manufacturer, or contact the manufacturer directly.
- Careless and improper use and operation of the machine, and non-compliance with the recommendations given in this operator's manual is dangerous to your health.
- Be aware of the existence of a minimal risk, and for this reason the fundamental basis for using this machine should be the application of safety rules and sensible behaviour.
- The machine must never be used by persons, who are not authorised to drive agricultural tractors, including children and people under the influence of alcohol or other drugs.
- Non-compliance with the safety rules of this Operator's Manual can be dangerous to the health and life of the operator and others.
- The machine must not be used for purposes other than those for which it is intended. Anyone who uses the machine other than the way intended takes full responsibility for himself for any consequences of this use. Use of the machine for purposes other than those for which it is intended by the Manufacturer may invalidate the guarantee.
- The machine may only be used when all the safety guards and other protective elements are technically sound and correctly positioned. In the event of loss or destruction of the safety guards, they must be replaced with new ones.

2.1.2 LINKING AND DISCONNECTING FROM TRACTOR

- Do NOT link the machine to a tractor, if hydraulic oil applied in both machines are of different types, or if the three point linkage system of the machine is not compatible with the category of the linkage system of the tractor or other carrying vehicle.
- After completion of coupling the machine, check the safeguards. Carefully read the tractor (carrying vehicle) Operator's Manual.
- To mount machine on tractor (carrying vehicle) use only genuine pins and safeguard linchpins.
- The agricultural tractor or other carrying vehicle to which the machine will be linked and coupled must be technically reliable and must fulfil the requirements of machine Manufacturer.
- Be especially careful when hitching the machine to carrying vehicle.
- When hitching, there must be nobody between the machine and the tractor. A person assisting in the hitching of the machine should stand in such a place (beyond the area of danger), in order to be continuously visible to the tractor driver.
- Exercise caution when disconnecting mower.
- Machine uncoupled from the tractor (vehicle) must be set in position and pin must be protected. When using slides and no support, position plough so that blades are folded to the rear.

2.1.3 HYDRAULIC SYSTEM

- The hydraulic system is under high pressure when operating.
- Regularly check the technical condition of the connections and the hydraulic conduits. There must be no oil leaks.
- In the event of malfunction of the hydraulic system, the machine shall be disconnected from use until the malfunction is corrected.
- When connecting the hydraulic conduits to the tractor (vehicle), make sure that the tractor (vehicle) hydraulic system and plough are not pressurised. If necessary reduce residual pressure in the system.

- In the event of injuries being caused by pressurised hydraulic oil, contact a doctor immediately. Hydraulic oil may find its way under the skin and cause infections. In the event of contact of oil with eye, rinse with large quantity of water and in the event of the occurrence of irritation consult a doctor. In the event of contact of oil with skin wash the area of contact with water and soap. Do NOT apply organic solvents (petrol, kerosene).
- Use the hydraulic oil recommended by the Manufacturer. Never mix two types of oil.
- Used oil or oil, which has lost its properties, should be stored in original containers or replacement containers resistant to action of hydrocarbons. Replacement containers must be clearly marked and appropriately stored.
- Do not store hydraulic oil in packaging designed for storing food or foodstuffs.
- Rubber hydraulic conduits must be replaced every 4 years regardless of their technical condition.
- Repair and replacement of hydraulic system elements should be entrusted to the appropriately qualified persons.

2.1.4 TRANSPORTING THE MACHINE

- When driving on public roads, comply with the road traffic regulations. in force in the country, in which the machine is used.
- Do not exceed the permitted speed arising from limitations of road conditions and construction limitations. Adjust travel speed to the prevailing road conditions and other limitations arising from road traffic regulations limits.
- Do NOT leave machine raised and unsecured while the tractor is parked. When parked, the machine should be lowered.
- Do NOT ride on the machine or transport any materials on it.
- Before using the machine always check its technical condition, especially in terms of safety. In particular, check the technical condition of the hitch system and elements connecting hydraulic system.
- During transport tractor three-point linkage or loader arm shall be locked in the up position to prevent accidental lowering.

- Reckless driving and excessive speed may cause accidents.

2.1.5 MAINTENANCE

- During the warranty period, any repairs may only be carried out by Warranty Service authorised by the manufacturer. It is recommended that necessary repairs to machine should be undertaken by specialised workshops.
- In the event of any fault or damage whatsoever, do not use the machine until the fault has been corrected.
- During work use the proper, close-fitting protective clothing, gloves and appropriate tools. When working on hydraulic systems it is recommended to use oil resistant gloves and protective goggles.
- Any modification to the machine frees PRONAR from any responsibility for damage or detriment to health which may arise as a result.
- Before undertaking any work on the machine, disconnect tractor (carrying vehicle) engine.
- Regularly check the technical condition of the safety devices and correct tightening of bolt connections.
- Regularly perform service inspections of machine as recommended by the Manufacturer.
- Do NOT perform service or repair work under raised and unsupported machine.
- Before beginning work on hydraulic systems, reduce oil pressure.
- Servicing and repair work should be carried out in line with the general principles of workplace health and safety. In the event of injury, the wound must be immediately cleaned and disinfected. In the event of more serious injuries, seek a doctor's advice.
- Repair, maintenance and cleaning work should be carried out with the tractor (carrying vehicle) engine switched off and the ignition key removed. Immobilise tractor with parking brake. Ensure that unauthorised persons do not have access to the vehicle.

- Should it be necessary to change individual parts, use only original parts. Non-adherence to these requirements may put the user and other people's health and life at risk, and also damage the machine and invalidate the guarantee.
- Regularly check technical condition and mounting of all guards and protective elements.
- The paint coating should be cleaned off before beginning welding work. Burning paint fumes are poisonous for people and animals. Welding work should be carried out in a well lit and well ventilated space.
- During welding work pay attention to flammable or fusible elements (parts of the hydraulic systems, plastic parts). If there is a risk that they will catch fire or be damaged, they should be removed or covered with non-flammable material before commencing welding work. Before beginning work prepare a CO₂ or foam extinguisher.
- In the event of work requiring the machine to be raised, use properly certified hydraulic or mechanical lifts for this purpose. After lifting the machine, stable and durable supports must also be used. Do NOT carry out work under a machine, which has only been raised with the three point linkage or extension arm.
- The machine must not be supported using fragile elements (bricks or concrete blocks).
- After completing work associated with lubrication, remove excess oil or grease.
- In order to reduce the danger of fire the machine must be kept in a clean condition.

2.1.6 PLOUGH OPERATION

- Before lowering or lifting the machine mounted tractor (carrying vehicle), make sure there are no bystanders, especially children, near the machine.
- Before starting the machine make sure that there are no bystanders (especially children) or animals in the danger zone. The machine operator is obliged to ensure proper visibility of the machine and the working area.
- During machine operation do not occupy a different position than that of the operator in the vehicle's cab. Do NOT leave the cab, when the machine is in operation.

- Do NOT stand within the machine's working zone and also between the tractor and the machine.
- Do NOT operate the plough while reversing. Lift machine when reversing.

2.2 DESCRIPTION OF MINIMAL RISK

Pronar Sp. z o. o. in Narew has made every effort to eliminate the risk of accidents. There is, however, a certain minimal risk, which could lead to an accident, and this is connected mainly with the actions described below:

- using the mower for purposes other than those for which it is intended,
- being between the tractor and the machine while the engine is working and when the machine is being attached,
- being on the machine while the engine is working,
- operating the machine with removed or faulty safety guards,
- not maintaining safe distance from the danger zone or being within the zones while the machine is operating,
- operation of the machine by persons under the influence of alcohol,
- cleaning, maintenance and technical checks when tractor is connected and engine is running.

The minimal risk may be kept to a minimum by following the recommendations below:

- prudent and unhurried operation of the machine,
- sensible application of the remarks and recommendations contained in the Operator's Manual,
- carrying out repair and maintenance work in line with operating safety rules,
- carrying out repair and maintenance work by persons trained to do so,
- using close fitting protective clothing,
- ensuring unauthorised persons have no access to the machine, especially children,
- maintaining safe distance from forbidden or dangerous places





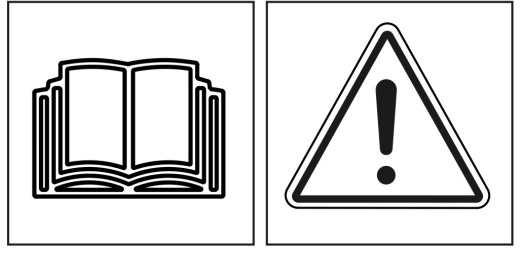
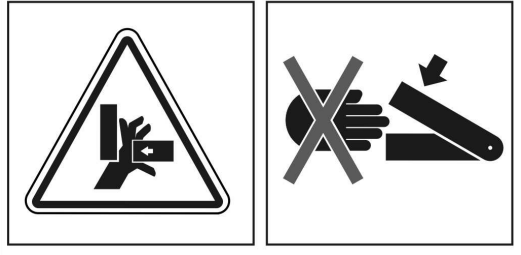
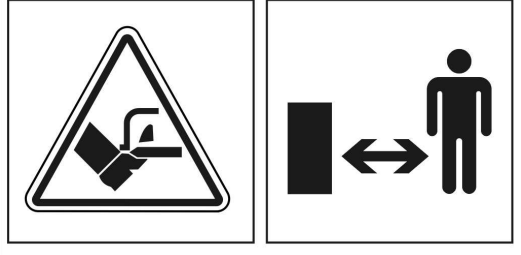
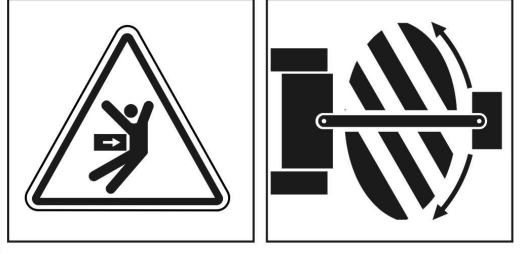

- a ban on being on the machine when it is operating

2.3 INFORMATION AND WARNING DECALS

All signs should always be legible and clean, visible to the operator and also to persons possibly being in the vicinity of working machine. If any safety sign is lost or illegible, it should be replaced with a new one. All elements having safety signs replaced during repairs should be affixed with these signs. Safety signs and decals may be purchased from the Manufacturer or the Seller.

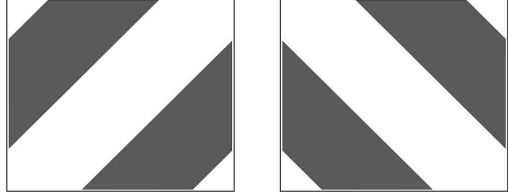
TABLE 2.1 Information and warning decals

ITEM	SYMBOL	DESCRIPTION
1		<p>Before starting work, carefully read the Operator's Manual.</p>
2		<p>Do not reach into crushing space because elements may move. Danger of crushing hands or fingers.</p>
3		<p>Keep a safe distance from machine when engine is running. Risk of injury to foot or leg.</p>
4		<p>When implement is in use the must be no bystanders in designated areas. If any work is required in these areas, make sure the tractor is stationary, and whether the implement is disconnected from the power source.</p>

ITEM	SYMBOL	DESCRIPTION
5		<p>Thrown out objects, endanger the whole body. Keep a safe distance from the operating machine.</p>
6		<p>Pressurised liquid. Keep a safe distance.</p>
7		<p>Outline marking.</p>
8		<p>Machine name</p>
9		<p>Machine model</p>
10		<p>Transport suspension points</p>

Numbers in the item column correspond to decals (FIGURE 2.1)



FIGURE 2.1 Locations of information and warning decals.

Meaning of symbols (TABLE 2.1)

SECTION

3

**DESIGN AND
OPERATION**

3.1 TECHNICAL SPECIFICATION

TABLE 3.1 BASIC TECHNICAL SPECIFICATION

Plough model		PU-1700	PU-2100
	Unit		
Mounting method: - three point linkage	-	cat. I-II ISO 730-1 (fixed or swing suspension)	
- front loader	-	cat. I „narrow” ISO 730-1 (fixed)	
- other	-	EURO mount, ŁC-1650 (swing suspension) EURO-SMS (swing rotary suspension) mounting plate (swing suspension) for individual installation	
Width depending on the operating position (FIGURE 3.1):			
A	mm	1,930	2,210
B	mm	1,680	1,920
C	mm	1,870	2,100
D	mm	1,870	2,100
Working height of plough blade	mm	900 ± 20	
Number of working positions	item	4	
Operation	-	hydraulic using solenoid	
Number of hydraulic cylinders	item	2	
Power supply	-	External hydraulic system and the tractor (vehicle) electrical system 12V	
Type of collecting strips	-	swing, rubber or metal	
Weight of machine ready for operation:			
- with front three-point linkage (fixed) cat. I-II ISO 730-1	kg	250	265
- with front three-point linkage (swing suspension) cat. I-II ISO 730-1	kg	280	293
- with EURO-SMS system,	kg	282	296
- with mounting for loaders	kg	292	306
- with mounting plate	kg	316	330
Weight of additional equipment:			
- slides (2 pcs.)	kg	34	
- pivot pins (2 pcs)	kg	13	
Power demand	hp	25 ÷ 55	
Maximum working speed	km/h	10	
Other information	-	Single person operation	

Level of noise emitted by machine does not exceed 70 dB(A)

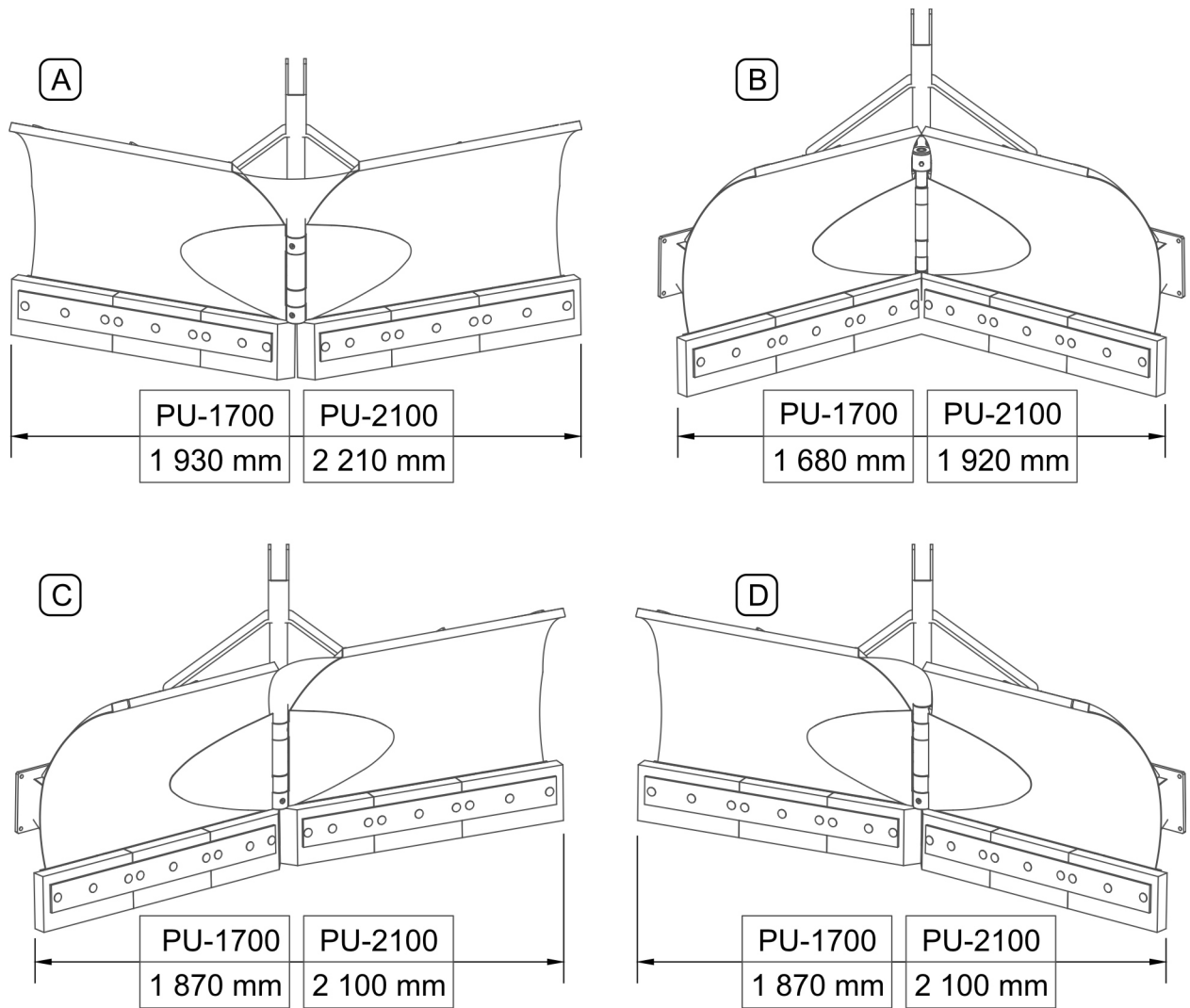

FIGURE 3.1 Width depending on the operating position:

3.2 GENERAL DESIGN

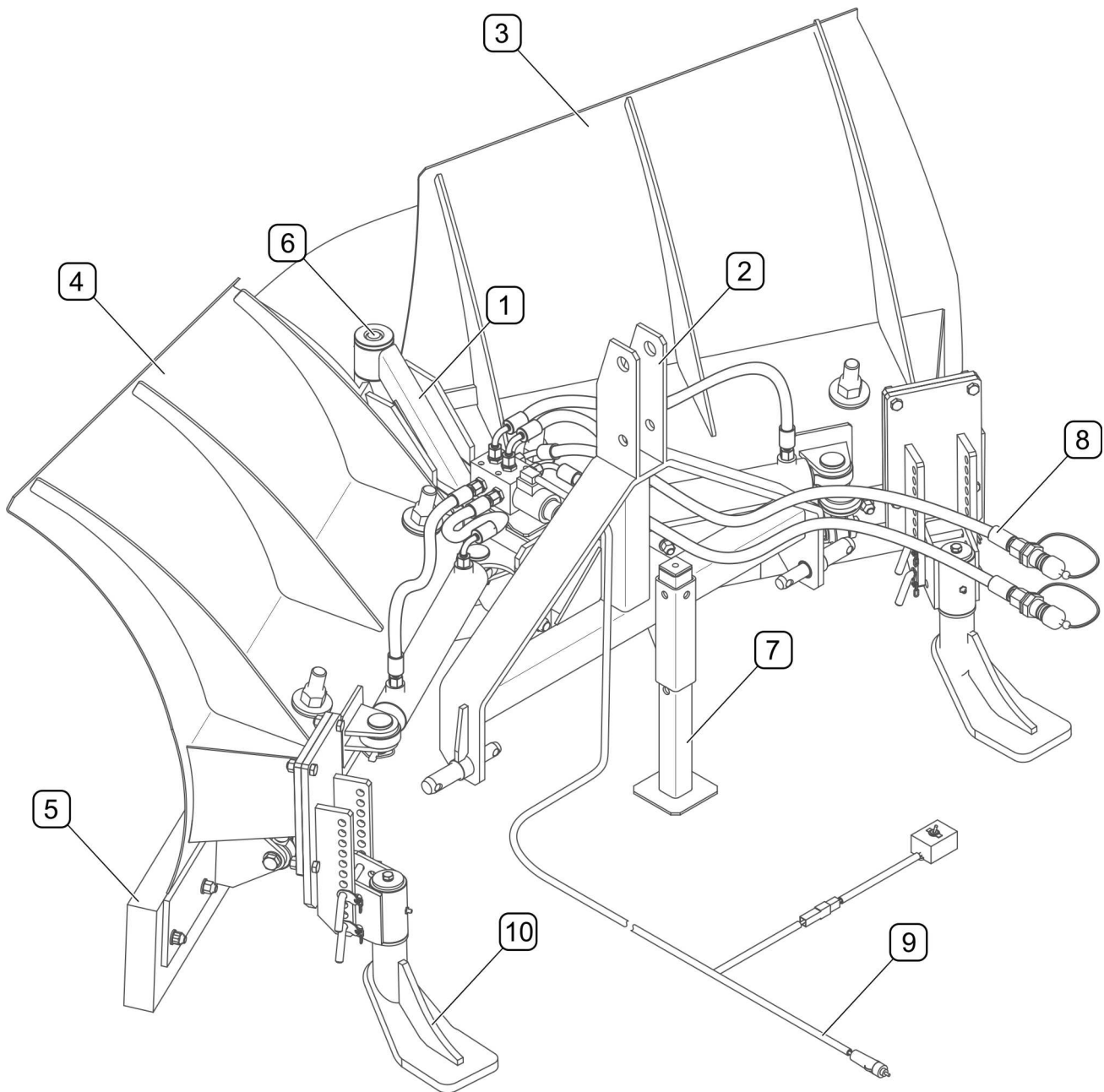

FIGURE 3.2 General design

(1) - frame, (2) - linkage, (3) - right blade, (4) - left blade, (5) - swing collecting strips; (6) - main pin, (7) - parking support; (8) - hydraulic system (9) - electrical system, (10) - slides (optional)

PU-1700/PU-2100 plough consists of a frame (1) to which through the main pivot(6) right (3) and left (4) blades are connected. Using a suitable suspension system (2) plough is linked to a tractor or front loader. Collecting strips (5) with shock absorbing springs are able to swing backwards when an obstacle is encountered. Parking support (7) is used to support the

plough when it is disconnected from the carrying vehicle. The PU-1700/PU-2100 plough can also be equipped with slides (10) and other linkage systems allowing linking with front loader or the LC-1650 or EURO-mount, swing three-point linkage system (FIGURE 4.1)

3.3 HYDRAULIC SYSTEM

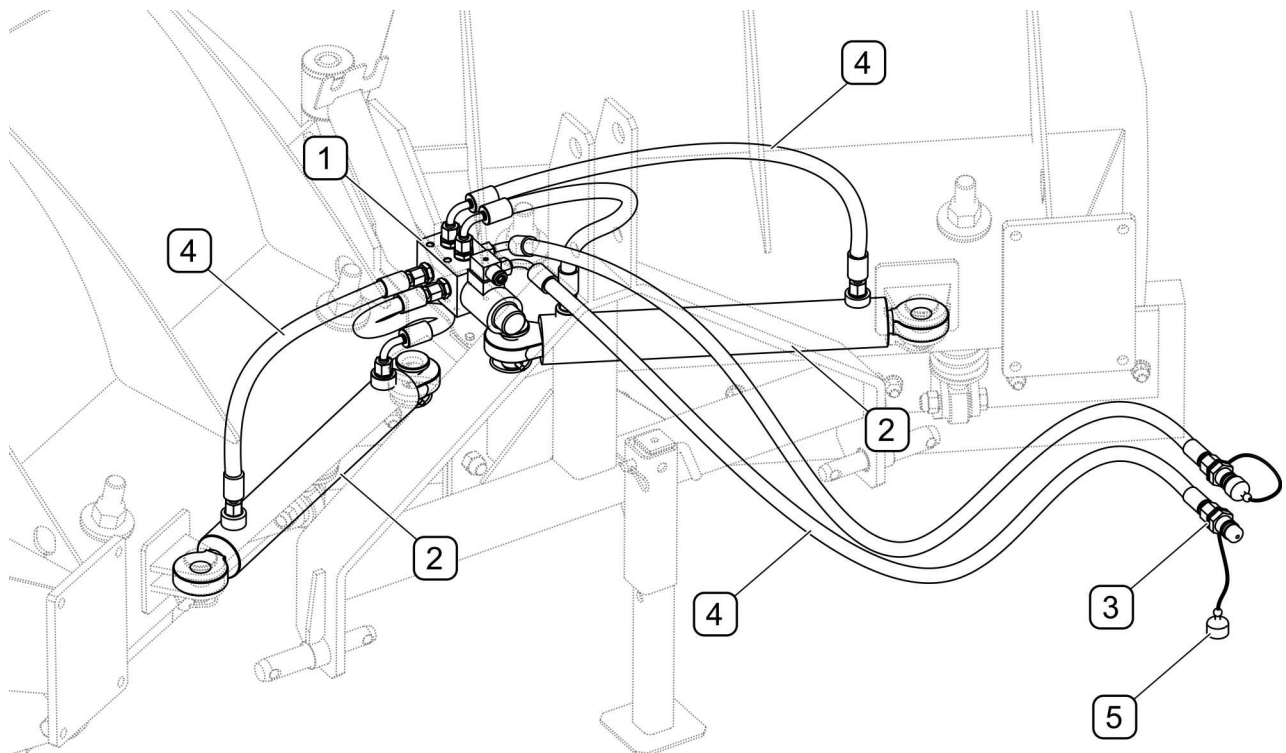

FIGURE 3.3 Hydraulic system design

(1) - solenoid, (2) - hydraulic cylinders, (3) - quick coupler plug, (4) - hydraulic conduits, (5) - plug stopper

Plough blades working position can be adjusted by means of two hydraulic cylinders (2) controlled by solenoid valve (1) using the electrical switch in the operator cab. Plough hydraulic system is powered with oil supplied from the tractor or loader by two conduits terminated with quick couplings.

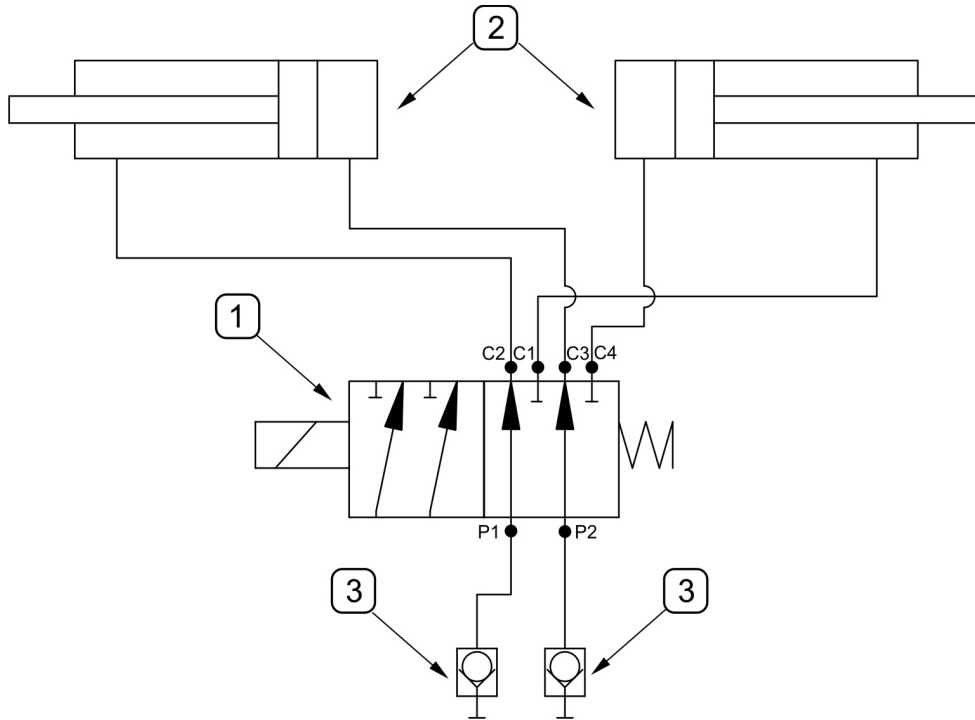

FIGURE 3.4 Hydraulic system concept diagram

(1) - solenoid valve, (2) - hydraulic cylinders, (3) - quick coupling plug,;

3.4 ELECTRICAL SYSTEM

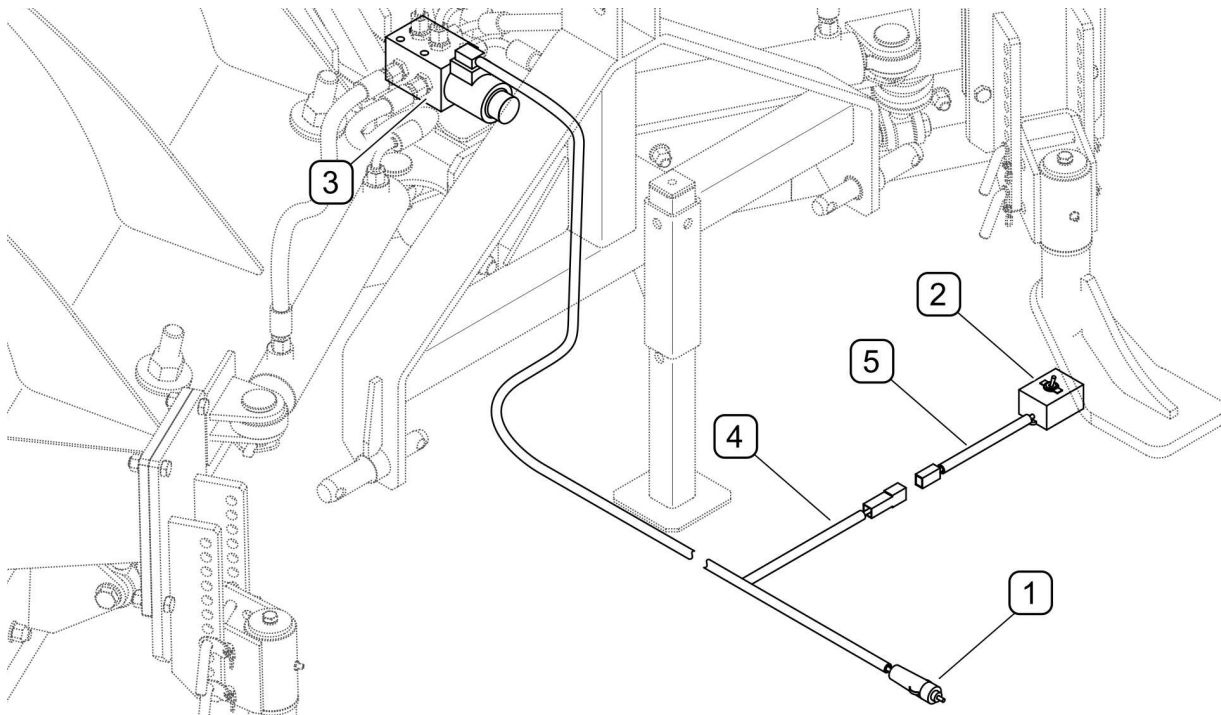

FIGURE 3.5 Electrical system components

(1) - cigarette lighter socket, (2) - switch, (3) - solenoid valve, (4) - solenoid valve cable strand, (5) - switch cable strand

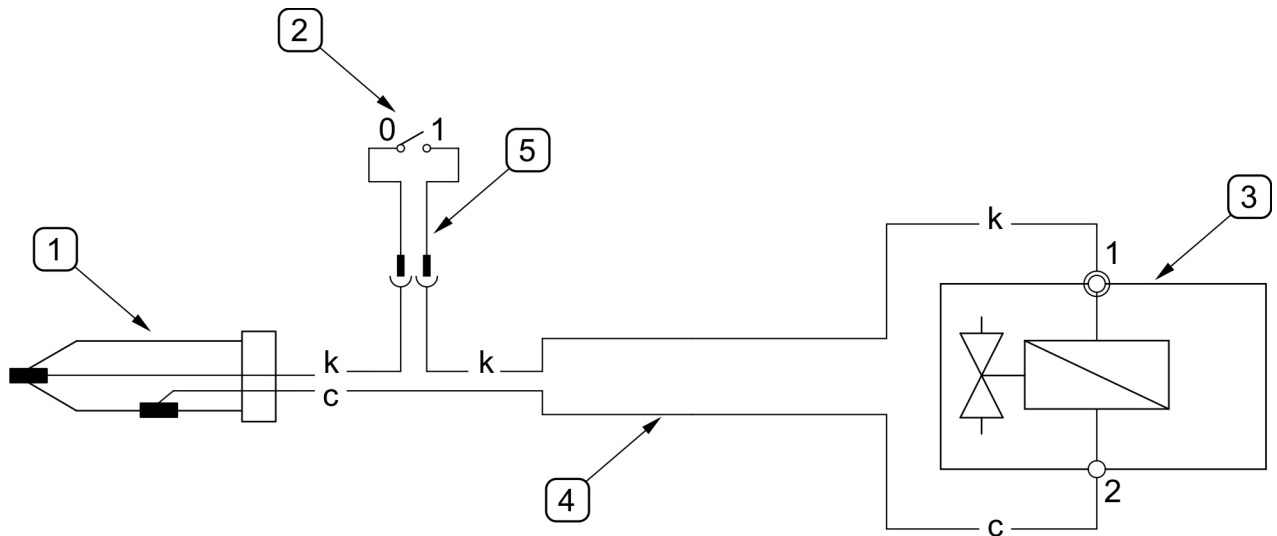

FIGURE 3.6 Electrical system diagram

(1) - cigarette lighter socket, (2) - switch, (3) - solenoid valve, (4) - solenoid valve cable strand, (5) - switch cable strand; c - black; k - red

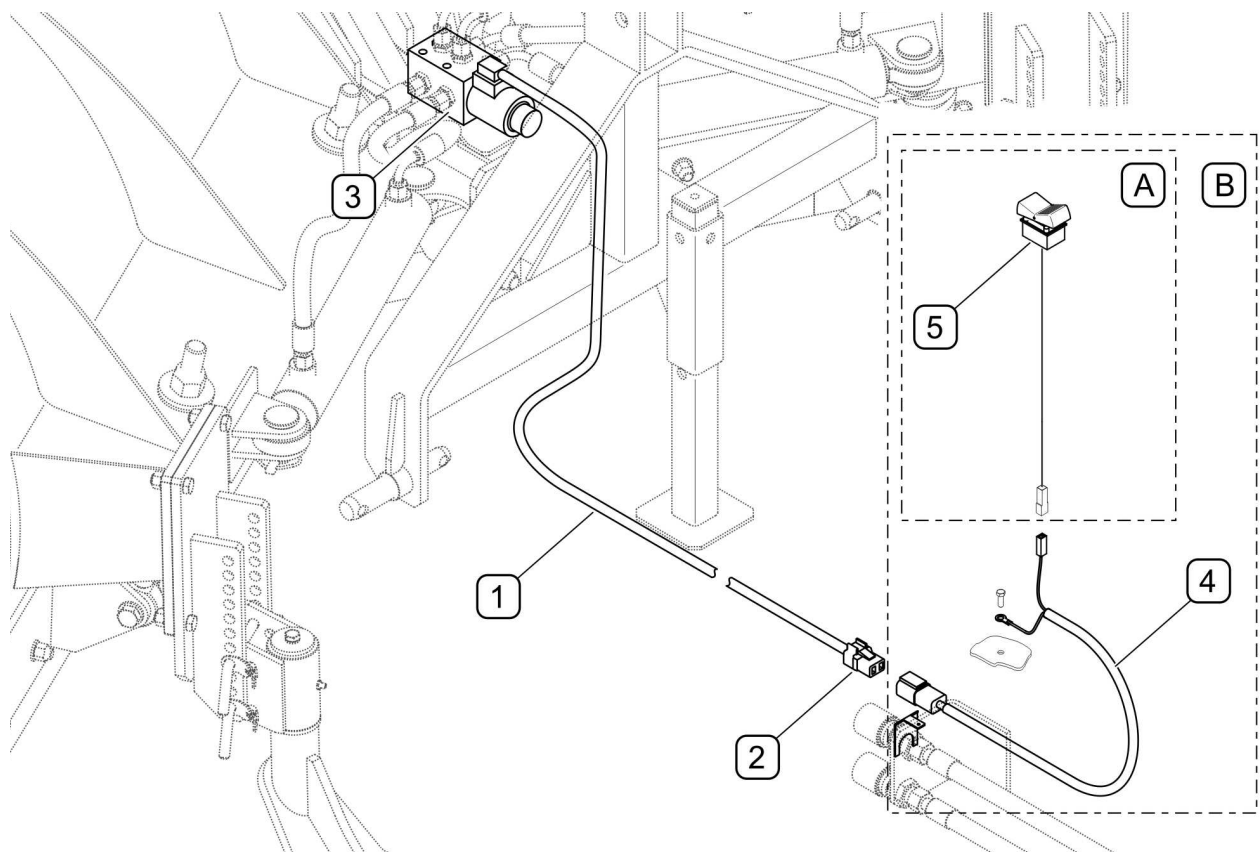

FIGURE 3.7 Electrical system components (320A/AM/AMK)

(1) - solenoid valve power cable, (2) - 2-pin plug, (3) - solenoid valve, (4) - cable with 2-pin socket, (5) - key switch in the tractor; (A) - Pronar 320A/AM tractor electrical system (B) - Pronar 320AK/AMK tractor electrical system (municipal version)

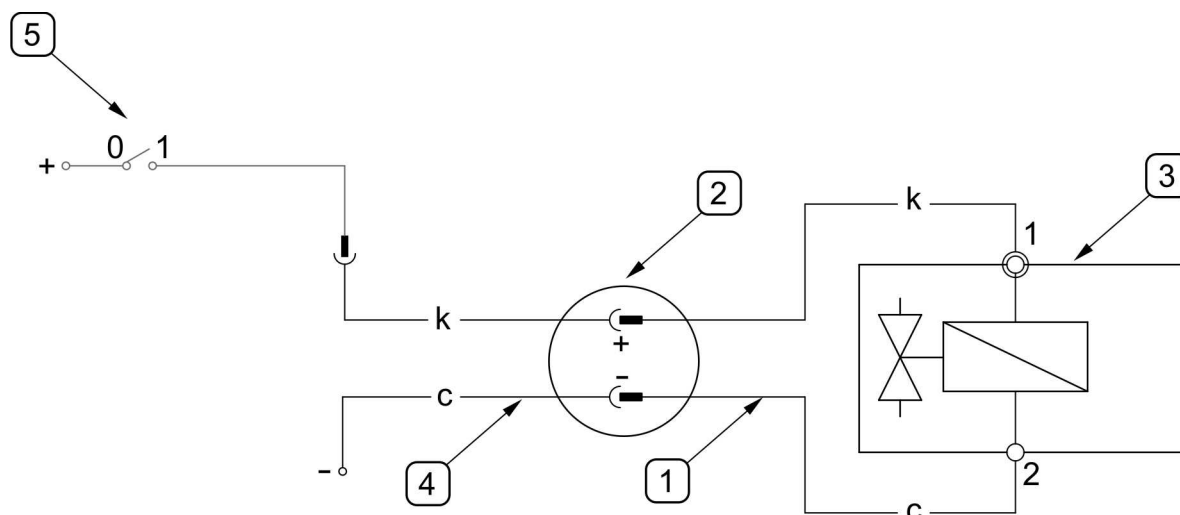

FIGURE 3.8 Schematic diagram of the electrical system (Pronar 320A/AM/AMK)

(1) - solenoid power cord, (2) - 2-pin plug, (3) - solenoid valve; (4) - cable with 2-pin socket,
 (5) - Key switch in the tractor; black c - black; k - red

SECTION

4

**CORRECT
USE**

4.1 PREPARING FOR WORK

DANGER



Before using the plough, the user must carefully read this operator's manual.

Careless and improper use and operation of the machine, and non-compliance with the recommendations given in this operator's manual is dangerous to your health.

The machine must never be used by persons, who are not authorised to drive agricultural tractors (carrying vehicles), including children and people under the influence of alcohol or other drugs.

Non-compliance with the safety rules of this Operator's Manual can be dangerous to the health and life of the operator and others.

Before starting the machine, make sure that there are no bystanders in the danger zone.

The manufacturer guarantees that the machine is fully operational and has been checked according to quality control procedures and is ready for normal use. This does not release the user from an obligation to check the machine's condition after delivery and before first use. The machine is delivered to the user completely assembled (except for individually packed wiring).

Prior to connecting to the tractor, machine operator must verify the machine's technical condition. In order to do this:

- the user must carefully read this Operator's Manual and observe all recommendations, understand the design and the principle of machine operation
- check the compatibility of the plough linkage with suspension system of the carrying vehicle,
- make sure that electrical wiring and hydraulic system outlets are compatible,
- check the condition of protective paint coat,
- Inspect machine's individual components for mechanical damage resulting from incorrect transport (dents, piercing, bent or broken components),
- check all the lubrication points, lubricate the machine as needed according to recommendations provided in section 5 "MAINTENANCE",
- check technical condition of the hydraulic and electrical system;
- check the technical condition of the collecting strips,

- check the technical condition of the linkage components,

**ATTENTION!**

Non-adherence to the recommendations contained in the Operator's Manual or improper use may cause damage to the machine.

The technical condition before starting the machine must be a cause for concern.

If all the above checks have been performed and there is no doubt as to the machine's good technical condition, it can be connected to carrying vehicle, started and all its individual systems checked. In order to do this:

- Hitch the machine to a tractor or other carrying vehicle (see "*HITCHING TO CARRYING VEHICLE*")
- After connection of hydraulic system conduits and electrical system wiring, the correct operation of individual systems should be checked with inspection of systems and hydraulic cylinders with regard to seals and tightness.
- check your plough settings for each working position,

In the event of a disruption in the operation of the machine immediately discontinue its use, locate and remove the fault. If a fault cannot be rectified or the repair could void the guarantee, please contact the Manufacturer for additional clarifications.

**ATTENTION!**

Before using the machine always check its technical condition. In particular, check the technical condition of the hitch and hydraulic system.

4.2 CHECKING TECHNICAL CONDITION

When preparing the machine for normal use, check individual elements according to guidelines presented in table (4.1)

TABLE 4.1 TECHNICAL INSPECTION SCHEDULE

DESCRIPTION	SERVICE OPERATION	FREQUENCY
Technical condition of blades and collecting strips.	Visually inspect and if necessary replace according to section " <i>REPLACEMENT OF COLLECTING STRIPS</i> "	before beginning work
Technical condition of slides (option)	check the technical condition, if complete and correctly mounted.	
Technical condition of linkage	check the technical condition, if complete and correctly mounted.	
Technical condition of the hydraulic system.	Visually inspect the technical condition	
Technical condition of the electrical controls	Visually inspect the technical condition	
Check of all main nut and bolt connections are properly tightened	Torque values should be according to table (5.5)	Once a week
Lubrication	Lubricate elements according to table „ <i>LUBRICATION</i> ".	According to table (5.3)



ATTENTION!

The machine must not be used when not in working order.

4.3 HITCHING TO CARRYING VEHICLE

The PU-1700/2100 plough may only be mounted on a tractor (carrying vehicle) fulfilling the requirements contained in table 1.1 "AGRICULTURAL TRACTOR (CARRYING VEHICLE) REQUIREMENTS".



ATTENTION!

Before hitching the plough to tractor (carrying vehicle), the user must carefully read the tractor (carrying vehicle) operator's manual.



DANGER

When hitching, there must be nobody between the machine and the tractor (carrying vehicle). A person assisting in the hitching of the machine should stand in such a place (beyond the area of danger), in order to be continuously visible to the tractor driver.

Exercise caution when hitching the machine to carrying vehicle.



ATTENTION!

Plough equipped with a "rigid" hitching system A, C, D (FIGURE 4.1) should be mounted only to the carrying vehicle equipped with a floating section control.

Tractor weight (carrying vehicle) must not be transferred to the plough, as it could result in damaging it.

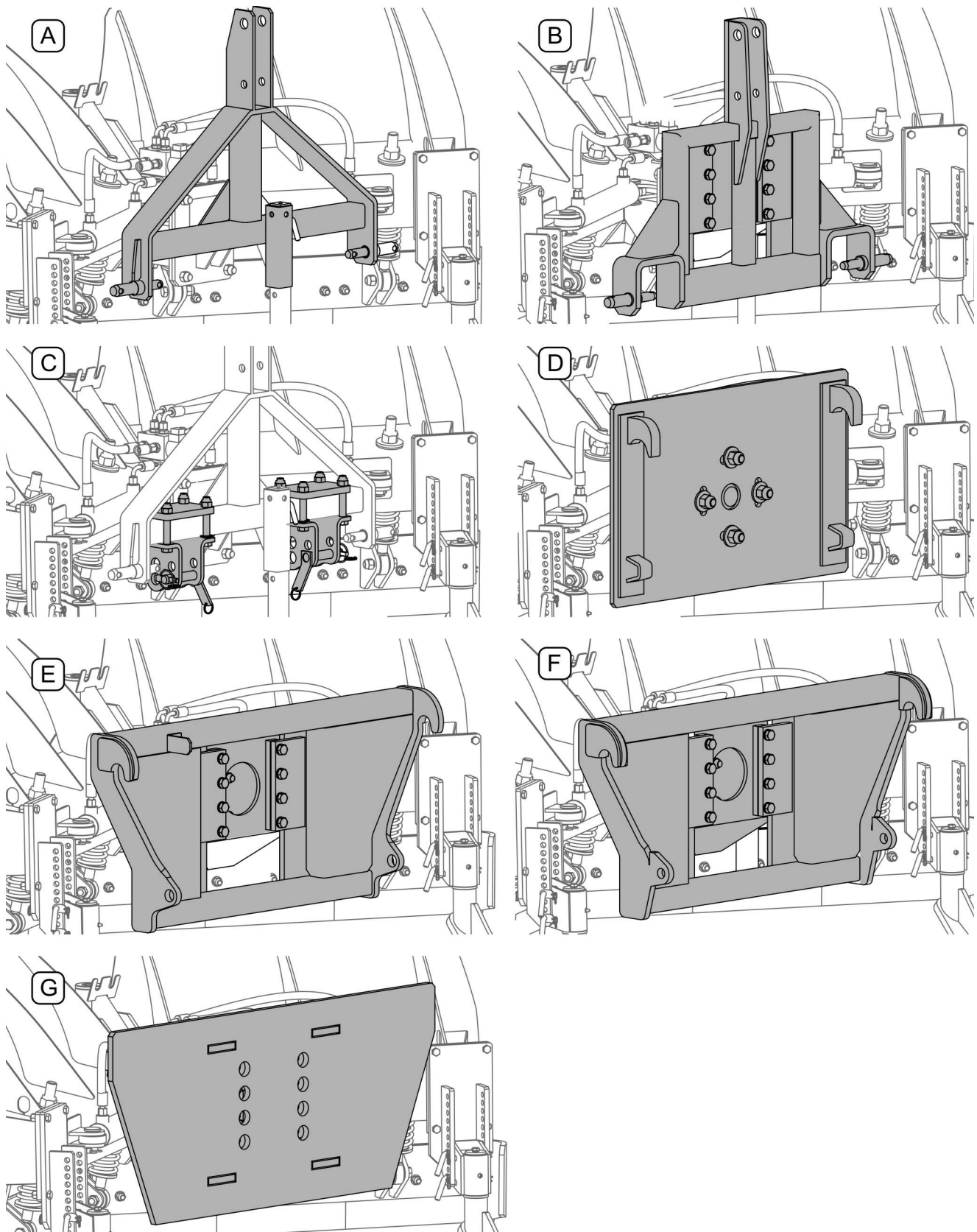

FIGURE 4.1 Types of linkage systems

(A) - three-point linkage cat. I-II (rigid); (B) - three-point linkage cat. I-II (swinging); (C) - pivot pins cat. I-II mounted on rigid three-point linkage; (D) - EURO-SMS linkage (swing rotary suspension); (E) - for ŁC-1650 loader (swinging); (F) - for loaders with EURO linkage

(swinging); (G) - mounting plate (swing) for individual installation, without mounting components

4.3.1 HITCHING TO THE THREE POINT LINKAGE

Before hitching the plough to tractor three-point linkage, make sure that the category of the tractor linkage is compatible with that of the plough.

Hitching the plough to tractor three-point linkage do the following:

- move the lower rod of tractor three-point linkage to the lower linking points of the plough. Set lower rods at an appropriate height,
- switch off tractor's engine and prevent it from moving,
- connect the lower pins of the plough linkage with three-point linkage and secure with linchpins,
- in the case of the hook linkage place balls on plough linkage pins and lift the pins until balls lock in hooks,
- connect tractor upper link (central connector) to the plough upper attachment point and secure with linchpin,
- in tractors equipped with lower linkage with tensioner, lateral plough movements must be eliminated by appropriate adjustment of the tensioners; it is recommended that both the lower links of the three-point linkage are set at the same height,
- Lift plough using tractor's three point linkage.
- Raise parking stand and secure with linchpin.



DANGER

To mount machine on tractor (carrying vehicle) use only genuine pins and safeguard linchpins.

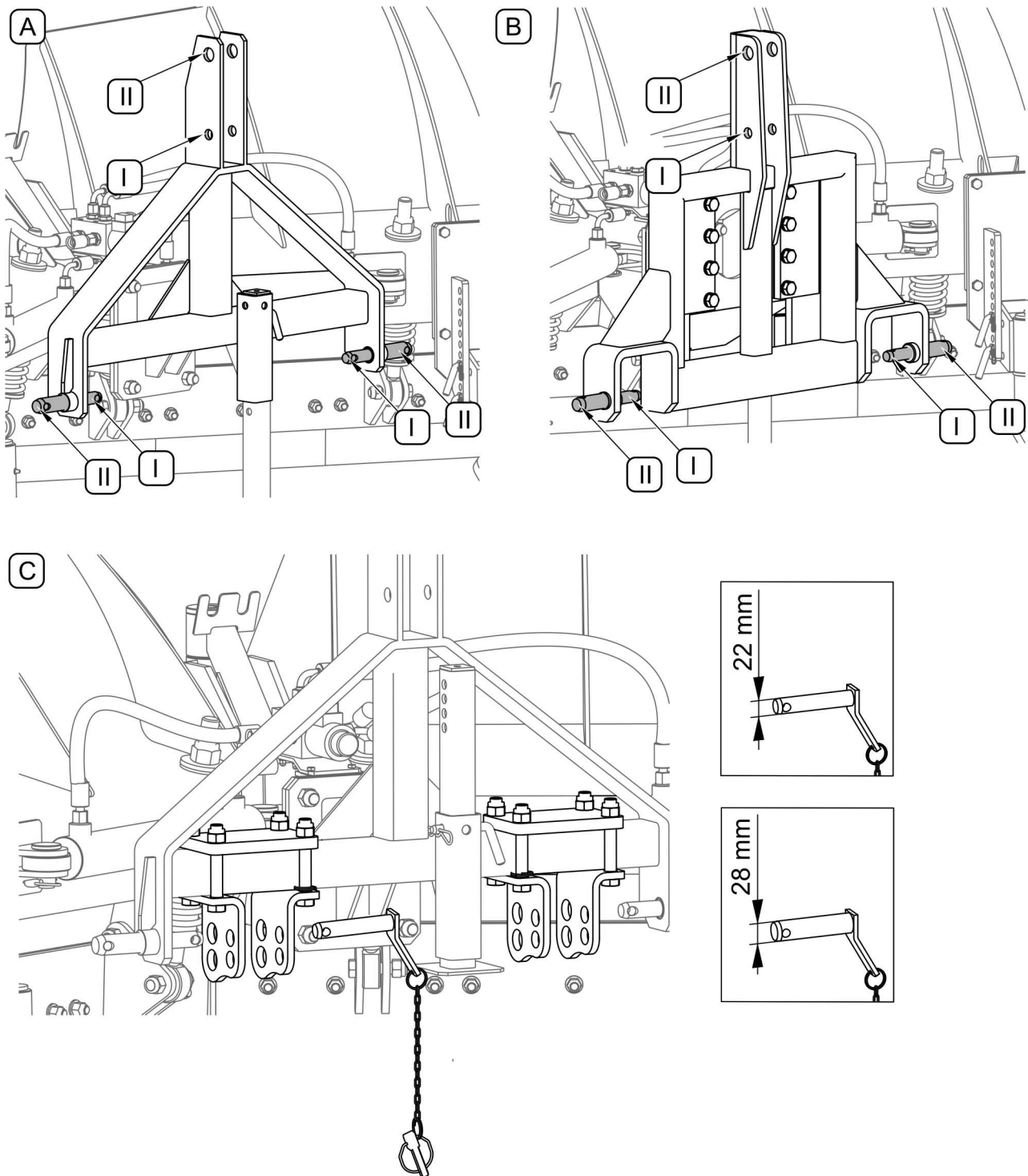

FIGURE 4.2 Three-point linkage categories according to ISO 730-1

(A) - rigid three-point linkage cat. I-II; (B) - swinging three-point linkage cat. I-II; (C) - pivot pins cat. I narrow, mounted on rigid three-point linkage; (I) - mounting points cat. I according to ISO 730; (II) - mounting points cat. II according to ISO 730-1

If the tractor three-point linkage does not allow the required spacing of lower links for category I-II according to ISO 730-1 (FIGURE 4.2) linkage system (A) can be equipped with

pivot pins (C), which allow narrower spacing of the lower linking points. For the pivot pins (C), pins suitable for the hole in the tractor three-point linkage links should be used.

4.3.2 HITCHING TO FRONT LOADER

In order to hitch plough to front loader (FIGURE 4.3):

- unlock quick securing mechanism in loader frame;
- lower arm and turn frame downwards (A) so that mounting points on quick mounting frame are below the mounting points of the plough;
- drive loader close to the plough and insert mounting points in the appropriate places in the quick mounting frame;
- lift the arm (B) so that the upper mounting points are in the plough hooks;
- controlling the loader frame tilt it back (C), causing the locking of the quick mounting mechanism;
- check if mounting is secure;
- engage the quick securing mechanism (depending on loader type)
- raise the parking stand (FIGURE 4.4)

The described method of connecting is indicative and may vary depending on the loader model. A detailed method of connecting attachments is provided in front loader operator's manual.

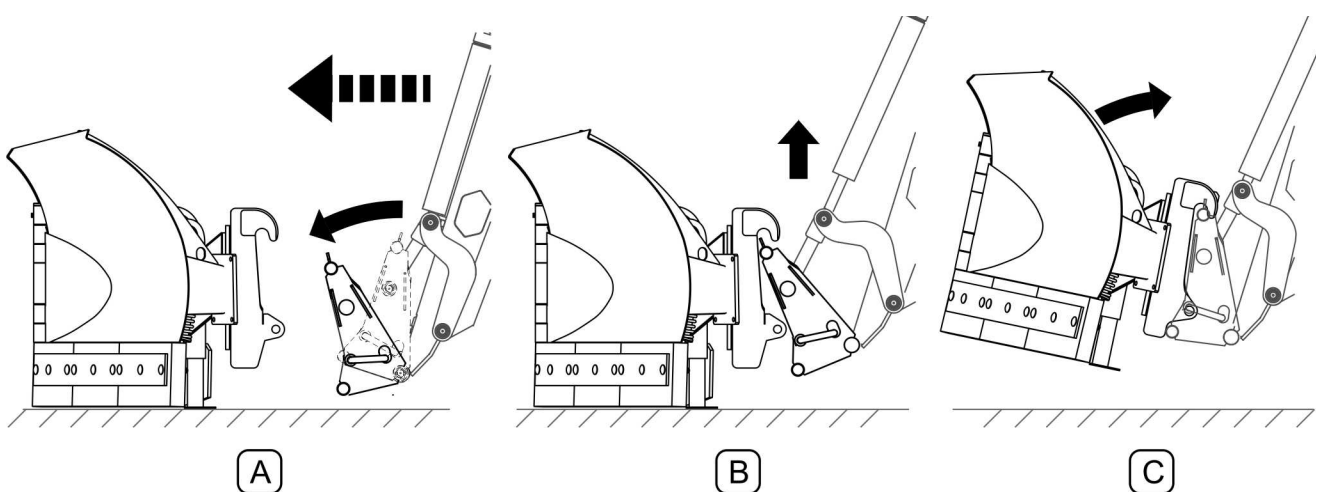

FIGURE 4.3 Hitting to front loader

(A), (B),(C)- next stages of connecting



IMPORTANT!

It is not recommended to operate a snowplough attached to front loader with a speed of more than 6 km/h.

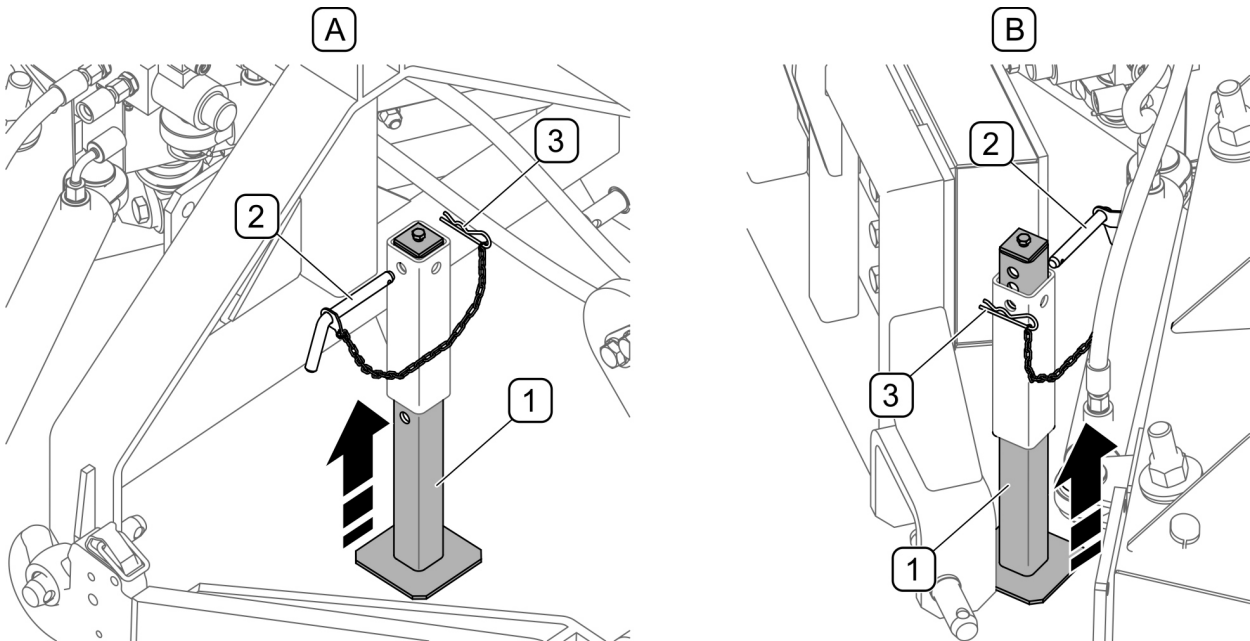

FIGURE 4.4 Parking stand

(A) - ploughs with a rigid linkage system, (B) - plough with the swing suspension system;
(1) - support; (2) - pin; (3) - locking linchpin

During the operation, after mounting the plough on the carrying vehicle insert parking stand (1) in the guide upwards (FIGURE 4.4) and secure its position using a pin (2) and secure with spring linchpin (3) - does not apply to ploughs with the EURO-SMS linkage.

4.4 CONNECTING HYDRAULIC AND ELECTRICAL SYSTEM

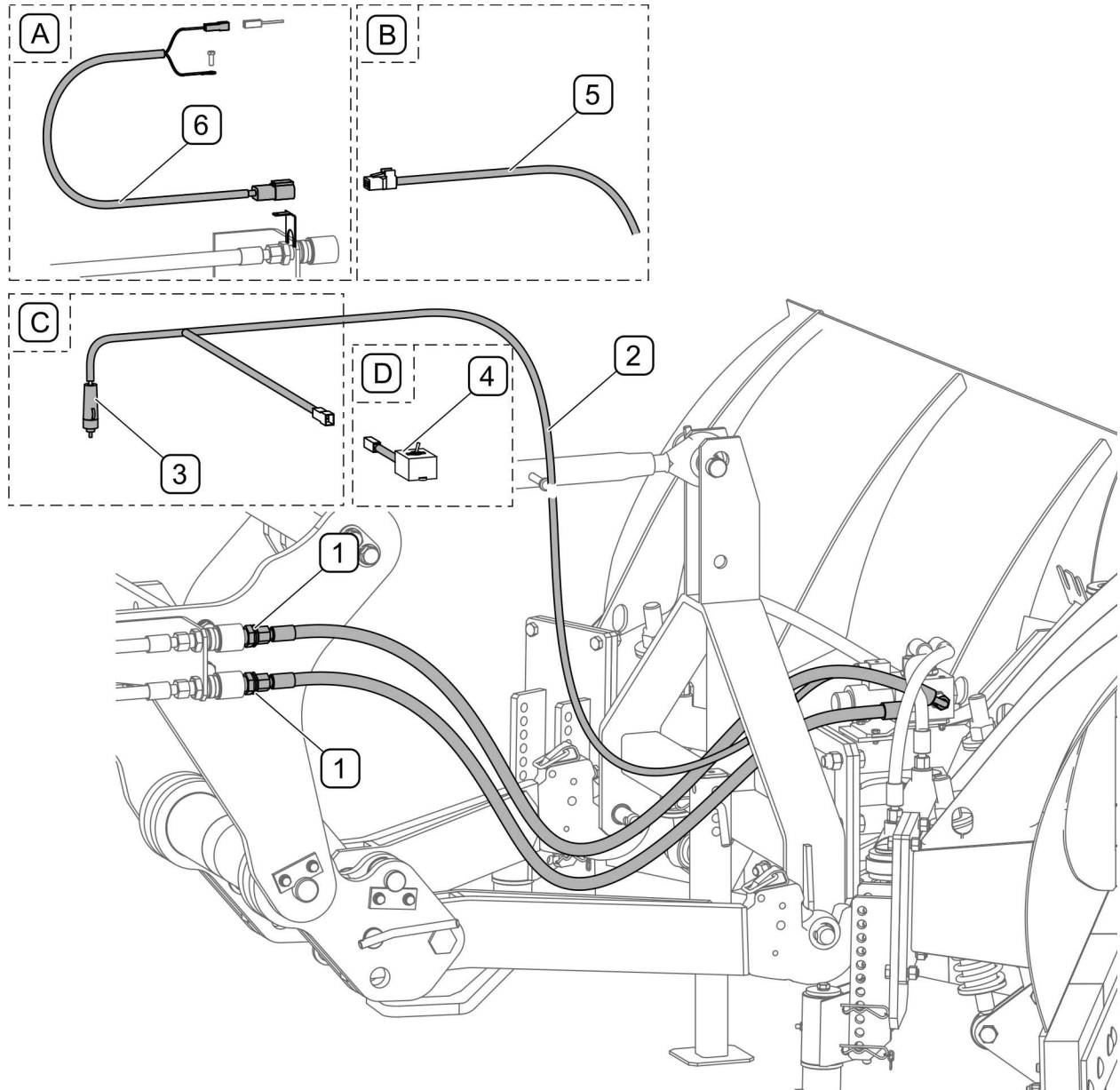

FIGURE 4.5 Connecting hydraulic and electrical system to tractor

(A) - Utility connection mounted on the tractor (Pronar 320A/AK/AM/AMK); (B) - solenoid control connection mounted on the plough (Pronar 320A/AK/AM/AMK), (C) - solenoid wiring strand, (D) - switch wiring strand; (1) - hydraulic connectors, (2) - solenoid power cord, (3) - cigarette lighter socket, (4) - switch, (5) - solenoid power cord (Pronar 320A/AM/AMK); (6) - cable with a 2-pin socket (for 320A/AM tractors, pre-installed in municipal version tractors)



DANGER

Prior to connecting individual system conduits the user must carefully read the tractor operator's manual and observe all Manufacturer's recommendations.

Connect plough control hydraulic conduit connectors (1) to the tractor external hydraulic outlets (FIGURE 4.5). When connecting hydraulic conduits to the tractor make sure they are arranged without bends and twists, and are protected from damage.

Plug(3) of solenoid (2) power cord is connected to 12V cigarette lighter socket, connect switch (4) to lead (2) place in the operator cab in an accessible place. Arrange electrical wires so as to prevent their damage during operation.

In Pronar 320A/320AM tractors, connect lead (6) to tractor electrical system. Mount 2-pin socket in the front of the tractor using bracket. Connect solenoid power cord (5) to 2-pin socket.

Pronar 320AK/320AMK tractors (municipal version) are factory-equipped with cable (6) terminated with 2-pin socket and do not require installation of additional electrical components.



DANGER

When connecting the hydraulic conduits to the tractor, make sure that the tractor hydraulic system is not under pressure.



ATTENTION!

During operation, the connecting cables should be routed so that they do not get entangled in moving machine parts.

TABLE 4.2 PLOUGH CONTROL ELECTRICAL ELEMENTS DEPENDING ON THE TRACTOR (CARRYING VEHICLE)

MARKING (FIGURE 4.5)	NAME/ CATALOGUE NO.	APPLICATION		
		Tractor Pronar 320A/320AM	Tractor Pronar 320AK/320AMK	Other (carrying vehicles)
A	Municipal Connection 17RPN-04.00.02 Connection bracket 6RPN-06.06.02	•	—	—
B	Control Connection 17RPN-04.00.01	•	•	—
C	Solenoid wiring strand 126RPN-09.01.00.00	—	—	•
D	Switch wiring strand 126RPN-09.02.00.00	—	—	•

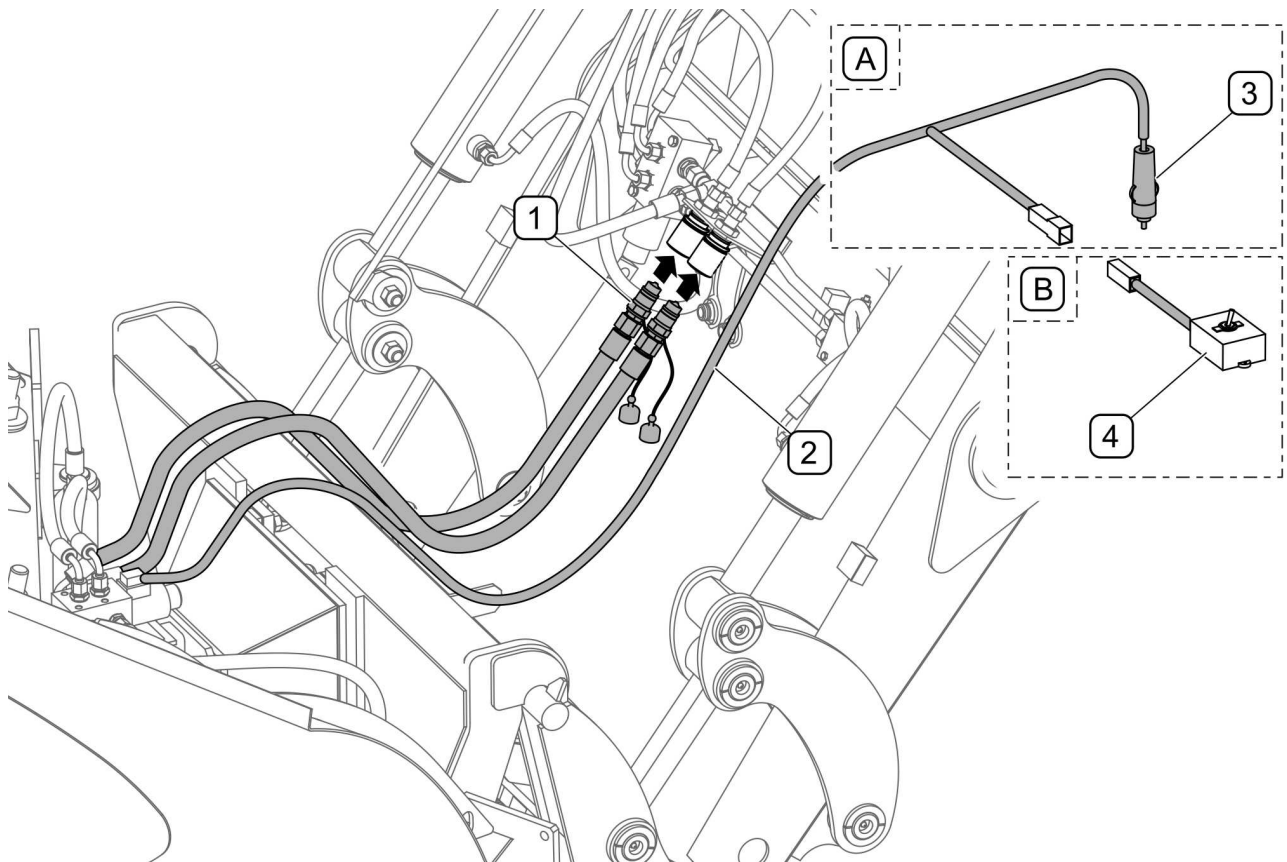

FIGURE 4.6 Connecting hydraulic and electrical system to loader

(A) - solenoid valve wiring strand (B) - switch wiring strand; (1) - hydraulic connectors, (2) - solenoid valve power cable, (3) - cigarette lighter socket, (4) - switch;

Connect plough control hydraulic conduit connectors (1) to the loader external hydraulic outlets. Plug(3) of solenoid (2) power cord is connected to 12V cigarette lighter socket, connect switch (4) to lead (2) place in the operator cab in an accessible place. Arrange electrical wires and hydraulic conduits so as to prevent their damage during operation.

4.5 PLOUGH OPERATION

4.5.1 LEVELLING PLOUGH BODY

For optimum operation, plough body should level (the main blades pivot axis should be perpendicular to the ground and collecting strips vertical). In carrying vehicles with three-point linkage this is done by controlling the central link, while in front loaders by positioning a frame (eg, using implement position indicator, if any). Otherwise, collecting strips will wear unevenly.

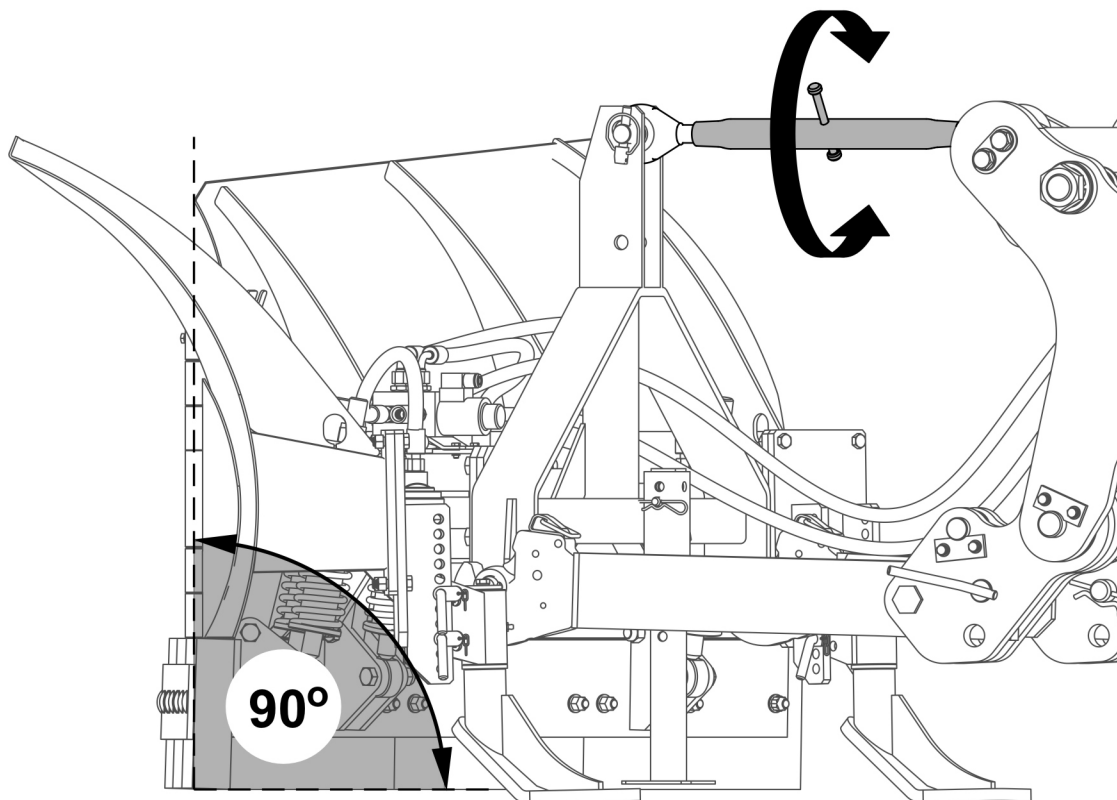

FIGURE 4.7 Levelling plough body

4.5.2 ADJUSTING PLOUGH WORKING POSITIONS

PU-1700/2100 plough has four adjustable working positions. To change the plough working position, use a single lever valve on the tractor and an electric switch.

When switch is set to "OFF" or "0" single plough blade can be controlled and when the switch is flipped to "ON" or "1" (the other plough blade can be controlled (FIGURE 4.8)

**DANGER**

The plough is controlled from the operator cab.
When plough is in use there must be no bystanders near the machine.

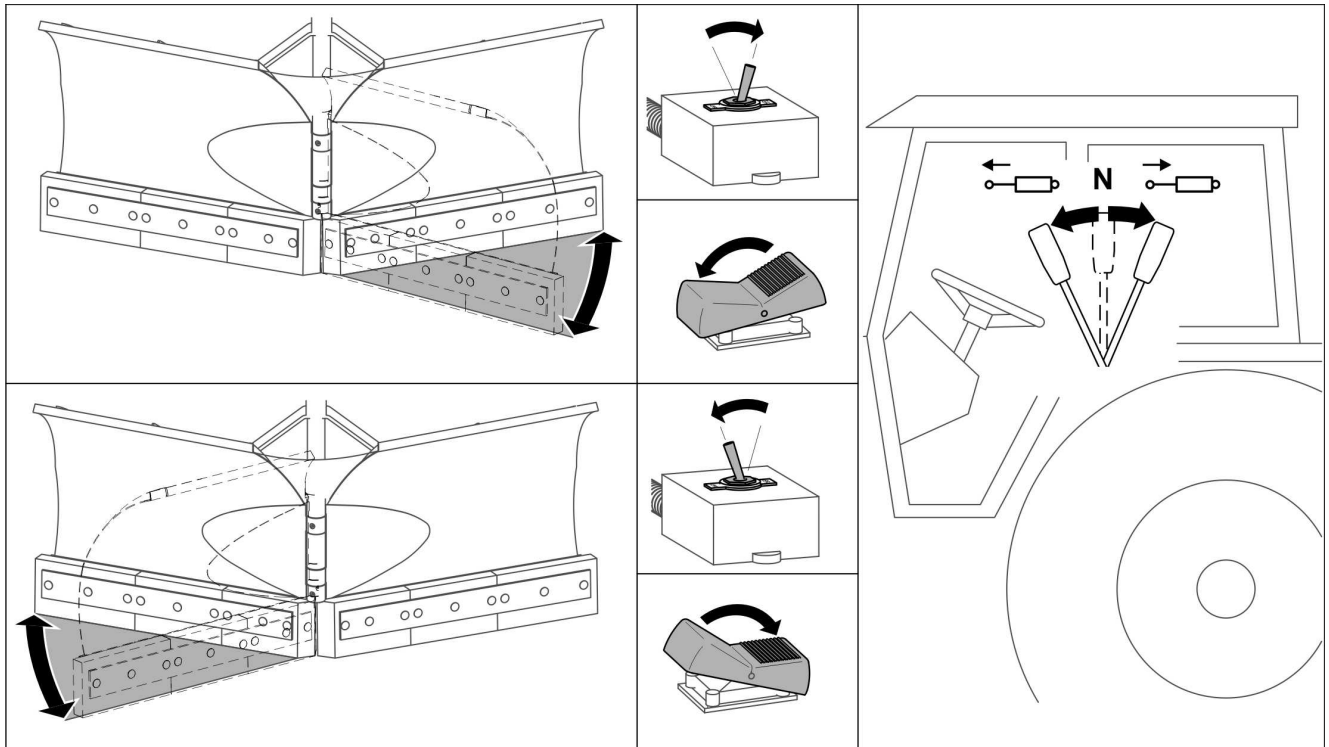

FIGURE 4.8 Setting working position

**IMPORTANT!**

It is not recommended to operate the machine in heavy duty condition with a speed of more than 6 km/h.

Working speed depends on the quantity and quality of collected material but also on the type of terrain. It is not recommended to operate PU-1700/2100 plough mounted on front loaders when blades are set (right or left) in severe conditions, ie:

- uneven terrain,
- unknown terrain and obstacles
- packed or frozen snow or ice,
- snow layer thicker than 30 cm.

4.5.3 SETTING COLLECTING STRIPS INCLINATION ANGLE



DANGER

Setting collecting strips inclination angle and height can be performed only when the engine is stopped, the machine is raised and secured.

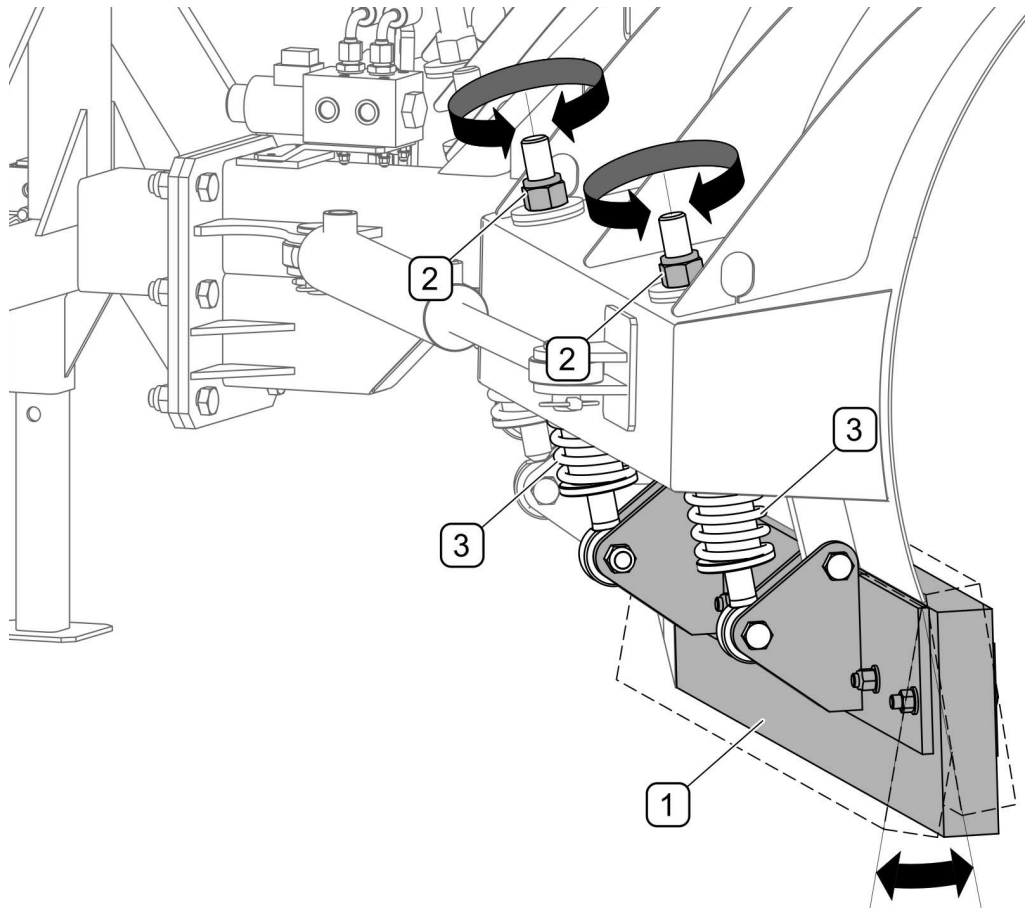

FIGURE 4.9 Setting collecting strips inclination angle

(1) - collecting strips, (2) - adjusting screw nut, (3) - shock absorbing strips

When collecting strips (1) encounter an obstacle they swing back thanks to cushioning springs (3). Adjust collecting strips angle by turning the nuts (2) or spring tensioning screws (3).

PU-1700 and PU-2100 ploughs are equipped with standard springs (3) catalogue number 17RPN-03.00.00.05. If a more rigid mechanism for tilting collecting strips is necessary, harder spring should be used, catalogue number 17RPN-03.00.00.05-01

4.5.4 SETTING WORKING HEIGHT

In PU-1700/2100 ploughs equipped with optional height-adjustable slides, work is done by unlocking pin and the ejection or withdrawal of the slide in the guide. Location of the slide in the guide can be changed every 10 mm. When the height is set, slides must be protected with a pin and linchpin. Slides of the left and right blade should be put forward at the same height. The recommended distance of the collecting strips from the swept area is 5 to 10 mm. Adjustment of the left and right slide is carried out in the same way.

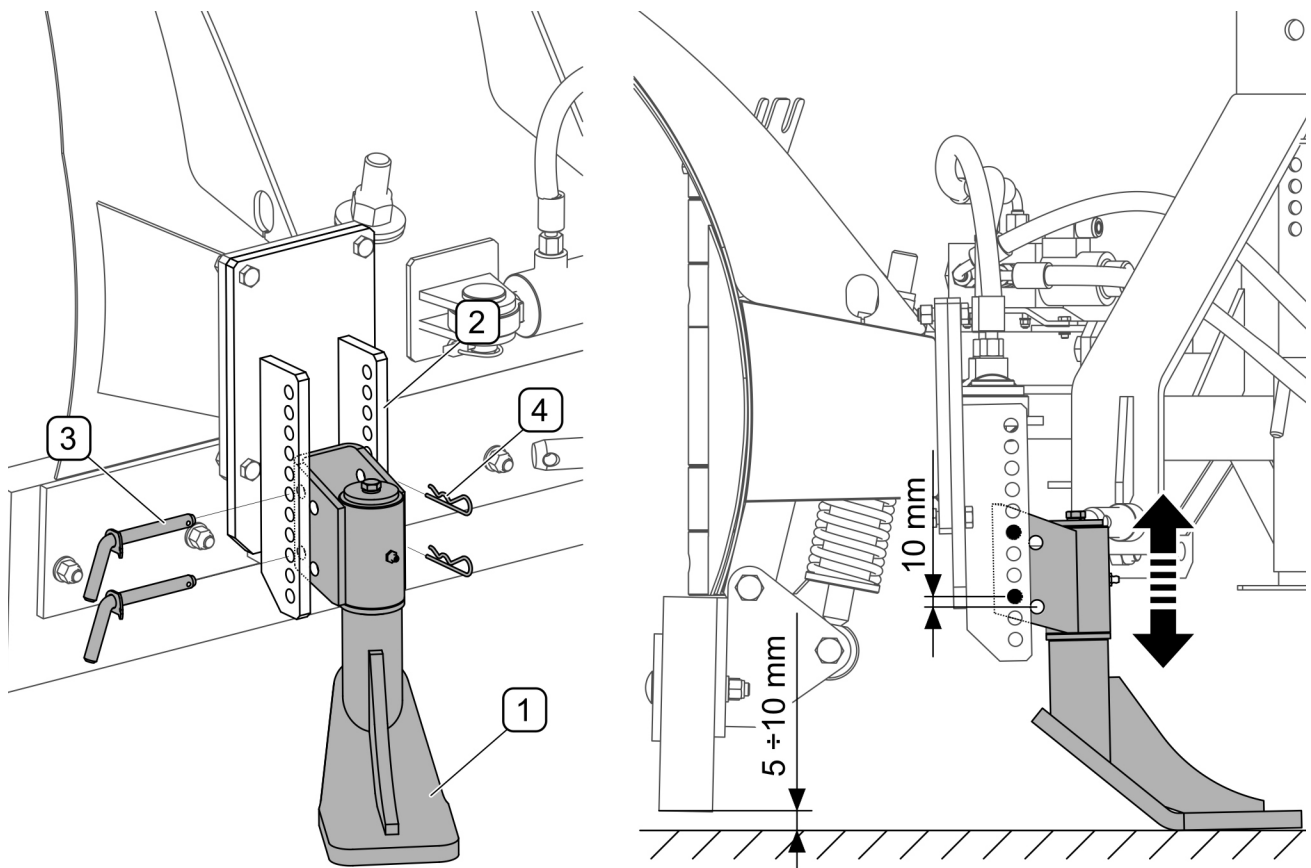

FIGURE 4.10 Height adjustment in ploughs equipped with slides

(1) - slide, (2) - slide guide (3) - pin, (4) - locking linchpin

4.6 DRIVING ON PUBLIC ROADS

When driving on public roads, respect the road traffic regulations, exercise caution and prudence. If the clearing with plough is done on a pavement special attention should be paid to the bystanders likely to be near the machine. Listed below are the key guidelines.

- Before moving off make sure that there are no bystanders, especially children, near the machine or the tractor. Take care that the driver has sufficient visibility.
- Make sure that the plough is correctly attached to the tractor (carrying vehicle), and linkage is properly secured.
- While driving or operating the machine on public roads turn on clearance lamps.
- Permissible design speed and maximum speed allowed by road traffic law must not be exceeded. Speed of travel should be adjusted to prevailing road conditions and other conditions.
- While working a plough turn the orange beacon light in tractor.
- Avoid ruts, depressions, ditches or driving on roadside slopes. Driving across such obstacles could cause the machine or the tractor to suddenly tilt. Driving near ditches or canals is dangerous as there is a risk of the wheels sliding down the slope or the slope collapsing.
- Speed must be sufficiently reduced before making a turn or driving on an uneven road or a slope.
- When driving on uneven terrain with the implement raised reduce speed due to dynamic loads and the risk of damaging the machine or carrying vehicle.
- When driving with raised plough set it so as not to obscure the lights or restrict the visibility of the operator.
- When driving with raised implement, secure the tractor (carrying vehicle) linkage against falling or accidental dropping.

4.7 DISCONNECTING THE PLOUGH

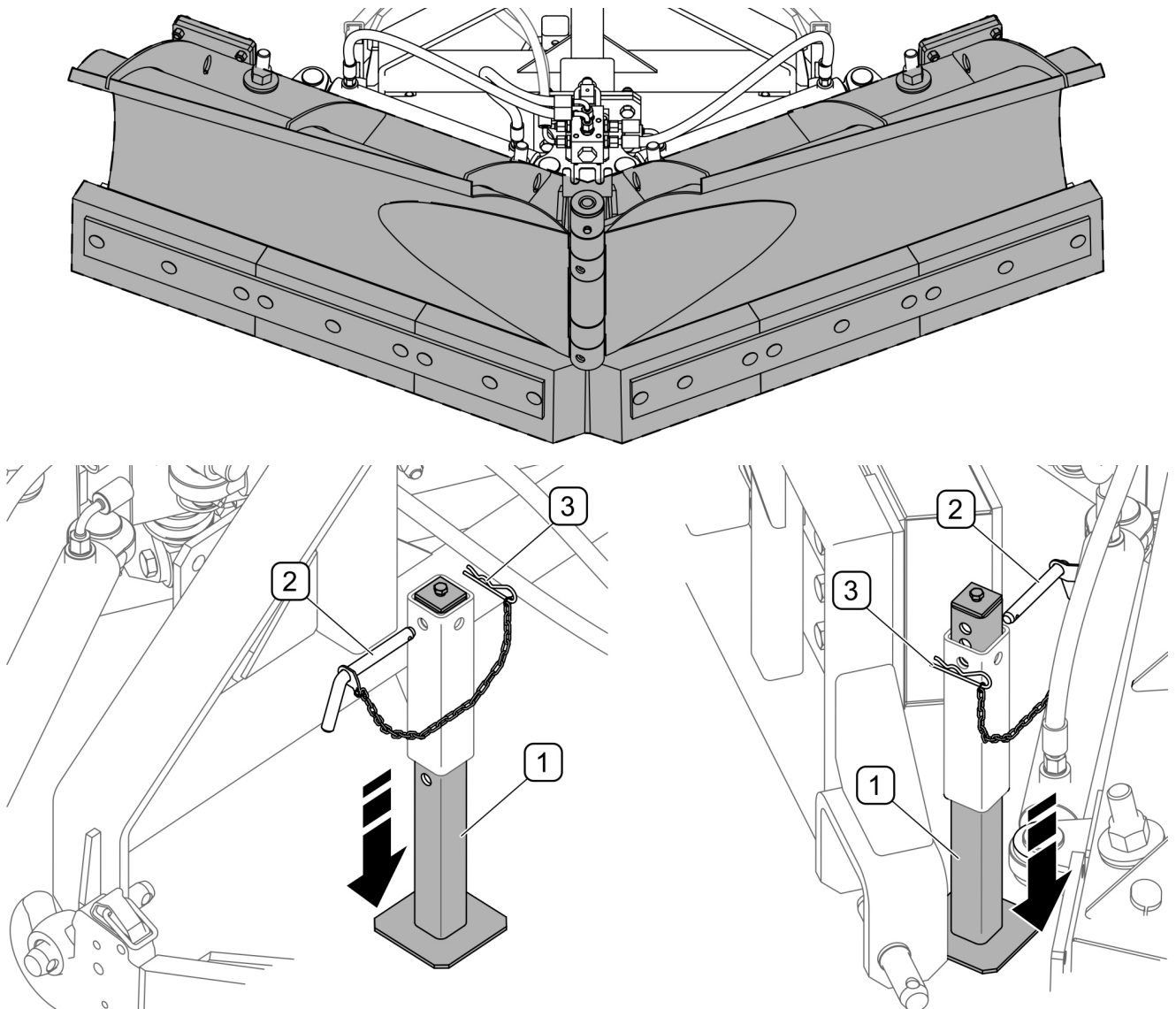

FIGURE 4.11 Disconnecting from tractor

(1) - parking stand; (2) - pin; (3) - linchpin;

In order to disconnect the plough from the tractor, proceed as follows:

- position plough so that blades are folded to the rear. (FIGURE 4.11)
- remove the linchpin (3) and pin (2), lower the stand (1) (if any), set at the correct height and lock,
- lower the plough until it fully rests on the ground,
- turn off the engine in the tractor, engage the parking brake,

- reduce residual pressure in the hydraulic system by movement of appropriate lever controlling hydraulic circuit,
- disconnect hydraulic conduit plugs from the tractor and electric power lead of the electromagnetic regulator
- protect hydraulic conduit quick couplings against soiling and put in proper places on a frame support (FIGURE 4.12).
- Disconnect the plough from the tractor (carrying vehicle) linkage.

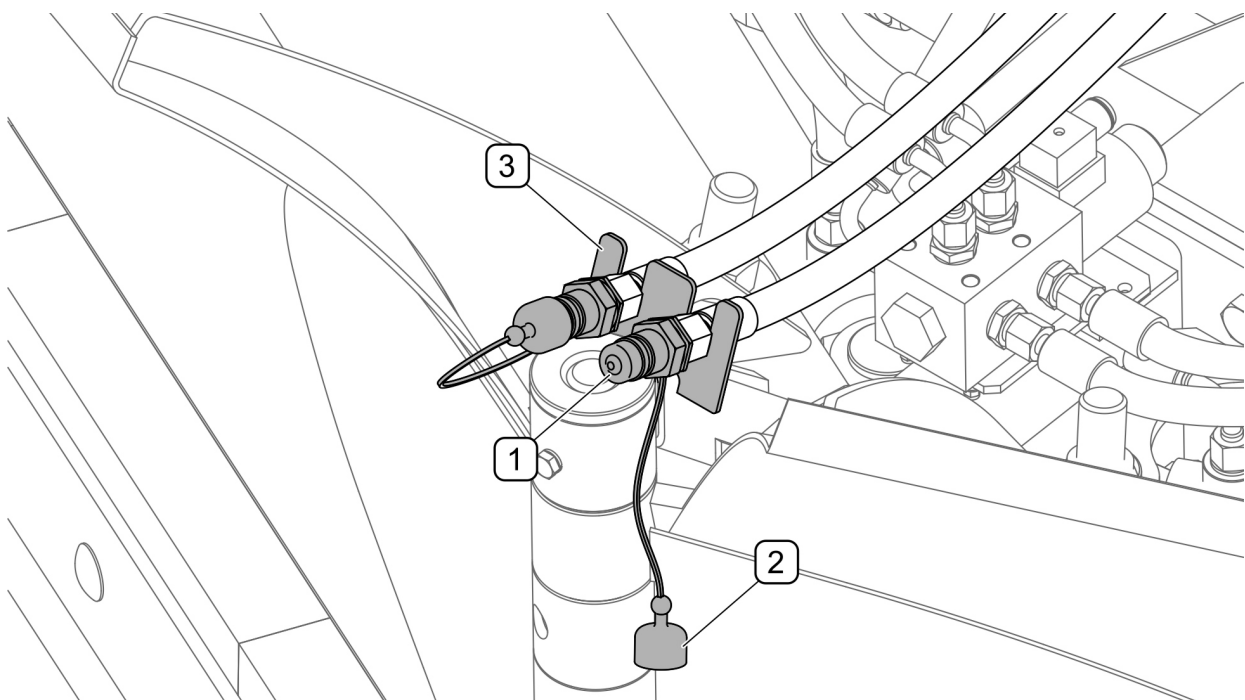

FIGURE 4.12 hydraulic sockets plug protection

(1) - hydraulic socket plugs; (2) - plug; (3) - plug mounting support



DANGER

Reduce pressure prior to disconnecting the hydraulic system.

SECTION

5

MAINTENANCE

5.1 CHECKING AND REPLACEMENT OF COLLECTING STRIPS



DANGER

During inspection and replacement of collecting strips, switch off tractor engine and remove the key from the ignition.

Excessively worn or damaged collecting strips must be replaced. Raise the plough and support with sufficiently stable and strong supports. If the plough is hitched and raised on the front three-point linkage, protect it from falling and immobilise the tractor (turn off the engine and engage the parking brake.)



DANGER

Do NOT perform service or repair work under raised and unsupported machine.

Rubber collecting strip consists of three segments (A,B,C) (FIGURE 5.1). To remove the segments of the strip, unscrew the nuts (3), remove screws (1) and remove the clamp strip (2). Replace the strip segments, reassemble in reverse order.

To remove the metal collecting strips (D) unscrew the nuts (3), remove screws (1) and remove the collecting strip. Install the new strip in reverse order. If the plough is equipped with slides (option) and collecting strips are replaced it is recommended that working height is checked and possibly adjusted (see 4.5.4 *SETTING WORKING HEIGHT*)

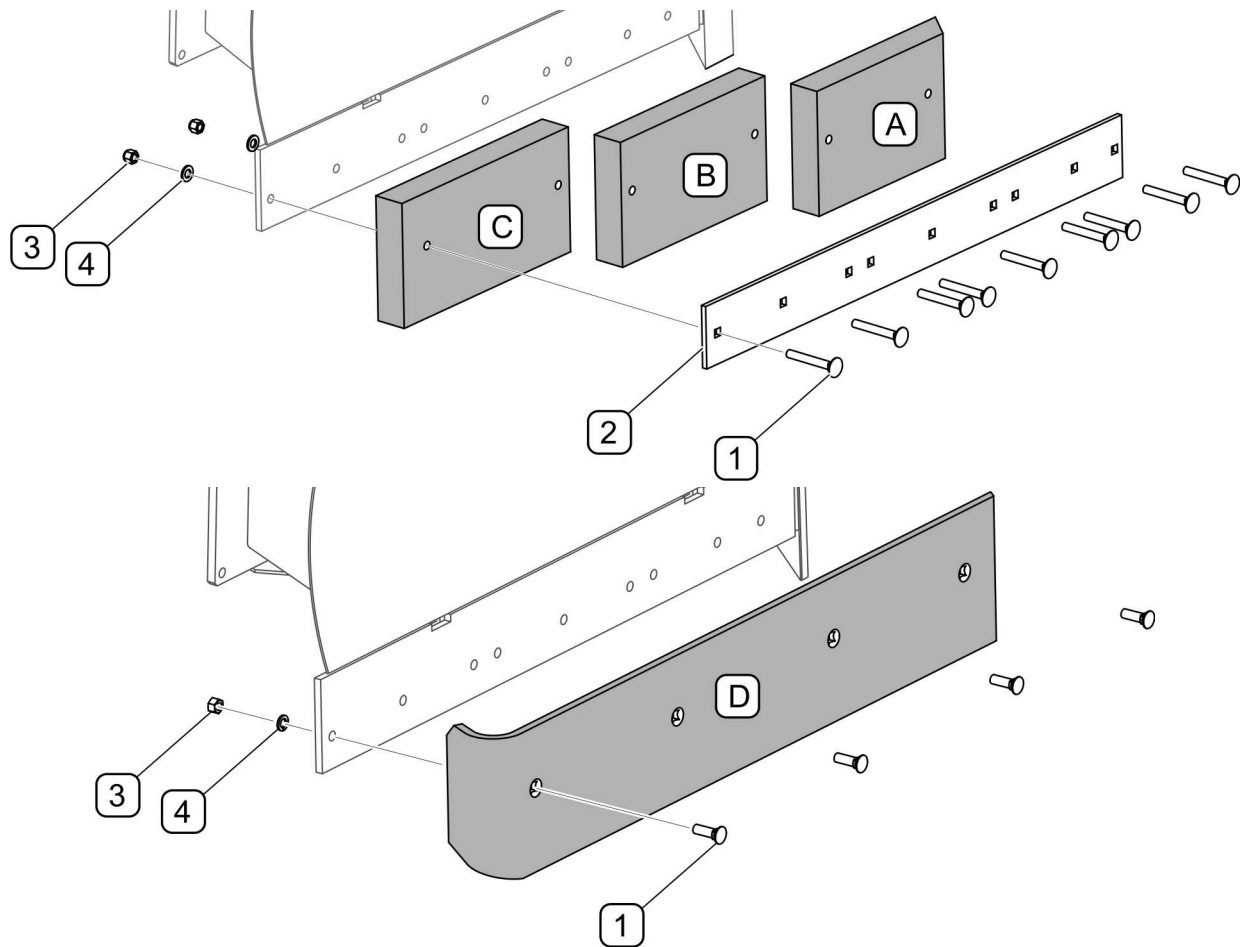

FIGURE 5.1 Replacing collecting strip

(A) - rubber I; (B) - rubber II; (C) - rubber III; (D) - metal collecting strip; (1) - screws;
(2) - clamping strip, (3) - nuts, (4) - washers;

TABLE 5.1 THE TYPES OF COLLECTING STRIPS IN PU-1700 PLOUGHS

Marking FIGURE 5.1	Name / Catalogue No.	Number of items	
		Blade right	Blade left
Rubber collecting strip			
A	Rubber I right / 17RPN-03.02.00.02P	1	—
	Rubber I left / 17RPN-03.02.00.02L	—	1
B	Rubber II / 17RPN-03.02.00.03	1	1
C	Rubber III / 17RPN-03.02.00.04	1	1
Metal collecting strip			
D	Collecting strip P / 17RPN-03.02.00.05P	1	—
	Collecting strip L / 17RPN-03.02.00.05L	—	1

TABLE 5.2 THE TYPES OF COLLECTING STRIPS IN PU-2100 PLOUGHS

Marking FIGURE 5.1	Name / Catalogue No.	Number of items	
		Blade right	Blade left
Rubber collecting strip			
A	Rubber I right / 17RPN-03.02.00.02P	1	–
	Rubber I left / 17RPN-03.02.00.02L	–	1
B	Rubber II / 17RPN-03.02.00.03	1	1
C	Rubber III / 17RPN-07.02.00.04	1	1
Metal collecting strip			
D	Collecting strip P / 17RPN-07.02.00.05P	1	–
	Collecting strip L / 17RPN-07.02.00.05L	–	1

	<p>ATTENTION!</p> <p>Each time snowplough hits an obstacle technical condition of collecting strips and their mounting should be carried out.</p>
--	--

5.2 SLIDE REPLACEMENT (OPTION)

Excessively worn or damaged slides must be replaced (FIGURE 5.2). In order to do this raise the plough and support with sufficiently stable and strong supports. If the plough is hitched and raised on the front three-point linkage, protect it from falling and immobilise the tractor (turn off the engine and engage the parking brake.) Remove the screw (5) extend the stand (1) from its seat (2). Check the stand and other elements for damage or excessive wear. The list of slide working components including catalogue numbers is shown in TABLE 5.3

	<p>DANGER</p> <p>Do NOT perform service or repair work under raised and unsupported machine.</p>
---	---

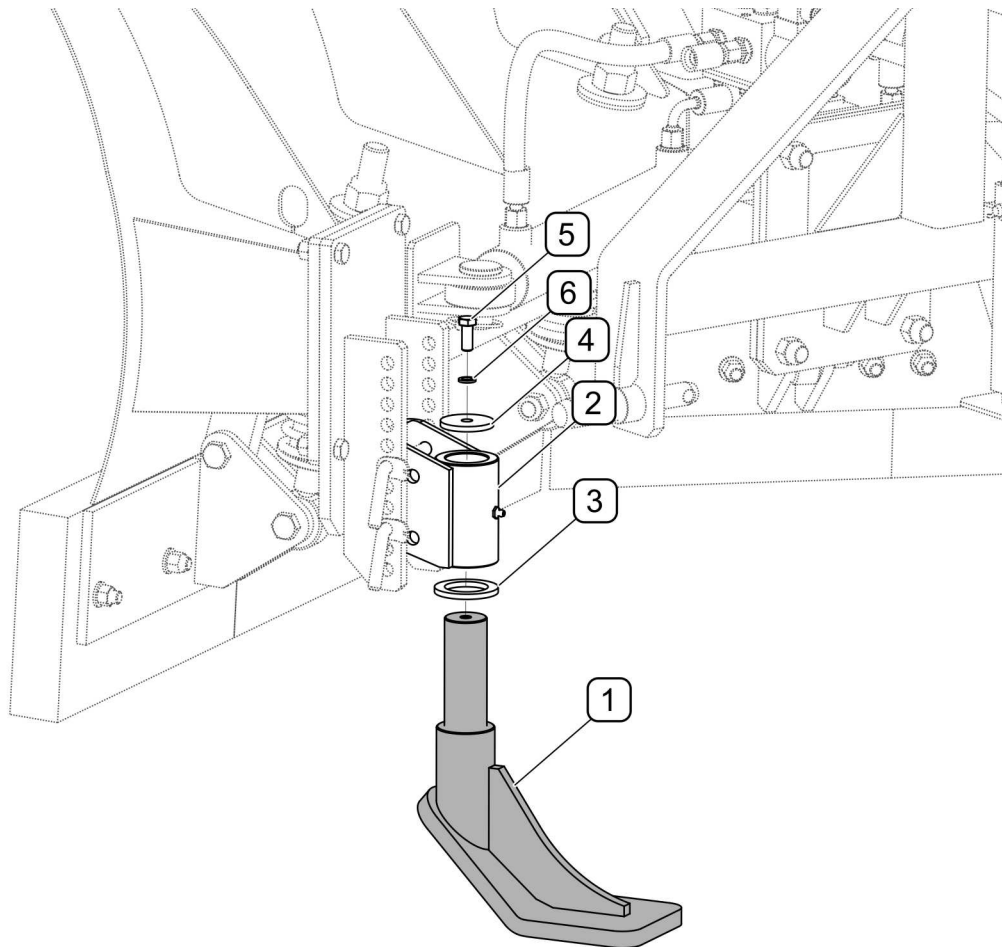

FIGURE 5.2 Slide replacement (option)

(1) - stand; (2) - socket; (3) - sliding pad; (4) - washer; (5) - screw; (6) - spring washer;

TABLE 5.3 THE LIST OF SLIDE WORKING COMPONENTS IN PU-1700/2100 PLOUGHS

Marking FIGURE 5.2	Name / Catalogue No.	Number of items
1	Stand / 17RPN-10.01.00.00	1
2	Socket / 17RPN-10.02.00.00	1
3	Sliding pad / 17RPN-10.00.00.02	1
4	Washer / 17RPN-10.00.00.01	1

5.3 HYDRAULIC SYSTEM OPERATION

The duties of the operator connected with the hydraulic system include:

- checking tightness of cylinders hydraulic connections,
- Checking technical condition of hydraulic connections and quick couplers;



DANGER

Do not repair hydraulic system on your own. All hydraulic system repairs must be performed only by suitably qualified personnel.



ATTENTION!

Before you begin, visually inspect the hydraulic system components.

In a new machine, the hydraulic system is filled with HL32 hydraulic oil. The oil applied because of its composition is not classified as a dangerous substance, however long-term action on the skin or eyes may cause irritation. In the event of contact of oil with skin wash the place of contact with water and soap. Do NOT apply organic solvents (petrol, kerosene). Contaminated clothing should be changed to prevent access of oil to skin. In the event of contact of oil with eye, rinse with large quantity of water and in the event of the occurrence of irritation consult a doctor. Hydraulic oil in normal conditions is not harmful to the respiratory tract. A hazard only occurs when oil is strongly atomised (oil vapour), or in the case of fire during which toxic compounds may be released.



DANGER

Oil fires should be quenched with carbon dioxide (CO₂), foam or extinguisher steam. Do NOT use water for fire extinguishing.

Spilt oil should be immediately collected and placed in marked tight container. Used oil should be taken to the appropriate facility dealing with the re-use of this type of waste.

The hydraulic system should be completely tight sealed. Inspect the seals when hydraulic ram cylinders are completely extended. In the event of confirmation of oil on hydraulic ram cylinder bodies ascertain origin of leak. Minimum leaks are permissible with symptoms of "sweating", however in the event of noticing leaks in the form of "droplets" stop using the machine until faults are remedied.



The condition of hydraulic system should be inspected regularly while using the machine.



DANGER

Before commencing whatever work on hydraulic system reduce the residual pressure in the system.



DANGER

During work on hydraulic systems use the appropriate personal protection equipment i.e. protective clothing, footwear, gloves and eye protection. Avoid contact of skin with oil.

In the event of confirmation of an oil leak on hydraulic conduit connections, tighten connections, and if this does not remedy faults then change conduit or connection elements. Change of sub assemblies is equally required in each instance of mechanical damage.



ATTENTION!

The hydraulic system is vented automatically during machine operation.



Hydraulic conduits should be replaced after 4 years of machine use.

5.4 LUBRICATION

Machine lubrication should be performed with the aid of a manually or foot operated grease gun, filled with generally available permanent grease. Before commencing lubrication insofar as is possible remove old grease and other contamination. Remove and wipe off excess oil or grease ŁT-43-PN/C-96134 permanent grease is recommended for lubrication.

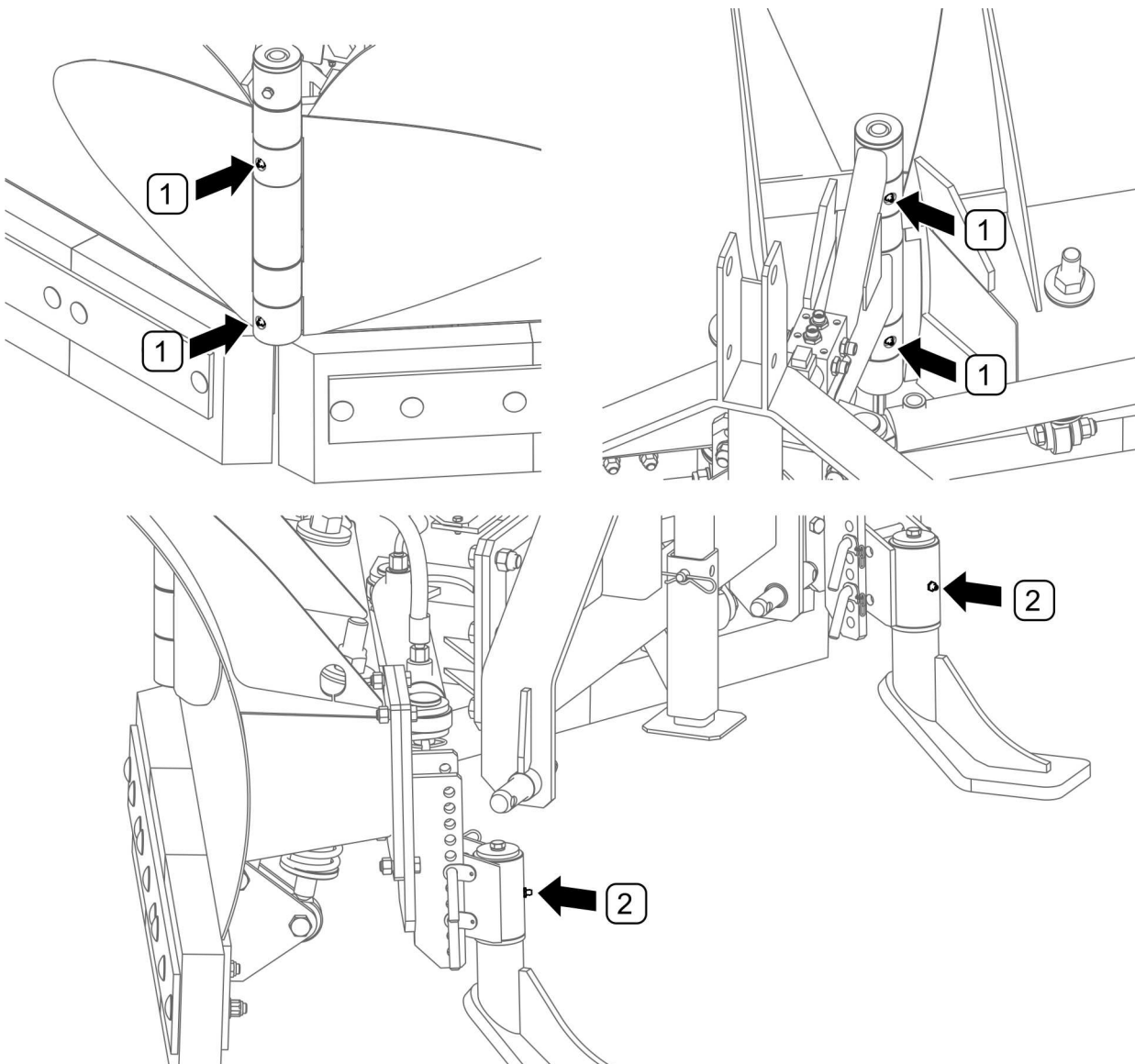

FIGURE 5.3 Lubrication points

Lubrication points described in table 5.4

TABLE 5.4 LUBRICATION POINTS AND LUBRICATION FREQUENCY

ITEM	NAME	NUMBER OF LUBRICATION POINTS	TYPE OF GREASE	LUBRICATION FREQUENCY
1	Blade main pivot pin	4	permanent grease	50 hours
2	Sliding sleeves (optional)	2	permanent grease	50 hours

Marking description in Item column (TABLE 5.4) conforms with numbering shown (FIGURE 5.3)



When using the mower the user is obliged to observe lubrication instructions according to attached schedule. Excess lubrication substance causes depositing additional contaminants in places requiring lubrication, therefore it is essential to keep individual machine elements clean.

5.5 STORAGE

After finishing work, machine should be thoroughly cleaned and washed with water jet. While washing do not direct a strong water or steam jet at information and warning decals or hydraulic conduits. Nozzle of pressure or steam washer should be kept at a distance of not less than 30 cm from cleaned surface.

After cleaning, inspect the whole machine, inspect technical condition of individual elements. Used or damaged elements should be repaired or replaced.

In the event of damage to the paint coat, clean rust and dust from damaged area, degrease and then paint with undercoat and after it is dry paint with surface coat paint retaining colour uniformity and even thickness of protective coating. Until the time of touch-up painting, the damaged place may be covered with a thin layer of grease or anticorrosion preparation. Machine should be kept in closed or roofed building.

If the machine shall not be used for a long period of time, protect it against adverse weather conditions. Lubricate machine according to the instructions provided. In the event of prolonged work stoppage, it is essential to lubricate all elements regardless of the period of the last lubrication process. Additionally before the winter period hitching system pins should be smeared with grease.

5.6 TIGHTENING TORQUE FOR NUT AND BOLT CONNECTIONS

Unless other tightening parameters are given, during maintenance repair work apply appropriate torque to tightening nut and bolt connections. Recommended torque values apply to non-greased steel bolts.

	<p>ATTENTION!</p> <p>Should it be necessary to change individual parts, use only original parts or those indicated by the Manufacturer. Non-adherence to these requirements may put the user and other people's health and life at risk, and also damage the machine.</p>
---	--

TABLE 5.5 TIGHTENING TORQUE FOR NUT AND BOLT CONNECTIONS

THREAD DIAMETER [mm]	5.8	8.8	10.9
	TIGHTENING TORQUE [Nm]		
M6	8	10	15
M8	18	25	36
M10	37	49	72
M12	64	85	125
M14	100	135	200
M16	160	210	310
M20	300	425	610
M24	530	730	1,050
M27	820	1,150	1,650

5.7 TROUBLESHOOTING

TABLE 5.6 TROUBLESHOOTING

TYPE OF FAULT	CAUSE	REMEDY
Blades do not swing as you control the working position	The hydraulic system is not connected	Connect quick couplers to tractor (carrying vehicle) system.
	Damaged hydraulic quick couplers	Check quick couplers for damage, refer repair to service, if necessary
	Tractor hydraulic system unreliable switched off	Check the tractor (carrying vehicle) hydraulic system
When controlling plough setting of just one blade changes	The electrical system not connected to the tractor (carrying vehicle)	Connect electrical system to tractor.
	Hydraulic system valve control switch set in one position	When switched off, just one plough blade can be controlled, when switched on the other blade can be controlled
	Faulty wiring	Repair at authorised service point
	Damaged solenoid valve	Repair at authorised service point
	A blown fuse in the lighter socket plug (<i>only present in the system powered from the cigarette lighter</i>)	Check and replace
Plough scoops snow unevenly	Plough improperly mounted on a carrying vehicle	Check and adjust according to operator's manual
	Slide incorrectly positioned (option)	Check and adjust according to operator's manual
	Excessively worn or damaged collecting strips	Check and replace if necessary

NOTES

A series of horizontal dotted lines for writing notes.