



**PRONAR Sp. z o.o.**

17-210 NAREW, UL. MICKIEWICZA 101A, PODLASKIE PROVINCE

phone:	+48 085 681 63 29	+48 085 681 64 29
	+48 085 681 63 81	+48 085 681 63 82
fax:	+48 085 681 63 83	+48 085 682 71 10

*www.pronar.pl*

# **OPERATOR'S MANUAL**

## **DISC MOWER**

### **PRONAR PDF300 PRONAR PDF300C**

TRANSLATION OF THE ORIGINAL INSTRUCTIONS

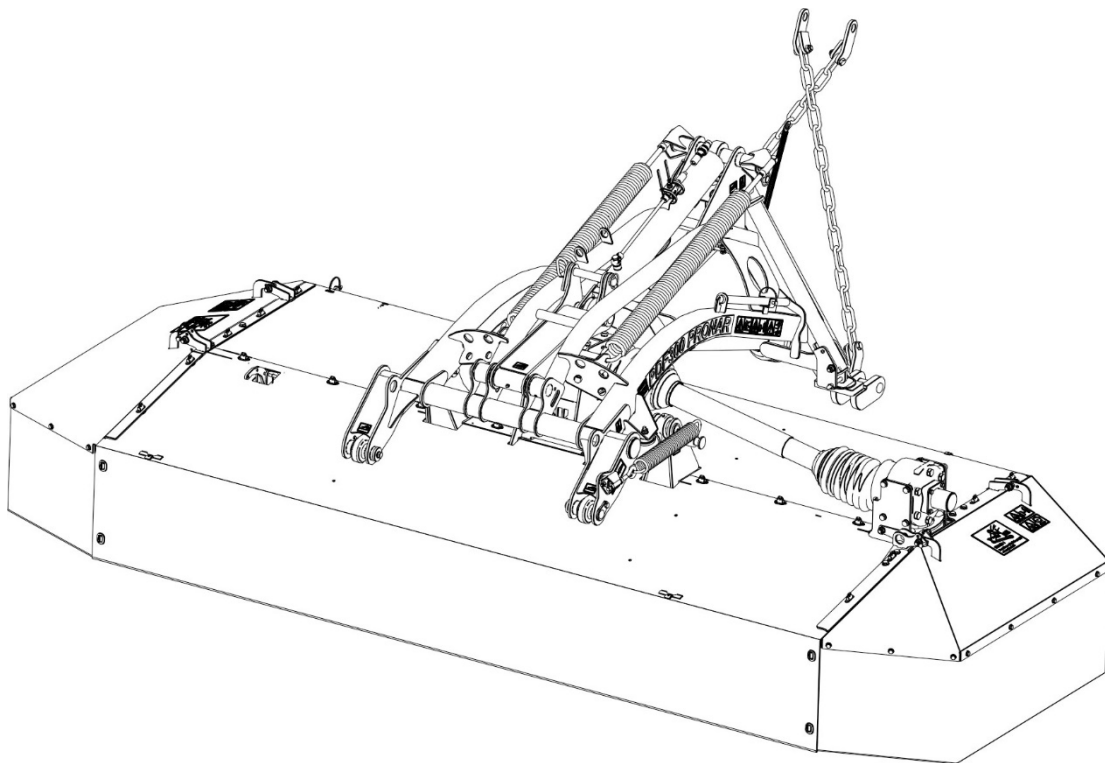

ISSUE 3A-10-2013

PUBLICATION NO. 312N-00000000-UM





# DISC MOWER

**PRONAR PDF300**  
**PRONAR PDF300C**

## MACHINE IDENTIFICATION

**SYMBOL /TYPE:**

**SERIAL NUMBER**

--	--	--	--	--	--

# INTRODUCTION

Information contained herein is current at date of publication. As a result of improvements, some numerical values and illustrations contained in this publication may not correspond to the factual specification of the machine supplied to the user. The manufacturer reserves the right to introduce design changes in machines produced that facilitate operation and improve the quality of their work, without making minor amendments to this Operator's Manual.

This Operator's Manual is an integral part of the machine's documentation. Before using the machine, the user must carefully read this Operator's Manual and observe all recommendations. This guarantees safe operation and ensures malfunction free work of the machine. The machine is designed to meet obligatory standards, documents and legal regulations currently in force.

The manual describes the basic safety rules and operation of the PRONAR PDF300 / PRONAR PDF300C disc mower. If the information stated in the Operator's Manual needs clarification then the user should refer for assistance to the sale point where the machine was purchased or to the Manufacturer.

## MANUFACTURER'S ADDRESS:

*PRONAR Sp. z o.o.  
ul. Mickiewicza 101A  
17-210 Narew*

## CONTACT TELEPHONES

*+48 085 681 63 29*

*+48 085 681 64 29*

*+48 085 681 63 81*

*+48 085 681 63 82*

## SYMBOLS APPEARING IN THIS OPERATOR'S MANUAL

Information, descriptions of danger and precautions and also recommendations and prohibitions associated with user safety instructions are marked:



and also preceded by the word "**DANGER**". Failure to observe the instructions may endanger the machine operator's or other person's health or life.

Particularly important information and instructions, the observance of which is essential, are distinguished in the text by the sign:



and also preceded by the word "**ATTENTION**". Failure to observe the instructions may lead to damage to the machine as a result of improper operation, adjustment or use.

In order to focus the user's attention on the need to perform maintenance, the relevant section of the Operator's Manual is marked with the pictogram:



Additional tips and advice for machine operation are marked:



and also preceded by the word "**TIP**".

## DIRECTIONS USED IN THIS OPERATOR'S MANUAL

Left side – side to the left hand of the operator facing in the direction of machine's forward travel.

Right side – side to the right hand of the operator facing in the direction of machine's forward travel.



**PRONAR Sp. z o.o.**

ul. Mickiewicza 101 A  
17-210 Narew, Polska

tel./fax (+48 85) 681 63 29, 681 63 81, 681 63 82,  
681 63 84, 681 64 29

fax (+48 85) 681 63 83

<http://www.pronar.pl>

e-mail: [pronar@pronar.pl](mailto:pronar@pronar.pl)

## EC DECLARATION OF CONFORMITY OF THE MACHINERY

PRONAR Sp. z o.o. declares with full responsibility, that the machine:

Description and identification of the machinery		
Generic denomination and function:	<b>Disc Mower</b>	
Type:	<b>PDF300</b>	<b>PDF300C</b>
Model:	–	–
Serial number:		
Commercial name:	<b>Disc Mower PRONAR PDF300</b> <b>Disc Mower PRONAR PDF300C</b>	

to which this declaration relates, fulfills all the relevant provisions of the Directive **2006/42/EC** of The European Parliament and of The Council of 17 May 2006 on machinery, and amending Directive 95/16/EC (Official Journal of the EU, L 157/24 of 09.06.2006).

The person authorized to compile the technical file is the Head of Research and Development Department at PRONAR Sp. z o.o., 17-210 Narew, ul. Mickiewicza 101A, Poland.

This declaration relates exclusively to the machinery in the state in which it was placed on the market, and excludes components which are added and/or operations carried out subsequently by the final user.

Narew, the 29 MAJ 2013

*Place and date*

Z-CIA DYREKTORA  
d/s technicznych  
działek zarządu

*Roman Ouzelianiuk*

*Full name of the empowered person  
position, signature*

# TABLE OF CONTENTS

<b>1</b>	<b>BASIC INFORMATION</b>	<b>1.1</b>
1.1	IDENTIFICATION	1.2
1.2	PROPER USE	1.3
1.3	EQUIPMENT	1.5
1.4	TERMS & CONDITIONS OF WARRANTY	1.5
1.5	TRANSPORT	1.7
1.6	ENVIRONMENTAL HAZARDS	1.10
1.7	WITHDRAWAL FROM USE	1.10
<b>2</b>	<b>SAFETY ADVICE</b>	<b>2.1</b>
2.1	BASIC SAFETY RULES	2.2
2.1.1	USE OF MACHINE	2.2
2.1.2	HITCHING AND UNHITCHING FROM CARRYING VEHICLE	2.3
2.1.3	HYDRAULIC SYSTEM	2.4
2.1.4	TRANSPORTING THE MACHINE	2.5
2.1.5	MAINTENANCE	2.6
2.1.6	WORK OF MOWER	2.8
2.1.7	OPERATION OF PTO SHAFT	2.9
2.2	DESCRIPTION OF RESIDUAL RISK	2.10
2.3	INFORMATION AND WARNING DECALS	2.11
<b>3</b>	<b>DESIGN AND OPERATION</b>	<b>3.1</b>
3.1	TECHNICAL SPECIFICATION	3.2
3.2	GENERAL DESIGN	3.3
3.3	LINKAGE	3.5
3.4	DRIVE ASSEMBLY AND CUTTING UNIT	3.7
3.5	HYDRAULIC SYSTEM	3.9
3.6	CONDITIONING ASSEMBLY (PDF300C)	3.10

<b>4</b>	<b>CORRECT USE</b>	<b>4.1</b>
4.1	PREPARING FOR WORK	4.2
4.2	CHECKING TECHNICAL CONDITION	4.5
4.3	HITCHING TO TRACTOR	4.6
4.4	TRANSPORTING THE MACHINE	4.10
4.5	SETTING AND MOWING	4.13
4.5.1	SETTING THE MOWER INTO THE OPERATING POSITION AND ADJUSTING THE CUTTING HEIGHT	4.13
4.5.2	ADJUSTMENT OF CUTTER BAR PRESSURE	4.15
4.5.3	SETTING THE SWATH WIDTH IN PDF300 MOWER	4.16
4.5.4	SETTING THE SWATH WIDTH IN PDF300C MOWER	4.18
4.5.5	SETTING THE SWATH CONDITIONING INTENSITY IN THE PDF300C MOWER	4.19
4.5.6	MOWING	4.21
4.6	DISCONNECTING FROM TRACTOR	4.23
4.7	LIGHTING INSTALLATION AND ADDITIONAL MARKING (OPTIONAL)	4.24
4.7.1	CONSTRUCTION	4.24
4.7.2	USAGE AND MAINTENANCE	4.25
<b>5</b>	<b>MAINTENANCE</b>	<b>5.1</b>
5.1	CHECKING AND REPLACING CUTTING BLADES	5.2
5.1.1	INSPECTION AND REPLACEMENT OF THE CUTTER BAR BLADES	5.2
5.1.2	INSPECTION AND REPLACEMENT OF SWATH CONDITIONER FLAIL BLADES (PDF300C)	5.4
5.2	DRIVE SYSTEM MAINTENANCE	5.6
5.3	CUTTERBAR MAINTENANCE	5.10
5.4	HYDRAULIC SYSTEM OPERATION	5.13
5.5	LUBRICATION	5.15



5.6	STORAGE	5.19
5.7	TIGHTENING TORQUE FOR NUT AND BOLT CONNECTIONS	5.20
5.8	TROUBLESHOOTING	5.22



*SECTION*

**1**

---

**BASIC  
INFORMATION**

## 1.1 IDENTIFICATION

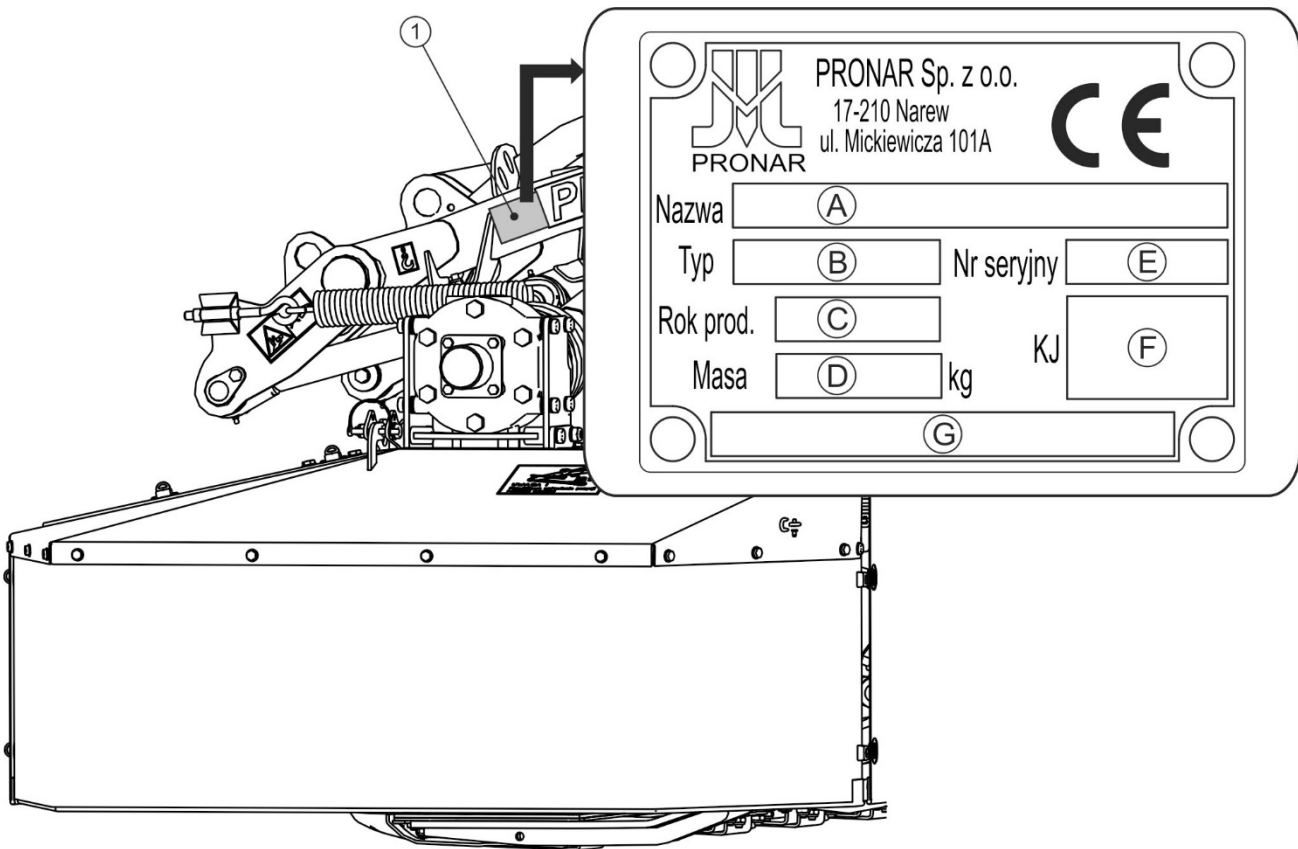

**FIGURE 1.1** Location of the data plate.

(1) data plate

The PDF300 /PDF300C front disc mower has a data plate (1) located on the left side of the linkage frame. When buying the disc mower check that the serial numbers on the machine agree with the number written in the *WARRANTY BOOK*, in the sales documents and in the *OPERATOR'S MANUAL*

The meanings of the individual fields found on the data plate (FIGURE 1.1) are presented in the table below:

- |   |                            |
|---|----------------------------|
| A - Machine name,                             | B - Machine type/symbol,   |
| C – Year of manufacture,                      | D – Machine tare weight,   |
| E – Serial number,                            | F – Quality Control stamp, |
| G – Unfilled box or extension of name (box A) |                            |

## 1.2 PROPER USE

The PDF300 /PDF300C front disc mower is constructed according to current safety requirements and engineering standards.

The PDF300 / PDF300C front disc mower is designed to cut low stemmed green fodder (grass, lucerne, etc) on stone free cultivated fields with a level surface. Swath conditioner in PDF300C mower breaks the mown plant stalks and also removes layer of wax from the plant, which effectively accelerates the drying process. Transporting people, animals or other materials is forbidden and regarded as contrary to the intended purpose. During the use of the machine comply with all road traffic regulations and transport regulations in force in the given country, and any breach of these regulations is regarded by the Manufacturer as use contrary to its intended purpose.

### IMPORTANT



The mower must not be used for purposes other than those for which it is intended, in particular:

- for transporting people and animals,
- for transport of whatever materials or objects.

Using it as intended involves all actions connected with the safe and proper operation and maintenance of the machine. In connection with this the user is obliged to:

- carefully read the *OPERATOR'S MANUAL* and comply with its recommendations,
- understand the machine's operating principle and how to operate it safely and correctly,
- adhere to the established maintenance and adjustment plans,
- comply with general safety regulations while working,
- prevent accidents,
- comply with the road traffic regulations and transport regulations in force in a given country, in which the machine is used,
- carefully read the Operator's Manual and comply with its recommendations,

Unauthorised repairs and modifications of the machine without prior consent of the Manufacturer will be regarded as use contrary to the intended purpose. The machine may

only be used by appropriately trained users, who are aware of the dangers, design and operation of the machine. Repairs to the machine shall only be made by qualified personnel (in the warranty period all repairs must be performed in the warranty service, indicated by the Manufacturer). Maintenance and repairs that can be performed by the user, are described in SECTION 5 „MAINTENANCE”.

**TABLE 1.1 Agricultural tractor's requirements**

CONTENTS	UNIT	REQUIREMENTS
<b>Hydraulic system</b> Hydraulic oil: Pressure rating of the system Hydraulic connections	- MPa -	AGROL U 16 Front hydraulic connection or access to rear connection
<b>Implement suspension system (TPL - three-point linkage)</b> Front three point linkage system	-	Category II according to ISO 730
<b>Power take-off shaft (PTO)</b> Rotation speed Number of splines on PTO shaft	RPM pc.	1,000 6
<b>Other requirements</b> Minimum power - PDF300 - PDF300C	kW / Horsepower kW / Horsepower	44 / 60 55 / 75

The mower may only be used by persons, who:

- are familiar with the contents of this publication and with the contents of the agricultural tractor Operator's Manual,
- have been trained in mower service and safe operation,
- have the required authorisation to drive and are familiar with the road traffic regulations and transport regulations.

## 1.3 EQUIPMENT

**TABLE 1.2 Mower equipment**

EQUIPMENT	STANDARD	OPTION
Operator's Manual	•	
Warranty book	•	
„Comer T401110ENC12F12” PTO shaft 1-3/8" Z6	•	
„B&P 7G4N111CE008N14” PTO shaft 1-3/8" Z21		•
Lighting installation		•

## 1.4 TERMS & CONDITIONS OF WARRANTY

PRONAR Sp. z o.o., Narew guarantees the reliable operation of the machine when it is used according to its intended purpose as described in the *OPERATOR'S MANUAL*. Defects discovered during the warranty period will be removed by the Warranty Service. The repair period is specified in the Warranty Book.

The warranty does not apply to those parts and sub-assemblies of the machine, which are subject to wear in normal usage conditions, regardless of the warranty period. Consumables include the following parts/sub-assemblies:

- working discs and slides
- cutting blades and pins securing cutting knives,
- tarpaulin covers,
- bearings.

The warranty service only applies to factory defects and mechanical damage that is not due to the user's fault.

In the event of damage arising from:

- mechanical damage which is the user's fault, caused by road accidents,

- by inappropriate use, adjustment or maintenance, use of the machine for purposes other than those for which it is intended,
- use of damaged machine,
- repairs carried out by unauthorised persons, improperly carried out repairs,
- making unauthorised alterations to machine design,

the user will lose the right to warranty service.



### **TIP**

**Demand that the seller carefully and precisely fills out the Warranty Book and warranty repair coupons. A missing date of purchase or sale point stamp, may make the user ineligible for any warranty repair or refund.**

The user is obliged to report immediately on noticing any wear in the paint coating or traces of corrosion, and to have the faults rectified whether they are covered by the warranty or not. For detailed Terms & Conditions of Warranty, please refer to the WARRANTY BOOK attached to each machine.

Modification of the mower without the written consent of the Manufacturer is forbidden. In particular, do NOT weld, drill holes in, cut or heat the main structural elements of the machine, which have a direct impact on the machine operation safety.



## 1.5 TRANSPORT

The mower is ready for sale completely assembled and does not require packing. Solely the operation and maintenance documentation of the machine and possibly flexible guards for additional equipment require packing.

### IMPORTANT



Before transporting independently, the tractor driver must carefully read this operator's manual and observe its recommendations. When being transported on a motor vehicle the mower must be mounted on the vehicle's platform in accordance with the transport safety requirements. The driver of the vehicle should take particular care while driving. This is due to the vehicle's centre of gravity shifting upwards when loaded with the machine.

Delivery is either by transport on a vehicle or independently. Transport of the mower is permissible connected to a tractor provided the tractor's driver familiarises himself with the machine's Operator's Manual and particularly with information concerning safety and principles of connection and transport of mower on public roads. Do NOT drive the tractor with mower connected when visibility is limited. During independent transport by road the mower should always be set in transport position properly secured - see SECTION 4.4 "*TRANSPORTING THE MACHINE*". Comply with the regulations of the traffic regulations concerning lights and indicators.

When loading and unloading the mower, comply with the general principles of workplace health and safety for reloading work. Persons operating reloading equipment must have the qualifications required to operate these machines. Only use lifting equipment with a lifting capacity greater than the weight of the mower given on the data plate. This also applies to cables, belts and chains used during reloading.

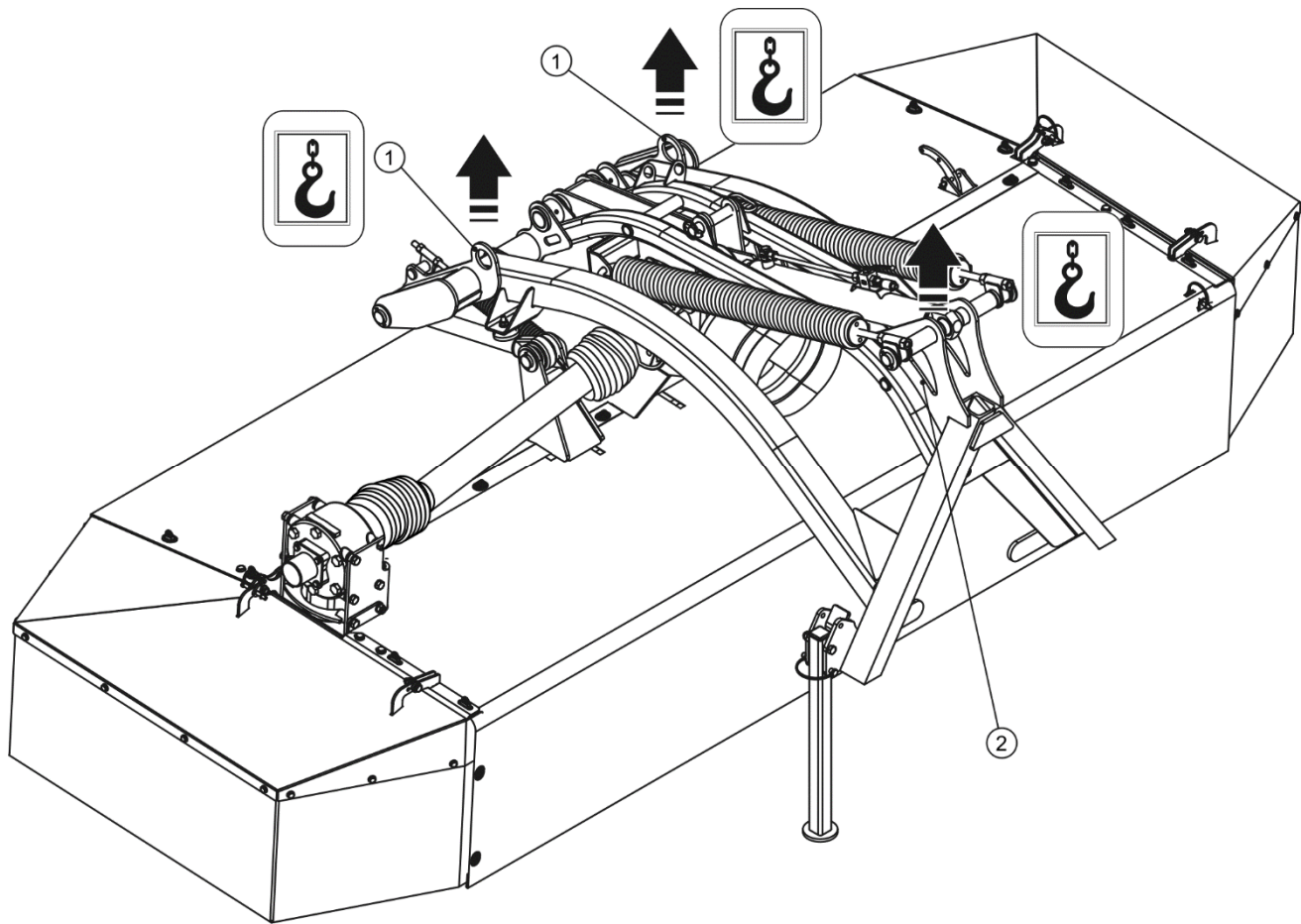

**FIGURE 1.2** Transport lugs.

(1)- transport lug, (2)- transport straps fixing eye

The mower should be attached to lifting equipment in places designed for this purpose (FIGURE 1.2), i.e. to transport lug (1) and hole (2) in the linkage frame. When lifting the mower take particular care due to the possibility of tipping over the machine and the risk of injuries from protruding parts.

	<b>DANGER</b>
Nobody may be in the manoeuvring zone during transferring mower to other form of transport.	

	<b>TIP</b>
When loading with lifting equipment, put the mower in its transport position and lock it. Support leg should be lowered and secured with a pin.	

The machine should be attached firmly to the platform of the vehicle using straps or chains fitted with a tightening mechanism. The fastening equipment used must have a valid safety certificate. Exercise particular caution when lifting the machine. To keep lifted machine in the correct direction it is recommended to apply additional guy cables. During the loading work particular care should be taken not to damage paint coating.



### IMPORTANT

Do NOT secure lifting slings or any types of securing elements to hydraulic cylinders.

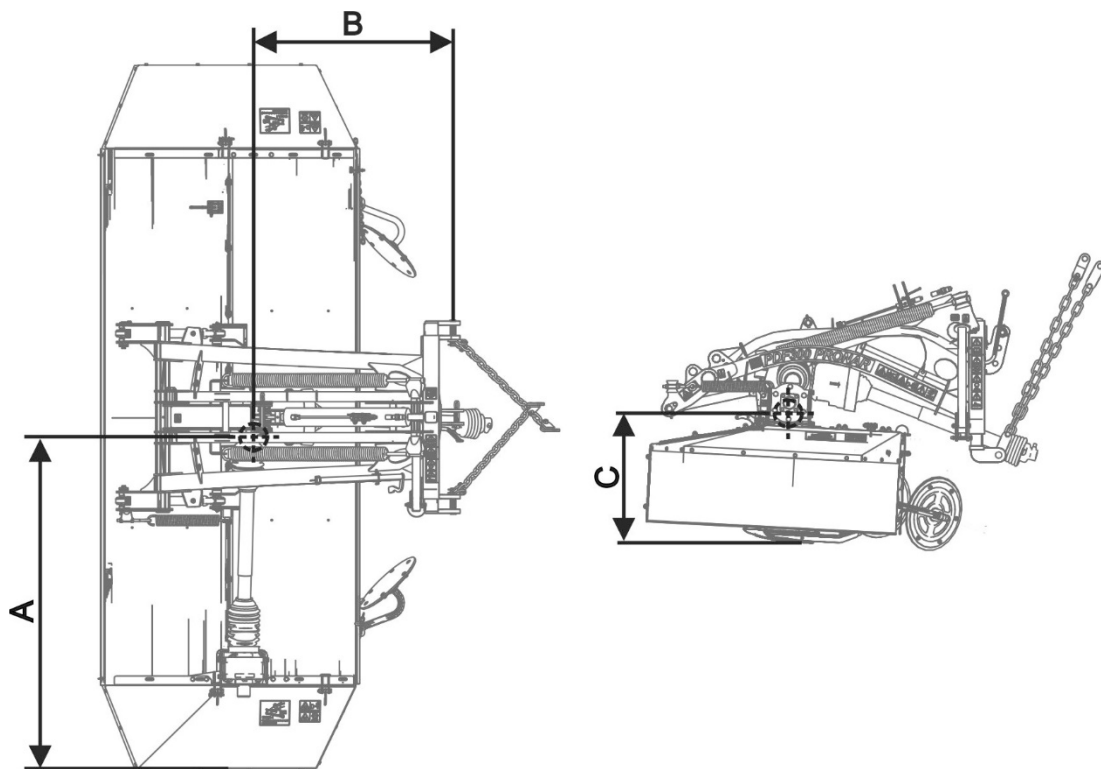

FIGURE 1.3 Location of centre of gravity of the PDF300 / PDF300C mower.

TABLE 1.3 Centre of gravity.

Dimension (FIGURE 1.3)	Unit	Mower model	
		PDF300	PDF300C
A	mm	1690	1670
B	mm	895	850
C	mm	525	510

## 1.6 ENVIRONMENTAL HAZARDS

A hydraulic oil leak constitutes a direct threat to the natural environment owing to its limited biodegradability. While carrying out maintenance and repair work which involves the risk of an oil leak, this work should take place on an oil resistant floor or surface. In the event of oil leaking into the environment, first of all contain the source of the leak, and then collect the leaked oil using available means. Remaining oil should be collected using sorbents, or by mixing the oil with sand, sawdust or other absorbent materials. The oil pollution, once gathered up, should be kept in a sealed, marked, hydrocarbon resistant container, and then passed on to the appropriate oil waste recycling centre. The container should be kept away from heat sources, flammable materials and food.

Oil, which has been used up or is unsuitable for further use owing to a loss of its properties should be stored in its original packaging in the conditions described above.

## 1.7 WITHDRAWAL FROM USE

In the event of decision by the user to withdraw the machine from use, comply with the regulations in force in the given country concerning withdrawal from use and recycling of machines withdrawn from use.

Before proceeding to dismantle equipment oil shall be completely removed from hydraulic system, cutting blades and transmission. Locations of drain plugs and method for draining oil are described in SECTION 5.

When spare parts are changed, worn out or damaged parts should be taken to a collection point for recyclable raw materials. Waste oil and also rubber and plastic elements should be taken to establishments undertaking the utilisation of such waste.



### **IMPORTANT**

**During dismantling personal protection equipment shall be used i.e. protective clothing, boots, gloves and protective goggles etc.**

**Avoid contact of skin with oil. Do not allow used oil to spill.**

**SECTION**

**2**

---

**SAFETY  
ADVICE**

## 2.1 BASIC SAFETY RULES

### 2.1.1 USE OF MACHINE

- Before using the machine, the user must carefully read this Operator's Manual and the *WARRANTY BOOK*. When operating the machine, the operator must comply with the recommendations.
- The mower may only be used and operated by persons qualified to drive agricultural tractors and agricultural machines and trained in the use of the machine.
- If the information stated in the Operator's Manual is difficult to understand, contact a seller, who runs an authorised technical service on behalf of the Manufacturer, or contact the Manufacturer directly.
- Careless and improper use and operation of the machine, and non-compliance with the recommendations given in this operator's manual is dangerous to your health.
- Be aware of the existence of a residual risk, and for this reason the fundamental basis for using this machine should be the application of safety rules and sensible behaviour.
- The machine must never be used by persons, who are not authorised to drive agricultural tractors, including children and people under the influence of alcohol or other drugs.
- Non-compliance with the safety rules of this Operator's Manual can be dangerous to the health and life of the operator and others.
- The machine must not be used for purposes other than those for which it is intended. Anyone who uses the mower other than the way intended takes full responsibility for himself for any consequences of this potentially improper use. Use of the machine for purposes other than those for which it is intended by the Manufacturer may invalidate the warranty.
- The machine must not be used when not in working order.
- Do NOT leave tractor driver's seat when the tractor is moving.

- The machine may only be used when all the safety guards and other protective elements are technically sound and correctly positioned. In the event of loss or destruction of the safety guards, they must be replaced with new ones.
- In order to limit occupational risks associated with exposure to noise during mower operation use individual protection (ear protectors). In order to reduce the level of noise during work the tractor cab window and door should be closed.

### **2.1.2 HITCHING AND UNHITCHING FROM CARRYING VEHICLE**

- Do NOT link the mower to a tractor, if hydraulic oil applied in both machines are of different types, or if the three point linkage system of the mower is not compatible with the category of the linkage system of the tractor.
- To attach the machine to the tractor only the front Three-Point Linkage System may be used. After mounting the machine, check the safeguards. After completed hitching of the machine, check the safeguards. Carefully read the tractor Operator's Manual.
- To hitch the machine to tractor use only genuine pins and safeguards.
- Before hitching the machine to the tractor, check the technical condition of the hitching system of the mower and the tractor.
- The agricultural tractor to which the mower will be coupled must be technically reliable and must fulfil the requirements of mower Manufacturer.
- Be especially careful when hitching the machine.
- During hitching there must be nobody between the mower and the tractor. A person assisting in the hitching of the machine should stand in such a place (beyond the area of danger), in order to be continuously visible to the tractor driver.
- Do NOT unhitch the mower from the tractor if the cutting system is raised. Exercise caution when unhitching the machine.
- Hitching and unhitching may only take place when the cutting head and the tractor are switched off.
- Reduce pressure prior to disconnecting the hydraulic system.

- Mower uncoupled from the tractor must be supported with the aid of supports and pin must be protected.

### **2.1.3 HYDRAULIC SYSTEM**

- The hydraulic system is under high pressure when operating.
- Regularly check the technical condition of the connections and the hydraulic conduits. There must be no oil leaks.
- In the event of the hydraulic system malfunction, discontinue using the machine until the malfunction is corrected.
- When connecting the hydraulic lines to the tractor, make sure that the tractor hydraulic system and mower are not under pressure. If necessary reduce residual pressure in the system.
- In the event of injuries being caused by pressurised hydraulic oil, contact a doctor immediately. Hydraulic oil may find its way under the skin and cause infections. In the event of contact of oil with eye, rinse with large quantity of water and in the event of the occurrence of irritation consult a doctor. In the event of contact of oil with skin wash the area of contact with water and soap. Do NOT apply organic solvents (petrol, kerosene).
- Use the hydraulic oil recommended by the Manufacturer. Never mix two types of oil.
- After changing the hydraulic oil, the used oil should be properly disposed of. Used oil or oil, which has lost its properties, should be stored in original containers or replacement containers resistant to action of hydrocarbons. Replacement containers must be clearly marked and appropriately stored.
- Do not store hydraulic oil in packaging designed for storing food or foodstuffs.
- Rubber hydraulic conduits must be replaced every 4 years regardless of their technical condition.
- Repair and replacement of hydraulic system elements should be entrusted to the appropriately qualified persons.



### 2.1.4 TRANSPORTING THE MACHINE

- When driving on public roads, comply with the road traffic regulations in force in the country, in which the machine is used.
- Do not exceed the permitted speed arising from road conditions and design limitations. Adjust travel speed to the prevailing road conditions and other limitations arising from road traffic regulations limits.
- Before beginning to work, the mower must be placed in transport position and raised using the front three-point linkage system.
- Do NOT leave machine raised and unsecured while the tractor is parked. When parked, the machine should be lowered.
- Do not transport the machine with the cutting assembly set in the working position.
- Cutting assembly lock must be always engaged during transport.
- During transport the hydraulic cylinder cut-off valve should be set in the closed position.
- During transport disconnect PTO shaft from tractor.
- The mower may not be used or transported in conditions of limited visibility.
- Do NOT ride on the machine or transport any materials on it.
- Before using the machine always check its technical condition, especially in terms of safety. In particular check the technical condition of the linkage, cutting unit, fastening of cutting blades, protective guards and connection components for hydraulic systems.
- Reckless driving and excessive speed may cause accidents.

### 2.1.5 MAINTENANCE

- During the warranty period, any repairs may only be carried out by Warranty Service authorised by the manufacturer. It is recommended that necessary repairs to machine should be undertaken by specialised workshops. Repair work at the mower should be carried out by persons trained and entitled to do so.
- In the event of any fault or damage whatsoever, do not use the mower until the fault has been corrected. The machine must not be used when not in working order.
- During work use the proper, close-fitting protective clothing, gloves and appropriate tools. When working on hydraulic systems it is recommended to use oil resistant gloves and protective goggles.
- Any modification to the machine frees the manufacturer from any responsibility for damage or detriment to health which may arise as a result.
- Before undertaking any work on the mower disconnect tractor engine and wait until all rotating parts come to a stop.
- Regularly check the technical condition of the safety devices and correct tightening of bolt connections.
- Regularly perform service inspections of machine as recommended by the Manufacturer.
- Do NOT perform service or repair work under raised and unsupported machine.
- Before beginning repair works on hydraulic systems, reduce oil pressure.
- Servicing and repair work should be carried out in line with the general principles of workplace health and safety. In the event of injury, the wound must be immediately cleaned and disinfected. In the event of more serious injuries, seek a doctor's advice.
- Repair, maintenance and cleaning work should be carried out with the tractor's engine turned off and the ignition key removed. Immobilise tractor with parking brake. Ensure that unauthorised persons do not have access to the tractor cab.

- Should it be necessary to change individual parts, use only original parts. Non-adherence to these requirements may put the user and other people's health and life at risk, and also damage the machine and invalidate the warranty.
- Regularly check technical condition and mounting of all guards and protective elements.
- The paint coating should be cleaned off before beginning welding work. Burning paint fumes are poisonous for people and animals. Welding work should be carried out in a well lit and well ventilated space.
- During welding work pay attention to flammable or fusible elements (parts of the hydraulic systems, plastic parts). If there is a risk that they will catch fire or be damaged, they should be removed or covered with non-flammable material before commencing welding work. The mower must be disconnected from the tractor before commencing electric welding. Before beginning work, prepare a CO<sub>2</sub> or foam extinguisher.
- In the event of work requiring the mower to be raised, use properly certified hydraulic or mechanical lifts for this purpose. After lifting the machine, stable and durable supports must also be used. Do NOT carry out work under a machine, which has been raised only with the three point linkage.
- The machine must not be supported using fragile elements (bricks or concrete blocks).
- After completing work associated with lubrication, remove excess oil or grease.
- Damaged, missing or worn cutting blades must be replaced in pairs in order to maintain the balance of the cutting disc.
- In order to reduce the danger of fire the machine must be kept in a clean condition.
- After finishing servicing or repair work remove all tools from the machine.

### 2.1.6 WORK OF MOWER

- Before lowering or lifting the mower mounted on the three-point linkage, make sure there are no bystanders, especially children, near the machine.
- Before starting mower drive, the cutting assembly must be in working position.
- Before starting the mower make sure that there are no bystanders (especially children) or animals in the danger zone. The machine operator is obliged to ensure proper visibility of the machine and the working area.
- Mowing should begin after reaching nominal PTO RPM of 1000 rpm. Do NOT overload shaft and mower and also do NOT engage the clutch suddenly.
- During cutting do NOT use PTO revolution speed greater than 1000 rpm.
- When mowing on the edges of streets, public roads, on stony ground there is a risk that thrown out stones and foreign bodies may pose a risk to bystanders and other vehicle passing by.
- Do NOT leave the tractor cab, when the machine drive is engaged.
- Do NOT stand within the mower's working zone.
- Do NOT approach cutting unit guards until the rotating cutting parts come to a complete standstill.
- Do NOT operate mower while reversing. While reversing raise the multifunction arm.

### 2.1.7 OPERATION OF PTO SHAFT

- While reversing and during turns, the PTO drive must be disengaged.
- The machine may only be connected to the tractor by appropriately selected PTO shaft recommended by the Manufacturer.
- Adjust the length of PTO shaft to compatible tractor according to the Operator's Manual of PTO shaft.
- The PTO shaft has markings on the casing, indicating, which end of the shaft shall be connected to the tractor.
- Never use a damaged PTO shaft, it may cause an accident. A damaged shaft must be repaired or replaced.
- Disconnect the drive shaft each time when it is not necessary to drive the machine, or when the tractor and mower are at an unsuitable angle to each other.
- The chains preventing the shaft cover from turning while the shaft is working, shall be secured to a fixed element of machine structure.
- Do NOT use the securing chains to support the shaft while machine is parked or when transporting the machine.
- Before using the machine, the user should thoroughly acquaint himself with the PTO shaft Operator's Manual and adhere to the recommendations contained in it.
- The drive shaft must be equipped with a cover. Do NOT use the shaft with damaged or missing guards.
- After connecting shaft ensure that it is correctly and safely connected to the tractor and to the mower.
- Before starting PTO shaft make certain that the PTO rotation direction is correct.
- Before disconnecting the shaft, turn off the tractor engine and remove the key from the ignition.
- Do NOT wear loose clothing, straps or whatever that may become wrapped round the rotating drive shaft. Contact with rotating PTO shaft may cause severe injuries.
- Do NOT go over and under the shaft or stand on it equally during work as also when the machine is parked.

## 2.2 DESCRIPTION OF RESIDUAL RISK

Pronar Sp. z o. o. in Narew has made every effort to eliminate the risk of accidents. There is, however, a certain residual risk, which could lead to an accident, and this is connected mainly with the actions described below:

- using the sand spreader for purposes other than those for which it is intended,
- being between the tractor and the machine while the engine is running and when the machine is being attached,
- being on the machine while the engine is running,
- operating the mower with removed or faulty safety guards,
- not maintaining safe distance from the danger zone or being within the zones while the machine is operating,
- operation of the machine by persons under the influence of alcohol,
- cleaning, maintenance and technical checks when tractor is connected and engine is running,
- making modifications to the machine without the consent of the Manufacturer,
- oil leaks and sudden movement of elements resulting from line cracking,
- using unreliable PTO shaft.



The residual risk may be kept to a minimum by following the recommendations below:



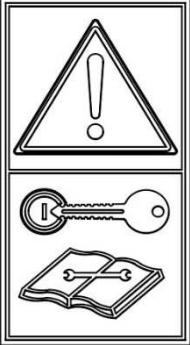

- prudent and unhurried operation of the machine,
- sensible application of the remarks and recommendations stated in the Operator's Manual,
- carrying out repair and maintenance work in line with operating safety rules,
- carrying out repair and maintenance work by persons trained to do so,
- using close fitting protective clothing,
- ensuring unauthorised persons have no access to the machine, especially children.
- maintaining safe distance from forbidden or dangerous places
- a ban on being on the machine when it is operating

## 2.3 INFORMATION AND WARNING DECALS





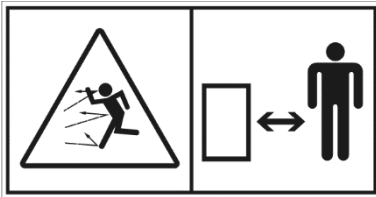

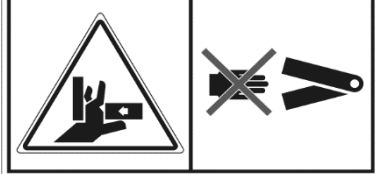
The mower is labelled with the information and warning decals mentioned in TABLE 2.1. The symbols are positioned as presented in FIGURE 2.1. Throughout the time it is in use, the user of the machine is obliged to take care that notices and warning and information symbols located on the machine are clear and legible. In the event of their destruction, they must be replaced with new ones. Safety decals are available from your PRONAR dealer or directly from PRONAR customer service. New assemblies, changed during repair, must be labelled once again with the appropriate safety signs. During cleaning do not use solvents, which may damage label covering and do not direct strong water jet at machine.



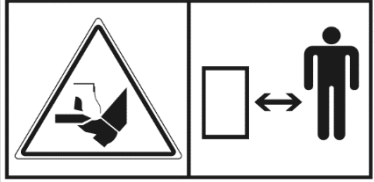

**TABLE 2.1** Information and warning decals

ITEM	DECAL	DESCRIPTION
1		Machine type (PDF300)
2		Before beginning servicing or repairs, switch off engine and remove key from ignition
3		Before starting work, carefully read the Operator's Manual.

ITEM	DECAL	DESCRIPTION
4		<p>Maximum allowable PTO shaft rotation speed is 1000 rpm.</p>
5		<p>Danger associated with the rotating PTO shaft.</p>
6		<p><b>Warning-</b> cutting elements do not approach an operating mower.</p>
7		<p>Thrown out objects endanger the whole body. Keep a safe distance from the operating machine.</p>
8		<p>Danger of hitting due to setting mower units into working or transport positions.</p>
9		<p>Do not reach into crushing space because elements may move. Danger of crushing hands or fingers</p>



ITEM	DECAL	DESCRIPTION
10		<p>Risk of injury to foot or leg. Keep a safe distance.</p>
11		<p>Do not touch any rotating elements until they come to a complete standstill.</p>
12		<p>Do NOT stand near lifting linkages during lifting or lowering.</p>
13		<p>Transport lug points marking.</p>
14		<p>Lubrication points</p>
15		<p>„IMPORTANT ! Correct setting of working position of mower.”</p>

ITEM	DECAL	DESCRIPTION
16		Machine type (PDF300C)
17		Machine type (PDF300C)
18		Note — The drive chain or toothed belt drive. Exercise particular caution. (PDF300C)
19		Caution - rotor. Exercise particular caution. (PDF300C)

Numbers in the item column correspond to decals (FIGURE 2.1; FIGURE 2.2)

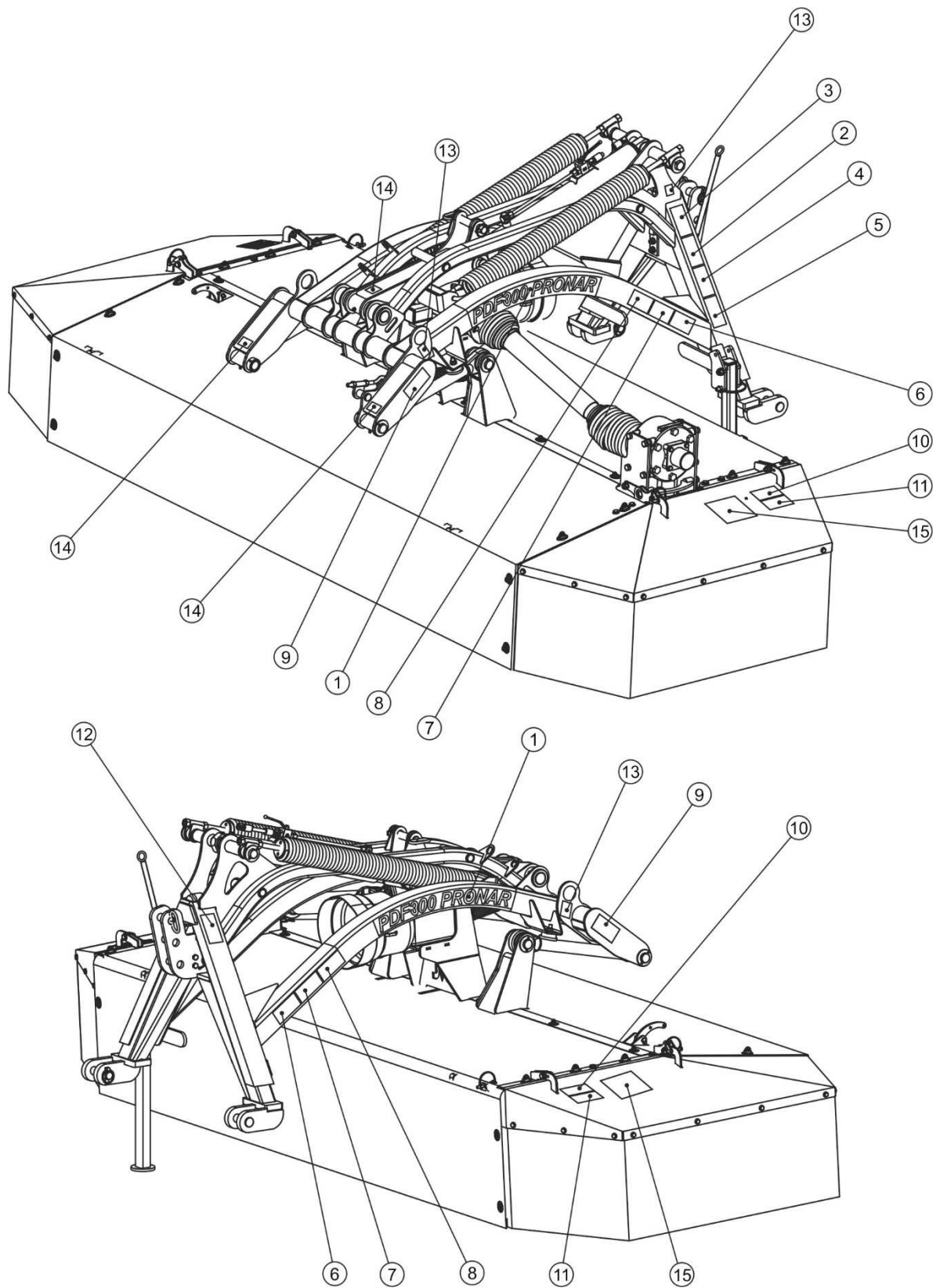

**FIGURE 2.1** Locations of information and warning decals.

*Meaning of symbols (TABLE 2.1)*

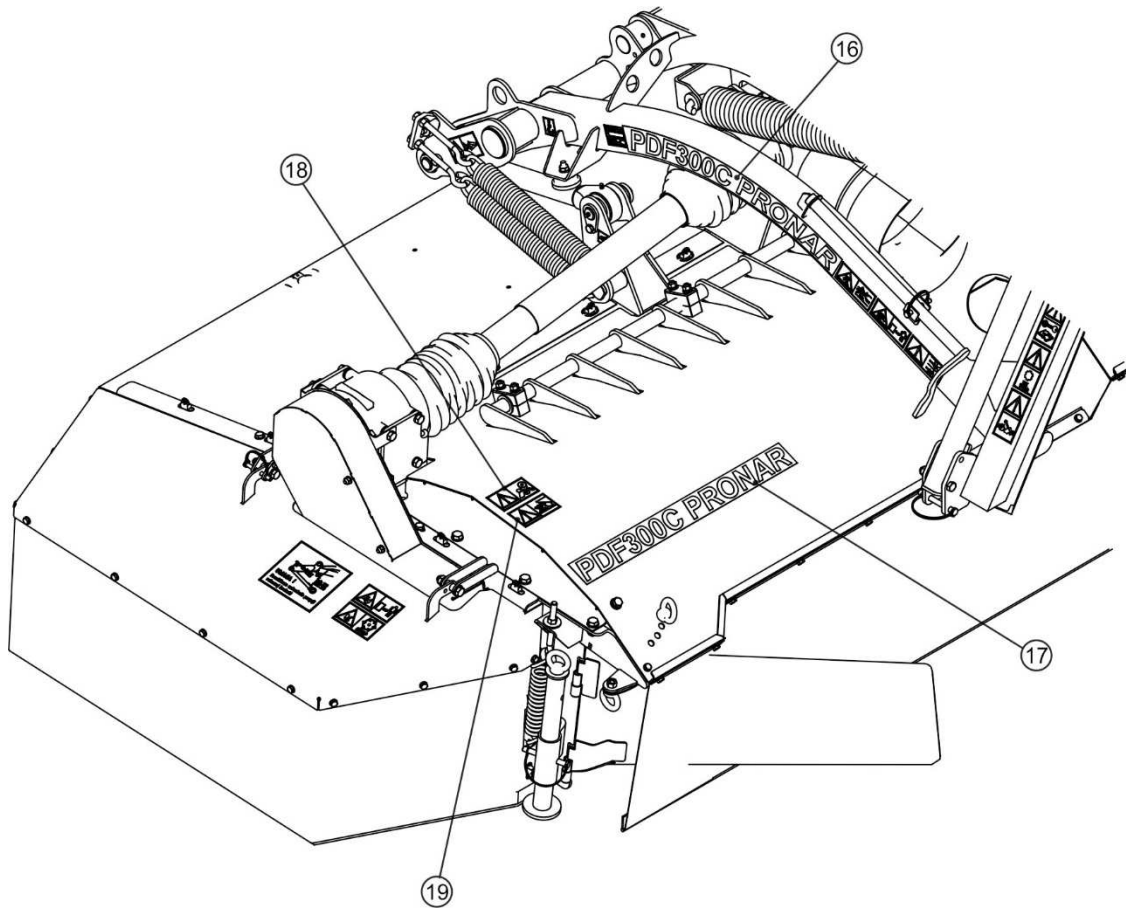

**FIGURE 2.2** Locations of information and warning decals.

*Meaning of symbols (TABLE 2.1)*

*SECTION*

**3**

---

**DESIGN  
AND OPERATION**

### 3.1 TECHNICAL SPECIFICATION

**TABLE 3.1 BASIC TECHNICAL SPECIFICATION**

	Unit	PDF300	PDF300C
<b>Dimensions</b>			
Total width in working setting	mm	3 550	
Width in transport setting	mm	3 150	3 200
Total length in transport setting	mm	1 820	
Height in transport setting:	mm	1,280	
<b>Technical specification</b>			
Cutting width	mm	3 000	
Swath width min / max	mm	1 200 / 2 000	1 500 / 2 300
Capacity (at recommended cutting speed)	ha/h	3	
Tare weight	kg	780	1 020
Minimum power demand	kW / hp	44 / 60	55 / 75
Maximum PTO speed	RPM	1,000	
PTO torque tractor-mower	Nm	900	
Linkage	-	Front three-point linkage system cat. II according to ISO 730	
Number of discs	pc.	7	
Number of cutting blades	pc.	14	
Rotation speed of discs	RPM	3,000	
Recommended mowing speed	km/h	10	
<b>Noise emission level:</b>			
L <sub>pA</sub>	dB	97	97
L <sub>Amax</sub>	dB	99	99

**L<sub>pA</sub>** – noise level exposure relating to 8 hour working day. Time averaged acoustic pressure emission level correlated with frequency characteristic A.

**L<sub>Amax</sub>** – maximum value of measurement correlated with frequency characteristic A of acoustic power level.

## 3.2 GENERAL DESIGN

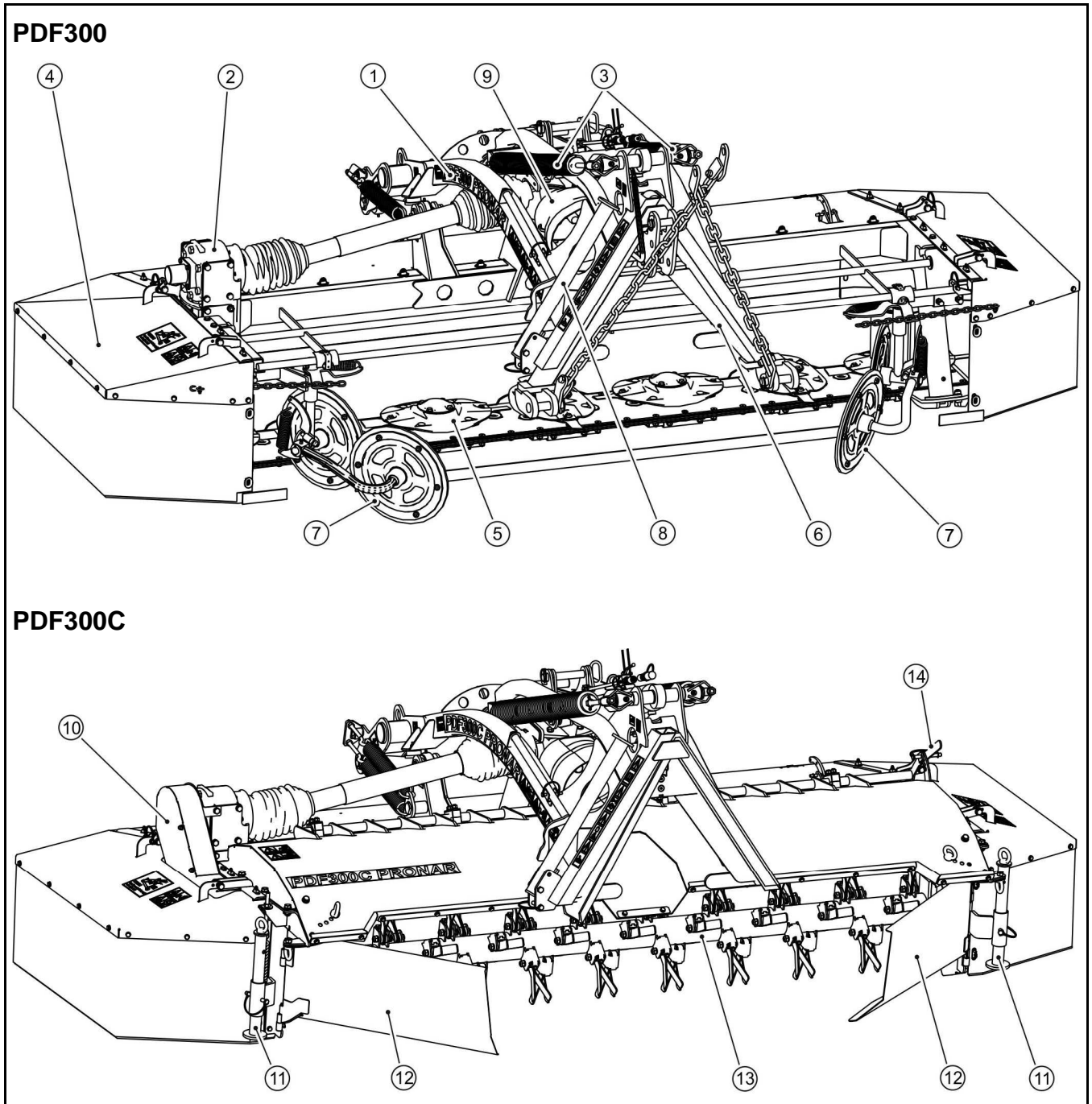

**FIGURE 3.1 General design**

(1) linkage frame, (2) cutter bar transmission, (3) stay springs, (4) main frame with guards, (5) cutter bar, (6) triangular hitching system, (7) swath guide, (8) support leg, (9) mower central transmission, (10)- swath conditioner belt drive (PDF300C), (11)- conditioning assembly supports (PDF300C), (12)- swath guides (PDF300C); (13)- conditioner shaft (PDF300C); (14)- damping fingers adjustment lever (PDF300C).

The PDF300 / PDF300C front disc mower (FIGURE 3.1) is designed to operate with a tractor equipped with a front three-point linkage and front power takeoff shaft (PTO). It consists of linkage frame (1), attached to the main frame (4) using eyes and pins. The lifting side shields, front and rear shields are secured to the main frame. Power is transmitted from the tractor to the cutting bar (5) by means of transmissions (2) and (9) and PTO shafts (SECTION 3.4 „DRIVE ASSEMBLY AND CUTTING UNIT”). Stay springs (3) ensure the cutter bar exerts uniform pressure on the ground – see (SECTION 4.5 "SETTING AND MOWING"). Adjustable swath guides (7) secured to main frame (PDF300) enable swath width to be set at widths from 1.2 m to 2.0 m.

The PDF300C mower is fitted with a conditioning assembly fixed to the mower frame behind the cutter bar (SECTION 3.6 „CONDITIONING ASSEMBLY (PDF300C)").



### 3.3 LINKAGE

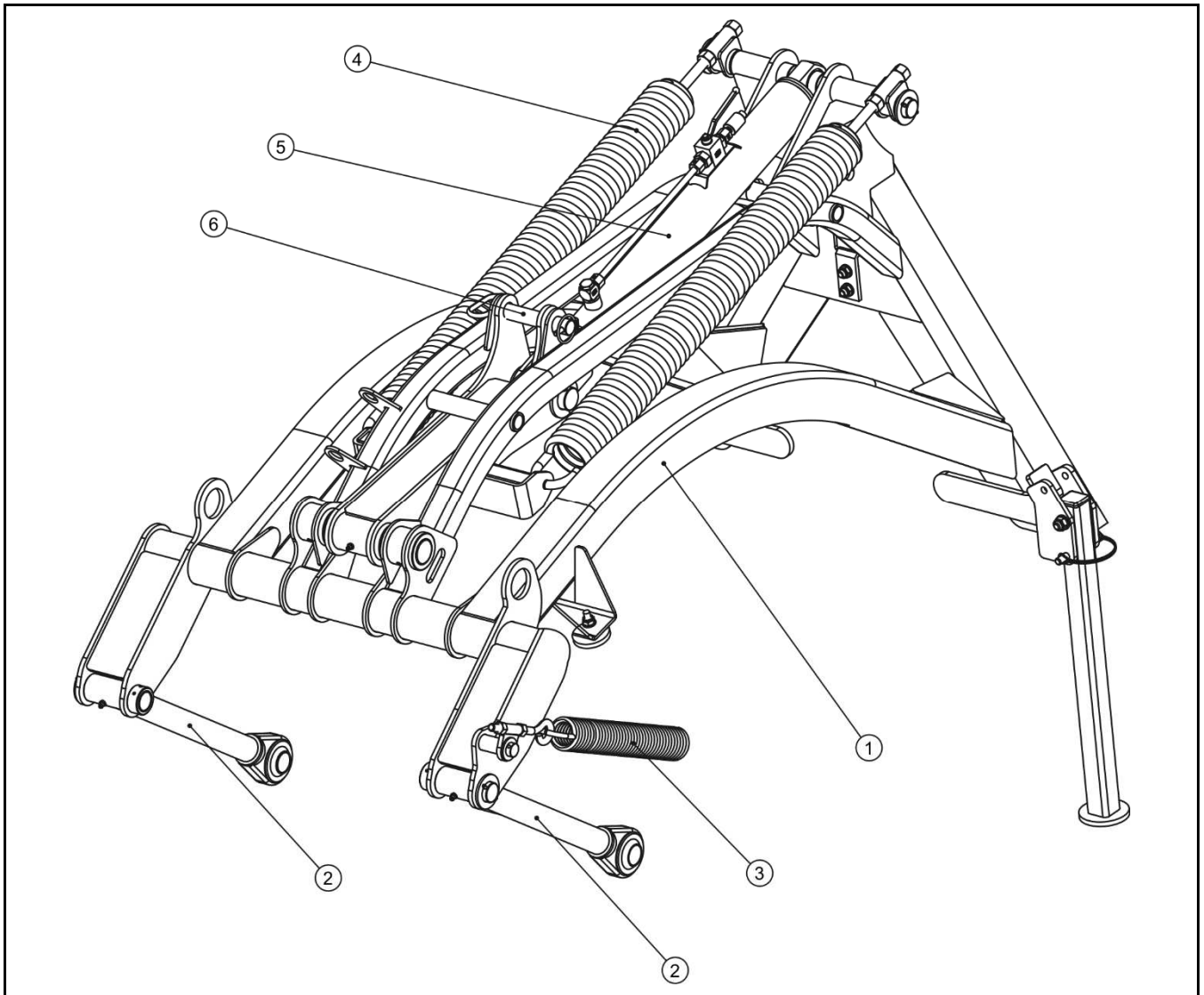
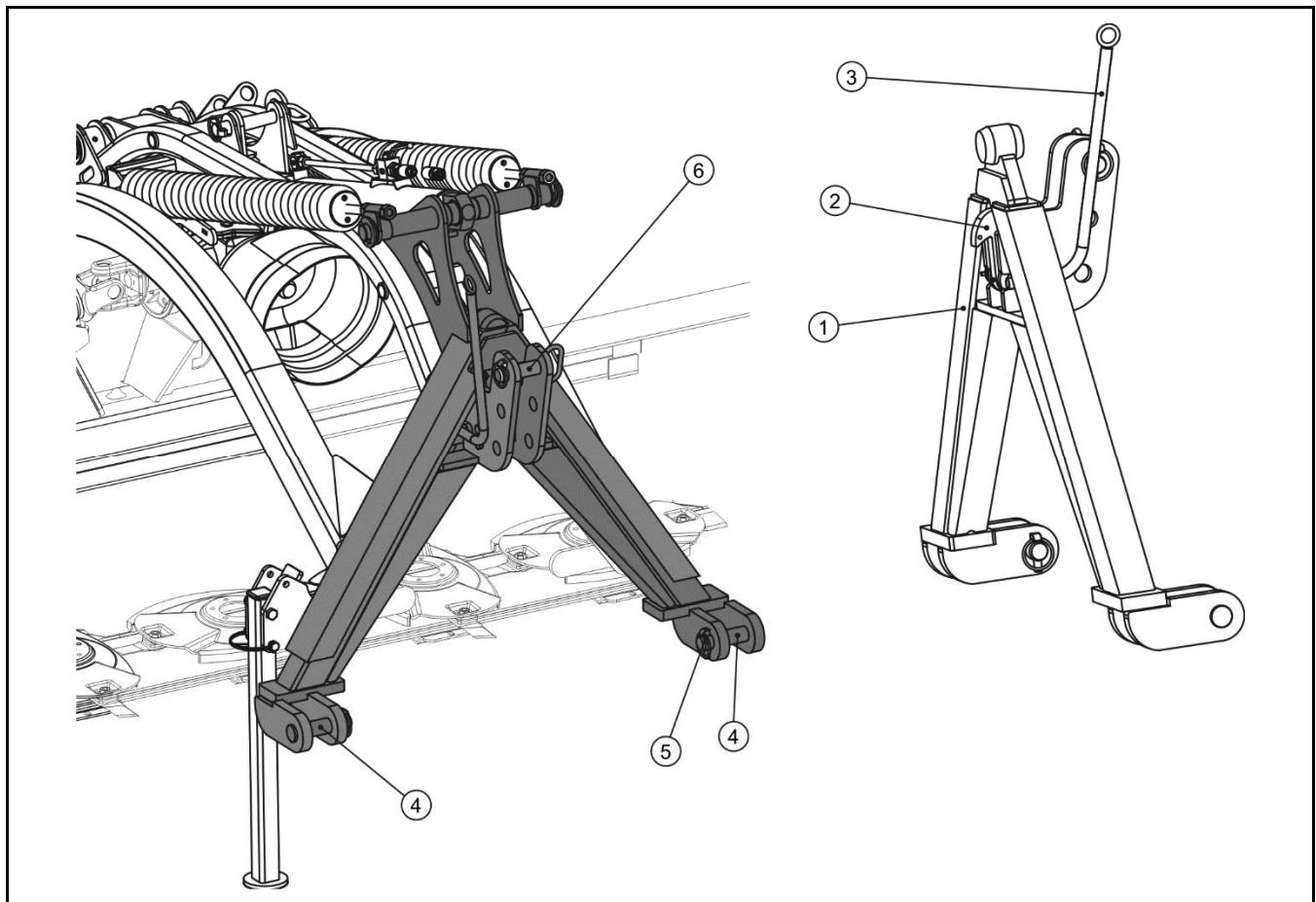

**FIGURE 3.2** Linkage design

(1) linkage frame, (2) tension rod, (3) tensioning spring, (4) stay spring, (5) hydraulic cylinder, (6) transport lock

The mower linkage (FIGURE 3.2) consists of a linkage frame (1), with tension rods (2) attached to the frame by means of rotary pins. Tension rods support the main frame with the cutting unit. The spring (3) relieves load from the left side of the mower to provide uniform pressure of the cutting unit on the ground. To ensure correct pressure of cutter bar on the surface, the machine is equipped with two strong horizontally mounted stay springs (4). These are installed in parallel to pins of the linkage frame. A spring adjustment system enables you to set an optimum pressure of the cutter bar on the type of surface and type of green forage mown etc. A hydraulic cylinder (5) is used to set the mower into the transport

position and limit the downward movement of the cutting unit. Pin (6) locks the mower in transport positions when hydraulics are operated by mistake or a hydraulic line ruptures.



**FIGURE 3.3 Hitching system**

(1) triangular hitching system, (2) catch, (3) catch lever, (4) lower arms mounting pin, (5) cotter pin, (6) upper tension rod mounting pin

Hitching system - (FIGURE 3.3) allows hitching of mower to tractor's three-point linkage. The mower is equipped with a triangular hitching system (1), which is hitched to lower hitching point of tractor's front three-point linkage using pins (4) and to upper hitching point using pin (6) and then secured with cotter pins (5). Hitching is completed once catch (2) is engaged in linkage frame. A catch lever (3) is used to disable the machine.

## 3.4 DRIVE ASSEMBLY AND CUTTING UNIT

The PDF300 mower is designed to work with PTO speed 1000 rpm and it is suitable for connection to tractors with PTO shaft revs (A) (FIGURE 3.4) turning clockwise when seen from front of tractor. To connect the machine to a tractor with PTO turning in the other direction, disassemble and turn the mower's central transmission (1) by 180° - see SECTION 4.3 "HITCHING TO TRACTOR".

Torque of tractor PTO is transferred by PTO shaft with friction clutch (4) to mower central transmission (1). From the central transmission, the drive is transmitted by shaft (3) to the cutter bar transmission (2). Then through connection to double articulated joint (6) the drive reaches the first disc on the cutter bar (5). Disc rotation direction and machine forward motion are marked with arrows. Cutting discs are fitted with left and right blades. If disks rotate clockwise then right blades are mounted, if anticlockwise then left blades are mounted - see SECTION 5.1 „CHECKING AND REPLACING CUTTING BLADES”



### ATTENTION!

Only use the machine with tractors with power of 44kW / 60 KM or more.

Do NOT use mower at PTO speeds other than 1000 rpm.

Only use PTO shafts recommended by the Manufacturer for the drive system.

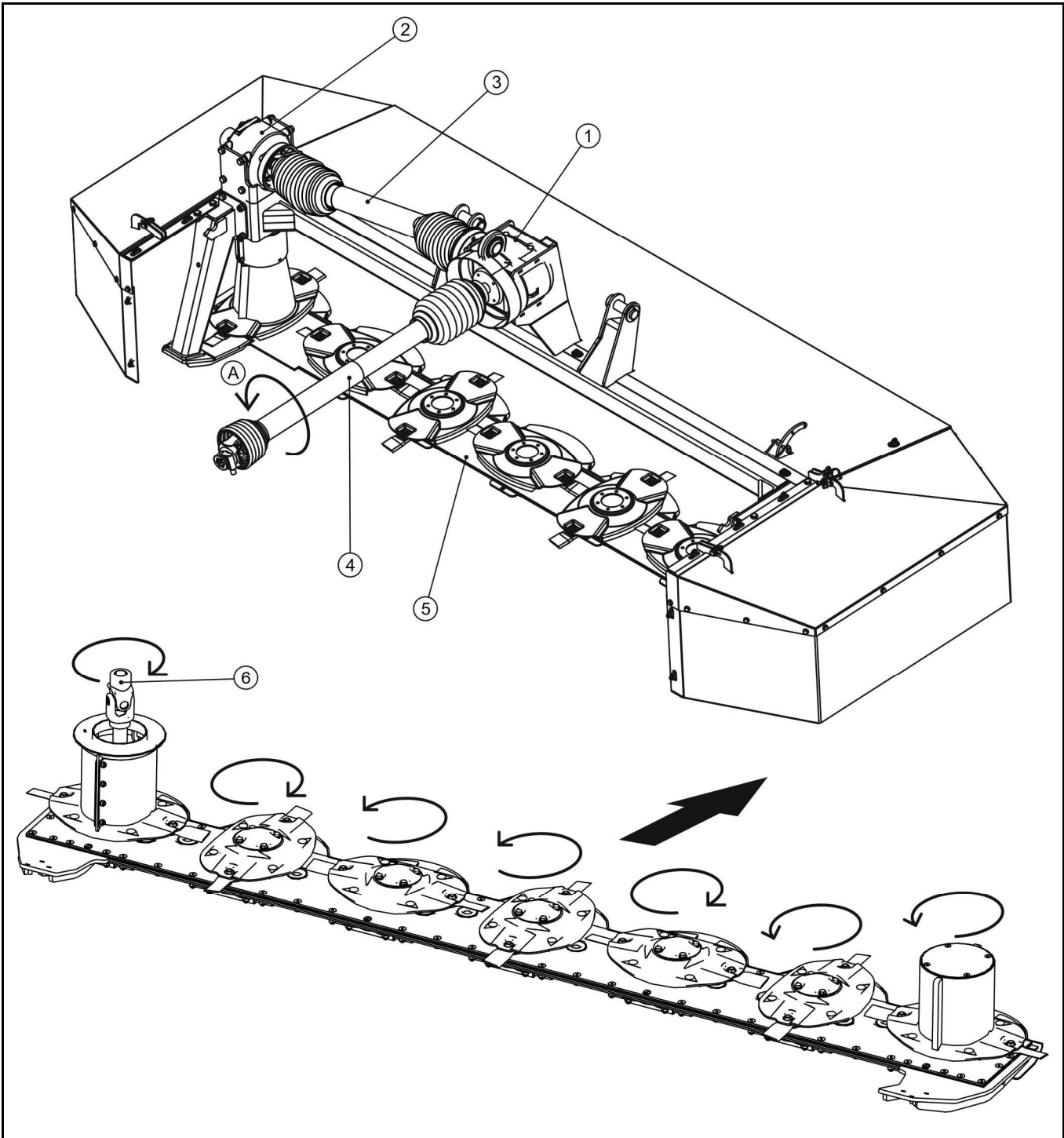

**FIGURE 3.4** Drive transmission

(1) mower central transmission, (2) cutter bar drive transmission, (3) PTO shaft, (4) PTO shaft for connection with tractor (5) cutter bar, (6) double articulated joint

### 3.5 HYDRAULIC SYSTEM

Hydraulic system (FIGURE 3.5) in PDF300 front mower allows raising and lowering of cutting unit. The machine is equipped with a single acting hydraulic cylinder (1). The cylinder is supplied from tractor's external hydraulic system connected to a quick coupler (3) by means of a hydraulic line. The hydraulic cylinder is equipped with a ball valve (2) which allows locking of the hydraulic cylinder in transport position.

The mower's hydraulic system should be connected directly to tractor external hydraulic system quick coupler socket located on tractor's front linkage.

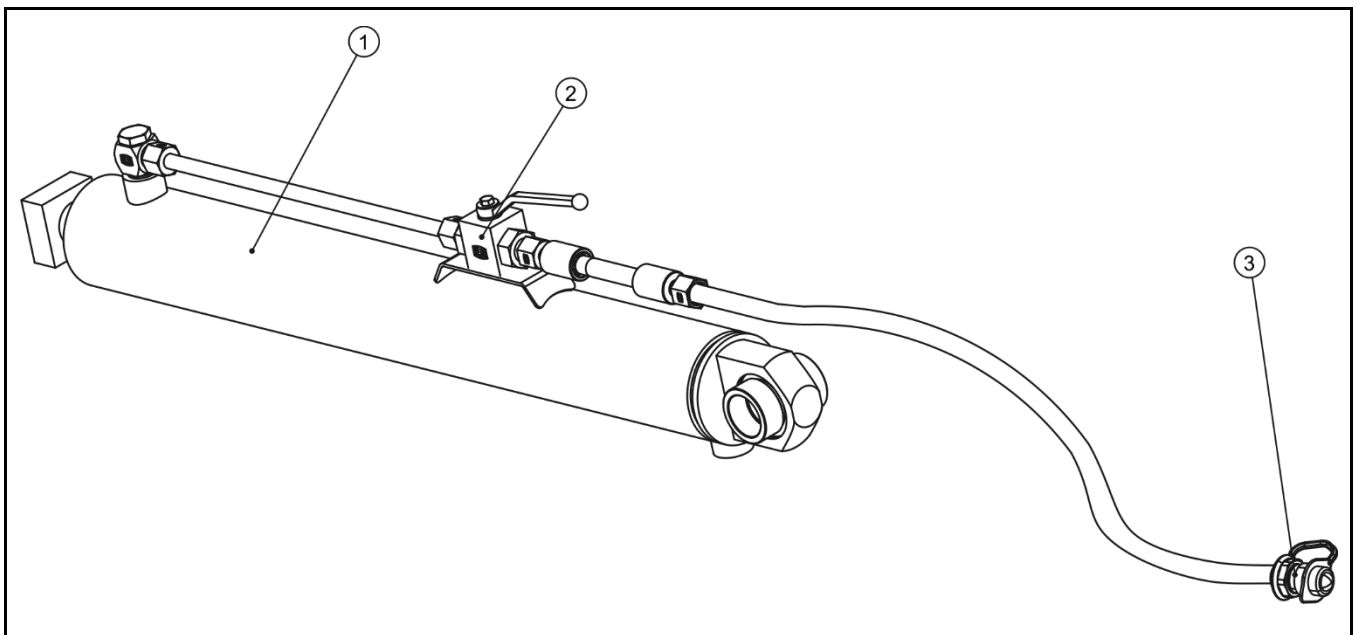

**FIGURE 3.5** Hydraulic system design

(1) hydraulic cylinder, (2) ball valve, (3) quick coupler

### 3.6 CONDITIONING ASSEMBLY (PDF300C)

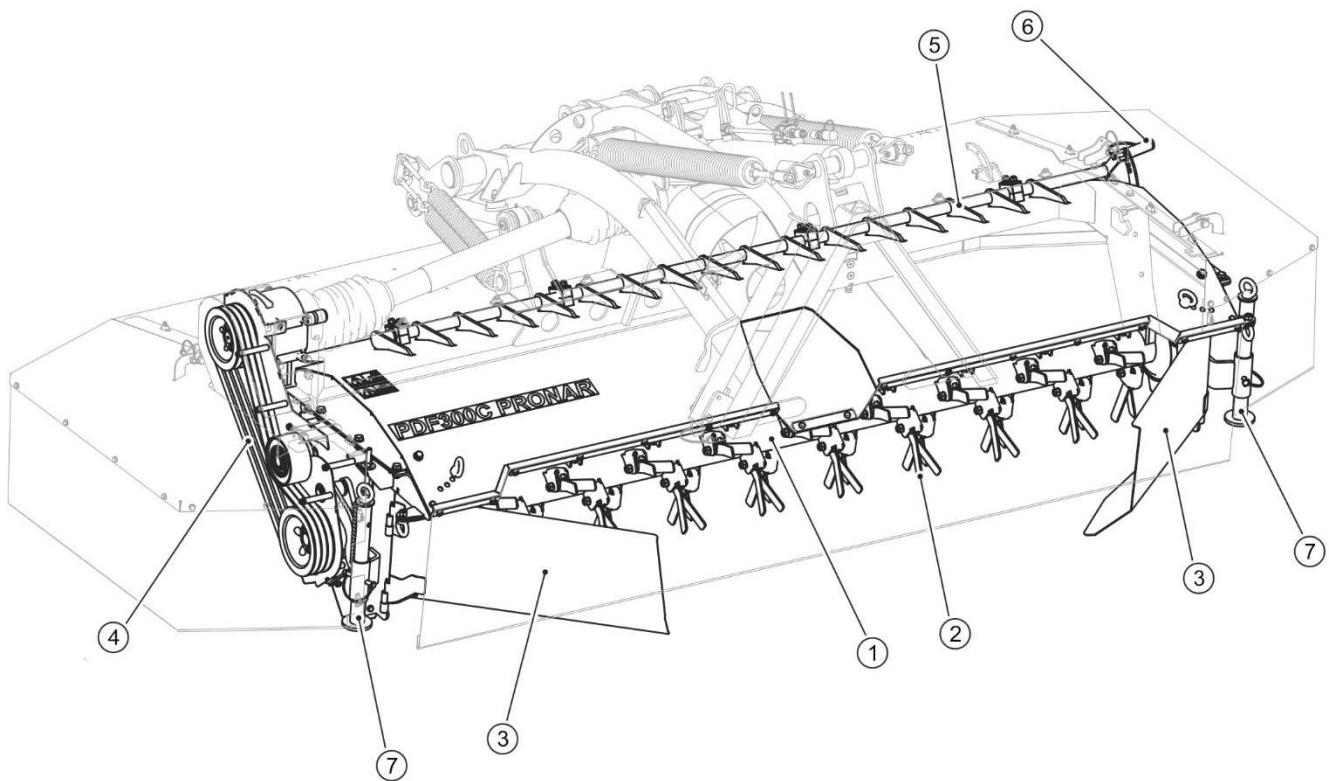

**FIGURE 3.6 Conditioning assembly design**

(1) conditioner shaft; (2) conditioner flail blade; (3) swath guides; (4) belt drive; (5) damping fingers; (6) damping fingers adjustment lever; (7) conditioning assembly supports

PRONAR PDF300C mower conditioning assembly consists of a shaft (1) on which spring tines (2) are fitted. Swath conditioner flail blades intercept material from the cutter bar and toss it over the conditioner shaft (2) to swath guides (3), which form a swath of a specific width depending on the setting. The conditioning intensity can be adjusted using the lever (6), which sets the damping fingers (5) relative to the conditioner shaft so that the material is properly formed and conditioned. The entire conditioning assembly is driven by the intersecting axis gear through belt transmission (4), which in turn is driven by the cutterbar.

*SECTION*

**4**

---

**CORRECT  
USE**

## 4.1 PREPARING FOR WORK

The manufacturer guarantees that the mower is fully operational and has been checked according to quality control procedures and is ready for use. This does not release the user from an obligation to check the machine's condition after delivery and before first use. The machine is delivered to the user completely assembled.

Before connecting to tractor, machine operator must check the technical condition of the mower and prepare it for test start-up. In order to do this:

- the user must carefully read this Operator's Manual and observe all recommendations, understand the design and the principle of machine operation
- check the condition of protective paint coat,
- Inspect mower's individual components for mechanical damage resulting from incorrect transport (dents, piercing, bent or broken components),
- check all the lubrication points, lubricate the machine as needed according to recommendations provided in SECTION 5 "MAINTENANCE",
- check technical condition of the hydraulic system,
- check if the cutting blades, cutter bar, linkage and protective guards are installed correctly,
- check technical condition of hitching system pins and locking cotter pins,
- check level of lubricating oil in angle transmissions and cutterbar.

If all the above actions are completed and if the technical condition of the mower is not a cause of concern then connect it to the tractor according to SECTION 4.3 "*HITCHING TO TRACTOR*". Start the tractor's engine, check all systems and test the mower before beginning work. In order to inspect:

- hitch the mower to tractor (see SECTION 4.3 "*HITCHING TO TRACTOR*")
- set in working position,
- adjust the length of PTO shaft to compatible tractor according to the Operator's Manual of PTO shaft,



- connect PTO shaft to tractor and mower,
- start tractor PTO slowly

**ATTENTION!**

Before connecting the mower to tractor adjust the length of PTO shaft according to the PTO shaft Operator's Manual.

**ATTENTION!**

Before using the mower always check its technical condition. In particular check the technical condition of the cutting unit, linkage, drive system, and integrity of protective guards.

Discs and cutting blades work at high rotation speed and even the smallest damage may cause an increase in vibration, which after a certain time shall result in fractures and cracks.

Leave for several minutes working at low RPM, during which check:

- that there is no knocking or noise in the drive system arising from scraping or grinding of metal elements,
- if the discs on the cutterbar rotates smoothly without any faltering,
- whether there is excessive vibration in the cutting unit,
- synchronised rotation of cutting unit.

The mower's operation at no load should be smooth. Shaking of drive transmission, cutting unit and whole machine is not acceptable, nor is changed noise and vibrations coming from loose nut and bolt connections. After stopping mower, check fastening of cutting blades. Check that gear oil does not leak from reduction gear and cutter bar.

## **DANGER**



**Before using the mower, the user must carefully read this operator's manual.**

**Careless and improper use and operation of the mower, and non-compliance with the recommendations given in this operator's manual is dangerous to your health.**

**The mower must never be used by persons, who are not authorised to drive agricultural tractors, including children and people under the influence of alcohol or other drugs.**

**Non-compliance with the safety rules of this Operator's Manual can be dangerous to the health and life of the operator and others.**

**Before starting the mower, make sure that there are no bystanders in the danger zone.**

If any faults are detected they must be identified and rectified. If a fault cannot be rectified or the repair could void the warranty, please contact retailer for additional clarifications.

## 4.2 CHECKING TECHNICAL CONDITION

When preparing the rotary rake for normal use, check individual elements according to guidelines presented in TABLE (4.1).

**TABLE 4.1 TECHNICAL INSPECTION SCHEDULE**

DESCRIPTION	SERVICE OPERATION	FREQUENCY OF INSPECTIONS
Condition of safety guards	Check technical condition of safety guards, if complete and correctly mounted.	Daily before beginning work
check if cutter bar and lifting arm are correctly installed,	Check if correctly installed	
Operation of hydraulic system	Check the tightness of lines and proper operation of hydraulic cylinder.	
Check the technical condition of cutting blades (PDF300 / PDF300C) and conditioner flail blades (PDF300C)	Visually inspect and if necessary replace according to section „CHECKING AND REPLACING CUTTING KNIVES”	
Check oil level in intersecting axis gears	For details please refer to section "DRIVE SYSTEM OPERATION"	
Check oil level in cutterbar	For details please refer to section "CUTTERBAR OPERATION"	
Check tightness of securing nuts and bolts	Torque values should be according to TABLE (5.4)	Every three months or before the beginning of a season
Lubrication	Lubricate elements according to guidelines presented in section "LUBRICATION".	Accordin g to TABLE 5.3



### ATTENTION!

Do NOT use unreliable mower.

## 4.3 HITCHING TO TRACTOR

The PRONAR PDF300 / PDF300C mower may only be mounted on a tractor fulfilling the requirements contained in TABLE „1.1 AGRICULTURAL TRACTOR'S REQUIREMENTS”.



### ATTENTION!

Before using the mower, the user must carefully read the tractor operator's manual.



### DANGER

When hitching, there must be nobody between the machine and the tractor.  
Exercise caution when hitching the machine.

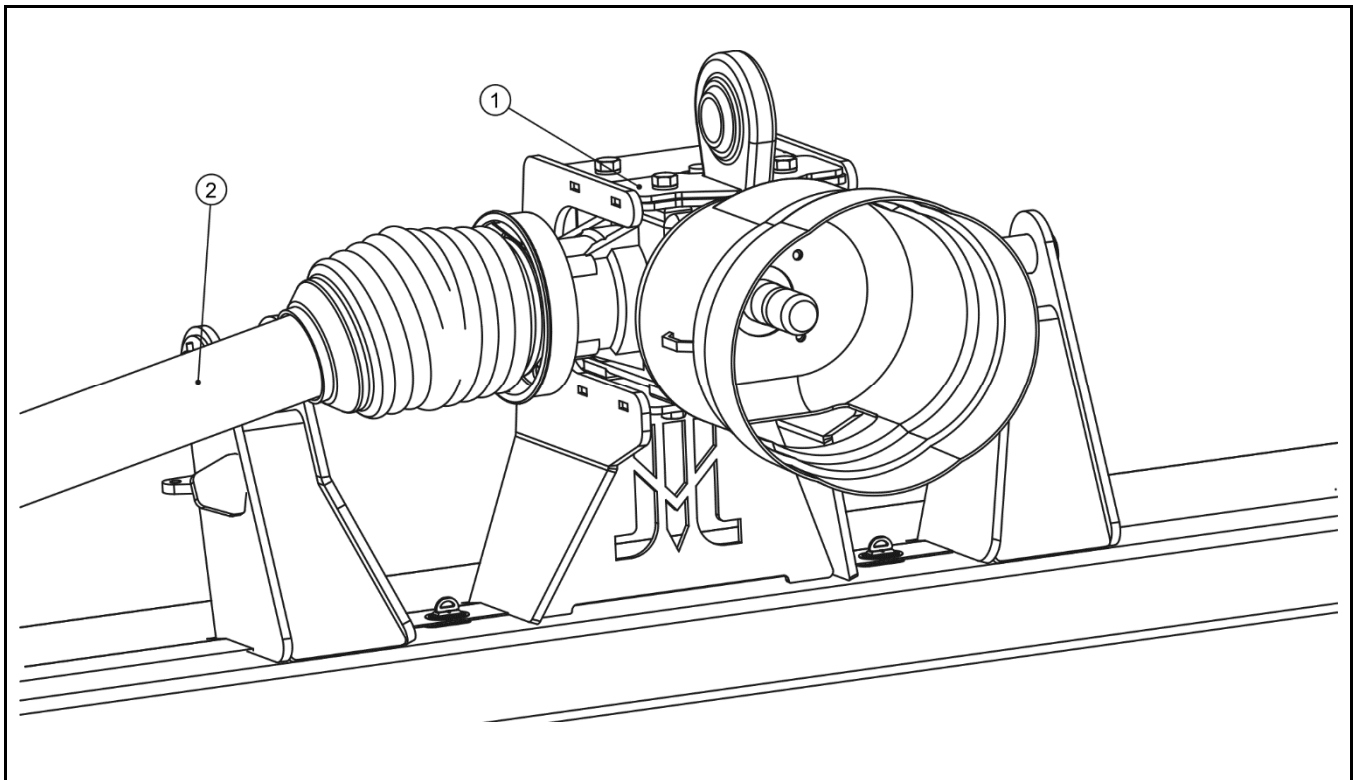
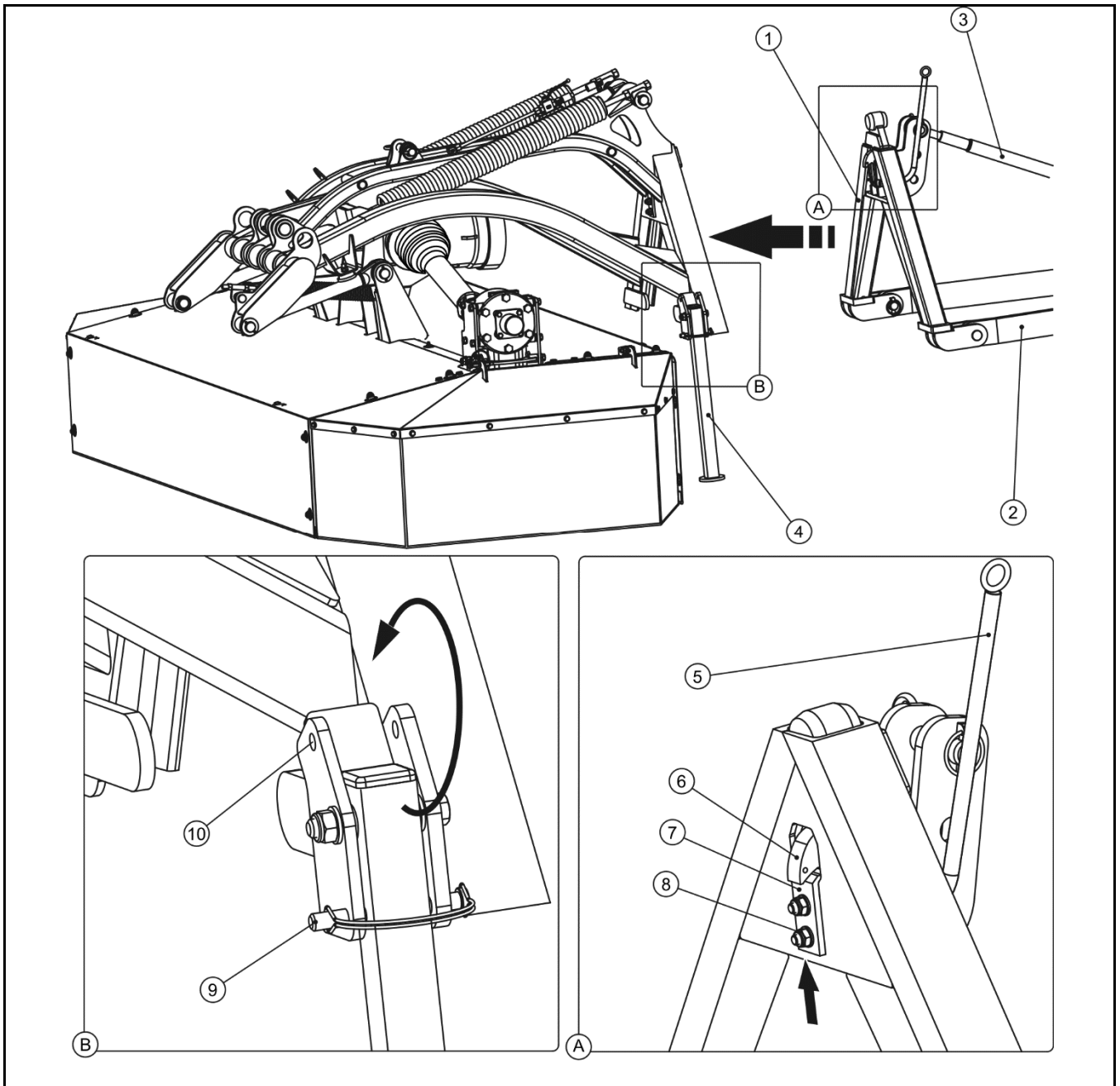

FIGURE 4.1 Position of intersecting axis gear

(1) mower central transmission, (2) PTO shaft

Before hitching the mower to tractor, check that PTO speed of both tractor and the mower are the same. Standard machine is suitable for connection to tractors with PTO shaft turning clockwise when seen from front of tractor. To connect the machine to a tractor with PTO

turning in the other direction, disassemble and turn the mower's intersecting axis gear (1) (FIGURE 4.1) in the centre of the mower by 180°.



**FIGURE 4.2 Hitching to tractor**

(1) triangular hitching system, (2) lower link of tractor's three-point linkage, (3) top link, (4) support leg, (5) catch lever, (6) catch, (7) catch limiter, (8) catch bolt, (9) support pin, (10) pin hole

Once PTO rotation direction is determined and possibly after reversing the direction, in order to attach the mower to tractor, proceed as follows (FIGURE 4.2):

- Attach triangular hitching system (1) to tensions rods (2) of tractor's front three-point linkage,
- Attach top link (3) between the triangular hitching system and tractor's three-point linkage so that triangle is positioned vertically or slightly inclined forward,
- Secure pins of lower links using cotter pins,



### ATTENTION!

Comply with the recommendations relating to linkage and mounting points.

- Drive tractor to mower so that the catch of the triangular hitching system (6) engages. If the connection has too much slack, set catch limiter (7). To this end lower the mower to the surface. Loosen nuts (8) and move catch limiter (7) toward the catch (6) so that it can be released using the lever (5). Tighten nuts (8) bearing in mind that they have to be re-tightened after approximately 8 hours of work.



### DANGER

To hitch the machine to tractor use only genuine pins and safeguards.

If play between the catch (6) and limiter (7) is excessive the mower can get disconnected from tractor during work or transport.

- Connect mower lifting cylinder hydraulic line to a quick coupler in the tractor,



### DANGER

Prior to connecting hydraulic system lines the user must carefully read the tractor operator's manual and observe all recommendations of the Manufacturer.

When connecting the hydraulic conduits to the tractor, make sure that the tractor hydraulic system is not under pressure.

- Lift support leg (4) and insert pin (9) into hole (10) and secure with cotter pin,
- Raise the supports (7) (FIGURE 3.6) of the conditioning assembly (PDF300C) and secure with a cotter pin,

- Set mower in working position. Adjustments can be made using top link (3). The length of the link should be such that the triangular hitching system be set vertically and the distance from the surface to the axis of the bottom fastening for the triangular hitching system pin be approx. 700 mm,
- Install PTO shaft between the machine and tractor. Connect to the mower friction clutch end of the shaft,
- Install relief chains if the bottom links of the tractor's three-point linkage system drop under the machine's weight. Attach upper ends to top link pin. Attach opposite ends to lower links of tractor's three-point linkage.

## 4.4 TRANSPORTING THE MACHINE

When driving on public or private roads, respect the road traffic regulations, exercise caution and prudence.

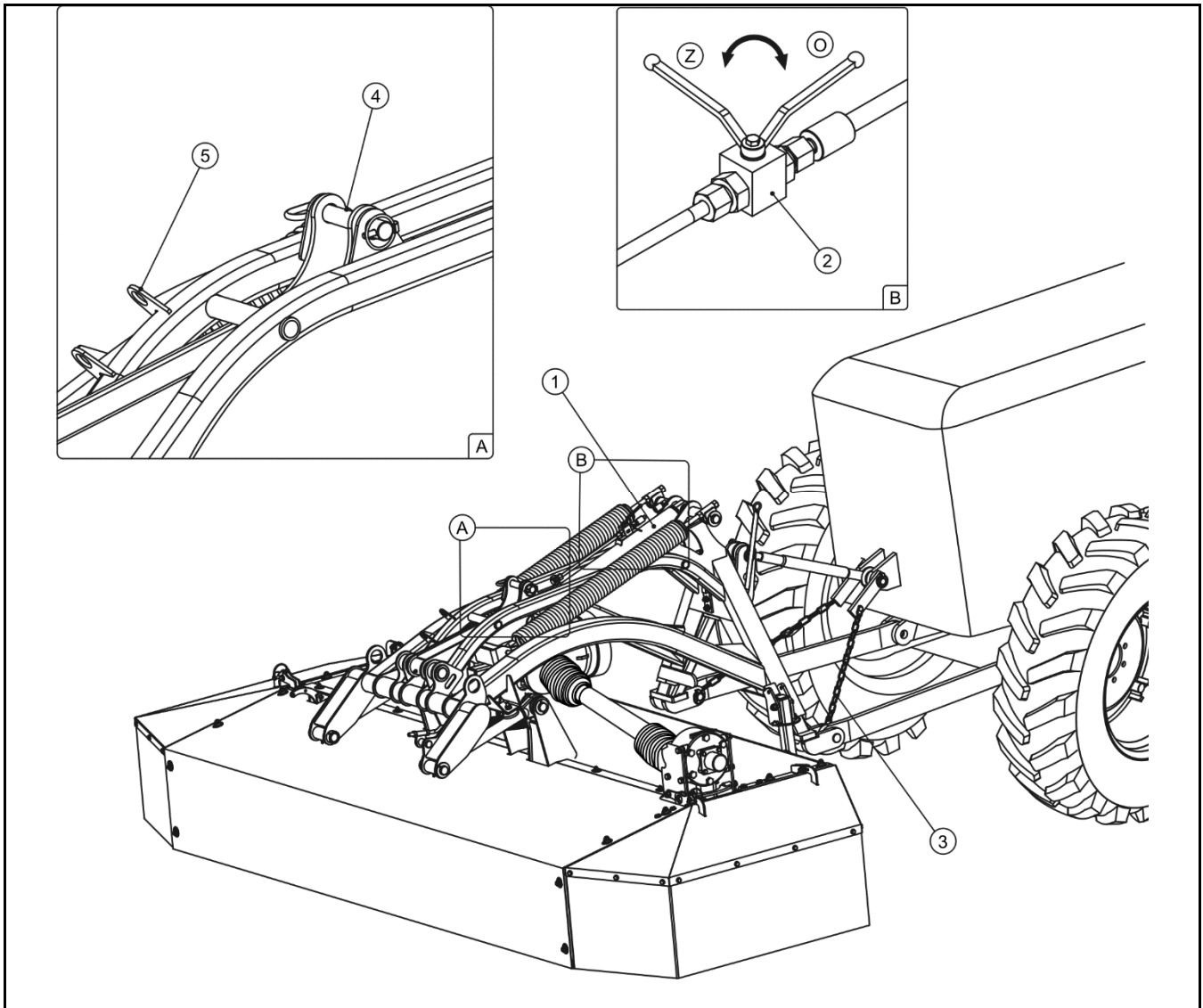

**FIGURE 4.3 Locking the mower in the transport position**

(1) hydraulic cylinder, (2) cut-off valve, (3) relief chains, (4) locking pins, (5) pin fastening eye

To prepare mower for transport (travel on roads) perform the following actions on the tractor:

- connect mower cylinder hydraulic line to a quick coupler of tractor's hydraulic system,
- lift the main frame with the cutting unit by means of the mower's hydraulic cylinder (1) (FIGURE 4.3) by operating the tractor's external hydraulic system lever.



- secure mower against falling by closing cut-off valve (2) located on the hydraulic cylinder. Set valve in position (Z).

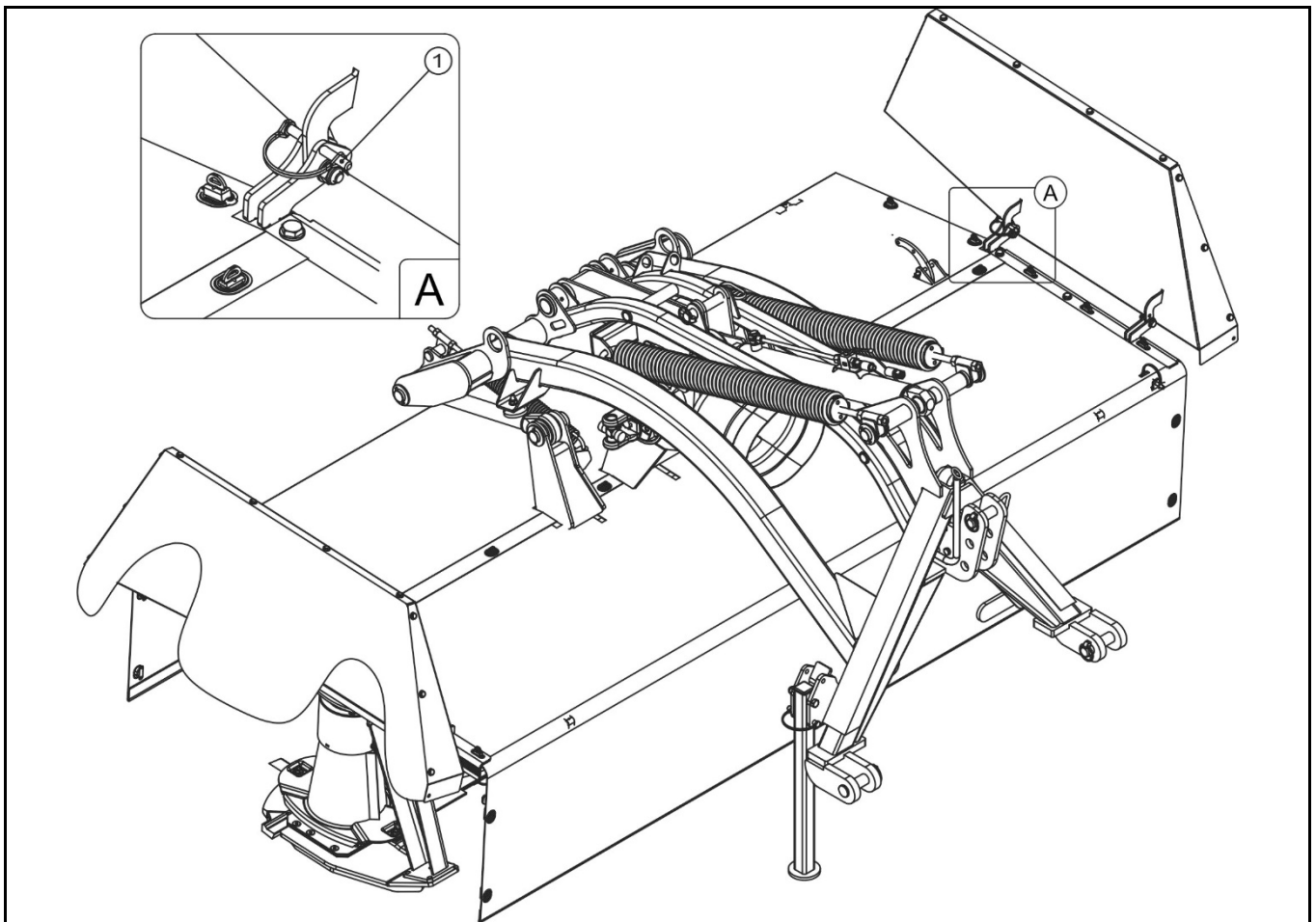

FIGURE 4.4 **Raising guards to the transport position**

(1) – securing pins

- raise mower side shields and secure with pins (1) (FIGURE 4.4).
- lift mower on tractor lower linkage arms using three point linkage.
- secure with relief chains (3) (FIGURE 4.3) if the bottom links of the tractor's three-point linkage system drop under the machine's weight.
- lock in transport position using securing pin (4) suitably secure using a cotter pin.
- Raise the mower on tractors links to a height allowing safe transport making sure that driver's visibility is not limited.

Listed below are the key guidelines for driving the tractor and mower combination.

- Transport on public roads and outside fields must always take place with raised machine.
- Before moving off make sure that there are no bystanders, especially children, near the mower or the tractor. Take care that the driver has sufficient visibility.
- Make sure that the mower is properly attached to the tractor, and that the PTO shaft is correctly secured.
- Permissible design speed and maximum speed allowed by road traffic law must not be exceeded. Travel speed should be adapted to the current road conditions.

**ATTENTION!**

Do NOT travel with machine which has an unreliable brake, lighting or signalling system.

- Speed must be sufficiently reduced before making a turn or driving on an uneven road or a slope.
- Monitor mower's behaviour when travelling on an uneven terrain, and adjust driving speed to road conditions, slow down early enough when turning.

**ATTENTION!**

Before you start driving the tractor with the mower in the transport position, check if:

- pins connecting the mower and tractor are properly secured,
- the mower is locked correctly with the securing pin (4) (FIGURE 4.3).

Do NOT transport the mower with the cut-off valve (2) of the cylinder in the open position (O) (FIGURE 4.3) .

## 4.5 SETTING AND MOWING

### 4.5.1 SETTING THE MOWER INTO THE OPERATING POSITION AND ADJUSTING THE CUTTING HEIGHT

To work with the PDF300 / PDF300C mower first set it appropriately.

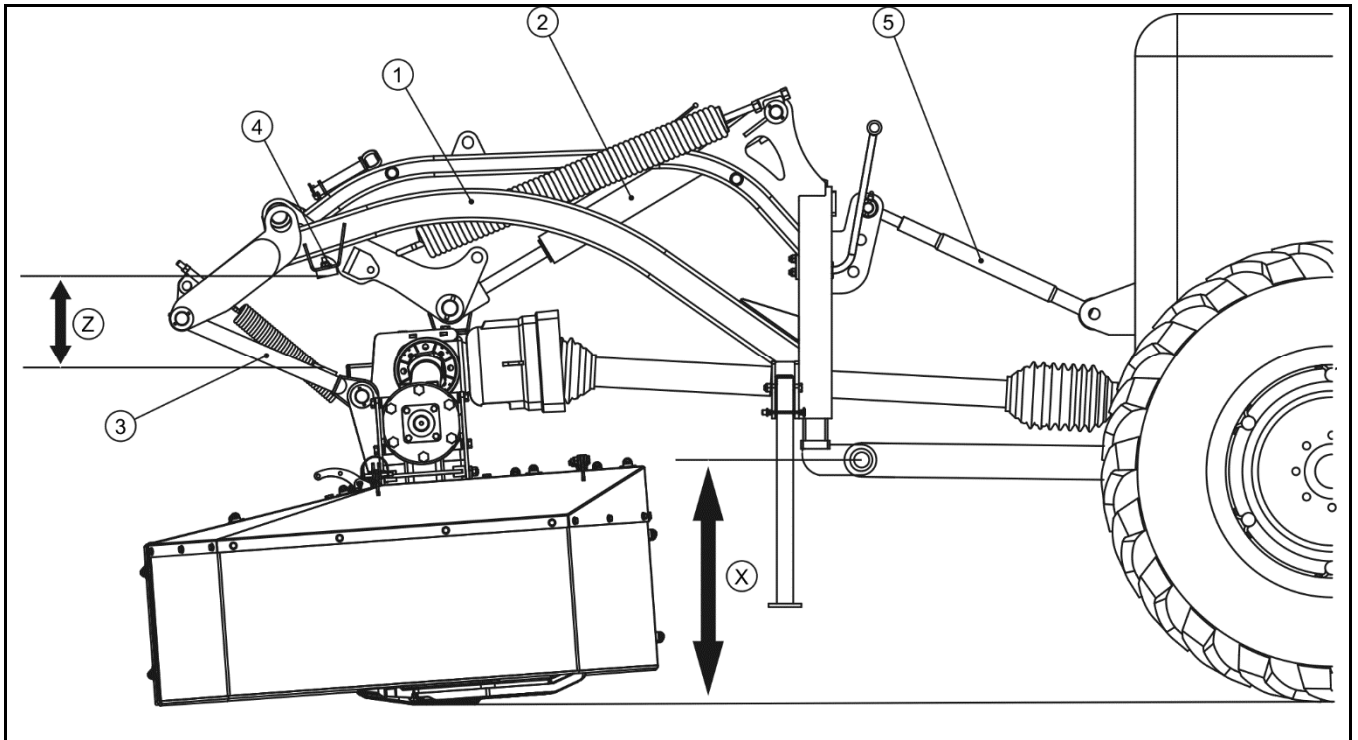

FIGURE 4.5 **Mower base position**

(1) linkage frame, (2) hydraulic cylinder, (3) link, (4) rubber fender, (5) top link, (Z), (X) recommended distance to base position setting

The machine cutting unit is capable of moving up and down in relation to the linkage frame. Such a solution enables the cutting unit to respond to unevenness of the mown field, when the linkage frame (1) moves according to the movements of the tractor. For the mower to work optimally set it to the base position (FIGURE 4.5) recommended by the Manufacturer. In order to set it:

- lower the machine to the ground,
- set tractor lower three-point linkage links at a height (X) of approximately 700mm (adjust the length of relief chains),
- set the mowing height by shortening or lengthening the top link (5).

- Check distance (Z) between the rubber fender (4) and bumper (3) mounted on the link, which must be within the range 200 - 250mm. This distance is necessary to ensure correct surface tracking by the mower during work.

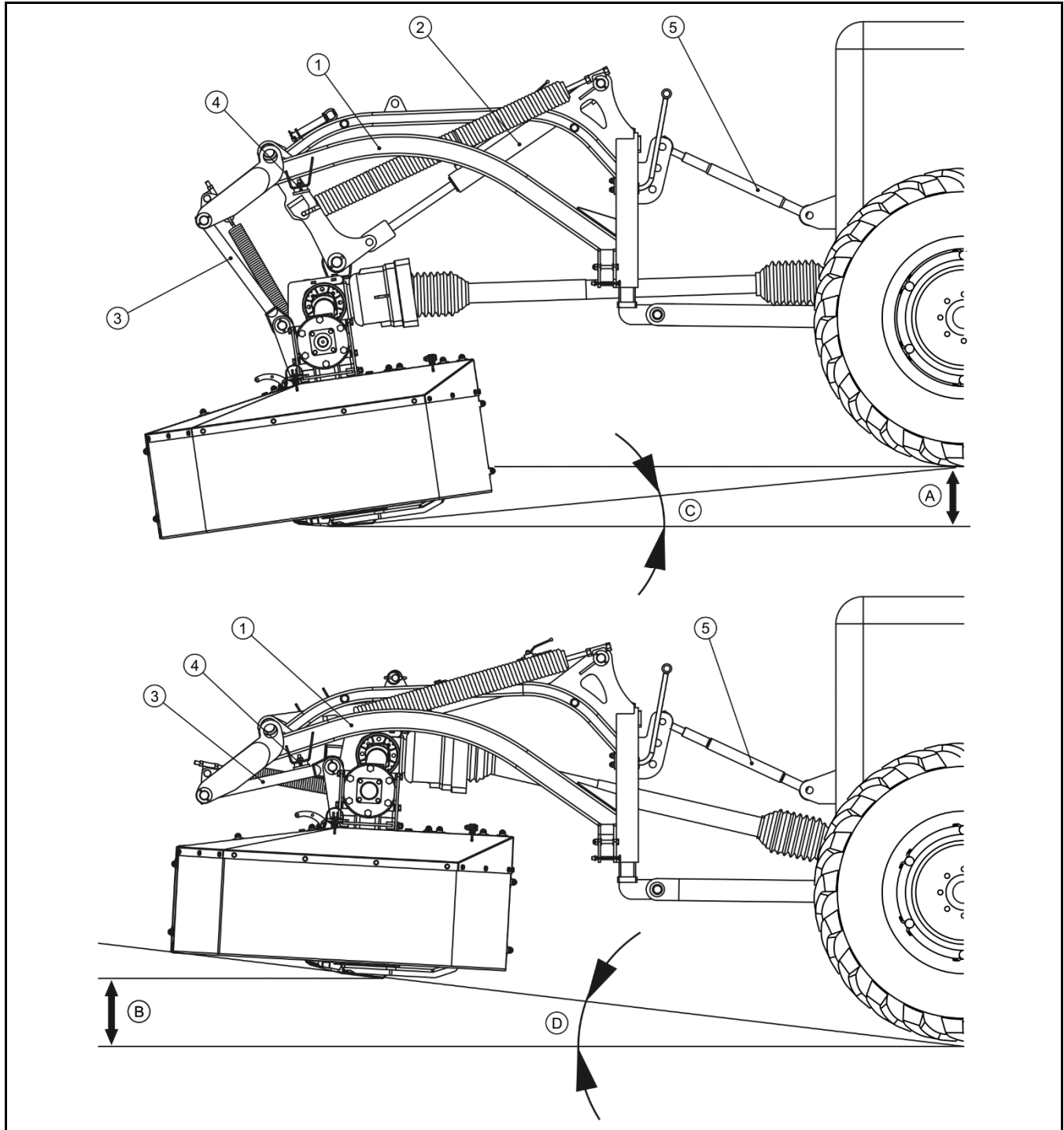

**FIGURE 4.6 Front mower working positions**

(1) linkage frame, (2) hydraulic cylinder, (3) link, (4) rubber fender, (5) top link, (A), (B) cutting unit displacement, (C), (D) cutter bar tipping angle

If terrain in front of mower is inclined downward then the cutting unit moves downward in relation to the frame (1) (FIGURE 4.6). This motion causes the cutter bar to turn forward maintaining the same height of stubble. When tracking terrain, the cutter bar can be set at a maximal angle of  $10^\circ$  (C) to the ground.

If the terrain in front of the machine is inclined upward, the cutting unit moves upward until its rubber fender (4) rests on link bumper (3). During this motion cutter bar turns back maintaining the same stubble height and reducing the risk of blades coming into contact with the ground. Cutter bar tipping angle in relation to the ground can reach a maximum of  $8^\circ$  (D).

In certain conditions it may be necessary to increase or reduce the cutting height. Changes of setting are made by shortening or lengthening the top link (5). Lengthening top link reduces the cutting height and shortening increases the cutting height. When adjusting cutting height it may be necessary to set the top link to a different position in the triangular hitching system.

The cutting unit can be moved within range of 510 mm vertically. By 240 mm (A) downward and 270 mm (B) upward from the base position. Hydraulic cylinder (2) limits downward motion, while hydraulic cylinder (4) sets upper limit.

#### 4.5.2 ADJUSTMENT OF CUTTER BAR PRESSURE

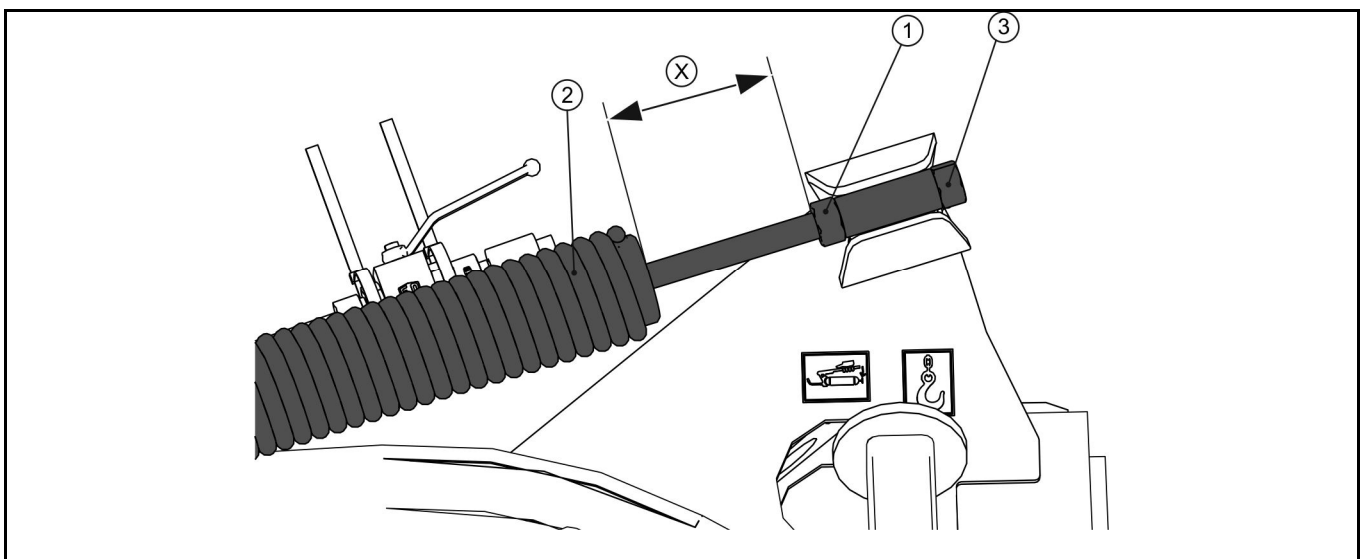

FIGURE 4.7 **Adjustment of cutter bar pressure**

(1) counter nut, (2) stay spring, (3) adjustment bolt

In order to protect the stubble during cutting and reduce partial wear on slide skates of the cutting unit and also to ensure good ground surface tracking it is necessary to adjust the

pressure of the cutterbar on the surface appropriately (FIGURE 4.7). The stay springs (2) are for this purpose. The pressure must be suitable to the ground conditions, the means of movement, type of surface and type of forage mown.

The loading is adjusted by changing the tension of both springs (2).

- Loosen counter nut (1),
- turn adjustment bolt (3) so that spring tension is adjusted,
  - turning the bolt clockwise increases spring tension and reduces cutter bar pressure on the ground (distance X is reduced).
  - turning the bolt anticlockwise reduces spring tension and increases cutter bar pressure on the ground (distance X is increased),
- After achieving required tension, tighten counter nut (1).



### **ATTENTION!**

**Machine loading is set in a factory so that pressure on the soil is suited to work in normal conditions.**

### **4.5.3 SETTING THE SWATH WIDTH IN PDF300 MOWER**

Adjust the swath width depending on the density and length of the crop. With dense and long crops the swath should be wide, while with short crops the swath width should be reduced.

Two swath guides installed on the cutting unit's support frame are used to adjust the swath width.

You may adjust the swath width smoothly within 1,200 ÷ 2,000 mm by adjusting the two swath guides as appropriate.

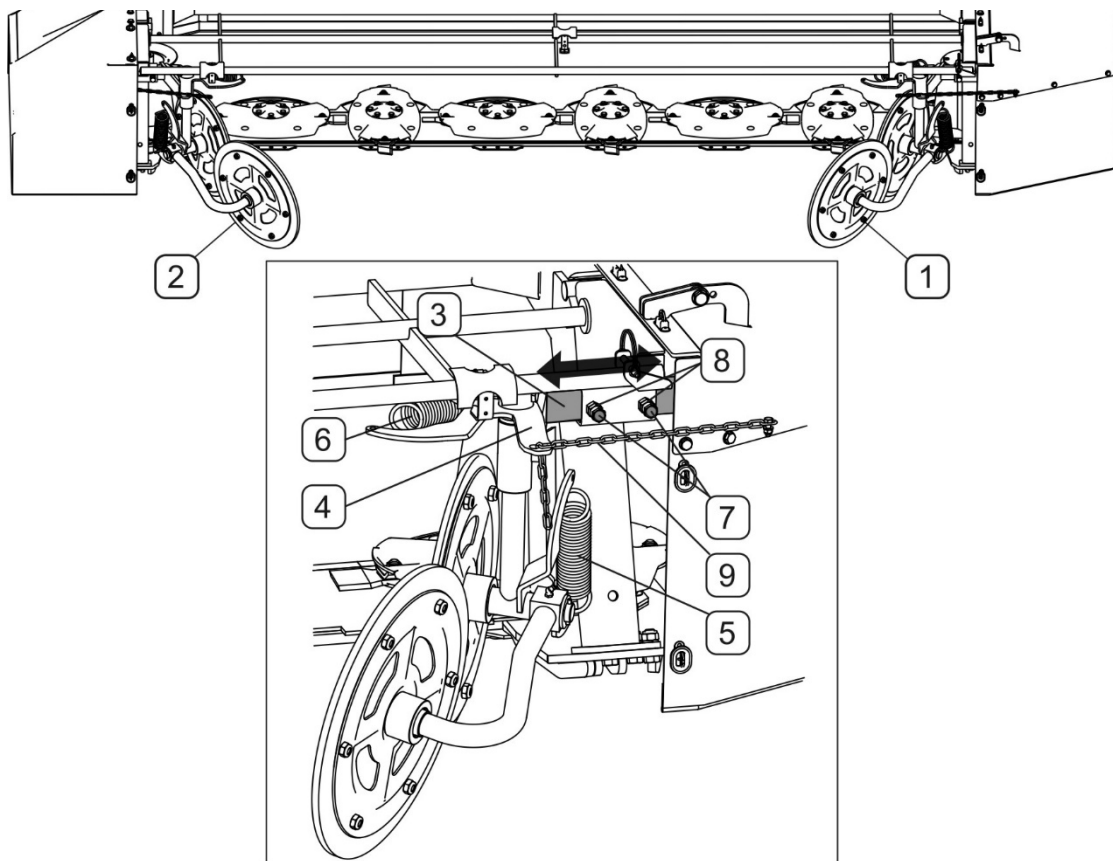

FIGURE 4.8 **PDF300 swath guide adjustment**

(1)- right swath guide unit; (2)- left swath guide unit; (3)- guide arm; (4)- head; (5)- guide unit cushion spring for the vertical plane; (6)- guide unit cushion spring for the horizontal plane; (7)- arm press bolts; (8)- counter nuts; (9)- limiting chain.

To adjust the entire swath guide unit in the horizontal plane:

- loosen counter nuts (8) and bolts (7) (FIGURE 4.8),
- Move arm (3) as required, tighten bolts (7) and secure with counter nuts (8),

Besides the adjustment of the guide unit operating width you may also adjust the dampening scope of the spring (6) in the horizontal plane, which also affects the swath width. To this end, adjust the length of the limiting chain (9) as appropriate by attaching it in the head (4) fastening hole at the right length (4).

Proceed the same way with the opposite swath guide.

#### 4.5.4 SETTING THE SWATH WIDTH IN PDF300C MOWER

Two swath guides installed on the conditioner unit support frame are used to adjust the swath width.

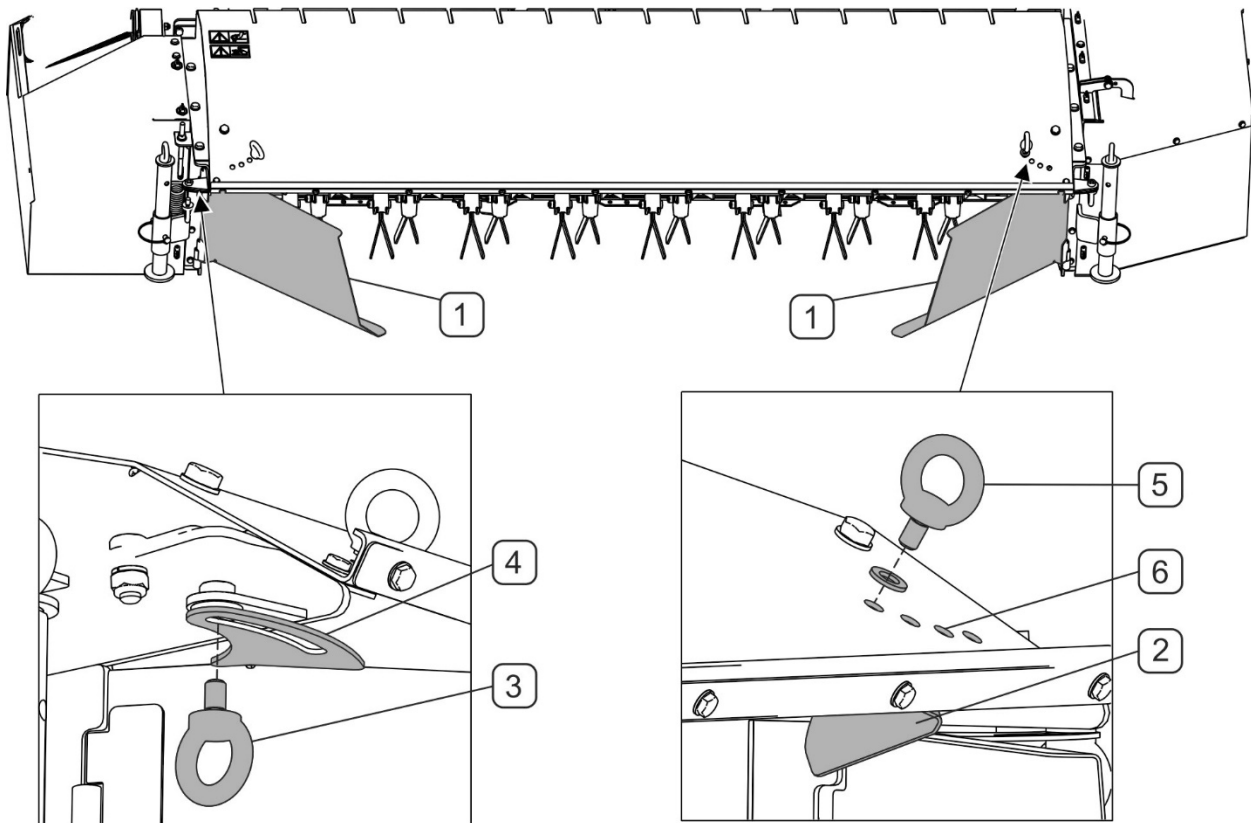

FIGURE 4.9 PDF300C swath guide adjustment.

(1) - swath guides, (2) - swath blade, (3) - swath guide adjustment bolt, (4) - swath guide bracket with a kidney slot; (5) - swath blade adjustment bolt, (6) - swath blade adjustment openings.

You may adjust the swath width smoothly within 1,500 ÷ 2,300 mm by adjusting the two swath guides (1) as appropriate. To adjust swath guide position:

- loosen the adjusting screw (3) in the kidney slot of the bracket (4) at the swath guide (1),
- rotate swath guide (1) setting the appropriate swath width, and tighten the adjusting bolt (3) in the kidney slot,,

Adjust the swath blade (2) to match the setting of the swath guide (1) so that the stream of the crops mown be guided to the swath guide. In order to do this:



- unscrew the adjusting screw (5),
- set swath blade (2) as required so that its opening is in line with the opening (6) in conditioner body
- tighten the adjusting screw (5) in the selected hole (6).

Proceed the same way with the opposite swath guide and swath blade.

#### **4.5.5 SETTING THE SWATH CONDITIONING INTENSITY IN THE PDF300C MOWER**

Depending on the type and density of the mown material, you can set the intensity of swath conditioning (FIGURE 4.10). This is done by the lever (1) on the support frame of the conditioning assembly connected to the damping fingers. The damping finger must be adjusted so that the mown material does not collect between the cutterbar and conditioning shaft.

To adjust swath conditioning intensity:

- release and remove the securing cotter pin (2),
- move the adjustment lever (1) down to achieve a greater mown material conditioning intensity (MAX) or up to reduce the conditioning intensity;
- adjust the lever so that the hole in the lever is in line with a hole in the bracket;
- insert cotter pin (2) in the hole and secure it.

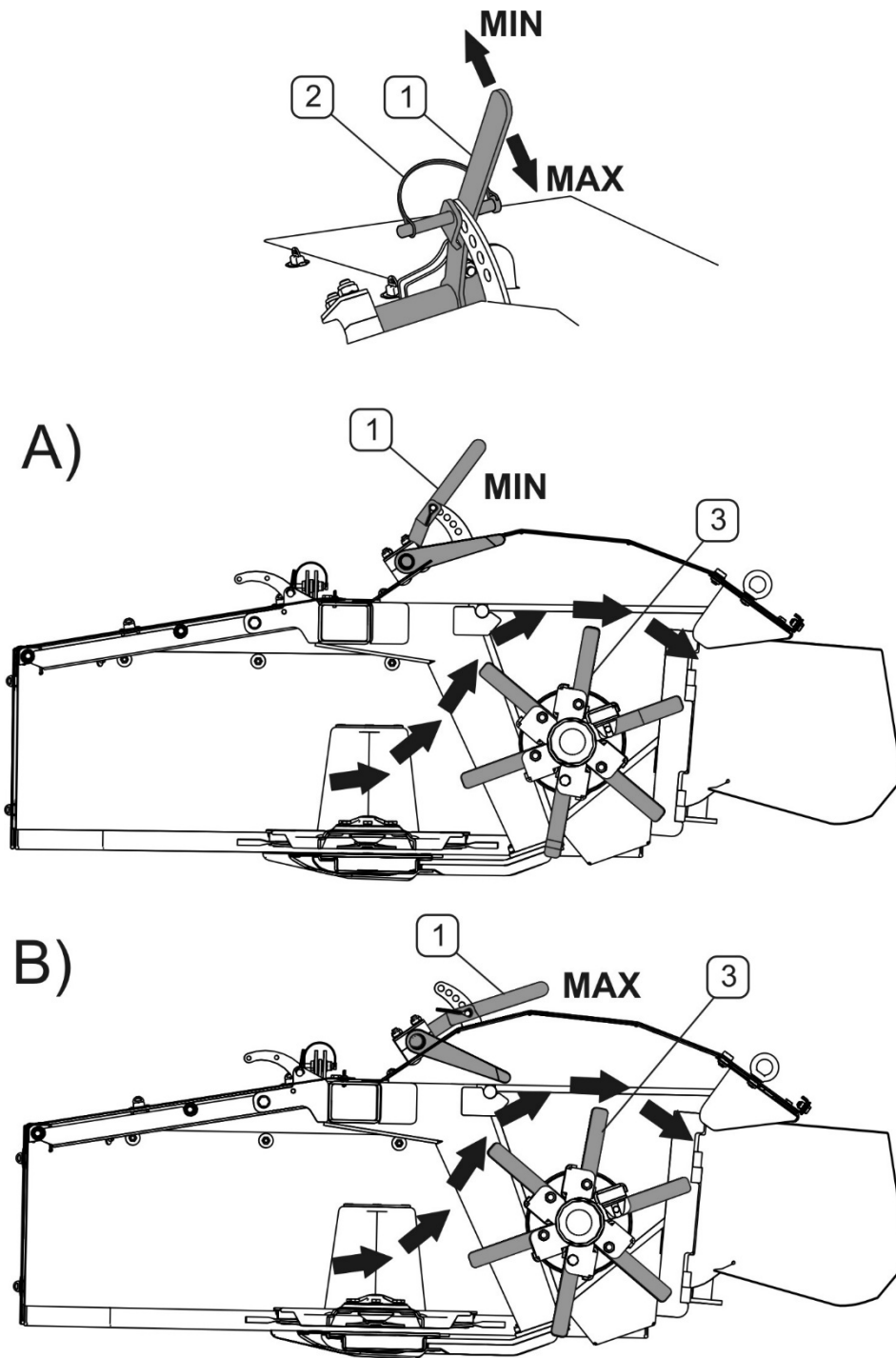

FIGURE 4.10 PDF300C swath conditioner adjustment.

A- minimum swath conditioning intensity setting; B- maximum swath conditioning intensity setting; (1) - swath conditioner adjustment lever, (2) - cotter pin, (3) - swath conditioner flail blades.

### 4.5.6 MOWING

#### **DANGER**



The mower may only be started when all guards are in place and the cutting unit is set in working position.

Before engaging drive to PTO shaft make sure that there are no bystanders, especially children, near the mower.

Other persons should be at a safe distance from the mower during work because of the danger that objects may be thrown (stones, branches from beneath rotating disks).

After reaching the field edge, first set the mower from transport position into working position. In order to do this:

- Using three-point linkage lower cutting unit to the ground,
- set the cut-off valve (2) to position (O), and removing the locking pin (4) put it into the linkage frame lug (5) (FIGURE 4.3),
- Set the mower hydraulic cylinder control lever in floating position,
- Using tractor three-point linkage raise the mower to set it in cutting position – FIGURE 4.5).

After setting mower in working position, observe the following procedure:

- at low engine RPM connect PTO drive,
- gradually increase RPM until reaching 1000 rpm for PTO,
- engage appropriate tractor gear and drive into standing crop.

During starting the cutting unit generates considerable noise. Noise is reduced when mower is driven into standing crop.

#### **HIGH NOISE LEVEL WARNING**



Depending on the working conditions, the tractor with the machine may generate noise exceeding the level of 85dB at the driver position. In such conditions the driver should apply individual protection (protective ear guards).

In order to reduce the level of noise during work the tractor cab window and door should be closed.

cutting speed should be adjusted to the existing conditions that is the density of the crop, and the type of ground surface, on which one is cutting. The driver must always have the tractor

under control and avoid unevenness and foreign bodies in front of the tractor and machine. On hilly terrain the working speed should be reduced and the driver must pay attention to movements of the machine in relation to the ground surface.

Mowing speed must be reduced if:

- mown ground is uneven,
- crop is laid, or very tall and dense,
- there is a great risk of running into foreign bodies e.g. stones, branches and heaps of soil.

Be especially careful when mowing along ditches, furrows and slopes.

### **ATTENTION!**



If the machine is in the working position and cuts, the single acting cylinder for lifting the cutting unit must always be set in floating position so that the cutting unit may move freely tracking the ground contours optimally.

On uneven ground there is a risk of the machine colliding with mounds of soil or foreign bodies and the driver must minimise the risk of damaging the machine.

During crossing over swaths with the mower and during turning the PDF300 mower cutting unit must first be raised with the aid of the lifting cylinder and the number of rotations must be reduced. Travel speed must be reduced.

If during cutting the overload release clutch of the drive shaft is activated, disconnect PTO drive in tractor and check what caused the overload. The overload clutch may be activated because of too low rotation speed of cutting unit.

### **ATTENTION!**



Do NOT operate mower while reversing. The machine design does not allow reversing with the machine in working position.

Reversing the PDF300 mower is impossible, unless the cutting unit is raised from the ground with mower hydraulic cylinder and the front lifter.

During cutting always maintain constant RPM speed of 1000 rpm for optimum cutting performance. If RPM speed falls the drive loading increases significantly and it may occur at the friction clutch would be activated to protect the system. In such a situation always disconnect the drive and check the cause of the overloading.

Give special attention to sudden movements and impacts in the cutting unit. After a strong impact was an obstacle always check the machine in case of possible damage. Damaged elements must be replaced.

**DANGER**

Along banks, ditches and furrows always be especially careful and reduce speed because of the possibility encountering foreign bodies and because of soil differences on the edges of banks and furrows. Not reducing speed may cause the soil to slip and the tractor and machine to overturn.

## 4.6 DISCONNECTING FROM TRACTOR

In order to disconnect the mower from the tractor proceed as follows:

- Release mower support foot (FIGURE 4.2) and insert locking pin to secure it,
- lower mower using three point linkage to rest position,
- switch off tractor engine and remove key from ignition,
- disconnect hydraulic line,

**DANGER**

Reduce pressure prior to disconnecting the hydraulic system.

- disconnect the PTO shaft from the tractor's PTO,
- disconnect the mower from the triangular hitching system and drive the tractor away from the mower,
- dismantle the triangular hitching system from the front three-point linkage system of the tractor.

**DANGER**

Before disconnecting tractor from mower check that the machine is protected against falling over.

During disconnection there must be nobody between the mower and the tractor.

Before lowering or raising mower on three point linkage make certain that nobody is near the machine and that nobody is operating it.

Once disconnected from the tractor, the mower should rest on the support leg and cutter bar.

**DANGER**

When disconnecting the mower from the tractor, **NEVER** leave the triangular hitching system connected to the mower. There is a danger that the triangular hitching system may get disconnected from the mower accidentally and cause personal injuries.

## 4.7 LIGHTING INSTALLATION AND ADDITIONAL MARKING (OPTIONAL)

### 4.7.1 CONSTRUCTION

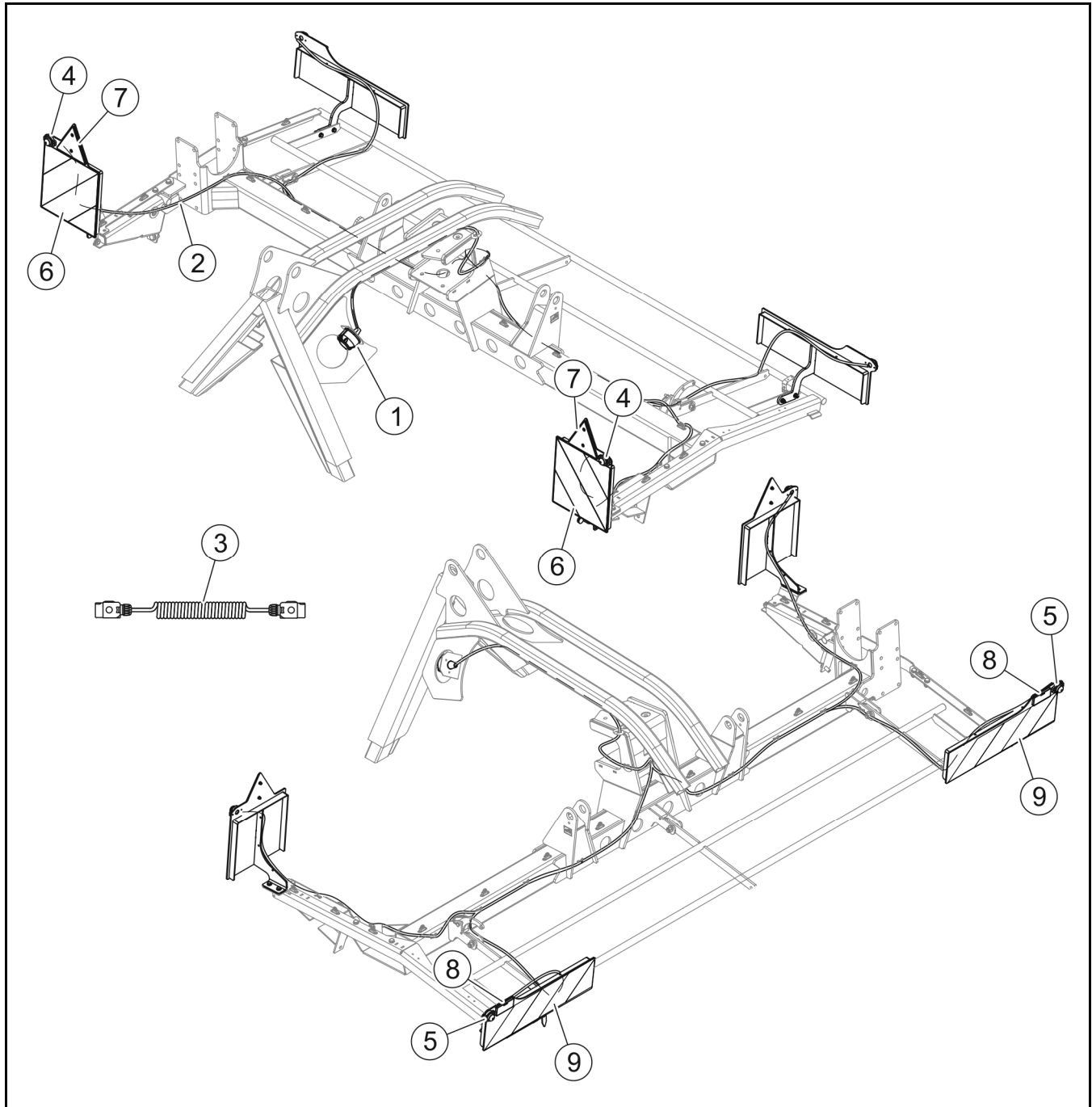

FIGURE 4.11 Lighting installation and additional marking (optional).

(1) 7-pin electric socket, (2) central harness, (3) 7-pin 12V spiral cable, (4) rear position lamps, (5) front position lamps, (6) contour marking, (7) reflective triangle DOB-31 (option), (8) DOB-35 white rectangular reflector, (9) warning film.

### 4.7.2 USAGE AND MAINTENANCE

The power supply to the lighting system of the machine requires the electrical installation of a tractor with a voltage of 12V with a 7-pin electrical outlet.



#### CAUTION

Driving with defective lighting installations is prohibited. Damaged lamps should be replaced immediately before driving off. Lost or damaged reflectors should be replaced with new ones.

Before travelling, make sure that all lamps and reflectors are clean.

Works related to the repair, replacement or regeneration of electrical installation components should be entrusted to specialized workshops that have appropriate technologies and qualifications to perform this type of work.

Your duties include only technical inspection of the electrical installation and reflectors.

#### The scope of service activities

1. Connect the lighting system of the machine to the tractor with a suitable electrical outlet.



#### CAUTION

If the tractor does not have the correct sockets or if the sockets are of a different type, have them installed by qualified personnel.

2. Check the completeness, technical condition and correct functioning of the machine lighting.
3. Check the tractor connection socket and the cable plug on the machine.



#### CAUTION

A damaged body of the socket or plug of the electric cord qualifies for replacement.

4. Check the the wiring harness for damage (rubbed insulation, wire break, etc.).

Before travelling on a public road, make sure that the tractor has a reflective warning triangle.





*SECTION*

**5**

---

**MAINTENANCE**

## 5.1 CHECKING AND REPLACING CUTTING BLADES

### 5.1.1 INSPECTION AND REPLACEMENT OF THE CUTTER BAR BLADES



**DANGER**

During inspection and replacement of blades, switch off tractor engine and remove the key from the ignition and disengage PTO shaft. Cutter bar must rest on the ground.

Use only CE certified blades meeting the requirements of ISO 5718 standard.

Inspections of flail blades must be carried out regularly. Visual inspection involves checking of the knife's blade and mounting. blades should be worn down uniformly. If knife's blade is worn down naturally it can be reversed and reinstalled on the cutting disk (this applies to double edged blades).

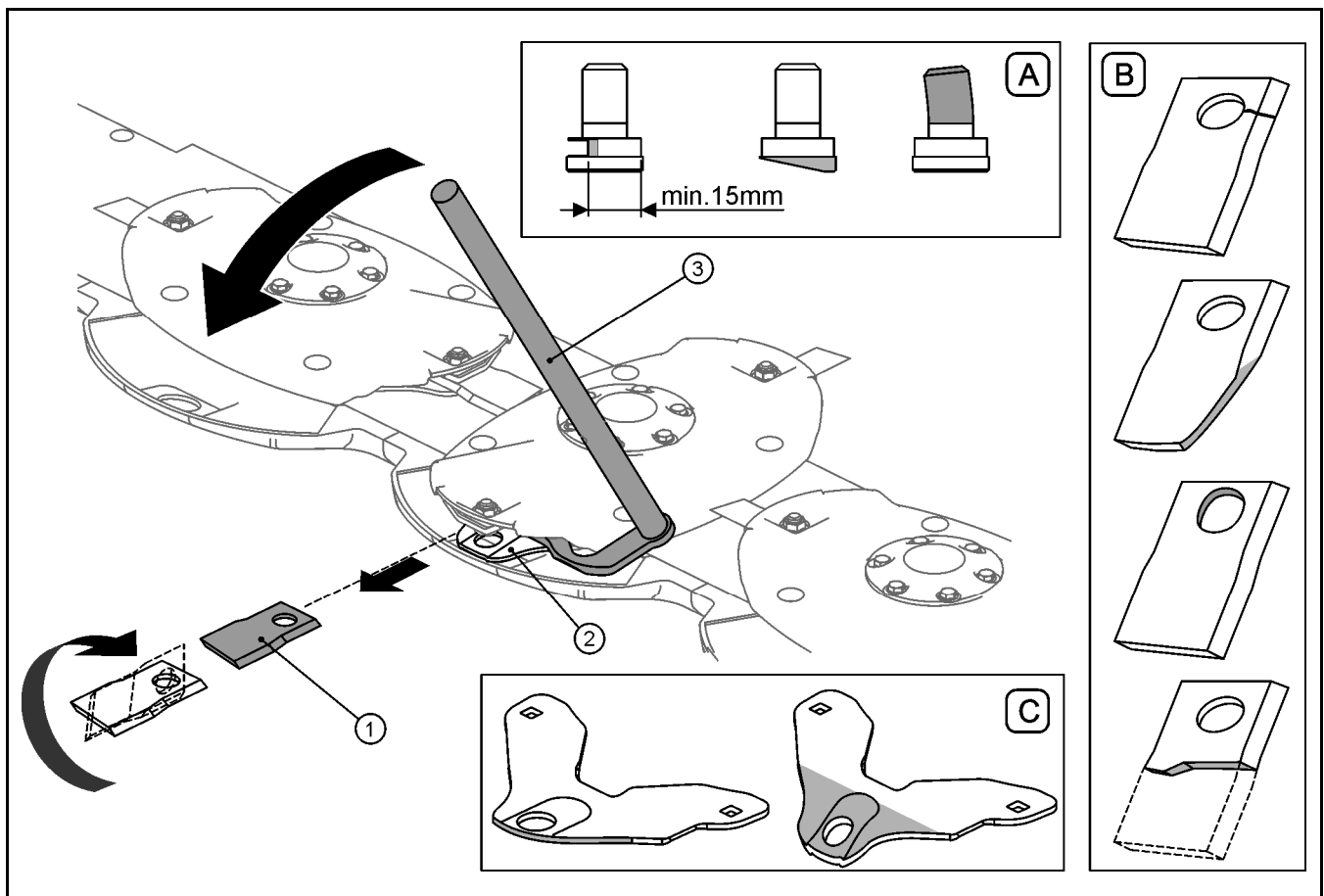

**FIGURE 5.1 Replacement of the cutter bar blades**

(1) cutting knife; (2) knife holder; (3) knife changing key; (A) arbor damage example; (B) knife damage example; (C) knife holder damage example

A bent or damaged knife must be replaced with a new one. Cutting blades must be replaced in pairs in order to maintain the balance of the cutting disc. Before proceeding to replace the blades, clean the residue of mown material from the cutter bar.

Use key to change parts (3) placing it between knife holder (2) and cutting disc, next press on key (3) till the moment that it is possible to take out the (1). When changing blades check the condition of the arbor securing the knife to the cutting disk and also the knife holder. An excessively worn or damaged arbor or knife holder should be replaced with a new part. Tighten arbor nuts with torque of 120 Nm.



### ATTENTION

Missing knife or its fragment will cause imbalance and excessive cutting disk vibration and may damage the cutter bar.



### TIP

Damaged or worn blades must be changed in pairs in order to maintain balance of cutting disc.

**TABLE 5.1 CUTTING KNIFE CHARACTERISTICS**

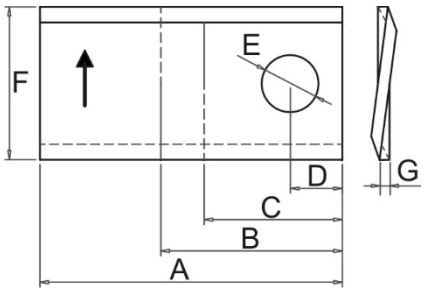
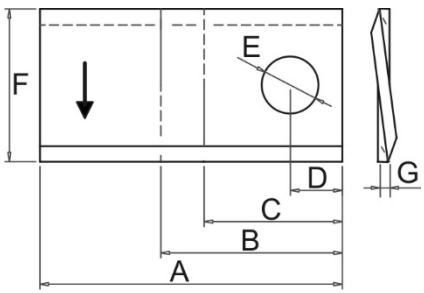
MARKING KNIFE	FIGURE	DIMENSIONS [mm]						
		A	B	C	D	E	F	G
120/49/4 P (RIGHT)		120	57	42	20	21	49	4
120/49/4 L (LEFT)		120	57	42	20	21	49	4

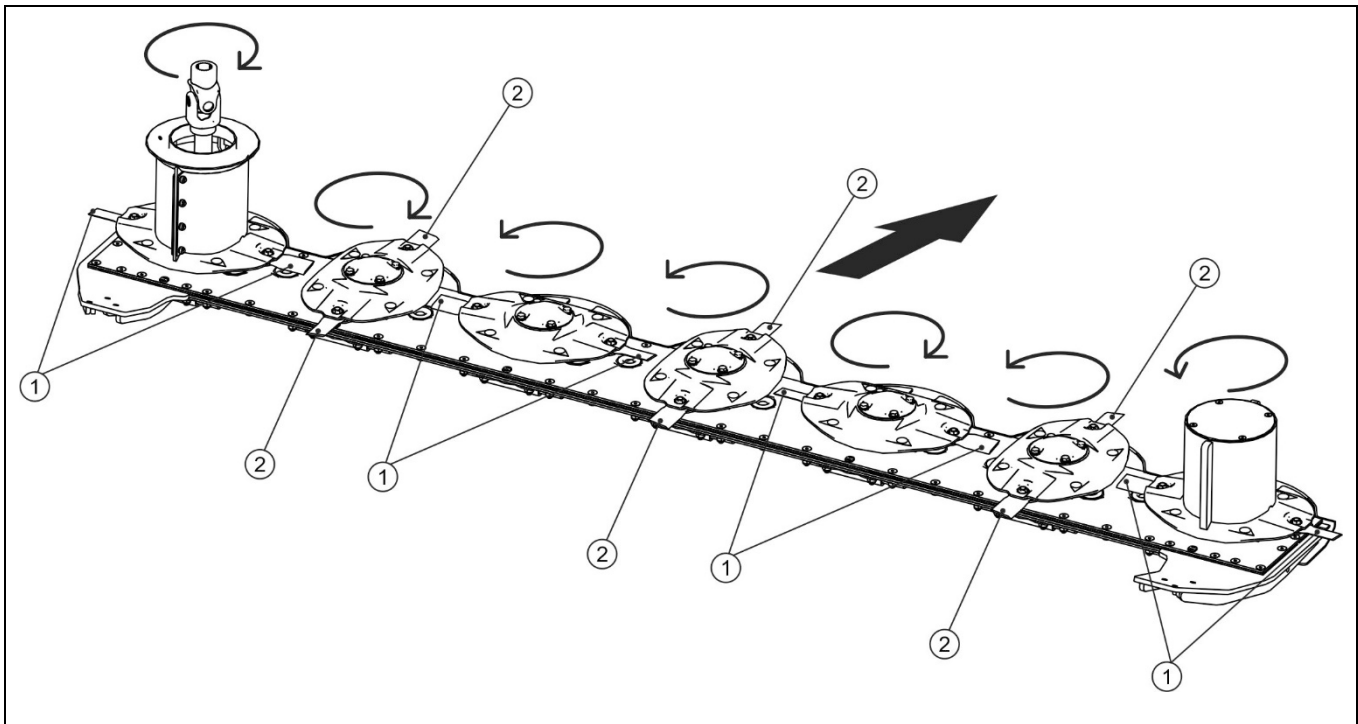

**FIGURE 5.2 Cutting disc rotation direction**

(1) right cutting knife, (2) left cutting knife

Due to different cutting disc rotation direction, cutter bar (FIGURE 5.2) is equipped with the right blades (A) and left blades (B). Rotation direction is indicated on the knife.



**ATTENTION**

Each time a knife hits an obstacle such as a stone or a branch, its technical condition must be inspected.

**5.1.2 INSPECTION AND REPLACEMENT OF SWATH CONDITIONER FLAIL BLADES (PDF300C)**



**DANGER**

During inspection and replacement of beater fingers, switch off tractor engine and remove the key from the ignition and disengage PTO shaft. Rest conditioning assembly on the ground on parking stands.

Regularly inspect beater fingers. Visually inspect beater fingers, their mountings and rubber blocks. Worn rubber blocks, distorted or broken fingers should be replaced. Fingers should be replaced in pairs to maintain balance.

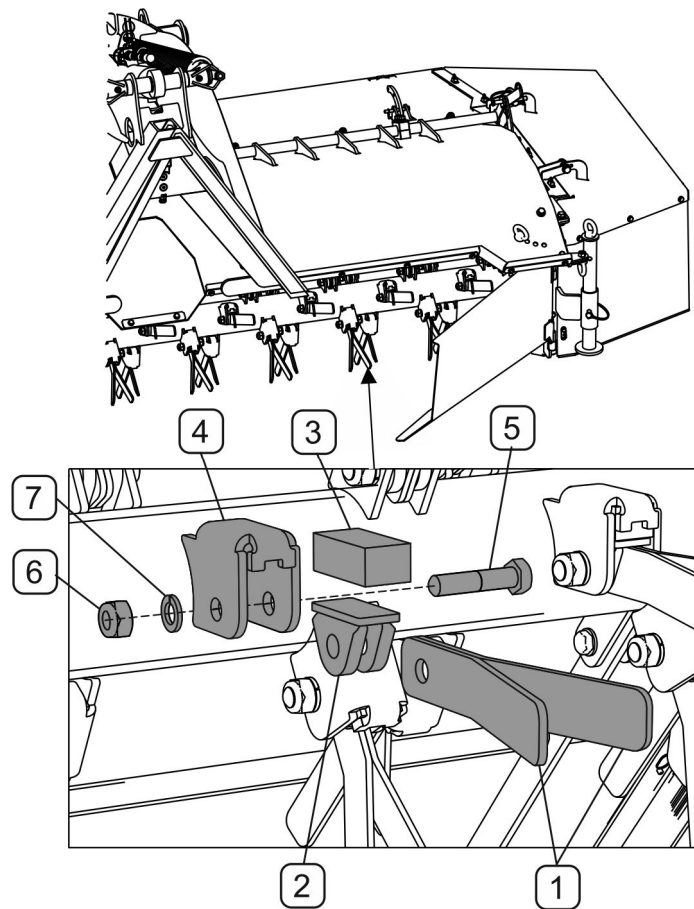

**FIGURE 5.3 Replacing the flail blades of the swath conditioner (PDF300C).**

(1) - flail blades, (2) - blade lock, (3) - rubber block, (4) - blade mount (5) - M12x55 kl.8.8 mounting bolt; (6) - M12 kl.8.8 self-locking nut; (7) - spring washer.

To replace the flail blades (FIGURE 5.3):

- unscrew the M12 self-locking nut (6)
- remove the M12x55 fixing bolt (5)
- remove a pair of flail blades (1) from the lock (2).

When replacing the flail blades pay attention to the condition of the fixing bolt (5) and rubber block (3). Excessively worn or damaged bolt or rubber block should be replaced. Installation of the new flail blades should be performed in reverse order. Nut (6) of the fixing bolt must be tightened so that the flail blades (1) can move freely in the blade lock (2).

## 5.2 DRIVE SYSTEM MAINTENANCE

Drive system maintenance involves general checking of intersecting axis gears, change or supplementing transmission oil deficiencies. In the event of damage to transmission, contact authorised service point in order to perform repairs.



### DANGER

Do not perform service or repair work under raised and unsupported machine.



Check oil level in intersecting axis gears daily.

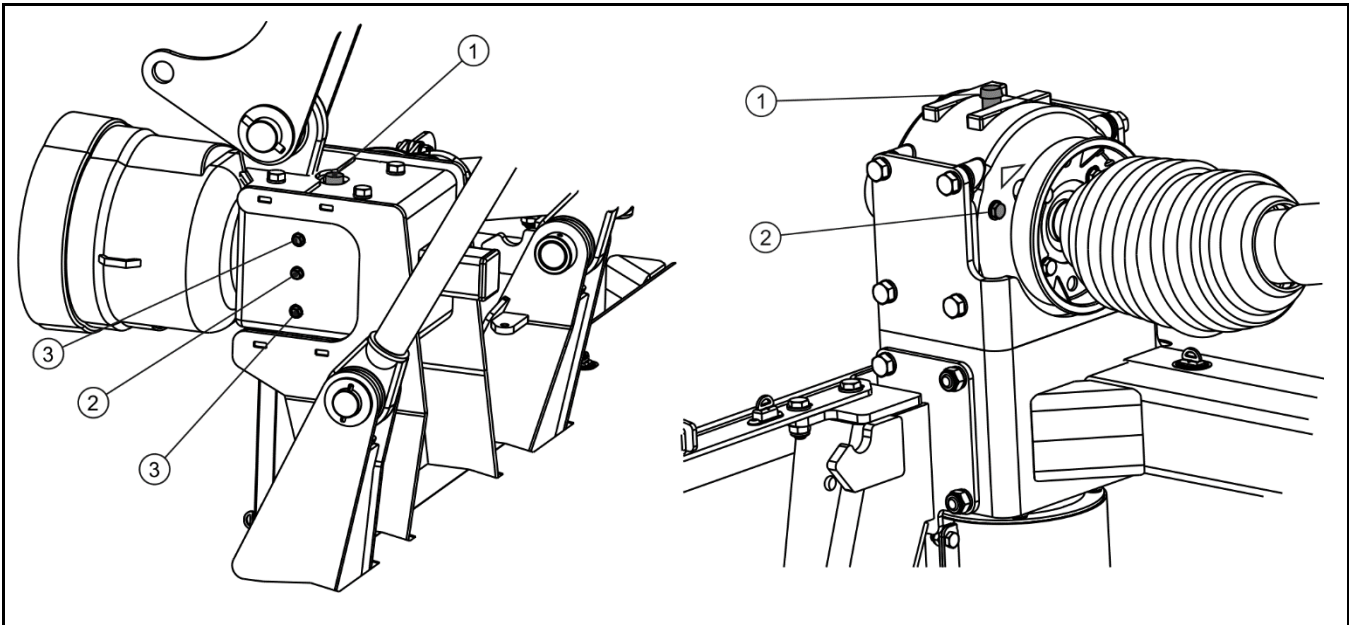

**FIGURE 5.4** Inspection points of gears

(1) filler plug, (2) inspection plug, (3) air vent plug

To check the oil level in intersecting axis gears (FIGURE 5.4):

- set mower level horizontally,
- unscrew inspection plug (2), oil level should reach the lower edge of the inspection plug opening (2),
- if necessary, supplement oil through inlet opening (1) to the required level.

In the same manner check oil level in the other gear.



### DANGER

When checking oil level and changing oil, use appropriate personal protection equipment i.e. protective clothing, safety shoes, gloves, safety goggles. Avoid contact of skin with oil.



Oil in both intersecting axis gears must be changed after the first 50 hours of work. The next oil change should be made after 500 hours of work or once a year, whichever occurs first.

Two intersecting axis gears are employed in PDF300 / PDF300C mower (FIGURE 5.5).

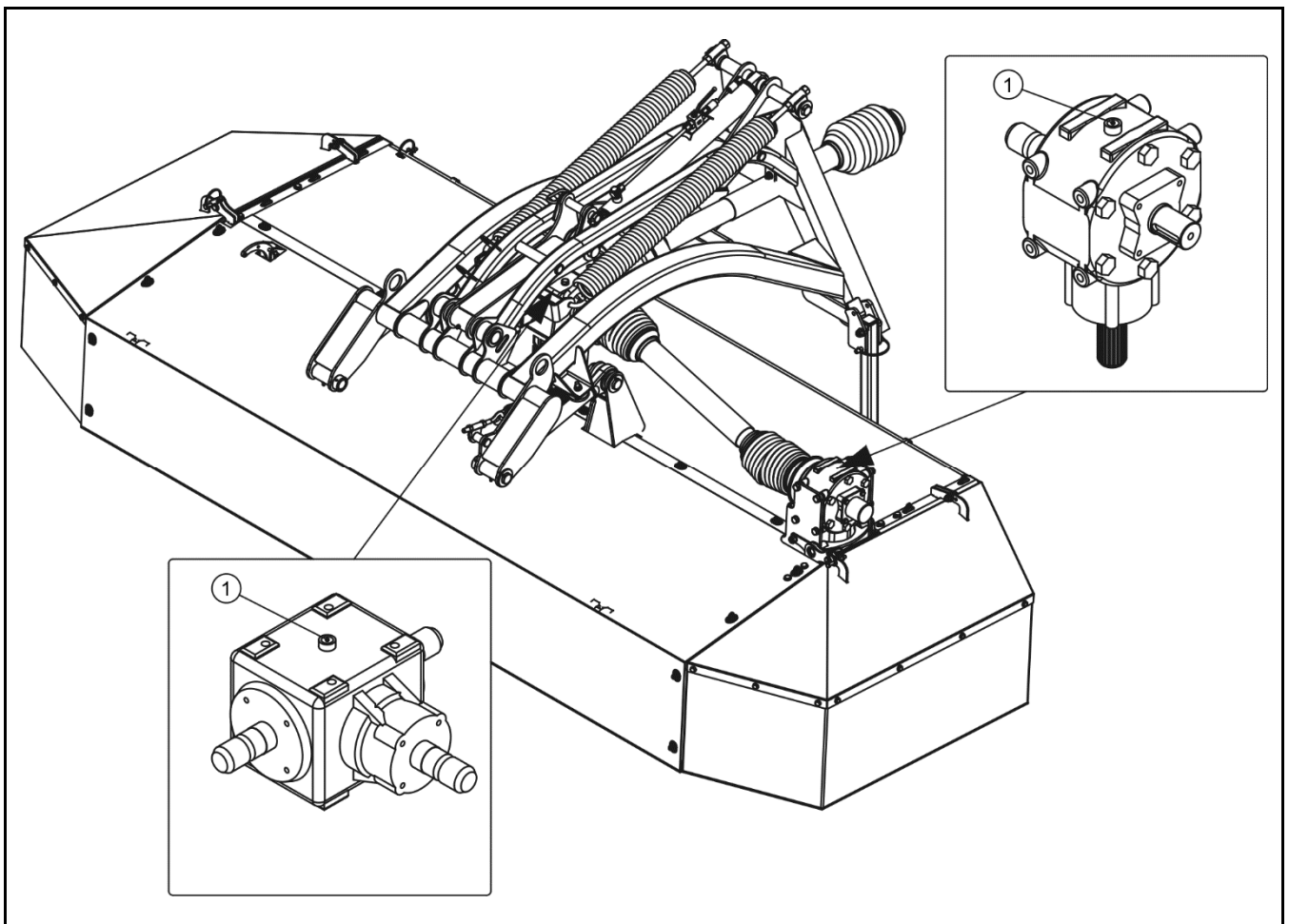

**FIGURE 5.5** Locations of intersecting axis gears

(1) filler plug

To change oil in intersecting axis gear:

- set mower on a hard surface and level the machine
- unscrew filler plug (1) (FIGURE 5.5),
- unscrew drain plug on lower part of gear transmission,
- drain oil into tight oil resistant container,
- if oil Manufacturer recommends flushing transmission with washing detergent, that operation should be performed according to the guidelines of the oil Manufacturer,
- tighten drain plug,
- add oil until oil flows out of inspection plug opening, found on side wall of gear transmission.

Used oil should be taken to the appropriate facility dealing with the re-use of this type of waste.

To lubricate intersecting axis gears use SAE90EP (80W90 GL-5) gear oil in quantity of 1.1 litre for each gear.

If a leak is noticed, carefully inspect seals and check oil level. Transmission operation with insufficient oil may cause permanent damage of the mechanism.

Repair of transmission during warranty period may only be performed at authorised mechanical workshops.

In addition to periodic inspection of intersecting axis gears, swath conditioner mowers (PDF300C) also require the monitoring of belt tension in swath conditioner belt drive.



### **DANGER**

**Prior to inspecting or adjusting transmission system belts  
switch off tractor engine and remove key from ignition.**



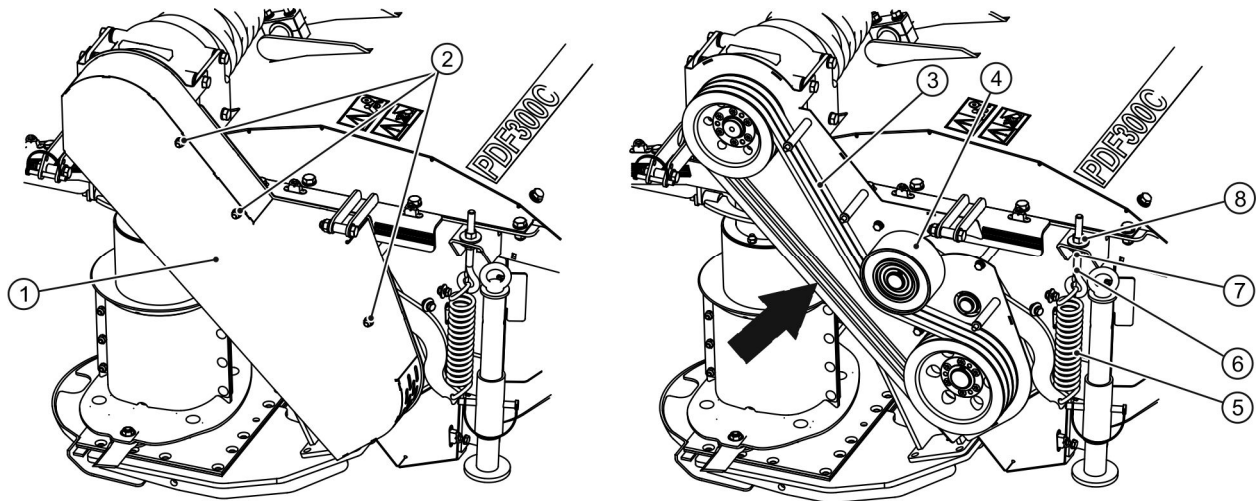

**FIGURE 5.6 PDF300C belt drive tension adjustment**

(1)- transmission guard; (2)- nuts; (3)- drive belt; (4)- tensioner; (5)- tensioner spring; (6)- tensioner bolt; (7)- locknut; (8)- adjustment nut.

Belt tension (FIGURE 5.6) can be adjusted using the adjustment nut (8) of the tensioner bolt (6). To do this, unscrew the locknut (7) and tighten the adjusting nut (8) on the bolt (6) to the point where the tensioner spring will be at a minimum tension. The deflection of the belt (3) measured at the mid point between the pulley on the intersecting axis gear and pulley of the conditioner shaft (marked with an arrow in the figure) should not exceed 10 mm under the pressure of 7.5 daN (kg).

If tension cannot be adjusted, replace belts for new ones. There are three SPB 1750 belts in the transmission system. To replace V-belts, loosen the spring tensioner wheel (4) by means of the adjustment nut (8) and remove belts from drive pulleys. After 2 hours of mower operation, check again the tension of belts of the conditioning assembly belt drive and readjust belts tension as necessary.

## 5.3 CUTTERBAR MAINTENANCE

Cutting unit maintenance involves periodical checking of oil level and changing of oil in cutter bar. In the event of damage to cutter bar contact authorised service point in order to perform repairs.

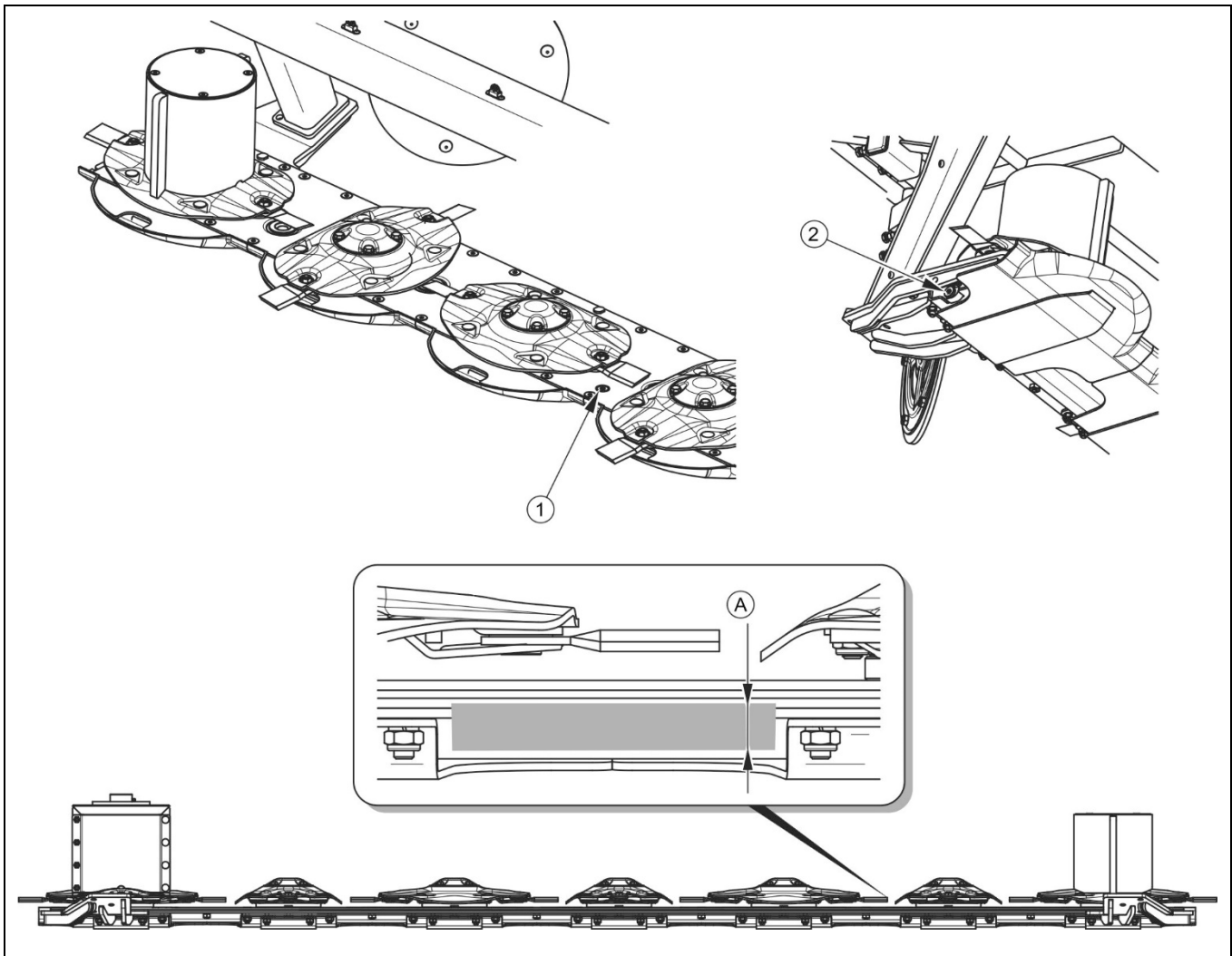

**FIGURE 5.7** Check oil level in cutter bar

(1)- inlet cap; (2)- drain plug; (A)- correct oil level 6 ÷ 8mm from the cutter bar bottom

Correct oil level (A) with cutter bar in horizontal position is 6 ÷ 8mm from the cutter bar bottom. To check oil level remove inlet cap (1) located between the third and fourth disk - (FIGURE 5.7). When oil is cold wait approximately 15 minutes before checking the oil level. Just check the oil level on a level cutter bar.



**Check oil level in cutter bar each time before beginning work.**

First oil change should be made after 50 hours of mower operation and then, after each 500 hours of operation or at least once in the season, whichever occurs first. Cutter bars are filled with 3.0 litre of transmission oil SAE90EP (80W90 GL-5). It is best to change oil immediately after completing work when cutter bar is still hot and impurities are mixed with oil.

In order to change oil in cutter bar:

- unscrew inspection filler plug (1) (FIGURE 5.7),
- raise cutterbar,
- unscrew drain plug (2) and drain oil to previously prepared basin,
- tighten drain plug (2),
- Position cutting unit horizontally and pour the required quantity of oil through the inlet (1),



**Oil in cutter bar must be changed after the first 50 hours of work. The next oil change should be made after 500 hours of work or once a year, whichever occurs first.**

If a leak is noticed, carefully inspect seals and check oil level. Mower operation with low oil level in cutter bar may cause lasting damage. Repairs of cutter bar during warranty period (except knife replacement) may only be performed at authorised mechanical workshops.

To ensure proper operation of the mower, regularly clean and lubricate drive disc articulated shaft (1) - (FIGURE 5.8). Failure to regularly clean and lubricate the articulated shaft (2) can lead to seizing of the connection and machine damage.

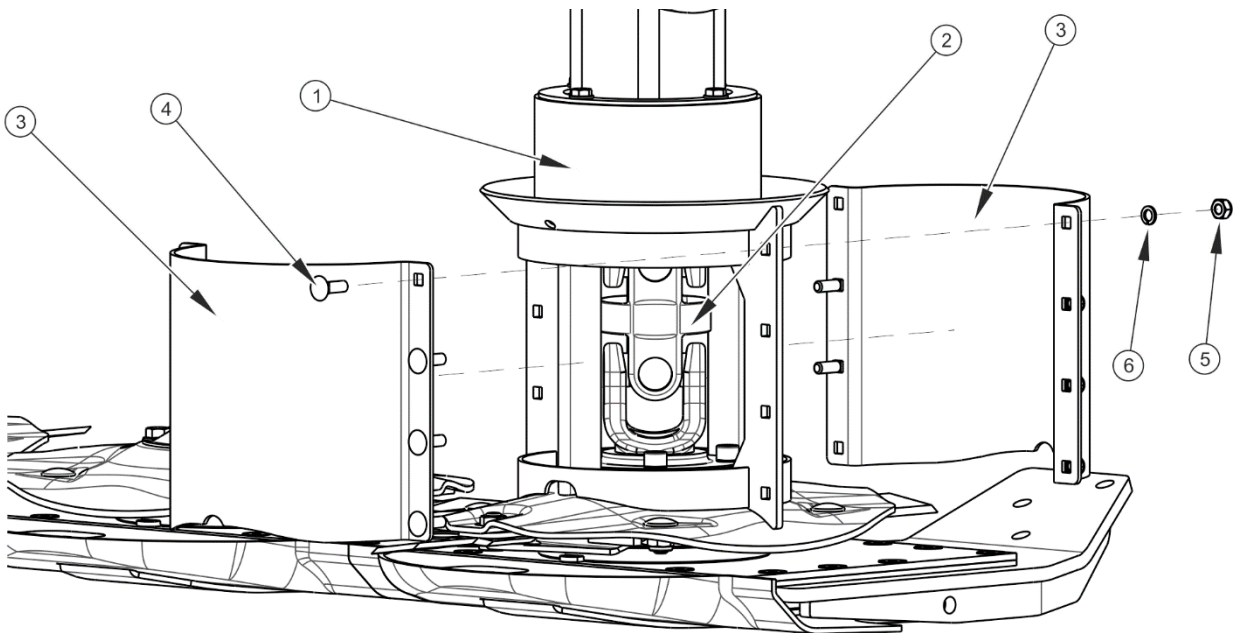

**FIGURE 5.8 Clean and lubricate the drive disk**

*(1) drive disc, (2) articulated shaft, (3) cover, (4) bolt, (5) nut (6) washer*

Required service actions:

- unscrew nuts (5) and take out bolts (4),
- Remove both covers (3),
- clean and lubricate the lubricated shaft (2), and clean the internal surfaces of covers,
- replace the covers and insert the bolts. The secure the connection with washers (6) and nuts (5).



**ATTENTION**

The dirt accumulated inside the drive disc such as grass clippings, sand, etc. can lead to seizure of the articulated shaft. Shaft seizure can damage the mower transmission.



Carry out maintenance of the drive disc at least twice during the grass mowing season and always after the season.

## 5.4 HYDRAULIC SYSTEM OPERATION

### DANGER



Before commencing whatever work on hydraulic system reduce the pressure in the system.

During work on hydraulic systems use the appropriate personal protection equipment i.e. protective clothing, footwear, gloves and eye protection. Avoid contact of skin with oil.

Always adhere to the principle that the oil in the mower hydraulic system and in the tractor hydraulic system are of the same type. Application of different types of oil is not permitted. In a new mower, the hydraulic system is filled with AGROL U hydraulic oil.

### ATTENTION



The condition of hydraulic system should be inspected regularly while using the machine.

The hydraulic system should be completely tight sealed. Inspect the seals when hydraulic ram cylinders are completely extended. In the event of confirmation of oil on hydraulic ram cylinder bodies ascertain origin of leak. Minimum leaks are permissible with symptoms of "sweating", however in the event of noticing leaks in the form of "droplets" stop using the machine until faults are remedied.

In the event of confirmation of an oil leak on hydraulic conduit connections, tighten connections, and if this does not remedy faults then change conduit or connection elements. Change of sub-assemblies is equally required in each instance of mechanical damage.

**TABLE 5.2 AGROL U HYDRAULIC OIL CHARACTERISTICS**

ITEM	NAME	UNIT	VALUE
1	Kinematic viscosity at 100°C	-	10.0- 11.5
2	Viscosity index, min.		>95
3	Pour point, max.	°C	<-24
4	Base number mgKOH/g	-	9.9
5	Flash-point	°C	>230

Because of its composition the oil applied is not classified as a dangerous substance, however long-term action on the skin or eyes may cause irritation. In the event of contact of oil with skin wash the place of contact with water and soap. Do NOT apply organic solvents (petrol, kerosene). Contaminated clothing should be changed to prevent access of oil to skin. In the event of contact of oil with eye, rinse with large quantity of water and in the event of the occurrence of irritation consult a doctor. Hydraulic oil in normal conditions is not harmful to the respiratory tract. A hazard only occurs when oil is strongly atomised (oil vapour), or in the case of fire during which toxic compounds may be released. Oil fires should be quenched with the use of carbon dioxide (CO<sub>2</sub>), foam or extinguisher steam. Do NOT use water for fire extinguishing.

Spilt oil should be immediately collected and placed in marked tight container. Used oil should be taken to the appropriate facility dealing with the re-use of this type of waste.



**Flexible hydraulic lines should be replaced after 4 years of use.**

## 5.5 LUBRICATION

Machine lubrication should be performed with the aid of a manually or foot operated grease gun, filled with generally available permanent grease. Before commencing lubrication insofar as is possible remove old grease and other contamination. Remove excess oil or grease



**When using the mower the user is obliged to observe lubrication instructions according to attached schedule. Excess lubrication substance causes depositing additional contaminants in places requiring lubrication, therefore it is essential to keep individual machine elements clean.**

Gear oil in cutter bar should be changed in accordance with recommendations given in SECTION „5.3 CUTTER BAR MAINTENANCE“. For detailed instructions on how to change oil in intersecting axis gears please refer to SECTION „5.2 DRIVE SYSTEM MAINTENANCE“. Lubrication points are shown in FIGURE 5.9 / 5.10 and detailed in TABLE „5.3 LUBRICATION POINTS“.

**TABLE 5.3 LUBRICATION POINTS**

ITEM	NAME	NUMBER OF LUBRICATION POINTS	TYPE OF GREASE	LUBRICATION FREQUENCY
1	Link pin	2	SOLID	20 hours
2	Suspension locking pin	1	SOLID	20 hours
3	Hydraulic cylinder eye	1	SOLID	50 hours
4	Stay spring adjustment bolts (threaded)	2	SOLID	2 times a year (before and after the mower's operating season)
5	Tensioning spring adjustment bolt (threaded)	1	SOLID	
6	Cutterbar double articulated connection joint	2	SOLID	60 hours

ITEM	NAME	NUMBER OF LUBRICATION POINTS	TYPE OF GREASE	LUBRICATION FREQUENCY
7	Swath guide axis shaft (PDF300)	2	SOLID	20 hours
8	Multi-splined drive shaft	1	SOLID	20 hours
9	Intersecting axis gear	2	OIL	500 hours
10	Cutter bar	1	OIL	500 hours
11	Link ball-and-socket joint eyes	3	SOLID	20 hours
12	PTO shaft for connection with tractor★			
13	PTO shaft★			
14	Swath conditioner shaft bearings (PDF300C)	2	SOLID	50 hours

*IMPORTANT! Marking description in Item column in TABLE 5.3 conforms with numbering shown in FIGURE 5.9 / 5.10.*

*★ PTO shaft lubrication should be performed according to the instructions of Manufacturer. For detailed information on maintenance please refer to maintenance instructions attached to the shaft.*



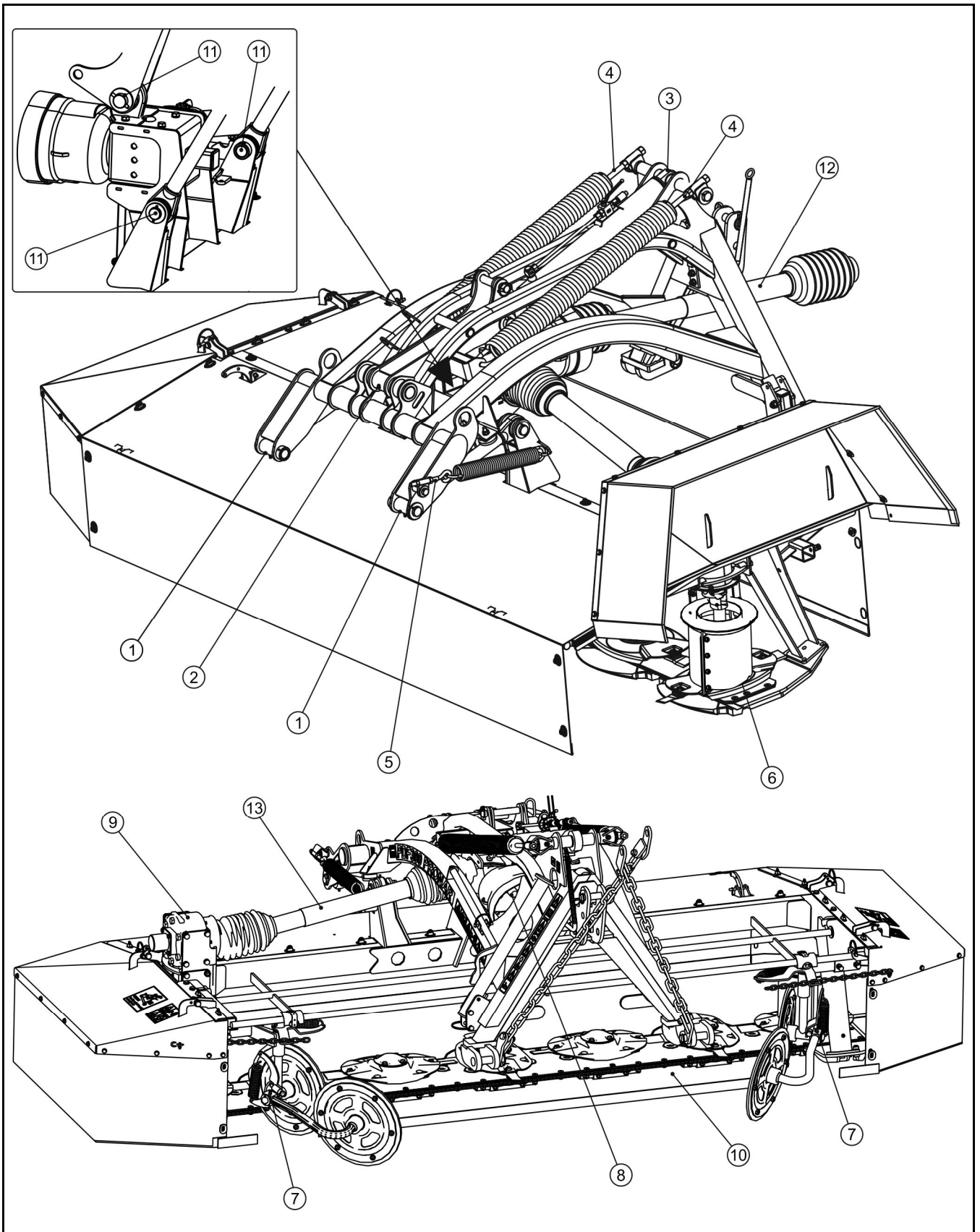

**FIGURE 5.9** Lubricating points of the PDF300 / PDF300C mower

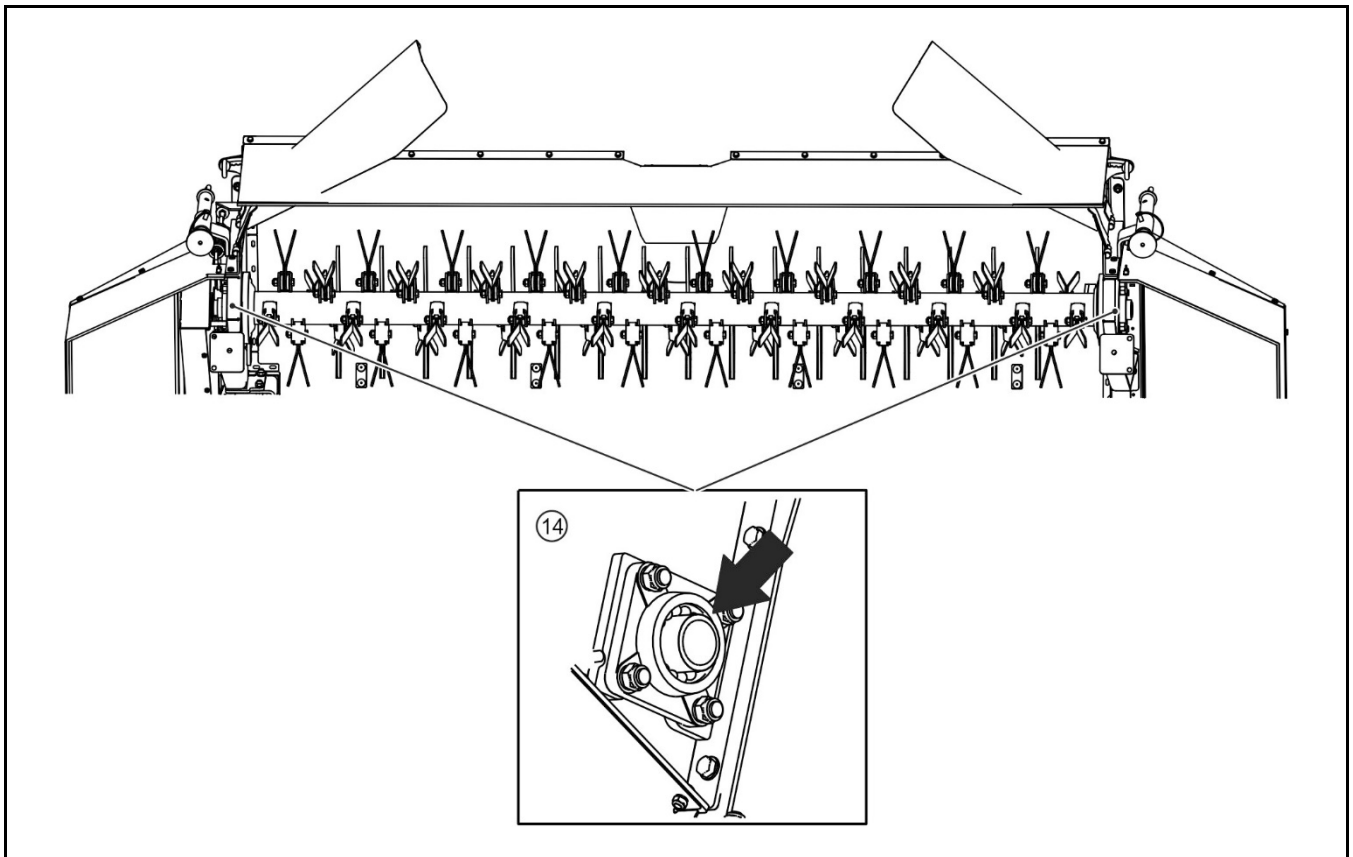

**FIGURE 5.10** Lubrication points on the PDF300C mower

## 5.6 STORAGE

After finishing work with disc mower carefully clean and wash it with water jet. While washing do not direct a strong water or steam jet at information and warning decals, bearings or hydraulic lines. Nozzle of pressure or steam washer should be kept at a distance of not less than 30 cm from cleaned surface.

After cleaning mower inspect the whole machine, inspect technical condition of individual elements. Used or damaged elements should be repaired or replaced.

In the event of damage to the paint coat, clean rust and dust from damaged area, degrease and then paint with undercoat and after it is dry paint with surface coat paint retaining colour uniformity and even thickness of protective coating. Until the time of touch-up painting, the damaged place may be covered with a thin layer of grease or anticorrosion preparation. Mower should be kept in closed or roofed building.

If the mower shall not be used for a long period of time, protect it against adverse weather conditions. Lubricate mower according to the instructions provided. In the event of prolonged work stoppage, it is essential to lubricate all elements regardless of the period of the last lubrication process. Additionally before the winter period apply grease to hitching system pins.



### **DANGER**

**NEVER** leave the triangular hitching system connected to the mower during storage. There is a danger that the triangular hitching system may get disconnected from the mower accidentally and cause personal injuries.

## 5.7 TIGHTENING TORQUE FOR NUT AND BOLT CONNECTIONS

Unless other tightening parameters are given, during maintenance repair work apply appropriate torque to tightening nut and bolt connections. Recommended tightening torque of most frequently applied nut and bolt connections are given in TABLE 5.4. Given values apply to non-lubricated steel bolts.

After the first 10 hours of operation, check thoroughly the tightening of bolt connections.

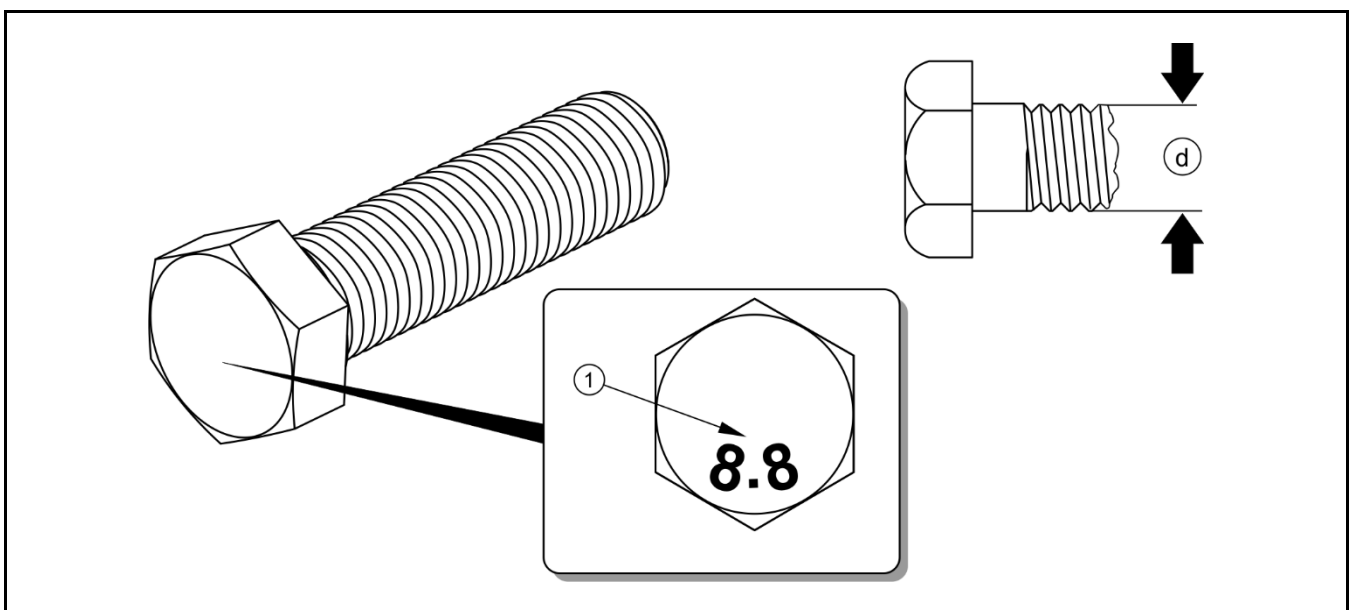

**FIGURE 5.11 Bolt with metric thread**

*(1) resistance class, (d) thread diameter*

**TABLE 5.4 TIGHTENING TORQUE FOR NUT AND BOLT CONNECTIONS**

THREAD DIAMETER (D) [MM]	5.8 <sup>(1)</sup>	8.8 <sup>(1)</sup>	10.9 <sup>(1)</sup>
	TIGHTENING TORQUE [NM]		
M6	8	10	15
M8	18	25	36
M10	37	49	72
M12	64	85	125

THREAD DIAMETER (D) [MM]	5.8 <sup>(1)</sup>	8.8 <sup>(1)</sup>	10.9 <sup>(1)</sup>
	TIGHTENING TORQUE [NM]		
M14	100	135	200
M16	160	210	310
M20	300	425	610
M24	530	730	1050
M27	820	1150	1650
M30	1050	1450	2100

<sup>(1)</sup> – resistance class according to DIN ISO 898 standard



### ATTENTION

Should it be necessary to change individual parts, use only original parts or those indicated by the Manufacturer. Non-adherence to these requirements may put the user and other people's health and life at risk, and also damage the machine.

## 5.8 TROUBLESHOOTING

**TABLE 5.5 FAULTS AND MEANS OF REMEDYING THEM**

TYPE OF FAULT	CAUSE	REMEDY
Mower cutting unit cannot be lifted or lowered using the hydraulic cylinder	Lifting arm interlocked with a pin	Remove blocking pin
	Incorrectly connected or damaged quick coupler	Check quick couplers and manner of their connection
	The tractor's hydraulic system is out of order	Check condition of tractor hydraulic system
Stubble is uneven	Cutter bar is excessively load relieved	Set load relief spring appropriately
	Tractor PTO rotation speed too low	Maintain correct, constant PTO speed
	Worn cutting blades	Turn blades onto the second side or replace
	Incorrect cutting angle	Set appropriate cutter bar inclination by adjustment of top link
Excessive vibration during work	Damaged or missing flail blade	Check flail blades, if necessary replace
	Damaged PTO shaft	Check shafts, if necessary replace
	Damaged cutterbar bearing	Repair at authorised service point
Excessive heating of intersecting axis gear or cutterbar	Incorrect oil level	Check oil level.
	Damaged bearing	Repair at authorised service point
Mower drive stops during cutting	Shaft overload clutch activated as a result of cutting discs being blocked	Disconnect power from mower; remove collected grass or foreign body from cutting unit
	Damaged cog in cutterbar	Repair at authorised service point
	Damaged intersecting axis gear	Repair at authorised service point

# NOTES

A series of horizontal dotted lines for writing notes.

