



PRONAR Sp. z o.o.

17-210 NAREW, UL. MICKIEWICZA 101A, PODLASKIE PROVINCE

phone:	+48 085 681 63 29	+48 085 681 64 29
	+48 085 681 63 81	+48 085 681 63 82
fax:	+48 085 681 63 83	+48 085 682 71 10

www.pronar.pl

OPERATOR'S MANUAL

MANURE SPREADER

PRONAR NV161/1, PRONAR NV161/2

PRONAR NV161/3, PRONAR NV161/4

PRONAR NV161/5

TRANSLATION OF THE ORIGINAL COPY OF THE MANUAL

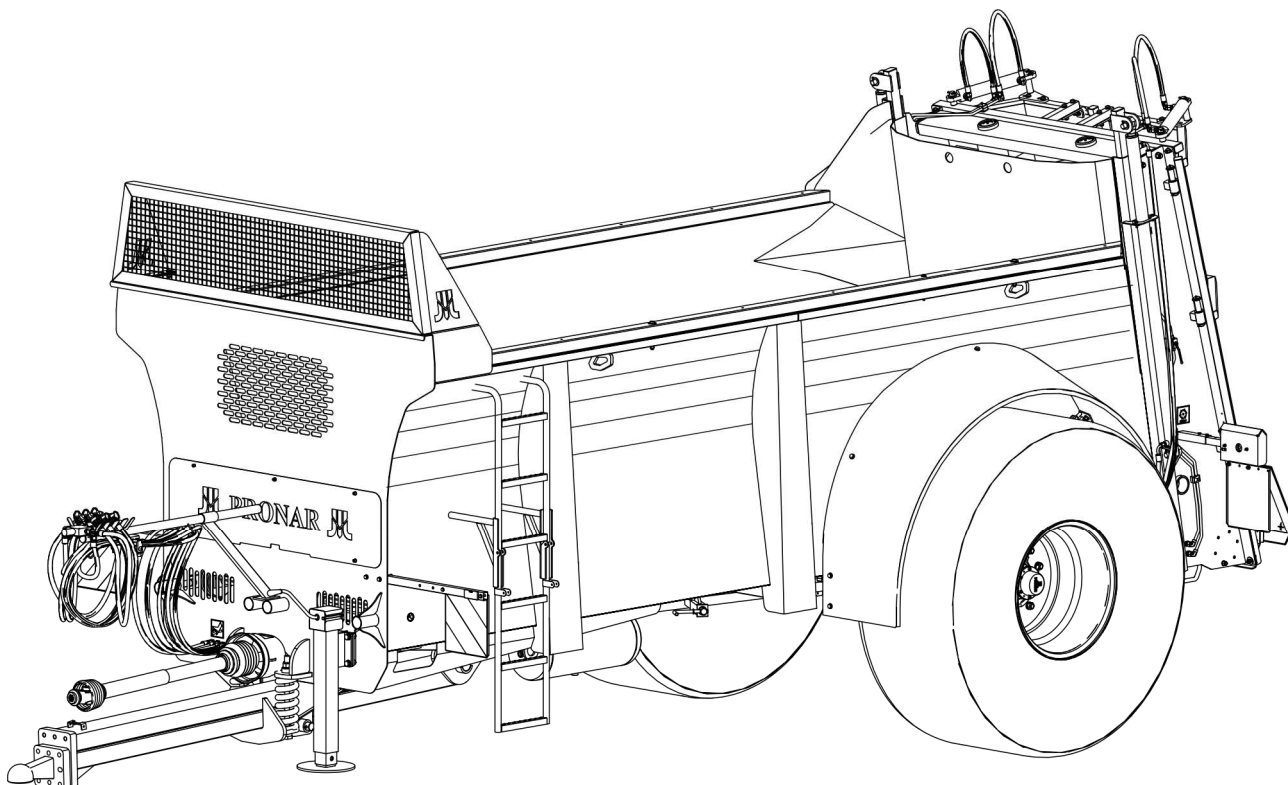

EDITION 2C-10-2020

PUBLICATION NO. 523N-00000000-UM



INTRODUCTION

Information contained herein is current at date of publication. As a result of improvements, some numerical values and illustrations contained in this publication may not correspond to the factual specification of the machine supplied to the user. The manufacturer reserves the right to introduce design changes in machines produced that facilitate operation and improve the quality of their work, without making minor amendments to this Operator's Manual.

This Operator's Manual is an integral part of the machine's documentation. Before using the machine, the user must carefully read this Operator's Manual and observe all recommendations. This guarantees safe operation and ensures failure-free work of the machine. The machine is designed to meet obligatory standards, documents and legal regulations currently in force.

The Operator's Manual describes the basic safety rules and operation of Pronar NV161/1, NV161/2, NV161/3, NV161/4 and NV161/5 manure spreader.

If the information stated in the Operator's Manual needs clarification then the user should refer for assistance to the sale point where the machine was purchased or to the Manufacturer.

MANUFACTURER'S ADDRESS:

*PRONAR Sp. z o.o.
ul. Mickiewicza 101A
17-210 Narew*

CONTACT TELEPHONES

+48 085 681 63 29

+48 085 681 64 29

+48 085 681 63 81

+48 085 681 63 82

SYMBOLS APPEARING IN THIS OPERATOR'S MANUAL

Information, descriptions of danger and precautions and also recommendations and prohibitions associated with user safety instructions are marked:



and also preceded by the word "**DANGER**". Failure to observe the instructions may endanger the machine operator's or other person's health or life.

Particularly important information and instructions, the observance of which is essential, are distinguished in the text by the sign:



and also preceded by the word "**ATTENTION**". Failure to observe the instructions may lead to damage to the machine as a result of improper operation, adjustment or use.

In order to focus the user's attention on the need to perform maintenance, the relevant section of the Operator's Manual is marked with the pictogram:



Additional tips and advice for machine operation are marked:



and also preceded by the word "**TIP**".

DIRECTIONS USED IN THIS OPERATOR'S MANUAL

Left side – side to the left hand of the operator facing in the direction of machine's forward travel.

Right side – side to the right hand of the operator facing in the direction of machine's forward travel.

REQUIRED MAINTENANCE ACTIONS

Maintenance actions described in the manual are marked with the sign: ➔

Result of maintenance/adjustment actions or comments concerning the performance of actions are marked with the sign: ⇨

**PRONAR Sp. z o.o.**

ul. Mickiewicza 101 A

17-210 Narew, Polska

tel./fax (+48 85) 681 63 29, 681 63 81, 681 63 82,
681 63 84, 681 64 29

fax (+48 85) 681 63 83

<http://www.pronar.pl>e-mail: pronar@pronar.pl**EC DECLARATION OF CONFORMITY OF THE MACHINERY**

PRONAR Sp. z o.o. declares with full responsibility, that the machine:

Description and identification of the machinery					
Generic denomination and function:	Manure spreader				
Type:	PS-R				
Model:	NV161/1	NV161/2	NV161/3	NV161/4	NV161/5
Serial number:					
Commercial name:	Manure spreader PRONAR NV161/1 Manure spreader PRONAR NV161/2 Manure spreader PRONAR NV161/3 Manure spreader PRONAR NV161/4 Manure spreader PRONAR NV161/5				

to which this declaration relates, fulfills all the relevant provisions of the Directive **2006/42/EC** of The European Parliament and of The Council of 17 May 2006 on machinery, and amending Directive 95/16/EC (Official Journal of the EU, L 157/24 of 09.06.2006).

The person authorized to compile the technical file is the Head of Research and Development Department at PRONAR Sp. z o.o., 17-210 Narew, ul. Mickiewicza 101A, Poland.

This declaration relates exclusively to the machinery in the state in which it was placed on the market, and excludes components which are added and/or operations carried out subsequently by the final user.

Narew, the 2018-05-24

Place and date

PRONAR
Spółka z o.o.
17-210 Narew, ul. Mickiewicza 101 A
tel. (095) 681 6329, 681 6429
fax (055) 681 6383

Z-CIA DZIEKTOBA
dla Technicznych
Członków Zarządu

Roman Melicianiuk

Full name of the empowered person
position, signature

CONTENTS

1	BASIC INFORMATION	1.1
1.1	IDENTIFICATION	1.2
1.1.1	AXLE IDENTIFICATION	1.4
1.1.2	LIST OF FACTORY NUMBERS	1.5
1.2	INTENDED USE	1.5
1.3	EQUIPMENT	1.8
1.4	TERMS & CONDITIONS OF WARRANTY	1.9
1.5	TRANSPORT	1.11
1.5.1	TRANSPORT ON VEHICLE	1.11
1.5.2	INDEPENDENT TRANSPORT BY THE USER	1.12
1.6	ENVIRONMENTAL HAZARDS	1.13
1.7	WITHDRAWAL FROM USE	1.14
2	SAFETY ADVICE	2.1
2.1	BASIC SAFETY RULES	2.2
2.1.1	USE OF MANURE SPREADER	2.2
2.1.2	HITCHING AND UNHITCHING THE MANURE SPREADER, LOADING THE LOAD BOX	2.3
2.1.3	TRANSPORTING THE MACHINE	2.4
2.1.4	HYDRAULIC SYSTEM AND PNEUMATIC SYSTEM	2.6
2.1.5	OPERATION WITH PTO	2.7
2.1.6	MACHINE OPERATION	2.9
2.1.7	CLEANING, MAINTENANCE AND REPAIRS	2.9
2.2	DESCRIPTION OF RESIDUAL RISK	2.11
2.3	INFORMATION AND WARNING DECALS	2.12

3 DESIGN AND OPERATION	3.1
3.1 TECHNICAL SPECIFICATION	3.2
3.2 MANURE SPREADER DESIGN	3.4
3.2.1 GENERAL DESIGN	3.4
3.2.2 FEEDING MECHANISM	3.5
3.2.3 HYDRAULIC SYSTEM OF FEEDING MECHANISM	3.8
3.2.4 DRIVE TRANSMISSION	3.9
3.2.5 TWO-BEATER VERTICAL SPREADER UNIT	3.11
3.2.6 TAILGATE OPENING HYDRAULIC SYSTEM	3.12
3.2.7 HYDRAULIC SYSTEM OF THE SLIDE GATE	3.13
3.2.8 MAIN BRAKE	3.14
3.2.9 PARKING BRAKE	3.19
3.2.10 LIGHTING SYSTEM	3.20
4 CORRECT USE	4.1
4.1 PREPARING FOR WORK BEFORE FIRST USE	4.2
4.1.1 CHECKING THE MANURE SPREADER AFTER DELIVERY	4.2
4.1.2 PREPARING THE MANURE SPREADER FOR THE FIRST USE	4.3
4.1.3 TEST START	4.4
4.2 TECHNICAL CONDITION INSPECTION	4.6
4.3 HITCHING AND DISCONNECTING MANURE SPREADER FROM TRACTOR	4.7
4.4 LOADING THE LOAD BOX	4.12
4.5 SPREADING AND ADJUSTING FERTILIZER DOSE	4.13
4.5.1 ADJUSTING FERTILIZER DOSE	4.13
4.5.2 SPREADING MANURE IN THE FIELD	4.14
4.6 SPREADING MECHANISM CLOGGING	4.16
4.7 PROPER USE AND MAINTENANCE OF TYRES	4.17

5 MAINTENANCE	5.1
5.1 PRELIMINARY INFORMATION	5.2
5.2 MAINTENANCE OF BRAKES AND AXLES	5.2
5.2.1 PRELIMINARY INFORMATION	5.2
5.2.2 INITIAL INSPECTION OF AXLE BRAKES	5.3
5.2.3 CHECKING BRAKE SHOE LININGS FOR WEAR	5.4
5.2.4 CHECKING WHEEL AXLE BEARINGS FOR SLACKNESS	5.5
5.2.5 ADJUSTMENT OF SLACKNESS OF WHEEL AXLE BEARINGS	5.7
5.2.6 MOUNTING AND DISMOUNTING WHEEL, INSPECTION OF WHEEL NUT TIGHTENING	5.8
5.2.7 CHECKING AIR PRESSURE IN TYRES, EVALUATING TECHNICAL CONDITION OF TYRES AND STEEL WHEELS	5.10
5.2.8 MECHANICAL BRAKES ADJUSTMENT	5.11
5.2.9 CHANGE OF PARKING BRAKE CABLE AND ADJUSTMENT OF CABLE TENSION.	5.15
5.3 PNEUMATIC SYSTEM MAINTENANCE	5.18
5.3.1 PRELIMINARY INFORMATION	5.18
5.3.2 CHECKING AIR TIGHTNESS AND VISUAL INSPECTION OF PNEUMATIC SYSTEM	5.19
5.3.3 CLEANING THE AIR FILTERS	5.20
5.3.4 DRAINING WATER FROM AIR TANK	5.22
5.3.5 CLEANING THE DRAIN VALVE	5.23
5.3.6 CLEANING AND MAINTAINING PNEUMATIC CONDUIT CONNECTIONS AND PNEUMATIC SOCKETS	5.23
5.3.7 REPLACEMENT OF PNEUMATIC CONDUIT	5.24
5.4 HYDRAULIC SYSTEM OPERATION	5.25
5.5 MAINTENANCE OF MANURE SPREADER GEARS	5.27
5.6 MANURE SPREADER LUBRICATION	5.30
5.7 CHECKING AND ADJUSTMENT OF TENSION OF FLOOR CONVEYOR CHAINS	5.36

5.8	MANURE SPREADER CLEANING	5.37
5.9	PREPARATION FOR END OF SEASON	5.39
5.10	PREPARATION FOR THE BEGINNING OF A NEW FIELDWORK SEASON	5.40
5.11	STORAGE	5.41
5.12	MAINTENANCE OF ELECTRICAL SYSTEM AND WARNING ELEMENTS	5.42
5.12.1	PRELIMINARY INFORMATION	5.42
5.12.2	CHANGING BULBS	5.43
5.13	TIGHTENING TORQUE FOR NUT AND BOLT CONNECTIONS	5.43
5.14	TROUBLESHOOTING	5.45

SECTION

1

**BASIC
INFORMATION**

1.1 IDENTIFICATION

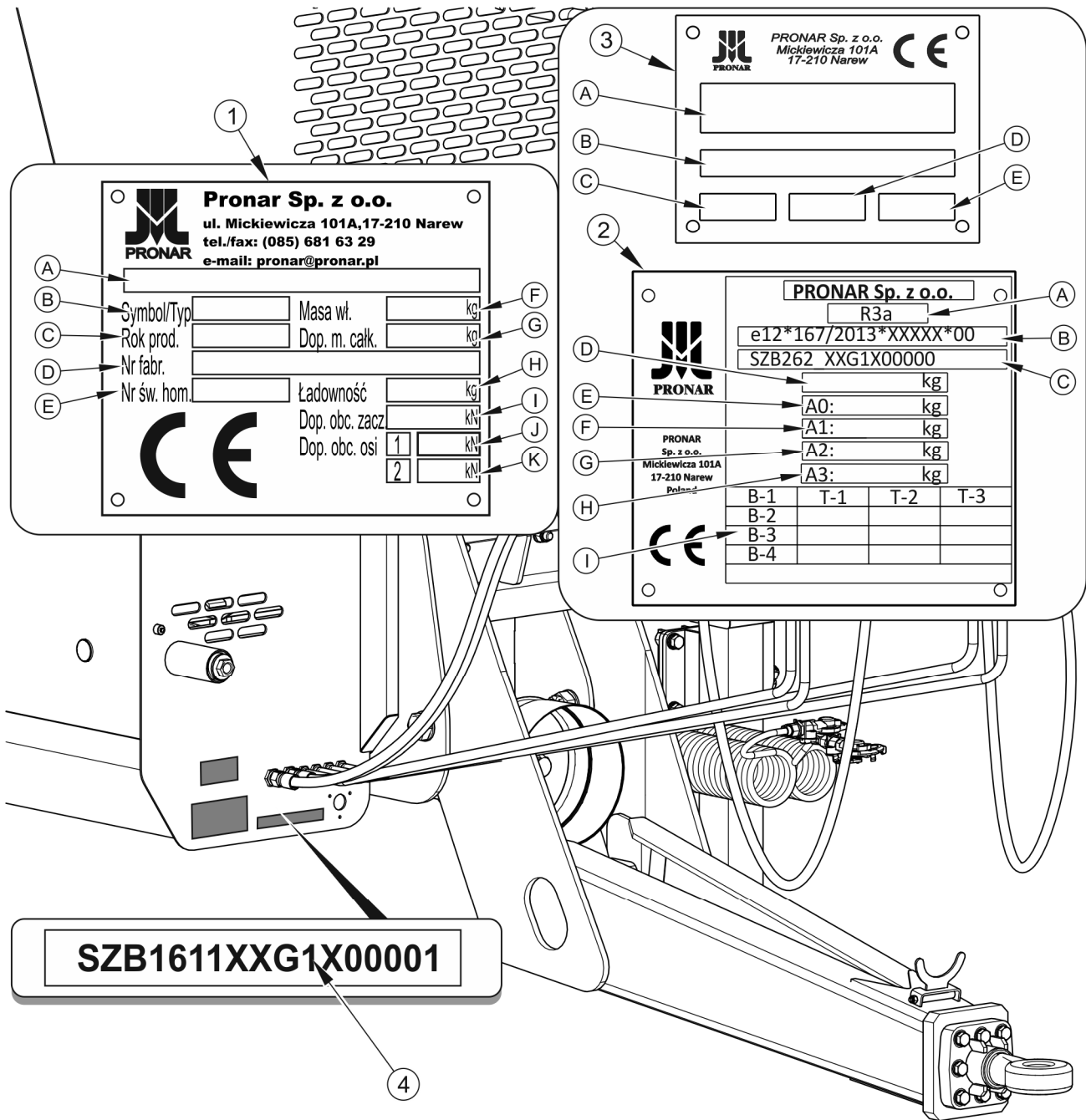

FIGURE 1.1 Manure spreader identification

(1) data plate – version standard, (2) data plate – version EU, (3) data plate CE– version EU, (4) serial number

The manure spreader is marked with the data plate (1) – version standard, or (2) and (3) - version EU and the factory number (4) located on a gold painted rectangle. The serial number and data plate are located on the front wall of the load box - figure (1.1).

When buying the manure spreader check that the factory numbers on the machine agree with the number written in the *WARRANTY BOOK*, in the sales documents and in the *OPERATOR'S MANUAL*. The meanings of the individual fields found on the data plate are presented in the table (1.1), (1.2), (1.3).

TABLE 1.1 Markings on data plate- version standard

ITEM	MARKING
A	General description and purpose
B	Symbol /Type
C	Year of manufacture
D	Seventeen digit serial number (VIN)
E	Official certificate number
F	Machine tare weight
G	Maximum gross weight
H	Carrying capacity
I	Permissible hitching system loading
J	Permissible front axle load
K	Permissible rear axle load

TABLE 1.2 Markings on data plate- version EU

ITEM	MARKING
A	Vehicle category according to R167/2013
B	Official certificate number
C	Seventeen digit serial number (VIN)
D	Maximum gross weight
E	Permissible hitching system loading
F	Permissible load – axle 1
G	Permissible load – axle 2
H	Permissible load – axle 3
I	Technically permissible towable mass for each chassis/braking configuration for R or S category Vehicle

TABLE 1.3 Markings on data plate CE - version EU

ITEM	MARKING
A	General description and purpose
B	Seventeen digit serial number (VIN)
C	Type
D	Year of manufacture
E	Model

1.1.1 AXLE IDENTIFICATION

The factory number of the axle shaft and its type are stamped onto the data plate (2) secured to the axle shaft beam (1) – figure (1.2).

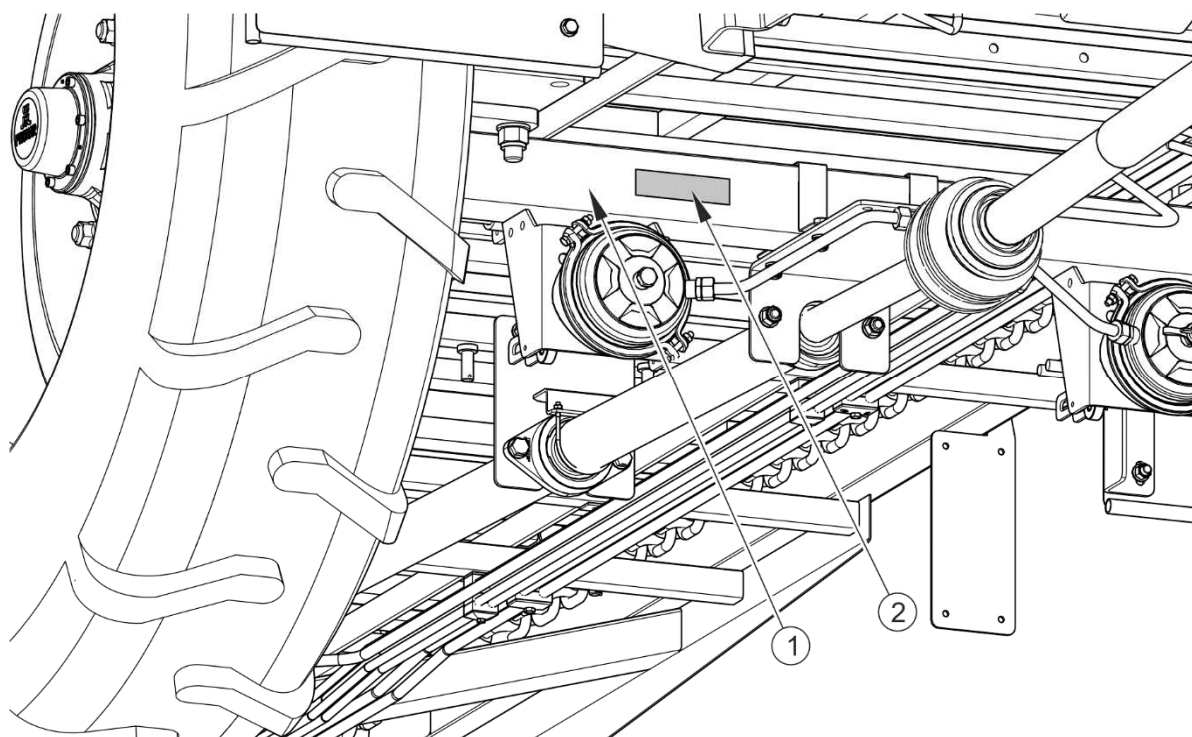

FIGURE 1.2 Location of the axle data plate

(1) axle, (2) data plate

1.1.2 LIST OF FACTORY NUMBERS



TIP

In the event of ordering a replacement part or if problems appear it is often essential to give the factory numbers of parts or the VIN number of the manure spreader, therefore it is recommended that these numbers are inscribed in the spaces below.

VIN

S	Z	B	1	6	1		X	X			X				
---	---	---	---	---	---	--	---	---	--	--	---	--	--	--	--

AXLE FACTORY NUMBER AND TYPE

--

1.2 INTENDED USE

Pronar single axle manure spreader is designed for uniform spreading of all kinds of manure, peat and compost. The manure spreader must not be used in any way other than that described above. Using it as intended also involves all actions connected with the safe and proper operation and maintenance. The manure spreader is not intended or designed for transporting people or animals.

ATTENTION!

The manure spreader must not be used for purposes other than those for which it is intended, in particular:



- for transporting people and animals,
- for applications in which the maximum carrying capacity is exceeded,
- for spreading and transporting toxic and flammable materials,
- for spreading fluids, sand or fibrous substances,
- for transporting unsecured loads, which may move in the load box during transport,

- for transporting machines and equipment with high centre of gravity deteriorating manure spreader stability,
- for transporting construction materials, single objects or any materials and substances outside the scope of intended use of the manure spreader.

The manure spreader is constructed according to current safety requirements and engineering standards. The brake system and the light and indicator system meet the requirements of road traffic regulations. The maximum speed of the manure spreader on public roads is 30 km/h in Poland (pursuant to Traffic Law Act of June 20th 1997, article 20). In the countries where the manure spreader is used, the limits stipulated by the road traffic legislation in force in a given country must be observed. The manure spreader speed must not, however, be greater than the maximum design speed.

Using it as intended also involves all actions connected with the safe and proper operation and maintenance of the machine. In connection with this the user is obliged to:

- carefully read the *OPERATOR'S MANUAL* of the manure spreader and the *WARRANTY BOOK* and conform with the recommendations contained in these documents,
- understand the manure spreader's operating principle and how to operate it safely and correctly,
- adhere to the established maintenance and adjustment plans,
- comply with general safety regulations while working,
- prevent accidents,
- comply with the road traffic regulations and transport regulations in force in a given country, in which the manure spreader is used,
- carefully read the Operator's Manual and comply with its recommendations,
- only hitch the manure spreader to an agricultural tractor which fulfils all the requirements made by the Manufacturer of the manure spreader.

The manure spreader may only be used by persons, who:

- are familiar with the contents of this publication and with the contents of the Operator's Manual of the agricultural tractor,
- have been trained in manure spreader operation and work safety,
- have the required authorisation to drive and are familiar with the road traffic regulations and transport regulations.

TABLE 1.4 Agricultural tractor's requirements

CONTENTS	UNIT	REQUIREMENTS
Braking system - sockets		
Single conduit pneumatic system	-	according to A DIN 74 294
Double conduit pneumatic system	-	according to ISO 1728
Hydraulic system	-	according to ISO 7421-1
Pressure rating of the system		
Single conduit pneumatic system	bar	5.8 - 6.5
Double conduit pneumatic system	bar	6.5
Hydraulic system	bar / MPa	150 / 15
Hydraulic system		
Number of connections	-	2 (standard) + 4 (options)
Hydraulic oil	-	L-HL32 Lotos ⁽¹⁾
Pressure rating of the system	bar / MPa	160 / 16
Electrical system		
Electrical system voltage	V	12
Connection socket	-	7-pole compliant with ISO 1724

CONTENTS	UNIT	REQUIREMENTS
Other requirements		
PTO RPM		
NV161/1, NV161/2	RPM	540
NV161/3, NV161/4, NV161/5	RPM	1,000
The required minimum power		
NV161/1	hp / /kW	70 / 51.5
NV161/2	hp / /kW	80 / 58.8
NV161/3	hp / /kW	90 / 66.2
NV161/4	hp / /kW	100 / 73.5
NV161/5	hp / /kW	120 / 88.2
Minimum static vertical load capacity (S)		
NV161/1	kg	2,000
NV161/2	kg	2,500
NV161/3	kg	3,000
NV161/4	kg	3,000
NV161/5	kg	4,000

⁽¹⁾ – use of other oil is permitted on condition that it may be mixed with the oil in the manure spreader. Detailed information may be found on the product information card.

1.3 EQUIPMENT

When buying the manure spreader check completeness of the machine.

TABLE 1.5 Manure spreader equipment

EQUIPMENT	STANDARD	ADDITIONAL	OPTIONS
Operator's Manual	•		
Warranty book	•		

EQUIPMENT	STANDARD	ADDITIONAL	OPTIONS
Connection lead for the electrical system	•		
Wheel chocks	•		
PTO shaft for connection of manure spreader with tractor		•	
Tailgates		•	
Slide gate		•	
Metal mudguards		•	
Slow-moving vehicle warning sign		•	
Warning reflective triangle		•	
Fixed drawbar eye Ø50			•
Rotating drawbar eye Ø50			•
Ball drawbar eye K80.			•
Fixed drawbar eye Ø40			•

Recommended PTO shafts with shear bolt clutch (2 700 Nm) for connecting the manure spreader with tractor:

- manufacturer: Bondioli & Pavesi, type 7 G7N 121 CE 007 R09
- manufacturer: Bondioli & Pavesi, type 7 G7N 121 CE 008 R09

1.4 TERMS & CONDITIONS OF WARRANTY

PRONAR Sp. z o.o. Narew guarantees the reliable operation of the machine when it is used according to its intended purpose as described in the *OPERATOR'S MANUAL*. The repair period is specified in the *WARRANTY BOOK*.

The warranty does not cover those parts and sub-assemblies of the machine which are subject to wear in normal usage conditions, regardless of the warranty period. Consumables include the following parts/sub-assemblies:

- drawbar hitching eye,
- pneumatic system connector filters,
- tyres,
- brake shoes,
- bulbs and LED lamps,
- seals,
- chains,
- spreader unit knives,
- gear wheels,
- bearings.

The warranty service only applies to factory defects and mechanical damage that is not due to the user's fault.



TIP

Demand that the seller carefully and precisely fills out the Warranty Book and warranty repair coupons. A missing date of purchase or sale point stamp, may make the user ineligible for any warranty repair or refund.

In the event of damage arising from:

- mechanical damage which is the user's fault, road accidents,
- inappropriate use, adjustment or maintenance, use of the machine for purposes other than those for which it is intended,
- use of damaged machine,
- repairs carried out by unauthorised persons, repairs carried out improperly,
- making unauthorised alterations to machine design,

the user will lose the right to warranty service.

The user is obliged to report immediately on noticing any wear in the paint coating or traces of corrosion, and to have the faults rectified whether they are covered by the warranty or not. For detailed Terms & Conditions of Warranty, please refer to the *WARRANTY BOOK* attached to each machine.

Modification of the manure spreader without the written consent of the Manufacturer is forbidden. In particular, do NOT weld, drill holes in, cut or heat the main structural elements of the machine which have a direct impact on the machine operation safety.

1.5 TRANSPORT

The manure spreader is ready for sale completely assembled and does not require packing. Packing is only required for the machine's technical documentation and any extra equipment. The manure spreader is delivered to the user either transported on a vehicle or independently (towed), after being attached to a tractor.

1.5.1 TRANSPORT ON VEHICLE

Loading and unloading of the manure spreader from vehicle shall be conducted using loading ramp with the aid of an agricultural tractor. During work, adhere to the general principles of occupational health and safety (OHS) applicable to reloading work. Persons operating reloading equipment must have the qualifications required to operate these machines. The manure spreader must be properly hitched to the tractor according to the requirements specified in this Operator's Manual. The braking system must be started and checked before driving off or onto ramp.

The manure spreader should be attached firmly to the platform of the vehicle using straps or chains fitted with a tightening mechanism. Securing elements should be attached to the fixed structural elements of the manure spreader (longitudinal members, crossbars etc.). Use certified and technically reliable securing measures. Worn straps, cracked securing catches, bent or corroded hooks as well as elements damaged in a different way may be unsuitable for use. Carefully read the information contained in the Operator's Manual for the given securing measure. Chocks, wooden blocks or other objects without sharp edges should be placed under the wheels of the manure spreader to prevent it from rolling. Manure spreader wheel blocks must be nailed to the boards of the vehicle load platform or secured in another manner preventing their movement. The number of securing elements (cables, straps, chains

and stays etc.) and the force necessary for their tensioning depend on such factors as the manure spreader weight, the carrying vehicle design, speed of travel and other conditions. For this reason it is impossible to define the securing plan precisely. A correctly secured manure spreader does not change its position with regard to the carrying vehicle. The securing elements must be selected according to the instructions of the Manufacturer of these elements. In case of doubt apply a greater number of securing straps in order to immobilise the machine. If necessary, sharp edges of the manure spreader should be protected to prevent damage to the securing elements during transport.

ATTENTION



When being road transported on a motor vehicle the manure spreader must be mounted on the vehicle's platform in accordance with the transport safety requirements and the regulations.

Driver of the vehicle should be particularly careful during travel. This is due to the vehicle's centre of gravity shifting upwards when loaded with the machine.

Use only certified and technically reliable securing measures. Carefully read the information contained in the Operator's Manuals for the given securing measures.

During reloading work, particular care should be taken not to damage parts of the machine's equipment or the paint coating. The tare weight of the manure spreader in condition ready for travel is given in table (3.1).



DANGER

Incorrect use of securing measures may cause an accident.

1.5.2 INDEPENDENT TRANSPORT BY THE USER

In the event of independent transport by the user after purchase of the manure spreader, the user must read the Operator's Manual of the manure spreader and adhere to the recommendations contained therein. Independent transport involves towing the manure spreader using own agricultural tractor. During transport adjust travel speed to the prevailing road conditions, but do not exceed the maximum design speed.



ATTENTION

Before transporting independently, the tractor driver must carefully read this Operator's Manual and observe its recommendations.

1.6 ENVIRONMENTAL HAZARDS

A hydraulic oil leak constitutes a direct threat to the natural environment owing to its limited biodegradability. Because of the low solubility of oil in water, it is not highly toxic to living organisms. An oil leak into water reservoirs may however lead to a reduction of the oxygen content. While carrying out maintenance and repair work, which involves the risk of an oil leak, this work should take place on an oil resistant floor or surface. In the event of oil leaking into the environment, first of all contain the source of the leak, and then collect the leaked oil using available means. Remaining oil should be collected using sorbents, or by mixing the oil with sand, sawdust or other absorbent materials. The oil pollution, once gathered up, should be kept in a sealed, marked, hydrocarbon resistant container. The container should be kept away from heat sources, flammable materials and food.



DANGER

Used hydraulic oil or gathered remains mixed with absorbent material should be stored in a precisely marked container. Do not use food packaging for this purpose.

Used oil or oil unsuitable for further use due to loss of its properties should be stored in its original packaging in the conditions described above. Waste oil should be taken to the appropriate facility dealing with the re-use of this type of waste. Waste code: 13 01 10. Detailed information concerning hydraulic oil may be found on the product's Material Safety Data Sheet.



TIP

The hydraulic system of the manure spreader is filled with L-HL32 Lotos hydraulic oil.



ATTENTION

Waste oil should only be taken to the appropriate facility dealing with the re-use of this type of waste. Do NOT throw or pour oil into sewerage or water tanks.

1.7 WITHDRAWAL FROM USE

In the event of decision by the user to withdraw the machine from use, comply with the regulations in force in the given country concerning withdrawal from use and recycling of machines withdrawn from use. Before commencing dismantling, totally remove the oil from the hydraulic system and reduce air pressure completely in the pneumatic braking system (e.g. using air tank drain valve).

DANGER



During dismantling, use the appropriate tools, equipment (overhead travelling crane, crane or hoist etc.) and use personal protection equipment, i.e. protective clothing, footwear, gloves and eye protection etc.

Avoid contact of skin with oil. Do not allow used hydraulic oil to spill.

When spare parts are changed, worn out or damaged parts that cannot be reclaimed should be taken to a collection point for recyclable raw materials. Hydraulic oil should be taken to the appropriate facility dealing with the re-use of this type of waste.

SECTION

2

SAFETY ADVICE

2.1 BASIC SAFETY RULES

2.1.1 USE OF MANURE SPREADER

- Before using the machine, the user must carefully read this Operator's Manual and the Operator's Manual of the PTO shaft. During use all the recommendations laid down in this Operator's Manual should be observed.
- If the information stated in the Operator's Manual is difficult to understand, contact a seller, who runs an authorised technical service on behalf of the Manufacturer, or contact the Manufacturer directly.
- Careless and improper use and operation of the manure spreader, and non-compliance with the recommendations given in this operator's Manual is dangerous to your health.
- Non-compliance with the safety rules of this Operator's Manual can be dangerous to the health and life of the operator and others.
- Be aware of the existence of a residual risk, and for this reason the fundamental basis for using this manure spreader should be the application of safety rules and sensible behaviour.
- The machine must never be used by persons, who are not authorised to drive agricultural tractors, including children and people under the influence of alcohol or other drugs.
- The machine must not be used for purposes other than those for which it is intended. Anyone who uses the machine other than the way intended takes full responsibility for himself for any consequences of this use.
- Do NOT place hand near and do NOT approach working elements of the machine.
- Any modification to the manure spreader frees the manufacturer from any responsibility for damage or detriment to health which may arise as a result.
- The machine can only be stood on when it is absolutely motionless and the tractor engine is switched off.

2.1.2 HITCHING AND UNHITCHING THE MANURE SPREADER, LOADING THE LOAD BOX

- The manure spreader should be hitched to and transported with only such an agricultural tractor which fulfils all the requirements of the Manufacturer (minimum tractor power demand, required tractor hitch etc.) – see table (1.2) *AGRICULTURAL TRACTOR REQUIREMENTS*.
- Before hitching the manure spreader make certain that oil in external hydraulic system of tractor may be mixed with the hydraulic oil of the manure spreader.
- Be especially careful when hitching the machine to the tractor.
- When hitching, there must be nobody between the manure spreader and the tractor.
- Before each use of the manure spreader check its technical condition. In particular, check the technical condition of the hitch systems and axle systems of the manure spreader and tractor, the technical condition of the brake system and indicator lights and tension of feeding chain.
- While connecting the manure spreader to the tractor, use only the hitch designed for single axle trailers. After completing the hitching of the machines check the safety of the hitch Carefully read the tractor Operator's Manual.
- The manure spreader may only be used when all the safety guards and other protective elements are technically sound and correctly positioned.
- The manure spreader disconnected from the tractor must be immobilised with the parking brake. If the machine is positioned on a slope or elevation it should be additionally secured against moving by placing chocks under the machine's wheels.
- Do NOT climb on load box during loading and unloading.
- Before loading make certain that there are no stones, tools or other objects in the load box and on the adapter's discs.
- Loading work should be conducted by person having experience in this type of work.

- Loading of manure spreader may only take place when the machine is positioned on level and hard surface and connected to tractor. Tractor and manure spreader must be placed to drive forwards.
- The load must be arranged in such a way that it does not threaten the stability of the manure spreader and does not hinder driving.
- Consider large vertical load of the drawbar and tractor hitch when loading the manure spreader.

2.1.3 TRANSPORTING THE MACHINE

- During travel on public roads comply with the road traffic regulations and transport regulations in force in a given country, in which the manure spreader is used.

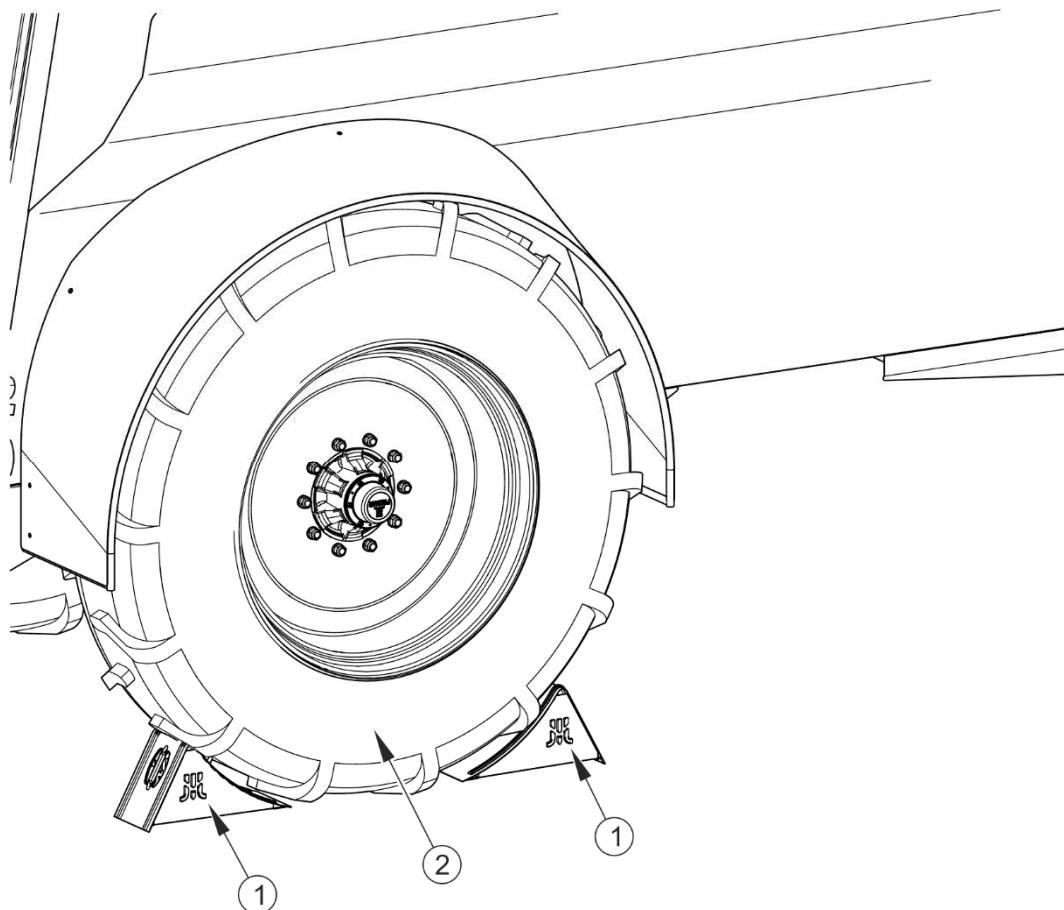

FIGURE 2.1 Method of placing chocks

(1) wheel chock, (2) axle wheel

- Chocks (1) should be placed only under one wheel (one in front of the wheel, the other behind the wheel - figure(2.1)).
- Before driving off make certain that the manure spreader is correctly hitched to the tractor.
- Before driving off check braking ability of the tractor-manure spreader set.
- Do not carry people or animals on the manure spreader.
- Before driving off check that the parking brake is released, the braking force regulator is positioned in the proper position (refers to pneumatic systems with a manual three position regulator).
- Remember that the tractor front axle is unloaded and the tractor is more difficult to steer because of vertical drawbar load.

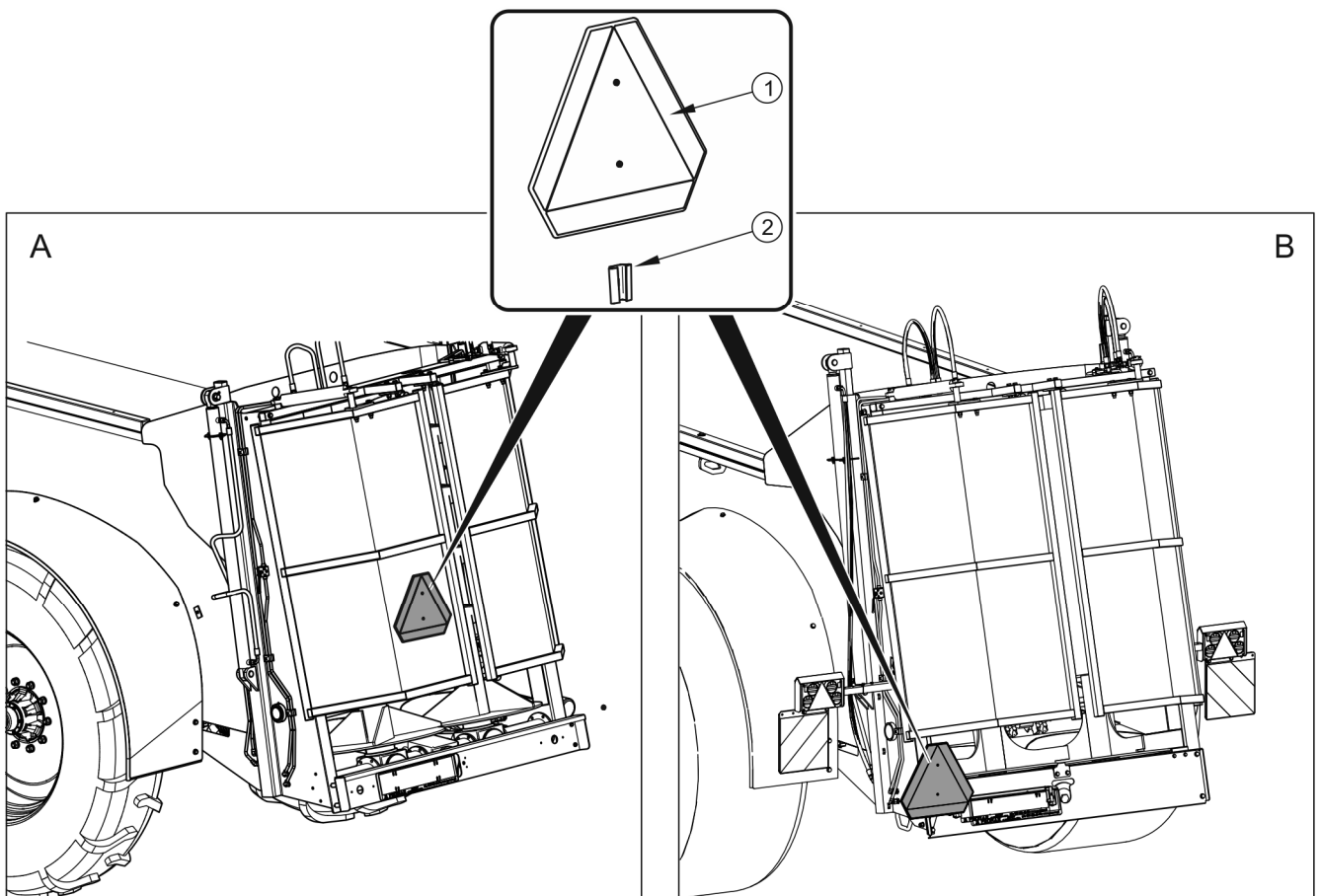

FIGURE 2.2 Location of the slow-moving vehicle warning sign

(A) version standard, (B) version EU, (1) slow-moving vehicle warning sign, (2) attachment point

- Place the slow-moving vehicle warning sign in the rear section of the machine – figure (2.2). The slow-moving vehicle warning sign (1) should be placed in the special attachment point (2).
- Exceeding the permissible carrying capacity of the manure spreader may lead to damage to the machine, loss of stability while driving, scattering of the load and also threaten the safety of traffic. The braking system is designed for the gross weight of the manure spreader, exceeding the weight limit causes drastic reduction of the main brake efficiency.
- Adjust travel speed to the prevailing road conditions, manure spreader load and road traffic regulations limits. If possible avoid travelling on uneven terrain and unexpected corners.
- Load the manure spreader in such a manner as to ensure that the road is not soiled with transported material while driving on public roads.
- The machine must NOT be left unsecured. The manure spreader disconnected from the tractor must be immobilised with parking brake and secured against rolling away with wheel chocks placed under the wheels.
- While driving on public roads the manure spreader and the tractor must be fitted with a certified or authorised reflective warning triangle.
- When transporting the load on the manure spreader without the slide gate and/or tailgates, secure the load against falling out backwards. The load must be secured so that it cannot move or fall over.

2.1.4 HYDRAULIC SYSTEM AND PNEUMATIC SYSTEM

- The hydraulic system is under high pressure when operating.
- Use the hydraulic oil recommended by the Manufacturer. Never mix two types of oil.
- Regularly check the technical condition of the connections and the hydraulic and pneumatic conduits. There must no oil or air leaks.
- In the event of malfunction of the hydraulic or pneumatic system, do not use the machine until the malfunction is corrected.

- When connecting the hydraulic conduits to the tractor, make sure that the hydraulic system of the tractor and manure spreader is not under pressure. If necessary, reduce residual pressure in the system.
- Before beginning repair work on hydraulic or pneumatic systems reduce oil or air pressure.
- In the event of injuries being caused by pressurised hydraulic oil, contact a doctor immediately. Hydraulic oil may find its way under the skin and cause infections.
- Rubber hydraulic conduits must be replaced every 4 years regardless of their technical condition.

2.1.5 OPERATION WITH PTO

- The manure spreader may only be connected to the tractor by appropriately selected PTO shaft recommended by the Manufacturer.
- Before using the machine the user should thoroughly acquaint himself with the PTO shaft Operator's Manual and adhere to the recommendations contained in it.
- PTO shaft may be connected and disconnected only if:
 - ⇒ PTO is disengaged,
 - ⇒ tractor engine is switched off,
 - ⇒ parking brake is applied,
 - ⇒ ignition key is removed from ignition switch.
- Before starting the tractor with the coupled manure spreader, make sure that PTO drive in the tractor is disconnected.
- PTO shaft must be equipped with shields. Do NOT use the shaft with damaged or missing guards.
- Install PTO shaft according to guidelines presented in the Operator's Manual of PTO shaft.
- The PTO shaft has markings on the casing, indicating which end of the shaft should be connected to the tractor. Torque limiter (if used) or unidirectional clutch ("freewheel") must be always installed on the machine side.

- Protect the PTO shaft shields against turning with the aid of small chains, which should be secured to a fixed structural element of the manure spreader.
- After connecting shaft ensure that it is correctly and safely connected to the tractor and to the manure spreader.
- Before activating the manure spreader, always ensure that all the safety guards are in good condition and in place. Damaged or incomplete sub-assemblies must be exchanged for original new ones.
- Do NOT wear loose clothing, straps or whatever that may become wrapped round the rotating drive shaft. Contact with rotating PTO shaft may cause severe injuries.
- When working in limited visibility conditions, use the tractor's working lights to illuminate the PTO shaft and its vicinity.
- During transport the shaft must be stored in the horizontal position to avoid damage to safety guards or other protection elements.
- When using the manure spreader and power take-off shaft, do not use PTO rotation speed other than specified in table (3.1). Do NOT overload shaft and manure spreader and do NOT engage the clutch suddenly. Before starting PTO shaft, make certain that the PTO rotation direction is correct.
- Do NOT go over and under the shaft or stand on it during work and also when the manure spreader is parked.
- Never use a damaged PTO shaft, it may cause an accident. A damaged shaft must be repaired or replaced.
- Disconnect the shaft drive each time it is not necessary to drive the machine or when the tractor and manure spreader are at an unsuitable angle to each other.
- Make sure that shaft is covered when travelling on an uneven terrain.
- Disconnected PTO shaft should be placed in the specifically prepared holder.
- Do NOT use the securing chains to support the shaft while machine is parked or when transporting the spreader.

2.1.6 MACHINE OPERATION

- Staying in the material spreading area is forbidden due to danger which may be caused by stones, pieces of wood etc. contained in the material.
- Take particular care while spreading material near people and animals.
- Before starting work, always check condition of elements that fix disintegrating knives of spreader unit.
- Take particular care while spreading material near roads and other vehicles.

2.1.7 CLEANING, MAINTENANCE AND REPAIRS

- Repair, maintenance and cleaning work should be carried out with the tractor engine turned off and the ignition key removed.
- Manure spreader, spreader unit in particular, should be kept clean.
- Remove the remains of manure from the manure spreader each time after finished work.
- Before climbing on to the manure spreader's load box, make sure that unauthorised persons do not have access to the tractor, disconnect PTO shaft and disconnect hydraulic system conduits from the tractor.
- The manure spreader must be absolutely motionless, the tractor engine must be switched off and particular care must be taken while climbing on to the manure spreader's load box.
- During the warranty period, any repairs may only be carried out by Warranty Service authorised by the manufacturer. After the expiry of the warranty period it is recommended that possible repairs to the machine be performed by specialised workshops.
- In the event of any fault or damage whatsoever, do not use the manure spreader until the fault has been corrected.
- During work, use the proper, close-fitting protective clothing, gloves and appropriate tools.
- Servicing and repair work should be carried out in line with the general principles of workplace health and safety. In the event of injury, the wound must be

immediately cleaned and disinfected. In the event of more serious injuries, seek a doctor's advice.

- Regularly check the condition of the bolt and nut connections.
- Should it be necessary to change individual parts, use only original parts. Non-adherence to these requirements may put the user and other people's health and life at risk, and also damage the manure spreader and invalidate the warranty.
- Before welding or electrical work, the manure spreader should be disconnected from the power supply.
- The paint coating should be cleaned off before beginning welding work. Burning paint fumes are poisonous for people and animals. Welding work should be carried out in a well lit and well ventilated space.
- During welding work pay attention to flammable or fusible elements (parts of the pneumatic, electric and hydraulic systems, plastic parts). If there is a risk that they will catch fire or be damaged, they should be removed before commencing welding work.
- In the event of work requiring the manure spreader to be raised, use properly certified hydraulic or mechanical lifts for this purpose. After lifting the manure spreader, stable and durable supports must also be used. Do NOT carry out work under the manure spreader, which has only been raised with the lift jack.
- The lifted manure spreader must not be supported using fragile elements (bricks, hollow bricks or concrete blocks).
- After completing work associated with lubrication, remove excess oil or grease.
- Do not repair control valve, brake cylinders and braking force regulator by yourself.
- After changing the hydraulic oil, the used oil should be properly disposed of.
- Check the tyre pressure regularly.
- When working with tyres, the manure spreader should be immobilised with parking brake and secured against rolling by placing under the wheels the chocks delivered with the spreader. Wheel may be taken off the manure spreader axle only when the manure spreader is not loaded.

- Repair work on the wheels or tyres should be carried out by persons trained and entitled to do so. This work should be carried out using appropriate tools.
- Each time a wheel is fitted, tighten all nuts after the first 10 working hours and then check proper tightening of nuts every 50 working hours. The above actions should be repeated each time a wheel has been removed from the wheel axle.

2.2 DESCRIPTION OF RESIDUAL RISK

Pronar Sp. z o. o. in Narew has made every effort to eliminate the risk of accidents. There is, however, a certain residual risk, which could lead to an accident, and this is connected mainly with the actions described below:

- using manure spreader for purposes other than those described in the Operator's Manual,
- being between the tractor and the manure spreader while the engine is running and when the machine is being attached,
- operation of the manure spreader by persons under the influence of alcohol or other intoxicating substances,
- oil leaks and sudden movement of elements resulting from line cracking,
- operation of manure spreader by an authorised person,
- being on the machine during work or transport,
- cleaning, maintenance and inspection of the mechanisms of the manure spreader connected with tractor using PTO shaft, when the tractor engine is switched on,
- using unreliable PTO shaft,
- making modifications to the machine without the consent of the Manufacturer,
- exceeding permissible travel speed,
- presence of persons or animals in areas invisible from the driver's position.

The residual risk may be kept to a minimum by following the recommendations below:







- prudent and unhurried operation of the machine,



- sensible adherence to the remarks and recommendations contained in the Operator's Manual,
- maintaining safe distance from forbidden or dangerous places,
- a ban on being on the machine when it is operating,
- carrying out repair and maintenance work by persons trained to do so,
- using suitable protective clothing,
- ensuring unauthorised persons have no access to the machine, especially children,
- making certain that there are no persons in the driver's blind spots (particularly while reversing).





2.3 INFORMATION AND WARNING DECALS

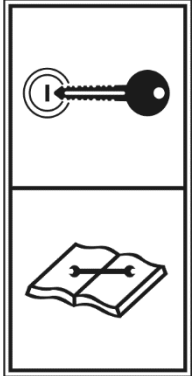

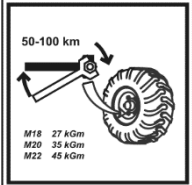
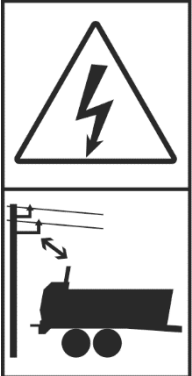



The manure spreader is marked with information and warning decals referred to in table (2.1). The symbols are positioned as presented in figure (2.3). Throughout the time it is in use, the user of the machine is obliged to take care that notices and warning and information symbols located on the manure spreader are clear and legible. In the event of their destruction, they must be replaced with new ones. Safety decals can be purchased from the Manufacturer of the manure spreader or your PRONAR dealer. New assemblies, changed during repair, must be labelled once again with the appropriate safety signs. During cleaning do not use solvents which may damage the coating of information label stickers and do not subject them to strong water jets.

TABLE 2.1 Information and warning decals

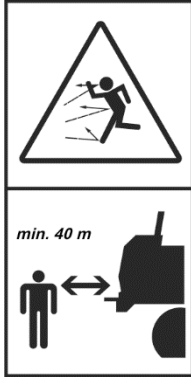
ITEM	SAFETY SYMBOL	DESCRIPTION
1		<p>Machine symbol. 523N-00000004</p>
1		<p>Machine symbol. 523N-00000005</p>
1		<p>Machine symbol. 539N-00000001</p>
1		<p>Machine symbol. 535N-00000001</p>
1		<p>Machine symbol. 544N-00000001</p>
2		<p>Caution! Before starting work, carefully read the Operator's Manual. 70RPN-00.00.00.04</p>

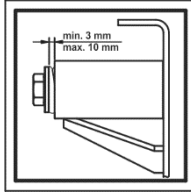
ITEM	SAFETY SYMBOL	DESCRIPTION
3		<p>Danger of inadvertent starting or rolling of the machine.</p> <p>Before beginning servicing or repairs, turn off engine and remove key from ignition</p> <p>70RPN-00.00.00.05</p>
4		<p>Grease according to the recommendations in the Operator's Manual .</p> <p>104RPN-00.00.00.04</p>
5		<p>Check the condition of the bolt and nut connections of the wheel axles.</p> <p>104RPN-00.00.00.06</p>
6	<p>Łączenie tylko z zaczepem do przyczep jednoosiowych</p>	<p>Use exclusively the hitch for single axle trailers.</p> <p>37RPN-00.00.00.02</p>
7		<p>Caution! Danger of electric shock.</p> <p>Take particular care while working near electric power lines.</p> <p>70RPN-00.00.00.03</p>

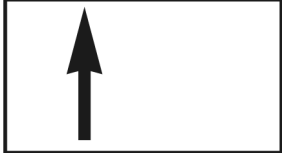
ITEM	SAFETY SYMBOL	DESCRIPTION
8		<p>Caution!</p> <p>Do not stand on the chain conveyor if the tractor engine is running and PTO shaft is engaged</p> <p>70RPN-00.00.00.08</p>
9		<p>Caution! Danger of crushing.</p> <p>Keep a safe distance from the rotating spreading discs.</p> <p>70RPN-00.00.00.09</p>
10		<p>Caution! Danger of crushing.</p> <p>Do not place hands near working elements of the chain conveyor.</p> <p>70RPN-00.00.00.10</p>
11		<p>Grease according to the recommendations in the Operator's Manual .</p> <p>70RPN-00.00.00.22</p>
12		<p>PTO RPM</p> <p>75RPN-00.00.00.04</p>

ITEM	SAFETY SYMBOL	DESCRIPTION
13		<p>Beware of thrown out objects.</p> <p>Thrown out objects endanger the whole body. Keep a safe distance from the spreader unit, minimum 40 metres.</p> <p>153RPN-00.00.00.10</p>
14		<p>Before climbing on the ladder in order to perform maintenance or repair inside the load box, turn off engine and remove key from ignition. Secure tractor against unauthorised access.</p> <p>29RPN-00.00.030</p>
15		<p>Check the chain conveyor tension.</p> <p>153N-00000014</p>
16		<p>Information decal identifying the hydraulic brake connection⁽¹⁾.</p> <p>29RPN-00.00.028</p>
17		<p>Flow direction of hydraulic oil in the conveyor drive hydraulic conduits⁽¹⁾</p> <p>70RPN-12.00.00.09</p>
18		<p>High pressure fluid – injection into body.</p> <p>535N-00000009</p>

ITEM	SAFETY SYMBOL	DESCRIPTION
19		Wait until all machine components have completely stopped before touching them. 535N-00000008

⁽¹⁾ - not shown in figure, the decal is placed close to the hydraulic plugs

Numbers in the item column correspond to labels in figure (2.3).

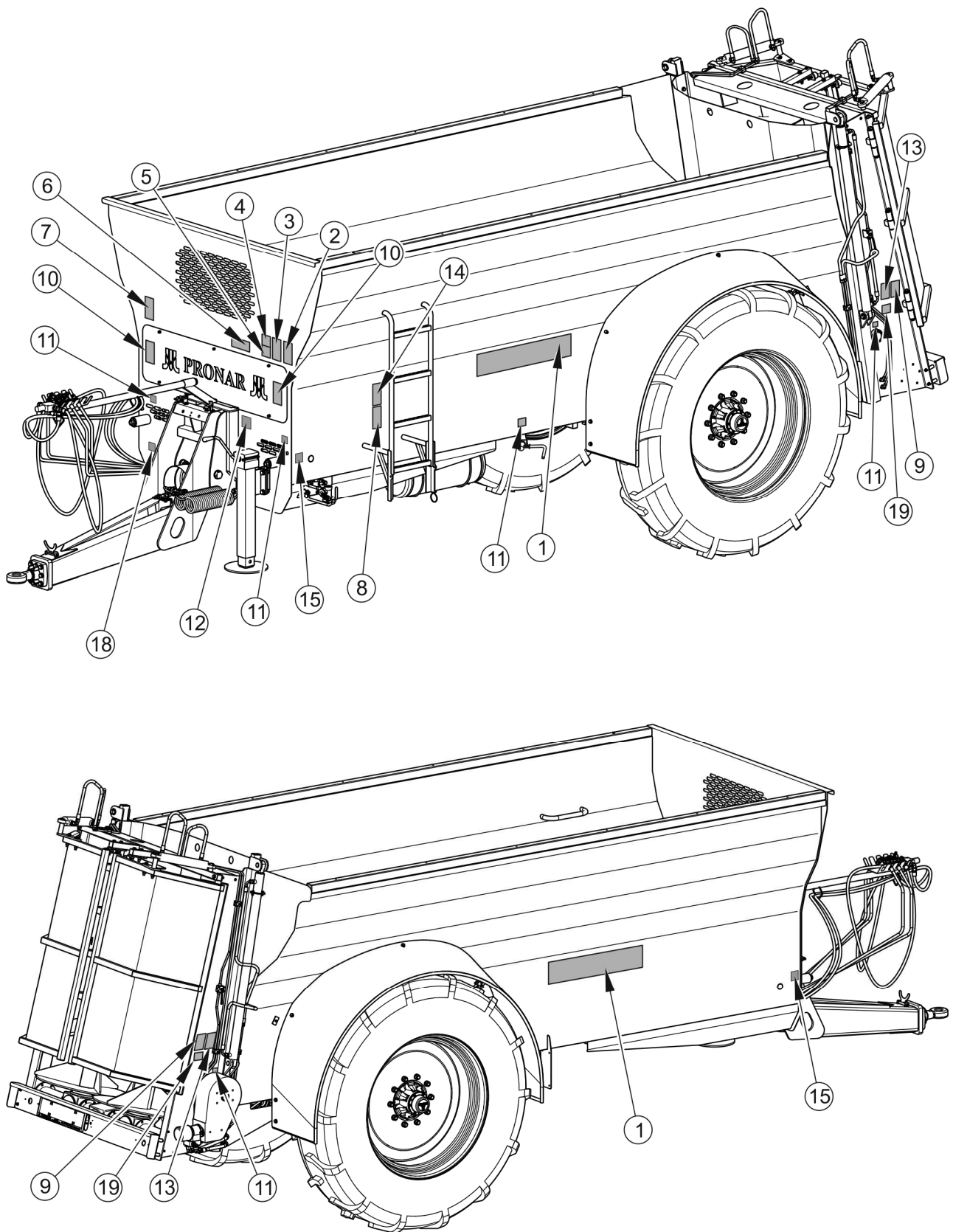

FIGURE 2.3 Locations of information and warning decals

SECTION

3

**DESIGN AND
OPERATION**

3.1 TECHNICAL SPECIFICATION

TABLE 3.1 Technical specification of manure spreader NV161/1, NV161/2, NV161/3

CONTENTS	UNIT	NV161/1	NV161/2	NV161/3
Manure Spreader dimensions				
Total length	mm	7,250	7,250	7,330
Total width	mm	2,540	2,540	2,760
Total height	mm	2,560	2,610	2,700
Wheel track	mm	2,050	2,050	2,170
Internal load box dimensions				
Length	mm	4,500	4,500	4,500
Width (top / bottom)	mm	2,000/1,500	2,000/1,500	2,000/1,500
Height	mm	1,160	1,360	1,500
Technical specification				
Maximum gross weight (*)	kg	10,500	12,300	14,200
Carrying capacity (*)	kg	6,750	8,490	10,240
Tare weight	kg	3,750	3,810	3,960
PTO speed	RPM	540	540	1,000
Tractor power demand (minimum)	hp \ kW	70 / 51.5	80 / 58.8	90 / 66.2
Cargo capacity	m ³	9.1	10.7	11.8
Load surface	m ²	6.7	6.7	6.7
Maximum spread width	m	8-12	8-12	8-12
Maximum design speed (version standard)	km / h	30	30	30
Maximum speed (version EU)	km / h	25	25	25
Other information				
Loading height	mm	2,250	2,500	2,430
Electrical system voltage	V	12	12	12
Drawbar eye load	kg	2,000	2,500	3,000
Tyre dimensions	-	18.4 – 34	18.4 – 38	23.1 – 26
Type of spreader unit	-	Vertical 2-beater	Vertical 2-beater	Vertical 2-beater

(*) - Parameters depending on the legal restrictions on the target market, may differ from that indicated.

TABLE 3.2 Technical specification of manure spreader NV161/4, NV161/5

CONTENTS	UNIT	NV161/4	NV161/5
Manure Spreader dimensions			
Total length	mm	7,900	8,580
Total width	mm	3,090	2,950
Total height	mm	2,270	2,800
Wheel track	mm	2,340	2,320
Internal load box dimensions			
Length	mm	5,000	5,680
Width (top / bottom)	mm	2,000/1,500	2,000/1,500
Height	mm	1,500	1,500
Technical specification			
Maximum gross weight (*)	kg	17,200	19,900
Carrying capacity (*)	kg	12,290	14,690
Tare weight	kg	4,910	5,210
PTO speed	RPM	1,000	1,000
Tractor power demand (minimum)	hp \ kW	100 / 73.5	120 / 88.2
Cargo capacity	m ³	13.1	14.9
Load surface	m ²	7.5	8.5
Maximum spread width	m	8-12	8-12
Maximum design speed (version standard)	km / h	30	30
Maximum speed (version EU)	km / h	25	25
Other information			
Loading height	mm	2,600	2,700
Electrical system voltage	V	12	12
Drawbar eye load	kg	3,000	4,000
Tyre dimensions	-	750/65R26 (28.1R26)	650/75R32
Type of spreader unit	-	Vertical 2-beater	Vertical 2-beater

(*) - Parameters depending on the legal restrictions on the target market, may differ from that indicated.

3.2 MANURE SPREADER DESIGN

3.2.1 GENERAL DESIGN

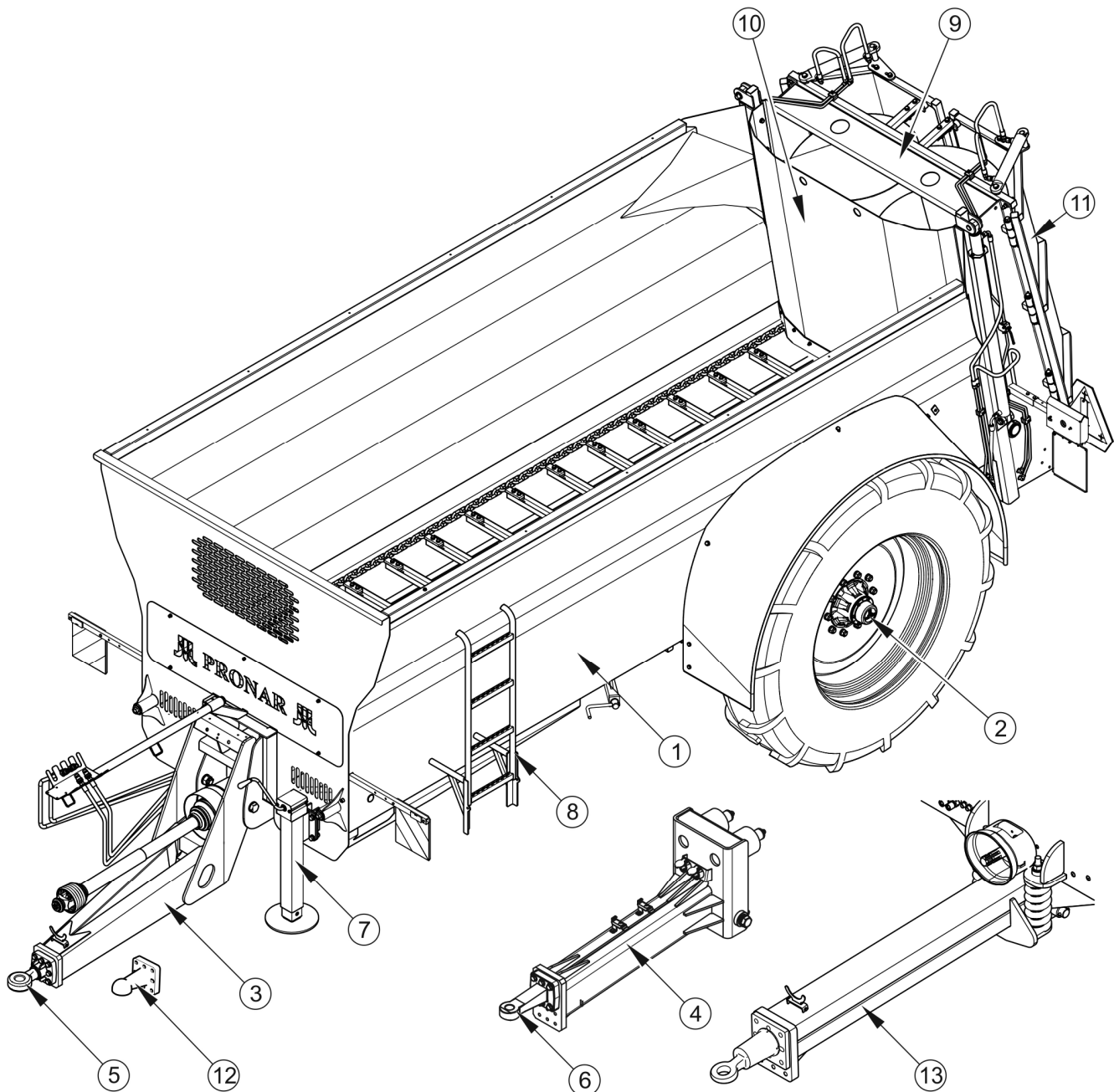

FIGURE 3.1 Manure spreader design

(1) load box (2) suspension system, (3) lower drawbar, (4) upper drawbar, (5) drawbar eye $\varnothing 50$, (6) fixed drawbar eye $\varnothing 40$, (7) support, (8) ladder, (9) two-beater vertical spreader unit, (10) load box slide gate, (11) tailgates, (12) ball drawbar eye, (13) drawbar with shock absorber (NV161/4 i NV161/5)

Manure spreader design is shown in figure (3.1). The manure spreader consists of a V-shaped monocoque load box (1) connected with rigid single axle system (2). The front wall has an inspection opening for controlling the load movement inside the load box. The axle system is equipped with large wheels which ensure low rolling resistance and facilitate travelling on wet ground and towing the manure spreader.

The support (7) is attached to the front wall of the load box. The support is used for supporting the manure spreader during parking, when the machine is not hitched to the tractor, and for adjusting the drawbar eye height when hitching the machine to tractor. The manure spreader is hitched to the tractor using the lower drawbar with shock absorber (3) and rotating drawbar eye (5) or ball drawbar eye (12). Optionally, the manure spreader can be equipped with upper drawbar (4) with fixed drawbar eye (6). NV161/4 manure spreader and NV161/5 manure spreader are equipped with drawbar with shock absorber (13).

Ladder (8) for climbing on top of the load box in order to perform cleaning or maintenance work is attached to the left wall of the load box. Wheel chocks are placed on the right wall. In the rear section of the manure spreader there is a PTO driven vertical spreader unit (9) with two wormshafts. Slide gate (10) can be additionally installed between the load box space and the spreader unit. The manure spreader can be additionally equipped with tailgates (11) to prevent load spill during transport and limit the manure spreading width during fieldwork.

3.2.2 FEEDING MECHANISM

The feeding mechanism in NV161/1 and NV161/2 and NV161/3 manure spreaders consists of transfer unit (1), tensioning unit (2) and drive unit (3) – figure (3.2) . The feeding mechanism in NV161/4 and NV161/5 manure spreaders consists of two transfer units (3), two tensioning units (2) and a drive unit (3) – figure (3.3).

The transfer unit consists of two chains (4) and scraping strips (5) bolted to the chains. The chains in the rear section of the manure spreader's load box are seated on cast iron gear wheels of drive mechanism shaft (3). The chains in the front section of the manure spreader's load box are seated on the front wheels of the tensioning unit (2).

The transfer mechanism is driven by hydraulic motor (6) which rotates drive mechanism shaft (3) via reduction gear (5). Chain wheels are mounted on the drive mechanism shaft. The rotating chain wheels cause shifting of transfer unit.

The chain tension is adjusted with tensioning bolts (8). The principle of conveyor speed adjustment is described in section 4.5.1 – figure (4.2), whereas the method of adjusting the tension of floor conveyor chains is described in section 5.7.

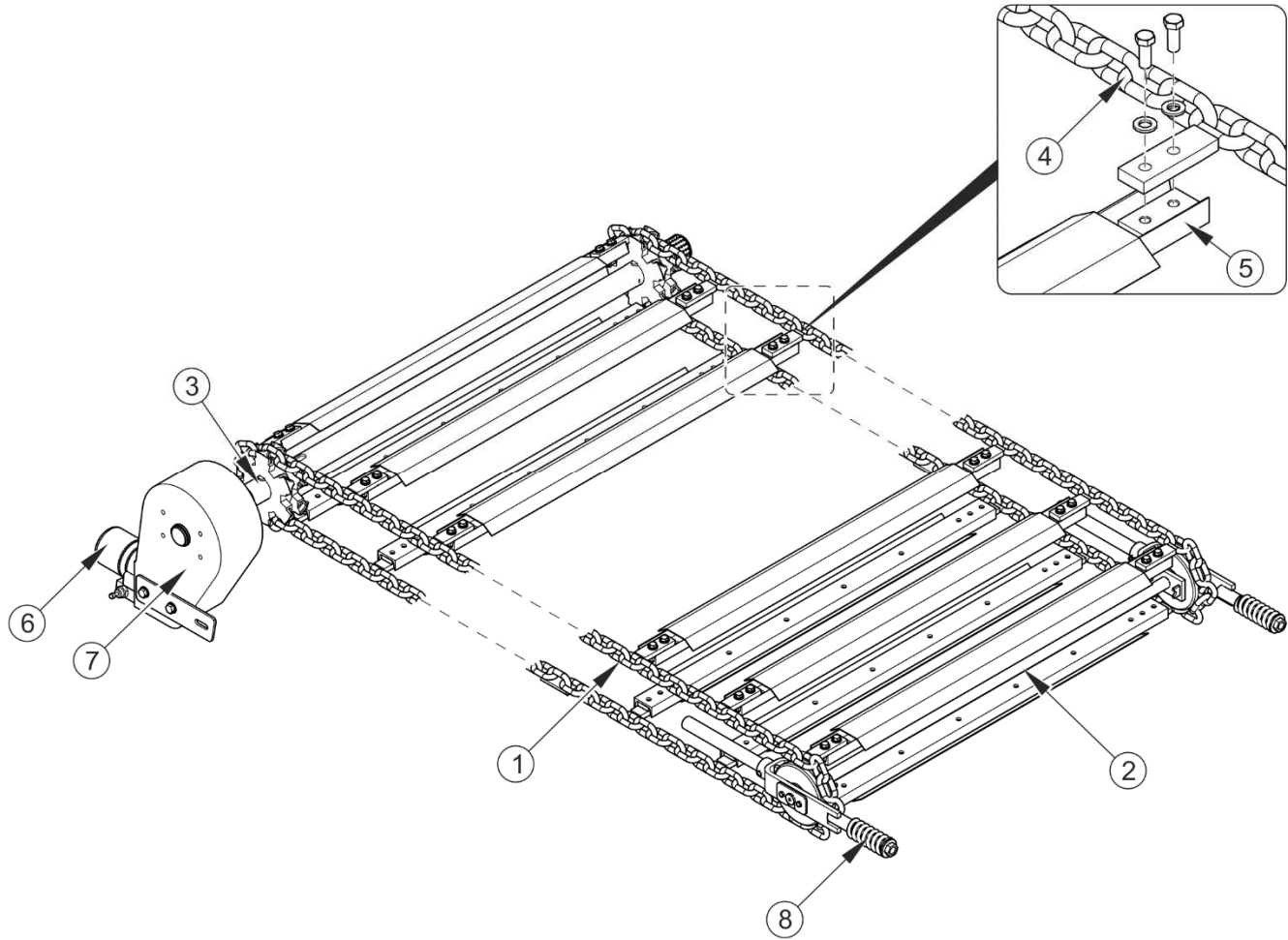

FIGURE 3.2 Feeding mechanism NV161/1, NV161/2, NV161/3

(1) transfer unit, (2) tensioning unit, (3) drive unit, (4) chain, (5) scraping strip, (6) hydraulic motor, (7) reduction gear, (8) tensioning bolt

ATTENTION



Movement direction of loaded feeding mechanism may be reversed only for a short time.

The feeding mechanism may be started only if the manure spreader's slide gate is raised (if it is included in the manure spreader's equipment). Otherwise, the manure spreader may be seriously damaged.

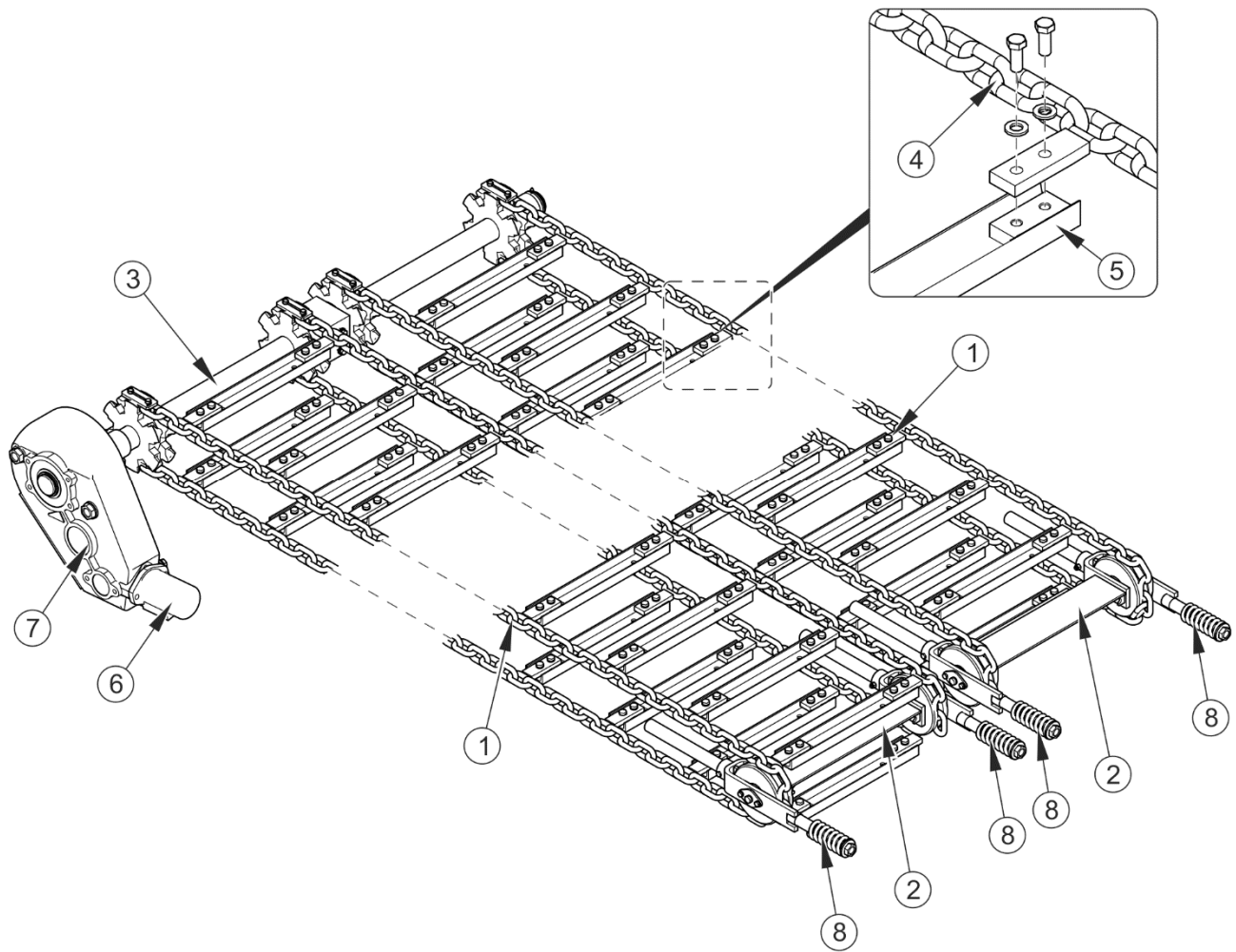

FIGURE 3.3 Feeding mechanism NV161/4, NV161/5

(1) transfer unit, (2) tensioning unit, (3) drive unit, (4) chain, (5) scraping strip, (6) hydraulic motor, (7) reduction gear, (8) tensioning bolt

3.2.3 HYDRAULIC SYSTEM OF FEEDING MECHANISM

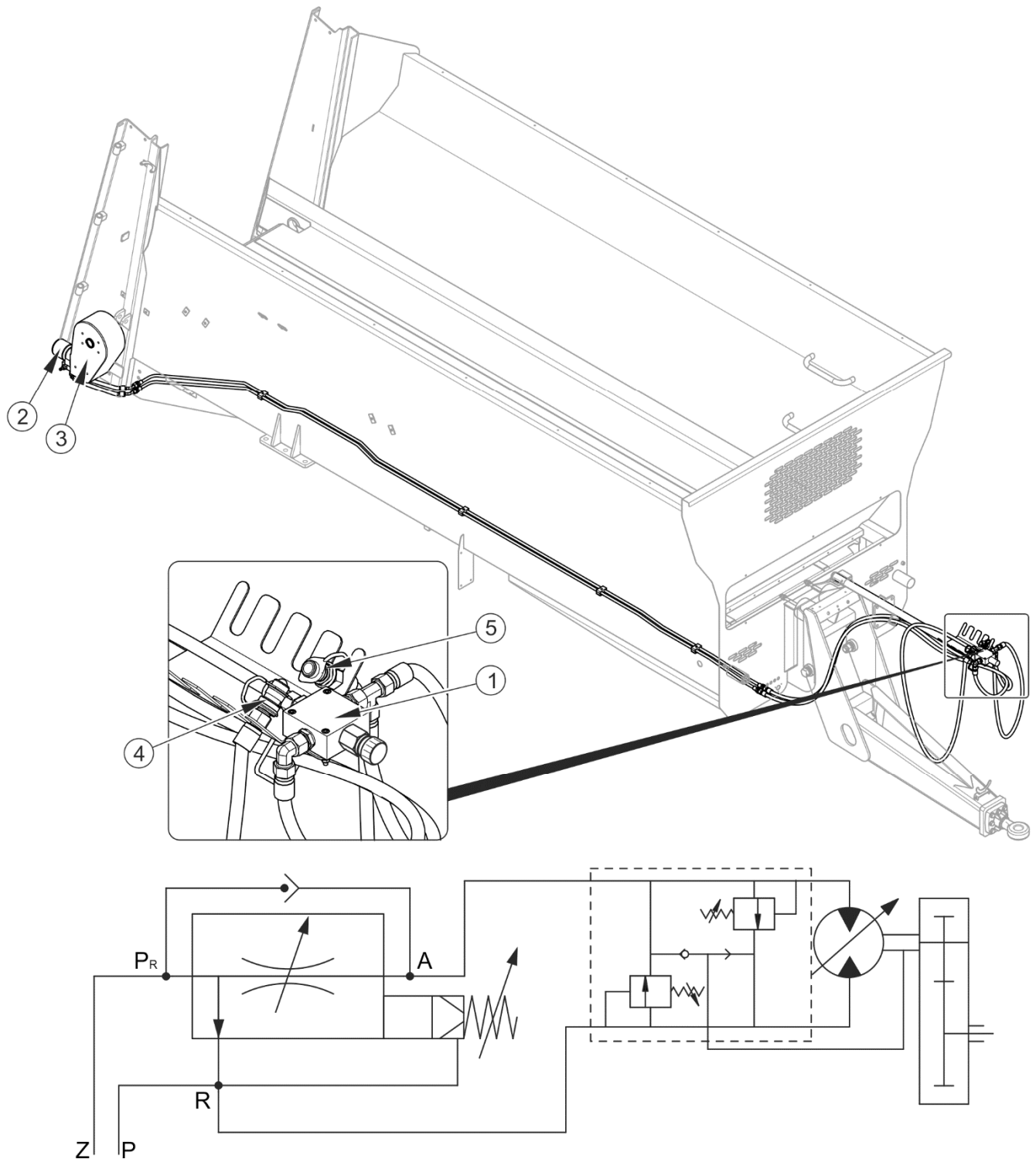

FIGURE 3.4 Design and diagram of hydraulic system of feeding mechanism

(1) flow rate regulator, (2) hydraulic motor, (3) reduction gear, (4) supply conduit, (5) return conduit, (Z) tractor supply, (P) tractor return

Design and diagram of hydraulic system of feeding mechanism is shown in figure (3.4). This system is used for controlling the floor conveyor. The hydraulic system is supplied from the tractor's external hydraulic system through hydraulic conduits (4) and (5). Conveyor movement direction depends on direction of hydraulic oil flow in the motor (2) which drives the feeding mechanism via reduction gear (3).



ATTENTION

In order to identify the conduits, labels with arrows are located near the connection plugs. The arrows indicate direction of hydraulic oil flow through hydraulic motor. Hydraulic conduits of the system are marked with black plugs.

The floor conveyor operation is controlled by means of the manifold in the tractor cab. Such a solution enables quick change of conveyor movement direction and shortens reaction time.

Conveyor movement speed is adjusted with flow regulator knob (1) within scale from 0 to 10. The flow regulator is installed on the outrigger in the front section of the manure spreader. The maximum flow rate (maximum conveyor speed) is achieved if flow regulator setting is 10, while the minimum flow rate is achieved if flow regulator setting is 0.

3.2.4 DRIVE TRANSMISSION

Spreader unit is driven by the drive transmission system whose design is shown in figure (3.5).

Torque is transmitted from the tractor PTO to the manure spreader's mechanisms via PTO shaft with shear bolt clutch (1). Torque from shaft (1) is transmitted to reduction gear of the spreader unit drive (4) via power transmission shaft (2) and PTO shaft with unidirectional overload clutch (3).



ATTENTION

For a given type of manure spreader, do NOT use PTO rotation speed other than specified in table 3.1.

If PTO shaft works at a different speed, rotation speed of spreading wormshafts will be insufficient and the drive will be at the risk of damage.

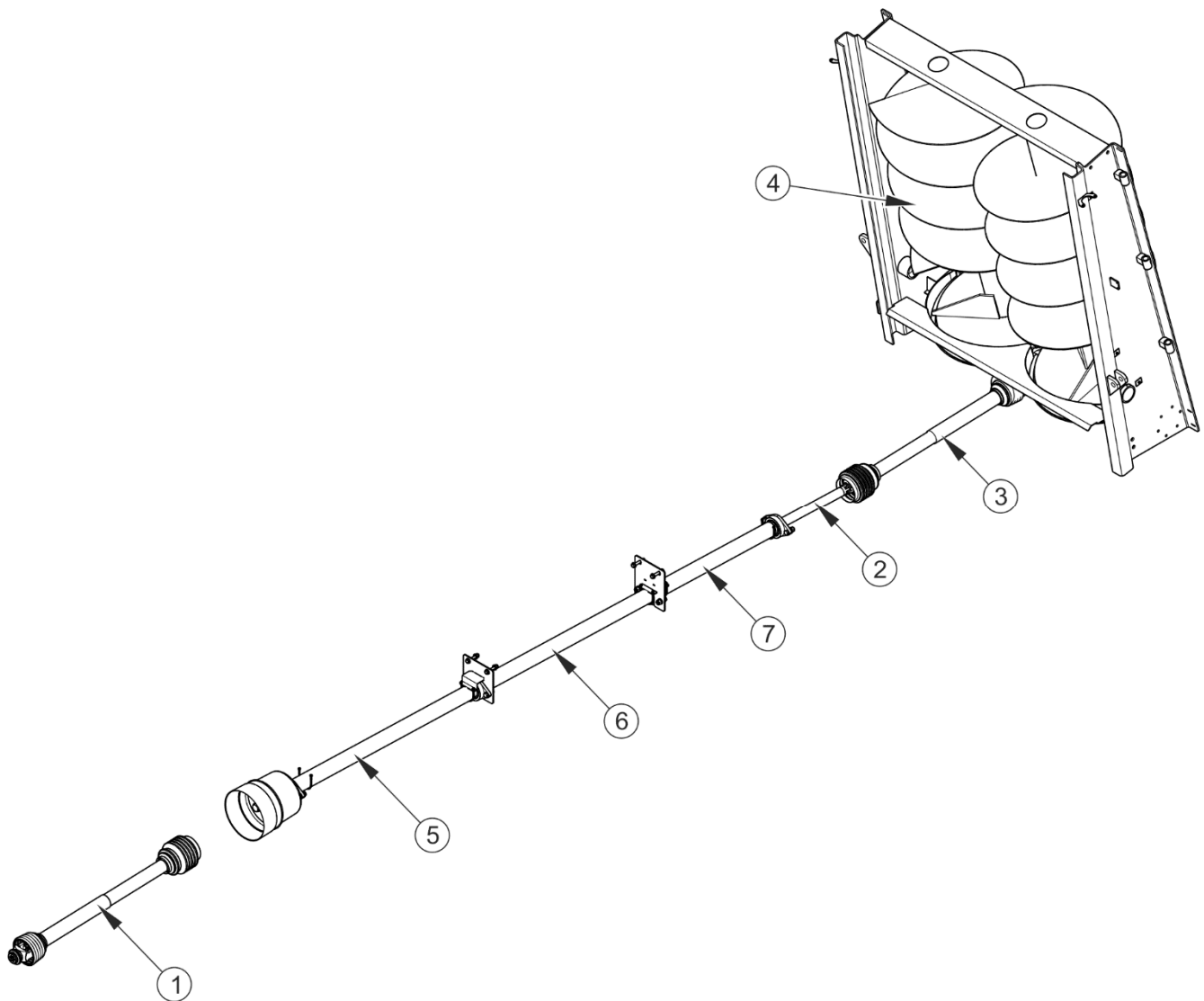

FIGURE 3.5 Drive transmission

(1) PTO shaft with shear bolt clutch, (2) power transmission shaft, (3) PTO shaft with unidirectional overload clutch, (4) spreader unit, (5), (6), (7) shaft shield

Drive transmission system is protected against damage by means of shear bolt clutch installed in PTO shaft (1) and with unidirectional overload clutch located on shaft (3).

3.2.5 TWO-BEATER VERTICAL SPREADER UNIT

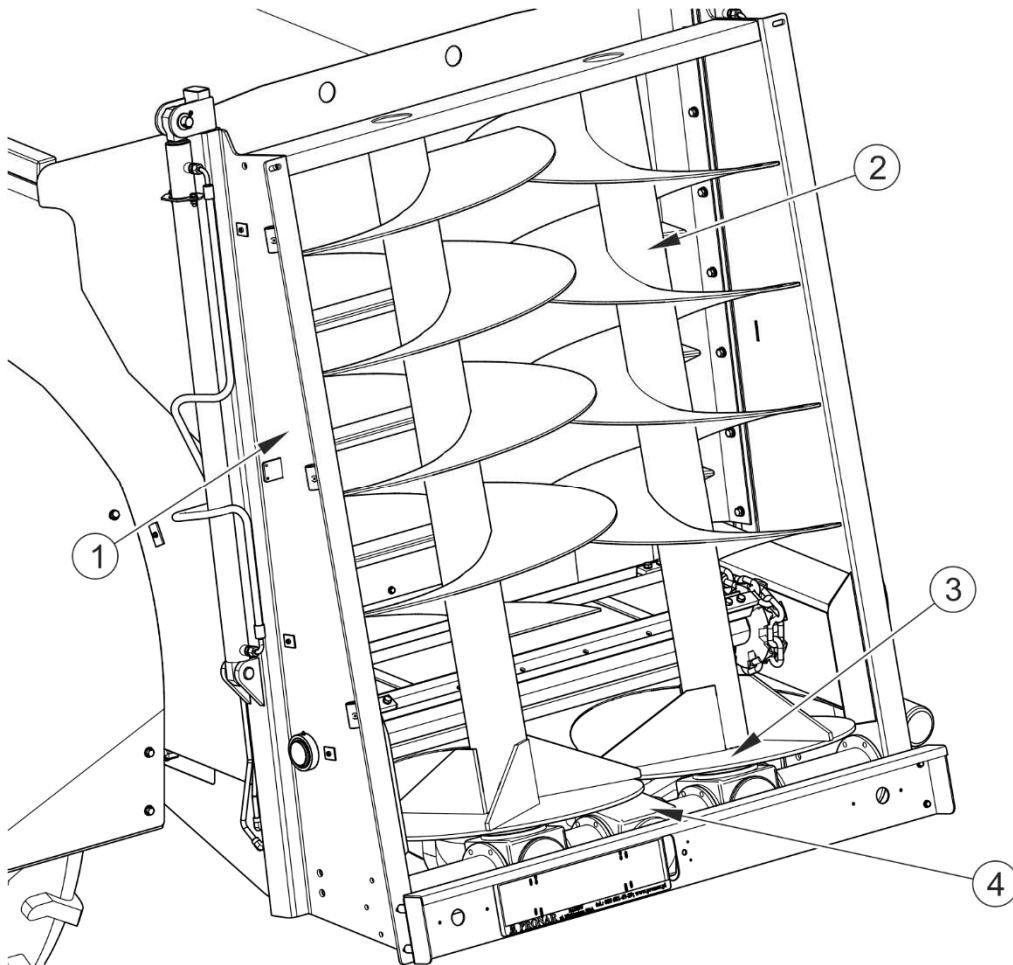

FIGURE 3.6 Two-beater vertical spreader unit

(1) side wall, (2) wormshaft, (3) spreading disk, (4) gear

The two-beater vertical spreader unit is used for disintegrating and spreading manure supplied by the floor conveyor. The unit is installed in the rear section of the manure spreader's load box. The unit is driven by drive transmission system and gear (4).

The spreader unit consists of side walls (1) and two vertical wormshafts (2). At the lower ends of the wormshafts there are disks (3) which ensure large widths of manure spreading. The wormshafts are equipped with bolted disintegrating knives (working tools). Rotating wormshafts disintegrate manure fed by the conveyor and spread it backwards.

3.2.6 TAILGATE OPENING HYDRAULIC SYSTEM

The tailgate hydraulic system is used for opening, closing and setting the manure spreader's tailgates in a required position. The hydraulic system is supplied with oil from the tractor external hydraulic system. The system is controlled from the tractor cab using the manifold lever. Pressurised oil is supplied through conduit (4) to hydraulic cylinders (2), which open the tailgates (1). The tailgates are closed by changing the position of the manifold lever in the tractor. Then, oil is pumped through conduit (5). Consequently, the cylinder rods are moved.

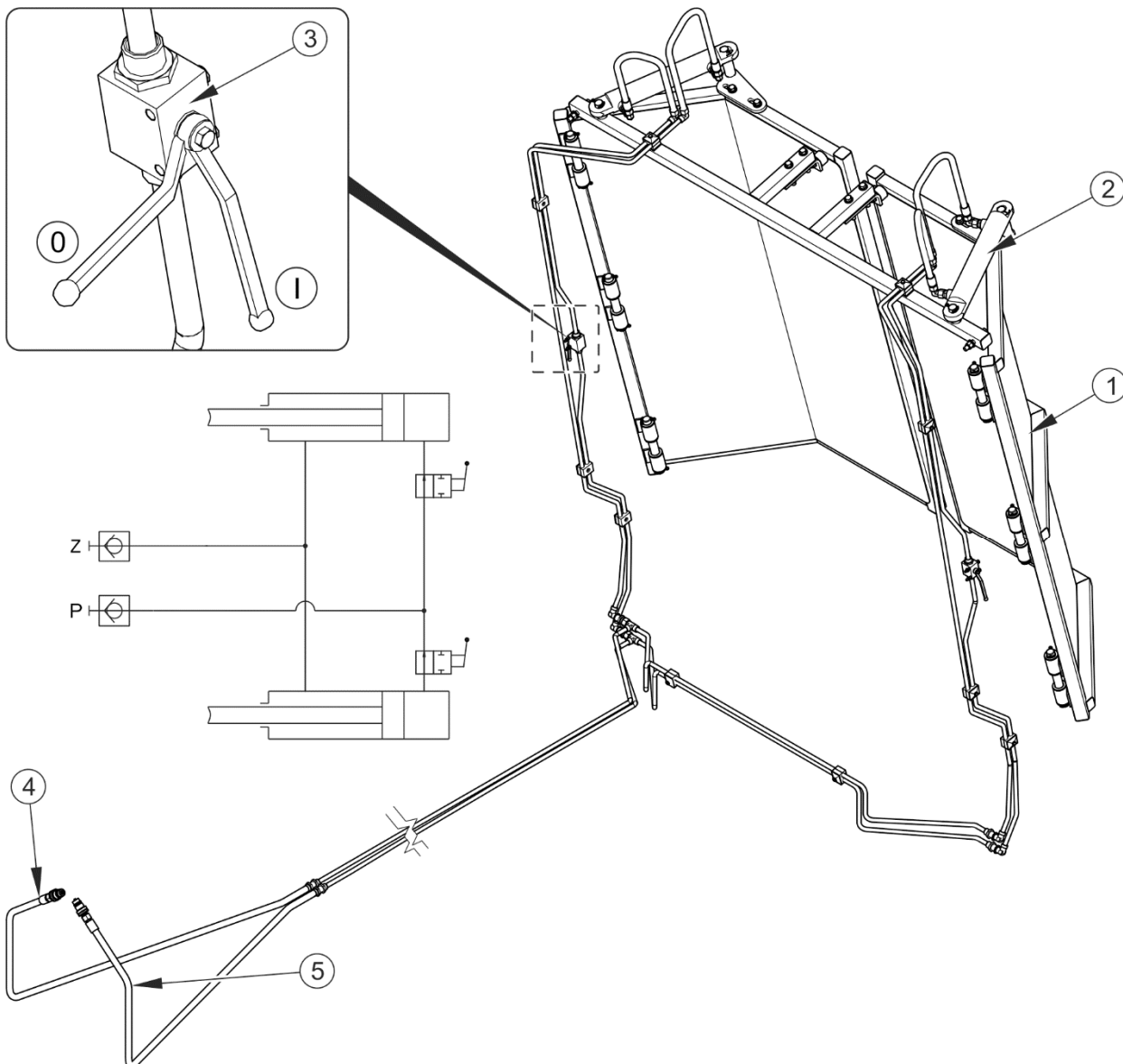

FIGURE 3.7 Design and diagram of the tailgate opening hydraulic system

(1) tailgate (2) hydraulic cylinder, (3) hydraulic valve, (4) return conduit, (5) supply conduit, (Z) supply, (P) return, (I) valve is open, (0) valve is closed

The system is equipped with two cut-off valves (3) which are used for protecting the tailgates against opening during transport and for independent setting of the tailgates to limit the spreading width during fieldwork.

ATTENTION



Hydraulic conduits of the tailgate opening system are marked with green plugs.

During maintenance work with the tailgates open, protect them from falling down by closing the cut-off valve and with a suitable mechanical support which is durable and stably mounted.

Take special care not to close or open the tailgates when they are locked by means of cut-off valves. Otherwise, hydraulic cylinders and/or tailgates may be damaged.

3.2.7 HYDRAULIC SYSTEM OF THE SLIDE GATE

Pronar manure spreader can be equipped with a load box slide gate. The slide gate is mounted in front of the spreader unit and it ensures safe transport of disintegrated materials (e.g. compost, peat) on public roads and ensures safe start of disintegrating wormshafts.

The load box slide gate is controlled hydraulically. This hydraulic system is supplied from the external hydraulic system of the tractor. The hydraulic cylinders opening and closing the slide gate are controlled by means of the manifold in the tractor cab. Oil pumped under pressure from the tractor external hydraulic system through a supply conduit (5) enters the flow divider (3) which separates the oil stream proportionally to the two hydraulic cylinders (2) causing the cylinder rods move steadily upwards to open the slide gate (1).

The slide gate is closed by changing the position of the manifold lever in the tractor. Then, oil is pumped through conduit (4) to cylinders (2). Consequently, the cylinder rods are moved downwards and the slide gate is closed.



ATTENTION

Hydraulic conduits of the slide gate's hydraulic system are marked with red plugs.

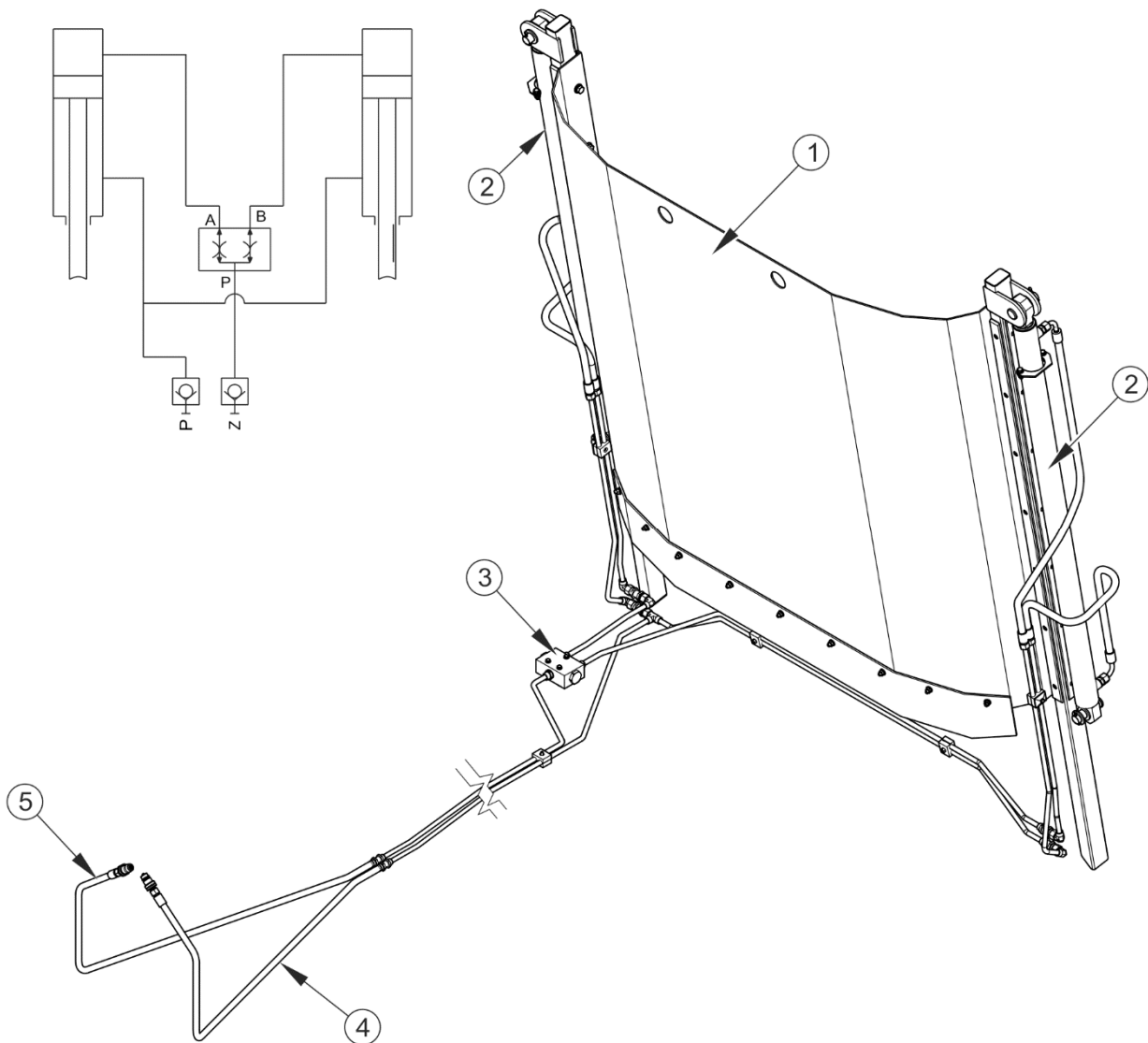

FIGURE 3.8 Design and diagram of the slide gate's hydraulic system

(1) slide gate, (2) hydraulic cylinder, (3) flow divider, (4) return conduit, (5) supply conduit, (Z) supply, (P) return

3.2.8 MAIN BRAKE

The manure spreader can be equipped with one of the three types of main brake system:

- single conduit pneumatic system - figure (3.9),
- double conduit pneumatic system - figure (3.10).
- Hydraulic braking system – figure (3.11).

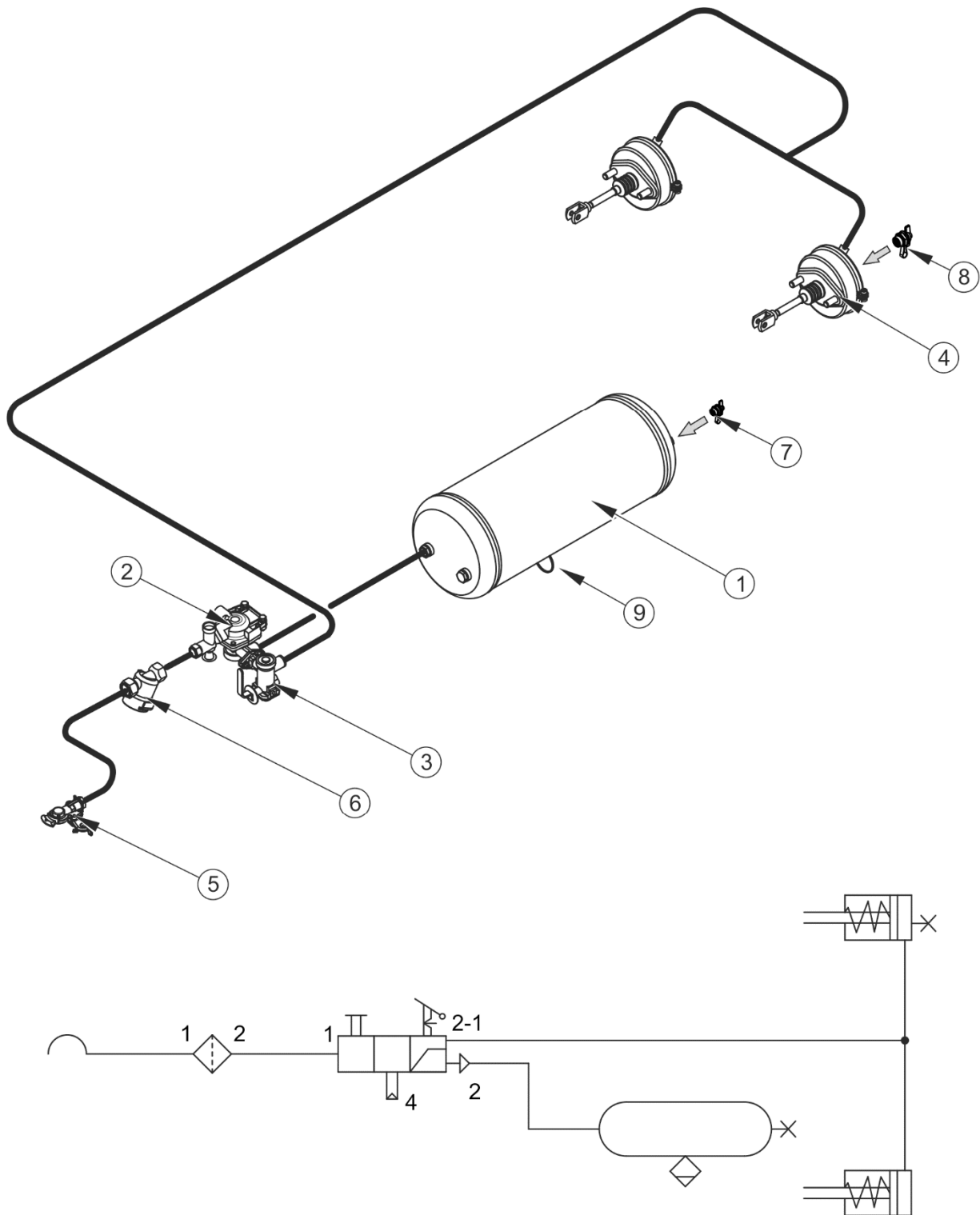

FIGURE 3.9 Single conduit pneumatic system

(1) air tank, (2) control valve, (3) braking force regulator, (4) pneumatic cylinder, (5) conduit connection, (6) air filter, (7) air tank control connector, (8) pneumatic cylinder control connector, (9) drain valve

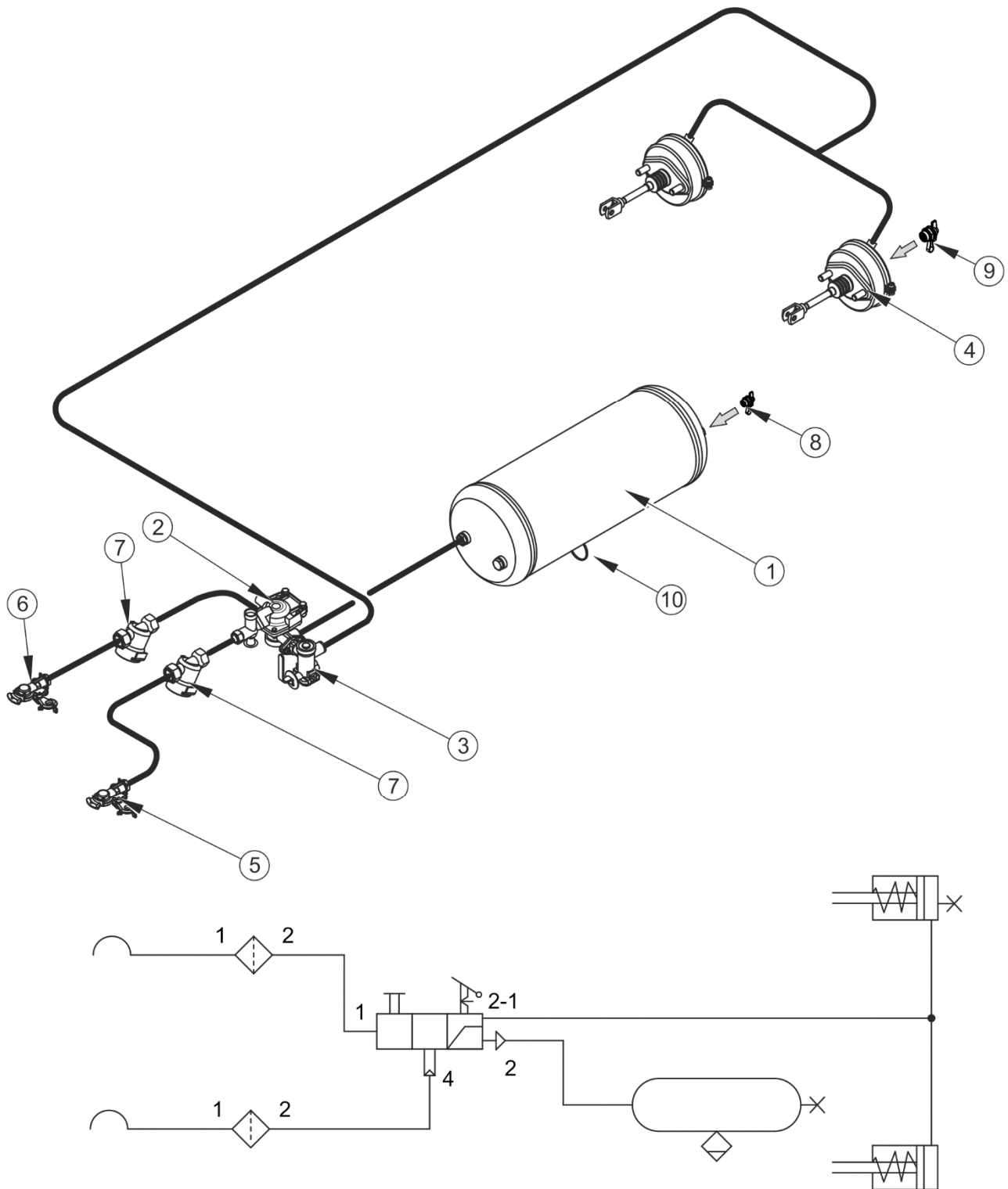

FIGURE 3.10 Double conduit pneumatic system

(1) air tank, (2) control valve, (3) braking force regulator, (4) pneumatic cylinder, (5) conduit connector (red), (6) conduit connector (yellow), (7) air filter, (8) air tank control connector, (9) pneumatic cylinder control connector, (10) drain valve

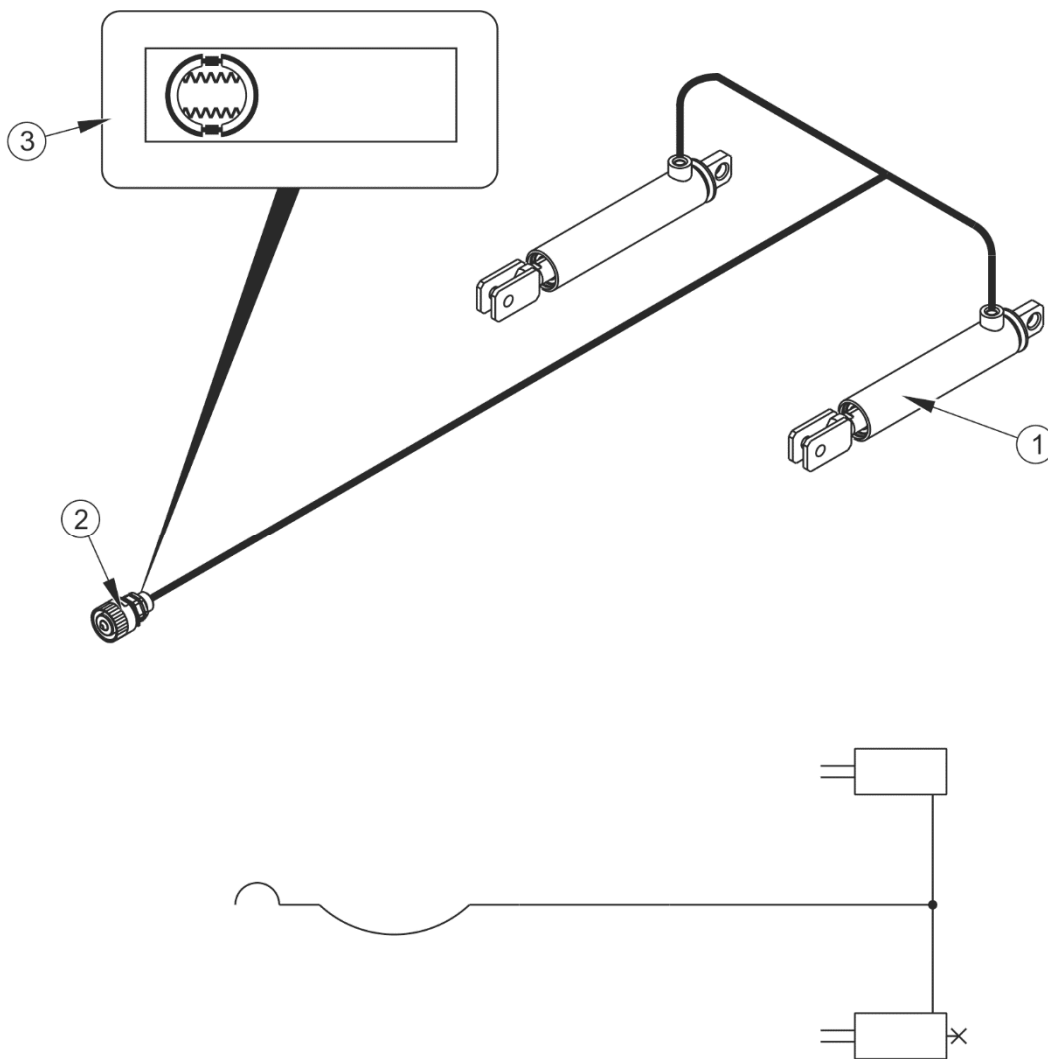

FIGURE 3.11 Design and diagram of hydraulic braking system

(1) hydraulic cylinder, (2) hydraulic quick-coupler, (3) information decal

The main brake is activated from the tractor driver's cab by depressing the brake pedal. The function of the control valve (2) used in the pneumatic systems - figure (3.9), (3.10), is to activate the manure spreader's brakes at the same time when the tractor's brakes are applied. Furthermore, in case of an inadvertent disconnection of the conduit between the manure spreader and the tractor, the control valve will automatically activate machine's brakes. The valve is equipped with the brake applying device to be used when the manure spreader is disconnected from the tractor. When compressed air conduit is connected to the tractor, the device automatically applying the brakes now changes its position to allow normal brake operation.

Three-step brake force regulator - figure (3.12), applied in pneumatic systems adjusts braking force depending on setting. Switching to a suitable working mode is done manually by machine operator using the lever (4) prior to moving off. Three working positions are available: A - "no load", B - "half load" and C - "full load".

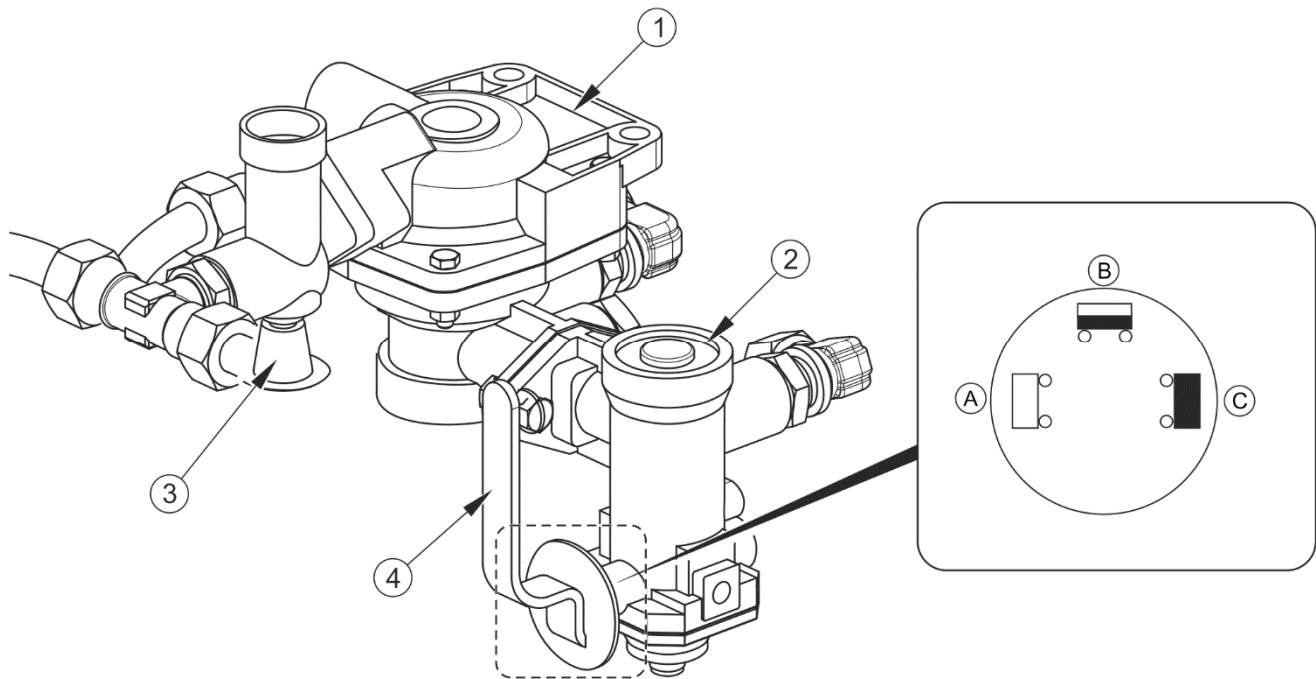

FIGURE 3.12 Control valve and braking force regulator

(1) control valve, (2) brake force regulator, (3) manure spreader parking brake release button, (4) work selection regulator lever, (A) "NO LOAD" position, (B) "HALF LOAD" position, (C) "FULL LOAD" position

3.2.9 PARKING BRAKE

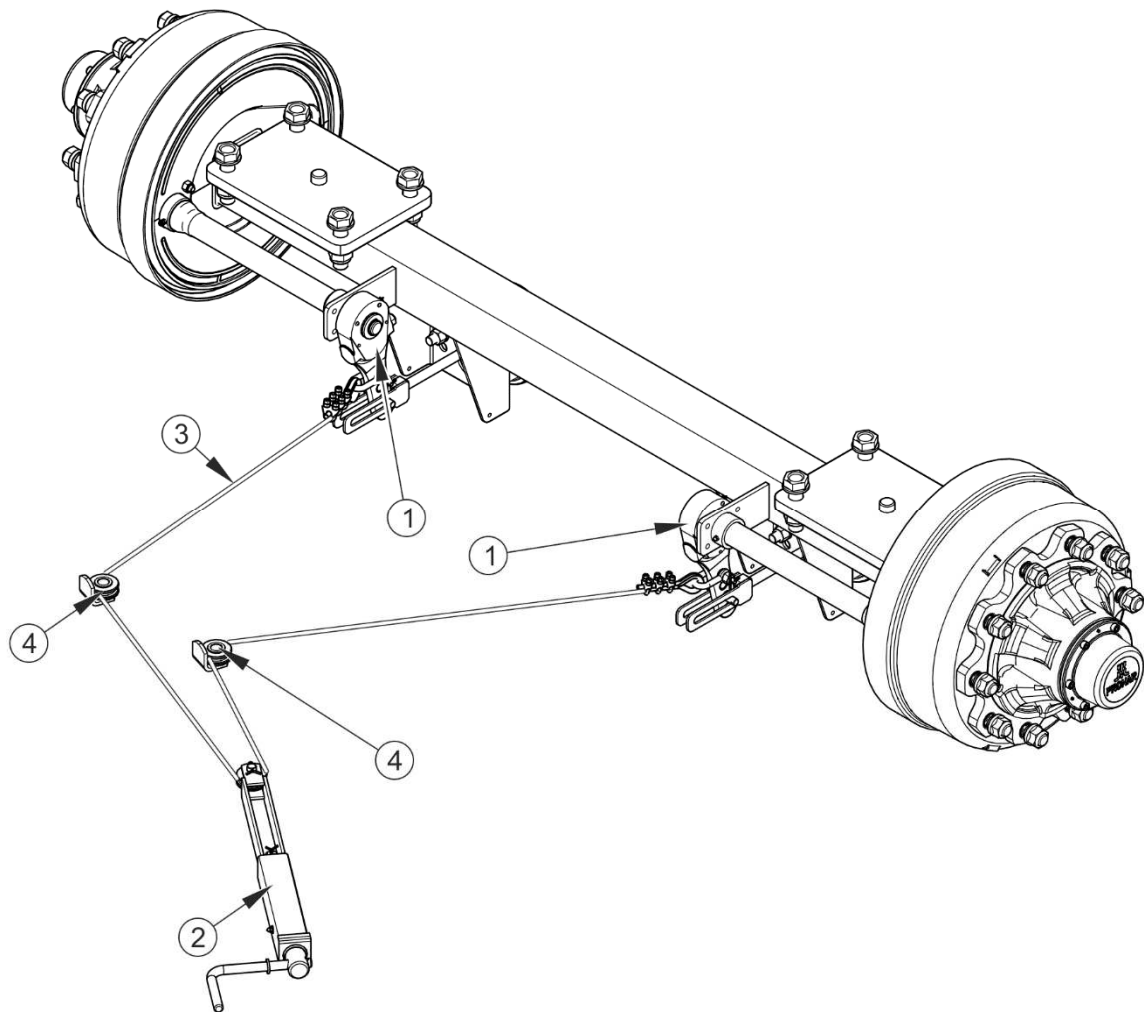

FIGURE 3.13 Parking brake

(1) expander lever, (2) brake crank mechanism, (3) steel cable $L=3\ 200\ \text{mm}$, (4) cable roller

The parking brake is used for immobilising manure spreader while standing motionless. System design is shown in Figure (3.13).

Brake crank mechanism (2) is welded to the left wall of the load box. Expander levers (1) of wheel axle are connected to crank mechanism (2) by means of cable (3) guided in rollers (4). Tightening the cables (turning the brake mechanism crank clockwise) causes tilting of the expander lever, which expands the brake shoes immobilising the manure spreader.

3.2.10 LIGHTING SYSTEM

The manure spreader electrical system is designed for supply of 12 V DC. Connection of the manure spreader electrical system with the tractor should be made through an appropriate connection lead that is part of the machine's standard equipment.

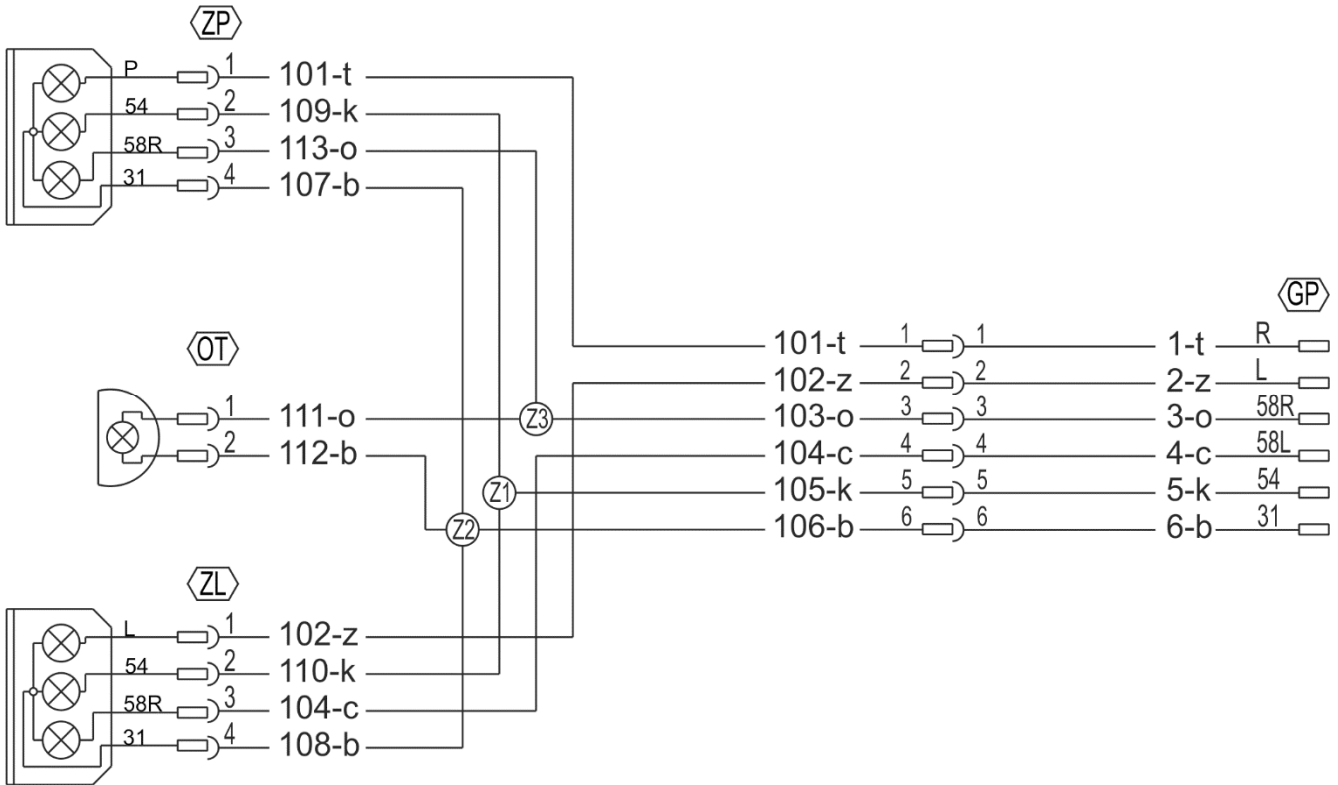

FIGURE 3.14 Electrical system diagram

Marking according to table (3.3), (3.4) and (3.5)

TABLE 3.3 Lead colour marking

MARKING	COLOUR
b	White
c	Black
k	Red
z	Yellow
t	Green
o	brown

TABLE 3.4 List of electrical component markings

SYMBOL	NAME
ZP	Rear right lamp assembly
ZL	Rear left lamp assembly
GP	Seven-pin socket
OT	Licence plate light

TABLE 3.5 GT socket connection markings

MARKING	FUNCTION
31	Ground
L	Left indicator
54	STOP light
58L	Rear left parking light
58R	Rear right parking light
R	Right indicator

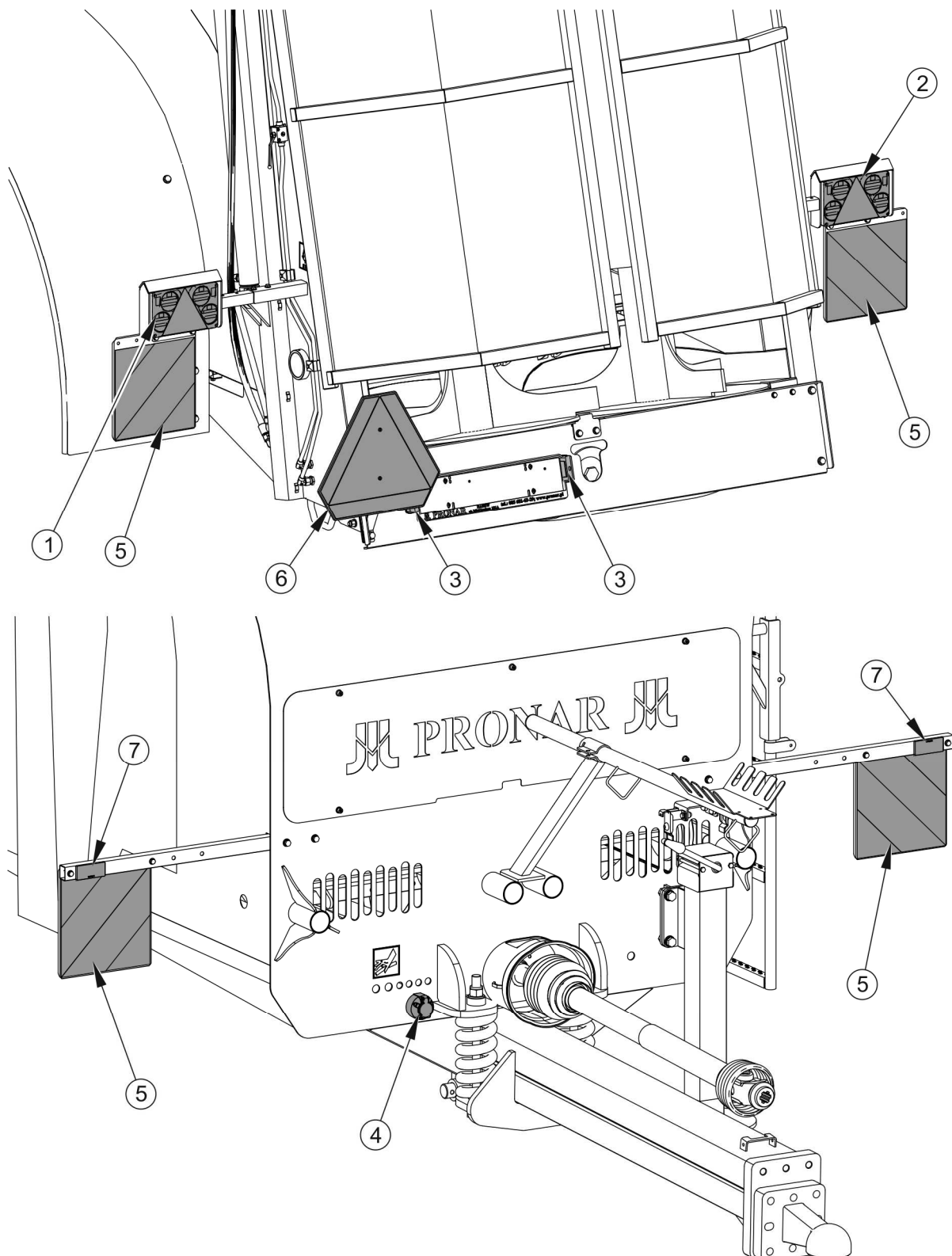

FIGURE 3.15 Arrangement of electrical system components

(1) rear left lamp (2) rear right lamp, (3) licence plate light, (4) connection socket, (5) warning board, (6) attachment point, (7) white reflector

SECTION

4

**CORRECT
USE**

4.1 PREPARING FOR WORK BEFORE FIRST USE

4.1.1 CHECKING THE MANURE SPREADER AFTER DELIVERY

The manure spreader is supplied to the user completely assembled and does not require additional mounting operations of machine sub-assemblies. The manufacturer guarantees that the manure spreader is fully operational and has been checked according to quality control procedures and is ready for use. This does not release the user from an obligation to check the machine's condition prior to purchasing and before first use.

Before connecting the manure spreader, check whether the tractor meets applicable requirements. The manure spreader may be hitched only to such a tractor which meets the requirements specified in table (1.2).

ATTENTION



Before proceeding to hitching to tractor and before first use of the manure spreader the user must carefully read this Operator's Manual and the Operator's Manual of PTO shaft attached to the machine and observe all recommendations.

The manure spreader may only be hitched to a tractor which has the appropriate hitch and required connection sockets for braking, hydraulic and electrical systems. Oil in the tractor external hydraulic system must have appropriate characteristics or must be mixable with the oil in the hydraulic system of the manure spreader.

Before connecting to tractor, machine operator must inspect the technical condition of the manure spreader, adapt it to his/her own needs and prepare it for test start-up. In order to do this:

- ➔ check completeness of machine,
- ➔ check condition of paint coatings, traces of corrosion or mechanical damage (crushing, piercing, bending or breaking of minor elements),
- ➔ check technical condition of protective shields and check if they are correctly installed,
- ➔ visually inspect the manure spreader individual components for mechanical damage resulting from incorrect loading, transport or unloading of the machine,

- ➔ check technical condition of the manure spreader lights and indicators,
- ➔ check technical condition of PTO shafts and their shields as well as completeness of these elements,
- ➔ check technical condition of hydraulic and pneumatic conduits,
- ➔ check that there are no hydraulic oil leaks.

4.1.2 PREPARING THE MANURE SPREADER FOR THE FIRST USE

When preparing the manure spreader for the first use, check the following:

- ➔ all lubrication points; lubricate the machine elements as needed according to recommendations provided in section 5.6 „*MANURE SPREADER LUBRICATION*”,
- ➔ check if the nuts fixing the following components are properly tightened: (wheels, drawbar hitching eye, spreading mechanism),
- ➔ oil level in the spreader unit gear,
- ➔ oil level in the transfer mechanism gear,
- ➔ tension of chain conveyor's chain,
- ➔ technical condition of PTO shaft, its shields and securing chains,
- ➔ make sure that the attached PTO shaft may be connected to the tractor (PTO shaft should be suitable for the tractor – see the Operator's Manual of PTO shaft),
 - ⇒ check length of PTO shaft in the most favourable and difficult working conditions,
 - ⇒ check whether the PTO shaft pipes are sufficiently covered when the widest angle is set,
 - ⇒ check whether the PTO shaft can be still slid when the smallest angle is set (while turning),
- ➔ check correctness of PTO shaft rotation speed (see decal item 12, table (2.1)).

ATTENTION



Pipe profiles of the PTO shaft must overlap at least at 1/2 of the length in normal working conditions and at least at 1/3 of the length in all working conditions.

When adjusting the PTO shaft, follow the instructions presented in the Operator's Manual of the PTO shaft.

When the tractor with the manure spreader are turning or travelling on an uneven terrain, the PTO shaft may be damaged and/or destroyed if it is squeezed or disconnected as a result of its wrong adjustment.



TIP

Adjustment of the PTO shaft applies only to a specific type of tractor. If the machine is connected to a different type of tractor, the adjustment procedure for this type of tractor should be possibly carried out.

4.1.3 TEST START

If all the above checks have been performed and there is no doubt as to the manure spreader's good technical condition, it should be hitched to tractor according to chapter 4.3 „*HITCHING AND DISCONNECTING THE MANURE SPREADER FROM TRACTOR*“. Start tractor engine, check all systems and perform a test run of the manure spreader without load before beginning work. It is recommended that the inspection is conducted by two people, one of which should always remain in the tractor cab. Test start should be conducted according to the sequence shown below.

- ➔ Connect the manure spreader to appropriate hitch on agricultural tractor.
- ➔ Connect PTO shaft and secure it in a proper manner.
- ➔ Raise the support.
- ➔ Connect brake, electrical and hydraulic system conduits.
- ➔ Check correct operation of lights and indicators.
- ➔ Start tractor.
- ➔ When moving off check if the main brakes operate correctly.
- ➔ Check if the chain conveyor operates correctly.

- ⇒ Using the appropriate selective control valve lever in the tractor cab, start the chain conveyor. Set the conveyor speed by turning the knob of the flow regulator installed on the outrigger in the front section of the manure spreader from position „0” to the maximum position „10” and check if the feed direction is correct. Forward or reverse direction of movement is selected using the appropriate selective control valve lever in the tractor cab. Check if conduits are connected in a correct manner and if flow regulator operates correctly.
- ➔ Check correctness of tailgates operation.
 - ⇒ Using the appropriate manifold lever in the tractor cab, open and close the tailgates.
- ➔ Start tractor PTO slowly (starting the drive of the spreader unit wormshafts).
- ➔ Leave for several minutes working at low RPM, during which check:
 - ⇒ that there is no knocking or noise in the drive system and the spreader unit arising from scraping or grinding of metal elements,
 - ⇒ if spreader unit wormshafts rotate smoothly and without resistance.
- ➔ Disengage PTO drive, turn off tractor engine and unhitch the manure spreader from tractor.

**DANGER**

Do NOT use PTO rotation speed other than specified in table 3.1.

The manure spreader may be used only when all preparatory activities have been completed satisfactorily. If during manure spreader test start worrying symptoms occur such as:

- noise and abnormal sounds originating from the abrasion of moving elements of the manure spreader design,
- hydraulic oil leak,
- pressure drop in braking system,
- blocking of brake cylinders,

- other suspected faults

immediately cut off oil supply, disconnect tractor PTO drive and identify a fault. If a fault cannot be rectified or the repair could void the warranty, please contact the retailer or directly the manufacturer for additional clarifications or to perform the repair.

ATTENTION



Check correctness of hydraulic connections. Replace conduit plugs possibly.

Non-adherence to the recommendations stated in the Operator's Manual or improper use of the manure spreader may cause damage to the machine.

The technical condition before starting the manure spreader must be no cause for concern.

4.2 TECHNICAL CONDITION INSPECTION

When preparing the manure spreader for operation check the following daily:

- ➔ technical condition of tyres and tyre pressure,
- ➔ tightening of nuts fixing the following: (wheels, drawbar hitching eye, spreading mechanism),
- ➔ condition of other bolt and nut connections,
- ➔ operation of manure spreader lights and indicators,
- ➔ operation of manure spreader's brake system,
- ➔ correct operation of the hydraulic system,
- ➔ oil level in the spreader unit gear,
- ➔ oil level in the transfer mechanism gear,
- ➔ technical condition of PTO shaft, its shields and securing chains,
- ➔ after a longer storage period of the machine, check technical condition of PTO shaft and grease all the lubrication points according to the Operator's Manual of the PTO shaft,

- ➔ lubricate elements according to guidelines presented in section „*LUBRICATION OF MANURE SPREADER*” in compliance with lubrication schedule,
- ➔ check the floor conveyor tension and adjust if necessary – see section 5.7 „*CHECKING AND ADJUSTMENT OF TENSION OF FLOOR CONVEYOR CHAINS*”.

DANGER



Do NOT use unreliable manure spreader.

The manure spreader must never be used by persons, who are not authorised to drive agricultural tractors, including children and people under the influence of alcohol or other drugs.

Careless and improper use and operation of the manure spreader, and non-compliance with the recommendations given in this operator's manual is dangerous to your health.

Prior to connecting individual system conduits, the user must carefully read the tractor Operator's Manual and observe all Manufacturer's recommendations.

Pneumatic brake systems are equipped with connectors, whose safety caps are made from coloured plastic. The colours of these elements correspond to the colours of the connection sockets in the tractor (yellow, red or black). Hydraulic brake supply conduit plug should be connected to the tractor hydraulic brake socket.

4.3 HITCHING AND DISCONNECTING MANURE SPREADER FROM TRACTOR

Prior to attempting to hitch the manure spreader to tractor, make sure that the tractor is immobilised with parking brake. The manure spreader may be attached only to the tractor equipped with all necessary connections (electric, pneumatic and hydraulic connections) and the tractor hitch in accordance with the requirements of the manure spreader Manufacturer.

ATTENTION



Prior to attaching the manure spreader, check the technical condition of the manure spreader's and tractor's hitch system and connection elements of the hydraulic, electrical and pneumatic systems.

The hydraulic oils in the tractor and the manure spreader must be mixable.

Be especially careful when hitching the machine to tractor.

When hitching is completed, secure the electrical leads and hydraulic and braking system conduits in such a way that they do not become entangled in tractor's moving parts and are not at the risk of breaking or being severed when making turns.

The parking stand must be maximally raised during manure spreader operation or travel.

In order to hitch the manure spreader to the tractor perform the actions below in the sequence presented.

Hitching to tractor

- ➔ Immobilise the manure spreader with parking brake.
- ➔ Position agricultural tractor directly in front of drawbar eye.
- ➔ set the drawbar eye at such a height that it is possible to hitch the machine.
 - ⇒ turn the support crank (1) to raise or lower the drawbar hitching eye – figure (4.1).
- ➔ Reverse tractor, hitch manure spreader, check coupling lock protecting machine against accidental unhitching.
 - ⇒ If the agricultural tractor is equipped with an automatic coupler, ensure that the hitching operation is completed and that drawbar eye is secured.
- ➔ Turn off tractor engine, secure cab to prevent unauthorised access.
- ➔ Raise the support foot maximally upwards using knob.
 - ⇒ After coupling the machines, the support foot must be raised so as not to hit the ground or any other obstacle.

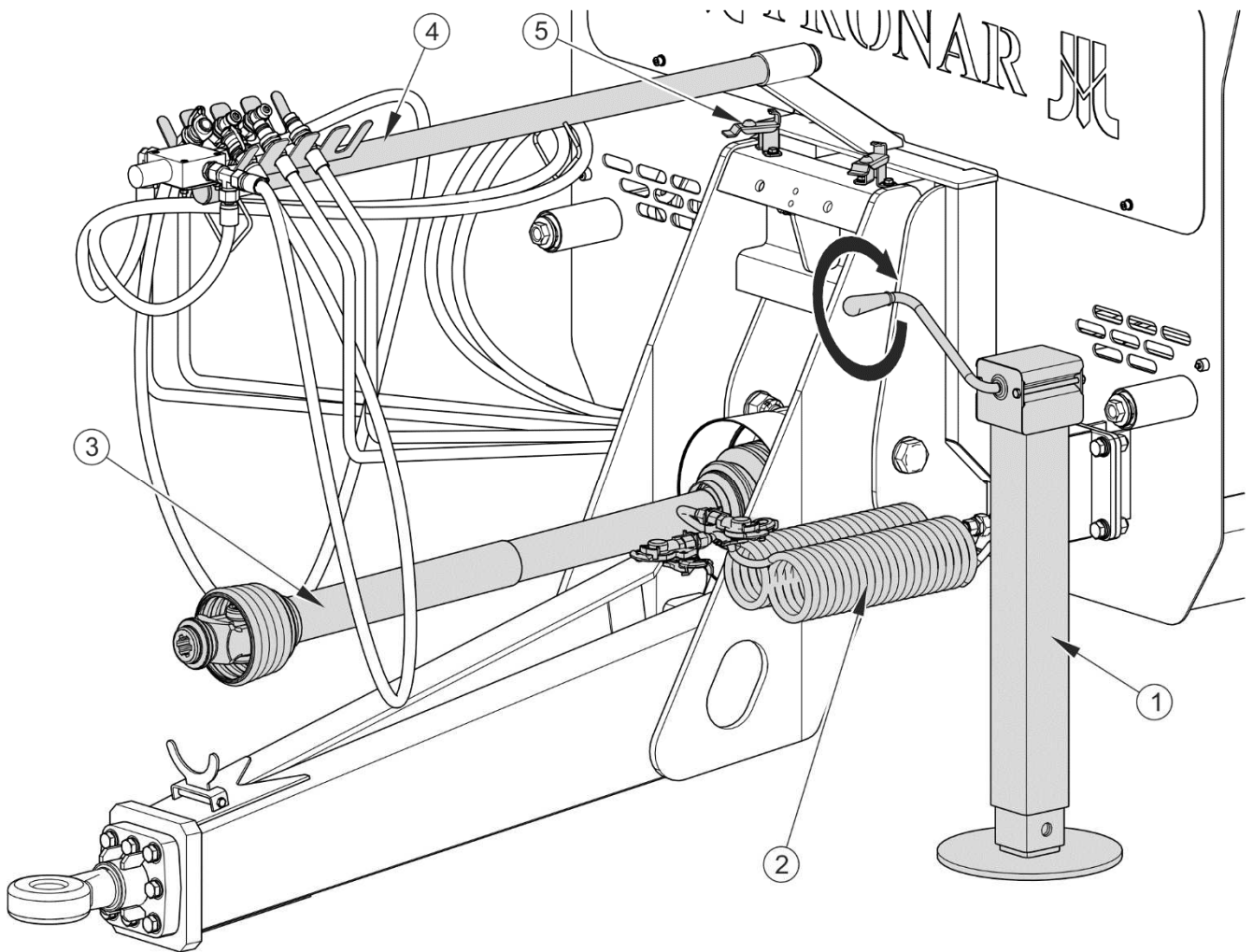



FIGURE 4.1 Hitching to tractor

(1) parking stand, (2) pneumatic conduits, (3) PTO shaft for connecting with tractor, (4) conduit outrigger, (5) connector bracket

- ➔ Connect pneumatic system conduits (2) (applies to double conduit pneumatic system) - figure (4.1).
 - ⇒ Connect pneumatic conduit marked yellow with yellow socket in tractor.
 - ⇒ Connect pneumatic conduit marked red with red socket in tractor.
- ➔ Connect pneumatic system conduit (applies to single conduit pneumatic system).
 - ⇒ Connect pneumatic conduit marked black with black socket in tractor.

- ➔ Connect hydraulic conduits (marked black) of the floor conveyor movement system to the tractor.
 - ⇒ Conveyor connection conduits are marked with decals in the form of arrows indicating the direction of hydraulic oil flow.



ATTENTION

When connecting the control conduits of the conveyor drive motor, be careful not to make wrong connections of conduit pairs. Conduits are identified with information decals.

- ➔ Connect hydraulic conduits of the control system of the tailgate (marked green) and slide gate (marked red) (if they are included in the manure spreader's equipment).
- ➔ Connect main lead supplying electrical lighting system.
- ➔ Install PTO shaft (3) according to guidelines specified in the Operator's Manual of the PTO shaft - figure (4.1).
 - ⇒ Connect the PTO shaft end with the clutch on the machine side.
 - ⇒ Make sure that the shaft ends on the tractor side and the manure spreader side fit well and the linkage is properly secured.
 - ⇒ Attach chains securing the PTO shaft cover.
- ➔ Release parking handbrake by turning the crank of the parking brake's mechanism.



DANGER

When hitching, there must be nobody between the manure spreader and the tractor. When hitching the machine, tractor driver must exercise caution and make sure that nobody is present in the hazard zone.

Make sure that there is nothing and nobody inside the load box.

When connecting the hydraulic conduits to the tractor, make sure that the tractor and manure spreader hydraulic system are not under pressure.

Unhitching the manure spreader

In order to disconnect the manure spreader from the tractor carry out the following actions in the following sequence.

- ➔ Immobilise tractor and manure spreader with parking brake.
- ➔ Place chocks under manure spreader wheel.
 - ⇒ Wheel chocks must be so placed that one is in front of the wheel and the second is behind the wheel - see section 2.
- ➔ Turn off tractor engine. Ensure that unauthorised persons do not have access to the tractor cab.
- ➔ Turning the support crank, set the drawbar eye at such a height that one may safely unhitch the manure spreader.
- ➔ Disconnect from the tractor the hydraulic conduits of the conveyor movement system and the hydraulic conduits of the control system of the tailgate and slide gate (if they are included in the manure spreader's equipment). Protect conduit plugs against contamination by means of caps and place them in the holder on the conduit outrigger (4) – figure (4.1).
- ➔ Disconnect electric lead.
- ➔ Disconnect pneumatic system conduits and place them in holders (5) – figure (4.1) (applies to double conduit pneumatic system).
 - ⇒ Disconnect pneumatic conduit marked red.
 - ⇒ Disconnect pneumatic conduit marked yellow.
- ➔ Disconnect pneumatic system conduits and place them in holder (5) (applies to single conduit pneumatic system).
 - ⇒ Disconnect pneumatic conduit marked black.
- ➔ Disconnect PTO shaft.
- ➔ Release tractor hitch and disconnect manure spreader drawbar from tractor hitch and drive tractor away.
- ➔ Secure PTO shaft.

ATTENTION



Exercise caution when disconnecting the manure spreader from the tractor. Ensure good visibility. Unless it is necessary, do not go between tractor and manure spreader.

The manure spreader disconnected from the tractor must be immobilised with the parking brake. If the manure spreader is positioned on a slope or elevation it shall be additionally secured against moving by placing chocks or other objects without sharp edges under the manure spreader's wheels.

Before disconnecting conduits, drawbar eye and PTO shaft, close tractor cab and secure it against access by unauthorised persons. Turn off tractor engine.

Do NOT park a loaded manure spreader, which is disconnected from the tractor and resting on the parking stand.

4.4 LOADING THE LOAD BOX

Before loading, position the manure spreader connected properly with the tractor on level and stable surface. Immobilise both machines with parking brake.

When loading the manure spreader, it is recommended to use an appropriate loader or conveyor. If loading is carried out by a loader with bucket forks, the width of bucket forks should not exceed the load box length. Bucket forks should be emptied by tilting when positioned not higher than 1 meter above the load box. Do not compact manure. When loading, pay attention not to overload the manure spreader. Height of loaded manure must not exceed the height of the spreader unit mechanism.

In order to ensure optimum spreading, efforts should be made to evenly distribute the load in the load box. Manure should be loaded starting from the rear and moving towards the front of the manure spreader. Such loading method has positive impact on quality of manure spreading.

Due to the various density of fertilizing materials, using the total load box capacity may cause exceeding permissible carrying capacity of the manure spreader. Guideline specific weight of selected materials is shown in table (4.1). Take care not to overload the manure spreader.

TABLE 4.1 Guideline weights by volume of selected loads

TYPE OF MATERIAL	WEIGHT BY VOLUME KG / M ³
Organic fertilisers:	
Old manure	700 - 800
Mature manure	800 - 900
Fresh manure	700 - 750
Compost	950 – 1 100

Regardless of the type of load carried, the user is obliged to secure it in such a manner that the load is unable to spread and cause contamination of the road. If this is impossible, do NOT transport this type of load.

ATTENTION



Do NOT exceed permissible load weight of manure spreader because this may cause danger to road traffic and cause damage to the machine.

Unevenly loaded manure is spread unevenly in the field.

Height of loaded manure must not exceed the height of the spreader unit mechanism.

When loading the manure spreader, pay attention not to load manure onto the spreader unit blades to ensure unloaded start of the adapter.

4.5 SPREADING AND ADJUSTING FERTILIZER DOSE

4.5.1 ADJUSTING FERTILIZER DOSE

Amount of material spread on a specific field area depends on the following factors:

- load height,
- working width - depends on kind of material spread,
- chain conveyor speed,
- travel speed.

Based on practical experience, set a suitable speed of chain conveyor using knob (3) on flow regulator (1) located on valve bracket (2) in the front section of the manure spreader - Figure (4.2).

- Conveyor speed is reduced by turning the regulator knob towards "0" setting.
- Conveyor speed is increased by turning the regulator knob towards „10" setting.

**TIP**

When the manure spreader travel speed is high and the conveyor speed is low, a small spreading dose is obtained.

When the manure spreader travel speed is low and the conveyor speed is high, a large spreading dose is obtained.

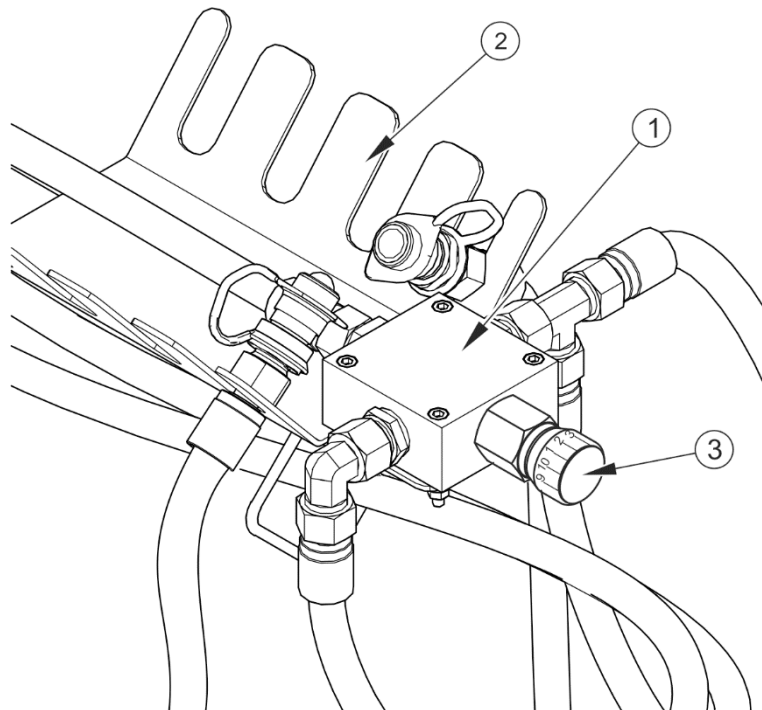

FIGURE 4.2 Adjusting conveyor speed

(1) flow regulator, (2) valve bracket, (3) adjusting knob with scale from 0 to 10

4.5.2 SPREADING MANURE IN THE FIELD

Before commencing work, check again the technical condition of hydraulic connections and safety guards installed on the manure spreader and PTO shaft.

To ensure precise manure spreading also along the field boundaries, the rear shields of the manure spreader can be set in such a manner as to reduce the spreading width on one or both sides of the manure spreader.

DANGER



Operation of the manure spreader without safety guards or with damaged PTO shaft creates a direct threat to health and life of the machine operators.

Keep a safe distance from electric power lines. Do NOT spread manure near grazing animals.

Do NOT use PTO rotation speed other than specified in table 3.1. If PTO shaft works at a different speed, rotation speed of spreading wormshafts and discs will be too low or too high and the drive will be at the risk of damage.

Take special care not to close or open the tailgates when they are locked by means of two cut-off valves. Otherwise, hydraulic cylinders and/or tailgates may be damaged.

The manure spreader starting procedure in order to spread manure in the field.

- ➔ Using the appropriate manifold lever in the tractor cab, open the tailgates (if they are included in the manure spreader's equipment).
 - ⇒ If hydraulic valve of one of the tailgates is closed, only one tailgate will open.
 - ⇒ To limit spreading to one side, open both tailgates maximally. Next, using the hydraulic valve, close the tailgate which will not be controlled and change the position of the other tailgate from the tractor.
- ➔ Set the tractor PTO rotation speed proper for the manure spreader (specified in table 3.1.).
- ➔ Start the spreader unit by engaging PTO drive in tractor.
 - ⇒ Start tractor PTO slowly in order to avoid damage to PTO shaft.
- ➔ Raise the load box slide gate (if included in the manure spreader's equipment).
- ➔ Engage the chain conveyor.
- ➔ Engage appropriate tractor gear and start working.
 - ⇒ Disengage PTO when making turns during operation. Protection of PTO shaft and uniform spreading are ensured in this way.

TIP



In order to obtain uniform spreading in the beginning of operation, increase PTO rotation maximally to the recommended speed and engage the chain conveyor when the manure spreader is still motionless. Spread manure while the manure spreader is motionless until a sufficient amount of manure is delivered to the spreader unit wormshafts. Then, engage appropriate tractor gear and start working.

In order to ensure optimum spreading, maintain PTO rotation speed approximately at the level specified in table 3.1.

ATTENTION



Do NOT use another manure spreader starting procedure. The use of another manure spreader starting procedure may cause damage to the manure spreader and pose a threat to health and life of the machine operators.

Load may be moved forwards only in exceptional cases, for example, if spreader unit wormshafts are blocked or in case of slipping of rear tractor wheels. When moving the load forwards, the load must not touch the front wall because the load box or drive transmission system may be damaged.

Before turning and during transport the tractor PTO drive should be disengaged.

4.6 SPREADING MECHANISM CLOGGING

If the spreading mechanism (spreader unit) is clogged during spreading, the clogging elements can be removed by moving the floor conveyor towards the front wall. If the spreader unit is still clogged, disengage tractor PTO drive and chain conveyor. Turn off tractor engine and disconnect PTO shaft. Next, remove the elements clogging the spreader unit using the appropriate tool. Remove strings from manure, if they occur. Otherwise, strings can deteriorate quality of manure spreading. Entwined strings should be removed using a sharp tool.

ATTENTION



When the load box is loaded, direction of the feeding mechanism movement may be reversed only for a short time.

During work, use proper, close-fitting protective clothing, gloves and appropriate tools.

Servicing and repair work should be carried out in line with the general principles of workplace health and safety. In the event of injury, the wound must be immediately cleaned and disinfected. In the event of more serious injuries, seek a doctor's advice.

4.7 PROPER USE AND MAINTENANCE OF TYRES

- When working with tyres, the manure spreader should be secured against rolling by placing chocks under the wheels. Wheels can be taken off only when the manure spreader is not loaded.
- Repair work on the wheels or tyres should be carried out by persons trained and entitled to do so. This work should be carried out using appropriate tools.
- Each time a wheel is fitted, tighten all nuts after the first 10 working hours and then check proper tightening of nuts every 50 working hours. The above actions should be repeated each time a wheel has been removed from the wheel axle.
- Regularly check and maintain correct pressure in tyres according to Operator's Manual (especially if manure spreader is not used for a longer period).
- Pressure and tyres should be also checked during the whole day of intensive work. Please note that higher temperatures could raise tyre pressure by as much as 1 bar. At high temperatures and pressure, reduce load or speed.
- Do not release air from warm tyres to adjust the pressure or the tyres will be underinflated when temperatures return to normal.
- Tyre valves should be protected with the appropriate caps to avoid soiling.
- Do not exceed the manure spreader's maximum design speed.
- When machine is operated all day, check temperature of tyres.
- Adhere to 30 minutes rest for cooling tyres after driving 75 km or after 150 minutes continuous travel depending on which occurs first.
- Avoid potholes, sudden manoeuvres or high speeds when turning.

SECTION

5

MAINTENANCE

5.1 PRELIMINARY INFORMATION

When using the manure spreader, regular inspections of its technical condition are essential and the performance of maintenance procedures, which keep the machine in good technical condition. In connection with this the user of the manure spreader is obliged to perform all the maintenance and adjustment procedures defined by the Manufacturer.

Repairs during the warranty period may only be performed by authorised service points.

Detailed procedures and extent of activities which the user may perform by himself are described in this section. In the event of unauthorised repairs, changes to factory settings and other actions, which are not regarded as possible for the manure spreader operator to perform, the user shall invalidate the warranty.

5.2 MAINTENANCE OF BRAKES AND AXLES

5.2.1 PRELIMINARY INFORMATION

Work connected with the repair, change or regeneration of axle and brakes elements should be entrusted to specialist establishments, having the appropriate technology and qualifications for this type of work.

The responsibilities of the user are limited to:

- initial inspection of axle brakes,
- checking brake shoe linings for wear,
- inspection and adjustment of slackness of axle bearings,
- mounting and dismounting wheel, inspection of wheel tightening,
- checking air pressure, evaluating technical condition of wheels and tyres,
- mechanical brakes adjustment,
- replacing the parking brake cable and tension adjustment

Procedures connected with:

- changing grease in axle bearings,
- changing bearings, hub seals,

- changing brake linings, repairing brake,

may be performed by specialist workshops.



DANGER

Do NOT use the manure spreader when braking system is unreliable.

5.2.2 INITIAL INSPECTION OF AXLE BRAKES

After purchasing manure spreader, the user is responsible for general checking of brake system of manure spreader axle.

Inspection procedures

- ➔ Hitch manure spreader to tractor and place chocks under manure spreader wheel.
- ➔ Check fixing of cylinder and return springs.
- ➔ Engage and release in turn the main brake and then the manure spreader parking brake.
 - ⇒ Main brake and parking brake should be engaged and released without great resistance and jamming.
- ➔ Check cylinder movement and correct return of piston to start position.
 - ⇒ The help of a second person is required, who shall engage manure spreader brake.
- ➔ Check if axle elements are in place, (cotter pins in castellated nuts, expansion rings etc.).
- ➔ Check pneumatic cylinders for tightness – see section 5.3.2.



Initial inspection of axle brakes must be conducted:

- after the first use of the manure spreader,
- after first travel with load.

5.2.3 CHECKING BRAKE SHOE LININGS FOR WEAR

Manure spreader brake shoes should be replaced when the brake lining thickness is less than the minimum specified by the manufacturer.



TIP

Minimum thickness of brake shoe linings is 5 mm.

Check brake shoe linings for wear through the inspection opening (2) – see Figure (5.1).



Check brake shoe linings for wear:

- every 3 months,
- if brakes overheat,
- if brake cylinder piston stroke is significantly longer,
- if there are unusual noises from the drum of wheel axle.

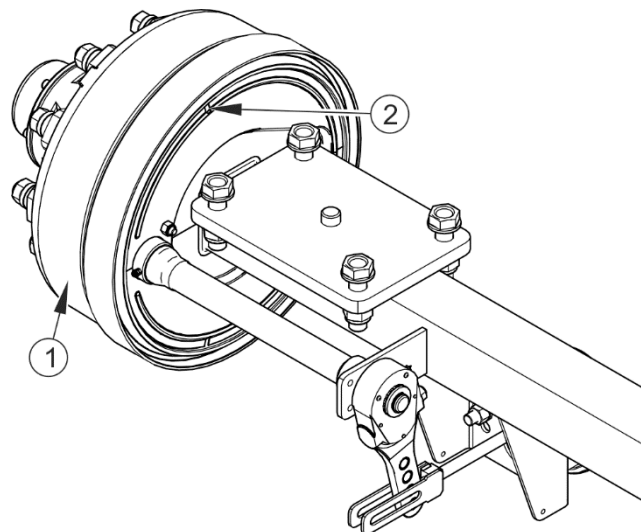

FIGURE 5.1 Checking brake shoe linings

(1) wheel axle drum, (2) brake shoe linings for wear inspection opening

5.2.4 CHECKING WHEEL AXLE BEARINGS FOR SLACKNESS

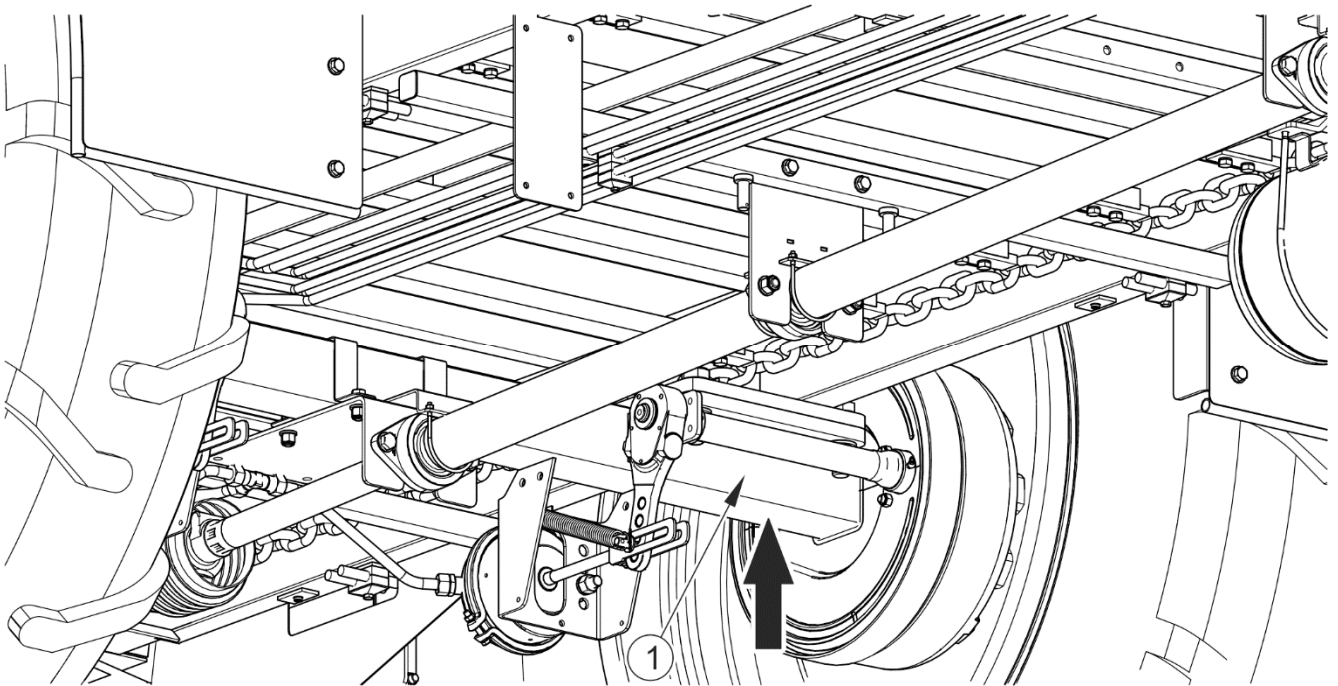

FIGURE 5.2 Lifting jack support point

(1) wheel axle

Preparation procedures

- ➔ Hitch manure spreader to tractor, immobilise tractor with parking brake.
- ➔ Park tractor and manure spreader on hard level ground.
 - ⇒ Tractor must be placed to drive forward.
- ➔ Place the wheel chocks under the manure spreader's wheel opposite to the lifted wheel. Ensure that manure spreader shall not move during inspection.
- ➔ Raise the wheel (opposite to the side where chocks are placed).
 - ⇒ Lifting jack should be placed as close as possible to the place where wheel axle (1) is attached to the manure spreader frame – figure (5.2). Recommended support point is marked with an arrow. Lifting jack must be suited to weight of manure spreader.

Checking wheel axle bearings for slackness

- ➔ Turning the wheel slowly in both directions check that movement is smooth and that the wheel rotates without excessive resistance.
- ➔ Turn the wheel so that it rotates very quickly, check that the bearing does not make any unusual sounds.
- ➔ Moving the wheel try to detect slackness.
 - ⇒ You may use a lever placed under the wheel supporting the other end on the floor.
- ➔ Repeat the procedure for each wheel individually, remembering that the jack must be on the side opposite to the chocks.



Checking wheel axle bearings for slackness:

- after travelling the first 500 km,
- after travelling next 1 500 – 2 000 km,
- before intensive use of manure spreader,

If slackness is felt, adjust bearings. Unusual sounds coming from bearing may be the symptoms of excessive wear, dirt or damage. In such an event the bearing, together with sealing ring, should be replaced with new parts, or cleaned and greased again. During inspection of bearings ensure that possibly detected slackness comes from the bearing and not from the suspension system.



TIP

If hub cover is damaged or missing, contamination and dampness enter the hub, which causes significantly faster wear of bearing and hub seals.

Bearing life is dependent on working conditions of manure spreader, loading, speed of travel and lubrication conditions.

Check condition of hub cover, if necessary replace it with a new cover. Inspection of bearing slackness may only be conducted when the manure spreader is hitched to a tractor and the load box is empty.

**DANGER**

Before commencing work, the user must read the user manual for lifting jack and adhere to the manufacturer's instructions.

The lifting jack must be stably supported on the ground and so must the axle.

Ensure that manure spreader shall not move during inspection of axle bearing slackness.

5.2.5 ADJUSTMENT OF SLACKNESS OF WHEEL AXLE BEARINGS**Preparation procedures**

- ➔ Prepare tractor and manure spreader for adjustment procedures according to description provided in section 5.2.4.

Adjustment of slackness of axle bearings

- ➔ Take off hub cover (1) – figure (5.3).
- ➔ Take out split cotter pin (3) securing castellated nut (2).
- ➔ Tighten castellated nut in order to eliminate slackness.
 - ⇒ Wheel should rotate with insignificant resistance.
- ➔ Undo nut (not less than 1/3 rotation) to align the nearest thread groove with the opening in wheel axle pin. Wheel should rotate without excessive resistance.
 - ⇒ Nut must not be excessively tightened. Do not apply excessive pressure because working conditions of the bearings may deteriorate.
- ➔ Secure castellated nut with cotter pin and mount hub cap.
- ➔ Delicately tap hub cap with rubber or wooden hammer.

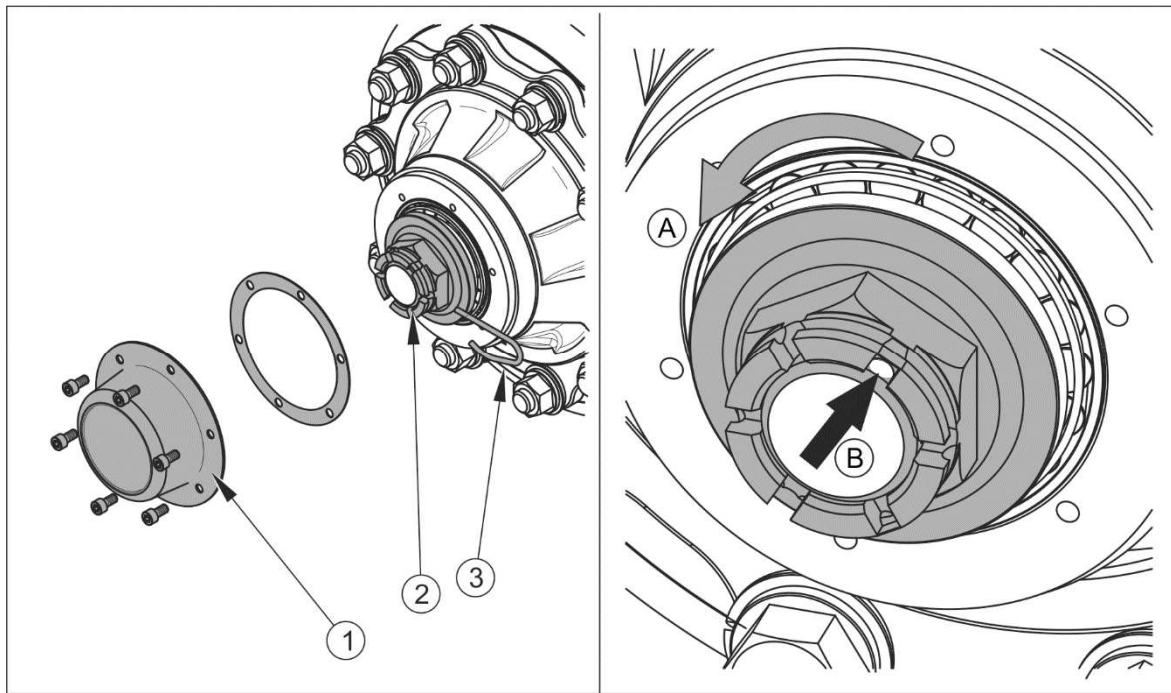

FIGURE 5.3 Adjustment of axle bearings

(1) hub cover, (2) castellated nut, (3) cotter pin

The wheel should turn smoothly without stiffness or detectable resistance not originating from abrasion of brake shoes in brake drum. Adjustment of bearing slackness may only be conducted when the manure spreader is hitched to a tractor and the load box is empty.



TIP

If the wheel is dismantled, bearing slackness is easy to check and adjust.

5.2.6 MOUNTING AND DISMOUNTING WHEEL, INSPECTION OF WHEEL NUT TIGHTENING

Dismounting wheel

- ➔ Immobilise the manure spreader with parking brake.
- ➔ Place the wheel chocks under the wheel opposite to the dismantled wheel.
- ➔ Ensure that the manure spreader is properly secured and shall not move during wheel dismantling.

- ➔ Loosen wheel nuts according to sequence given in figure (5.4).
- ➔ Place a lifting jack and raise the manure spreader to a sufficient height so that the wheel to be replaced does not touch the ground.
- ➔ Dismount wheel.

Wheel mounting

- ➔ Clean axle pins and nuts of contamination.
 - ⇒ Do not grease thread of nuts and pins.
- ➔ Check condition of pins and nuts, if necessary replace them.
- ➔ Place wheel on hub, tighten nuts so that wheel rim adjoins hub exactly.
- ➔ Lower the manure spreader, tighten nuts according to recommended torque and given sequence.



TIP

Wheel nuts should be tightened using a torque of 450Nm - nuts M22x1.5.

Tightening nuts

Nuts should be tightened gradually diagonally, (in several stages, until obtaining the required tightening torque) using a torque spanner.



ATTENTION

Wheel nuts must not be tightened with impact wrench, because of danger of exceeding permissible tightening torque, the consequence of which may be breaking the thread connection or breaking off the hub pin.

The greatest precision is achieved using a torque spanner. Before commencing work, ensure that correct tightening torque value is set.



Check tightening of axle wheel nuts:

- each time a wheel is fitted, after the first 10 working hours,
- every 50 working hours during operation.

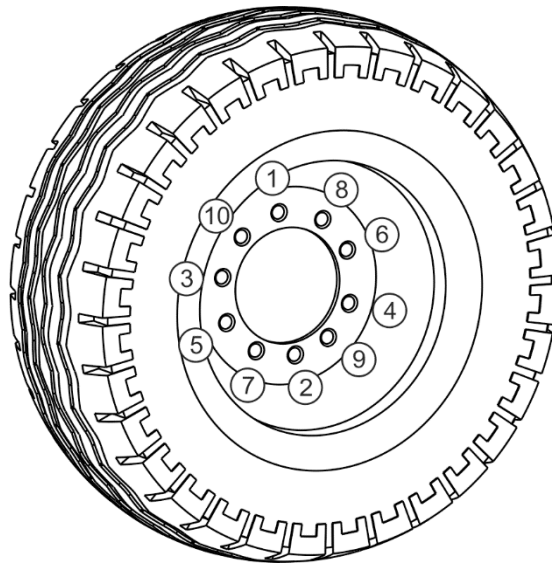

FIGURE 5.4 Sequence of tightening nuts, axles with 10 M22x1.5 pins

(1) - (10) sequence of nut tightening

5.2.7 CHECKING AIR PRESSURE IN TYRES, EVALUATING TECHNICAL CONDITION OF TYRES AND STEEL WHEELS

Air pressure in tyres should be checked each time after changing a spare wheel and at least once a month. In the event of intensive use, air pressure in tyres should be checked more frequently. The manure spreader must be unloaded during checking. Checking should be done before travelling when tyres are not heated, or after an extended period of parking.



TIP

Tyre pressure values are specified in information decal, placed on wheel or on upper frame above manure spreader wheel.

While checking pressure pay attention to technical condition of wheels and tyres. Look carefully at tyre sides and check the condition of tread.

In case of mechanical damage consult the nearest tyre service and check whether the tyre defect requires tyre replacement.



DANGER

Damaged tyres or wheels may be the cause of a serious accident.

Wheels should be inspected with regard to distortion, breaking of material, breaking of welds, corrosion, especially in the area of welds and contact with tyre.

Proper technical condition and appropriate maintenance of wheels significantly extend the life of these components and ensure appropriate level of safety for manure spreader users.



Checking air pressure in tyres and visual inspection of steel wheels:

- every 1 month of use,
- if needed.

5.2.8 MECHANICAL BRAKES ADJUSTMENT

Considerable wear of brake shoe linings results in increased brake cylinder piston stroke and worse braking efficiency.



TIP

Correct brake cylinder piston stroke should be within the range of 25 – 45 mm.

During braking, the brake cylinder piston stroke should be within the specified operating range. Braking force decreases when the operating angle of the brake cylinder piston (5) in relation to the expander arm (1) is wrong – figure (5.5). In order to obtain the optimum mechanical operating angle, the cylinder piston fork (5) must be installed on the expander arm (3) in such a manner as to ensure that the operating angle at full braking is about 90°- figure (5.6).



ATTENTION

Incorrectly adjusted brake may cause rubbing of brake shoes against brake drums, which may lead to faster wear of brake linings and/or brake overheating.

TABLE 5.1 Operating data of pneumatic cylinder

NOMINAL CYLINDER STROKE L [MM]	MINIMUM CYLINDER STROKE L _{MIN} [MM]	MAXIMUM CYLINDER STROKE L _{MAX} [MM]
75	25	45



Check technical condition of brakes:

- Before the period of intensive use.
- Every 6 months.
- After repair of braking system.
- In case of uneven wheel braking.

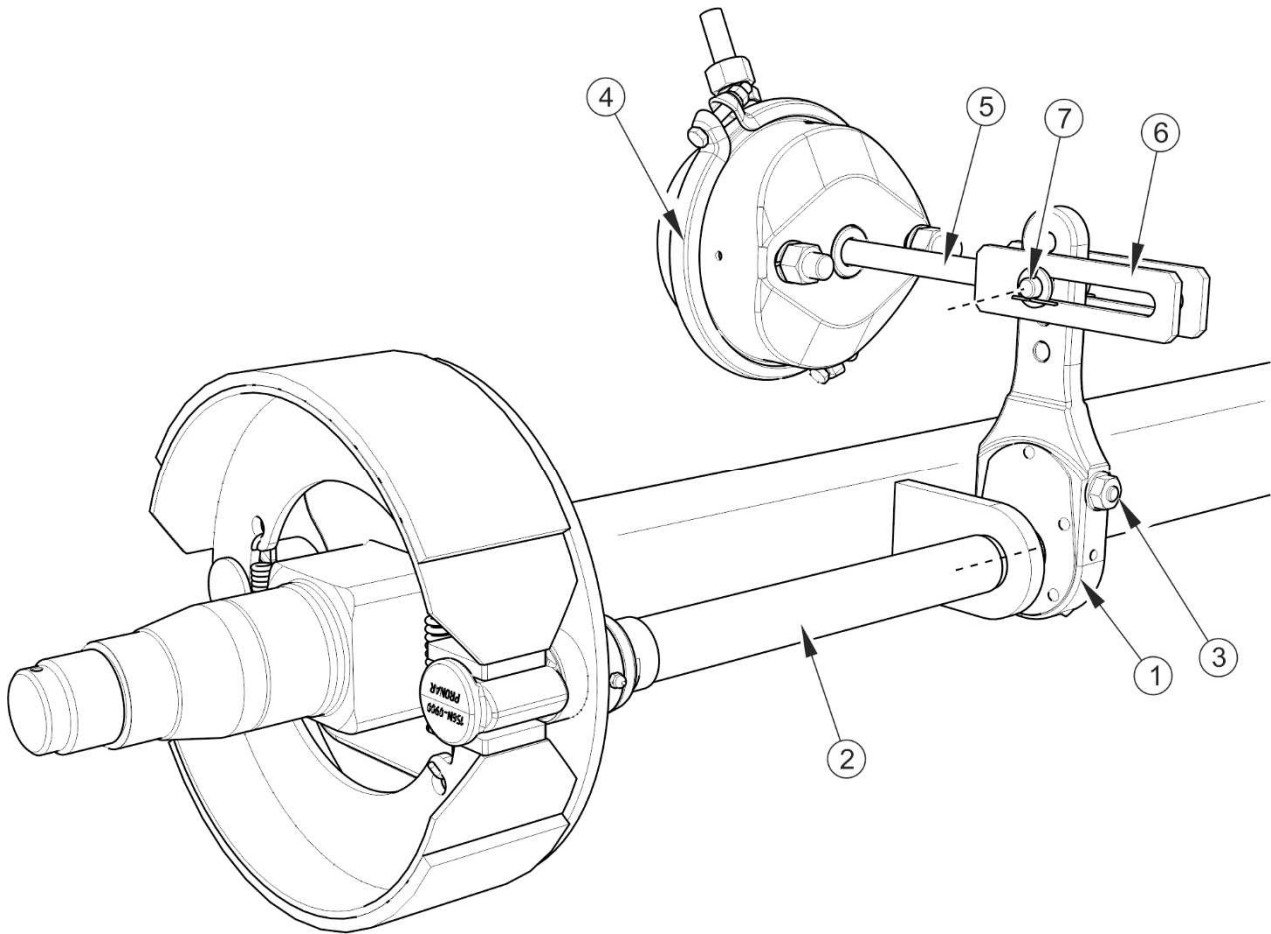



FIGURE 5.5 Design of wheel axle brake

(1) expander arm , (2) expander shaft, (3) adjustment bolt, (4) brake cylinder, (5) brake cylinder piston, (6) cylinder fork, (7) fork pin



ATTENTION

The positions for fixing the brake cylinder in the bracket openings and the brake cylinder pin in the expander arm are determined by the Manufacturer and must not be changed.

Each time when dismantling the pin or brake cylinder, the original fixing position should be marked.

The inspection of the brake operation involves measuring the extension length of each brake cylinder piston while braking at parking. If the brake cylinder piston stroke exceeds the maximum value (45 mm), the braking system should be adjusted.

Required maintenance activities:

- ➔ Hitch the manure spreader to tractor.
- ➔ Turn off tractor engine and remove key from ignition.
- ➔ Immobilise tractor with parking brake.
- ➔ Make sure that the manure spreader's brakes are not engaged.
- ➔ Secure the manure spreader with wheel chocks.
- ➔ Make a line (A) on the brake cylinder piston (1) to indicate the position of the maximum withdrawal of the brake cylinder piston when the manure spreader's brakes are released – figure (5.6).
- ➔ Press the tractor brake pedal and mark the position of the maximum extension of the brake cylinder piston with a line (B).
- ➔ Measure the distance between lines (A) and (B). If the brake cylinder piston stroke is outside the proper operating range, adjust the expander arm.
- ➔ Dismantle brake cylinder fork pin.
- ➔ Remember or mark the original position of pin (6) of brake cylinder fork (5) in expander arm opening (3) – figure (5.6).
- ➔ Check if the brake cylinder piston moves freely and within the whole nominal range.

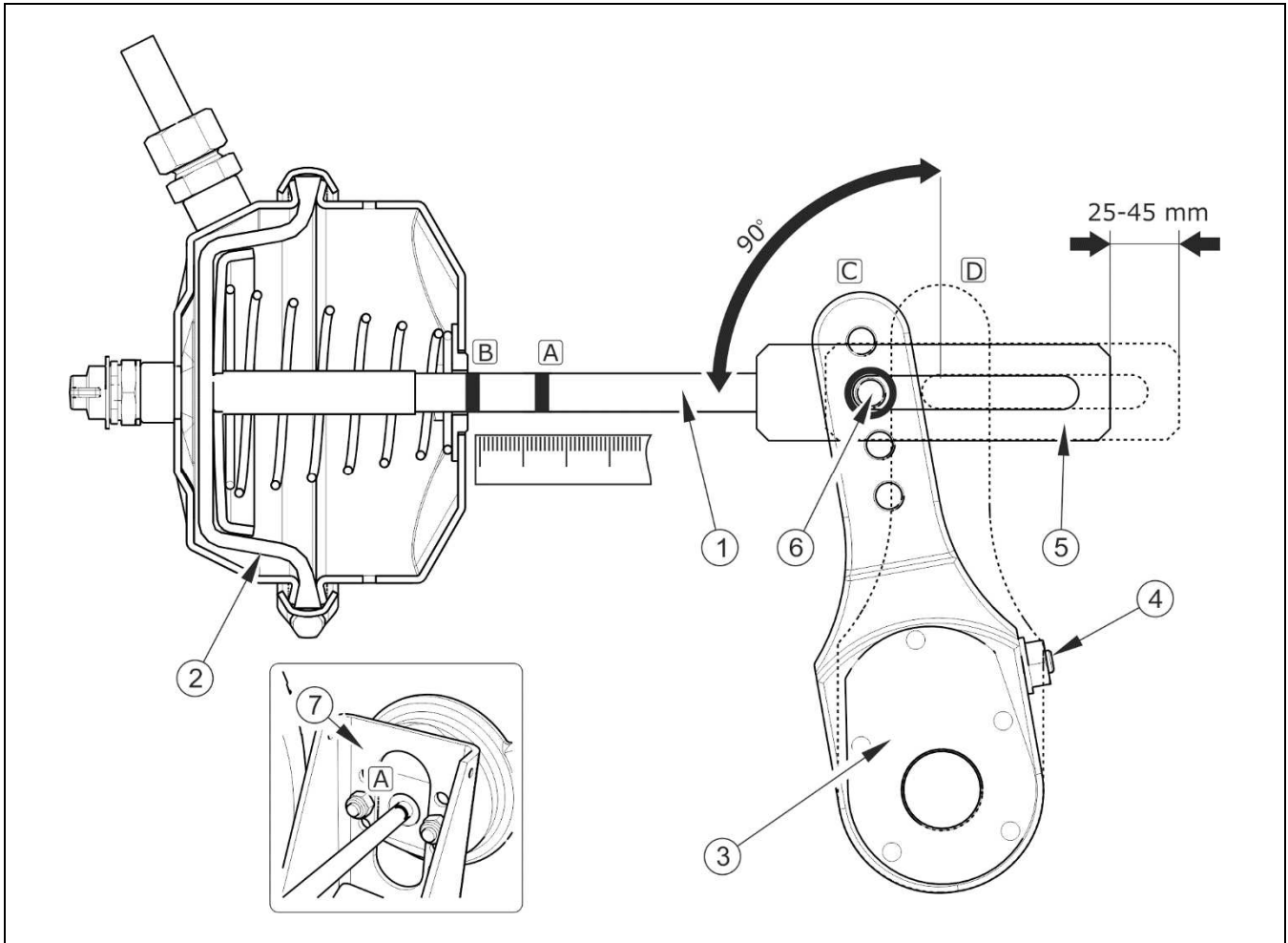

FIGURE 5.6 Principle of brake system adjustment

(1) brake cylinder piston, (2) brake cylinder membrane, (3) expander arm, (4) adjustment bolt, (5) cylinder fork, (6) position of fork pin, (7) brake cylinder bracket, (A) mark on the brake cylinder at brake release position, (B) mark on the brake cylinder at full braking position, (C) position of arm at brake release position, (D) position of arm at full braking position

- ➔ Check if the brake cylinder vent holes are not blocked with impurities and that there is no water or ice inside the brake cylinder. Check if the brake cylinder is correctly installed.
- ➔ Clean the brake cylinder. If necessary, defrost the brake cylinder and drain water through the unblocked vent holes. Replace damaged brake cylinder with a new one. When installing the brake cylinder, maintain its original position with regard to bracket (7).
- ➔ Rotate adjustment bolt (4) to align the marked expander arm opening with the brake cylinder fork opening.

- ⇒ During adjustment, membrane (2) must rest on the rear wall of the brake cylinder – compare figure (5.6).
- ➔ Install the brake cylinder fork pin and washers and secure the pin with cotter pins.
 - ➔ Rotate adjustment bolt (4) to the right until one or two clicking sounds are heard in the expander arm regulating mechanism.
 - ➔ Repeat adjustment activities for the other brake cylinder on the same axle.
 - ➔ Engage the brake.
 - ➔ Remove previous marks and measure the brake cylinder piston stroke again.
 - ➔ If the brake cylinder piston stroke is outside the proper operating range, repeat the adjustment.

5.2.9 CHANGE OF PARKING BRAKE CABLE AND ADJUSTMENT OF CABLE TENSION.



Checking and/or adjustment of parking brake:

- every 12 months,
- if needed.

Proper operation of the parking brake is dependent on the effectiveness of the axle brake and the correct brake cables tension.

Adjustment of parking brake cable tension should be conducted in the event of:

- stretching of cable,
- loosening of parking brake cable clamps
- after adjustment of axle brakes,
- after repairs of axle brake system,
- after repairs of parking brake system.

Before the adjustment, make certain that the axle brake is correctly adjusted and is functioning properly.

Adjustment of parking brake cable tension

- ➔ Connect the manure spreader to tractor. Park manure spreader and tractor on level surface.
- ➔ Place securing chocks under one wheel of manure spreader.
- ➔ Fully unscrew the bolt of the brake crank mechanism (1) – figure (5.7), (anticlockwise).
- ➔ Loosen nuts (6) on U-shaped clamps of steel cable
- ➔ Tighten cable and tighten clamps.
 - ⇒ Length of parking brake cables should be so selected that at total release of working and parking brake the pulley block would be loose and hanging by 1 - 2 cm compared to fully tensioned cables.

Replacing the parking brake cable

- ➔ Connect the manure spreader to tractor. Park manure spreader and tractor on level surface.
- ➔ Place securing chocks under one wheel of manure spreader.
- ➔ Fully unscrew the bolt of the brake crank mechanism (1).
- ➔ Dismantle shackle (6) at the ends of the cable.
- ➔ Unlock pin and guide roller of pulley block (4).
- ➔ Unlock and dismount pins in pulley block (4) and in brake crank mechanism (1).
- ➔ Loosen the nuts (6) of U-shaped clamps (5).
- ➔ If necessary, dismount guide rollers (3).
- ➔ Dismantle cable.
- ➔ Clean parking brake components, lubricate crank mechanism and pins of cable guide rollers (3).
- ➔ Install new cable.
- ➔ After the first loading of cable, re-check the condition of cable ends, correct if necessary.

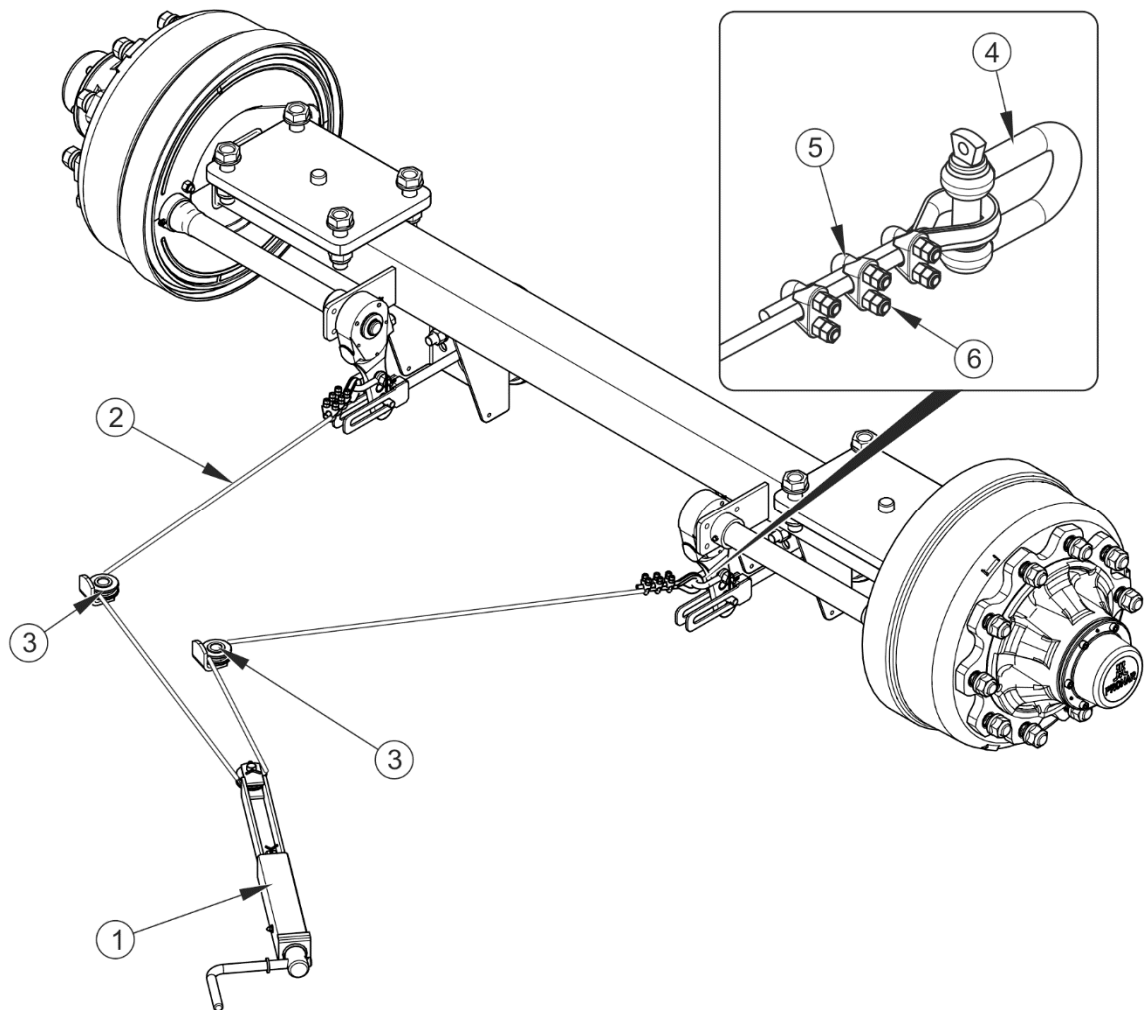

FIGURE 5.7 Adjustment of parking brake cable tension

(1) brake crank mechanism, (2) steel cable, (3) cable roller, (4) shackle, (5) U-shaped clamp, (6) clamp nuts

Installation of steel cable



ATTENTION

Clamp jaws must be placed on the load bearing side of cable - see Figure (5.8).

- ➔ Secure cable ends by means of heat shrink tubing (5).
- ➔ Install thimble (3) on cable (1).
- ➔ Install clamp jaws (2) and tighten nuts (4) using proper tightening torque.
- ➔ Clamp jaws must be placed on the load bearing side of cable - see figure (5.8).

➔ The first clamp should be placed directly on the thimble.

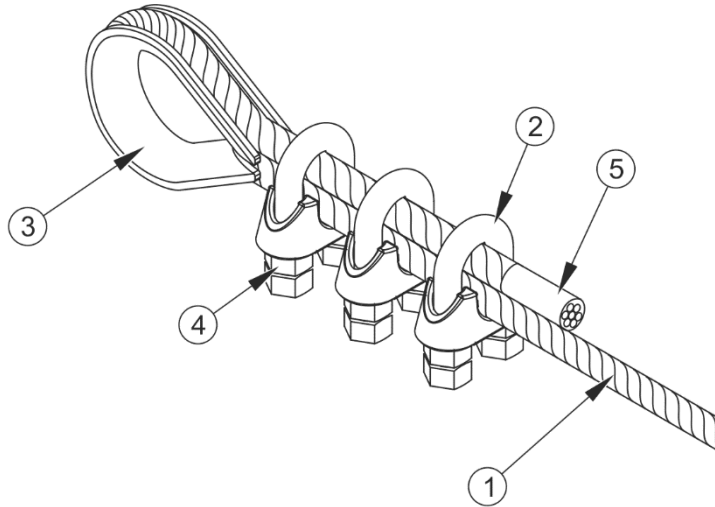

FIGURE 5.8 Installation of steel cable clamps

(1) steel cable, (2) clamp jaw, (3) thimble, (4) nut, (5) heat shrink tubing

5.3 PNEUMATIC SYSTEM MAINTENANCE

5.3.1 PRELIMINARY INFORMATION

Work connected with repair, replacement or regeneration of system components (brake cylinders, conduits, control valve, braking force regulator, etc.) should be entrusted to specialist establishments, having the appropriate technology and qualifications for this type of work.



DANGER

Do NOT use the manure spreader when braking system is unreliable.

The duties of the operator connected with the pneumatic system include:

- checking tightness and visual inspection of the system,
- cleaning the air filter (filters),
- draining water from air tank,
- cleaning drain valve,

- cleaning and maintaining pneumatic conduit connections,
- replacement of pneumatic conduit.

5.3.2 CHECKING AIR TIGHTNESS AND VISUAL INSPECTION OF PNEUMATIC SYSTEM

Checking air tightness of pneumatic system

- ➔ Connect the manure spreader to tractor.
- ➔ Immobilise tractor and manure spreader with parking brake, place the wheel chocks under the manure spreader wheels.
- ➔ Start tractor in order to supplement air in manure spreader braking system tank.
 - ⇒ In single conduit systems air pressure should amount to approx. 5.8 bar.
 - ⇒ In double conduit systems air pressure should amount to approx. 8 bar.
- ➔ Turn off tractor engine.
- ➔ Check system components by releasing brake pedal in tractor.
 - ⇒ Give particular attention to conduit connections and brake cylinders.
- ➔ Repeat the system check with depressed tractor brake pedal.
 - ⇒ The help of a second person is required.

In the event of the appearance of leaks, compressed air will escape at the places of damage, with a characteristic hiss. Lack of system tightness may be also detected by covering checked elements with washing fluid or other foaming preparations, which will not react aggressively with system components. Damaged components should be replaced or repaired. If leaks appear at connections then tighten the connections. If air continues to escape, replace connection components or seals.



Checking tightness of pneumatic system:

- after travelling the first 1,000 km,
- each time after making repairs or changing system components,
- annually.

Visual inspection of the system

During tightness inspection attention should additionally be given to technical condition and degree of cleanness of the system components. Contact of pneumatic conduit seals etc. with oil, grease, petrol etc. may cause damage and accelerate the ageing process. Bent, permanently deformed, cut or worn conduits should be replaced.



Visual inspection of the system

- Conduct inspection of system at the same time as when checking tightness.



ATTENTION

Repair, exchange or regeneration of pneumatic system components may only be performed in a specialised workshop.

5.3.3 CLEANING THE AIR FILTERS



DANGER

Before proceeding to dismantle filter, reduce pressure in supply conduit. While dismantling the slide lock, hold the cover with the other hand. Stand away from filter cover vertical direction.

Depending on manure spreader working conditions, but not less than once in three months, take out and clean air filter elements, which are located in pneumatic system connection conduits. Filter elements are used many times and are not subject to change unless they are mechanically damaged.

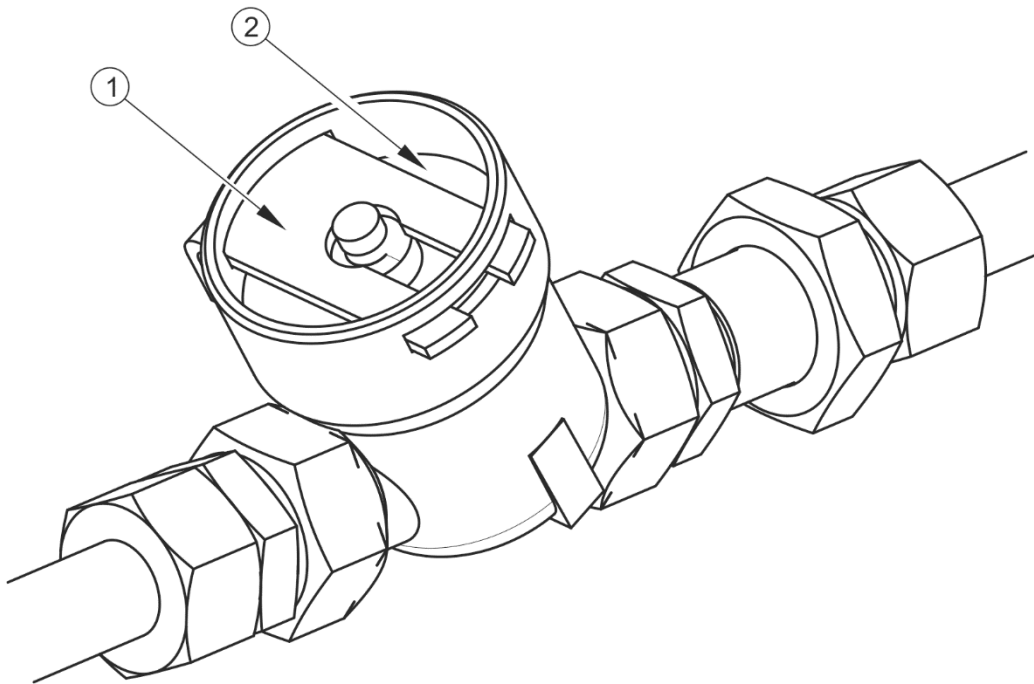

FIGURE 5.9 Air filter

(1) securing slide lock, (2) air filter cover

Required maintenance activities:

- ➔ Reduce pressure in supply conduit.
 - ⇒ Reduction of pressure in conduit may be achieved by pressing the head of the pneumatic connection until resistance is felt.
- ➔ Slide out securing slide lock (1) – figure (5.9).
 - ⇒ Hold the filter cover (2) with the other hand. After removing slide lock, the cover is pushed off by the spring located in the filter housing.
- ➔ The filter element and the filter body should be carefully washed out and blown through with compressed air. Assembly should be done in reverse order.



Cleaning the air filter (filters):

- every 3 months of use,

5.3.4 DRAINING WATER FROM AIR TANK

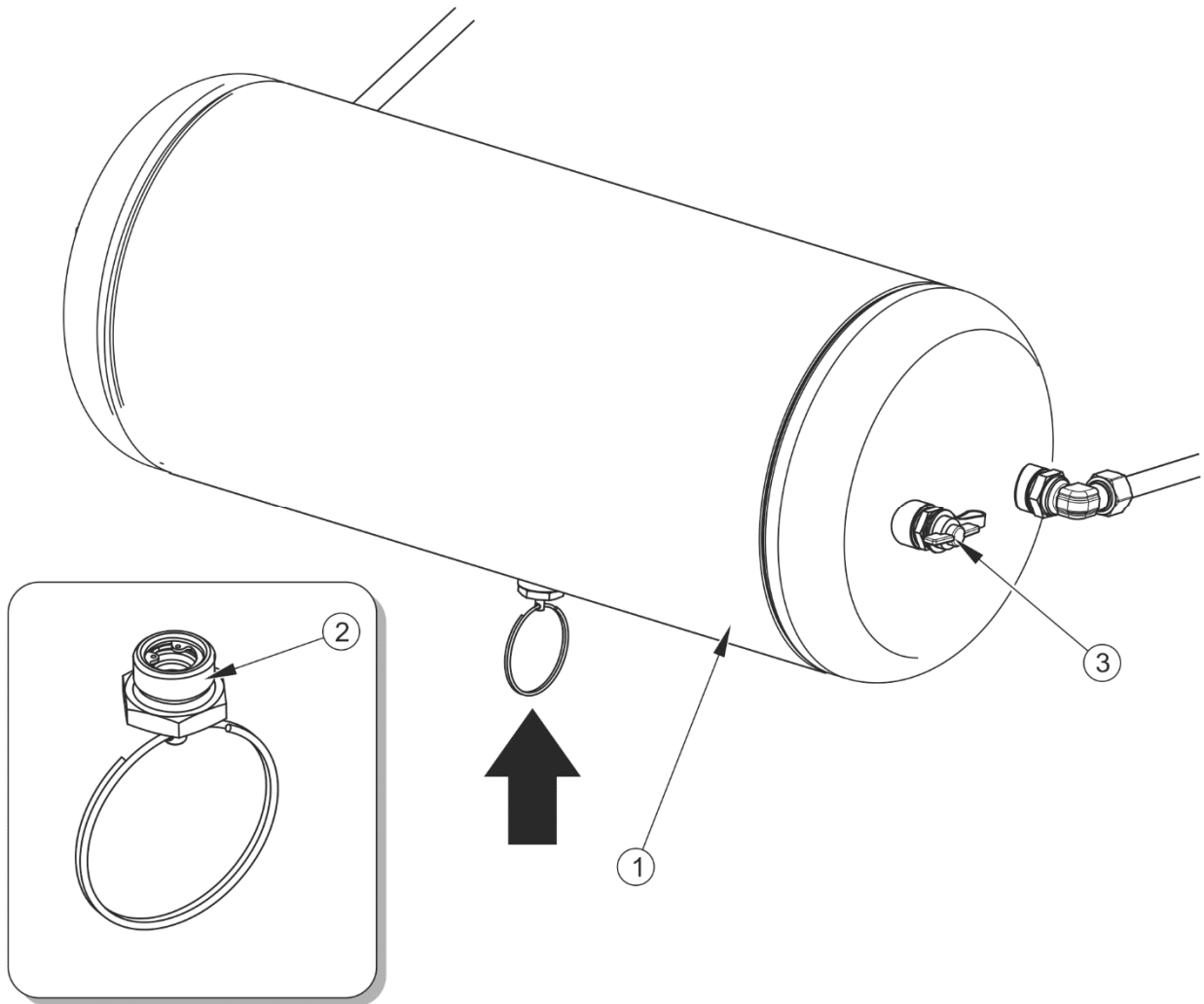



FIGURE 5.10 Draining water from air tank

(1) air tank, (2) drain valve



Draining water from air tank:

- every seven days of use.

Required maintenance activities:

- ➔ Open out drain valve (2) located in the lower part of tank (1).
 - ⇒ The compressed air in the tank causes the removal of water to the exterior.

- ➔ Released valve stem should automatically close and stop flow of air from the tank.
 - ⇒ If the valve stem resists returning to its position, then the whole drain valve must be unscrewed and cleaned or replaced (if it is damaged) - see section 5.3.5.

5.3.5 CLEANING THE DRAIN VALVE



DANGER

Release air from the air tank before dismantling drain valve.

Required maintenance activities:

- ➔ Reduce pressure in air tank.
 - ⇒ Reduction of pressure in tank is achieved by tilting the drain valve stem.
- ➔ Unscrew valve.
- ➔ Clean valve, blow with compressed air.
- ➔ Change copper seal.
- ➔ Screw in valve, fill tank with air and check tank tightness.



Cleaning valve:

- every 12 months (before winter period).

5.3.6 CLEANING AND MAINTAINING PNEUMATIC CONDUIT CONNECTIONS AND PNEUMATIC SOCKETS



DANGER

Unreliable and dirty manure spreader connections may cause unreliability and faulty functioning of braking system.

In the event of damage to cover or seal, change these elements for new reliable elements. Contact of pneumatic connector seals with oils, grease, petrol etc. may cause damage and accelerate ageing process.

If the manure spreader is unhitched from the tractor, connectors should be protected by caps or placed in their designated sockets. Before the winter period it is recommended to preserve the seal with special preparations (e.g. silicon grease for rubber elements).

Each time before hitching the machine, inspect technical condition and cleanness of connectors and sockets in tractor. If necessary, clean or repair tractor sockets.



Checking the manure spreader connections:

- each time before hitching manure spreader to tractor.

5.3.7 REPLACEMENT OF PNEUMATIC CONDUIT

Pneumatic conduits should be replaced when permanently deformed, cut or frayed.

Required maintenance activities:

- ➔ Release all pressure from the system.
 - ⇒ Reduction of pressure is achieved by tilting the drain valve mandrel.
- ➔ Remove the pneumatic conduit by loosening the nut (2).
- ➔ Fit the new conduit.
 - ⇒ The interior of the conduit should be clean.
 - ⇒ The ends of the pneumatic conduit (1) must be cut exactly at right angles.
 - ⇒ Clamping ring (3) should be fitted according to figure (5.11).
 - ⇒ Reinforcing sleeve (4) of the conduit must be thoroughly depressed.
- ➔ Check tightness of connections in accordance with Chapter (5.3.2).

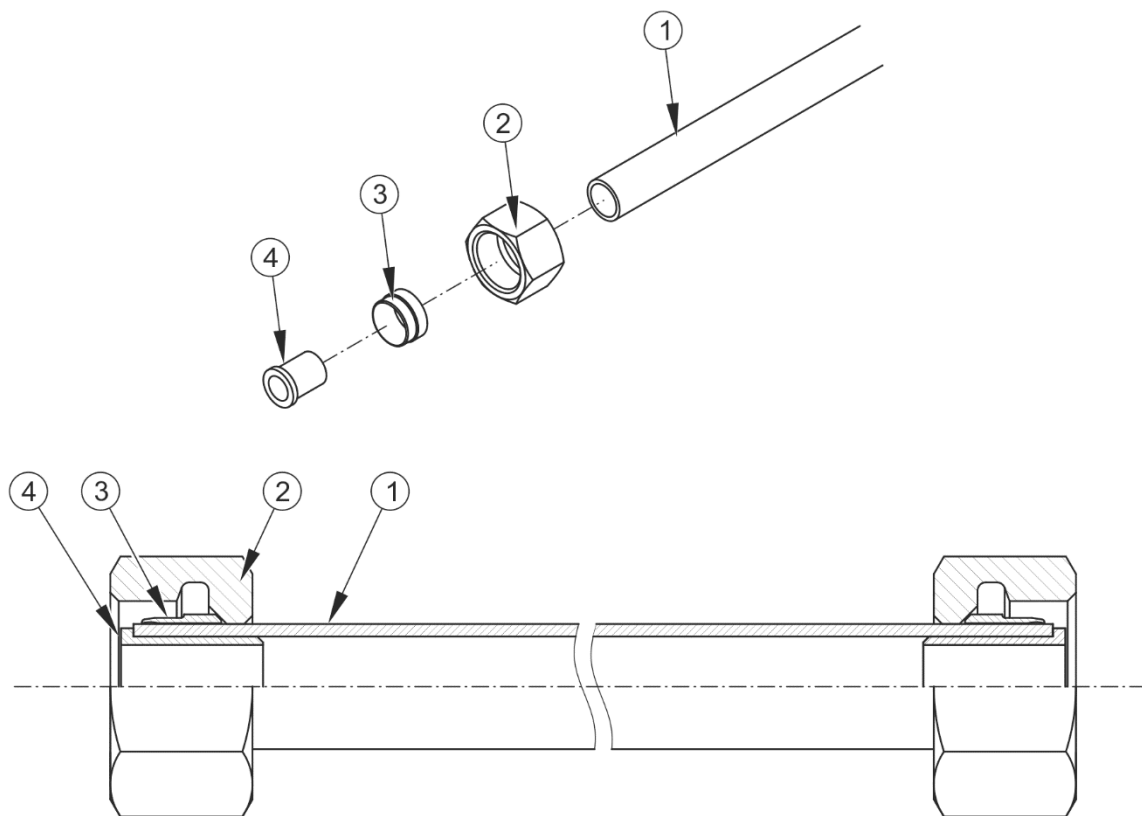

FIGURE 5.11 Installation of pneumatic conduit

(1) pneumatic conduit, (2) connecting nut (3) clamping ring, (4) reinforcing sleeve

5.4 HYDRAULIC SYSTEM OPERATION

ATTENTION



Manure spreader with a leaking hydraulic system must **NOT** be used.

The condition of hydraulic system should be inspected regularly while using the manure spreader.

ATTENTION



The hydraulic system is under high pressure when operating.

Regularly check the technical condition of the connections and the hydraulic conduits.

Use the hydraulic oil recommended by the Manufacturer. Never mix two types of oil.

Always adhere to the principle that the oil in the manure spreader hydraulic system and in the tractor hydraulic system are of the same type. Application of different types of oil is not

permitted. In a new manure spreader, the hydraulic system is filled with L HL32 Lotos hydraulic oil.

The manure spreader's hydraulic system should be completely tight sealed. Checking tightness of the hydraulic system involves connecting the machine with the tractor and activating the floor conveyor several times. In the event of confirmation of an oil leak on hydraulic conduit connections, tighten connections, and if this does not remedy faults then change conduit or connection elements. If oil leak occurs beyond connection, the leaking line of the system should be changed. Change of sub-assemblies is equally required in each instance of mechanical damage.

TABLE 5.2 L-HL32 Lotos hydraulic oil characteristics

ITEM	NAME	VALUE
1	ISO 3448VG viscosity classification	32
2	Kinematic viscosity at 40°C	28.8 – 35.2 mm ² /s
3	ISO 6743/99 quality classification	HL
4	DIN 51502 quality classification	HL

If it is necessary to change hydraulic oil for another oil, check the recommendations of the oil Manufacturer very carefully. If it is recommended to flush the system with the appropriate preparation, then comply with these recommendations. Attention should be given, so that chemical substances used for this purpose do not damage the materials of the hydraulic system.



Hydraulic conduits should be replaced after 4 years of manure spreader use.
Detailed tightness and technical condition inspection of hydraulic system should be made at least annually.

The oil used in the hydraulic system is not classified as a dangerous substance, however long-term action on the skin or eyes may cause irritation. In the event of contact of oil with skin wash the place of contact with water and soap. Do NOT apply organic solvents (petrol, kerosene). Contaminated clothing should be changed to prevent access of oil to skin. In the event of contact of oil with eye, rinse with large quantity of water and in the event of the occurrence of irritation consult a doctor. Hydraulic oil in normal conditions is not harmful to

the respiratory tract. A hazard only occurs when oil is strongly atomised (oil vapour), or in the case of fire during which toxic compounds may be released. Oil fires should be quenched with the use of carbon dioxide, foam or extinguisher steam.

5.5 MAINTENANCE OF MANURE SPREADER GEARS

Maintenance of the adapter drive gear and the floor conveyor drive gear involves checking gear oil level in the inspection opening, topping up with gear oil and gear oil change.



Check oil level in the gears in the transparent inspection opening before each start of the machine. Turn off the gears and wait until oil cools down before changing oil.

Oil in both gears should be changed after the first 50 working hours and then every 600 working hours.

Oil change should be conducted at working temperature, when the machine has worked for several minutes. Then, possible contamination in the gear is mixed with the oil and is drained out with it.



WARNING

There are two different options of the adapter drive gear offered by the manufacturer:

“option 1” – with the drain plug located in the central gear.

“option 2” – with the drain plugs located in the central and side gears.

POSITION OF GEAR		TYPE OF GREASE	QUANTITY
A	Adapter gear mechanism – “option 1”	SAE 90 EP (API GL-5 SAE 80W/90)	7l
A	Adapter gear mechanism – “option 2”		10l
B	Feeding mechanism (NV161/1, NV161/2, NV161/3)		3.8l
B	Feeding mechanism (NV161/4 NV161/5)		6.6l



DANGER

When checking oil level and changing oil, use appropriate personal protection equipment i.e. protective clothing, safety shoes, gloves, safety goggles. Avoid contact of skin with oil.

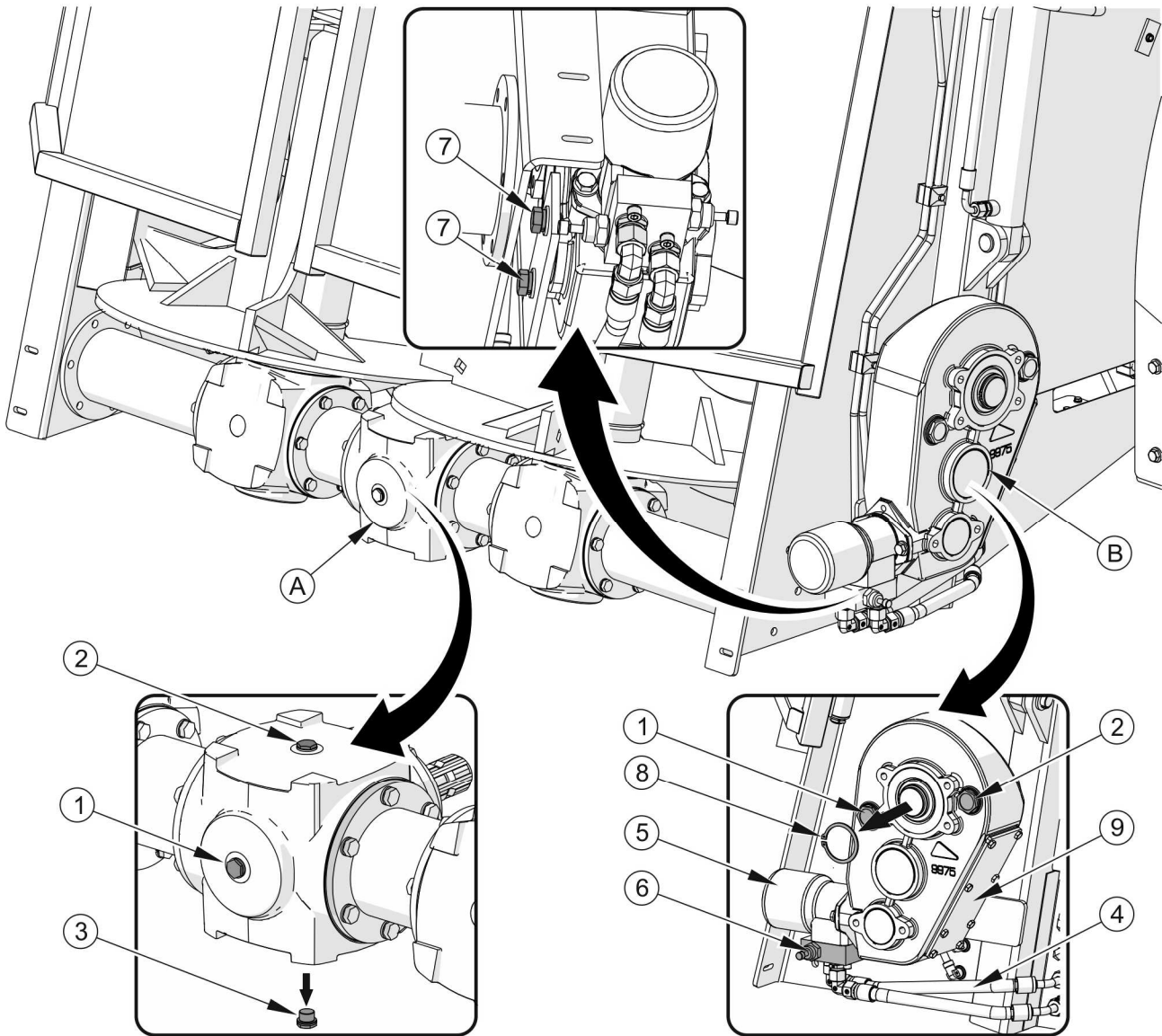

FIGURE 5.12 Oil inspection and filling points on the gear

(A) adapter drive gear, (B) floor conveyor drive gear, (1) inspection opening, (2) filler plug, (3) drain plug, (4) hydraulic hose, (5) hydraulic drive, (6) valve, (7) screw, (8) retaining ring, (9) side cover

**WARNING**

Do not overfill. Too much oil may result in overheating of the gears.

In case of leakage inspect the sealing and check the oil level. Operating the gears with low oil level or without oil may result in permanent damage of their components.

Changing oil in adapter gear (A)

- ➔ Start the adapter drive and let it run for a couple of minutes (in case the machine was not operating and the gear is cold).
- ➔ Stop the adapter drive and turn off the engine of the tractor.
- ➔ Prepare a container for oil. Open the filler plug (2) and the drain plug (3) on the bottom of the central gear (option 1) or the drain plugs in three gears (option 2) and drain oil into the container.

**WARNING**

When draining oil from the adapter gear with the drain plug (3) located only in the central gear wait until all oil is drained from the side gears.

- ➔ Check the drain plug seal (3), replace if necessary and close the drain plug.
- ➔ Set the machine horizontally and fill the gear with gear oil up to the half of the inspection opening (1).

**WARNING**

When filling the gears, gear oil should get to the side gears, therefore add oil to the correct level stepwise, controlling the oil level periodically until it stabilizes.

Changing oil in floor conveyor drive gear (B)**NOTE**

Changing oil in the floor conveyor drive gear is easiest with the use of an oil suction pump.

In case you do not have any oil suction pump, it is necessary to disassemble the gear. To drain oil, the gear can be rotated relative to the shaft, so the filler plug (2) is located on the bottom, however this is not possible for some models and equipment options.

- ➔ Remove two hydraulic hoses (4) from the hydraulic drive valve (5) or remove the valve (6).
- ➔ Remove the screws (7) securing the gear to the hopper.
- ➔ Disassemble or rotate the gear. When disassembling, remove the retaining ring from the shaft (8).
- ➔ Prepare a container and drain oil through the filler plug (2).
- ➔ Reinstall the gear in the spreader.

**NOTE**

It is possible to drain oil from the conveyor gear (B) through the side cover (9), however the seal may be damaged in the process. If it is the case, replace the seal.

- ➔ Set the machine horizontally and fill the gear with gear oil up to the half of the inspection opening (1).
- ➔ Check the plug seal (2), replace if necessary and close the plug.

5.6 MANURE SPREADER LUBRICATION

Manure spreader lubrication must be carried out in places indicated in figures (5.13), (5.14) and (5.15) and also detailed in table (5.4). The manure spreader is equipped with grease nipples facilitating maintenance and marked with yellow labels (item 11 – table (2.1)).

Manure spreader lubrication should be performed with the aid of a manually or foot operated grease gun, filled with recommended grease. Before commencing work insofar as is possible remove old grease and other contamination. Remove and wipe off excess oil or grease.

TABLE 5.3 Lubrication schedule

ITEM	LUBRICATION POINT	NUMBER OF LUBRICATION POINTS	TYPE OF GREASE	FREQUENCY
1	Hub bearings	2	A	24M
2	Drawbar eye	1	B	14D
3	Axle expander shaft sleeves	2	A	3M
4	Parking brake mechanism	1	A	6M
5	Brake expander arm	4	A	3M
6	Drive shaft bearings	2	A	10H
7	Surface of multi-splined shaft	1	A	14D
8	Tightening mechanism wheel pin (NV161/1, NV161/2, NV161/3)	2	A	10H
9	Articulated joints of shafts	4	A	50H
10	Bearings of the wormshaft line connector	3	A	12M
11	Tailgate hinges	2	C	3M
12	Parking brake guide roller pins	2	A	6M
13	Tightening mechanism wheel pin (NV161/4, NV161/5)	4	A	10H
14	Support mechanism	1	A	3M
15	PTO shaft	**	**	**
16	The upper adapter bearings	2	A	10H

** - For detailed information on operation and maintenance please refer to the user's manual attached to the shaft.

lubrication periods – M month, D – days, H – working hour

Parts that should be lubricated with machine oil should be wiped with dry clean cloth and then a small quantity of oil should be applied to surfaces (using oil can or brush). Wipe off excess oil.

Change of grease in hub bearings should be entrusted to specialised service points, equipped with the appropriate tools. According to the recommendations of the axle Manufacturer, dismantle the entire hub, remove the bearing and individual sealing rings. After careful washing and inspection, mount lubricated elements. If necessary, bearing and seals should be replaced with new parts. Lubrication of axle bearings shall be performed at least once in 2 years or every 50,000 km. In the event of intensive use, lubrication should be performed more frequently.

	<p>When using the manure spreader the user is obliged to observe lubrication instructions according to attached schedule. Excess oil or grease creates deposits of additional contaminants in places requiring lubrication, therefore it is essential to keep individual machine elements clean.</p>
--	---

TABLE 5.4 Recommended lubricants

MARKING ACCORDING TO TAB. (5.4)	DESCRIPTION
A	machine general-purpose grease (lithium, calcium grease),
B	permanent grease for heavily loaded elements with addition of MOS ₂ or graphite
C	ordinary machine oil, silicon grease in aerosol
D	grease for chains

Empty grease or oil containers should be disposed of according to the recommendations of the lubricant Manufacturer.

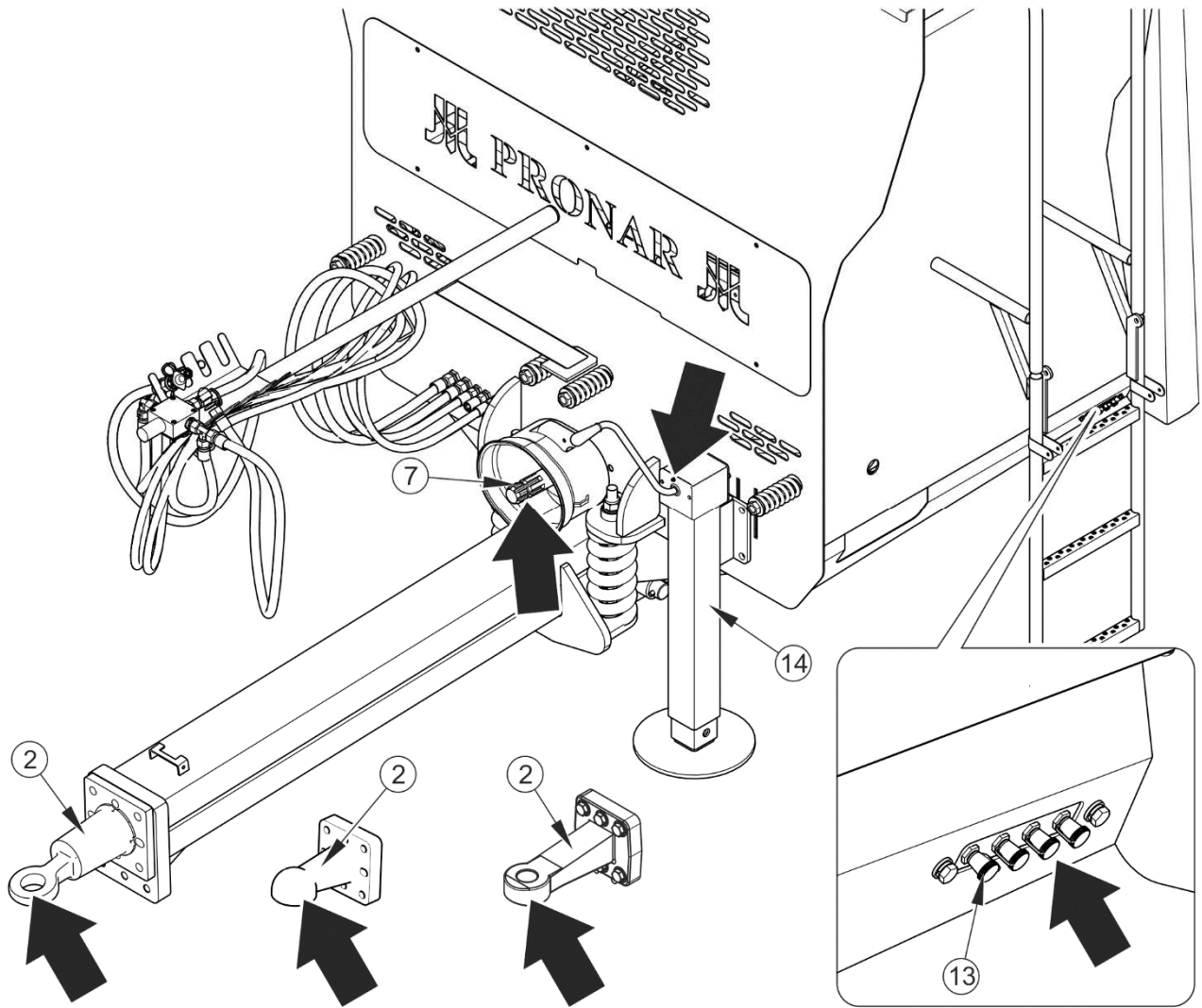

FIGURE 5.13 Lubrication points on the manure spreader

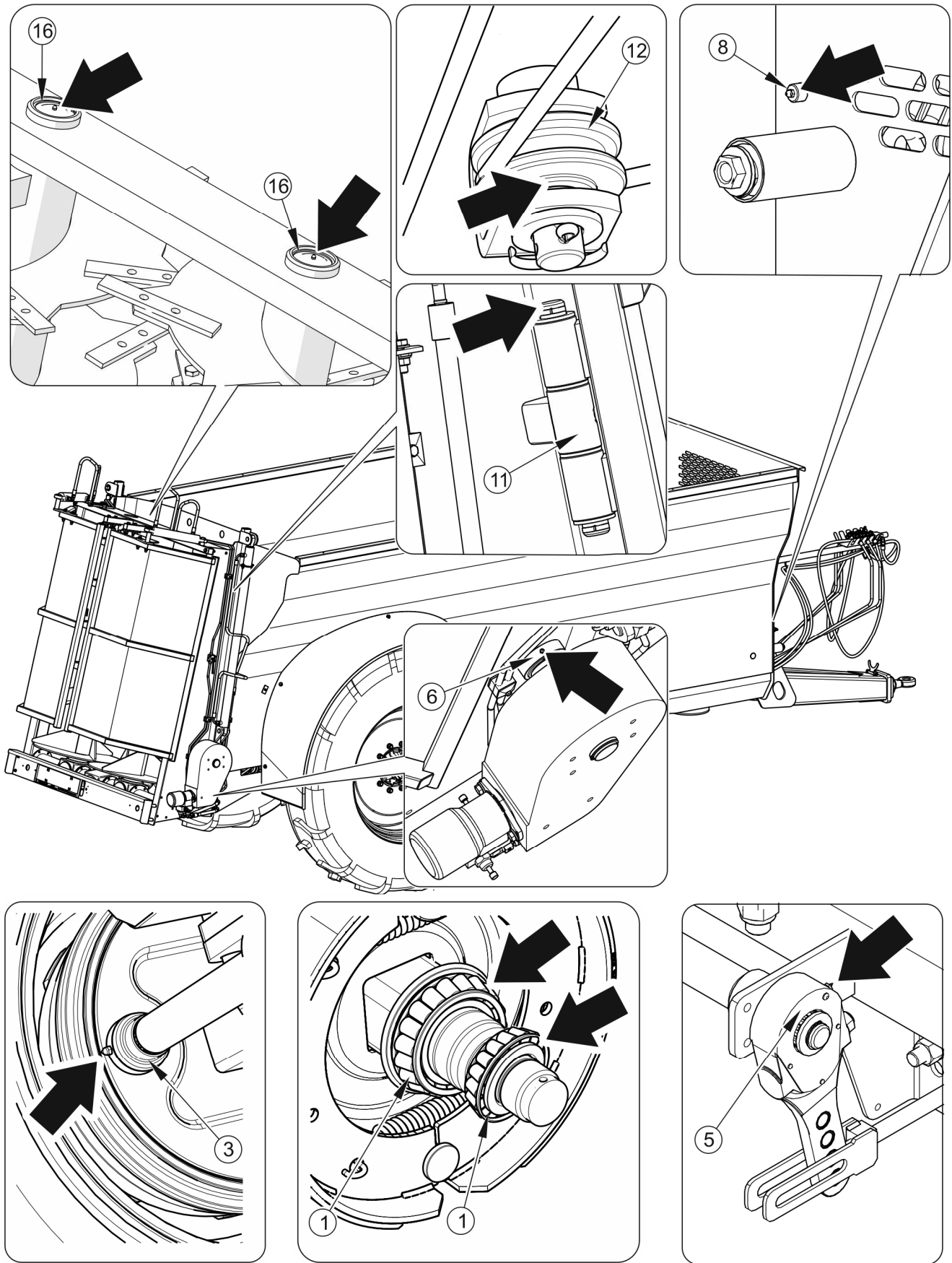

FIGURE 5.14 Lubrication points on the manure spreader

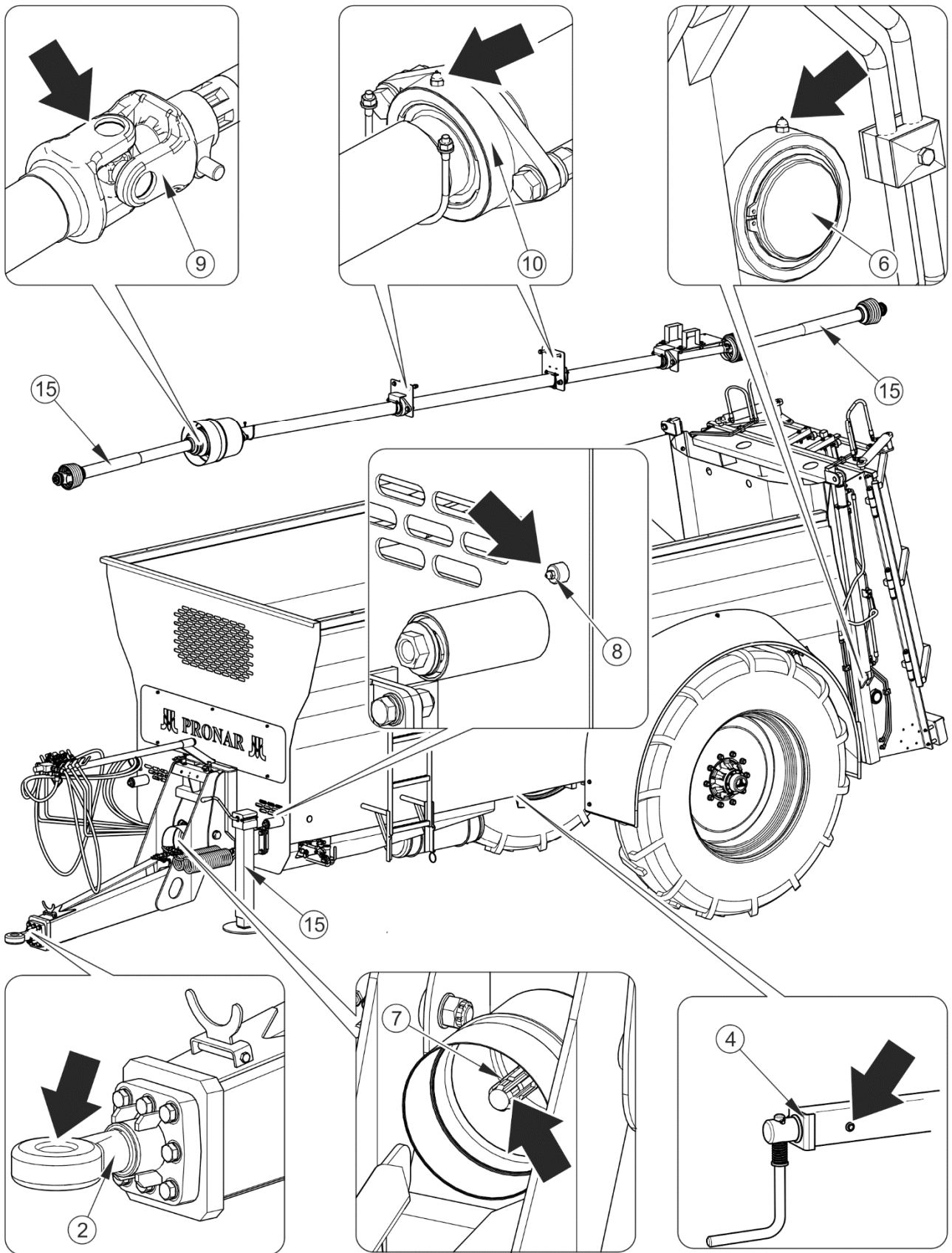

FIGURE 5.15 Lubrication points on the manure spreader

5.7 CHECKING AND ADJUSTMENT OF TENSION OF FLOOR CONVEYOR CHAINS

Tension of floor conveyor chains must be checked daily, in particular, at the beginning of the conveyor's working period.

Looseness of chains, measured by lifting them perpendicularly to movement direction, halfway along the load box length, should be as small as possible. Tension of chains is adjusted with adjustment bolts located in the front section of the manure spreader.

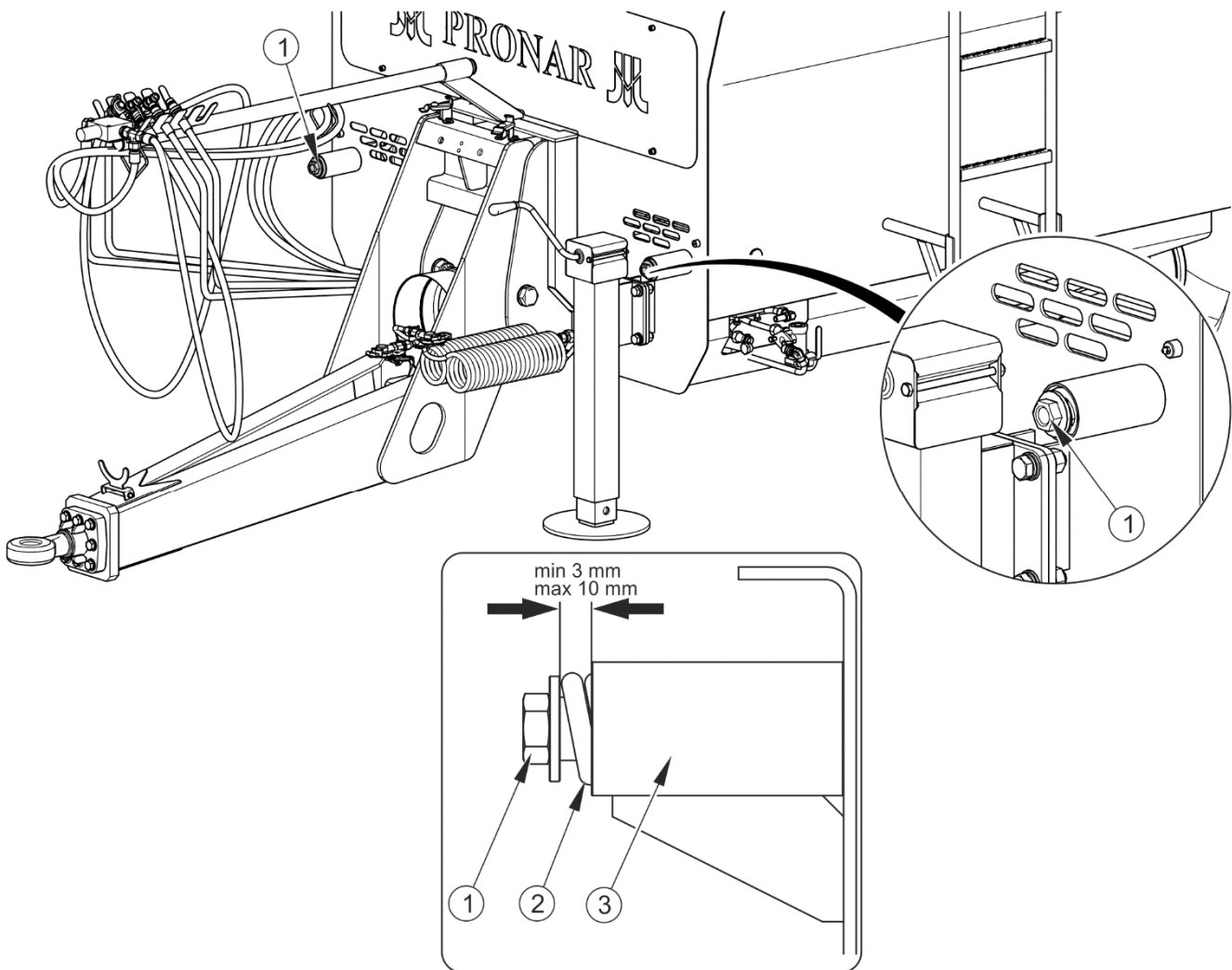

FIGURE 5.16 Adjusting the floor conveyor tension

(1) adjusting screw, (2) tension spring, (3) spring sleeve

**ATTENTION**

All conveyor chains must be equally tensioned.

Excessive looseness of conveyor chain may lead to serious damage to the manure spreader and pose a direct threat to the machine operators or other persons.

5.8 MANURE SPREADER CLEANING

Carefully remove the remains of manure from the manure spreader daily after finished work. Before using pressure washer the user is obliged to acquaint himself with the operating principles and recommendations concerning safe use of this equipment.

Manure spreader cleaning guidelines

- ➔ Immobilise manure spreader and tractor with parking brake, place chocks under manure spreader wheel.
- ➔ Turn off tractor engine and remove key from ignition.
- ➔ Secure tractor against access of unauthorised persons.
- ➔ Clean the manure spreader with strong water jet and leave to dry.
 - ⇒ Using pressure washer increases washing effectiveness, but particular care must be taken during work. During washing, washer nozzle may not be closer than 50 cm from the surface being cleaned.
 - ⇒ Water temperature shall not exceed 55°C.
 - ⇒ Using excessive pressure for cleaning may damage lacquer coating.
 - ⇒ Do not direct water jet directly at system and equipment elements of manure spreader i.e. control valve, brake cylinders, pneumatic, electric and hydraulic plugs, lights, electrical connections, information and warning decals, data plate, conduit connections and lubrication points etc. Great water jet pressure may damage these elements.
- ➔ For cleaning and maintenance of plastic coated surfaces it is recommended to use clean water or special preparations designed for this purpose.

- ➔ Do not apply organic solvents, preparations of unknown origin or other substances, which may cause damage to lacquered, rubber or plastic surfaces. In the event of doubt it is recommended to make a test on an unseen surface area.
- ➔ Surfaces smeared with oil or grease should be cleaned by application of benzene or other degreasing agents and then washed with clean water with added detergent. Comply with recommendations of the Manufacturer of cleaning agents.
- ➔ Detergents should be kept in original containers, optionally in replacement containers, but very clearly marked. Preparations may not be stored in food and drink containers.

DANGER

Carefully read the instructions for application of detergents and maintenance preparations.

While washing with detergents wear appropriate protective clothing and goggles protecting against splashing.

Switch tractor engine off and disengage PTO shaft before cleaning the machine and standing on the chain conveyor strips.

Before climbing on to the load box, make sure unauthorised persons do not have access to the tractor, disconnect PTO shaft and disconnect hydraulic system conduits from the tractor.

Exercise caution when climbing on top of the load box.

While climbing on to the manure spreader's load box, the manure spreader must be absolutely motionless.



- ➔ Ensure cleanliness of elastic conduits and seals. The plastic from which these elements are made may be susceptible to organic substances and some detergents. As a result of long-term reaction of some substances, the ageing process may be accelerated and risk of damage increased. Rubber elements should be maintained with the aid of special preparations after previous thorough washing.
- ➔ Observe environmental protection principles and wash manure spreader in a place designed for this purpose.

- ➔ Cleaning and drying of the manure spreader must take place at temperatures above 0°C.
 - ⇒ In winter, freezing water may cause damage to paint coating or machine elements.

5.9 PREPARATION FOR END OF SEASON

After finishing fieldwork the manure spreader must be properly prepared for winter storage. In order to do this:

- ➔ carefully remove the remains of manure and wash the manure spreader,
- ➔ check technical condition of: bearings, shields, chains, electrical system, pneumatic system and indicators,
- ➔ grease all inspection points of the manure spreader,
 - ⇒ Conveyor chains should be cleaned with petroleum and oiled after drying
- ➔ check air pressure in tyres,
- ➔ corroded or damaged surface should be cleaned and properly protected with a thin layer of grease, anticorrosion preparation or priming paint,
- ➔ secure PTO shaft, check condition of its shields, grease moving elements of PTO shaft,
- ➔ check visually the components which wear most frequently and replace them if necessary,
- ➔ tyres should be preserved at least once a year using generally available substances for this purpose.

5.10 PREPARATION FOR THE BEGINNING OF A NEW FIELDWORK SEASON

- ➔ Check technical condition of bearings, shields, chains.
- ➔ Check spreader unit blades and replace them if necessary.
- ➔ Check technical condition of the electrical system; Check whether lights work correctly.
- ➔ Check leaktightness of pneumatic system and hydraulic system.
- ➔ Check state of wear of hydraulic hoses. Immediately replace worn or damaged hydraulic hoses.
- ➔ Check technical condition of PTO shaft, its shields and securing chains.
- ➔ Check oil level in the spreader unit drive gear and the floor conveyor drive gear.
- ➔ Grease all inspection points of the manure spreader,
- ➔ Check air pressure in tyres,
- ➔ Check tension of the floor conveyor chain, adjust if necessary.
- ➔ Check setting of brake lever, adjust if necessary.
- ➔ Check condition of bolt connections, tighten if necessary.
- ➔ Check degree of drawbar wear.
- ➔ Check drawbar and frame for scratches and fractures.
- ➔ Check state of wear of the floor conveyor mechanism's strips, if necessary replace them with new ones.

5.11 STORAGE

- ➔ After finishing work, the manure spreader should be thoroughly cleaned and washed.
- ➔ In the event of damage to the lacquer coating clean those places from rust and dirt, degrease and then paint with paint maintaining uniform colour and even thickness of protective coating. Until the time of touch-up painting, the damaged place should be covered with a thin layer of grease, anticorrosion preparation or priming paint.
- ➔ It is recommended to keep the manure spreader in a closed or roofed building.
- ➔ Before longer outdoor storage, it is essential to protect the machine against adverse weather conditions, especially those causing corrosion and accelerated ageing of tyres.
- ➔ In the event of prolonged work stoppage, it is essential to lubricate all elements regardless of the date of the last lubrication.
- ➔ Chains of the spreader unit drive should be taken off, carefully washed and, if suitable for further use, reinstalled and smeared generously with grease.
- ➔ Wheel rims and tyres should be carefully washed and dried. During longer storage it is recommended that every 2 to 3 weeks the machine may be moved a bit so that the place of contact of tyres with ground is changed. The tyres will not be deformed and maintain proper geometry. Also tyre pressure should be inspected from time to time, and if necessary pressure should be increased to appropriate value.
- ➔ PTO shaft for connection with tractor should be stored in the horizontal position.

5.12 MAINTENANCE OF ELECTRICAL SYSTEM AND WARNING ELEMENTS

5.12.1 PRELIMINARY INFORMATION

Work connected with the repair, change or regeneration of electrical system components should be entrusted to specialist establishments, having the appropriate technology and qualifications for this type of work.

The responsibilities of the user are limited to:

- ➔ technical inspection of electrical system and reflectors,
- ➔ Changing bulbs



ATTENTION

Do NOT travel with out of order lighting system. Damaged lamp lenses, and burned-out bulbs must be replaced immediately before travelling. Lost or damaged reflective lights must be replaced.

Required maintenance activities:

- ➔ Connect manure spreader to tractor with appropriate connection lead.
 - ⇒ Check if the connection lead is reliable. Check connection sockets in tractor and manure spreader.
- ➔ Check completeness and technical condition of machine lights.
- ➔ Check completeness of all reflectors.
- ➔ Check correct mounting of the slow-moving vehicle warning sign holder.
- ➔ Before driving on to public road check that the tractor is equipped with a warning reflective triangle.



Checking technical condition of electrical system:

- each time while connecting the manure spreader.

**TIP**

Before driving off, make certain that all lamps and reflective lights are clean.

5.12.2 CHANGING BULBS

Compatible bulbs are shown in table (5.6). All light lenses are secured by screws and it is not necessary to dismantle whole lamp or manure spreader subassemblies.

TABLE 5.5 List of bulbs

LAMP	LAMP TYPE	BULB / QUANTITY IN 1 LAMP	NUMBER OF LAMPS
Rear left lamp assembly	W21L	R10W / 1 pc P21W / 2 pcs	1
Rear right lamp assembly	W21P	R10W / 1 pc P21W / 2 pcs	1
Licence plate light	LT-120	C5W-SV8.5 / 1 pc	1

**ATTENTION**

The supply voltage of the manure spreader's electrical system is 12V.

5.13 TIGHTENING TORQUE FOR NUT AND BOLT CONNECTIONS

Unless other tightening parameters are given, during maintenance-repair work apply appropriate torque to tighten nut and bolt connections. Recommended tightening torque values for the most frequently used bolt and nut connections are given in table (5.7). Given values apply to non-lubricated steel bolts.

TABLE 5.6 Tightening torque for nut and bolt connections

THREAD METRIC	5.8 ⁽¹⁾	8.8 ⁽¹⁾	10.9 ⁽¹⁾
	MD [Nm]		
M10	37	49	72
M12	64	85	125
M14	100	135	200
M16	160	210	310
M20	300	425	610
M24	530	730	1,050
M27	820	1,150	1,650
M30	1,050	1,450	2,100

⁽¹⁾ – resistance class according to DIN ISO 898 standard, (M_D) – tightening torque, (d) thread diameter

Hydraulic conduits should be tightened using torque of 50 – 70 Nm.

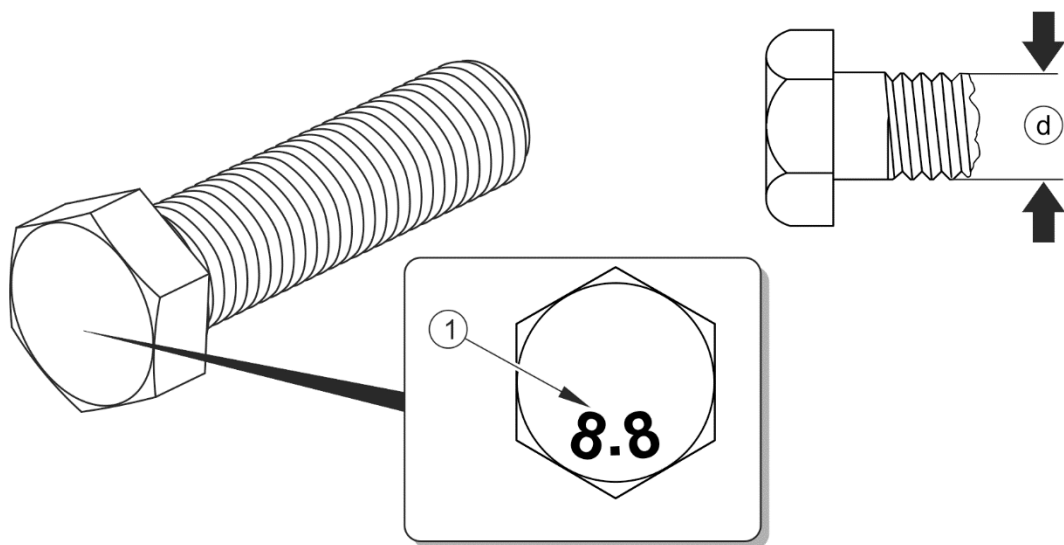

FIGURE 5.17 Bolt with metric thread

(1) bolt strength class, (d) thread diameter

5.14 TROUBLESHOOTING

TABLE 5.7 **Faults and means of remedying them**

FAULT	CAUSE	REMEDY
Conveyor knocking	Excessive lengthening of conveyor chains. Improperly adjusted tension of conveyor chains.	Check tension of chains and adjust according to section 5.7.
Spreader unit is blocked	Excessive floor conveyor speed.	Reduce floor conveyor speed and momentarily change conveyor movement direction.
Problem with moving off	Brake system conduits/conduit not connected.	Connect brake conduits.
	Damaged brake system connection conduits.	Replace conduits with new ones.
	Leaking connections.	Tighten, replace washers or seal set.
	Parking brake is applied.	Release parking brake.
Poor reliability of braking system	Insufficient pressure in the system.	Check pressure on tractor pressure gauge, wait till compressor fills tank to required pressure.
	Damaged air compressor in tractor	Repair or replace.
	Damaged brake valve in tractor.	Repair or replace.
	Leaking system conduits or connections.	Check system for tightness.
Noise in axle hubs	Excessive bearing slackness.	Check slackness and adjust if needed.
	Damaged bearings.	Change bearing together with sealing ring.

FAULT	CAUSE	REMEDY
Excessive heating of axle hubs	Incorrectly adjusted main brake.	Regulate setting of expander arms
	Incorrectly adjusted parking brake.	Adjust tension of parking brake cables.
	Worn brake linings.	Change brake shoes.
Control system of the chain conveyor does not work	Interrupted oil flow.	Check degree of wear of connector plug. Set the tractor's control valve for pressure.
	Exchanged supply conduits	Exchange the connectors.
Halves of PTO shaft loosen with regard to each other during operation	PTO shaft is too short.	Replace PTO shaft with a longer one.

NOTES

A series of horizontal dotted lines for writing notes.

