



PRONAR SP. Z O.O.

17-210 NAREW, UL. MICKIEWICZA 101A, WOJ. PODLASKIE

TEL.: +48 085 681 63 29

+48 085 681 64 29

+48 085 681 63 81

+48 085 681 63 82

FAX: +48 085 681 63 83

+48 085 682 71 10

USER MANUAL

CHOPPING MOWER

PRONAR KPR700

TRANSLATION OF THE ORIGINAL INSTRUCTION

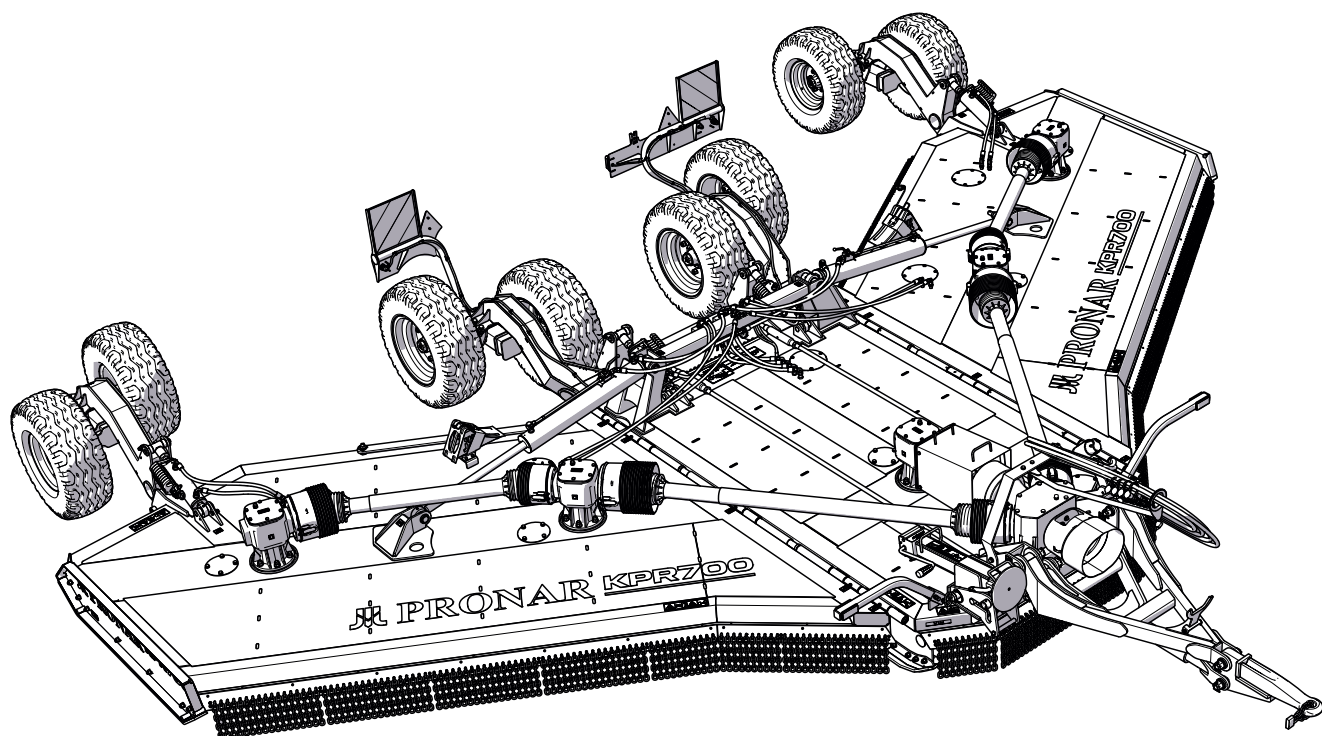

ISSUE 1A

10-2022

PUBLICATION NO. 639.01.UM.1A.EN

EN

Manufacturer's address

*PRONAR Sp. z o.o.
ul. Mickiewicza 101A
17-210 Narew*

Contact phone numbers

*+48,085,681 63 29
+48,085,681 64 29
+48,085,681 63 81
+48,085,681 63 82*

Website

*www.pronar.pl
<https://pronar-recycling.com/pl/>*

Emergency service

*+48,085,682 71 14
+48,085,682 71 93
+48,085,682 71 20
serwis@pronar.pl*

This manual contains important safety and operating instructions for the machine. The manual should be kept near the machine so that it is available for authorized persons.

Keep this manual for future reference. If the manual is lost or damaged, contact the seller or the manufacturer for a duplicate.

Copyright © PRONAR Sp. z o.o. All rights reserved.

The whole of this study is the property of PRONAR Sp. z o.o. and is a work within the meaning of the Act on Copyright and related Rights.

No part of this document may be distributed or copied in any way (electronic, mechanical or otherwise) without the written consent of PRONAR Sp. z o.o.

Table of contents

CHAPTER 1.	
INTRODUCTION.....	1.1
1.1 Dear User.....	1.2
1.2 Rules for using the User's Manual.....	1.4
1.3 Target group.....	1.5
1.3.1 End user (User, Authorized User, Operator).....	1.5
1.3.2 Qualified person (qualified personnel).....	1.6
1.3.3 Service personnel.....	1.7
1.3.4 Unauthorized user.....	1.7
1.4 Symbols and tags used in the manual.....	1.9
1.4.1 Danger.....	1.9
1.4.2 Caution.....	1.9
1.4.3 Advice.....	1.9
1.4.4 Personal protective equipment pictograms.....	1.10
1.4.5 Qualification pictograms.....	1.10
1.4.6 Typography of the User Manual.....	1.11
1.5 Glossary.....	1.13
1.6 Designation of directions in the manual.....	1.15
1.7 Final acceptance.....	1.16
1.7.1 Preliminary information.....	1.16
1.7.2 Checking the machine after delivery.....	1.16
1.7.3 First start-up of the machine.....	1.17
1.8 Environmental hazard.....	1.18
1.9 Personal protective equipment.....	1.19
1.9.1 General.....	1.19
1.9.2 Work clothing.....	1.19
1.9.3 Hearing protectors.....	1.19
1.9.4 Work shoes.....	1.19
1.9.5 Warning vest.....	1.20
1.9.6 Protective gloves.....	1.20
1.9.7 Safety glasses with side shields.....	1.21
1.9.8 Industrial protective helmet.....	1.21
1.9.9 Anti-dust respirator.....	1.22
CHAPTER 2	
GENERAL.....	2.1
2.2 Identification.....	2.2
2.2.2 Machine identification.....	2.2

2.3	Intended use of the machine.....	2.4
2.3.2	Intended use.....	2.4
2.3.3	Expected inappropriate use.....	2.5
2.4	Agricultural tractor requirements.....	2.6
2.4.2	Minimum load on the front axle of the tractor.....	2.7
2.5	Equipment of the machine.....	2.8
2.6	Transport.....	2.9
2.6.2	Trucking.....	2.9
2.6.3	User's transport.....	2.11
2.7	Terms & Conditions of Warranty.....	2.12
2.8	Environmental risk.....	2.14
2.9	Withdrawal from use.....	2.15

CHAPTER 3

SAFETY OF USE.....	3.1
3.1 Safe use.....	3.2
3.2 Safety when hitching the machine.....	3.4
3.3 Safety rules when maintaining hydraulic system.....	3.5
3.4 Safety during transportation.....	3.6
3.5 Maintenance and Cleaning.....	3.8
3.6 Safety during machine operation.....	3.11
3.7 Safe operation of the PTO shaft.....	3.12
3.8 Residual risk.....	3.14
3.9 Information and warning stickers.....	3.16

CHAPTER 4

CONSTRUCTION AND PRINCIPLE OF OPERATION.....	4.1
4.1 Technical characteristics.....	4.2
4.2 Construction general and principle of operation.....	4.4
4.3 Suspension system.....	4.6
4.4 The hydraulic system.....	4.7
4.5 Electrical system.....	4.8
4.6 Powertrain.....	4.9

CHAPTER 4

CONSTRUCTION AND PRINCIPLE OF OPERATION.....	4.1
4.1 Get ready for operation.....	5.2
4.2 Articulated telescopic boom lift adjustment.....	5.4
4.3 The drawbar eye protection.....	5.6
4.4 Carrier loading.....	5.7
4.5 Operation of the mechanical parking stand.....	5.10

4.6	Suspension adjustment operations.....	5.12
4.7	Connecting of a mower with implement carrier (tractor).....	5.16
4.8	Work with the mower.....	5.19
4.9	Connecting and disconnecting of the hydraulic system.....	5.23
4.10	Connecting and disconnecting of the electric system.....	5.25
4.11	Driving on public roads.....	5.26
4.12	Rules for the use of tires.....	5.28
4.13	Cleaning.....	5.29
4.14	Disconnecting of the machine from the carrier.....	5.31
4.15	Storage.....	5.33

CHAPTER 6

PERIODIC INSPECTIONS AND TECHNICAL SERVICE	6.1
6.1 General.....	6.2
6.2 Maintenance and inspection schedule.....	6.3
6.3 Checking plugs and connection sockets.....	6.5
6.4 Measurement of air pressure, check tires and wheels.....	6.7
6.5 Hydraulic system Checking.....	6.9
6.6 Replacement of hydraulic hoses.....	6.11
6.7 Tightening torques for screw connections.....	6.12
6.8 Wheel maintenance.....	6.14
6.9 half axle maintenance.....	6.17
6.10 Drive transmission system maintenance.....	6.21
6.11 Operation of the cutting head.....	6.25
6.12 Smarowanie.....	6.28
6.13 Electrical system service and warning elements.....	6.33
6.14 Consumables.....	6.34
6.14.1 Hydraulic oil.....	6.34
6.14.2 Lubricants.....	6.35
6.15 Tires.....	6.36
6.16 Faults and how to remove them.....	6.37



PRONAR Sp. z o.o.

ul. Mickiewicza 101 A

17-210 Narew, Polska

tel./fax (+48 85) 681 63 29,

fax (+48 85) 681 63 83

<http://www.pronar.pl>; <https://pronar-recycling.com>

e-mail: pronar@pronar.pl; komunalny@pronar.pl



EC Declaration of Conformity

PRONAR Sp. z o.o. declares, with full responsibility, that the machine:

Machine description and identification data	
General description and purpose:	Tri-wing muchler
Type:	KPR 700
Model:	-
Serial number:	
Commercial name:	Tri-wing muchler PRONAR KPR700

referred to in this declaration meets the requirements of Directives:

- **2006/42/EC- MD** - Machine Directive,
- **2014/30/EU- EMC** - Electromagnetic Compatibility Directive,
- **2014/35/EU LVD** - Low Voltage Directive,
- **2016/1628 amended by 2020/1040** - Regulation of the European Parliament and of the Council (EU) of 14 September, 2016. on requirements for internal combustion engines.

The machine has been designed for and meets the requirements of the following standards:

**PN-EN ISO 12100; PN-EN ISO 4413; PN-EN ISO 14120; PN-EN ; PN-EN ISO 4254-1;
PN-EN ISO 4254-12 ; PN-EN ISO 13857;**

This declaration applies exclusively to the machine in the condition, in which it was sold and does not include components or parts added or subsequent modifications made by the final user.

The operator's manual is an integral part of the machine.

The Implementation Department Manager of PRONAR Sp. z o.o., 17-210 Narew, ul. Mickiewicza 101A is authorised to provide the technical documentation.

Narew, on 2023-01-20
Date and place issued

Z-CA DYREKTORA
d/s technicznych
członek zarządu
Roman Górczaniuk

PRONAR Sp. z o.o.
17-210 Narew, ul. Mickiewicza 101A
tel. 85 681 63-29, 682 72 54
Fax: 85 681 63 83
NIP 543-02-00-939, KRS 0000139188
BDO 000014169

Roman Górczaniuk
Full name of the authorised person, position,
signature

CHAPTER 1.

INTRODUCTION

PRONAR KPR700

1.1 DEAR USER

The manual instruction is intended for the end user. For this reason, some required maintenance is listed in the inspection tables but the procedure is not described in this publication. To perform them, call the manufacturer's authorized service center.

Before starting the machine, you will be familiarized with its construction, principle of operation, available equipment and operation, and above all safety rules. The operator and qualified personnel should be trained during final reception.

Remember!!! You can run the machine only when you have read the content of this "User Manual", you have been trained and you can handle it safely. In case of any doubts, contact the seller to clarify the problem.

The most important thing during operation is your safety, therefore, regardless of everything, all recommendations contained in the "User's Manual" should be observed and guided by reasonable procedure. Remember that the correct service, in accordance with the manufacturer's instructions, reduces the risk of an accident to a minimum, and working with the machine is more efficient and less emergency.

When buying machines, check the compatibility of serial numbers placed on the machine with the number entered in the "Warranty card" and in the sales documents. For information on identifying the machine, see "Basic information" chapter. We recommend that you have the most important serial numbers entered the field below.

Machine serial number:

--	--	--	--	--	--	--	--	--	--	--	--	--	--	--	--	--

WST.3.B-001.01.EN

1.2 RULES FOR USING THE USER'S MANUAL

The information contained in the publication is current as at the date of publication. As a result of improvement, some sizes and illustrations contained in this publication may not correspond to the actual state of the machine delivered to the user.

The drawings contained in this publication are aimed at clarifying the principle of machine operation and may differ from the facts. This can not be a reason for any claims for this. The manufacturer reserves the right to introduce constructional changes in the manufactured machines to facilitate operation and improve the quality of their work, without making any current changes to this publication.

The operating instruction is the basic equipment of the machine. If the information contained in this study prove not fully understandable to ask for aid to the point of sale in which the machine has been purchased or directly to the manufacturer.

The machine was constructed in accordance with applicable standards, documents and current legal regulations.

Separate studies can be attached to this manual that can be found in the chapter "*Attachments and additional materials*".

WST.3.B-002.01.EN

1.3 TARGET GROUP

The User Manual is intended for staff operating the machine called end users, and qualified persons (electrician, mechanic, plumber). Detailed information on the competences and liability of end users and qualified personnel can be found later in this chapter.

1.3.1 End user (User, Authorized User, Operator)

Who is the end user?

An end user, otherwise known as the user or operator, call the person authorized to operate the machine. The user can be authorized to handle the machine if the following conditions have been met.

- The user has familiarized with the content of the "User's Manual".
- He gets acquainted with the contents of the farm tractor instruction manual and observes its recommendations.
- He complies with road traffic regulations and transport regulations in force in the country in which the machine is used,
- He has been trained in terms of compliance with established maintenance and regulation plans.
- He has authorizations to drive vehicles (vehicle assemblies) required in the country of use.

Responsibilities and permissions

The user acquired by the user allows for safe handling of the machine. In unforeseen cases, the user should follow a reasonable procedure and take care of their safety, people located near a working machine and other traffic users.

The knowledge and skills are entitled to the end user to handle the machine, carry out maintenance and repair or adjustment procedures in the scope specified by the manufacturer. The activities that can be performed by the operator are marked with the pictogram:



1.3.2 Qualified person (qualified personnel)

Who is a qualified person?

We call a qualified person any person admitted to perform some maintenance, repair or regulatory work in the scope specified by the machine manufacturer and who gained appropriate technical education in a specific profession and confirmed by the relevant document, completed the training carried out by the authorized manufacturer's or seller staff, can see threats and counteract them. Professional experience and professional skills entitle a qualified person to carry out some repairs of the machine and perform basic maintenance procedures in the scope provided by the manufacturer. A qualified person in addition to the necessary knowledge has the skills to use the specialized accessories necessary to perform the obligations. The following persons include qualified persons:

- qualified mechanic,
- qualified electrician,
- qualified plumber.

Activities that can be performed by a qualified mechanic are marked with a pictogram:



Activities that can be performed by a qualified electrician are marked with a pictogram:



Activities that can be performed by a qualified plumber are marked with a pictogram:



1.3.3 Service personnel

Who is the service personnel?

Service personnel, otherwise known as the manufacturer's service or service, is a person or a group of qualified persons who have a much greater experience and knowledge to perform certain corrective and maintenance activities than qualified personnel. It has the right tools necessary to carry out work. The manufacturer's service has the required permissions and is a representative of a machine manufacturer or other equipment.

1.3.4 Unauthorized user

Who is an unauthorized user?

An unauthorized user also known as a bystander is a person who has not been trained by the manufacturer or an authorized seller, has not been familiarized with the basic issues of security, knowledge of the machine, did not familiarize with the entire content of the operating instructions, and therefore there are no authorizations to operate the machine. A bystander can not be admitted to work with the machine.

WST.3.C-002.01.EN

1.4 SYMBOLS AND TAGS USED IN THE MANUAL

1.4.1 Danger

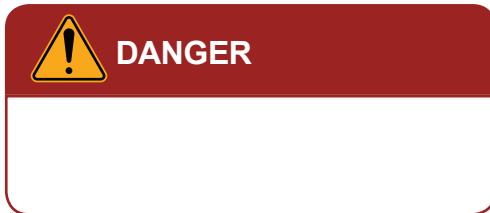

Information, descriptions of hazards and precautions as well as instructions and orders related to the safety of use in the content of the manual are marked with a frame with the word **DANGER**. Failure to comply with these recommendations may endanger the health or life of persons operating the machine or bystanders.

1.4.2 Caution

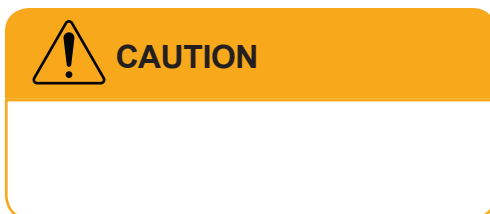









Particularly important information and recommendations, the observance of which is absolutely necessary, are highlighted in the text with a frame and word **CAUTION**. Failure to comply with these recommendations creates the risk of damage to the machine due to improper handling, adjustment or use.

1.4.3 Advice







Additional instructions contained in the manual describe useful information on operating the machine and are marked with a frame with the word **ADVICE**.

1.4.4 Personal protective equipment pictograms

	Work shoes
	reflective vest
	industrial helmet
	working clothes
	respiratory protection
	safety goggles
	protective gloves
	hearing protectors

1.4.5 Qualification pictograms

	operator
	qualified mechanic
	qualified plumber
	qualified electrician

1.4.6 Typography of the User Manual

Bulleted list

The bulleted list presents actions to perform whose order is not relevant.

Example of using a bulleted list

-
- Check the condition of connections and hydraulic and pneumatic hoses. Hydraulic oil leaks and air defects from a leaky installation are unacceptable.
- In the event of a hydraulic or pneumatic installation failure, the trailer should be turned off from operation until the failure is removed.
-

Comment on the text

Comment is most often a supplement and additional explanation to order a specific activity. Additional information can also be included in the comment.

An example of a comment

The required air pressure is described on the sticker placed on the machine frame, over the wheel.

Defined list

List shows the to-do, which execution order is important.

Example of using a defined list

1.
2. Unscrew the handles (2) securing the crank (1).
3. Insert the crank into a square shaft of the gear and turning the clock clockwise on the direction of the clock.
4.

References to pages

Reference to chapter (place in the manual) related thematically

An example of a reference application

 **page 9.4**

WST.3.B-004.02.EN

1.5 GLOSSARY

Agricultural tractor

A motor vehicle constructed for use together with agricultural, forest or gardening equipment; such tractor can also be adapted for pulling trailers and for earthworks.

Tractor

A car vehicle designed only to pull the trailer; This term includes a tractor and a ballast tractor.

Final acceptance

Group of activities associated with the preparation and actual transfer of the finished product for use. The final acceptance contains the transmission of documentation, basic training, reception for transport and the first launch of the machine.

Bystander

See - an unauthorized user

Qualified person

A person admitted to perform some maintenance, repair or regulatory work in the scope specified by the machine manufacturer and which has gained appropriate technical education in a specific profession and confirmed by the relevant document and completed the training carried out by the authorized manufacturer's or seller staff, can notice the threats and counteract them.

Truck

A car vehicle designed structurally for carriage; This term also includes a cargo-passenger car designed for transporting loads and people in a number from 4 to 9 including the driver.

Danger zone

A dangerous zone is an area around the machine in which people who are vulnerable to the risk of losing health or life.

TUZ

A three-point suspension system - a lever system used in agricultural tractors for aggregation of machines and devices suspended on a hydraulic lifter.

End user

Otherwise known as the user, an authorized user or operator, the person authorized to operate the machine.

Unauthorized user

Also known as a bystander - person who has not been trained and has not been allowed to handle the machine.

PTO

Power reception shaft - transmitting a drive from the vehicle to the moving machine.

WST.3.B-005.01.EN

1.6 DESIGNATION OF DIRECTIONS IN THE MANUAL

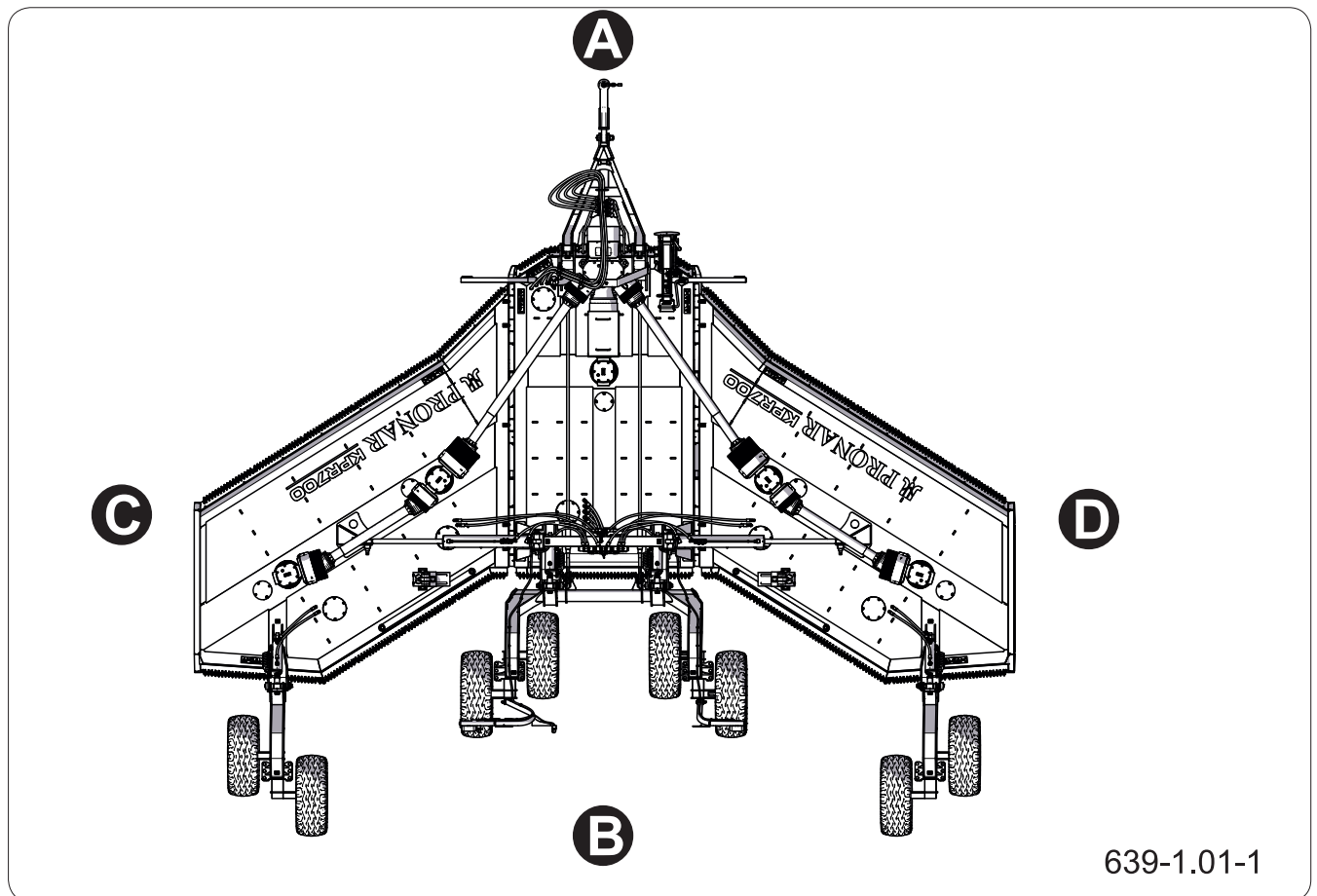

Figure 1.1 Determining directions on the machine
 (A) front (B) rear (C) left side
 (D) right side

Left side – the left hand side of the observer facing the machine in the forward direction.

Right side – the right hand side of the observer facing the machine in the forward direction.

Turn right – turn the mechanism clockwise (operator facing the mechanism).

Turn left – turn the mechanism counterclockwise (operator facing the mechanism).

WST.1.1-001.01.EN

1.7 FINAL ACCEPTANCE

1.7.1 Preliminary information

The final acceptance takes place after the machine has been delivered. The acceptance includes the following:

- Provide the required documents, including the "User's Manual", "Warranty Card" and others,
- information from the seller on how to use the machine, the dangers of not using the machine as intended, as well as on aggregating the machine with the tractor and working with it.
- inspection of the machine after delivery,
- checking the machine after delivery,
- first start-up of the machine and discuss machine operation.

1.7.2 Checking the machine after delivery

Scope of control

- Check the machine assembly according to your order.
- Check technical condition of guards,
- Check the condition of the paint coating, check for any signs of corrosion.
- Inspect the machine for damage resulting from improper transport of the machine to the destination (dents, punctures, bends or broken parts, etc.).
- Check the condition of the tires on the road wheels and the air pressure in the tires. Check the the correct tightening of the wheels.
- Check the condition of the flexible hoses of the hydraulic and pneumatic systems. Make sure that the systems are tight.
- Check hydraulic cylinders for leaks.

1.7.3 First start-up of the machine

Start-up must be preceded by training conducted by the Seller or authorized employees of the Seller.

The scope of the first start-up

- Ensure that the hydraulic and electrical connections on the agricultural tractor are in accordance with the manufacturer's requirements.
- Check all grease points, lubricate if necessary.

If the condition of the machine is OK, proceed to the test drive:

- Connect the machine to the appropriate tractor hitch.
- Connect the wires of the hydraulic and electrical systems.
- By activating individual lights, check the correct operation of the electrical system.
- Check the hydraulic system for correct operation by operating the tractor hydraulic distributor circuits.
- Start the PTO and check the operation of the driven system.
- Perform a test drive.

If during the test trip, disturbing symptoms such as:

- Noise and unnatural sounds from moving parts rubbing against the machine structure,
- Hydraulic oil leakage,
- Improper operation of hydraulic and/or pneumatic cylinders,

or other malfunctions, diagnose the problem. If the fault cannot be rectified or remedied, you will void the warranty, contact the place of purchase for clarification or repair.

After completing the test drive check the the tightness of the wheel nuts.

WST.1.1-002.01.EN

1.8 ENVIRONMENTAL HAZARD



DANGER

Used oil or collected residues mixed with absorbent material should be stored in an accurately marked container. Do not use food packaging for this purpose.



CAUTION

Oil waste may only be delivered to a point dealing with the utilization or regeneration of oils. Under no circumstances should oils be poured into drains or water bodies.

A leakage of hydraulic, lubricating or diesel oil is a direct threat to the natural environment due to the limited biodegradability of the substance.

When carrying out maintenance and repair works where there is a risk of leakage, perform these works in rooms with an oil-resistant surface. In the event of a substance leak into the environment, first secure the source of the leak, and then collect the spilled substance using available means. Collect the remaining oil with sorbents or mix with sand, sawdust or other absorbent materials. The collected contaminants should be stored in a sealed and marked container, resistant to hydrocarbons, and then transferred to a disposal point. The container should be kept away from heat sources, flammable materials and food.

Used oils or oils that cannot be reused due to the loss of their properties are recommended to be stored in their original packaging in the same conditions as described above.

WST.3.B-008.01.EN

1.9 PERSONAL PROTECTIVE EQUIPMENT

1.9.1 General



CAUTION

Personal protective equipment should be used in accordance with the recommendations of the security manufacturer.

Follow local regulations regarding personal protective equipment.

The personal protective equipment listed below is a minimum protection for the operator against the effects of unfavourable external factors and is only a recommendation for use.

We recommend carrying out a risk assessment at the machine's workplace and adjusting the personal protective equipment of operator depending on the actual working conditions.

1.9.2 Work clothing



Work clothing should fit the operator's body correctly. The material from which the clothing is made should be characterized by high tear strength. Clothing must not have any protruding elements that may be accidentally caught by the mechanisms of the machine.

1.9.3 Hearing protectors



It is recommended to use of ear muffs for use with a protective industrial helmet for hearing protection. The selection of the damping value should be selected individually depending on the noise level at the location of the machine, which is the result of various sources (e.g. tractor, loader, belt conveyors, etc.).

Remember to properly store and maintain your hearing protectors. Poorly stored and maintained hearing protectors lose their protective properties over time. Periodically replace the soundproofing cushions according to the manufacturer's recommendations.

1.9.4 Work shoes



Work shoes should have the following properties:

- non-slip sole,
- sole material made of a material resistant to oils, gasoline and other organic solvents.
- toe cap resistant to impact with an energy of 200 J,
- insert securing the foot against piercing of the sole.

The above properties correspond to the S3 shoe category according to PN-EN ISO 20345.

1.9.5 Warning vest



The warning (reflective) vest is designed to increase the operator's visibility to other users. Instead of a reflective vest, you may wear work clothes that meet the requirements of EN471. It is recommended that the warning vest (or work clothing) be class 2.

1.9.6 Protective gloves



Protective gloves should be selected depending on the currently performed work.

Strong protective gloves

Strong protective gloves for hand protection are used for protection during heavy work such as cleaning the machine, removing clogs and the like, where there is a risk of damaging the hands. Protective gloves should protect the hands from cuts, scratches, abrasions, punctures and similar injuries to the skin and

against light burns in contact with hot surfaces.

Light protective gloves

For light work (general operation, minor maintenance etc.), we recommend using light protective gloves for work in a dry or slightly oily environment. The working surface of the gloves (internal part should be covered with an impermeable material, e.g. nitrile).

Nitrile gloves

Nitrile gloves designed for working with urea, fuel or lubricants. They are designed for light work where there is a risk of skin contact with lubricants, fuel, urea, gear oil and hydraulic oil.

1.9.7 Safety glasses with side shields



Safety glasses to protect the eyes against contact with hazardous substances, splashing liquids or dust and airborne of the machine dust. Safety glasses with side shields increase the level of protection.

1.9.8 Industrial protective helmet



The industrial safety helmet is designed to protect the head against injuries related to the fall of thrown objects, parts or materials. The design of the helmet should be in accordance with the EN397 standard. During normal machine operation, wearing lightweight industrial helmets will not protect the user from injury and is therefore not recommended.

The protective helmet must fit correctly to the anatomical shape of the skull. There are adjustment straps for this purpose. The helmet has a limited shelf life.,

After this date, the material from which it was made loses its properties and does not fulfil the assumed task. The helmet must be replaced.

1.9.9 Anti-dust respirator



CAUTION

Remember that personal protective equipment should be regularly maintained and used in accordance with the recommendations of the product manufacturer. Following these guidelines will ensure safe use and the best protection.



Dust can become airborne when operating the machine. It is recommended to use disposable respirators with an exhalation valve to protect the respiratory tract.

The size of the mask should match the operator's face. The mask should fit snugly against the skin. The nasal part should be adjusted using the adjustment plate. Remember that facial hair can make it difficult to seal the face mask.

Minimum half mask recommendations:

- type FFP1, in accordance with EN-149: 2001 + A1: 2009, protection against non-toxic liquid or solid aerosols,
- P1 class.

WST.3.C-004.01.EN

CHAPTER 2

GENERAL

PRONAR KPR700

2.2 IDENTIFICATION

2.2.2 Machine identification

ADVICE

You should require the seller to carefully fill out the *Warranty "Card"* and complaint coupons. The lack of e.g. date of sale or point of sale stamp exposes the user to not accept any complaints.

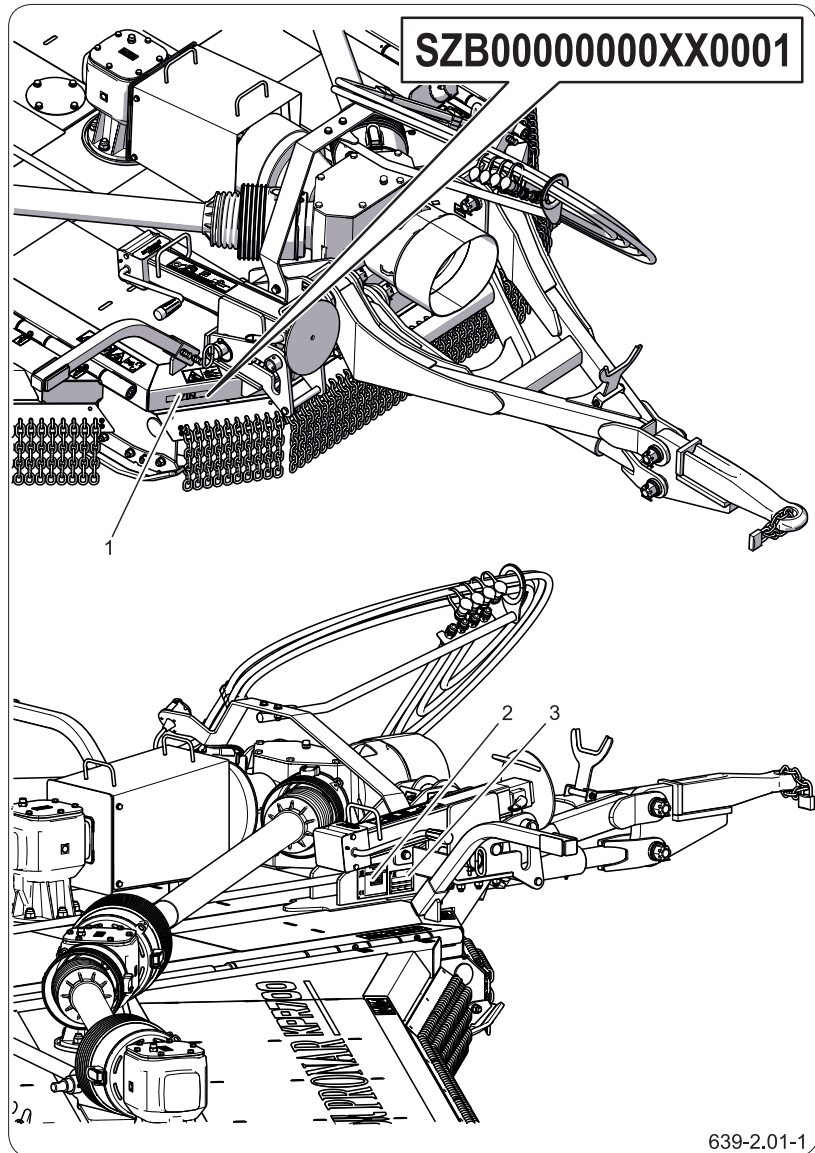

Figure 2.1 MACHINE IDENTIFICATION

- (1) VIN plate
- (2) nameplate PL
- (3) nameplate EU

The machine is marked with the identification plates (2) and (3) and the production number (1) located on the highlighted square on the machine frame. The machine has Polish and European homologation, therefore, due to the country of use and the regulations in force in it, the machine can be equipped with two models of data plates.

When purchasing the mower, check the compliance

of the serial numbers on the machine with the number written in the "Warranty Card", in the sales documents and in the "User's Manual".

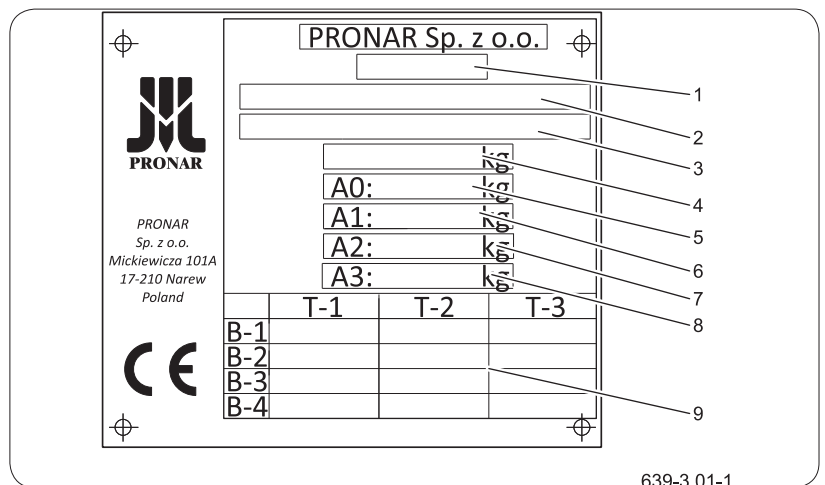

Figure 2.2 EU Nameplate

- 1 Category, subcategory and vehicle speed indicator
- 2 EU type-approval certificate number
- 3 VIN of the product
- 4 Permissible gross weight
- 5 Drawbar eye load
- 6 Maximum permissible mass on the axle 1
- 7 Maximum permissible mass on the axle 2
- 8 Maximum permissible mass on the axle 3
- 9 Technically permissible towable mass

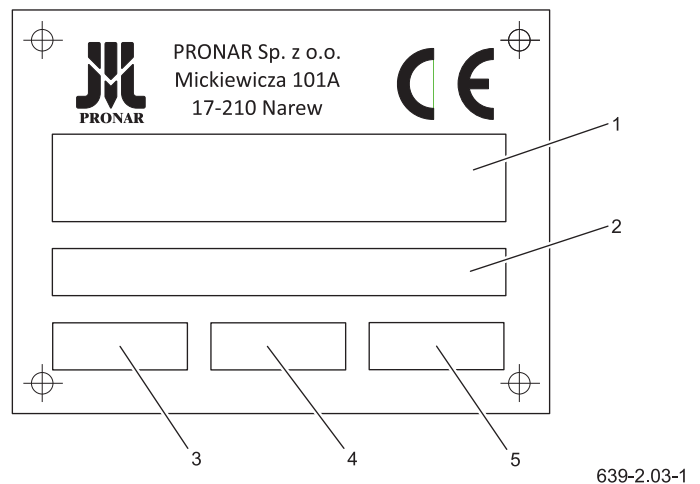

Figure 2.3 PL Nameplate

- 1 Trade name of the product or general term and function
- 2 VIN Number
- 3 Product type (granted in the EU approval process)
- 4 Product year
- 5 Product model

INF.1.1-001.01.EN

2.3 INTENDED USE OF THE MACHINE

2.3.2 Intended use



DANGER

The machine may not be used for purposes other than those for which it is intended.

The PRONAR KPR700 shredding mower is designed for large areas. The machine is used to:

- shredding of plant residues (stems) left in the fields after growing maize, tobacco, sunflower, etc.;
- mulching permanent grassland;
- mowing difficult grassland including bushes and thickets (branches up to 2 cm in diameter).

The mower cuts and at the same time grinds the material being cut, spreading it evenly over the entire area of the cut, allowing for a natural windrow, mineralization of plant residues and re-introduction into the soil.

When operating the machine, the road and transport regulations of the country must be observed and any violation of these regulations is treated by the manufacturer as misuse.

The PRONAR KPR700 mulching mower can be aggregated with a tractor that meets the requirements of the *Farm Tractor requirements* table.

Intended use also includes all activities related to the correct and safe operation and maintenance of the machine.

Therefore, the user is obliged to:

- get acquainted with the contents of the USER MANUAL and comply with its recommendations,
- understand the principle of machine operation and the safe and proper operation,
- work in compliance with general safety regulations,
- accident prevention,
- comply with traffic regulations.

The machine may only be used by persons who:

- are familiar with the content of this publication

and with the z content of the carrier's manual,

- have been trained in operation and work safety,
- have the required authorization to drive and are familiar with the traffic rules and transport regulations.

2.3.3 Expected inappropriate use

The PRONAR KPR700 shredding mower must not be used contrary to its intended use, in particular:

- transport people and animals,
- to carry any cargo,
- shredding materials other than plants and their residues,

An employee who has not been trained in operation and safety, is not qualified and has the required skills must not be allowed to operate the machine.

When operating the machine, it is strictly prohibited to:

- stay in the danger zone,
- climb on the machine while it is running,
- make arbitrary structural changes,
- repair and servicing by unauthorized and un-qualified personnel.

INF.1.1-002.01.EN

2.4 AGRICULTURAL TRACTOR REQUIREMENTS

Table 2.1. Agricultural tractor requirements

Content	Unit	Requirements
		PL
The hydraulic system		
Hydraulic oil	-	API: GL-4 (Agrol U) ⁽¹⁾
Maximum system pressure	bar/MPa	200 / 20
Oil demand	l	8
Hydraulic outputs required		sockets 12.5 ISO 7241-1 Type A 1 double-acting section and 1 double acting section with float position
Electrical system		
Electrical system voltage	V	12
Light socket	-	7 poles in accordance with ISO 1724
Tractor hitch required		
Type of hitch	-	lower, upper transport hitch
Minimum vertical load capacity of the hitch	kg	1300
Other requirements		
Min. tractor power	kW/KM	118/160 ⁽²⁾
Rear Power take-Off (PTO)	-	Typ 1 (1 3/8") wg ISO 500
Max rotational speed	rpm	1000

(1) – a different oil may be used, provided it can be mixed with oil in the machine. Detailed information can be found in the product information sheet in the appendix.

(2) – the power demand depends on the working conditions and properties of the shredded material

2.4.2 Minimum load on the front axle of the tractor



CAUTION

The front axle load of the tractor must be at least 20% of its curb mass and the aggregate load of the machine. If this condition is not met, add additional weight to the front axle.



DANGER

Improper ballast on the front axle of the tractor can cause damage, poor stability and the ability to steer and brake the tractor.

The front axle of the agricultural tractor must always be loaded with at least 20% of the unladen weight of the tractor and the aggregate load of the machine. See chapter „Terms of use”

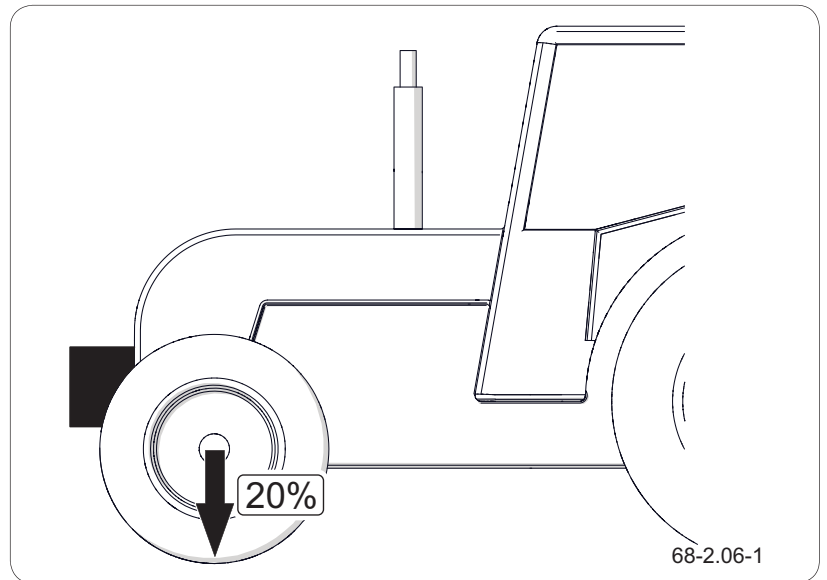

Figure 2.4 Minimum load on the front axle of the tractor

INF.1.1-003.01.EN

2.5 EQUIPMENT OF THE MACHINE

Table 2.2. Equipment

Content	STANDARD	ADDITIONAL	OPTIONAL
User manual	•		
Warranty Card	•		
Electrical installation connection cable	•		
Electrical lighting installation	•		
Wheel chocks	•		
Rotary tie rod Ø50			•
Ball tie rod K80			•
Ø40 fixed tie rod	•		
Lower drawbar	•		
Upper drawbar			•
PTO shafts for connecting the machine with a tractor	•		
Counter knives (passive knives)			•
Six-knife heads			•

PTO shaft recommended **B&P CS8R111CEWS70A5AX**

(1) Some of the standard equipment listed in the table may not be included with your machine. This is due to the possibility of ordering a new machine with a different set - optional equipment, replacing the standard equipment. The tire information is given at the end of the publication in APPENDIX.

INF.1.1-004.01.EN

2.6 TRANSPORT

The machine is ready for sale completely assembled and does not require packing. Only the machine's technical documentation and any additional equipment elements are packed. Delivery to the user is carried out by road or independent transport (towing of the machine with a carrier).

2.6.2 Trucking

Load and unload the machine from the car using the loading ramp with a farm tractor. During work act in compliance with the general principles of workplace health and safety for reloading work. Persons operating reloading equipment must have the required permissions to use these devices. The machine must be correctly connected to the tractor in accordance with the requirements contained in this manual.

The machine should be attached firmly to the platform of the vehicle using straps, chains, lashings or other

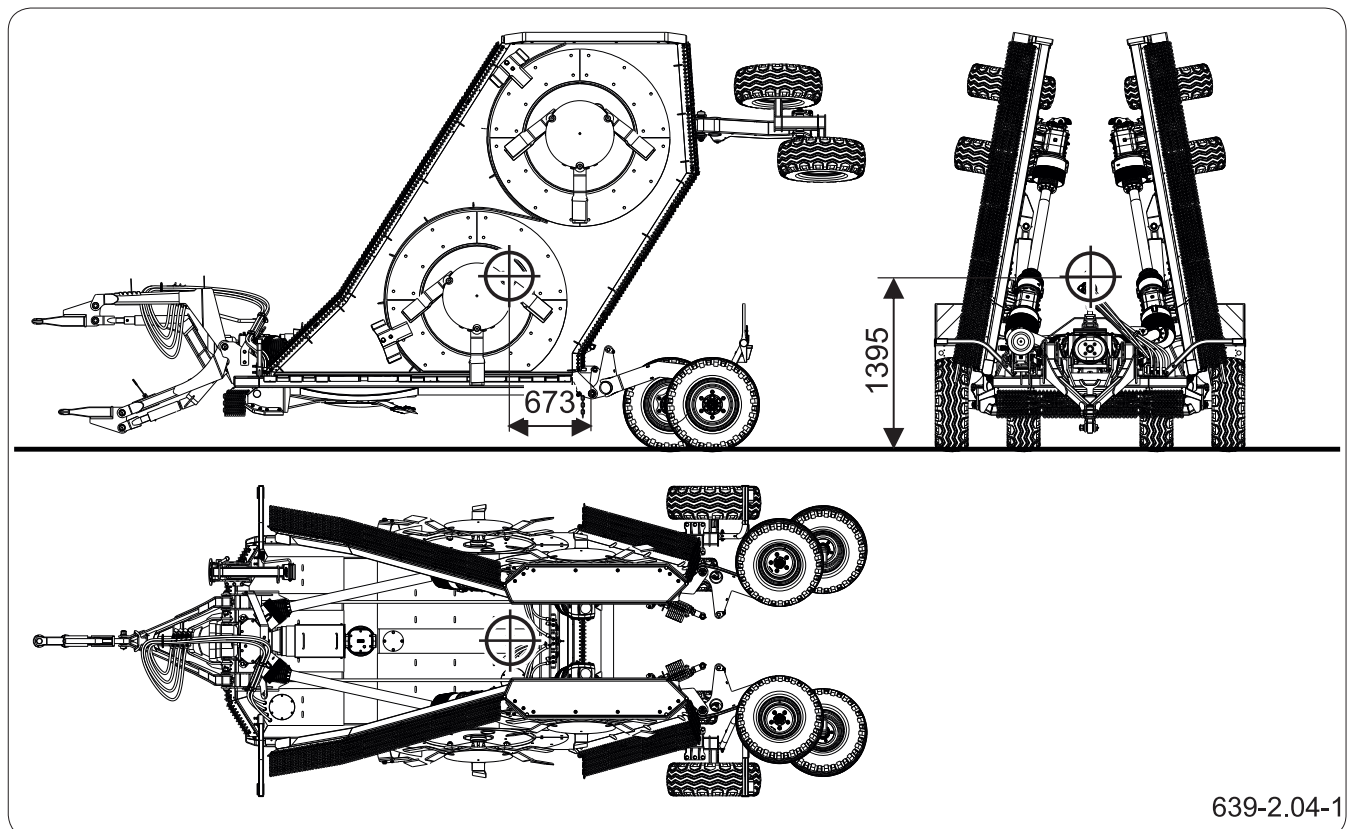

639-2.04-1

Figure 2.5 Location of the centre of gravity of machine

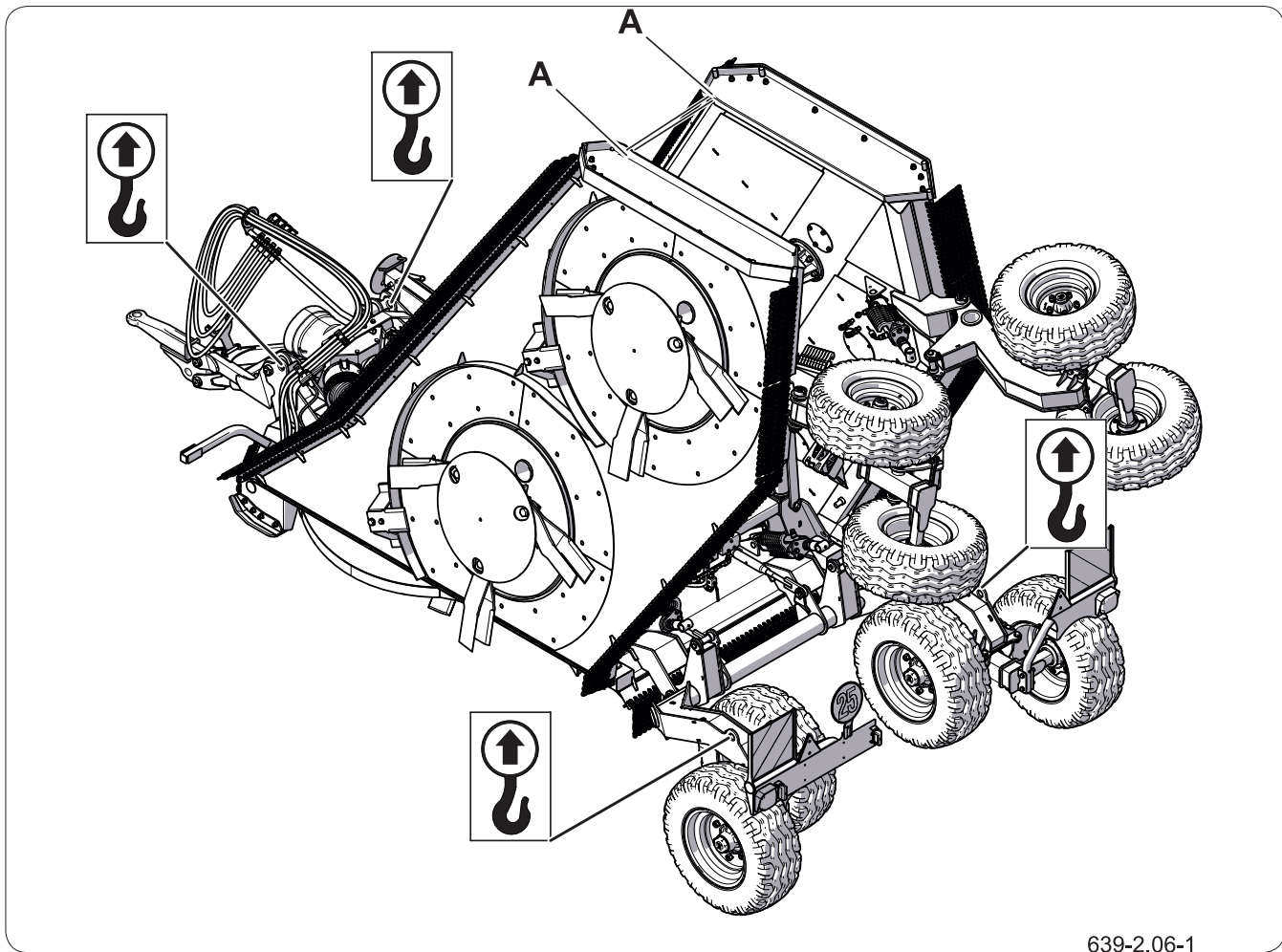

639-2.06-1

Figure 2.6 Attachment points
 (A) arms fastening point - *DO NOT* attach slings and straps.



CAUTION

It is forbidden to attach slings and all kinds of fastening elements to the elements of the hydraulic and electrical systems as well as the slender elements of the machine (e.g. covers, wires).



CAUTION

During transport, fasten the arms in the place indicated in this study.

fastening devices equipped with a tensioning mechanism. Secure the fasteners in the shipping brackets (1) for this purpose.

Chocks or other elements without sharp edges should be placed under the machines wheels, protecting the machine against rolling. The wheel lock must be secured to the vehicle loading platform in such a way that it cannot move.

Use approved and technically reliable securing measures. Wiping belts, cracked fasteners, bent or corroded hooks or other damage may disqualify the product from being used. Please refer to the instructions in the manual of the manufacturer of the securing material used. The number of fastening elements (ropes, belts, chains, lashings, etc.) and the force

**DANGER**

During road transport, the machine must be mounted on the platform of the vehicle in accordance with safety requirements and regulations.

While driving, the car driver should exercise extreme caution. This is due to the vehicle's centre of gravity shifting upwards with the machine loaded.

Use only approved and technically reliable securing measures. Read the operating instructions of the securing measures manufacturer.

Incorrect use of securing measures can cause an accident.

needed for their tension depends, among others, on the weight of the trailer, the construction of the car carrying the trailer, the speed of travel and other conditions. Therefore, it is not possible to specify the fastening plan in detail.

For optimum attachment of the machine to the load platform, support the drawbar by placing a wooden block under the drawbar. A properly attached machine will not change its position relative to the transporting vehicle. The fastening means must be selected according to the manufacturer's instructions. In case of doubt, a larger number of attachment and securing points for the machine be used. If necessary, the sharp edges of the machine must be secured to protect the fastening means against damage during transport.

During reloading work, particular attention be paid so as not to damage the machine equipment components and the paint coating.

**CAUTION**

When transporting independently, the operator should read the instructions the operating and follow the recommendations contained therein.

If you decide to transport the machine after purchasing, read and follow the machine's User's Manual. Independent transport involves towing a wrapper with own agricultural tractor to its destination. While driving, adjust the speed to the prevailing road conditions, but it must not be greater than the maximum design speed.

INF.1.1-005.01.EN

2.7 TERMS & CONDITIONS OF WARRANTY

TIP

Demand that the seller carefully and accurately fills out the Warranty Book and warranty repair coupons. A missing date of purchase or sale point stamp may make the user ineligible for any warranty repair or refund.

PRONAR Sp. z o.o. Narew guarantees the reliable operation of the machine when it is used according to its intended purpose as described in the *Operator's Manual*. Defects discovered during the warranty period will be removed by the Warranty Service. The repair period is specified in the *Warranty Book*.

The warranty does not cover those parts and sub-assemblies of the machine which are subject to wear in normal usage conditions, regardless of the warranty period.

The warranty service only applies to such cases as: mechanical damage which is not the user's fault, factory defects of parts, etc.

In the event of damage arising from:

- mechanical damage which is the user's fault, damage caused by road accidents,
- inappropriate use, adjustment or maintenance, use of the machine for purposes other than those for which it is intended,
- use of damaged machine,
- repairs carried out by unauthorised persons, repairs carried out improperly,
- making unauthorised alterations to machine design,

the user will lose the right to warranty service.

The user is obliged to immediately report all noticed damage, regardless of whether the damage is covered by the warranty or not. For detailed Terms & Conditions of Warranty, please refer to the *Warranty Book* attached to each newly purchased machine.

Modifications of the machine without the written consent of the Manufacturer are prohibited. In particular, do NOT weld, drill holes in, cut or heat the

main structural elements of the machine, which have a direct impact on the machine operation safety.

s. salgsdatoen eller stempelet på salgsstedet udsætter brugeren for ikke at acceptere nogen klager.

INF.1.1-006.01.EN

2.8 ENVIRONMENTAL RISK



DANGER

Used hydraulic oil or gathered remains mixed with absorbent material should be stored in a precisely marked container. Do not use food packaging for this purpose.



IMPORTANT

Waste oil should only be taken to the appropriate facility dealing with the re-use of this type of waste. Do NOT dispose of or pour oil into sewerage drains or water reservoirs. .

TIP

The hydraulic system of the mower is filled with Agrol U Lotos hydraulic oil.

A hydraulic oil leak constitutes a direct threat to the natural environment owing to its limited biodegradability. While carrying out maintenance and repair work, which involves the risk of an oil leak, this work should take place on an oil resistant floor or surface. In the event of oil leaking into the environment, first of all contain the source of the leak, and then collect the leaked oil using available means. Remaining oil should be collected using sorbents, or by mixing the oil with sand, sawdust or other absorbent materials. The oil contaminations, once gathered up, should be kept in a sealed, marked, hydrocarbon resistant container, and then passed on to the appropriate oil waste recycling centre. The container should be kept away from heat sources, flammable materials and food.

Oil which has been used up or is unsuitable for further use owing to loss of its properties should be stored in its original packaging in the conditions described above.

INF.1.1-007.01.EN

2.9 WITHDRAWAL FROM USE



DANGER

Reduce the residual pressure in the hydraulic system before dismantling.



DANGER

During dismantling, use appropriate tools and equipment (overhead cranes, elevators, lifts, etc.) and use personal protective equipment, i.e. protective clothing, footwear, gloves, glasses, etc.

Avoid oil contact with skin. Do not allow oil to leak.

If the user decides to withdraw the machine from use, follow the disposal and recycling regulations of the end-of-life machines in your country.

Reduce the residual pressure in the hydraulic system before dismantling, completely remove the oil.

In the event of parts being replaced, worn or damaged sent them to a recycling centre. Used oil as well as rubber or plastic elements send to plants dealing with the utilization of this type of waste.

Table 2.3. The codes for the waste arising from disassembly machines

Item	Code	Meaning
1	07 02 13	Plastic waste
2	13 01 10	Other hydraulic oils
3	13 02 04*	Mineral engine, transmission and lubricating oils containing organochlorines
4	13 02 06*	Synthetic engine, transmission and lubricating oils
5	13 02 08*	Other engine, transmission and lubricating oils
6	13 05 02*	Sludges from oil drainage in separators
7	13 05 08*	A mixture of wastes from sandblasting and oil drainage in separators
8	15 01 10*	Packaging containing or contaminated with residues of dangerous substances
9	15 02 02*	Sorbents, filter materials and protective clothing contaminated with hazardous substances
10	16 01 03	Worn tires
11	16 01 17	Ferrous metals
12	16 01 22	Other items not listed

INF.1.1-008.01.EN

SAFETY OF USE

PRONAR KPR700

3.1 SAFE USE



IMPORTANT

If the information in this Operator's Manual is difficult to understand, contact the seller who runs the authorised technical service on behalf of the Manufacturer, or contact the Manufacturer directly.

- Before using the machine, carefully read this Operator's Manual, the Operator's Manual of the PTO shaft and Terms & Conditions of Warranty. When operating the machine, the operator must follow all instructions and recommendations in these documents.
- The machine may only be used by persons qualified to drive carrier vehicles (tractors) and trained in machine operation. Mulching mower can be operated by a single person only.
- Careless and incorrect use of the machine and failure to follow instructions of this Operator's Manual poses danger to the operator and bystanders.
- Be aware of the residual risk. Use caution when operating this machine and follow all relevant safety instructions.
- The machine must never be used by persons, who are not authorised to drive carrier vehicles (agricultural tractors), including children and people under the influence of alcohol or other drugs.
- The machine must not be used for purposes other than those for which it is intended. Anyone who uses the machine for purposes other than those for which it is intended takes full responsibility for any consequences of this potentially incorrect use. Use of the machine for purposes other than those for which it is intended by the Manufacturer may invalidate the guarantee.

- The machine may only be used when all the protective features (i.e. safety guards, bolts, cotter pins, warning decals) are technically sound and correctly positioned. In the event of loss or damage to the protective features, they must be replaced with new ones.

BHP.1.1-001.01.EN

3.2 SAFETY WHEN HITCHING THE MACHINE

- The machine should be hitched to and transported with only such a tractor which meets all the manufacturer's requirements (minimum tractor power demand, required tractor hitch etc.) – see table *Agricultural tractor requirements*.
- Do NOT hitch the machine to carrier vehicle (agricultural tractor) if hydraulic oil in the two machines is of different types.
- After completion of hitching the machine, check the safeguards.
- Use only genuine pins and safeguards to hitch the machine to the carrier vehicle.
- The carrier vehicle (agricultural tractor) to which the machine will be coupled must be technically reliable and must meet all manufacturer's requirements.
- Be especially careful when hitching and unhitching the machine.
- When hitching, there must be nobody between the machine and the carrier vehicle.
- Coupling and uncoupling may only take place with the machine and carrier vehicle (agricultural tractor) switched off.
- Machine unhitched from the carrier vehicle must be placed on level, sufficiently hard surface in such a manner as to ensure that it is possible to connect it again.

BHP.1.1-002.01.EN

3.3 SAFETY RULES WHEN MAINTAINING HYDRAULIC SYSTEM

- The hydraulic system is under high pressure when operating.
- Regularly check the technical condition of the connections and the hydraulic conduits. There must be no oil leaks.
- In the event of the hydraulic system malfunction, discontinue using the machine until the malfunction is corrected.
- When connecting hydraulic lines to carrier vehicle, make sure that the hydraulic system is not under pressure. If necessary, reduce residual pressure in the system.
- In the event of injuries being caused by pressurised hydraulic oil, contact a doctor immediately. Hydraulic oil may find its way under the skin and cause infections. In the event of contact of oil with eye, rinse with large quantity of water and in the event of the occurrence of irritation consult a doctor. In the event of contact of oil with skin wash the area of contact with water and soap. Do NOT apply organic solvents (petrol, kerosene).
- Do not store hydraulic oil in packaging designed for storing food or foodstuffs.
- Rubber hydraulic conduits must be replaced every 4 years regardless of their technical condition.
- Repair and replacement of hydraulic system elements should be entrusted to the appropriately qualified persons. passende kvalificerede personer.

BHP.1.1-003.01.EN

3.4 SAFETY DURING TRANSPORTATION



DANGER

Always disconnect the shaft from the tractor during transport.

Accidental operation of the machine with the arms raised may result in loss of health or life of the bystanders.



CAUTION

Operating the machine with the arms raised may damage the relay shafts

Before driving, you must:

1. Make sure that the machine is properly connected to the tractor.
2. Fold the mower wings into the transport position, secure the mower wings with the lock.
3. Raise the suspension to the correct height using the hydraulic system, secure the cylinder (Figure *Transport locks*).
4. At the rear of the machine, a triangular sign identifying slow moving vehicles must be placed in the plate holder .
5. Check the lighting operation.

And beyond this:

- When driving on public roads, comply with the road traffic regulations in force in the country where the machine is used.
- Do not exceed the speed limit resulting from road conditions and construction restrictions (maximum 40 km/h). Adjust speed to road prevailing conditions.
- Do not transport persons on the machine or transport materials.
- Before using the machine always check its technical condition, especially in terms of safety. In particular, check the technical condition of the suspension system and the connecting elements of the hydraulic system.
- Reckless driving and excessive speed can cause an accident.
- Use extreme caution when driving the machine on uneven terrain and reduce ground speed due to the possibility of damage and/or tipping of the media with the machine.

BHP.1.1-004.01.EN

3.5 MAINTENANCE AND CLEANING

- During the warranty period, any repairs may only be carried out by warranty service authorised by the Manufacturer. It is recommended that necessary repairs to machine should be undertaken by specialised workshops.
- In the event of any fault or damage, do not use the machine until the fault has been corrected.
- During work, use the proper, close-fitting protective clothing, gloves and appropriate tools. When working on hydraulic systems it is recommended to use oil resistant gloves and protective goggles.
- Any modification to the machine frees the manufacturer from any responsibility for damage or detriment to health which may arise as a result.
- Before undertaking any work on the machine, switch off the carrying vehicle engine and wait until all rotating parts come to a stop.
- Regularly check the technical condition of the safety devices and correct tightening of bolt connections.
- Regularly perform service inspections of machine as recommended by the Manufacturer.
- Do NOT perform maintenance or repair work under raised and unsupported machine.
- Before beginning repairs on hydraulic systems, reduce oil pressure.
- Servicing and repair work should be carried out in line with the general principles of workplace health and safety. In the event of injury, the wound must be immediately cleaned and disinfected. In the event of more serious injuries, seek a doctor's advice.
- Repair, maintenance and cleaning work should be carried out with the carrier vehicle (agricultural

tractor) engine turned off and the ignition key removed. Immobilise the carrier vehicle (agricultural tractor) with parking brake. Ensure that unauthorised persons do not have access to the carrier vehicle (agricultural tractor) cab.

- Should it be necessary to change individual parts, use only original parts. Non-adherence to these requirements may put the user and other people's health and life at risk, and also damage the machine and invalidate the warranty.
- Regularly check technical condition and mounting of all guards and protective elements.
- In the event of work requiring the machine to be raised, use properly certified hydraulic or mechanical lifts for this purpose. After lifting the machine, stable and durable supports must also be used.
- The machine must not be supported using fragile elements (bricks or concrete blocks).
- After completing work associated with lubrication, remove excess oil or grease.
- In order to reduce the danger of fire the machine must be kept in a clean condition.
- The machine should be cleaned as needed.
- Before using the pressure washer the user is obliged to acquaint himself with the operating principles and recommendations concerning safe use of this equipment.
- Before washing, remove manually and as accurately as possible any remaining mulched plant residue.
- Use only clean running water. Cleaning detergents with neutral pH may be used, which do not react aggressively with the mobile stockpiler's structural elements.
- The use of a pressure washer increases washing effectiveness but care must be taken

**DANGER**

Carefully read the instructions for application of detergents and maintenance preparations.

While washing with detergents, wear appropriate protective clothing and goggles protecting against splashing.

during work. During washing, the washer nozzle may not be placed closer than 50 cm from the cleaned surface.

- Water temperature should not exceed 55°C.
- Do not aim the water jet directly at system components and equipment, i.e. control valves, bearings, electric and hydraulic plugs, lights, electrical connectors, information and warning decals, nameplate, cable connectors, lubrication points, control panels, safety switches etc. High pressure water jet may penetrate the machine, resulting in mechanical damage or corrosion.
- Do not apply organic solvents, preparations of unknown origin or other substances, which may cause damage to lacquered, rubber or plastic surfaces. In the event of doubt it is recommended to make a test on an unseen surface area.
- Washing detergent should be kept in original containers, optionally in replacement containers, but very clearly marked. Preparations may not be stored in food and drink containers or in unmarked containers.
- Observe the environmental protection rules, wash the machine in places designed for this purpose.

BHP.1.1-005.01.EN

3.6 SAFETY DURING MACHINE OPERATION



DANGER

The machine can throw objects at considerable distances during operation. The affected danger zone is about 100 m.

Stop the machine when bystanders are in the affected danger zone.

- Before starting the mower make sure that there are no bystanders (especially children) or animals in the danger zone.
- The machine operator is obliged to ensure proper visibility of the machine and the working area.
- Do not enter the machine rotation and folding zone.
- Before starting the machine, always ensure that all the safety guards are in good condition and in place. Damaged or incomplete sub-assemblies must be exchanged for original new ones.
- During mowing use the correct working position.
- Before raising and lowering the machine's wings, make sure there are no bystanders nearby.
- Before starting the tractor with the connected machine make sure the PTO drive is not engaged, otherwise it can lead to uncontrolled operation of the machine.
- During machine operation do not occupy a different position than that of the operator in the tractor's cab. Do NOT leave the cab, when the machine is in operation.
- Do NOT stand within the material spreading zone or between the machine and the carrier vehicle.
- Do NOT approach the machine until the rotating parts come to a complete stop.

BHP.1.1-006.01.EN

3.7 SAFE OPERATION OF THE PTO SHAFT



DANGER

Before disconnecting the shaft, you must:

- disengage PTO drive
- switch off the engine of the implement carrier (tractor)
- remove key from ignition

- The machine may only be connected to the carrier vehicle (tractor) by means of an appropriately selected PTO shaft recommended by the Manufacturer.
- Before using the machine, carefully read the PTO shaft Operator's Manual and follow all instructions.
- Adjust the length of PTO shaft to compatible carrier vehicle (tractor) according to the Operator's Manual of PTO shaft.
- The PTO shaft has markings on the casing, indicating which end of the shaft shall be connected to the carrier vehicle (tractor).
- Never use a damaged PTO shaft, it may cause an accident. A damaged shaft must be repaired or replaced.
- Disconnect the shaft drive each time when it is not necessary to drive the machine, or when the carrier vehicle (tractor) and the machine are positioned at an unsuitable angle with regard to each other.
- The chains preventing the shaft cover from turning while the shaft is working, shall be secured to a fixed element of machine structure.
- Do NOT use the securing chains to support the shaft while machine is parked or when transporting the machine.
- The drive shaft must be equipped with a cover. Do NOT use the shaft with damaged or missing guards.
- After connecting the shaft, ensure that it is correctly and safely connected to the carrier vehicle (tractor) and to the machine.
- Before connecting PTO shaft, make certain that the PTO rotation direction is correct.

- Do NOT wear loose clothing, straps or whatever that may become wrapped round the rotating drive shaft. Contact with rotating PTO shaft may cause severe injuries.
- Do NOT go over and under the shaft or stand on it equally during work as also when the machine is parked.

BHP.1.1-007.01.EN

3.8 RESIDUAL RISK

Pronar Sp. z o. o. in Narew has made every effort to eliminate the risk of accidents. There is, however, a certain residual risk, which could lead to an accident, and this is connected mainly with the actions described below:

- using the machine for purposes other than those for which it is intended,
- being between the carrier vehicle (agricultural tractor) and the machine while the engine is running and when the machine is being attached,
- being on the machine while the engine is running,
- operating the machine with removed or faulty safety guards,
- not maintaining a safe distance from the danger zone or being within the zones while the machine is operating,
- machine operation by unauthorized persons or persons under the influence of alcohol or psychoactive substances
- cleaning, maintenance and technical checks when carrier vehicle (agricultural tractor) is connected and engine is running.

The residual risk may be kept to a minimum by following the recommendations below:

- operate the machine in prudent and unhurried manner,
- sensibly apply the remarks and recommendations contained in the Operator's Manual,
- carry out repair and maintenance work in line with operating safety rules,
- repair and maintenance work should be carried out by persons trained to do so,
- use close fitting protective clothing,
- ensure unauthorised persons have no access to the machine, especially children,



- maintain a safe distance from prohibited or dangerous places
- do not climb on the machine when it is operating or transported







BHP.1.1-008.01.EN

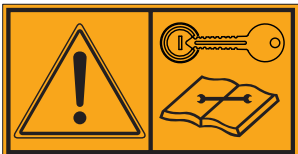

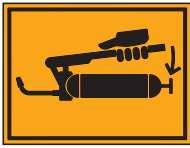

3.9 INFORMATION AND WARNING STICKERS

The machine is marked with information and warning decals mentioned in table. The machine user is obliged to ensure that the inscriptions, warning and information symbols placed on the machine are legible throughout the entire period of use. In the event of their destruction, they must be replaced. New assemblies replaced during repair must be marked again with the appropriate safety signs. When cleaning the machine, do not use solvents that may damage the label coating and do not direct a strong water jet.

Table 3.1. Information and warning stickers

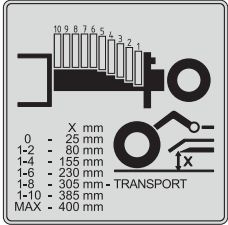
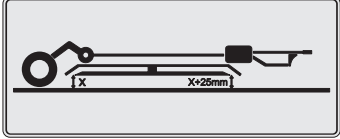
Item	Sticker	Meaning
1		<p>Thrown or flying objects, endanger the whole body. Keep a safe distance. 178N-0000006</p>
2		<p>Location of belts or chains 178N-0000009</p>
3		<p>Before starting the use read the operating instructions. 185N-0000001</p>
4		<p>Before starting any servicing or repair work, switch off the tractor engine and remove the ignition key. 185N-0000002</p>

Item	Sticker	Meaning
5		<p>Entire body pull-in - Transmission System 185N-00000003</p>
6		<p>Crushing of the whole body - force applied from above Crushing - mower arm 185N-00000007</p>
7		<p>Cuts to fingers or hands. Do not touch machine components before all machine assemblies have stopped. 185N-00000010</p>
8		<p>Lubricate the machine according schedule outlined in the User's Manual. 185N-00000011</p>
9		<p>Do not exceed the maximum PTO speed 188N-00000002</p>
10		<p>Do not open or remove the safety guard while the engine is running. Cutting fingers or toes - Rotor mower knife. 586N-05000002</p>
11		<p>Crushing of the whole body - force applied from above Secure the lift cylinder with a locking device before entering the danger zone 586N-05000003</p>

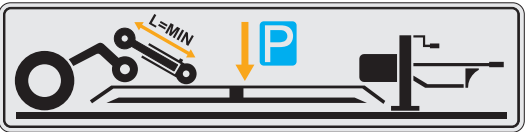
Item	Sticker	Meaning
12		<p>High pressure liquid stream. Keep a safe distance. 586N-05000004</p>
13		<p>Cutting height 639N-04000003</p>
14		<p>Positioning of the mower 586N-05000006</p>
15		<p>Type of machine 639N-04000001</p>
16		<p>Type of machine 639N-04000002</p>
17		<p>Beware of falling knife. 586N-05000011</p>
18		<p>Support point 443N-00000007</p>
19		<p>Support foot 586N-05000008</p>

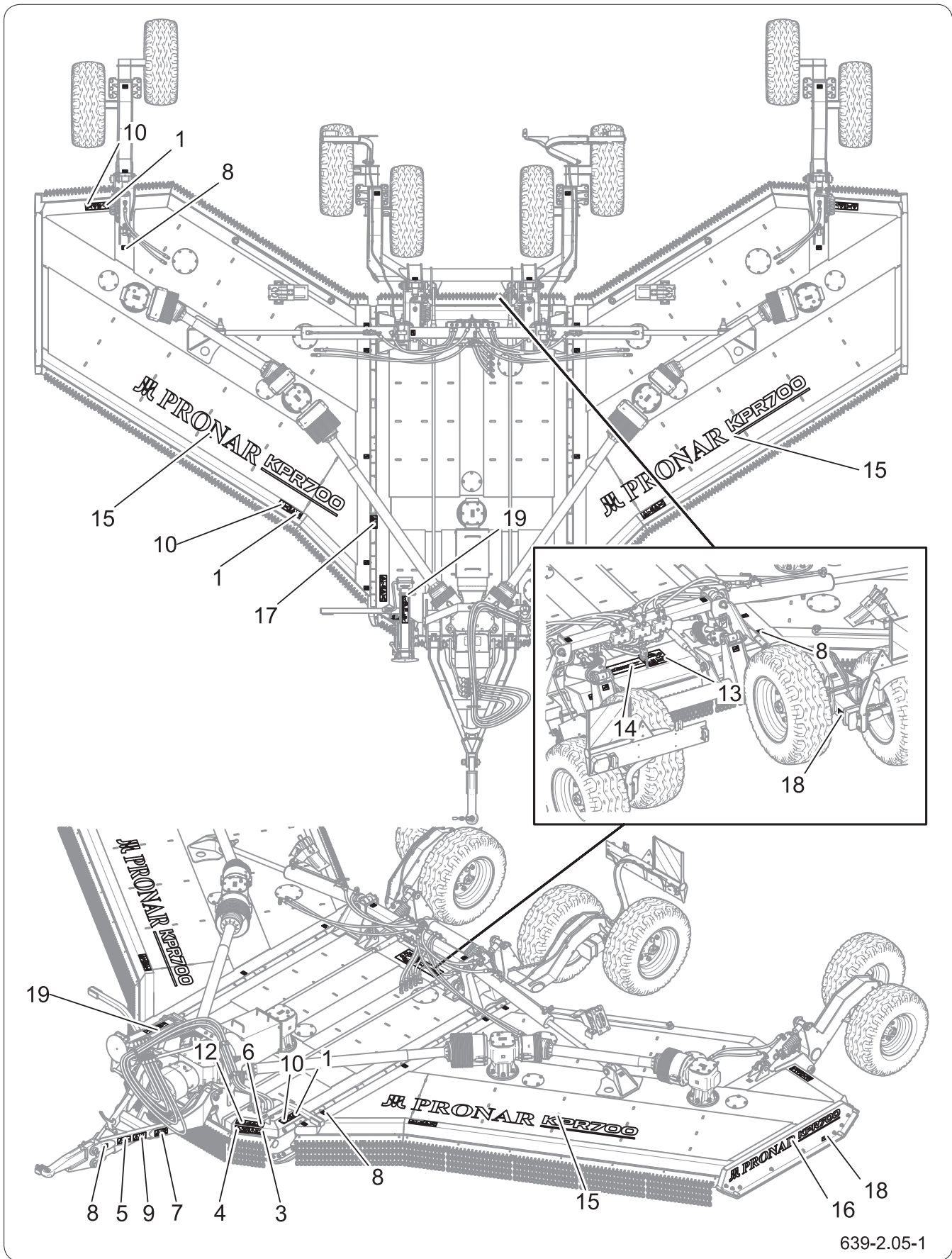

Figure 3.8 Arrangement of information and warning stickers

CONSTRUCTION AND PRINCIPLE OF OPERATION

PRONAR KPR700

4.1 TECHNICAL CHARACTERISTICS

Content	Unit	KPR700
Dimensions		
Width in working position	mm	7200
Width in transport position	mm	Below 3000 (depending on mower setting)
Height in transport position	mm	Below 4000 (depending on mower setting)
Length in transport position	mm	6465 (depending on mower setting)
Performance parameters		
Cutting width	mm	7000
Overlap of mowing areas	mm	140/105
Permissible gross weight	kg	4300***
Loading of the drawbar hitch	kg	1300
Min. power	kW/KM	118/160
Hitch	-	Field hitch or top hitch Ø40, Ø50 rotary, K80
Number of cutting heads	pcs.	5
Number of knives on cutterhead	pcs.	3 or 3x2
Cutting height	mm	25- 400
Copying the terrain	de-grees	15° down, 30° up
Transport position		Towed on a hitch, folded arms secured with lock, suspension system raised to transport position.
Suspension system	-	The rear of the mower is mounted on the wheels, the front is supported by the tractor hitch.
PTO maximum speed	-	1000
Speed of operation	km/h	(5-20)*
Permissible design speed**	km/h	40
Nominal pressure in hydraulic system	MPa (bar)	18 (180)

Content	Unit	KPR700
Sound pressure level	dB	– (at nominal PTO speed 1000 rpm)
Tires	-	10.0/75-15.3 122A8 – 400 kPa 10.0/80-12 122A8 – 400 kPa

**) - the speed of work to adapt to the type and amount of chipped material and terrain*

****) - the permissible transport speed is determined by local traffic regulations in the country of the machine user*

****) - depending on optional equipment*



CAUTION

Depending on the additional equipment of the machine, some technical parameters may change.

BIZ.1.1-001.01.EN

4.2 CONSTRUCTION GENERAL AND PRINCIPLE OF OPERATION

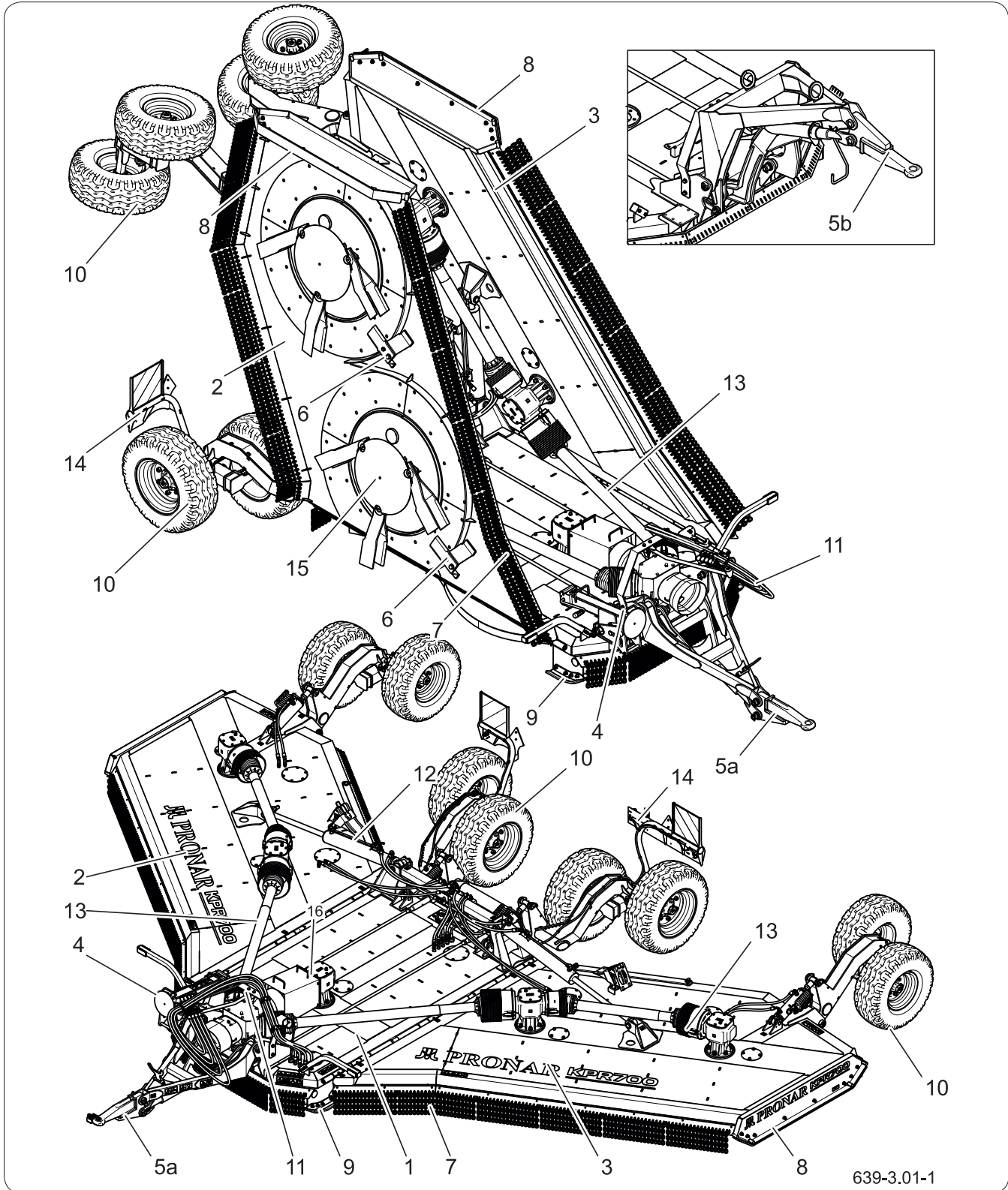

Figure 4.1 Construction of the machine

- | | | |
|--------------------------------------|------------------------|-----------------------|
| (1) centre plate | (2) right arm | (3) left arm |
| (4) support foot | (5a) lower drawbar | (5b) upper drawbar |
| (6) fixed knives
(counter knives) | (7) chain guard | (8) arm skid |
| (9) centre plate skid | (10) suspension system | (11) hydraulic system |
| (12) arm actuator | (13) transmission | (14) rear lighting |
| (15) cutterhead | | |

639-3.01-1

The KPR700 mulching mower is a trailed machine that can only be aggregated with a carrier (agricultural tractor) equipped with a lower or upper transport hook. Aggregation is carried out by means of a lower (5A) or upper (5B) drawbar.

The main components of the mower are the center plate (1) with suspension (10) and cutterhead (15) and folding arms (2), (3) with cutting heads (15). The mower wings are folded into the transport position by means of hydraulic cylinders (12).

The cutting heads (15) are driven by the power train (13) consisting of angle gears, IDL shafts and split gear.

At the rear of the mower is the axle assembly (10). The axle assembly consists of a axle frame, adjustment tie rods and wheel axle shafts. The height of the mower suspension on the ground can be adjusted hydraulically by means of a cylinder and a linkage system connected to the drawbar.

When the machine is lowered to the maximum, the mower will rest on the skids located under the front of the centre plate (9) and on the edges of the arms (8) Chain guards (7) are used to protect against ejection from under the cutting knives.

The machine is equipped with rear lighting (14) (position lights, stop lights, turn signals).

BIZ.1.1-002.01.EN

4.3 SUSPENSION SYSTEM

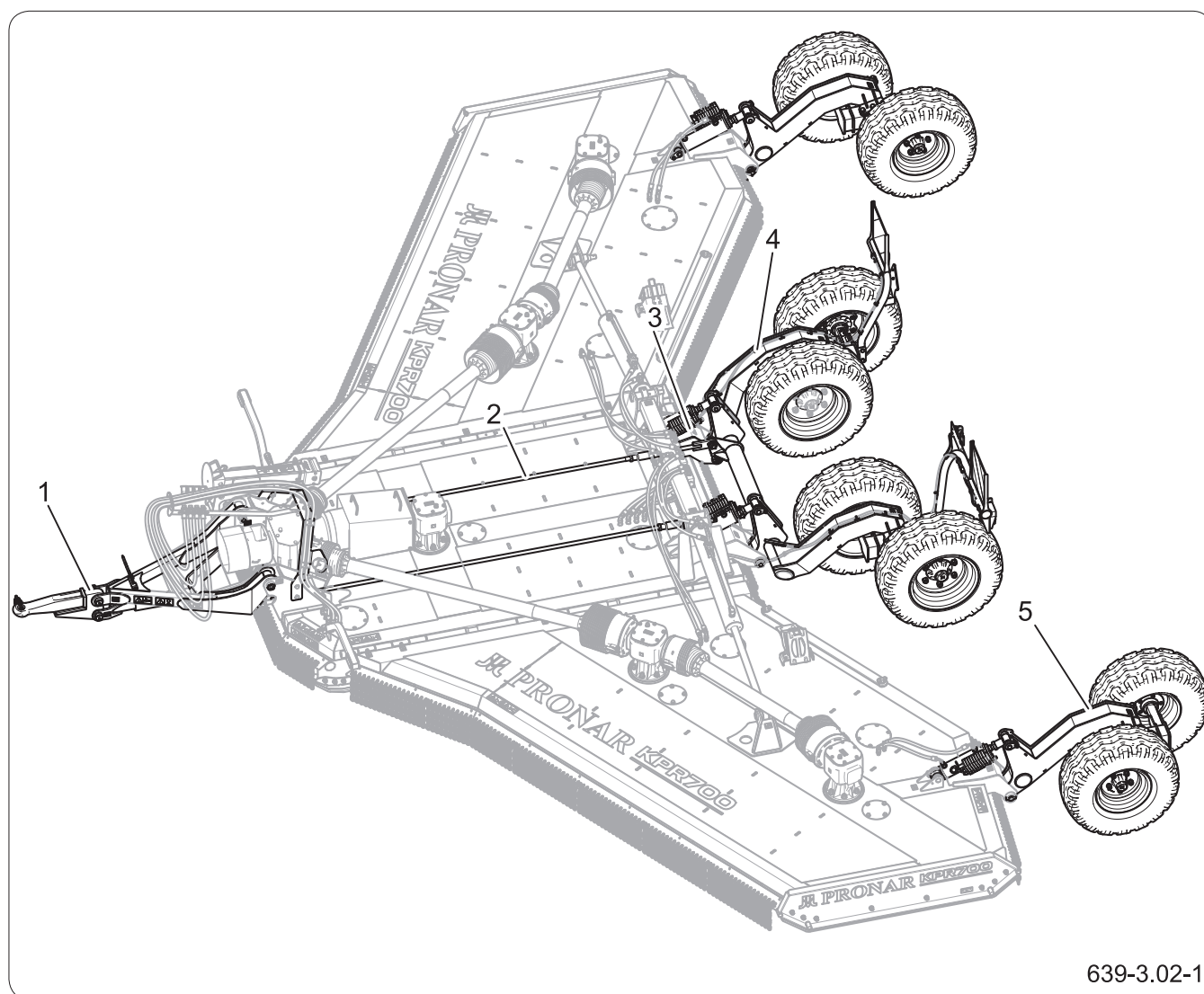

Figure 4.2 Suspension system design

(1) lower drawbar

(2) suspension link

(3) suspension cylinder

(4) mainboard suspension frame

(5) arm suspension frame

BIZ.1.1-003.01.EN

4.4 THE HYDRAULIC SYSTEM

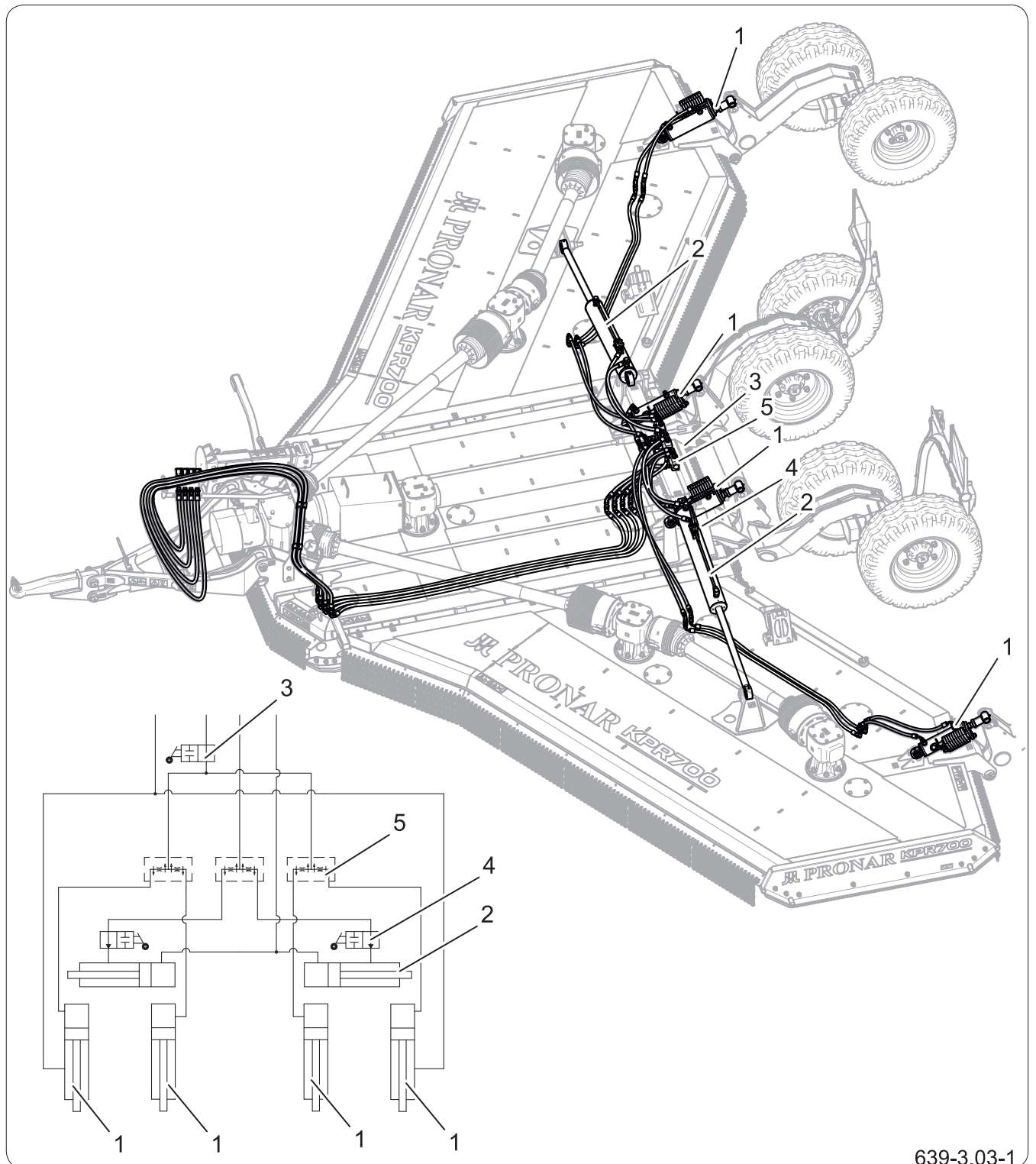

639-3.03-1

Figure 4.3 Construction of the KPR700 mower hydraulic system
 (1) suspension actuator (2) arm actuator (3) suspension actuator valve (4) arm actuator valve (5) stream divider

BIZ.1.1-004.01.EN

4.5 ELECTRICAL SYSTEM

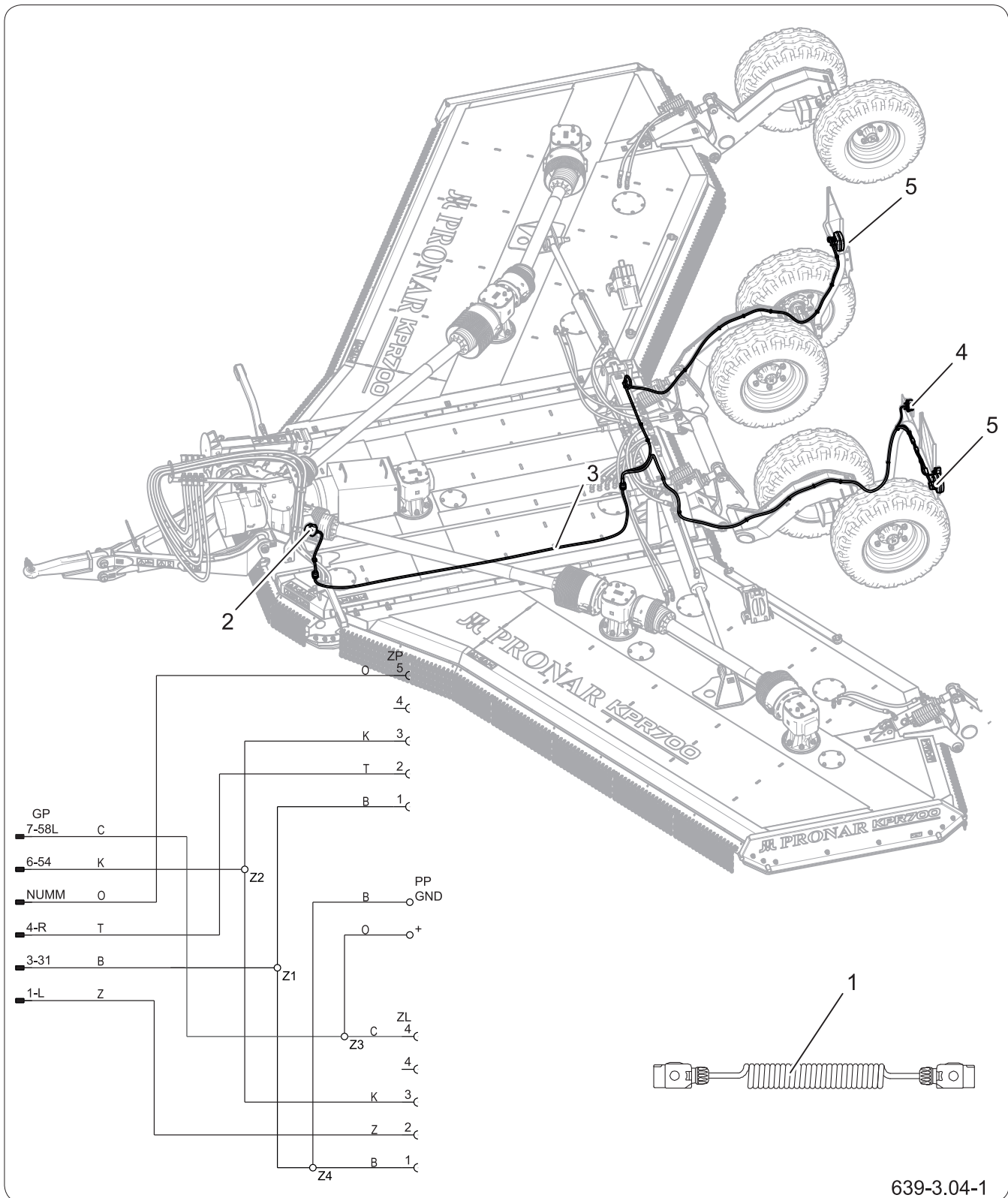

639-3.04-1

Figure 4.4 Construction of the electrical installation of the KPR700 mower

- (1) Spiral wire electric plug 7-pin 12V,
- (2) 7-pin electric plug
- (3) centre harness
- (4) license plate light
- (5) rear lamps

BIZ.1.1-005.01.EN

4.6 POWERTRAIN

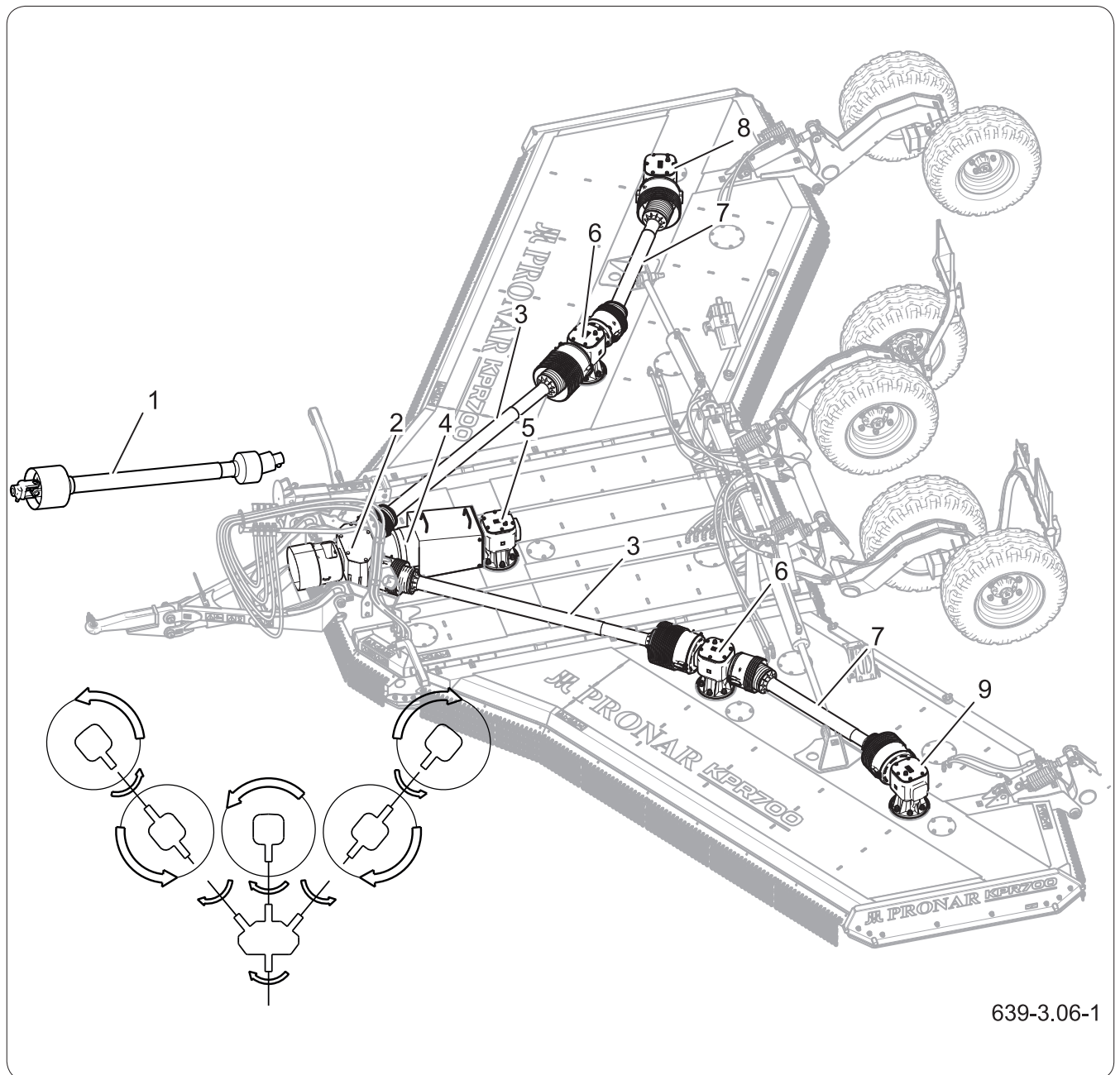

Figure 4.5 Construction of the KPR700 mower drive system

- (1) PTO shaft with overrunning clutch and wide-angle joint
- (2) splitting gear
- (3) PTO shaft of gear drive with overload clutch I
- (4) PTO shaft of gear drive with overload clutch II
- (5) bevel gear I
- (6) bevel gear II
- (7) PTO drive shaft with overload clutch III
- (8) bevel gear III
- (9) bevel gear IV

Power is transmitted from the tractor's Power take-Off (PTO) shaft (1) to the final split transmission (2). From the transmission (2), the drive is distributed to the right-angle gears (5.6.8.9) of the cutting units by means of the articulated telescopic shafts (3, 4, 7) with the overload clutch. The angle gears rotate the heads with the knives. The heads should rotate as indicated in the figure.

BIZ.1.1-006.01.EN

CHAPTER 5

RULES OF USE

PRONAR KPR700

4.1 GET READY FOR OPERATION



DANGER

Before using the machine, the user must carefully read this Operator's Manual

Careless and incorrect use and operation of the machine, and failure to follow instructions in this operator's manual is dangerous to your life and health.



DANGER

The machine must never be used by persons, who are not authorised to drive agricultural tractors (carrier vehicles), including children and people under the influence of alcohol or other drugs.

Non-compliance with the safety rules of this Operator's Manual can be dangerous to the health and life of the operator and others.



IMPORTANT

Before using the machine always check its technical condition. In particular, check the technical condition of the suspension system, drive system, protective covers and lighting (direction indicators, stop lamps, parking lights), condition of the blades and their mounting.



IMPORTANT

Before beginning work lubricate all lubrication points.

The manufacturer guarantees that the machine is fully operational and has been checked according to quality control procedures and is ready for use. This does not release the user from an obligation to check the machine's condition after delivery and before first use. The machine is delivered to the user completely assembled. Prior to connecting to the carrier vehicle (tractor), machine operator must verify the machine technical condition.

In order to do this:

- the user must carefully read this Operator's Manual and observe all recommendations, understand the design and the principle of machine operation,
- make sure that the machine's linkage is compatible with that of the carrier vehicle (tractor)
- make sure that power take-off shaft is compatible, e.g. tip type, RPM, rotation direction,
- make sure that the telescopic articulated shaft (PTO) can be connected to the tractor (the shaft should be compatible with the tractor in terms of length, type, strength, etc. - see the manufacturer's operating manual),
- check the compatibility and technical condition of the hydraulic and electric system, including compatibility of the hydraulic connectors,
- inspect machine's individual components for mechanical damage resulting from incorrect transport (dents, piercing, bent or broken components),
- check the technical condition and mounting of the blades
- check the technical condition of the suspension system components, guards and safety pins and if mounting is correct.



DANGER

Before starting the machine, ensure that there are no bystanders in the danger zone.



DANGER

When starting machine for the first time as well as after servicing the hydraulic system, extreme caution should be exercised because the aerated hydraulic system causes accelerated movement of the powered components.

If all the above checks have been performed and there is no doubt as to the machine's good technical condition, it can be connected to carrier vehicle, started and all its individual systems checked. In order to do this:

- hitch the machine to carrier vehicle (see *HITCHING TO CARRIER VEHICLE*),
- after connecting hydraulic system lines and electrical system wiring, check the correct operation of systems and inspect the hydraulic system for tightness.

In the event of a disruption in the operation of the machine immediately discontinue its use, find and remove the fault. If a fault cannot be rectified or the repair could void the warranty, please contact the Manufacturer for additional clarifications.

OBS.1.1-001.01.EN

4.2 ARTICULATED TELESCOPIC BOOM LIFT ADJUSTMENT



DANGER

Stop the tractor engine, remove the ignition key and brake the tractor with the parking brake before adjusting the shaft. Secure the tractor against unauthorized access.



CAUTION

When adjusting articulated telescopic boom lift first follow and use the instructions contained in the articulated telescopic boom lift manual.



CAUTION

Check and adjust the length of the articulated telescopic boom lift every time you change the tractor, as recommended by the articulated telescopic boom lift manufacturer. Failure to do so may result in damage to the tractor shaft, machine or PTO.



CAUTION

If the articulated telescopic boom lift is equipped with an overrunning clutch, make sure that the overrunning clutch is installed on the machine side when installing the articulated telescopic boom lift.

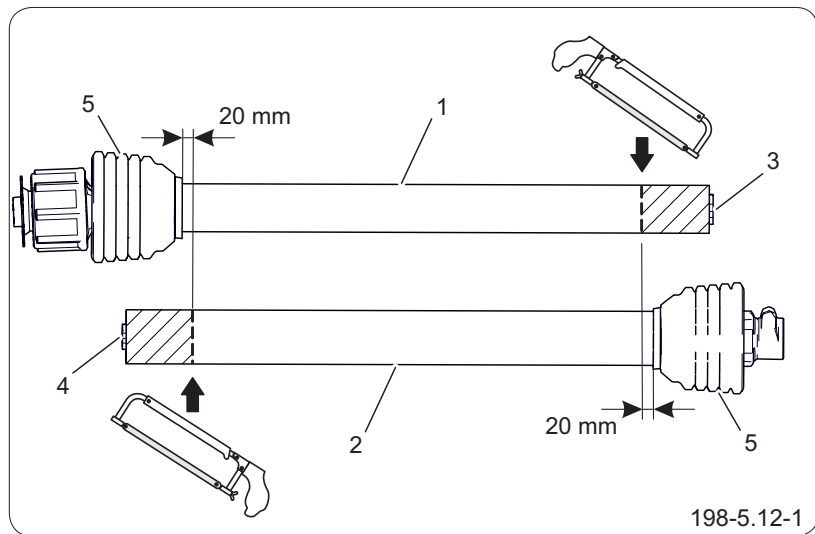

Figure 5.1 The principle of adjusting the articulated telescopic boom lift with the shortest working setting.

- | | |
|--------------------------------|------------------------------|
| (1) inner shield tube | (2) outer shield tube |
| (3) outer shaft profile tube | (4) inner shaft profile tube |
| (5) cross joint tapered guards | |

Adjust the length of the articulated telescopic boom lift before the first start-up.

For this purpose:

1. Attach the machine to the tractor suspension system
2. Position the machine so that the distance between the tractor's Power take-Off (PTO) terminals and the machine is the smallest.
3. Slide the articulated telescopic boom lift shield into two parts (1) and (2).
4. Install one part of the shaft on the tractor PTO end.
5. Install the second part of the shaft onto the PTO end of the machine.

The shaft assembly procedure is specified in detail in the shaft manufacturer's operating instructions.

6. Position the two parts of the shaft guard (1) and (2) parallel to each other.

ADVICE

Use a hand-held metal saw to shorten shaft guards and profile pipes.

7. Mark the location where the guard tubes should be shortened with a minimum clearance. 20 mm from the tapered roller guards (5) of the shaft cross joints.
8. Shorten the guard tubes (1) and (2) at the selection point.
9. Shorten the profile tubes (3) and (4) by the same length as the guard tubes (1) and (2).
10. Sharp edges of profile pipes (3) and (4) gently walk with a file and remove any metal swarf.
11. Coat the outer surface of the inner profile tube (4) with grease.
12. Slide the profile tubes (3) (4) and guard tubes (1) (2) off the shaft.
13. Make sure that the profile tubes (3) and (4) overlap with the greatest distance between the tractor and machine PTO ends is sufficient.

Refer to the shaft manufacturer's manual for details on shaft alignment and inspection.

OBS.1.4-026.01.EN

4.3 THE DRAWBAR EYE PROTECTION



CAUTION

Always secure the machine when it is disconnected from the machine by securing the tie rod.

Use appropriate protection depending on the drawbar tie rod installed. For a rotating or fixed link, use a chain (3), the ball link requires a lock (4).

Removal of the protection

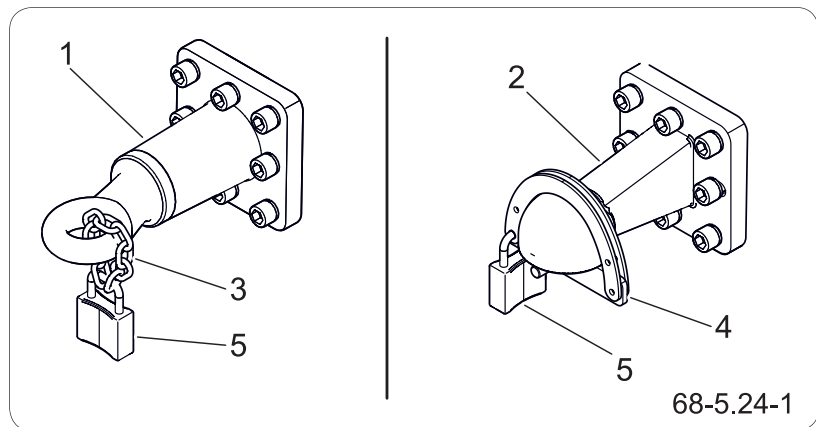

Figure 5.2 The drawbar eye protection

- | | |
|-------------------------|----------------|
| (1) rotating/fixed link | (2) ball link |
| (3) chain | (4) protection |
| (5) padlock | |

1. Open the padlock (5).
2. Unfasten the chain (3) or the safety device (4) from the tie rod.
3. Remove the lock, lock the safety components with a padlock.
4. Protect the padlock key (5) from being lost.

Fitting of the protection

1. Open the padlock (5).
2. Install the chain (3) or the safety device (4) on the tie rod.
3. Close padlock (5).
4. Protect the padlock key (5) from being lost.

OBS.3.C-008.01.EN

4.4 CARRIER LOADING

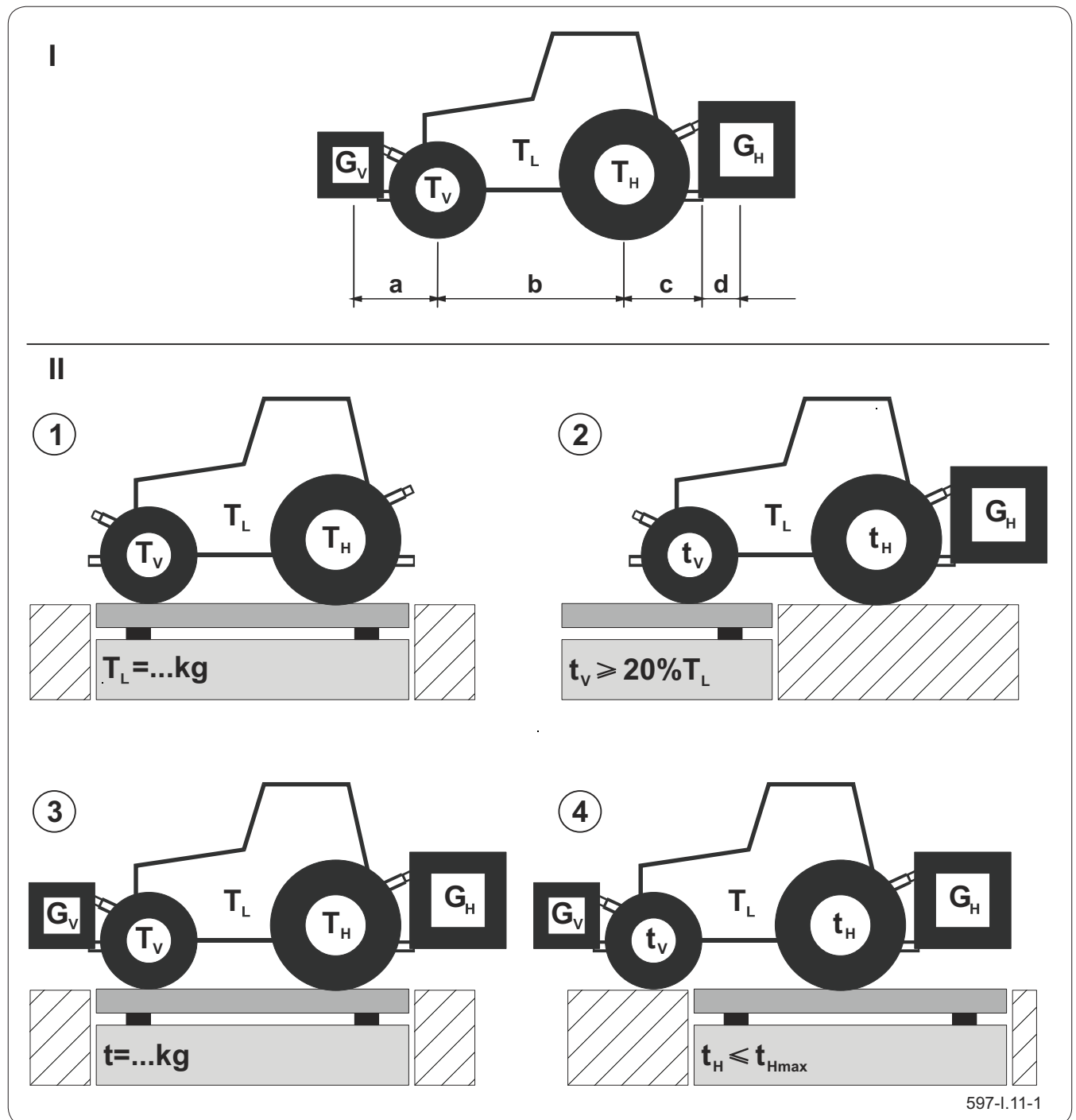

Figure 5.3 Loading of the tractor

**CAUTION**

The load on the front axle of the tractor must be at least 20% of its own weight and the load of the aggregated machine.

Before attaching the machine to the tractor, check the suitability of your tractor for this purpose. Suspension of tools in the three-point linkage at the front or rear must not exceed the permissible total weight, permissible axle load and load capacity of tractor tires. The



CAUTION

Incorrect use of the tractor may cause breakage, insufficient stability and the ability to steer and brake the tractor.

front axle of the tractor must always be loaded with at least 20% of the tractor's own weight and the load of the aggregated machine.

To ensure that these conditions are met, perform the following calculations:

CALCULATION OF MINIMUM FRONT BALLAST G_{Vmin}

$$G_{Vmin} = \frac{G_H \cdot (c+d) - T_V \cdot b + 0,2 \cdot T_L \cdot b}{a + b}$$

Table 5.1. Carrier loading

Symbol / dimensions	Unit	Description
T_L	kg	Carb weight of the tractor
T_V	kg	The load on the front axle of the tractor without the machine
T_H	kg	The load on the rear axle of the tractor without the implement
t	kg	Axle load of the tractor with the machine
t_V	kg	The load on the front axle of the tractor with the machine
t_H	kg	The load on the rear axle of the tractor with the machine
G_H	kg	Total weight of the rear-attached machine or rear weight
G_V	kg	The total weight of the front-attached machine or front weight
a / and	m	Distance between the centre of gravity of the front-mounted machine/front load and the centre of the front axle
b	m	Tractor wheelbase
c	m	Distance from the centre of the rear axle to the centre of the tractor lower links
d	m	Distance from the centre of the tractor's lower links to the centre of gravity of the rear-attached machine or rear weight

CALCULATION OF MINIMUM REAR BALLAST G_{Hmin}

$$G_{Hmin} = \frac{G_V \cdot a - T_H \cdot b + 0,45 \cdot T_L \cdot b}{b + c + d}$$

The calculation of the required minimum front and rear ballast assumes that all parameters are known. If the parameters are not known and cannot be determined, measurements should be made using a scale.

MEASUREMENT OF PERMISSIBLE AXLE LOADS USING A SCALE

Measure the curb weight of the tractor (T_L).

Hitch the machine to the tractor and measure the front axle load (t_V). If the load is less than 20% of the weight of the tractor alone (T_L), add weights to bring the load above the minimum value ($t_V \geq 20\% T_L$).

Measure the total weight (t) of the tractor with the machine and weights. Check the tractor manual to see if the measured value is less than the Average Gross Weight.

Measure the load on the rear axle (t_H) and check in the tractor manual whether the measured value is lower than the permissible maximum value of the load on the rear axle of the tractor (t_{Hmax}).

OBS.2.9-002.01.EN

4.5 OPERATION OF THE MECHANICAL PARKING STAND



CAUTION

It is forbidden to start and drive with the support lowered.

Make sure that the support is fully raised and folded down before driving. It is essential to secure the support foot with the safety pin.



DANGER

Take special care when operating the support - it also applies to bystanders or helping people, there is a risk of crushing limbs.

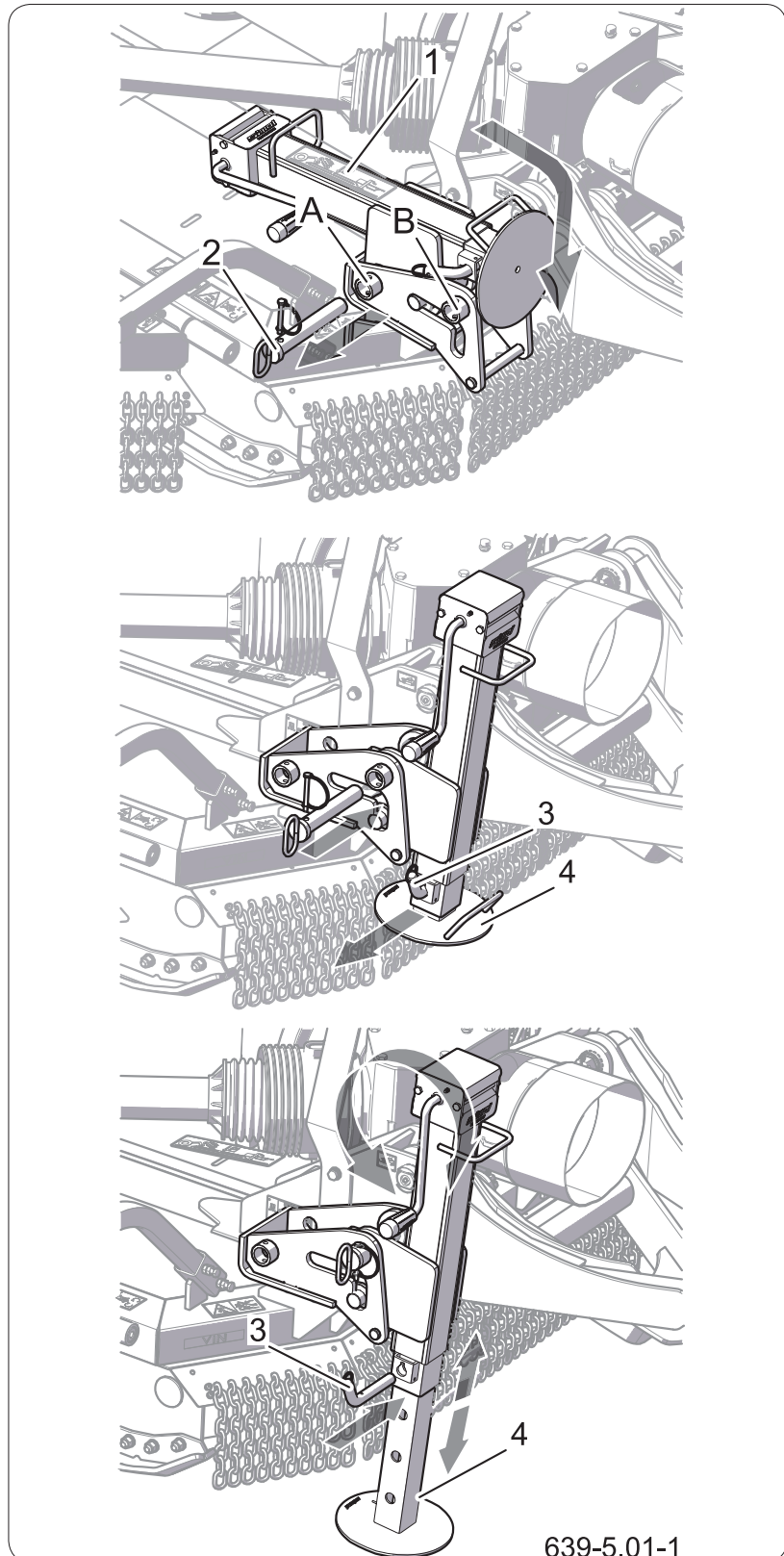

Figure 5.4 The mechanical support

(1) support

(2) pin I

(3) pin II

(A) A-pin socket

(2) pin I

(4) support foot

(B) A-pin socket

Operation of the mechanical support

1. Secure the machine against rolling.
2. Position the tractor in such a way that the tractor's hitch is directly in front of the machine's drawbar eye.
3. Switch off the tractor engine.
4. Apply the tractor parking brake.

Raising of the support

1. Turn the crank to the maximum lift of the support leg
2. Unlatch and remove pin II (3)
3. Slide the leg of the support as far as possible and secure it with pin II.
4. Release and remove pin I (2) from slot B.
5. Move the support (1) from the vertical position to the horizontal (transport) position.
6. Install the safety pin (2) in slot a and secure with the cotter pin.

Lowering of the support

1. Release and remove pin I (2) from slot A.
2. Move the support (1) from the horizontal to the vertical position.
3. Put the safety pin (2) in socket B and secure it with a cotter pin.
4. Unlatch and remove pin II (3)
5. Extend the support leg as far as possible and secure it with the pin II
6. Turn the crank to lower the leg of the jack stand so that the machine can be disconnected from the tractor.

OBS.1.1-004.01.EN

4.6 SUSPENSION ADJUSTMENT OPERATIONS

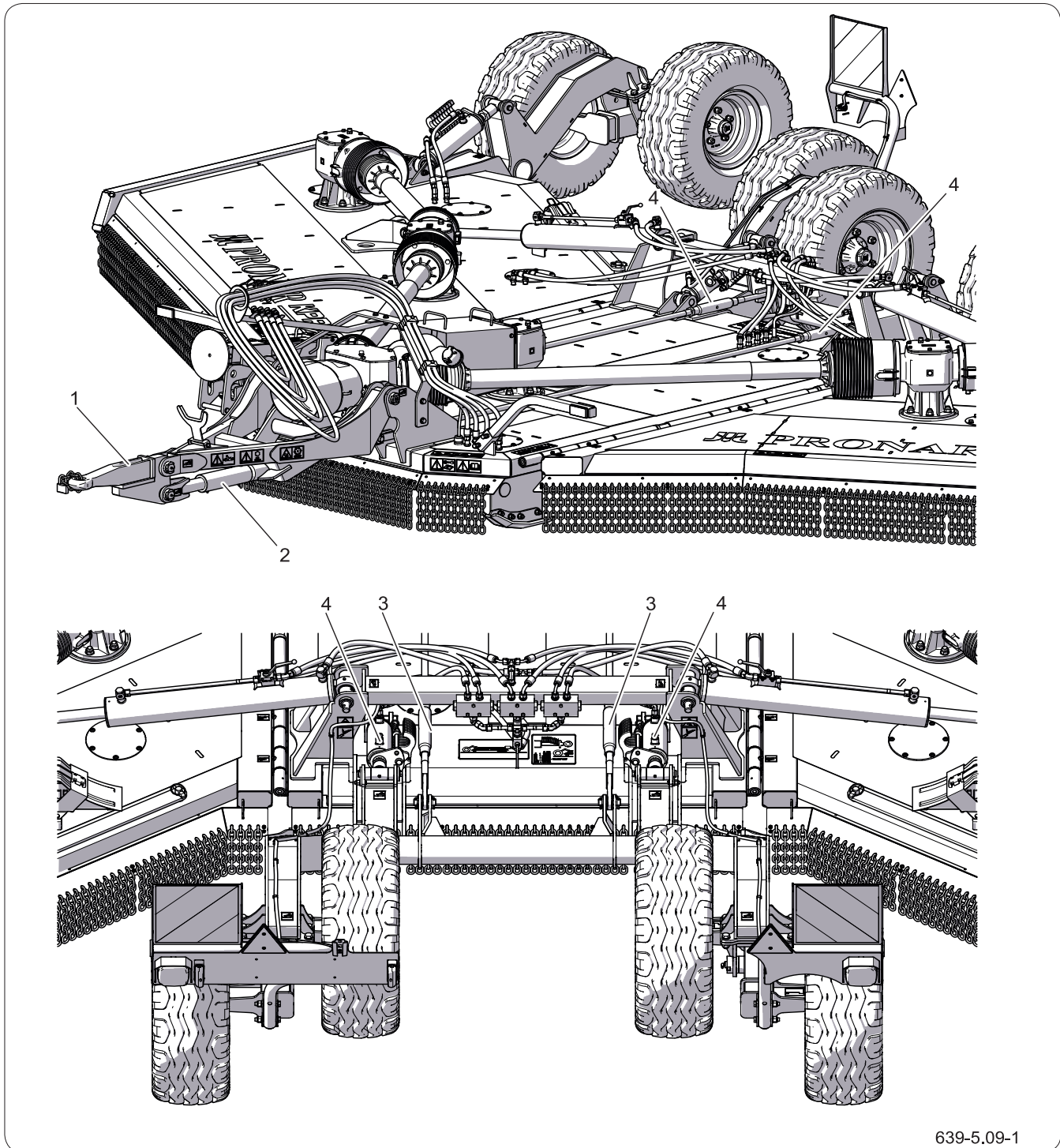

639-5.09-1

Figure 5.1 Adjusting of the machine position

(1) drawbar eye (2) eye bolt (3) suspension eye

(4) suspension cylinders

To set the optimum operating conditions, the machine position can be adjusted in several planes:

- The cutting height is adjusted by the suspension cylinders (4) with the locking plates.

- To level the drawbar (1), use the tie rod with the turnbuckle (2) under the drawbar.
- To adjust the mower tilt, use the tie rods (3) located at the rear of the mower and the tie rod bolt under the drawbar (2).

Levelling of the tie rod

It is recommended that the drawbar tie-rod (1) be horizontal - parallel to the ground surface during transport and operation. The drawbar position is adjusted with the screw (2) located under the tie rod; extending the

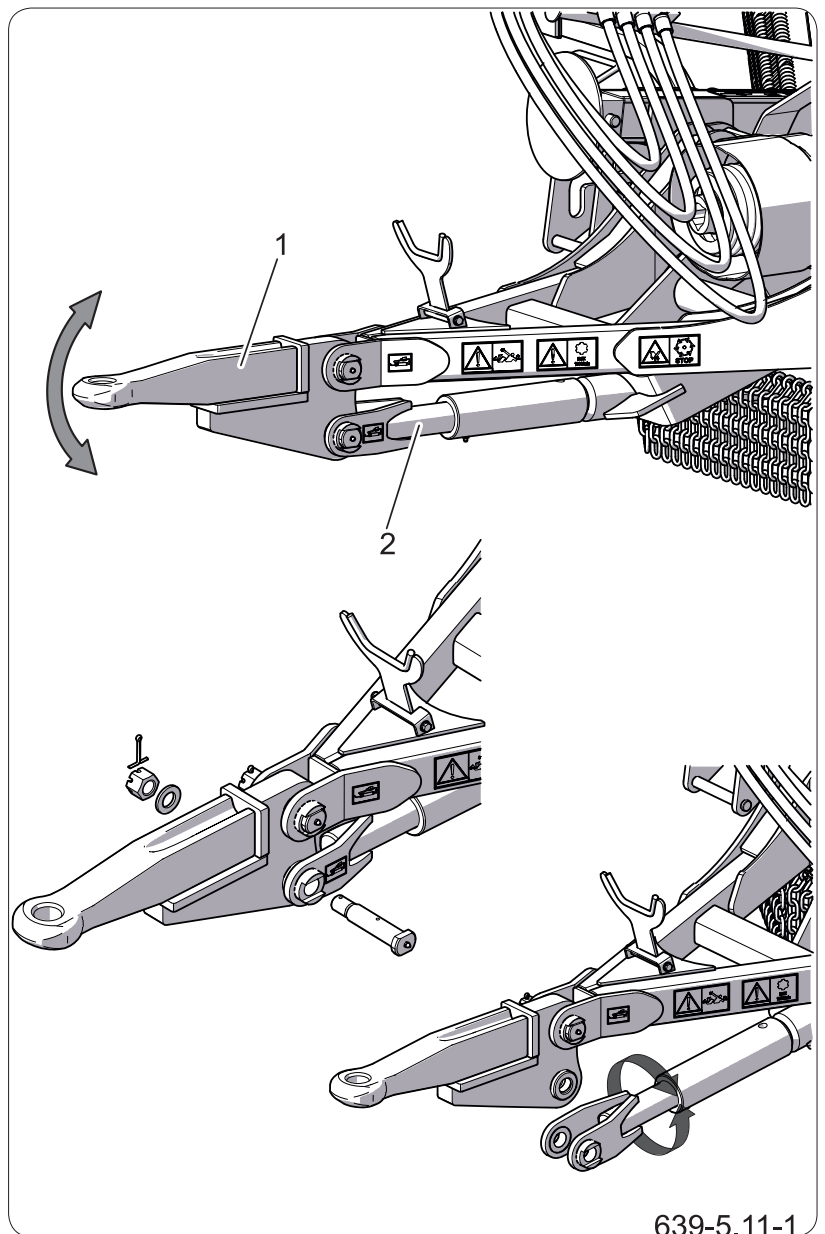

Figure 5.2 Drawbar tilt setting
(1) drawbar eye (2) eye bolt eye

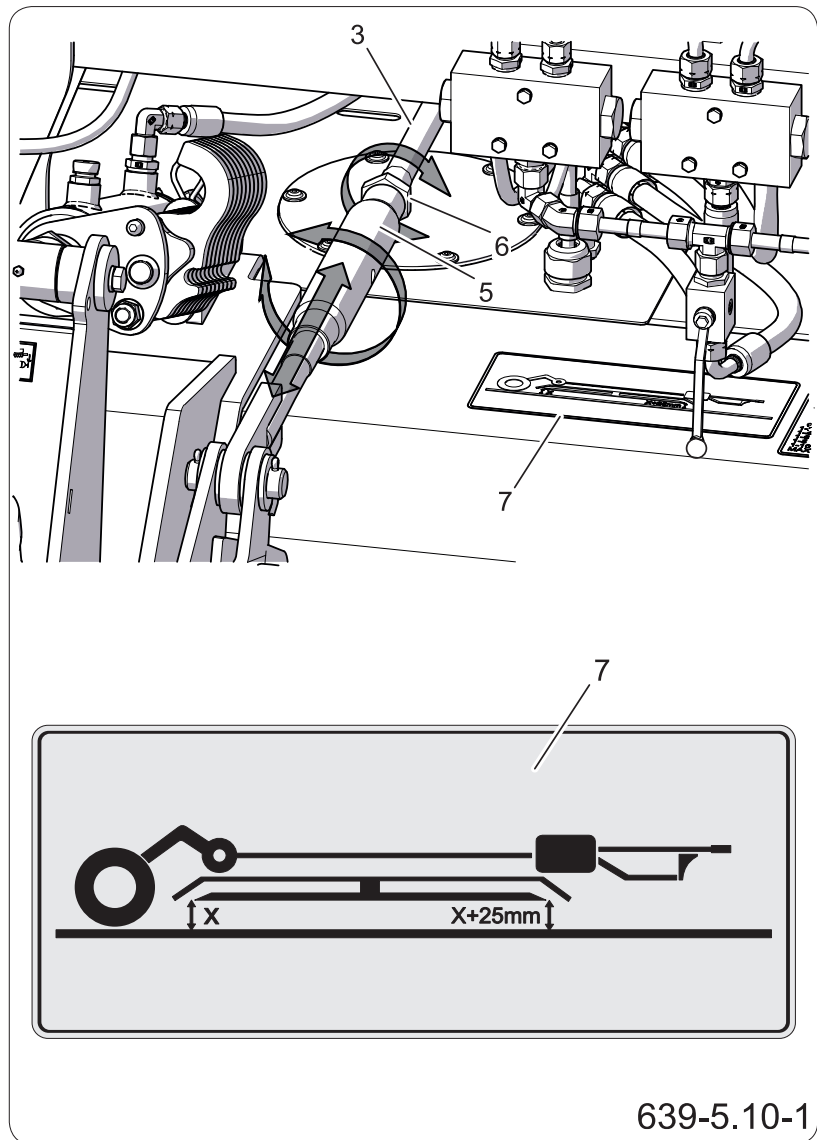

Figure 5.3 Adjusting of the mower tilt

(3) drawbar eye (5) turnbuckle of the eye
 (6) locknut (7) information decal

bolt raises the tongue tie rod, shortening - lowering the tie rod.

Levelling of the machine

The best cutting conditions are obtained when the front of the mower is raised 12-25mm relative to the rear of the machine - see information decal (7). To adjust the lift of the machine:

- loosen the lock nuts (6)
- turn the screws (5) of the suspension tie-rods (3) lengthening or shortening the tie-rod. It is important to rotate the tie rod bolt in the same

direction and by an equal number of turns.

- when the plate is inclined, check the tie-rod bolt with nut (6)

Cutting height

Set the cutting height according to the chapters *Connecting the mower to the tool carrier (tractor)* and *Work with the mower*.

OBS.1.1-014.01.EN

4.7 CONNECTING OF A MOWER WITH IMPLEMENT CARRIER (TRACTOR)



DANGER

Use only original pins and safety devices to connect the machine to the carrier (tractor).



DANGER

During coupling there must be no third parties between the mower and the tractor. The agricultural tractor operator when connecting the machine should take particular care during work and make sure that unauthorized persons are not in the danger zone during coupling.



DANGER

Depressurize the system before connecting the machine to the hydraulic system.

ADVICE

The alignment of the implement carrier (tractor) PTO shaft with the machine drive shaft greatly extends the life of the drive shaft.



CAUTION

Pay attention to the compatibility of oils in the tractor hydraulic system and in the hydraulic system of the mower.

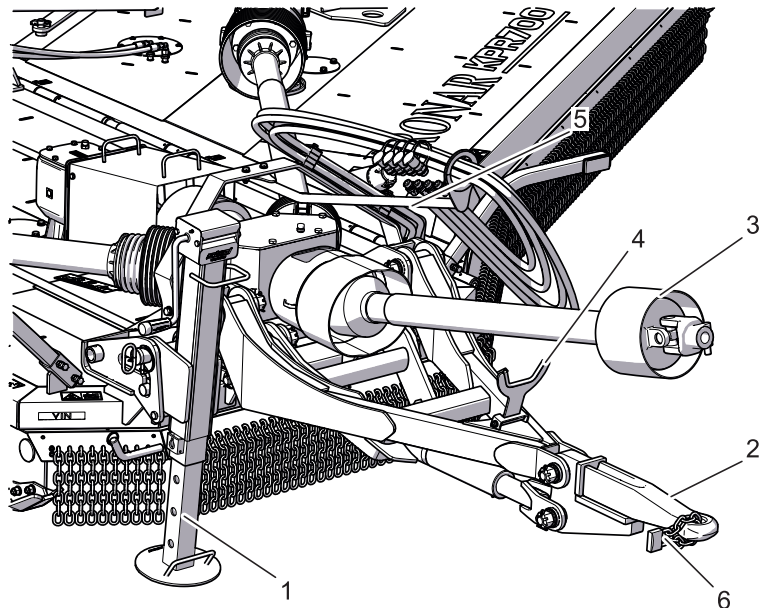

639-5.13-1

Figure 4.1 shows how to connect the mower to an agricultural tractor. If all connections (electrical, hydraulic) and the hitch on the agricultural tractor are in accordance with the machine manufacturer's requirements.

The wheels of the machine must be chocked.

Ensure good visibility during coupling.

In order to connect the mower with the tractor, perform the following actions in order.

Connecting (Figure 4.1):

- Remove the safety device (6).
- Position the agricultural tractor directly in front of the drawbar eye (2).
- Using the support (1), position the drawbar tie rod (2) at a height that allows the machines to be connected.
- Reverse the tractor, connect the mower to the hitch, check the coupling safety device protecting the machine against accidental unhitching.
- If an automatic coupling is used in the agricultural tractor, make sure that the aggregation

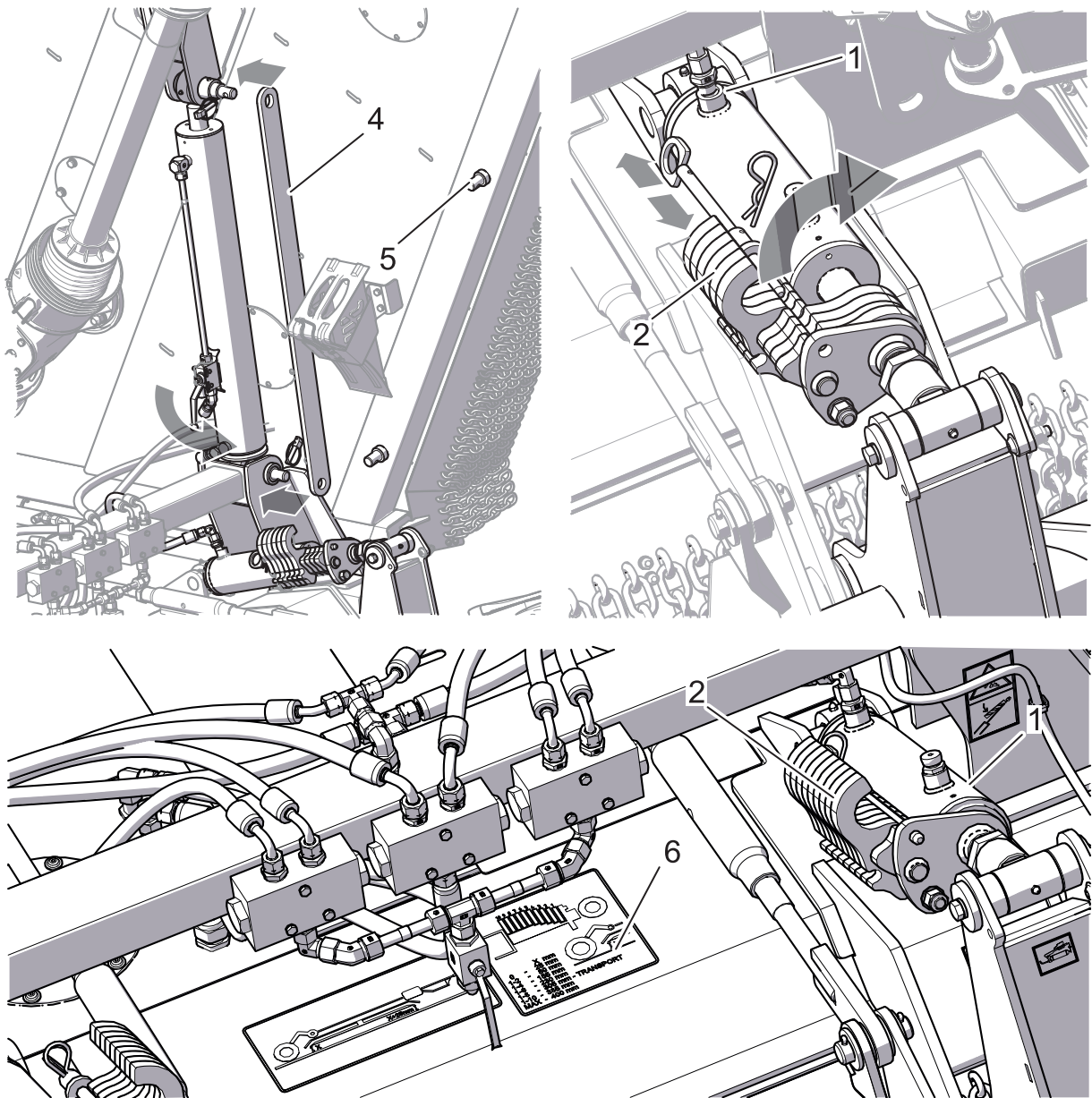

639-5.01-1

Figure 5.6 Transport locks

- (1) suspension cylinder (2) adjusting plates (3) arms cylinder
 (4) cylinder lock (5) lock sling on the mower's arm (6) information table

operation is completed and the drawbar eye is secured.

Switch off the tractor engine. Close the tractor cabin and secure it against unauthorized access.

- Connect the hydraulic hoses for the suspension and arms unfolding
- The hydraulic lines are colour coded.
- Connect the main power supply cable for the lighting installation.
- Connect the PTO shaft (3) (PTO) to the PTO of the carrying vehicle (tractor) and secure it with safety chains.
- When aggregation is complete, the support foot



DANGER

Before connecting the PTO shaft, it is essential to read the instructions attached by the shaft manufacturer and follow all the recommendations contained therein.

Before connecting to the carrier, check the technical condition of the shaft covers, completeness and condition of the protecting chains.



CAUTION

The hydraulic and electrical lines must be routed so that they do not get caught in moving parts of the machine and the carrier and are not exposed to breakage or pinching during a turn. .



DANGER

Take special care when folding the support – risk of pinching the limbs.



CAUTION

Raising and lowering the mower blades with the PTO engaged could damage the machine.



CAUTION

Before connecting the hydraulic and electrical system conduits, read the carrying vehicle's manual and follow the manufacturer's instructions



DANGER

The mower can only be transported with the telescopic shaft disconnected.

should be fully retracted and folded into the transport position.

- Start the tractor, raise the mower as far as it will go (the mower should have arms folded, locked by cylinder locks (4) the ball valves should be in the "closed" position, switch the tractor off again.
 - Adjust the number of adjustment plates (2) indicated on the decal (6) to match the transport position.
 - Start the tractor, lower the mower so that the suspension cylinder (1) of the centre plate is resting on the adjustment plates (2)
 - Secure the suspension cylinders with a ball valve
- The machine is ready for transport.

OBS.1.1-003.01.EN

4.8 WORK WITH THE MOWER



DANGER

Keep persons away from the machine during service.



DANGER

When driving the machine in transport position on uneven terrain, use extreme caution and reduce ground speed due to the possibility of damage and/or tipping of the media with the machine.

Preparation to work

When the machine is transported to the work area, change the machine configuration from transport to work position. To do this, place the tractor with the mower on a flat surface and on a stable surface. Then:

- Switch off the tractor engine. Close the tractor cabin and secure it against unauthorized access.
- Remove the arm transport locks,
- Open valve hydraulic hoses for the suspension and arms unfolding,
- Start the tractor, lower the arms, move the hydraulic section responsible for moving of the arms in the float position,
- Raise mower suspension as far as possible
- Switch off the tractor engine. Close the tractor cabin and secure it against unauthorized access.
- On the suspension cylinders, adjust the number of adjustment plates corresponding to the desired cutting height, see figure *Cutting height*,

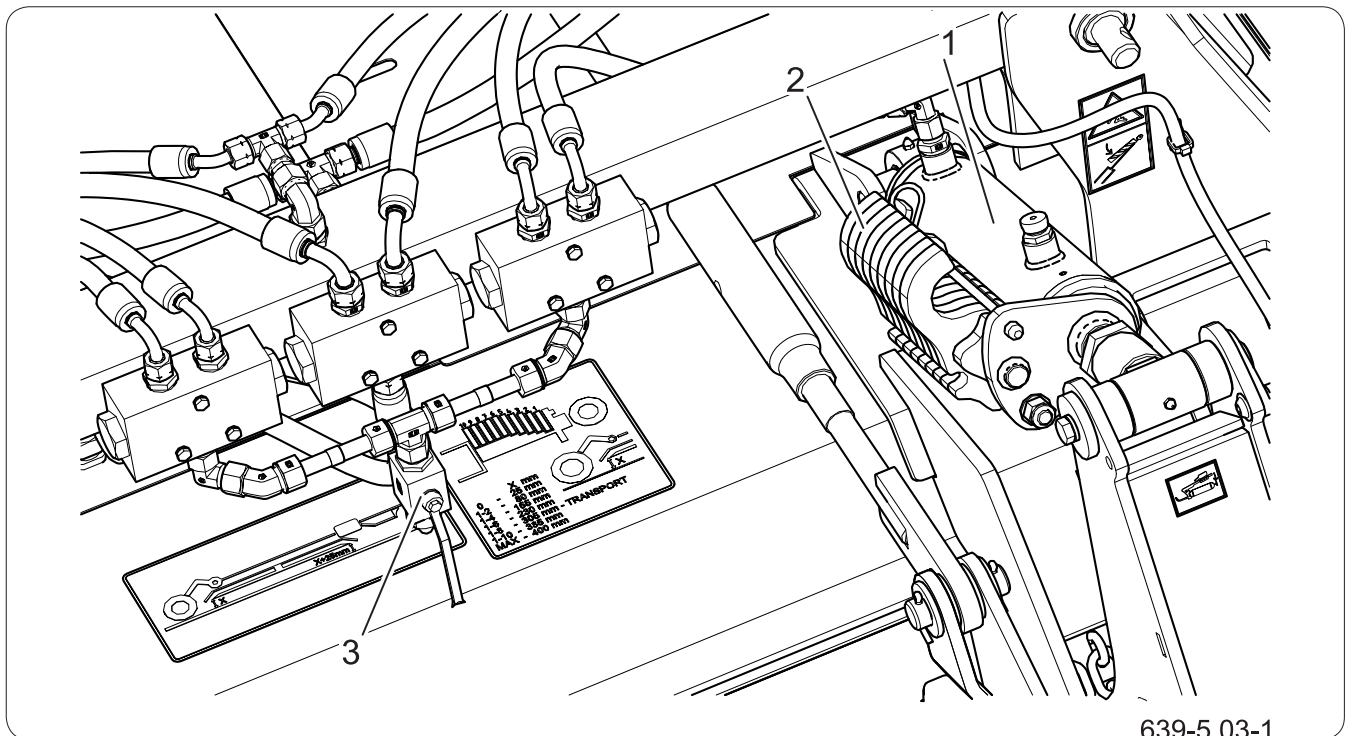

639-5.03-1

Figure 5.1 Transport locks II

(1) suspension cylinder (2) adjusting plates (3) cylinder valve

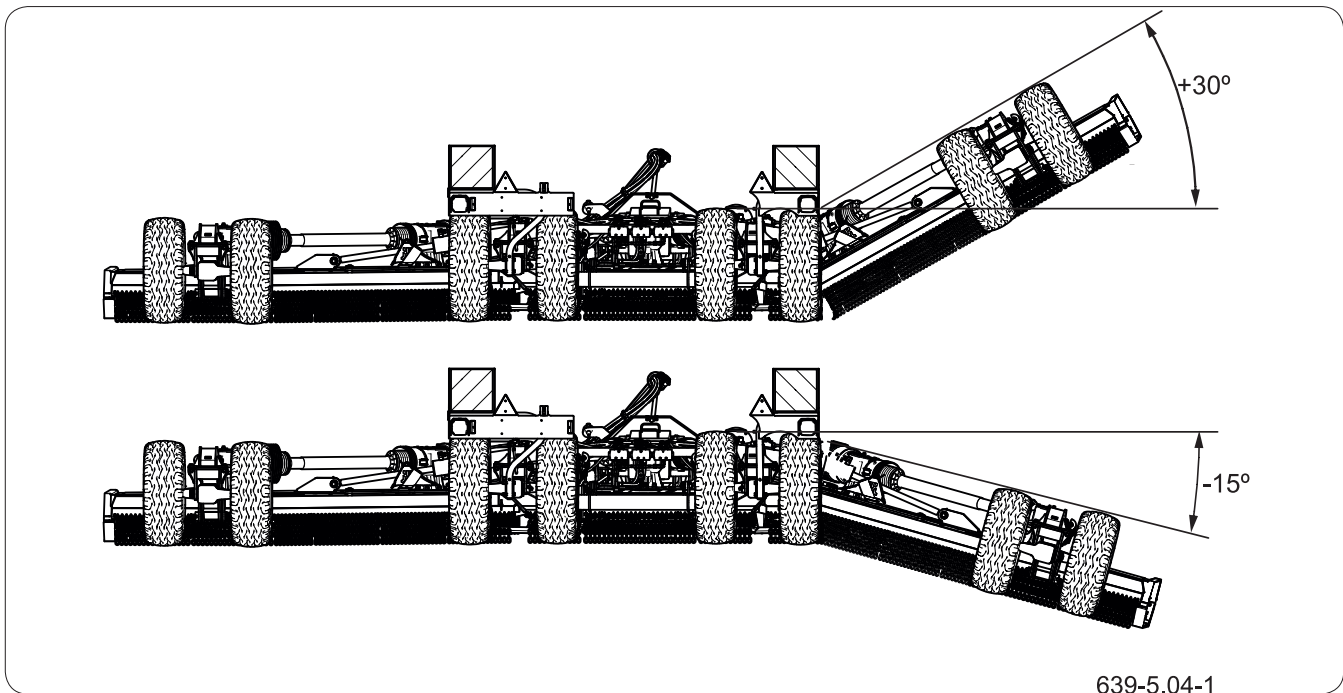

639-5.04-1

Figure 5.7 Work with mower on a slope - Terrain copying



DANGER

Disengage the PTO before lifting the mower arms. Engaging the drive while lifting or when the arms are raised will damage the telescoping shafts and the transmission.



DANGER

Do not allow people or animals to stay within 100 m of the machine while the mower is operating. Operate from tractor only.



DANGER

It is forbidden to occupy any position other than the operator's position in the vehicle cabin while working with the equipment. It is forbidden to leave the operator's cabin while the machine is working. Do not stay between the carrier and the machine. It is forbidden for the operator to stay near the machine until the cutting heads have stopped.

- Start the tractor and lower the mower suspension until the suspension cylinders rest against the adjustment plates.
- Connect the PTO shaft.

Remove debris, rocks, wires, cables, metal objects, and other foreign material from the work area before working on wasteland. Wire, cable, rope, chains and metal objects can be thrown out, tangled in the

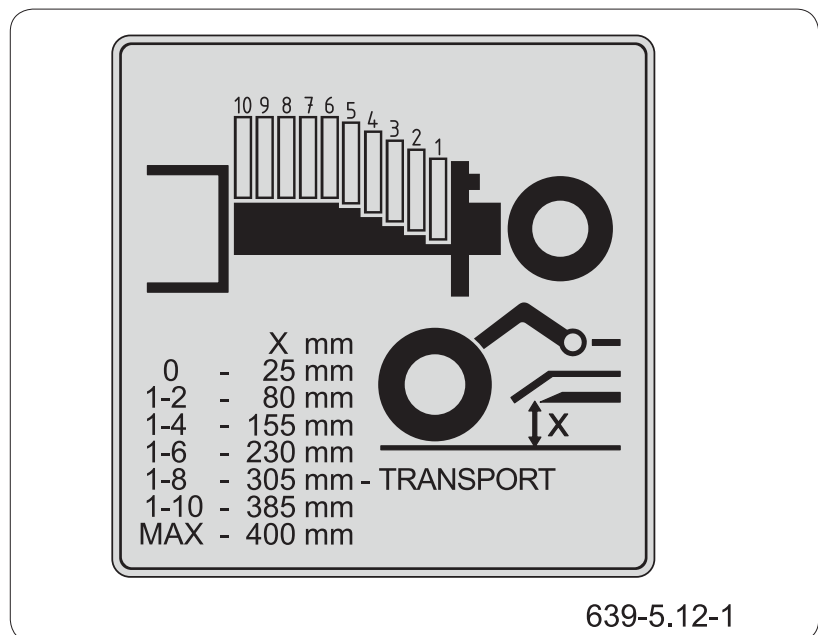

639-5.12-1

Figure 5.8 Cutting height

**DANGER**

Before starting the carrier engine, make sure that the PTO drive is turned off. Otherwise, the mower may start uncontrollably and be life-threatening. The mower drive can only be started if all the safety guards are correctly fitted. Before engaging the PTO drive, make sure that there are no bystanders near the mower.

**CAUTION**

Do not cut any material other than plants.

**DANGER**

The mower can only be transported with the telescopic shaft disconnected.

cutterhead and turned at high speed:

- Mark objects that cannot be deleted.
- Avoid these objects when mowing.

Work with the mower

The mower is only used in forward travel. Do not mow when driving backwards. The mower arms have the ability to copy the ground while working, it is possible to cut on irregularities in the range 25° down and 30° up (figure "*Working with the mower on a slope - Copying of the ground*").

Control of high grass and brush on wasteland:

- CONTROL and REMOVE any hidden, large debris.
- Cut at intermediate height.
- Inspect and remove any remaining debris.
- Cut at the target height.

Stop cutting immediately if the blades hit heavy objects, solid structures, metal barriers or concrete. Check the condition of the mower.

To avoid serious injury or death:

- Keep **bystanders** at least 100 meters away from the work area.
- All **guards**, including chain guards, are in place and are in good condition when cutting.
- **The mowing area** must be checked and foreign material and debris has been removed.
- There are no bystanders around.

After completion of field work

Proceed as follows:

- Disengage the tractor PTO and wait until the mower knives and telescoping shafts come to a stop.
- Raise arms to transport position.
- Raise mower suspension as far as possible
- Shut off the tractor engine, remove the ignition key, apply the parking brake. Close the tractor

cabin and secure it against unauthorized access.

- Reinstall the arm transport locks.
- Adjust the number of adjustment plates corresponding to the transport position on the suspension cylinders of the centre plate.
- Start the tractor and lower the mower suspension until the suspension cylinders rest against the adjustment plates.
- Shut off the tractor engine, remove the ignition key, apply the parking brake. Close the tractor cabin and secure it against unauthorized access.
- Close valve hydraulic hoses for the suspension and arms unfolding.
- Disconnect the IDL from the PTO of the carrier.
- Clean the machine of any crop residue.

OBS.1.1-005.01.EN

4.9 CONNECTING AND DISCONNECTING OF THE HYDRAULIC SYSTEM

Requirements



DANGER

Operation of a disabled machine is prohibited.

Be especially careful, the hydraulic system may be under high pressure.



CAUTION

Secure the disconnected wires with plug caps and place them on the wire support.

1. Immobilize the the machine against rolling.
2. Connect the machine tie-rod to the tractor hitch.
3. Switch off the tractor engine.

Connecting of the installation

1. Check the condition and cleanliness of the hose plugs and the hydraulic distributor on the tractor.
2. Connect the hydraulic plugs (1) to the corresponding sockets on the tractor auxiliary hydraulics

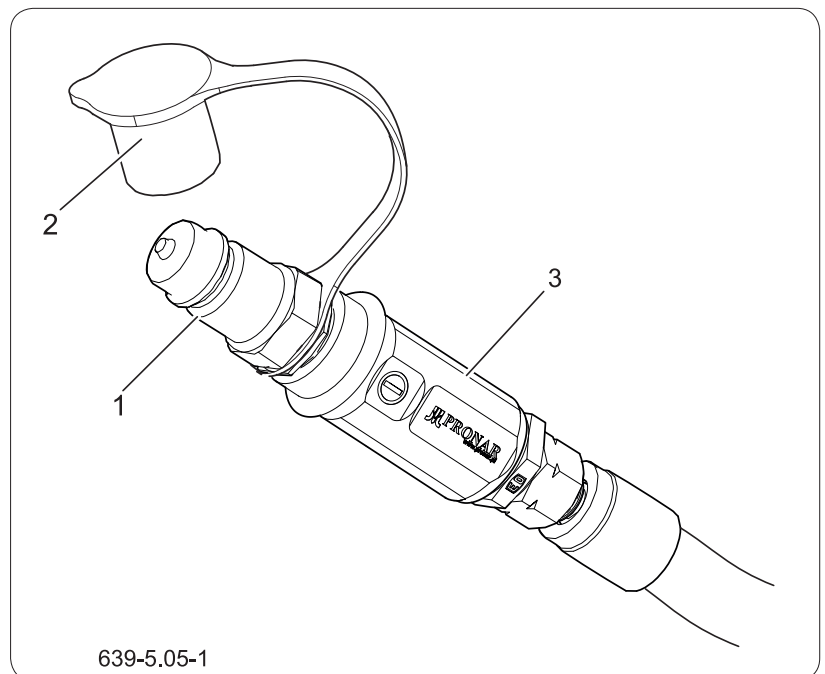

Figure 5.9 Hydraulic system connections
 (1) hydraulic plug (2) colored plug
 (3) colored straight nipple (Kennfixx)

Hydraulic conduits of individual circuits are marked with appropriate colours.

Kenfixxx plugs (colour coding):

blue "+" - raising of the mower's suspension

blue "-" - lowering of the mower's suspension

red "+" – raising of the arms

red "-" – lowering of the arms

Disconnecting of the installation

1. Reduce the residual pressure of the machine hydraulic system with the tractor hydraulic system.

Due to the variety of hydraulic systems of agricultural tractors, the machine manufacturer is not able to determine the universal method of reducing the pressure in the hydraulic system. Refer to the operator's manual for your agricultural tractor.

2. Disconnect the hydraulic line plugs (1) from the tractor distributor sockets.
3. Place the cable plugs (1) on the cable bracket.

Reduction of residual pressure

The hydraulic system is designed in such a way that there is no residual pressure when the machine is operated properly. When the machine is operated, there may be situations where hydraulic pressure is present. In this case, you can try to push the quick coupler poppet or slightly loosen the hydraulic coupler.

OBS.1.1-010.01.EN

4.10 CONNECTING AND DISCONNECTING OF THE ELECTRIC SYSTEM

Requirements



CAUTION

Before driving, check the operation and completeness of the electrical system.

It is forbidden to drive with inefficient lighting system.

1. Immobilize the the machine against rolling.
2. Connect the machine tie-rod to the tractor hitch.
3. Switch off the tractor engine.

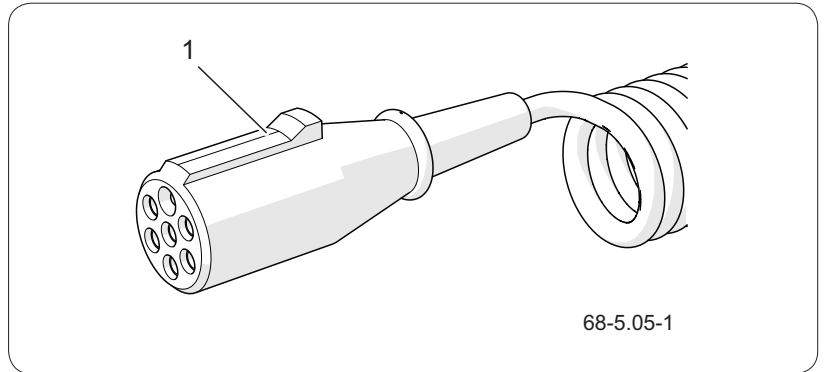

Figure 5.10 Electric system connections
(1) 7-pin wire

Connection

1. Connect the main cable (1) powering the lighting electrical system (7-pin).
2. If the tractor does not have the correct sockets or if the sockets are of a different type, have them installed by qualified personnel.

Disconnect

1. Disconnect the power cord.
2. Secure the tractor and machine sockets with the covers.

OBS.1.1-011.01.EN

4.11 DRIVING ON PUBLIC ROADS

When driving on public roads, respect the road traffic regulations, exercise caution and prudence. Listed below are the key guidelines.

- Before moving off make sure that there are no bystanders, especially children, near the machine and the carrier vehicle (tractor). Ensure that the driver has sufficient visibility.
- Make sure that the machine is correctly attached to the carrier vehicle (tractor), and linkage is properly secured.
- Do not exceed the maximum speed allowed by road traffic regulations. Ground speed should be adjusted to existing road conditions, pavement condition and other conditions.
- While driving on public roads, the machine should be marked with slow-moving vehicle warning sign placed on the rear of the machine.
- Avoid ruts, depressions, ditches or driving on roadside slopes. Driving across such obstacles could cause the machine and the carrier vehicle to suddenly tilt. Driving near ditches or canals is dangerous as there is a risk of the wheels sliding down the slope or the slope collapsing.
- Speed must be sufficiently reduced before making a turn or driving on an uneven road or a slope.
- When driving on uneven terrain, reduce speed due to dynamic loads and the risk of damage to the machine or tractor.

Take account of the following:

- When driving with the machine's wings raised, these may limit the operator's view.

- When driving, secure the wings against unfolding using the cylinder lock and use the cylinder adjustment plates prevent the machine suspension system from automatic dropping.

OBS.1.1-006.01.EN

4.12 RULES FOR THE USE OF TIRES

- When working with tires, the machine should be secured against rolling by placing chocks under the wheels.
- Repair work on wheels or tires should be performed by persons trained and authorized for this purpose. These works should be performed with the use of appropriately selected tools.
- Inspect the tightness of the wheel nuts before the first use of the machine, after the first use and driving about 5 km, then after each day of work during the first month of using the machine, and then every 50 hours of driving. Always repeat all operations if the wheel was disassembled. Wheel nuts should be tightened in accordance with the recommendations contained in the *Inspections and technical service* chapter.
- Regularly check and maintain proper tire pressure as recommended in the instructions (especially after a long break in the machine use).
- Tire pressure should also be checked during all-day intensive work. Take into account that an increase in tire temperature can increase the pressure by up to 1 bar. With this increase in temperature and pressure, reduce the load or speed of the machine.
- Never reduce the pressure by venting if it increases due to temperature.
- Valves must be secured with appropriate caps to avoid soiling.
- Do not exceed the machine speed limit.
- Avoid damaged surfaces, sudden and variable manoeuvres, and high speeds when turning.

OBS.1.1-008.01.EN

4.13 CLEANING



DANGER

Refer to the instructions for using cleaning detergents and preservatives.

When washing with detergents, wear suitable protective clothing and eye protection.



DANGER

When the mower is connected to the tractor, it is only possible to stay near the machine when:

the tractor engine is switched off and the PTO shaft is disengaged.

Thoroughly clean the mower from any material that is being processed every day after work. If you use a pressure washer, familiarize yourself with the principle of operation and recommendations for safe operation of this device.

Guidelines for the machine cleaning

Stop the tractor and the machine on a flat, level surface.

- Turn off the tractor engine and of the tractor the keys from the ignition.
- Secure the tractor with the parking brake and place safety wedges under the wheel of the machine axle.
- Secure the tractor against unauthorized persons.
- Remove crop residues from the machine surface;
- Clean and wash the mower with a strong stream of water and allow to dry in a dry and ventilated place.

The use of pressure washers increases the effectiveness of washing, but be careful when work. During washing, the nozzle of the cleaning aggregate must not be closer than 50 cm from the surface being cleaned.

The water temperature should not exceed 55°C.

Paint damage may occur when washing with excessive pressure.

Do not direct the water jet directly at the elements of the machine's system and equipment, i.e. control valve, brake cylinders, pneumatic, electric cylinders, lights, electrical connector, information and warning decals, nameplate, pipe connectors, lubrication points, etc. High water pressure may cause mechanical damage to these components.

- For cleaning and maintenance of plastic surfaces,



CAUTION

Clean any material that is being cut from the mower after each operation.

After cleaning, wait until the machine is dry and then lubricate all lubrication points as recommended. Wipe off excess grease or oil with a dry cloth.

During work, use appropriate, close-fitting protective clothing, gloves and the right tools.

to use clean water or specialized preparations intended for this purpose.

- Surfaces oily or greasy by grease should be cleaned with petrol or degreasing agents, and then washed with clean water and detergent. Follow the cleaning agent manufacturer's instructions.
- Washing and drying of the machine must take place at an ambient temperature above 0 °C.

In winter, frozen water can cause damage to the paint coat or machine components.

OBS.1.1-009.01.EN

4.14 DISCONNECTING OF THE MACHINE FROM THE CARRIER



DANGER

Before disconnecting the machine from the carrying vehicle, turn off the engine, engage the parking brake and secure the cabin against unauthorized access.

Exercise extreme caution when disconnecting the machine from the carrier.



DANGER

When detaching the machine, do not allow bystanders to stand in the vicinity due to the possibility of being crushed by the arms.



DANGER

Keep sufficient space around the tool and arms to avoid contact with buildings or overhead power lines.



DANGER

Before disconnecting the hydraulic system, reduce the pressure in the system.

Before disconnecting the mower from the carrier, the mower must be placed on a level, suitably hard surface in such a way that it can be connected again. In order to disconnect the mower from the carrier, perform the following actions:

- Place the machine in the parking position.
- Shut off the tractor engine, remove the ignition key, apply the parking brake.
- Chock the wheels.
- Open valve hydraulic hoses for the suspension.
- Start the tractor and raise the mower suspension as far as possible.
- Shut off the tractor engine, remove the ignition key, apply the parking brake.
- Remove the adjustment plates from the mid-plate suspension cylinder rods.
- Start the tractor and lower the mower suspension as far as possible.
- Shut off the tractor engine, remove the ignition key, apply the parking brake.
- Unfold the support foot
- Lower the support foot so that the machine can be safely detached from the carrier.
- Reduce residual pressure in the hydraulic system by moving the appropriate hydraulic circuit control lever on the carrier.
- Disconnect the hydraulic hose plugs from the carrier, secure with plugs and place them in a support on the machine frame.
- Disconnect the mower electrical arms plugs from the carrier (tractor).
- Disconnect the IDL from the PTO of the carrier.

- After disconnecting the PTO shaft, place it on the bracket.
- Secure the machine against unauthorized use with a safety device.

OBS.1.1-007.01.EN

4.15 STORAGE



IMPORTANT

While washing do not direct a strong water or steam jet at information and warning decals, bearings, hydraulic lines or electrical wires.

After finishing work, mower should be thoroughly cleaned and washed with water jet. Nozzle of pressure or steam washer should be kept at a distance of not less than 50 cm from cleaned surface.

After cleaning, inspect the whole machine, inspect technical condition of individual elements. Repair or replace any used or damaged components.

In the event of damage to the paint coat, clean rust and dust from damaged area, degrease and then paint with undercoat and after it is dry paint with surface coat paint retaining colour uniformity and even thickness of protective coating. Until the time of touch-up painting, the damaged place may be covered with a thin layer of grease or anticorrosion preparation.

If the machine will not be used for a long time, protect it against adverse weather conditions. The mower should be lubricated according to the instructions provided regardless of the date of the last lubrication. Protect against corrosion all mating components, such as pins or articulated joints. Cover them with a thin layer of grease.

The machine should be stored in a roofed building inaccessible for children and animals. The machine unhitched from the carrier vehicle should be placed on level, sufficiently hard surface in a way as to ensure that it is possible to hitch it again.

OBS.1.1-012.01.EN

CHAPTER 6

PERIODIC INSPECTIONS AND TECHNICAL SERVICE

PRONAR KPR700

6.1 GENERAL



CAUTION

It is forbidden to use a damaged machine.

Repairs during the warranty period may only be carried out by authorized service centres.

When using the mower, it is necessary to constantly check the technical condition and perform maintenance procedures that will allow the machine to be kept in good technical condition. It is mandatory to carry out all maintenance and adjustment operations specified by the manufacturer according to the prescribed schedule.

Repair of the during the warranty period may only be carried out by Authorized Sales and Service Points (APSiO). The machine's warranty inspection is only carried out by authorized service centres.

In the event of unauthorized repairs, changes to factory settings or activities that have not been considered as being possible by the machine operator (not described in this manual), the user loses the warranty.

For detailed information on the maintenance schedule, refer to the chapter entitled " *Maintenance and Inspection Schedule* ".

After the warranty expires, it is recommended that the inspections be carried out by specialized repair workshops.

Use appropriate protective clothing and equipment when working.

SER.1.1-001.01.EN

6.2 MAINTENANCE AND INSPECTION SCHEDULE

Table 6.1. Review categories

Category	Description	Responsible	Frequency
A	Daily review	Operator	Every day before first start-up or every 10 hours of continuous shift work.
A50	Maintenance	Operator	Inspection performed after the first 50 hours of work. A daily review should be carried out before performing this review.
B	Maintenance	Operator	The inspection is carried out periodically every 500 work hours of every month the machines works, whichever comes first. Each time before performing this review, a daily check must be carried out.
C	Maintenance	Operator	Inspection carried out periodically every 3 months. Each time before carrying out this inspection, carry out a daily inspection and inspection every one month of use of the machine.
D	Maintenance	Operator	Inspection carried out periodically every 6 months. Each time before carrying out this inspection, perform a daily inspection, inspection every 1 month of the machine use and inspection every 3 months.
E	Maintenance	Operator	Inspection carried out periodically every 12 months. Each time before carrying out this inspection, perform a daily inspection, inspection every 1 month of the machine use and inspection every 3 months.
F	Guarantee	APSiO ⁽¹⁾	Inspection carried out for a fee after the first 12 months of use of the machine, after reporting the owner.
G	Maintenance	Service ⁽²⁾	Inspection carried out every 4 years of machine use

(1) - Authorized Sales and Service Centre

(2) - post-warranty service

Table 6.2. Technical inspection schedule

Description of activities	A	A50	B	C	D	E	F
Correct attachment and wear of the cutting knives	•						
Technical condition of articulated shaft , guards and securing chains.	•						
Checking plugs and connection sockets	•						
Checking of the protective covers	•						
Checking of the machine before driving	•						
Measurement of air pressure, check tires and wheels	•						
Oil level in the drive train gears	•						
Efficiency of the mower's lighting and signaling system	•						
Checking of the looseness of the axle bearings					•		
Checking of the tightness of the running wheels		•	•				
Hydraulic system checking		•				•	
The gearbox oil replacement		•				•	
Wear condition of cutting knife bushings						•	
Lubrication	See table: <i>Lubrication schedule</i>						
Checking screw connections	See table: <i>Tightening schedule for important bolted connections</i>						
Replacement of hydraulic hoses	Every 4 years						

6.3 CHECKING PLUGS AND CONNECTION SOCKETS



DANGER

The hydraulic system of the machine and tractor is under high pressure.

It is forbidden to use a damaged machine.

A damaged body of the hydraulic or pneumatic hose connector or socket qualifies them for replacement. In the event of damage to the cover or gasket, replace these elements with new, functional ones. Contact of pneumatic connection seals with oils, grease, gasoline etc. may damage them and accelerate the aging process.

If the machine is disconnected from the tractor, connections should be protected with covers placed in their designated sockets. Before the winter period, it is recommended to preserve the seal with preparations

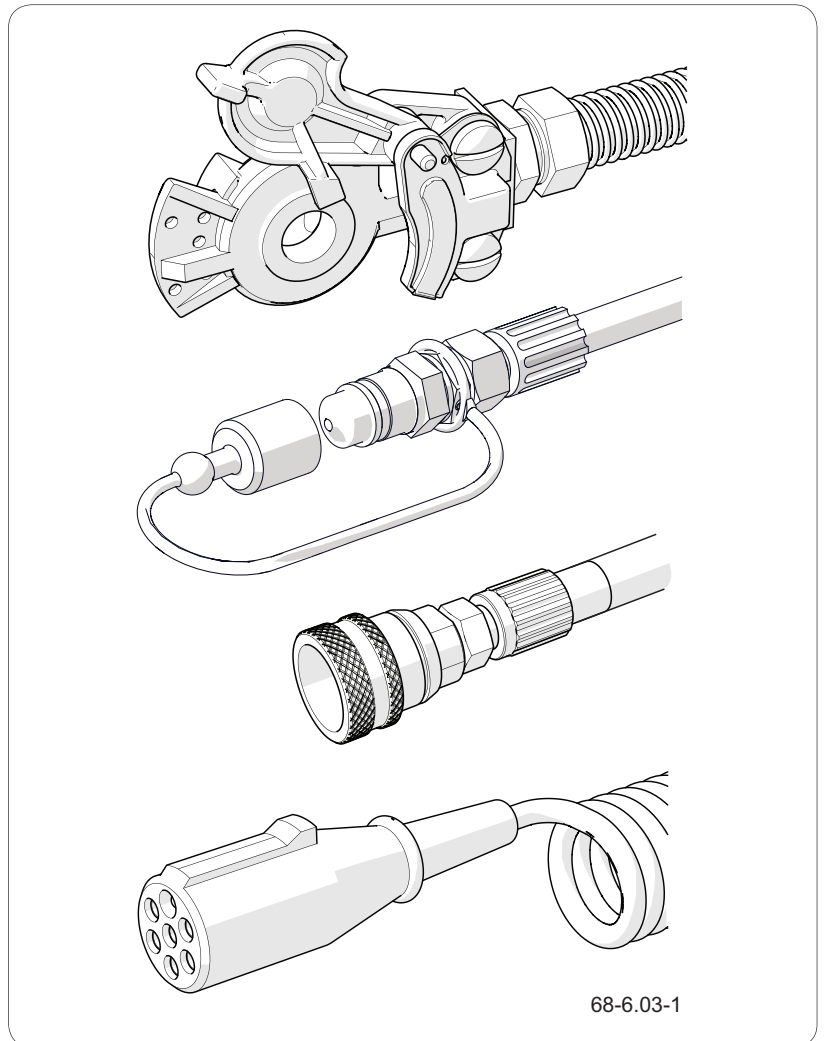

Figure 6.1 Examples of connections

intended for this purpose (e.g. silicone lubricants for rubber elements).

Each time before connecting the machine, check the technical condition and degree of cleanliness of connections and sockets on the agricultural tractor. If necessary clean or repair tractor sockets.

SER.1.1-014.01.EN

6.4 MEASUREMENT OF AIR PRESSURE, CHECK TIRES AND WHEELS



ADVICE

In the event of intensive use of the machine, we recommend more frequent pressure checks



CAUTION

Using the machine in which tires are not properly inflated may lead to permanent damage to the tire as a result of delamination of the material.

Incorrect tire pressure also causes faster tire wear.

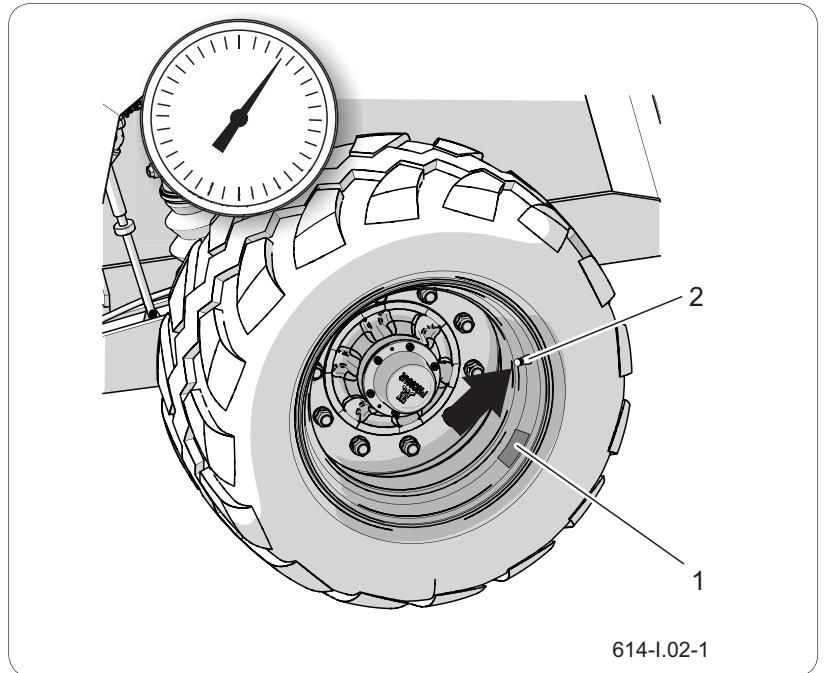

Figure 6.2 Machine wheel
(1) sticker (2) valve

Checking should be carried out before driving, when the tires are not warm, or after a long standstill of the machine.

The scope of activities

1. Connect the pressure gauge to the valve.
2. Check air pressure.
3. If necessary, inflate the wheel to the required pressure.
4. The required air pressure is described on a decal (1) located on the wheel rim.
5. Check tread depth.
6. Inspect the tire sidewall.
7. Inspect the tire for defects, cuts, deformations, bumps indicating mechanical damage to the tire.

8. Check that the tire is correctly positioned on the rim.

9. Check the tire age.

When checking the pressure, pay attention to the technical condition of the rims and tires. In the event of mechanical damage, consult your nearest tire service centre and ensure that your tire defect is eligible for replacement. Rims should be checked for deformation, material cracks, weld cracks, corrosion, especially around welds and in the place contact with the tire.

SER.1.1-004.01.EN

6.5 HYDRAULIC SYSTEM CHECKING



CAUTION

It is forbidden to use the machine with inefficient hydraulic system.

Checking of the hydraulic system for leaks

1. Connect the machine to the tractor.
2. Connect all the hoses of the hydraulic system according to the recommendations of the "User's Manual".
3. Clean hose connections, hydraulic cylinders and couplings.
4. Activate all hydraulic systems in turn, extending and retracting the piston rods of the cylinders.
5. Repeat all operations 3- 4 times.
6. Leave the hydraulic cylinders fully extended.
7. Check the all hydraulic circuits for leaks.
8. After completing the inspection, put all cylinders to the rest position.

In the event of oiling on the hydraulic cylinder body, the nature of the leakage must be checked.

When the cylinder is fully extended, Check the the seal locations. Small leaks with signs of "sweating" are acceptable. If you notice a drip-type leak, do not use the machine until the problem has been corrected. If visible moisture appears on the cable connectors tighten the the connector with a specified torque and carry out out the test again. If the problem persists Dimensions the leaking element.

Inspection of the technical condition of hydraulic connectors

Hydraulic couplings for connecting to the tractor must be technically sound and kept clean. Each time before connecting, make sure that the sockets in the tractor are maintained in good condition. The tractor's and mower's hydraulic systems are sensitive to the

presence of solid impurities that can cause damage to precise components of the installation (scratch the surface of cylinders, etc.)

SER.1.1-005.01.EN

6.6 REPLACEMENT OF HYDRAULIC HOSES



Rubber hydraulic hoses should be replaced every 4 years regardless of their technical condition. This operation should be entrusted to specialized workshops.

SER.3.8-020.01.EN

6.7 TIGHTENING TORQUES FOR SCREW CONNECTIONS



During maintenance and repair work, apply appropriate tightening torques to screw connections, unless other tightening parameters are given. Recommended tightening torques for the most commonly used bolted connections are shown in the Table “*Tightening torques for screw connections*”. The given values apply to non-lubricated steel bolts.

Hydraulic lines and other hydraulic components with rubber seals should be tightened with torque according to the Table “*Tightening torques of hydraulic elements*”.

Check the tightness using a torque wrench. During daily inspection of the machine pay attention to loose connections and tighten the connector if necessary. Replace the lost elements with new ones.

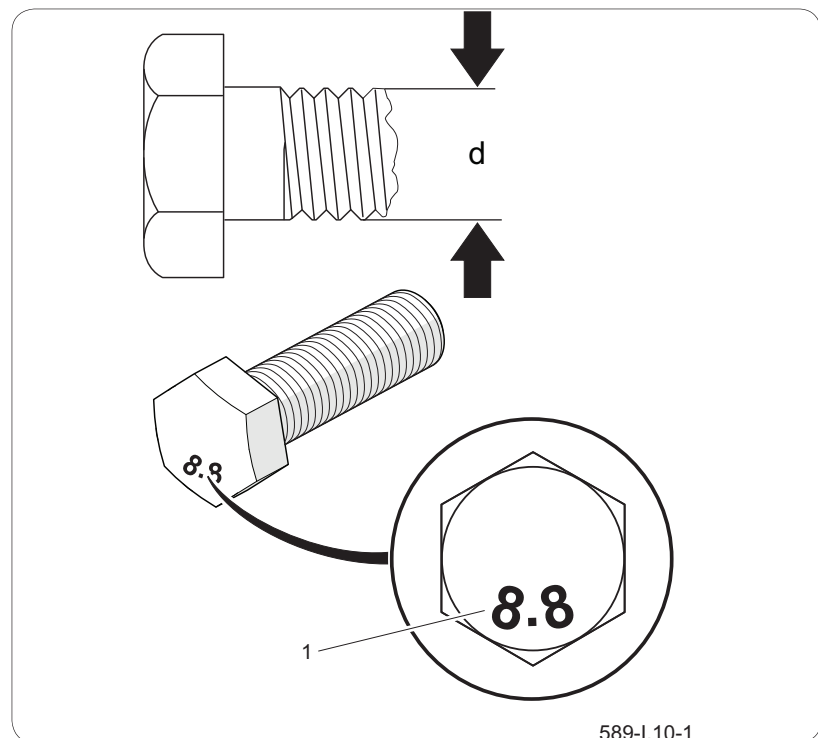

Figure 6.3 Screw with metric thread
(1) strength class, (d) thread diameter

Table 6.3. Tightening torques for screw connections

Metric		
	8.8 ^(*)	10.9 ^(*)
M8	25	36
M10	49	72
M12	85	125
M14	135	200
M16	210	310
M20	425	610
M24	730	1,050
M27	1,150	1,650
M30	1,450	2,100

(*) - strength class according to DIN ISO 898

Table 6.4. Tightening torques of hydraulic elements

Thread of nuts	Wire diameter DN (inch)	Tightening torques [Nm]
M10x1 M12x1.5 M14x1.5	6 (1/4")	30÷ 50
M16x1.5 M18x1.5	8 (5/16")	30÷ 50
M18x1.5 M20x1.5 M22x1.5	10 (3/8")	50÷ 70
M22x1 M24x1.5 M26x1.5	13 (1/2")	50÷ 70
M26x1.5 M27x1.5 M27x2	16 (5/8")	70÷ 100
M30x1.5 M30x2 M33x1.5	20 (3/4")	70÷ 100
M38x1.5 M36x2	25 (1")	100÷ 150
M45x1.5	32 (1.1/4")	150÷ 200

SER.3.G-011.01.EN

6.8 WHEEL MAINTENANCE



Remove wheel

- Place chocks under the wheel that will not be dismantled.
- Ensure that machine is immobilised when wheel is being removed.
- Loosen wheel nuts according to the sequence shown in figure (6.4).
- Place lifting jack and lift rotary rake.
- Dismount wheel.

Install wheel

- Clean half axle pins and nuts of dirt contamination.
- Do not grease thread of nuts and pins.
- Check condition of pins and nuts, if necessary replace them.
- Place wheel on hub, tighten nuts so that wheel rim tightly fits the hub.
- Lower the machine, tighten nuts according to recommended torque and given sequence.



IMPORTANT

Wheel nuts must not be tightened with impact wrench because of danger of exceeding permissible tightening torque, the consequence of which may be breaking the connection thread or breaking off the hub pin.

TIP

Wheel nuts should be tightened using the torque of 270 Nm – M18x1.5 nuts.

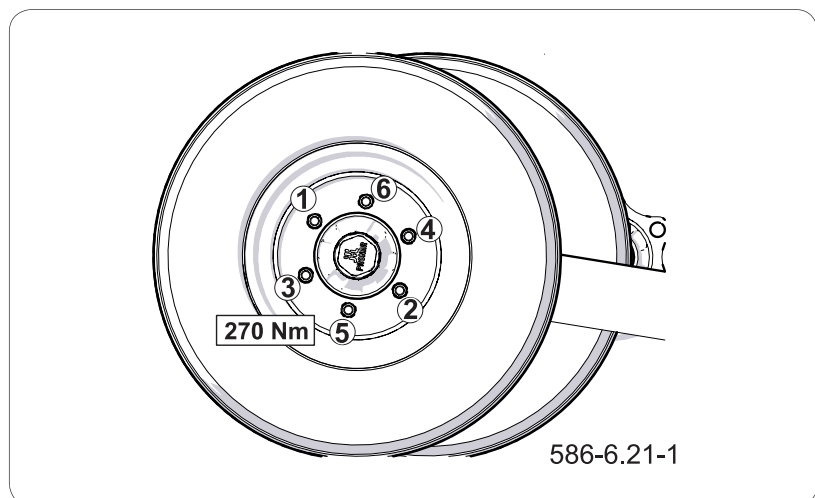

Figure 6.4 Sequence of nut tightening

Tightening nuts

Nuts should be tightened gradually diagonally, (in several stages, until obtaining the required tightening torque) using a torque spanner.

Check tightening of half axle wheel nuts:

- after the first use of the trailer,
- after first day of work,
- at regular intervals (50 h).

Czynności kontrolne należy powtórzyć jeżeli koło było demontowane.

The inspection should be repeated individually if a wheel has been removed from the wheel axle.

The greatest precision is achieved using a torque spanner. Before commencing work, ensure that correct tightening torque value is set.

Check air pressure in tyres, technical condition of tyres and steel rims

TIP

Tyre pressure values are specified in information decal, placed on wheel.



DANGER

Damaged tyres or wheels may be the cause of a serious accident.

Tyre pressure should be checked each time after changing spare wheel and not less than every month.

In the event of intensive use, air pressure in tyres should be checked more frequently. Check tyres before you drive off when tyres are not warm, or after the machine has been parked for an extended period.

While checking pressure pay attention to technical condition of wheels and tyres.

Look carefully at tyre sides and check the condition of tread.

In case of mechanical damage consult the nearest tyre service and check whether the tyre defect requires tyre replacement.

Wheels should be inspected with regard to distortion, breaking of material, breaking of welds, corrosion, especially in the area of welds and contact with tyre.

Proper technical condition and appropriate maintenance of wheels significantly extends the life of these components and ensures appropriate level of safety to machine users.

Check air pressure in tyres and visual inspection of steel wheels:

- at regular intervals (100 h).
- if needed.

SER.1.1-006.01.EN

6.9 HALF AXLE MAINTENANCE

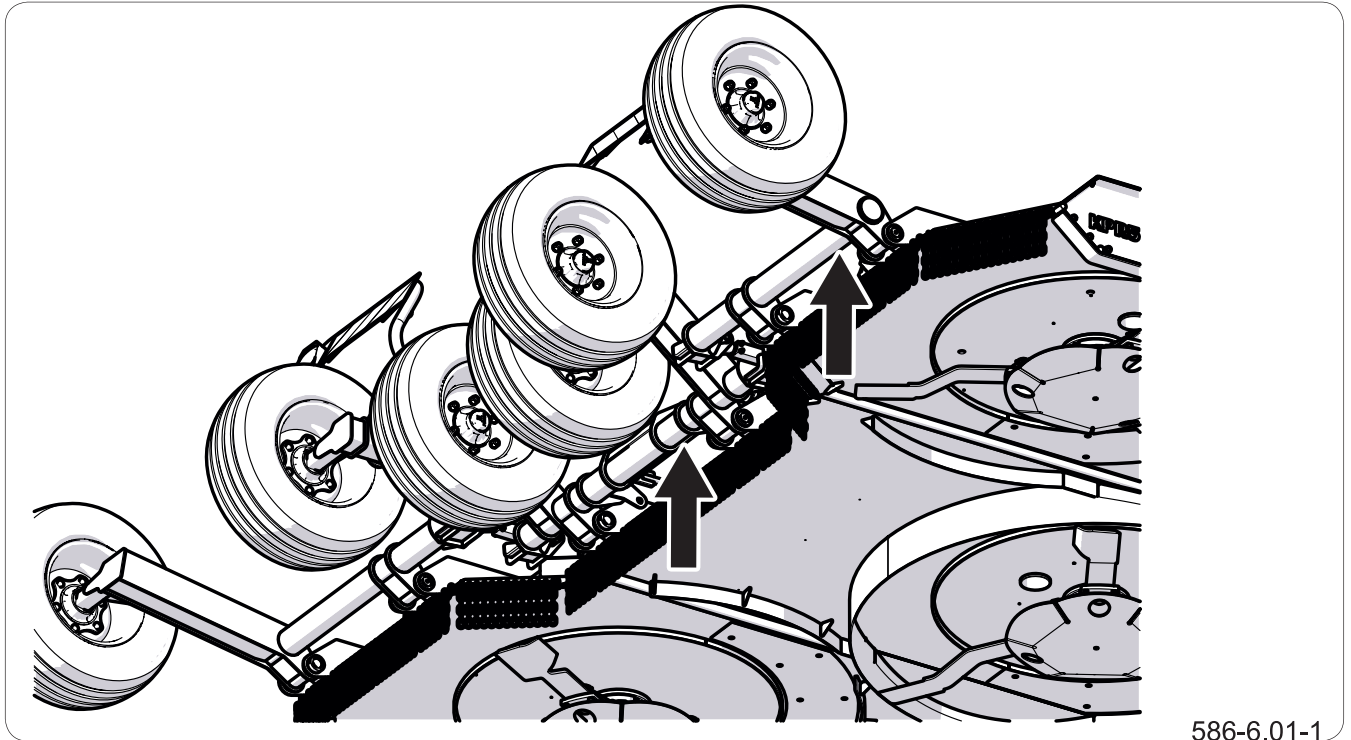

Figure 6.5 Lifting jack support point



IMPORTANT

Before commencing work, the user must read the instructions for lifting jack and adhere to the manufacturer's instructions.

TIP

If hub cover is damaged or missing, contamination and dampness enter the hub, which causes significantly faster wear of bearings and hub seals.

Bearing life is dependent on machine working conditions, loading, ground speed and lubrication conditions.

Work connected with the repair, change or regeneration of half axle components should be entrusted to specialist establishments, having the appropriate technology and qualifications for this type of work.

The responsibilities of the user are limited to:

- inspection and adjustment of loose play of half axle bearings,
- Install and remove wheel, inspect wheel nut tightness.
- check air pressure, evaluating technical condition of wheels and tyres.

Procedures connected with:

- changing grease in half axle bearings,
- changing bearings, hub seals,

may be performed by specialist workshops.

TIP

Check wheel half axle bearings for looseness:

- after the first month of use,
- every 6 months of use.

Check wheel half axle bearings for looseness



Figure 6.6 Check wheel half axle bearings looseness



DANGER

The lifting jack must be stably supported by the ground and so must the half axle.

Ensure that the machine is immobilised during inspection of half axle bearing slackness.

Preparation procedures

- Hitch machine to tractor, immobilise tractor with parking brake
- Park tractor and machine on hard level ground.
- Tractor must be placed to drive forward.
- Place the wheel chocks under the machine's wheel opposite to the lifted wheel. Ensure that machine will not move during inspection.
- Raise the wheel (opposite to the side where chocks are placed). Lifting jack should be positioned in the place indicated by the arrow in figure (5.1). Lifting jack must be suitable for machine weight.

TIP

The bearing clearance is easier to check and adjust if the wheel is removed.

Check wheel half axle bearings looseness

- Turning the wheel slowly in both directions check that movement is smooth and that the wheel rotates without excessive resistance.
- Turn the wheel so that it rotates very quickly, check that the bearing does not make any unusual sounds.
- Moving the wheel try to detect slackness. You may use a lever placed under the wheel supporting the other end of the lever on the floor.

- Repeat the procedure for the other wheel, remembering that the lifting jack must be on the side opposite to the chocks.

If slackness is felt, adjust bearings. Unusual noise made by the bearing may be a symptom of excessive wear, dirt or damage. In such an event the bearing, together with sealing ring, should be replaced with new parts, or cleaned and greased again. During inspection of bearings ensure that possibly detected looseness comes from the bearing and not from the suspension system.

Check condition of hub cover, if necessary replace it with a new cover. Only inspect bearings for looseness, when the machine is hitched to a tractor.

Adjust slackness of half-axle shaft bearings

Prepare tractor and machine for adjustment procedures according to description provided in the section *PREPARATION PROCEDURE*.

Adjusting looseness of half axle bearing

- Take off hub cover (1) – figure (6.1).
- take out split cotter pin (2) securing castellated nut (3)

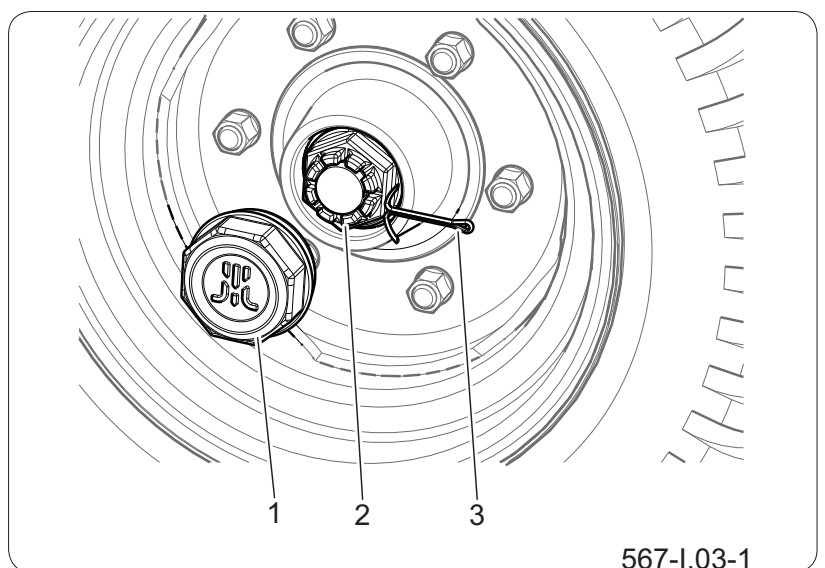

Figure 6.7 Adjustment of road wheel axle bearings
 (1) hub cover (2) castellated nut
 (3) - securing cotter pin

- Tighten castellated nut in order to eliminate slackness. Wheel should rotate with insignificant resistance.
- Undo nut (not less than 1/3 rotation) to align the nearest thread groove with the opening in wheel half axle pin. Wheel should rotate without excessive resistance.
- The nut must not be excessively tightened. Do not apply excessive pressure because working conditions of the bearings may deteriorate.
- Secure castellated nut with cotter pin and mount the hub cap.
- Delicately tap the hub cap with rubber or wooden mallet.

The wheel should turn smoothly without jamming and detectable resistance. Only adjust bearings, when the machine is hitched to a tractor.

SER.1.1-009.02.EN

6.10 DRIVE TRANSMISSION SYSTEM MAINTENANCE



DANGER

If the machine is hitched to the carrier, disengage the PTO, remove the key from the ignition and immobilize the vehicle with the parking brake before you inspect or adjust the transmission system.



DANGER

Do not touch the telescopic shafts after stopping the machine!

The shafts are equipped with friction clutches, which can become hot during slipping.

Drive transmission system maintenance (Figure: *Inspect and replace oil in the gearbox*) involves:

- periodically inspect and change oil in bevel gears and divider gears,
- lubricate telescopic shafts according to the schedule (Table: *Technical inspection schedule*).

The correct oil level in angle transmissions (Drawing: *Checking and changing oil in angle transmissions*) should be on the bar indicator (2) in the space from its end to the notch. In the separating transmission, the oil level should be between the notches of the indicator (2) (Drawing: *Checking and changing the oil in the separating transmission*). Perform oil change right after work, when the transmission is warmed up and possible impurities are mixed with oil.

Add oil through the filler opening in the gear top cover.

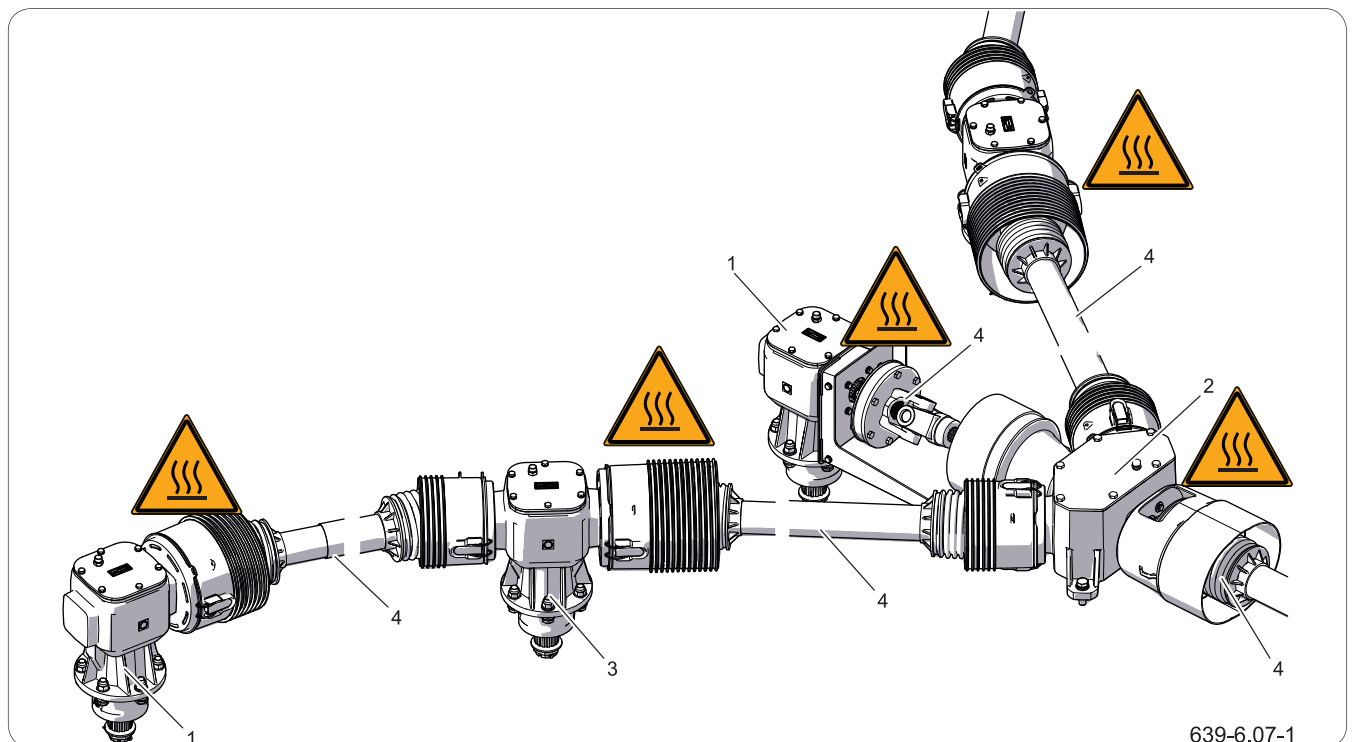

Figure 6.8 Inspect and replace oil in the gearbox

(1) bevel gear

(2) divider gearbox

(3) telescopic shafts



IMPORTANT

Repairs of bevel gear during warranty period may only be performed at authorised mechanical workshops.

TIP

Fill gears with SAE.90EP (80W90 GL-5) oil - 2.7 litres each.

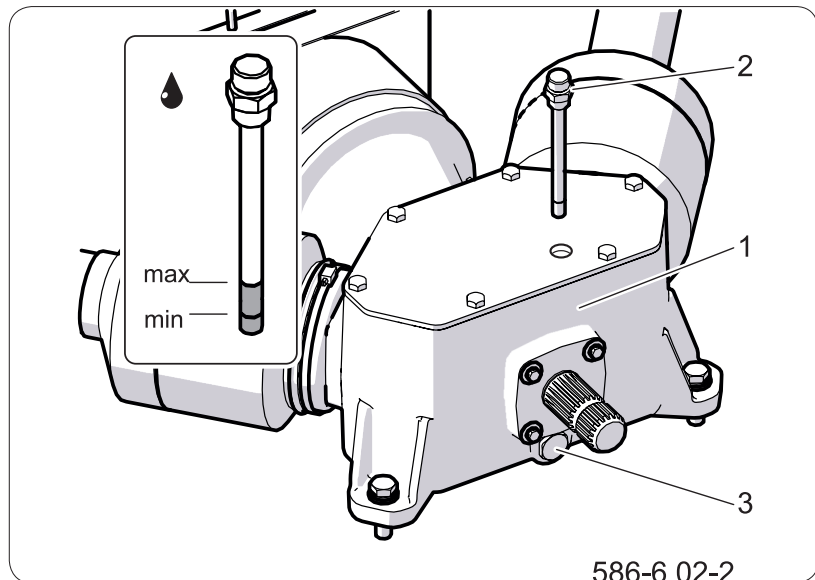

Figure 6.9 Check and change of oil in divider gear
 (1) gear body (2) plug with dipstick;
 (3) oil drain

If a leak is noticed, carefully inspect seals and check oil level. Operation of the transmission with insufficient oil level or without oil may cause permanent damage to the transmission mechanisms.

Only add or change oil when the machine is disconnected from the tractor, and resting on supports.

level the machine The wheels should be secured with chocks against possible rolling.

To change oil in divider gearbox (Figure: *Check and change of oil in divider gear*):

- remove the articulated telescopic shaft on the tractor end.
- remove the PTO shaft guard provided on the gear housing,
- unscrew the upper plug 2
- unscrew the plug (3) in the bottom part of the body under the PTO.
- Drain oil to an appropriate receptacle.
- tighten the plug, add new oil through the opening in the cylinder top cover.

To change oil in bevel gearbox (Figure: *Check oil level and change oil in bevel gears*):

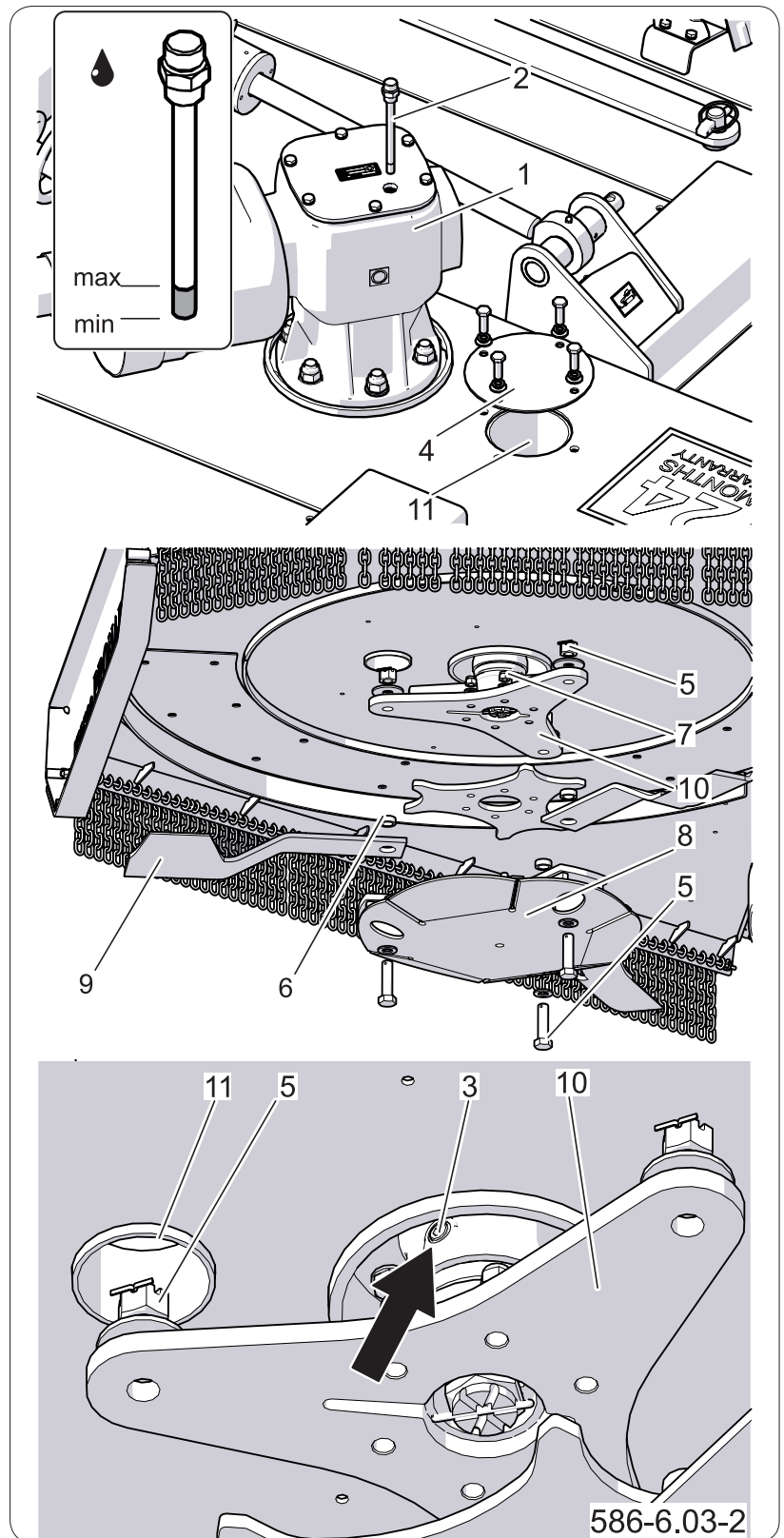

Figure 6.10 Check oil level and change oil in bevel gears
 (1) gear body (2) plug with dipstick;
 (3) oil drain (4) inspection opening cover
 (5) blade mounting nut (7) cutting unit mounting nut
 (8) cutting unit guard (9) cutting blades
 (10) cutting unit bracket (11) inspection opening

- unscrew the inspection hole cover (4),
- through the inspection hole (11) loosen the fastening (5) of the cutting blades (9)
- unscrew the top filler plug (2),
- remove the cutting blades (9),
- unscrew the fastener (7) of the unit guard (8),
- use an Allen key to unscrew the oil drain plug (3)
- Drain oil to an appropriate receptacle.
- tighten drain plug (3).
- assemble the cutting unit,
- add oil to the gear.

SER.1.1-008.23.EN

6.11 OPERATION OF THE CUTTING HEAD



ADVICE

Check the cutting edge of the knives at least every two days of use of the machine.



DANGER

The cutting knives are very sharp, so be careful when installing or removing them.

Replacement of the cutting knives

Depending on how the machine is used, the knives need to be sharpened or replaced after a certain period of use.

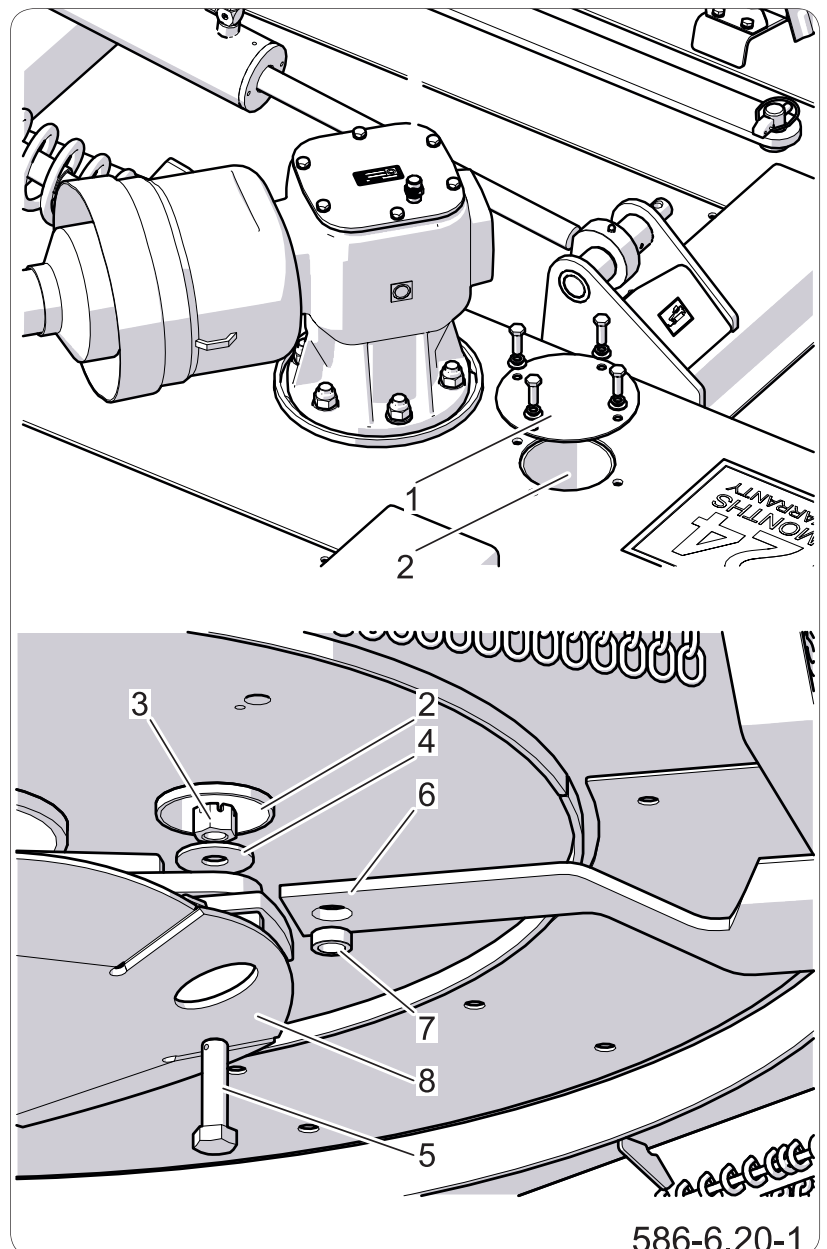

Figure 6.11 Replacement of the cutting knives

(1) - cover for inspection hole, (2) - inspection hole;

(3) - nut, (4) - washer,

(5) - bolt, (6) - knife,

(7) - sleeve, (8) - cylinder head cover,



CAUTION

When installing the knives, pay attention to the direction of rotation of the cutterhead.



CAUTION

Replace knives with sets of bolts and knife bushings.



DANGER

Moving the head on the left side of the mower can cause the knife to be overweighed on the right side and vice versa. The knife is heavy and can hit with great force.

The service life of the knives is significantly reduced when working on uneven terrain with stones.

The knife, bolt, bushing and nut are worn during operation, all of which must be replaced at the same time.

To replace the cutting knives (Figure *Replacing of the cutting knives*):

- Unscrew the inspection hole cover (1),
- Remove the cotter pins from the castle nuts (3),
- Remove the nuts from the bolts (5) holding the knives (6).
- Remove the knives from the seats, remove the bushings (7) from the knife hole,
- Install in reverse order, replacing the bushings, bolts and nuts with new ones.

Tighten the screw connection to the specified torque.

When working on the cutterhead on folded wings, watch out for the knives. Moving the knife, removing the foot, rotating the head or any of the telescoping shafts can cause the knives to move rapidly in the head.

Table 6.1. List of wear parts for three-knife head

Item	Name	Part No.	Number of pieces
1	Right knife 63-SPH-02-R	303-890-000249	6 pieces
	Right knife Hardox	407-001-005816	6 pieces
2	Left knife 63-SPH02-L	303-890-000250	3 pieces
	Left knife 63-SPH02-L	407-001-005815	3 pieces
3	Knife bushing	407-005-004379	9 pieces
4	Knife bolt	407-005-004378	9 pieces
5	Ring nut	324-200-000704	9 pieces

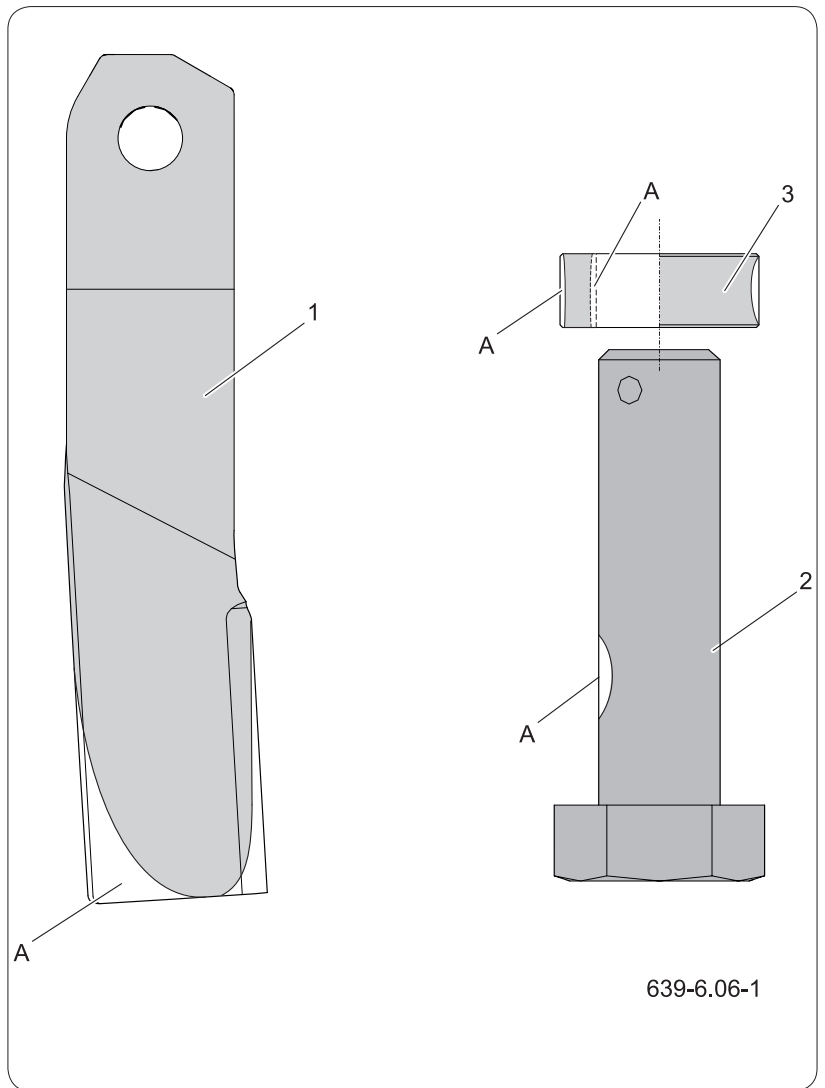

Figure 6.12 Potential wear points for head components
 (1) - knife, (2) - knife mounting bolt;
 (3) - knife bushing, (a) - places of wear, losses,

SER.1.1-007.12.EN

6.12 SMAROWANIE

**WSKAZÓWKA**

Częstotliwość smarowania (tabela Harmonogram smarowania maszyny):

D - dzień roboczy (8 godzin pracy maszyny),

M - miesiąc

- Smarowanie maszyny wykonuj przy pomocy smarownicy ręcznej lub nożnej, wypełnionej zalecanym środkiem smarnym. Przed rozpoczęciem pracy usuń stary smar oraz inne zanieczyszczenia. Po zakończeniu pracy wytrzyj nadmiar smaru.
- Części, które powinny być smarowane przy użyciu oleju maszynowego przetrzyj suchą i czystą szmatką. Olej nanoś na powierzchnię pędzelkiem lub oliwiarką. Nadmiar oleju wytrzyj.
- Wymianę smaru w łożyskach piast osi jezdnych zleć wyspecjalizowanemu punktowi serwisowemu, wyposażonemu w odpowiednie narzędzia. Zdemontuj całą piastę, wyjmij łożyska oraz poszczególne pierścienie uszczelniające. Po dokładnym umyciu oraz przeprowadzeniu oględzin zamontuj nasmarowane elementy. W razie konieczności łożyska oraz uszczelnienia wymień na nowe.
- Puste opakowania po smarze lub oleju utylizuj zgodnie z zaleceniami producenta środka smarnego.

Table 6.5. Środki smarne

LP.	Symbol	Opis
1	A	smar stały maszynowy ogólnego przeznaczenia (litowy, wapniowy),
2	B	smar stały do elementów mocno obciążonych z dodatkiem MoS ₂ lub grafitu
3	C	preparat antykorozyjny w aerozolu
4	D	olej maszynowy zwykły, smar silikonowy w aerozolu
5	E	olej przekładniowy SAE.90EP (80W90 GL-5)

Table 6.6. Harmonogram smarowania maszyny

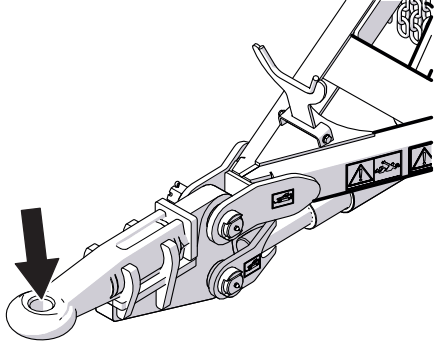
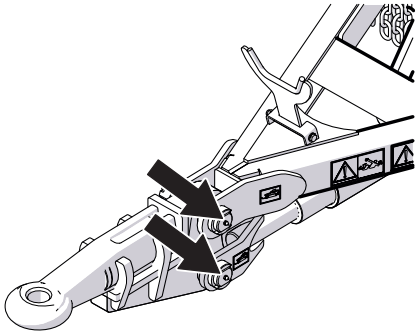
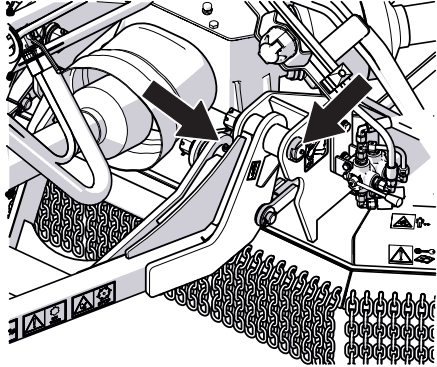
Nazwa	Ilość punktów	Rodzaj smaru	Częstotliwość	
Oko ciągną dyszla	1	B	10D	 <p data-bbox="1257 927 1414 958">586-6.06-1</p>
Sworznie zaczepu (przód)	2	A	15D	 <p data-bbox="1257 1386 1406 1417">586-6.07-1</p>
Sworznie zaczepu (tył)	4	A	15D	 <p data-bbox="1267 1839 1414 1870">586-6.08-1</p>

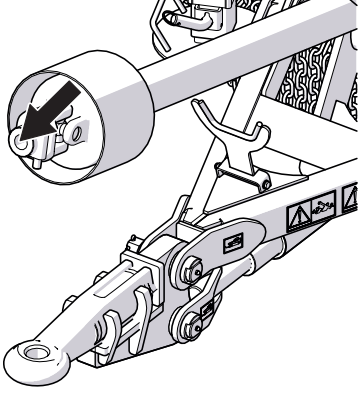
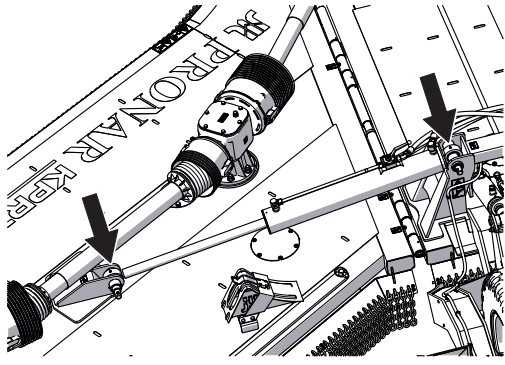
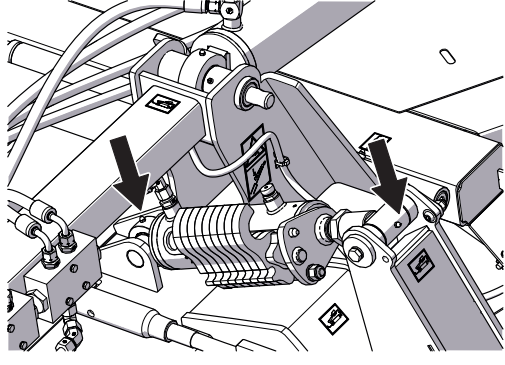
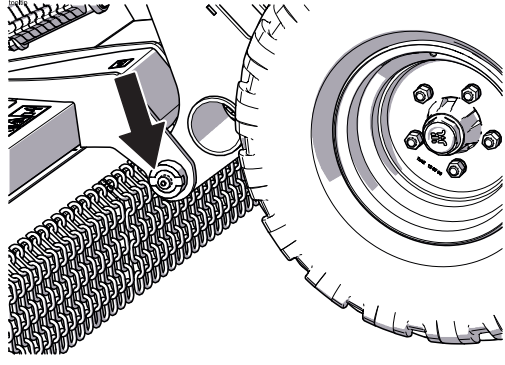
<p>Wał przegubowo teleskopowy (gniazdo)</p>	<p>1</p>	<p>B</p>	<p>15D</p>	 <p>586-6.09-1</p>
<p>Sworznie siłowników skrzydeł</p>	<p>4</p>	<p>A</p>	<p>15D</p>	 <p>639-6.08-1</p>
<p>Sworznie siłownika zawieszania</p>	<p>8</p>	<p>A</p>	<p>15D</p>	 <p>639-6.09-1</p>
<p>Sworzeń zawieszania skrzydła</p>	<p>2</p>	<p>B</p>	<p>5D</p>	 <p>639-6.10-1</p>

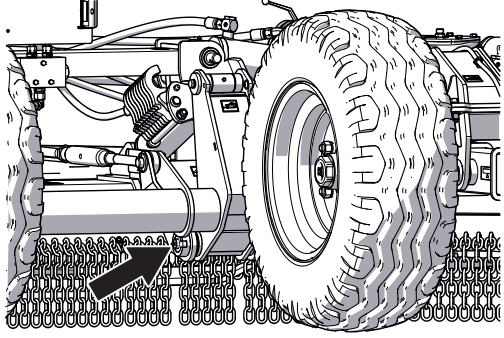
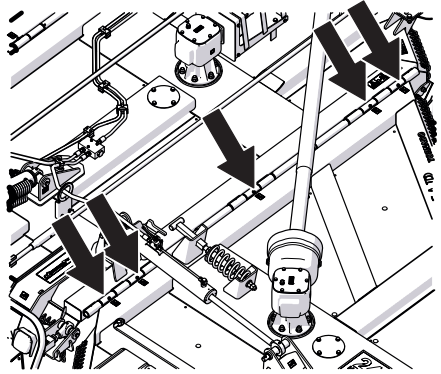
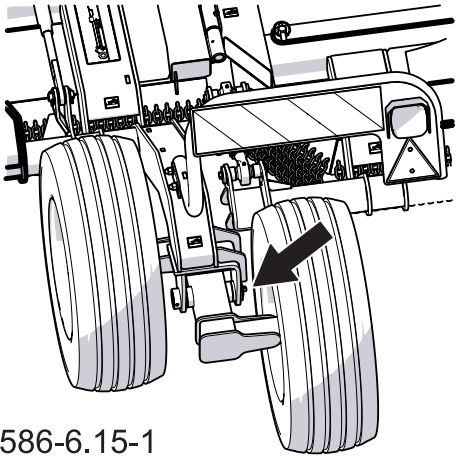
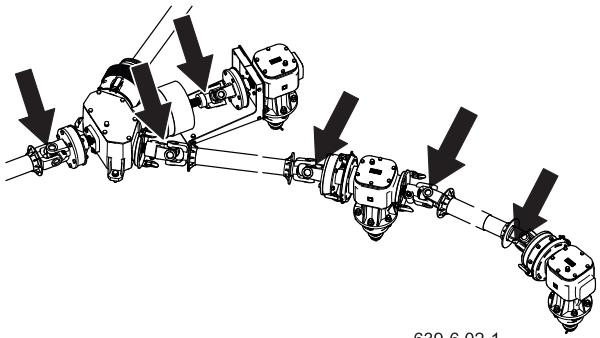
<p>Sworzeń zawieszenia płyty centralnej</p>	<p>2</p>	<p>B</p>	<p>5D</p>	 <p>639-6.11-1</p>
<p>Zawias skrzydeł</p>	<p>10</p>	<p>A</p>	<p>15D</p>	 <p>586-l.13.1</p>
<p>Sworzeń wahacza</p>	<p>4</p>	<p>B</p>	<p>5D</p>	 <p>586-6.15-1</p>
<p>Przeguby wałów *</p>	<p>10</p>	<p>B</p>	<p>2D</p>	 <p>639-6.02-1</p>

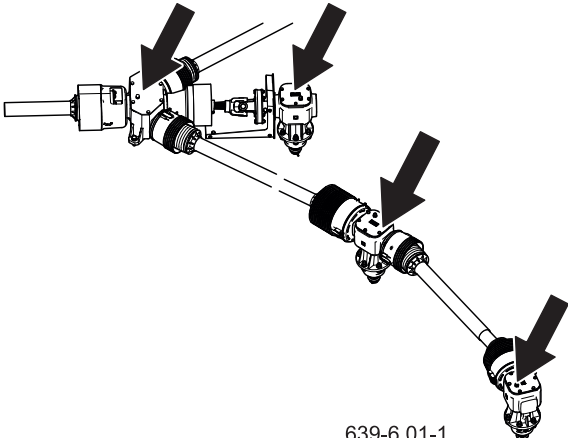
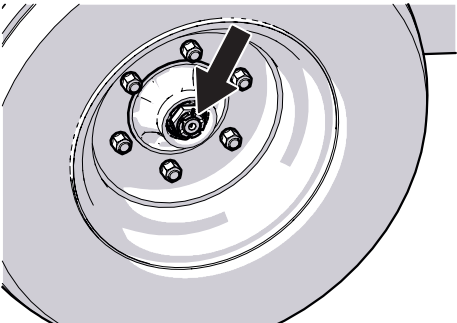
<p>Przekładnia kątowna przekładnia rozdzielająca</p>	<p>6</p>	<p>E</p>	<p>12M</p>	 <p>639-6.01-1</p>
<p>Łożyska piasty (po 2 sztuki w każdej piaście)</p>	<p>12</p>	<p>A</p>	<p>12M</p>	 <p>586-6.18-1</p>

* - Szczegółowe informacje na temat obsługi i konserwacji znajdują się w instrukcji obsługi producenta wału.

SER.1.1-010.01.PL

6.13 ELECTRICAL SYSTEM SERVICE AND WARNING ELEMENTS

Works related to the repair, replacement or regeneration of electrical installation components should be



CAUTION

Driving with defective lighting installations is prohibited. Damaged lamps should be replaced immediately before driving off. Lost or damaged reflectors should be replaced with new ones.

Before travelling, make sure that all lamps and reflectors are clean.

entrusted to specialized workshops that have appropriate technologies and qualifications to perform this type of work.

Your duties include only technical inspection of the electrical installation and reflectors.

The scope of activities

1. Connect the machine to the tractor with a suitable connection lead.
2. Make sure the connection cable is OK. Check the tractor connection socket on the machine.
3. Check the completeness, technical condition and correct functioning of the machine lighting.
4. Check the the wiring harness for damage (rubbed insulation, wire break, etc.). Check the completeness of lamps and all reflectors.
5. Check the mounting of the SMV triangular plate and its bracket.
6. Before travelling on a public road, make sure that the tractor has a reflective warning triangle.

SER.1.1-011.01.EN

6.14 CONSUMABLES



6.14.1 Hydraulic oil

ADVICE

In the hydraulic system of the machine, Agrol U Lotos oil was used.

It is absolutely necessary to observe that the oil in the machine's hydraulic system and the tractor's hydraulic system is of the same type. If different types of oil are used, make sure that both hydraulic means can be mixed together. The use of different types of oil may cause damage to the machine or agricultural tractor. The new machine is filled with Agrol U Lotos hydraulic oil.

If you need to change the hydraulic oil for another, read the oil manufacturer's instructions carefully. If he recommends flushing the system with an appropriate preparation, follow these recommendations. It ensured that the chemicals used for this purpose do not act aggressively on the materials of the hydraulic system. During normal operation of the machine, it is not necessary to change the hydraulic oil, however, if necessary, this operation should be entrusted to specialist service centres.

Due to its composition, the oil used is not classified as a dangerous substance, however, long-term action on the skin or eyes may cause irritation. In the event of contact of oil with skin wash the area of contact

Table 6.7. Characteristics of Agrol U Lotos oil

Item	Name	Unit	
1	Kinematic viscosity at 100°C	-	10.0-11.5
2	Viscosity index, min		>95
3	Pour point, max	°C	<-24
4	Base number mgKOH/g	-	9.9
5	Flash-point	°C	>230

**DANGER**

Do not use water to extinguish a fire of oil!

with water and soap. Do not use organic solvents (petrol, kerosene). Dirty clothing should be removed to prevent oil from getting on your skin. If the oil gets into your eyes, flush them with plenty of water and in case of irritation contact your doctor.

Hydraulic oil under normal conditions is not harmful to the respiratory tract. There is only a risk when the oil is sprayed strongly (oil mist) or in the event of a fire where poisonous compounds may be released. In the event of fire, the oil must be extinguished with carbon dioxide, foam or extinguishing steam

6.14.2 Lubricants

ADVICE

Lubrication frequency (Table Machine lubrication schedule)

For heavily loaded parts, it is recommended to use lithium grease with the addition of molybdenum disulphide (MOS₂) or graphite. For less loaded components, it is recommended to use general-purpose machine greases that contain anti-corrosive additives and are highly resistant to water washout. Similar properties should be characteristic of aerosol preparations (silicone lubricants, anti-corrosive lubricants). Before using lubricants, read the information leaflet for the selected product. Particularly important are safety rules and how to handle a given lubricant and how to dispose of waste (used containers, contaminated rags, etc.). The information leaflet (product card) store together with the grease.

SER.1.1-015.01.EN

6.15 TIRES

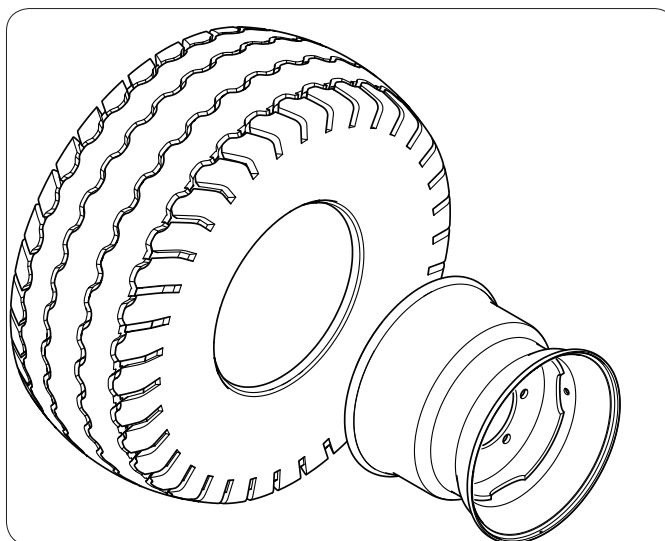

Table 6.8. Machine tires - carrier plate

Item	Tire size	Wheel size	Tire pressure
1	10,0/75-15,3 10PR IM18 TL TVS 123A8	9x15.3 (153.09.70)	490 kPa
2	10,0/75-15,3 10PR IM117 TL TVS 128A6/123A8	9x15.3 (153.09.70)	475 kPa
3	10,0/75-15,3 10PRAW909 TL BKT 126A8	9x15.3 (153.09.70)	520 kPa
5	10.0/75-15.3 10PR IM04 TL Mitas 122A8	9x15.3 (153.09.70)	400 kPa
6	10.0/75-15.3 10PR AW TL STARCO 123A8	9x15.3 (153.09.70)	390 kPa
7	10.0/75-15.3 10PR Deli Tyre 123A8	9x15.3 (153.09.70)	390 kPa

Table 6.9. Machine tires - arms

Item	Tire size	Wheel size	Tire pressure
1	10.0/80-12 TVS IM-117 10PR TL 120A6/117A8	7x12	390kPa

SER.1.1-013.01.EN

6.16 FAULTS AND HOW TO REMOVE THEM

Table 6.10. Faults and how to remove them

Problem	Possible cause	Solution
Excessive vibration	Inspect the transmission bolts.	Tighten if loose.
	Inspect loose cutterhead and knife nuts	Tighten if loose.
	Check that the output shaft is not bent. Caution: If the shaft is bent, oil will leak from the lower seal.	Replace the shaft if it is bent.
	Check that the blades rotate freely.	Loosen the blade retaining screw.
	Check for even wear on each blade tip. Have the blades been changed at the same time?	Weigh the blades. The weight difference of each knife in the unit should be within 20g. Always replace all blades in the assembly
	Broken blade.	Replace all blades in the head.
	Knife carrier bent (cutterhead).	Replace the media.
	Cutterhead hub is not seated correctly on shaft	Remove hub, inspect splined shaft, clean and replace.
	A new blade or bolts have been fitted	Replace the blades or bolts in the kits
Transmission overheating	Low oil level.	Fill to level.
	Incorrect oil type.	Replace on SAE.90EP (80W90 GL-5)
	Excessive accumulation of material (plant stalks) around the bevel gearbox	Remove any accumulated material.
	Bearing(s) incorrectly set	Contact your dealer.
Transmission leak	Damaged oil seal	Replace the copper gasket.
	Rough shaft in oil seal area.	Replace or repair the shaft.
	Incorrect fitting of oil seal.	Replace the gasket.
	Oil level too high.	Drain the oil to the correct level.
	Loose bolts.	Tighten the screws.
Excessive clutch slippage	Clutch linings heavily worn or warped plates.	Repair the clutch according to the shaft operator's manual.
	Shaft load too high.	Reduce ground speed and crop consumption.
	Oil on the linings.	Replace the linings.
	Glazed friction linings.	Wipe with sandpaper.

Uneven cut	Excessive ground speed.	Reduce ground speed.
	Blades worn, dull or bent	Replace the blades.
	Incorrect height adjustment.	Adjust the height of the mower.
	Low tire pressure on one side of the tractor.	Set the tire pressure.
	Too fast turn.	Reduce travel speed when turning
The material is not cut	Excessive ground speed	Reduce ground speed.
	Speed too low	Use full PTO speed.
	Incorrect blade position in relation to cutting direction.	Install the blades so that the rotation is correct.
Poor chopping	Excessive ground speed.	Raise the front of the mower in relation to the rear in order to hold and rotate the material for longer.
	Cut too high.	Lower cutting height.

SER.1.1-012.01.EN

