



PRONAR Sp. z o.o.

17-210 NAREW, UL. MICKIEWICZA 101A, PODLASKIE PROVINCE

tel.:	+48 085 681 63 29	+48 085 681 64 29
	+48 085 681 63 81	+48 085 681 63 82
fax:	+48 085 681 63 83	+48 085 682 71 10

www.pronar.pl

OPERATOR'S MANUAL

SPREADER

PRONAR HPT40

TRANSLATION OF THE ORIGINAL INSTRUCTIONS

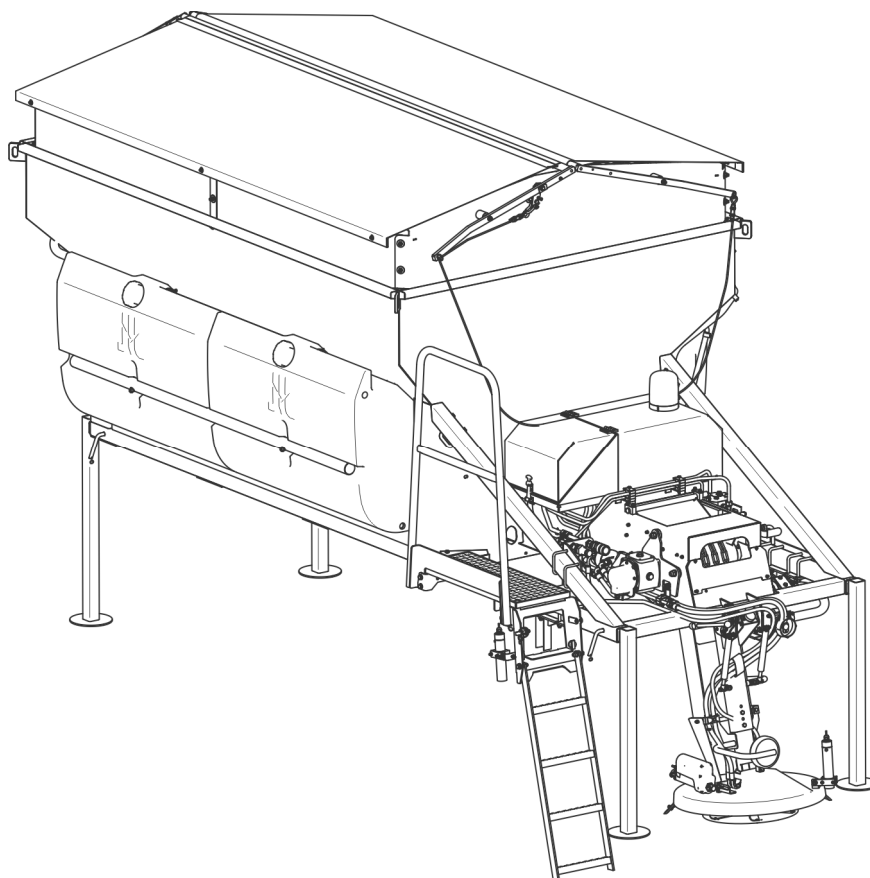

ISSUE 1C-03-2014

PUBLICATION NO 411N-00000000-UM



INTRODUCTION

Information contained herein is current at date of publication. As a result of improvements, some numerical values and illustrations contained in this publication may not correspond to the factual specification of the machine supplied to the user. The manufacturer reserves the right to introduce design changes in machines produced that facilitate operation and improve the quality of their work, without making minor amendments to this Operator's Manual.

This Operator's Manual is an integral part of the machine's documentation. Before using the machine, the user must carefully read this Operator's Manual and observe all recommendations. This guarantees safe operation and ensures malfunction free work of the machine. The machine is designed to meet obligatory standards, documents and legal regulations currently in force.

The manual describes the basic safety rules and operation of the sand spreader. If the information contained in the Operator's Manual needs clarification then the user should refer for assistance to the sale point where the machine was purchased or to the Manufacturer.

MANUFACTURER'S ADDRESS:

*PRONAR Sp. z o.o.
ul. Mickiewicza 101A
17-210 Narew*

CONTACT TELEPHONES

<i>+48 085 681 63 29</i>	<i>+48 085 681 64 29</i>
<i>+48 085 681 63 81</i>	<i>+48 085 681 63 82</i>

SYMBOLS APPEARING IN THIS OPERATOR'S MANUAL

Information, descriptions of danger and precautions and also recommendations and prohibitions associated with user safety instructions are marked:



and also preceded by the word "**DANGER**". Failure to observe the instructions may endanger the machine operator's or other person's health or life.

Particularly important information and instructions, the observance of which is essential, are distinguished in the text by the sign:



and also preceded by the word "**ATTENTION**". Failure to observe the instructions may lead to damage to the machine as a result of improper operation, adjustment or use.

In order to focus the user's attention on the need to perform maintenance, the relevant section of the Operator's Manual is marked with the pictogram:



Additional tips and advice for machine operation are marked:



and also preceded by the word „**TIP**”.

DIRECTIONS USED IN THIS OPERATOR'S MANUAL

Left side – side to the left hand of the operator facing in the direction of machine's forward travel.

Right side – side to the right hand of the operator facing in the direction of machine's forward travel.



PRONAR Sp. z o.o.

ul. Mickiewicza 101 A
17-210 Narew, Polska

tel./fax (+48 85) 681 63 29, 681 63 81, 681 63 82,
681 63 84, 681 64 29

fax (+48 85) 681 63 83

<http://www.pronar.pl>

e-mail: pronar@pronar.pl

EC DECLARATION OF CONFORMITY OF THE MACHINERY

PRONAR Sp. z o.o. declares with full responsibility, that the machine:

Description and identification of the machinery	
Generic denomination and function:	Spreader
Type:	HPT40
Model:	—
Serial number:	
Commercial name:	Spreader PRONAR HPT40

to which this declaration relates, fulfills all the relevant provisions of the Directive **2006/42/EC** of The European Parliament and of The Council of 17 May 2006 on machinery, and amending Directive 95/16/EC (Official Journal of the EU, L 157/24 of 09.06.2006).

The person authorized to compile the technical file is the Head of Research and Development Department at PRONAR Sp. z o.o., 17-210 Narew, ul. Mickiewicza 101A, Poland.

This declaration relates exclusively to the machinery in the state in which it was placed on the market, and excludes components which are added and/or operations carried out subsequently by the final user.

Narew, the 2014-06-03

Place and date

Z-CIA DYREKTORA
d/s technicznych
członek zarządu
Roman Orzechaniuk

*Full name of the empowered person
position, signature*

TABLE OF CONTENTS

1	BASIC INFORMATION	1.1
1.1	IDENTIFICATION	1.2
1.2	PROPER USE	1.3
1.3	EQUIPMENT	1.5
1.4	TERMS & CONDITIONS OF WARRANTY	1.5
1.5	TRANSPORT	1.7
1.6	ENVIRONMENTAL HAZARDS	1.9
1.7	WITHDRAWAL FROM USE	1.9
2	SAFETY ADVICE	2.1
2.1	BASIC SAFETY RULES	2.2
2.1.1	USE OF MACHINE	2.2
2.1.2	HITCHING TO CARRYING VEHICLE	2.3
2.1.3	HYDRAULIC SYSTEM	2.3
2.1.4	MAINTENANCE	2.4
2.1.5	MACHINE OPERATION	2.5
2.2	DESCRIPTION OF RESIDUAL RISK	2.7
2.3	INFORMATION AND WARNING DECALS	2.8
3	DESIGN AND OPERATION	3.1
3.1	TECHNICAL SPECIFICATION	3.2
3.2	GENERAL DESIGN	3.4
3.3	HYDRAULIC SYSTEM	3.5
3.4	BRINE SPRAY SYSTEM	3.6
3.5	HOPPER SYSTEM AND SPREADING SYSTEM	3.7
3.6	ELECTRICAL SYSTEM	3.8

4	CORRECT USE	4.1
4.1	PREPARING FOR WORK BEFORE FIRST USE	4.2
4.2	CHECKING TECHNICAL CONDITION	4.4
4.3	MACHINE INSTALLATION	4.5
4.3.1	INSTALLING THE MACHINE ON THE CARRYING VEHICLE'S LOAD PLATFORM	4.5
4.3.2	SECURING THE MACHINE TO THE CARRYING VEHICLE'S LOAD PLATFORM	4.8
4.3.3	CONNECTING CONTROL ELECTRICAL SYSTEM	4.12
4.3.4	CONNECTING HYDRAULIC SYSTEM	4.12
4.4	PREPARING FOR WORK	4.14
4.4.1	SETTING THE SPREADING MECHANISM	4.14
4.5	LOADING THE MACHINE	4.17
4.5.1	LOADING THE TANK	4.17
4.5.2	FILLING THE TANK WITH BRINE	4.19
4.6	CONTROL PANEL	4.21
4.6.1	GENERAL DESIGN AND OPERATION	4.21
4.6.2	DESCRIPTION OF CONTROL PANEL MENU	4.22
4.7	MACHINE OPERATION	4.28
4.7.1	CHANGING WIDTH AND ASYMMETRY OF SPREADING	4.32
4.7.2	OPERATION IN AUTOMATIC MODE (OPTION)	4.33
4.8	DRIVING ON PUBLIC ROADS	4.36
4.9	UNLOADING	4.37
4.9.1	EMPTYING THE TANK	4.37
4.9.2	EMPTYING BRINE TANKS	4.39
4.10	DISMOUNTING THE MACHINE FROM THE CARRYING VEHICLE'S LOAD PLATFORM	4.40

5 MAINTENANCE	5.1
5.1 HYDRAULIC SYSTEM OPERATION	5.2
5.2 ELECTRICAL SYSTEM MAINTENANCE	5.4
5.3 MAINTENANCE OF BELT CONVEYOR	5.7
5.3.1 CHANGING OIL IN THE CONVEYOR DRIVE TRANSMISSION	5.7
5.3.2 ADJUSTMENT OF CONVEYOR BELT	5.8
5.3.3 INSPECTION AND REPLACEMENT OF CONVEYOR BELT BRUSHES	5.10
5.4 MAINTENANCE OF BRINE SPRAY SYSTEM	5.12
5.5 ADJUSTMENT OF SPREADING MECHANISM	5.13
5.6 REPLACING SPREADING DISC BLADES	5.14
5.7 LUBRICATION	5.15
5.8 STORAGE	5.16
5.9 TIGHTENING TORQUE FOR NUT AND BOLT CONNECTIONS	5.18
5.10 TROUBLESHOOTING	5.19

SECTION

1

**BASIC
INFORMATION**

1.1 IDENTIFICATION

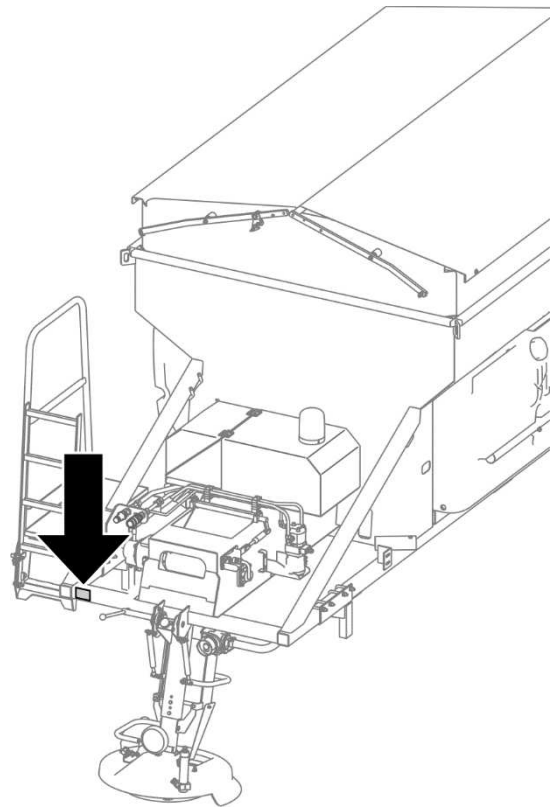
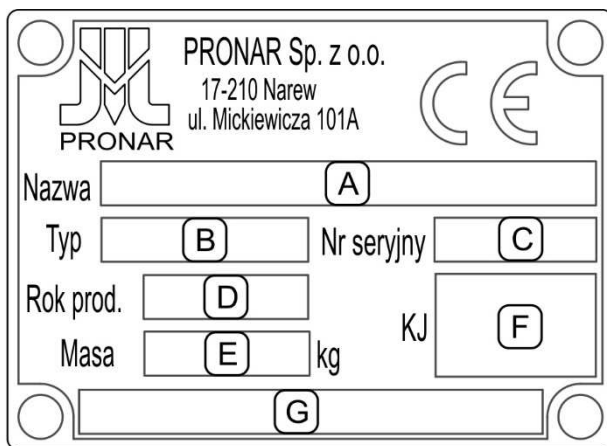

FIG. 1.1 Location of the data plate

Meaning of data plate items (FIG. 1.1):

- A - machine name
- B – type,
- C – serial number
- D – year of manufacture
- E – machine tare weight [kg]
- F – Quality Control stamp
- G – unfilled box or additional information

The factory number is stamped into the data plate and on mounting base beside the data plate. Data plate is located at the rear of the machine, on the frame next to the fixing point of the left parking support (FIG. 1.1). When buying the machine, confirm that the serial number on the machine corresponds to the number indicated in the *WARRANTY BOOK*, in the sales documents and in the *OPERATOR'S MANUAL*.

1.2 PROPER USE

PRONAR HPT40 sand spreader is used for surface spreading of coarse materials (sand, aggregate) and chemical agents (sodium chloride, calcium chloride, magnesium chloride, brine) for winter road maintenance. Use for other purposes should be regarded as improper. The sand spreader can be mounted on trucks that are equipped with a load platform and that meet the requirements set out in Table 1.1

Using it as intended also involves all actions connected with the safe and proper operation and maintenance of the machine. Due to the above, the user is obliged to:

- carefully read the OPERATOR'S MANUAL and comply with its recommendations,
- understand the machine's operating principle and how to operate it safely and correctly,
- comply with general safety regulations while working,
- prevent accidents,
- comply with road traffic regulations.

The machine may only be used by persons, who:

- are familiar with the contents of this publication and with the contents of the vehicle Operator's Manual
- have been trained in machine operation and safe working conditions,
- have the required authorisation to drive the vehicle and are familiar with the road traffic regulations and transport regulations.

IMPORTANT



The machine must not be used for purposes other than those for which it is intended, in particular for:

- for transporting people, animals
- for transporting whatever materials
- spreading other materials than those specified in the Operator's Manual

TAB. 1.1 Carrying vehicle requirements

	UNIT	REQUIREMENTS
Mounting method	–	on the carrying vehicle's load platform by means of LC 2000N securing tapes according to EN 12195-22 standard
Minimum load platform dimensions:		
– length / width	mm	3 850 / 2 300
– height from the ground	mm	950 ÷ 1 700
Carrying vehicle load capacity	t	10/11/12*
Voltage of electrical system of control electronics	V	24
Hydraulic system	–	Supply and return, designed for continuous operation
Oil flow (min)	dm ³ /min	35
Oil nominal pressure	MPa	16
Type of oil	–	hydraulic, HL32
Type and number of hydraulic connectors	–	HQ19-F-12G ISO16028 - 1 item HQ19-M-12G ISO16028 - 1 item located at the rear or on the side of carrying vehicle**
Other requirements	–	connection with travel speed pulse input according to ISO 16844-2

* - depending on setting of the sand spreader's tank capacity

** - depending on the sand spreader version

1.3 EQUIPMENT

The sand spreader equipment includes:

- Operator's Manual,
- Warranty Book,
- parking supports

Additional (optional) equipment:

- parking stands *(for removing and installing the machine on the carrying vehicle's load platform without the use of lifting equipment)*
- oil filter *(additional pressure oil filter in the hydraulic system)*
- side bumpers *(when the sand spreader is mounted on carrying vehicle with strong side boards; side bumpers are used together with parking stands)*
- automatic control *(automatic change of parameters depending on selected working mode and temperature)*
- hydraulic connectors at the rear of the carrying vehicle *(hydraulic conduits with HQ19-F-12G and HQ19-M-12G connectors for connecting to UNIMOG U500 vehicles with wheel base of 3 900mm)*
- hydraulic connectors on the side of the carrying vehicle *(hydraulic conduits with HQ19-F-12G and HQ19-M-12G connectors for connecting to UNIMOG U500 vehicles with wheel base of 3 900mm)*
- control panel bracket *(for mounting the control panel in UNIMOG U500 vehicles)*

1.4 TERMS & CONDITIONS OF WARRANTY

PRONAR Sp. z o.o., Narew guarantees the reliable operation of the machine when it is used according to its intended purpose as described in the *OPERATOR'S MANUAL*. Defects discovered during the warranty period will be removed by the Warranty Service. The repair period is specified in the *WARRANTY BOOK*.

The warranty does not apply to those parts and sub-assemblies of the machine, which are subject to wear in normal usage conditions, regardless of the warranty period.

The warranty service only applies to factory defects and mechanical damage that is not due to the user's fault.

In the event of damage arising from:

- mechanical damage which is the user's fault, caused by road accidents,
- by inappropriate use, adjustment or maintenance, use of the machine for purposes other than those for which it is intended,
- use of damaged or malfunctioning machine,
- repairs carried out by unauthorised persons, improperly carried out repairs,
- making unauthorised alterations to machine design,

the user will lose the right to warranty service.

**TIP**

Demand that the seller carefully and precisely fills out the *WARRANTY BOOK* and warranty repair coupons. A missing date of purchase or sale point stamp, may make the user ineligible for any warranty repair or refund.

For detailed Terms & Conditions of Warranty, please refer to the *WARRANTY BOOK* attached to each machine.

Modification of the machine without the written consent of the Manufacturer is forbidden. In particular, do NOT weld, drill holes in, cut or heat the main structural elements, which have a direct impact on the machine operation safety.

1.5 TRANSPORT

The machine is prepared for sale completely assembled and does not require packing. Packing is only required for the machine's operation and maintenance manual and control panel with a wiring harness.

The machine is delivered to the user by transport vehicle, after being attached to the load platform. The machine should be firmly secured by means of certified fastening straps fitted with a tightening mechanism.

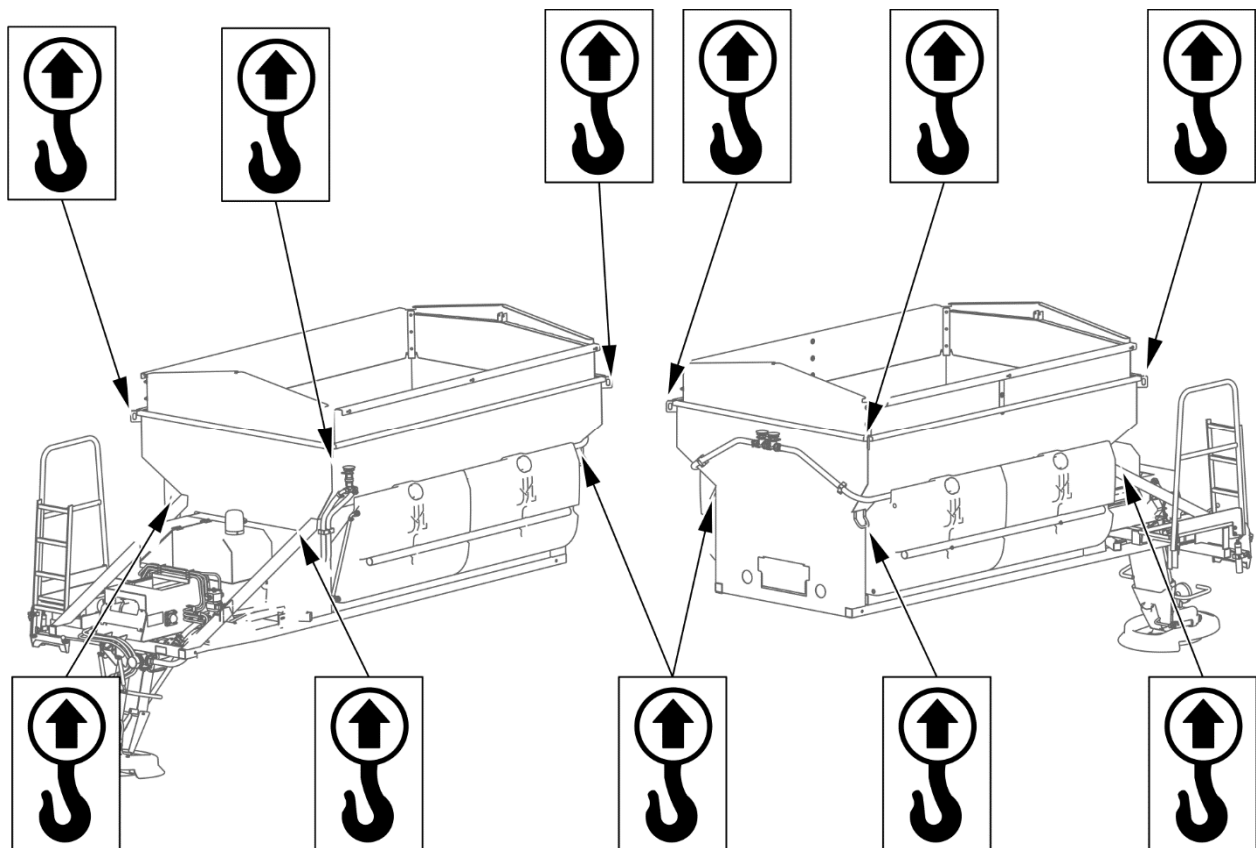

FIG. 1.2 Transport lugs



DANGER

When being transported on a motor vehicle the machine must be mounted on the vehicle's platform in accordance with the transport safety requirements. The driver of the vehicle should take particular care while transporting the machine. This is due to the vehicle's centre of gravity shifting upwards when loaded with the machine.

When loading and unloading the machine, comply with the general principles of workplace health and safety for reloading work. Persons operating reloading equipment must have the qualifications required to operate these machines.

The machine should be attached to lifting equipment in places specially designed for this purpose (FIG. 1.2), i.e. by the lugs on the sides of the tank (4 points) and grips on the frame (4 points). Suspension points are identified with information decals. When lifting the machine take particular care due to the possibility of tipping over the machine and the risk of injuries from protruding parts. To keep lifted machine in the correct direction it is recommended to apply additional guy cables. During the loading work particular care should be taken not to damage paint coating.

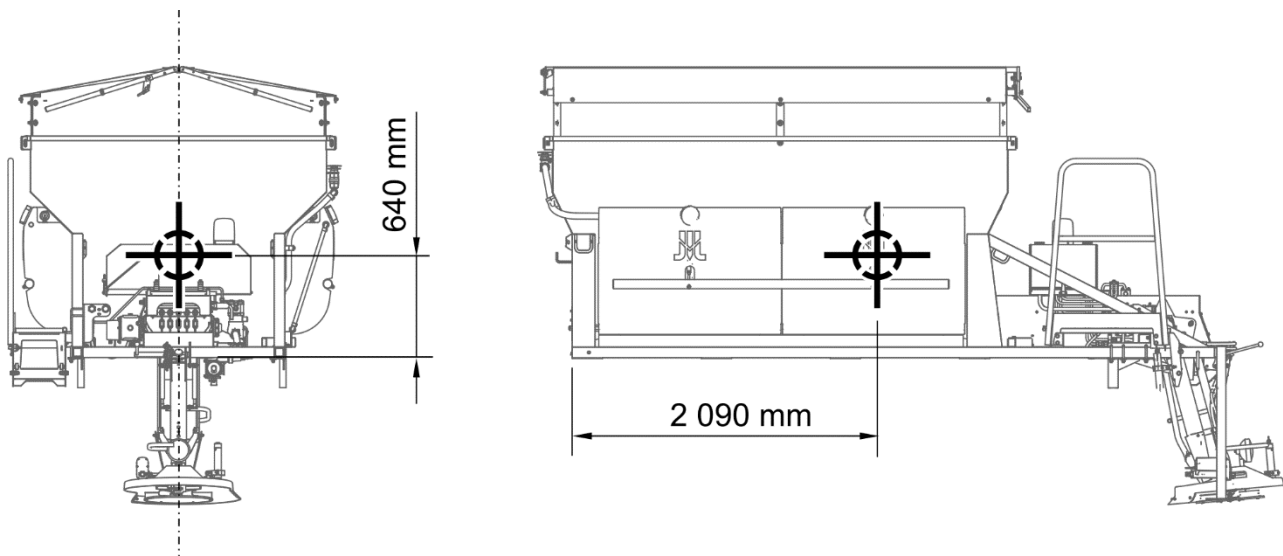

FIG. 1.3 Location of centre of gravity (*empty tanks*)

	ATTENTION!
Depending on the machine setting, location of centre of gravity varies in the range of ± 100 mm	

1.6 ENVIRONMENTAL HAZARDS

A hydraulic oil leak constitutes a direct threat to the natural environment owing to its limited biodegradability. Maintenance and repair work which involves the risk of an oil leak should be performed in the rooms with oil resistant surface. In the event of oil leaking into the environment, first of all contain the source of the leak, and then collect the leaked oil using available means. Remaining oil should be collected using sorbents, or by mixing the oil with sand, sawdust or other absorbent materials. The oil pollution, once gathered up, should be kept in a sealed, marked, hydrocarbon resistant container, and then passed on to the appropriate oil waste recycling centre. The container should be kept away from heat sources, flammable materials and food.

Oil, which has been used up or is unsuitable for further use owing to a loss of its properties should be stored in its original packaging in the conditions described above.

1.7 WITHDRAWAL FROM USE

In the event of decision by the user to withdraw the machine from use, comply with the regulations in force in the given country concerning withdrawal from use and recycling of machines withdrawn from use.

Before proceeding to dismantle equipment, oil shall be completely removed from hydraulic system and transmission.

When spare parts are changed, worn out or damaged parts should be taken to a collection point for recyclable raw materials. Waste oil and also rubber and plastic elements should be taken to establishments undertaking the utilisation of such waste.



IMPORTANT

During dismantling personal protection equipment shall be used i.e. protective clothing, boots, gloves and protective goggles etc.

Avoid contact of skin with oil. Do not allow used oil to spill.

SECTION

2

SAFETY ADVICE

2.1 BASIC SAFETY RULES

2.1.1 USE OF MACHINE

- Before using the machine, the user must carefully read this Operator's Manual and the *WARRANTY BOOK*. When operating the machine, the operator must comply with the recommendations.
- The machine may only be used and operated by persons qualified to drive the carrying vehicle and trained in the use of the machine.
- If the information stated in the Operator's Manual is difficult to understand, contact a seller, who runs an authorised technical service on behalf of the Manufacturer, or contact the Manufacturer directly.
- Careless and improper use and operation of the machine, and non-compliance with the recommendations given in this operator's manual is dangerous to your health.
- Be aware of the existence of a residual risk, and for this reason the fundamental basis for using this machine should be the application of safety rules and sensible behaviour.
- The machine must never be used by unauthorised persons, including children, and people under the influence of alcohol or other abusive substances.
- Non-compliance with the safety rules of this Operator's Manual can be dangerous to the health and life of the operator and others.
- The machine must not be used for purposes other than those for which it is intended. Anyone who uses the machine other than the way intended takes full responsibility for himself for any consequences of this use. Use other than intended means using the sand spreader in any way other than that specified in the Operator's Manual including also spreading of other agents than those recommended by the Manufacturer.
- The machine may only be used when all the protective elements (i.e. safety guards) are technically sound and correctly positioned. In the event of loss or destruction of the safety guards, they must be replaced with new ones.

2.1.2 HITCHING TO CARRYING VEHICLE

- The carrying vehicle to which the machine will be coupled must be technically reliable and must fulfil the requirements of the machine Manufacturer.
- The machine should be secured to the carrying vehicle by means of suitable certified belts or chains.
- Be especially careful when hitching the machine to carrying vehicle.
- When hitching, there must be nobody between the machine and the carrying vehicle.
- After completion of coupling the machine, check the safeguards. Carefully read the carrying vehicle Operator's Manual.
- Be especially careful when unhitching the machine from the carrying vehicle.
- Machine removed from the carrying vehicle must be placed on parking stands, on level, sufficiently hard surface in such a manner as to ensure that it is possible to connect it again.

2.1.3 HYDRAULIC SYSTEM

- The hydraulic system is under high pressure when operating.
- Regularly check the technical condition of the connections and the hydraulic lines. There must be no oil leaks.
- In the event of the hydraulic system malfunction, discontinue using the machine until the malfunction is corrected.
- In the event of injuries being caused by pressurised hydraulic oil, contact a doctor immediately. Hydraulic oil may find its way under the skin and cause infections. In the event of contact of oil with eye, rinse with large quantity of water and in the event of the occurrence of irritation consult a doctor. In the event of contact of oil with skin wash the area of contact with water and soap. Do NOT apply organic solvents (petrol, kerosene).
- Use the oil recommended by the Manufacturer. Never mix two types of oil.
- Used oil or oil, which has lost its properties, should be stored in original containers or replacement containers resistant to action of hydrocarbons. Replacement containers must be clearly marked and appropriately stored.

- Do not store hydraulic oil in packaging designed for storing food or foodstuffs.
- Rubber hydraulic conduits must be replaced every 4 years regardless of their technical condition.
- Repair and replacement of hydraulic system elements should be entrusted to the appropriately qualified persons.

2.1.4 MAINTENANCE

- During the warranty period, any repairs may only be carried out by Warranty Service authorised by the manufacturer. It is recommended that necessary repairs to machine should be undertaken by specialised workshops.
- In the event of any fault or damage whatsoever, do not use the machine until the fault has been corrected.
- During work on the machine use the proper, close-fitting protective clothing, gloves and appropriate tools. When working on hydraulic systems it is recommended to use oil resistant gloves and protective goggles.
- Any modification to the machine frees PRONAR from any responsibility for damage or detriment to health which may arise as a result.
- The sand spreader can only be stood on when it is absolutely motionless and the carrying vehicle engine is switched off. Before climbing onto the sand spreader, immobilise the carrying vehicle with parking brake, secure against unauthorized access and remove key from ignition.
- Before undertaking any work on the machine, turn off carrying vehicle's engine.
- Regularly check the technical condition of the safety devices and correct tightening of bolt connections.
- Regularly perform service inspections of machine as recommended by the Manufacturer.
- Before beginning work on hydraulic systems, reduce oil pressure.
- Servicing and repair work should be carried out in line with the general principles of workplace health and safety. In the event of injury, the wound must be immediately cleaned and disinfected. In the event of more serious injuries, seek a doctor's advice.

- Should it be necessary to change individual parts, use only original parts. Non-adherence to these requirements may put the user and other people's health and life at risk, and also damage the machine and invalidate the warranty.
- Regularly check technical condition and mounting of all guards and protective elements.
- Before welding or electrical work, the sand spreader should be disconnected from the electrical system. The paint coating should be cleaned. Burning paint fumes are poisonous for people and animals. Welding work should be carried out in a well lit and well ventilated space.
- In the event of work requiring the machine to be raised, use properly certified hydraulic or mechanical lifts. After lifting the machine, stable and durable supports must also be used. Do NOT carry out work under a machine, which has only been raised with the jack or which stands on parking supports or parking stands.
- The machine must not be supported using fragile elements (bricks or concrete blocks).
- After completing work associated with lubrication, remove excess of lubricant.
- Used lubricants should be disposed of.
- In order to reduce the danger of fire the machine must be kept in a clean condition.

2.1.5 MACHINE OPERATION

- Before using the sand spreader always check its technical condition. In particular, check the technical condition of indicator lights, spreading mechanism, feeding mechanism and protective shields.
- The sand spreader drive may be started only when there are no bystanders or animals within the radius about two times larger than the set spreading width. The machine operator is obliged to ensure proper visibility of the machine and the working area.
- During machine operation do not occupy a different position than that of the operator in the vehicle's cab. Do NOT leave the cab, when the machine is in operation.

- There must be no bystanders within the machine spreading zone.
- Do not approach the machine until the rotating parts come to a complete standstill.
- When working near pavements or on public roads there is a risk that thrown out particles of sand, salt, stones etc. may pose a threat to bystanders.
- Before loading sand spreader make certain that there are no stones, tools or other objects in the load box and on the spreading disc.
- Load should be uniformly distributed in the machine tank.
- Do NOT exceed permissible load weight of sand spreader because this may cause danger to road traffic and cause damage to the machine.
- Spreading agents must be prepared in accordance with the regulations concerning winter road maintenance in force in the country in which the sand spreader is used. Spreading agents other than those recommended by the Manufacturer must not be used.
- While working with the sand spreader, turn on the beacon light and the light near the spreading disc.
- Exercise particular caution while reversing.
- When spreading is completed, disengage the hydraulic drive of the feeding and spreading mechanisms.
- When driving on public roads, comply with the road traffic regulations. in force in the country, in which the machine is used.
- Adjust travel speed to the prevailing road conditions and other limitations arising from road traffic regulations limits.
- Do not carry people or animals on the machine.
- Reckless driving and excessive speed may cause accidents.

2.2 DESCRIPTION OF RESIDUAL RISK

Pronar Sp. z o. o. in Narew has made every effort to eliminate the risk of accidents. There is, however, a certain residual risk, which could lead to an accident, and this is connected mainly with the actions described below:

- using the sand spreader for purposes other than those for which it is intended,
- being between the carrying vehicle and the machine while the machine is being attached,
- being on the machine while the engine is running,
- operating the machine with removed or faulty safety guards,
- not maintaining safe distance from the danger zone or being within the zones while the machine is operating,
- operation of the machine by unauthorised persons or persons under the influence of intoxicating substances,
- cleaning, maintenance and technical checks when carrying vehicle is connected and engine is running



The residual risk may be kept to a minimum by following the recommendations below:



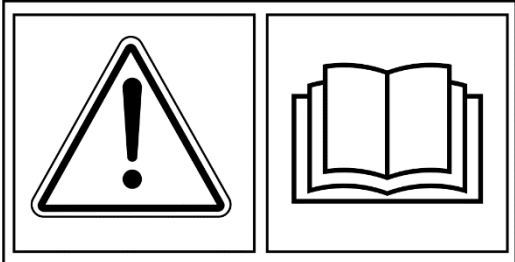
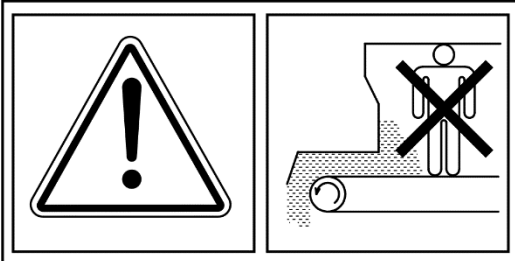

- prudent and unhurried operation of the machine,
- sensible application of the remarks and recommendations stated in the Operator's Manual,
- carrying out repair and maintenance work in line with operating safety rules,
- carrying out repair and maintenance work by persons trained to do so,
- using close fitting protective clothing,
- ensuring unauthorised persons have no access to the machine, especially children,
- maintaining safe distance from forbidden or dangerous places
- a ban on being on the machine when it is operating

2.3 INFORMATION AND WARNING DECALS

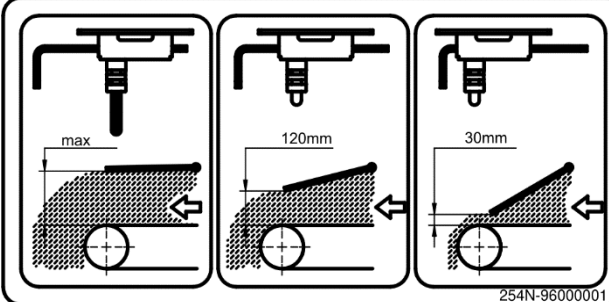
All signs should always be legible and clean, visible to the operator and also to persons possibly being in the vicinity of the machine in operation. If any safety sign is lost or illegible, it should be replaced with a new one. All elements having safety signs replaced during repairs should be affixed with these signs. Safety signs and decals may be purchased from the Manufacturer or the Seller.

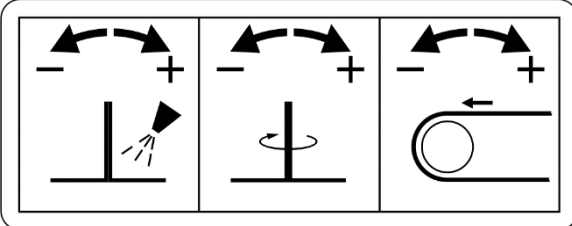
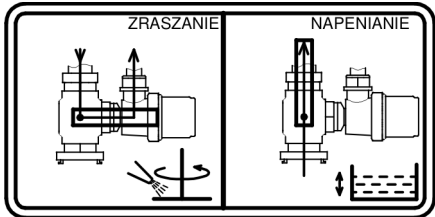
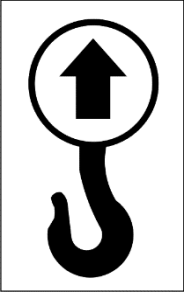
TAB. 2.1 Information and warning decals

ITEM	SYMBOL	DESCRIPTION
1		<p>Before starting work, carefully read the Operator's Manual.</p>
2		<p>Do not enter the tank; do not stand on the feeding mechanism if the machine drive is engaged</p>
3		<p>Danger caused by materials thrown out by the machine. Keep a safe distance from the operating machine.</p>
4		<p>Information decal Control of the feeding mechanism barrier</p>

ITEM	SYMBOL	DESCRIPTION
5		<p>Information decal Manual control of hydraulic block.</p>
6		<p>Information decal control of the brine valve</p>
7		<p>Lifting equipment attachment points while loading the machine</p>
8		<p>Outline marking.</p>
9		<p>Information decal</p>
10		<p>Machine model</p>

Numbers in the item column correspond to decals (FIG. 2.1)

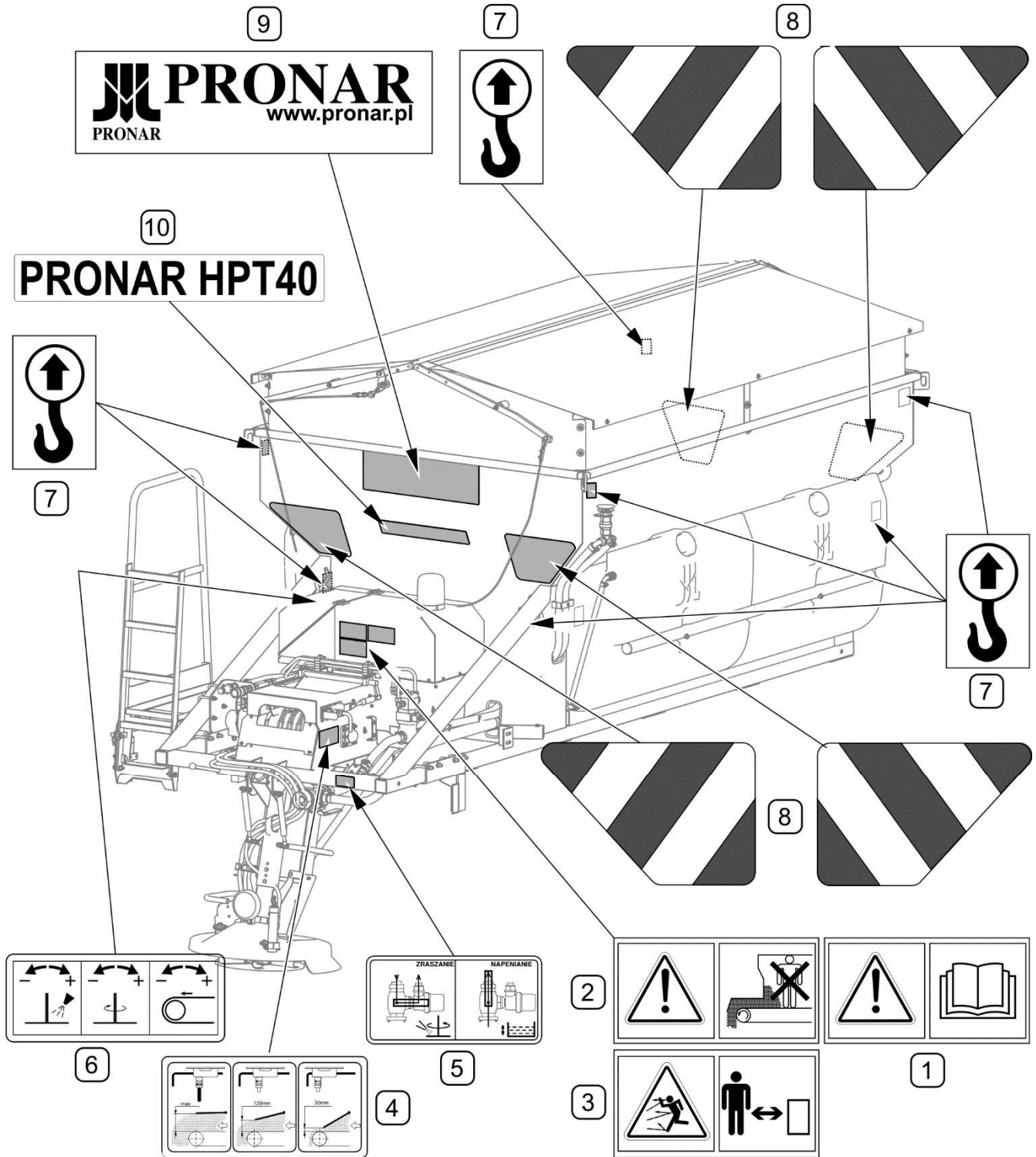

FIG. 2.1 Locations of information and warning decals.

Meanings of symbols are described in TAB. 2.1

SECTION

3

**DESIGN AND
OPERATION**

3.1 TECHNICAL SPECIFICATION

TAB. 3.1 BASIC TECHNICAL SPECIFICATION

	Unit	
Mounting method	–	by means of fastening straps on the truck's loading platform
Spreading width:		
– minimum	m	2
– maximum	m	12
Spreading density:		
– chemical agents	g/m ²	5 – 40
– coarse materials	g/m ²	50 – 200
Tank capacity	m ³	4,5* / 5,25* / 6*
Capacity of brine tanks	dm ³	1,800
Number of spreading discs	pc.	1
Number of spreading disc blades	pc.	6
Machine drive	–	external carrying vehicle hydraulic system
Operation	–	with the aid of the control panel, from the operator cab
Electric power supply	V	24V
Pressure in the hydraulic system	MPa	16
Working speed	km/h	10 – 70
Machine weight (without load)	kg	1,600
Height of the machine from the carrying vehicle's load platform	mm	1 660* / 1 790* / 1 920*

* - depending on setting of tank extension walls

Level of noise emitted by machine does not exceed 70 dB(A)

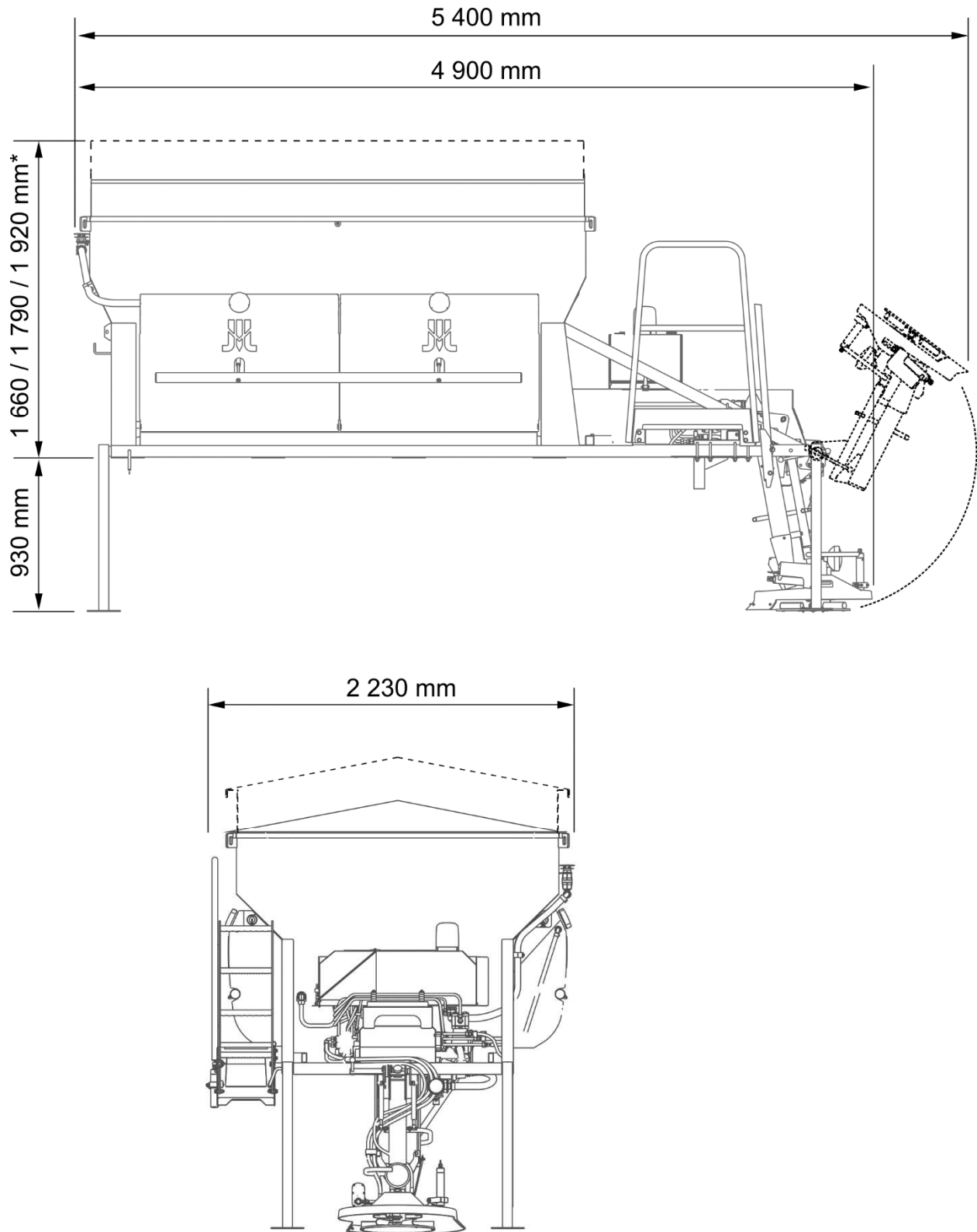

FIG. 3.1 External dimensions of HPT40 sand spreader

* - depending on setting of tank extension walls

3.2 GENERAL DESIGN

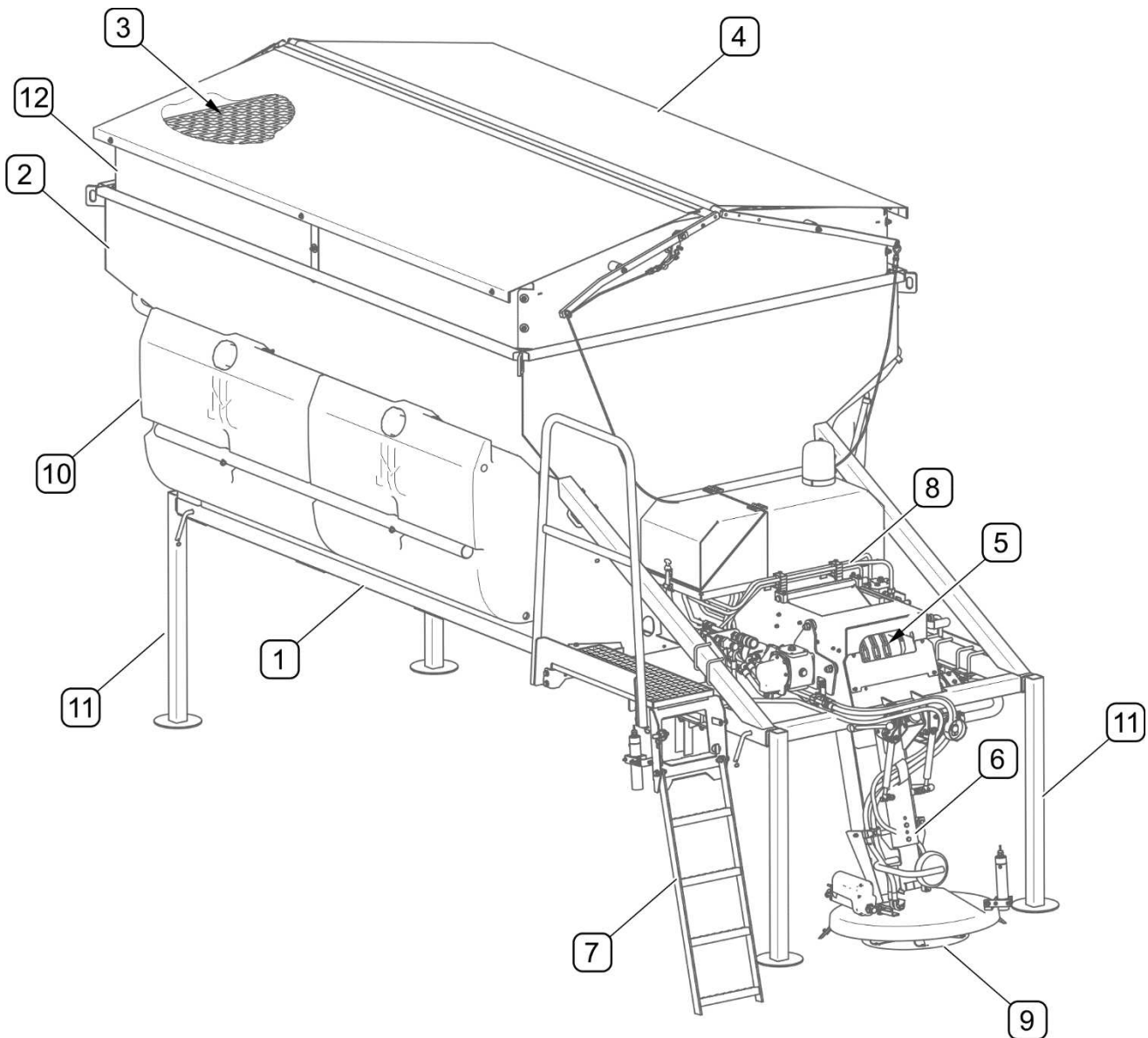

FIG. 3.2 General design

(1) - frame; (2) - tank; (3) - screen; (4) - tarpaulin cover; (5) - belt conveyor; (6) - hopper system; (7) - ladder; (8) - hydraulic system; (9) - spreading mechanism; (10) - tanks of brine spray system; (11) - parking supports; (12) - adjustable wall extensions

Sand spreader consists of a frame (1), whose integral part is a tank (2) equipped with a screen (3) and a frame with tarpaulin cover (4). Belt conveyor (5) located at the bottom of tank (2) carries the material to hopper unit (6), which feeds the material to disc blades of spreading mechanism (9). Additionally, brine spray system (10) enables feeding of brine to

the spreading mechanism. Working parameters are monitored and controlled from the carrying vehicle's cab by means of a control panel with a display.

3.3 HYDRAULIC SYSTEM

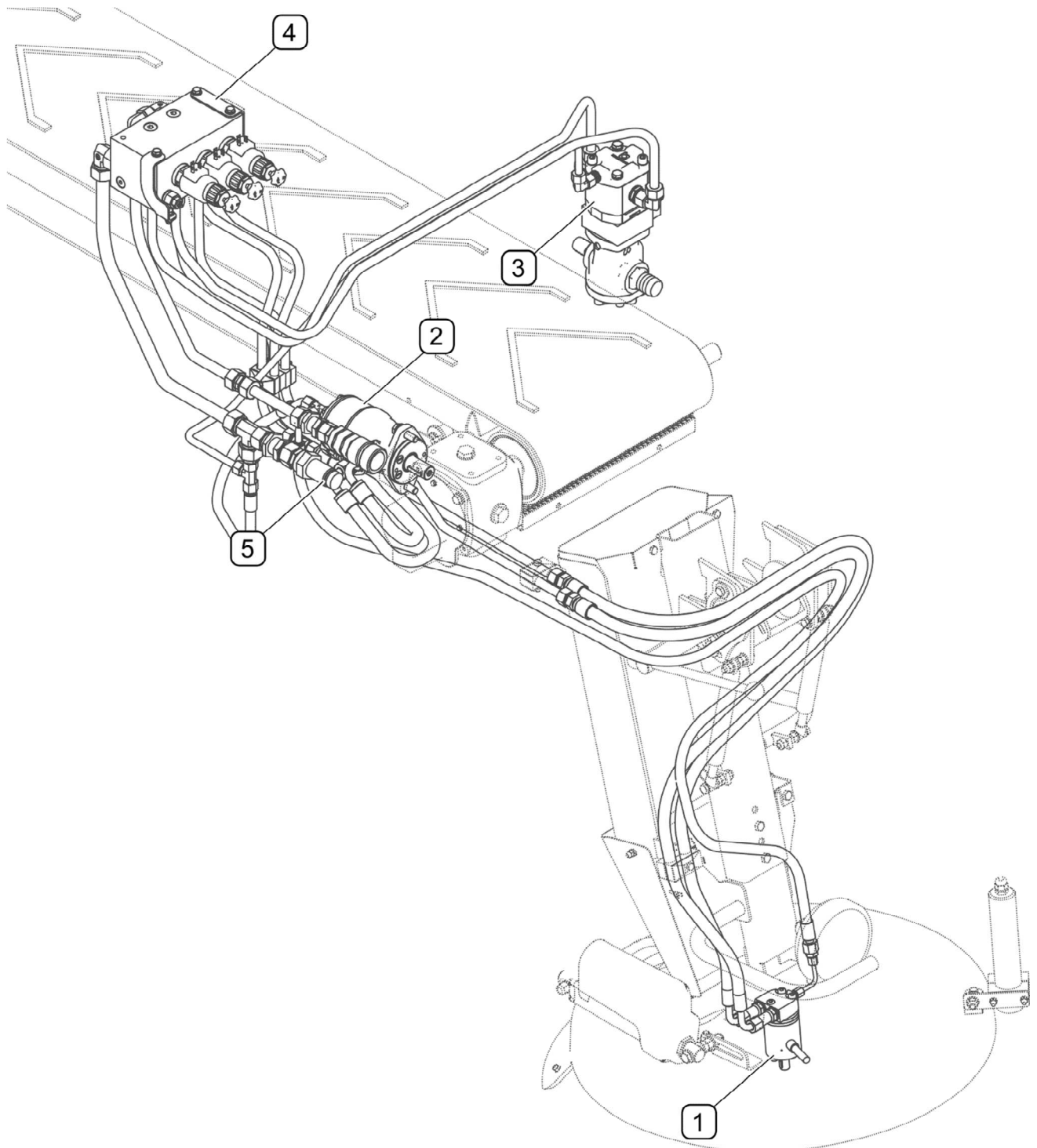

FIG. 3.3 Hydraulic system design

(1) - hydraulic motor of spreading disk; (2) - hydraulic motor of conveyor; (3) - hydraulic motor of brine pump; (4) - valve block; (5) - hydraulic quick coupler

3.4 BRINE SPRAY SYSTEM

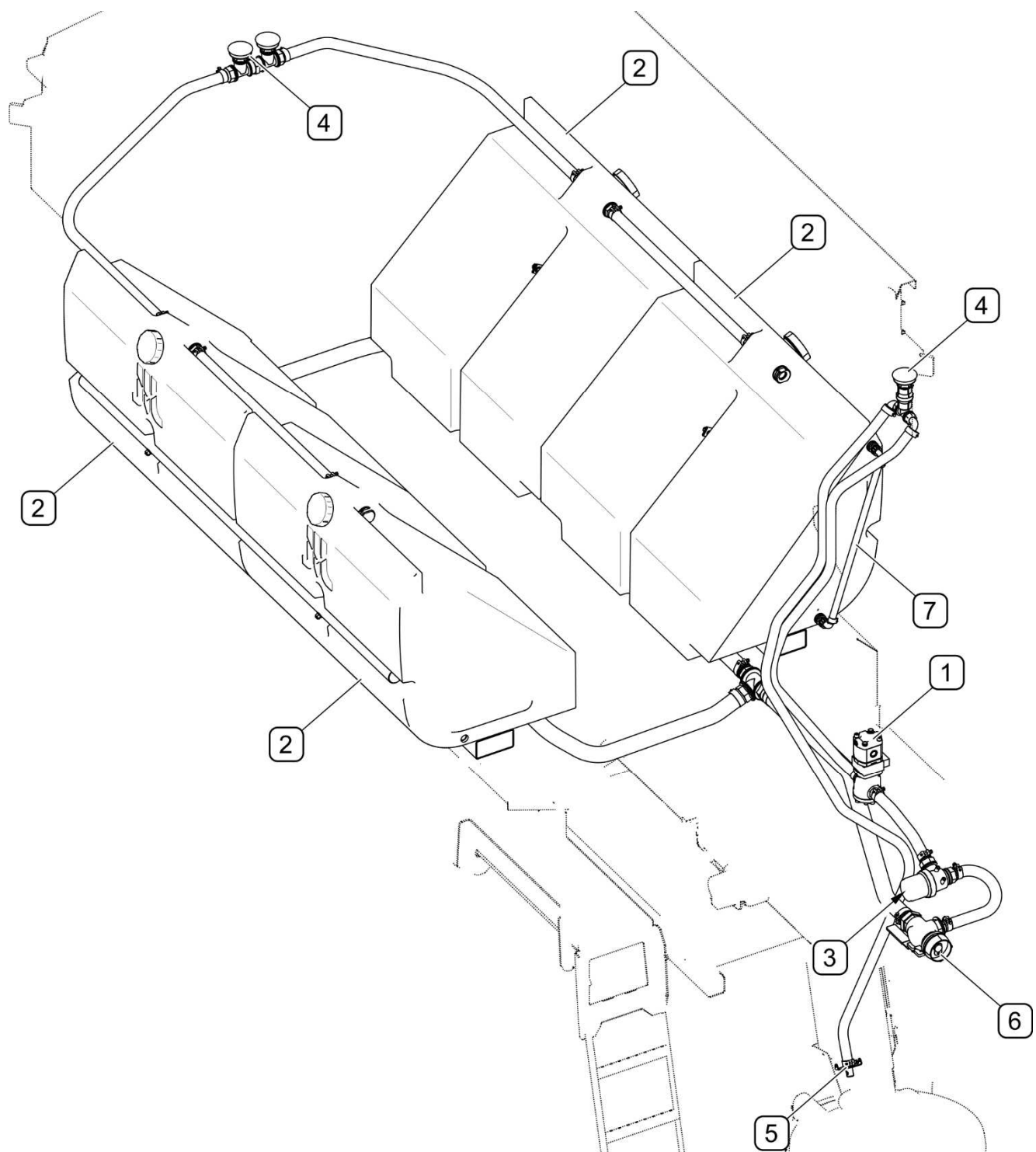

FIG. 3.4 Design of brine spray system

(1) - pump; (2) - tank; (3) - filter; (4) - air vent; (5) - connector pipe; (6) - filling valve;
(7) - brine level indicator

3.5 HOPPER SYSTEM AND SPREADING SYSTEM

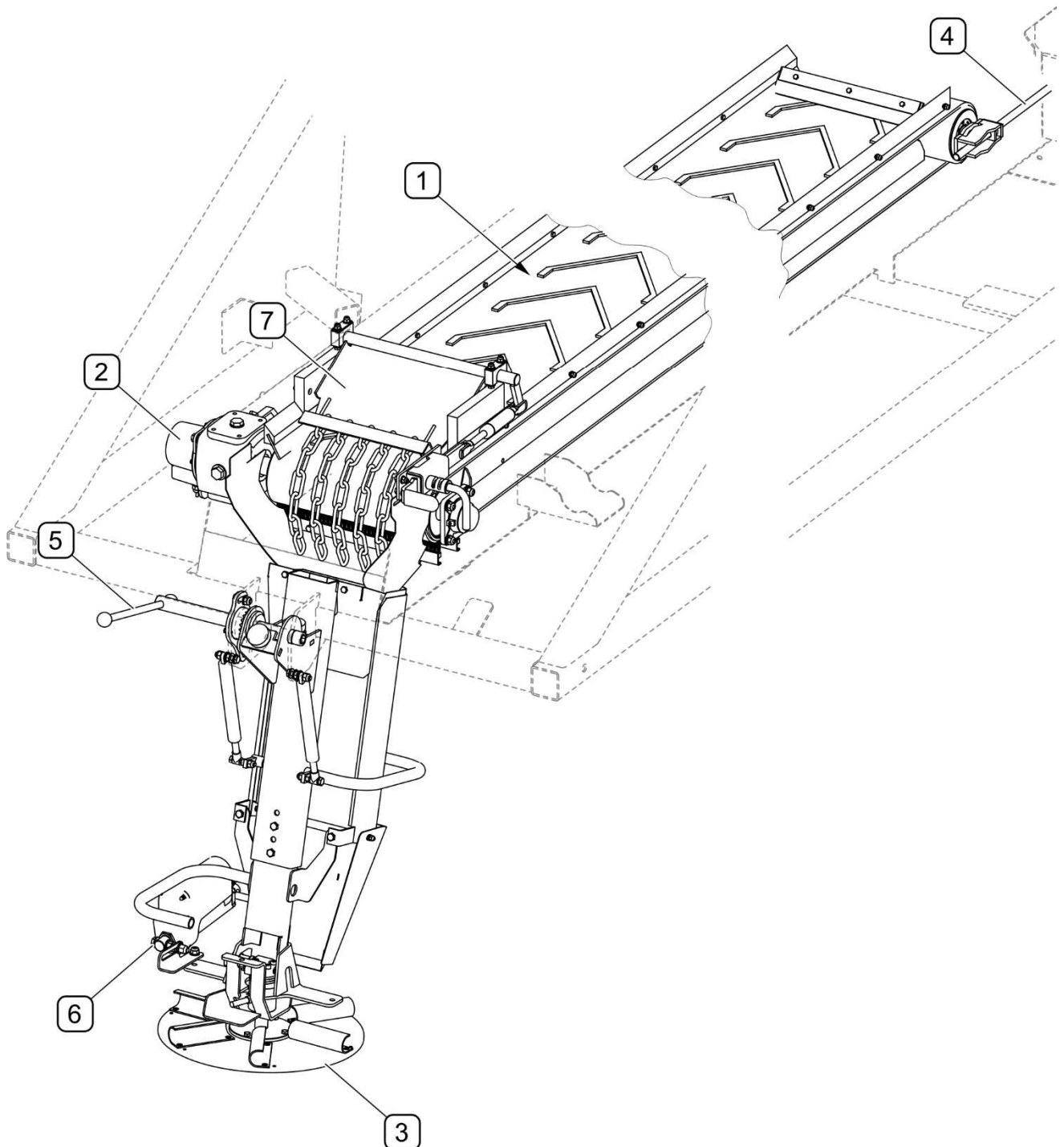

FIG. 3.5 Design of hopper system and spreading system

(1) - belt conveyor; (2) - transmission; (3) - spreading disc; (4) - conveyor tensioner;
(5) - rising interlock lever; (6) - spreading direction adjusting cylinder; (7) - shutter

3.6 ELECTRICAL SYSTEM

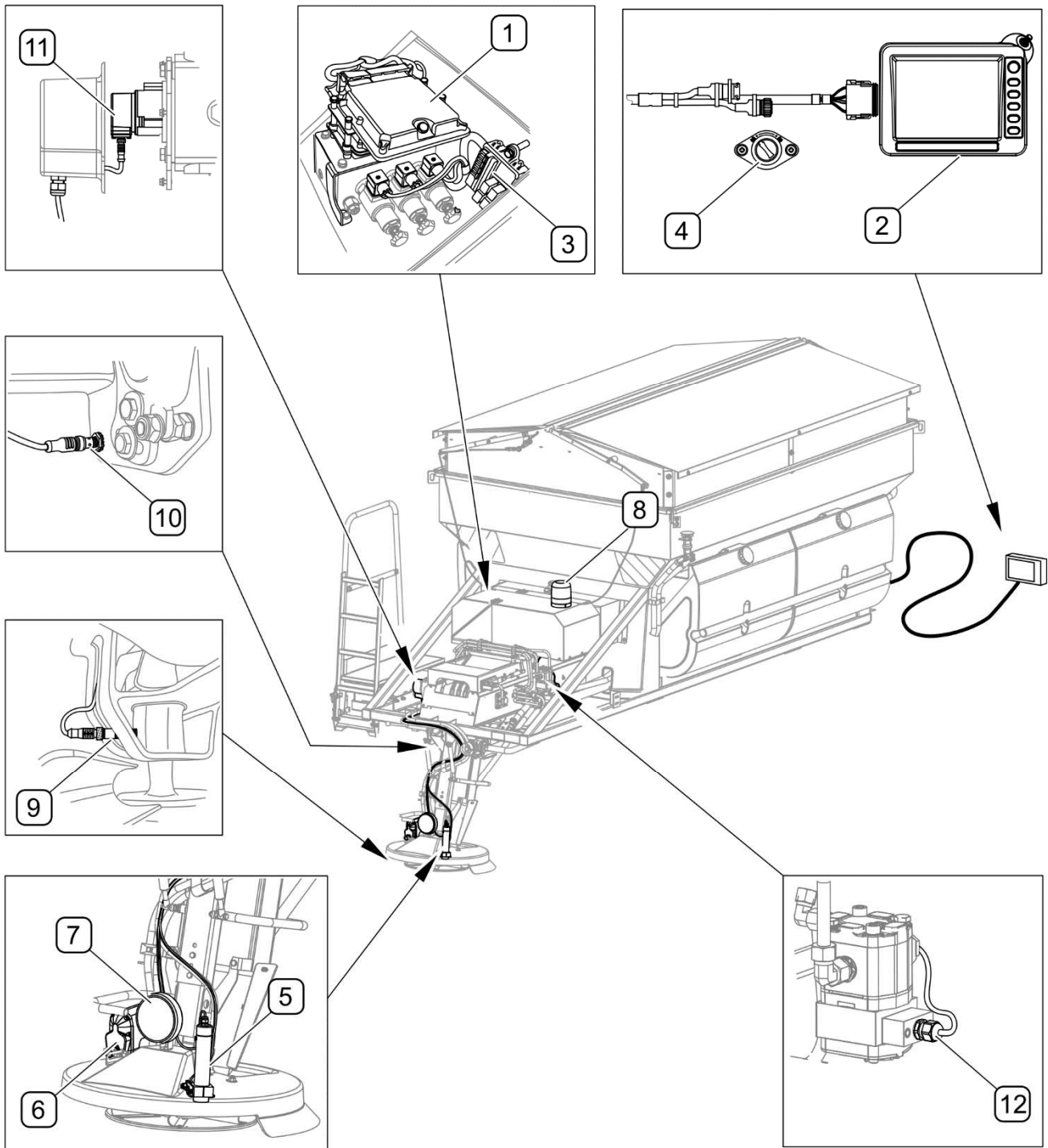

FIG. 3.6 Electrical system design

(1) - controller; (2) - control panel; (3) - fuses; (4) - main switch; (5) - spreading sensor; (6) - spreading direction adjusting cylinder; (7) - red rear lamp; (8) - beacon light; (9) - disk speed sensor; (10) - spreading mechanism rising sensor; (11) - belt speed sensor; (12) - brine pump speed sensor

SECTION

4

CORRECT USE

4.1 PREPARING FOR WORK BEFORE FIRST USE

DANGER



Before using the machine, the user must carefully read this Operator's Manual.

Careless and improper use and operation of the machine, and non-compliance with the recommendations given in this Operator's Manual is dangerous to your health.

The machine must never be used by persons who are not authorised to drive carrying vehicle, including children and people under the influence of alcohol or other drugs.

Non-compliance with the safety rules of this Operator's Manual can be dangerous to the health and life of the operator and others.

Before starting the machine, make sure that there are no bystanders in the danger zone.

The manufacturer guarantees that the machine is fully operational and has been checked according to quality control procedures and is ready for use. This does not release the user from an obligation to check the machine's condition after delivery and before first use. The machine is delivered to the user completely assembled.

Prior to connecting to carrying vehicle, machine operator must verify the sand spreader's technical condition, prepare it for first use and configure as needed. In order to do this:

- the user must carefully read this Operator's Manual and observe all recommendations, understand the design and the principle of machine operation
- Inspect sand spreader's individual components for mechanical damage resulting from incorrect transport (dents, piercing, bent or broken components),
- check the condition of protective paint coat,
- check all the lubrication points, lubricate the machine as needed according to recommendations provided in section 5,
- check all nut and bolt connections,
- check if spreading discs and blades are correctly installed,
- check tension of conveyor belt

**ATTENTION!**

Non-adherence to the recommendations stated in the Operator's Manual or improper use may cause damage to the machine.

The technical condition before starting the machine must be no cause for concern.

If all the above checks have been performed and there is no doubt as to the machine's good technical condition, it can be connected to carrying vehicle, started and all its individual systems checked. In order to do this:

- connect the machine to carrying vehicle (see „4.3 MACHINE INSTALLATION”),
- check correct operation of electrical system,
- check tightness and operation of hydraulic system,
- check operation of hopper system and spreading system,

In the event of a disruption in the operation of the machine immediately discontinue its use, locate and remove the fault. If a fault cannot be rectified or the repair could void the warranty, please contact the Manufacturer for additional clarifications.

**ATTENTION!**

Before using the machine always check its technical condition.

The machine must not be used when not in working order.

4.2 CHECKING TECHNICAL CONDITION

When preparing the machine for normal use, check individual elements according to the schedule (TAB. 4.1)

TAB. 4.1 TECHNICAL INSPECTION SCHEDULE

DESCRIPTION	SERVICE OPERATION	FREQUENCY
Technical condition of safety guards	Check technical condition of safety guards, if complete and correctly mounted.	Before beginning work
Technical condition of belt conveyor and spreading disc	Check the technical condition, if elements are complete and correctly mounted	
Technical condition of the hydraulic system.	Visually inspect the technical condition, check the tightness.	
Technical condition and operation of lamps and indicator lights	Visually inspect the technical condition, check operation after connecting to the carrying vehicle.	
Removing material accumulated under conveyor belt	Check and possibly remove material accumulated near tightening roller and on the internal surface of conveyor belt.	Every day after finishing work
Check the conveyor belt guidance.	Check the conveyor belt guidance.	Every day
Inspection of conveyor belt	Check tension and confirm that conveyor belt runs smoothly on drive roller and tightening roller. Check setting and condition of collecting brushes.	Once a month
Brine strainer cleaning	Clean brine strainer according to section „5.4 MAINTENANCE OF BRINE SPRAY SYSTEM”	Once a month
Tightening of all main nut and bolt connections	Torque values should be according to table (5.7)	Once a week
Lubrication	Lubricate elements according to section 5.7 LUBRICATION.	According to table (5.4)



ATTENTION!

Before filling the brine tank check and if necessary tighten the screws that mount the tank to the frame

4.3 MACHINE INSTALLATION

4.3.1 INSTALLING THE MACHINE ON THE CARRYING VEHICLE'S LOAD PLATFORM



DANGER

When hitching, there must be nobody under and between the machine and the carrying vehicle.

Exercise caution when hitching the machine to carrying vehicle.

The sand spreader can be installed on the carrying vehicle that meets the requirements contained in Table 1.1 *CARRYING VEHICLE REQUIREMENTS*.



ATTENTION!

Before hitching the sand spreader to carrying vehicle, read the carrying vehicle operator's manual.



ATTENTION!

Before installing the machine on the carrying vehicle, remove snow, ice and other contaminants from the load platform.

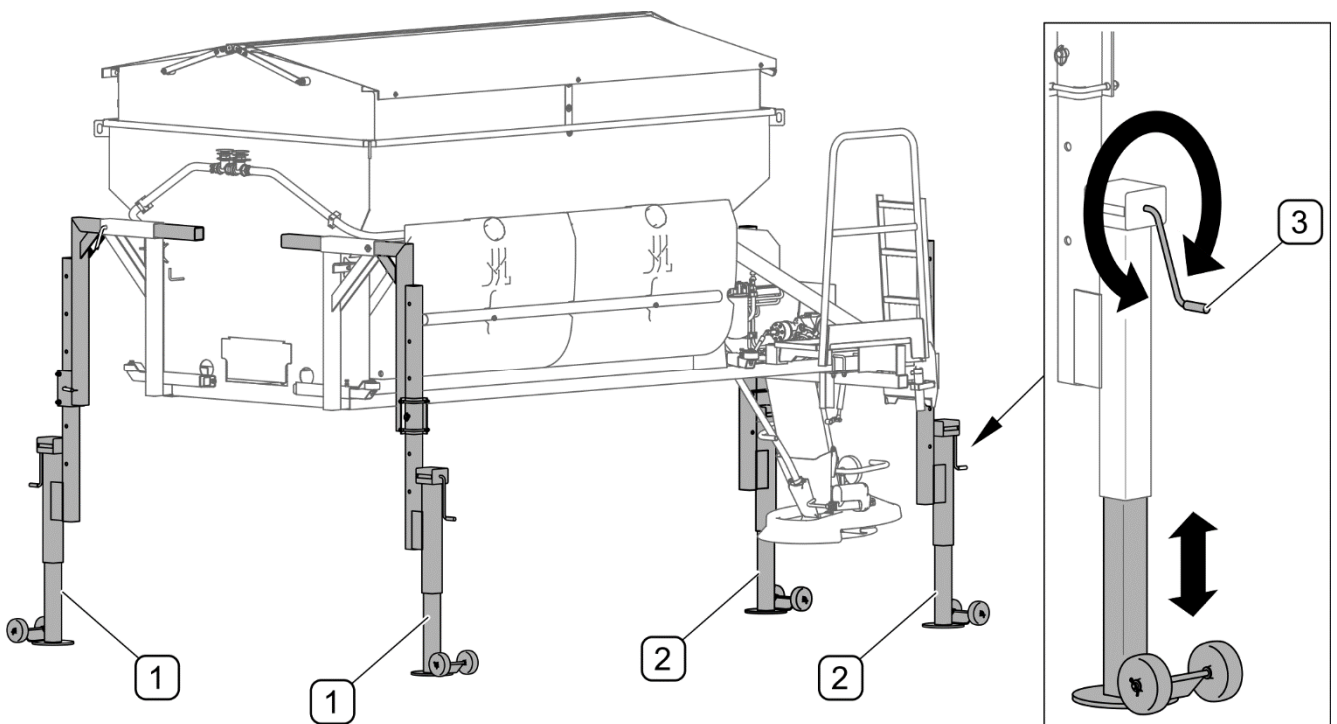

FIG. 4.1 Parking stands (option)

(1) - front parking stand; (2) - rear parking stand; (3) - height adjustment mechanism

If the sand spreader is equipped with adjustable parking stands (FIG. 4.1), adjust the stands properly depending on the height of the carrying vehicle's load platform. Adjustments can be made using crank mechanism (3).

Position setting is facilitated by adjustable guides (1) and (2) with wheels (FIG. 4.2) and limiters attached to the bottom of frame beam in the rear section of the machine. Set the front (1) and rear (2) guides in such a manner as to ensure that dimension (A) is slightly smaller than internal width of the carrying vehicle's load platform (FIG. 4.2)

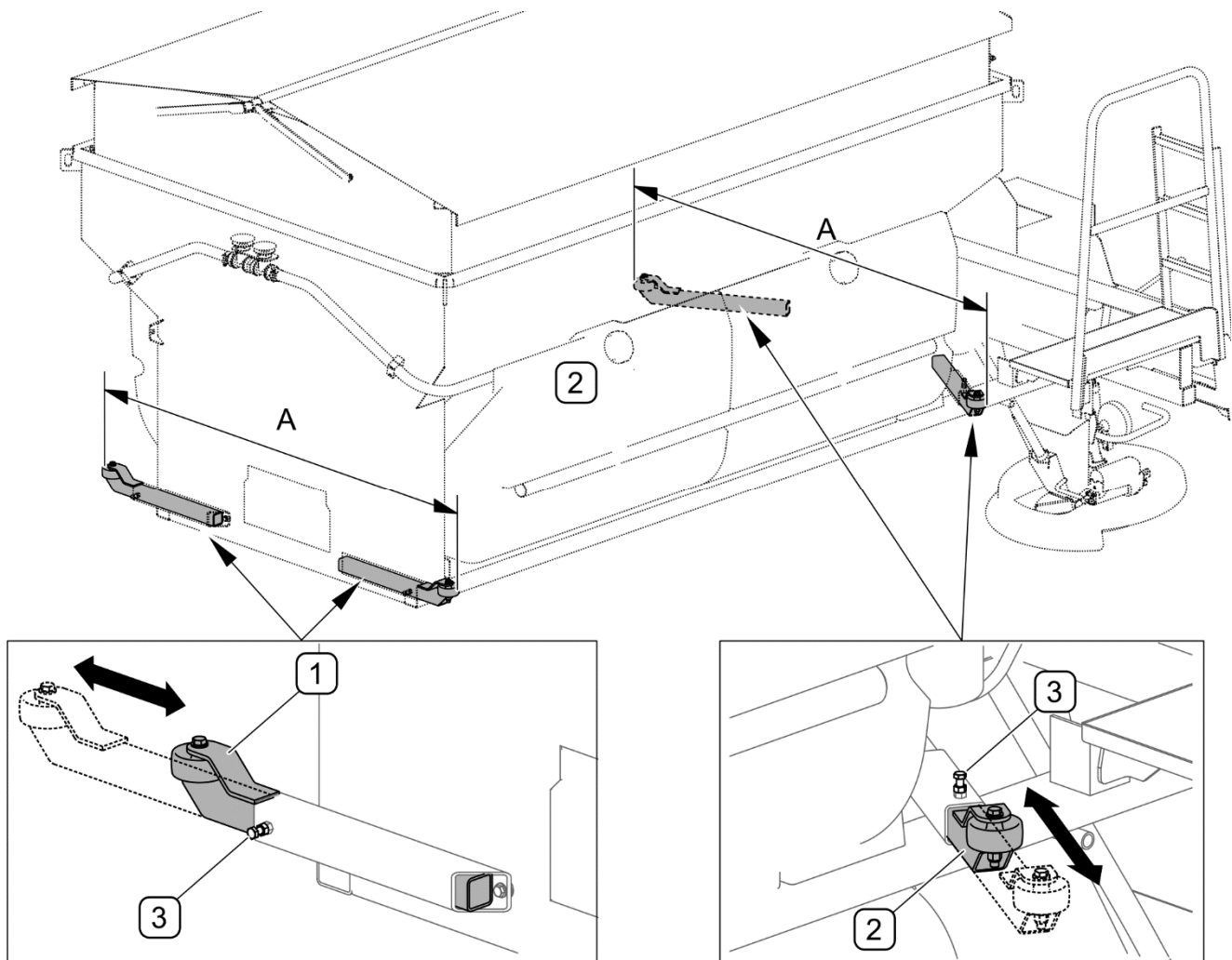

FIG. 4.2 Guides

(1) - front guide; (2) - rear guide; (3) - set screw

TIP



Guides (FIG. 4.2) are used in carrying vehicles which have sufficiently strong side walls of the load platform.

The use of guides (FIG. 4.2) depends on the method of fixing the machine on load platform (see 4.3.2 SECURING THE MACHINE TO THE CARRYING VEHICLE'S LOAD PLATFORM)

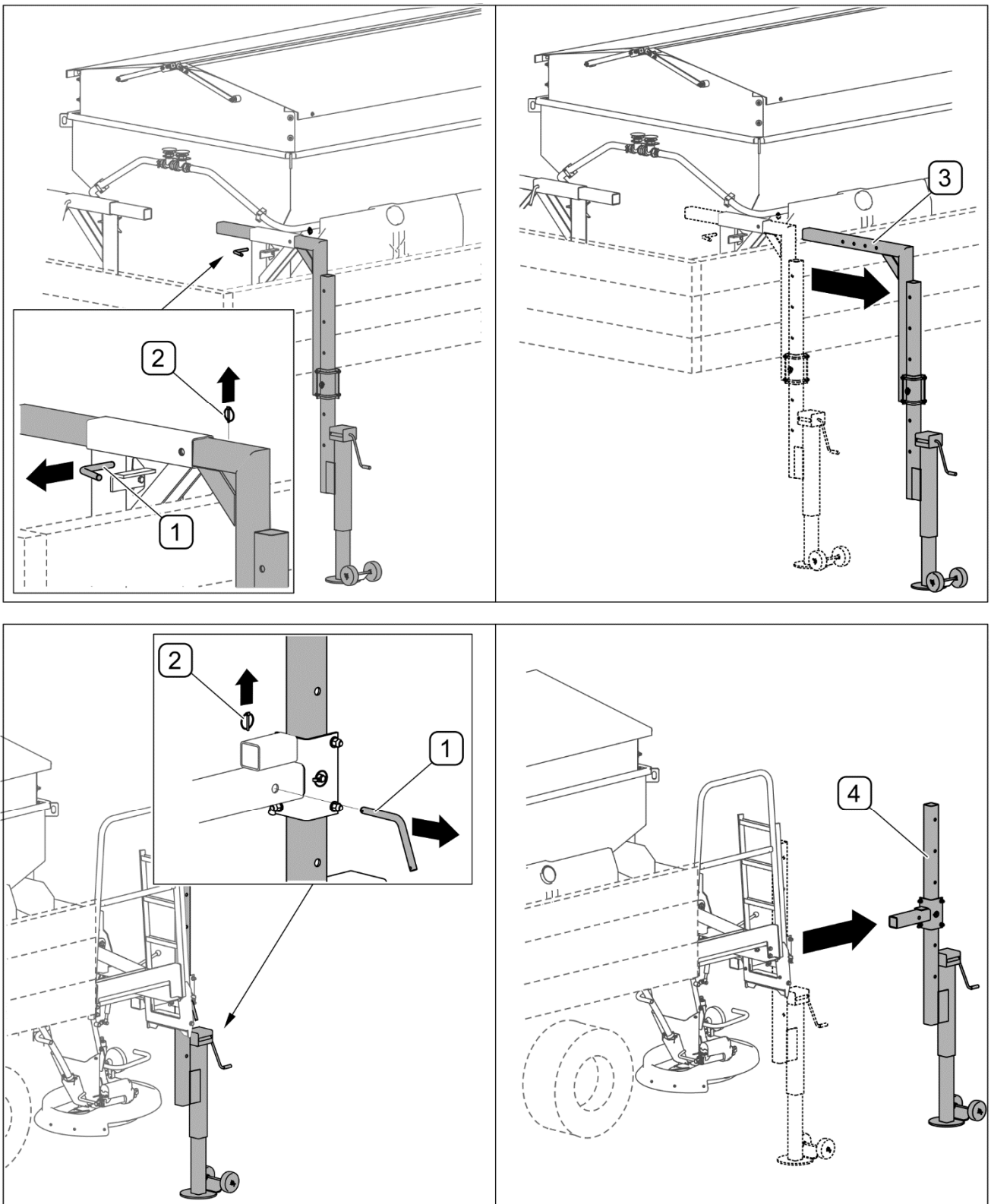

FIG. 4.3 Dismantling the parking stands

(1) - pin; (2) - linchpin; (3) - front parking stand; (4) - rear parking stand

Reverse the carrying vehicle and position the load platform so as to ensure that the sand spreader is positioned symmetrically with regard to the right side and the left side of the load platform. Make sure that the limiters on the bottom of the sand spreader frame are supported on the rear edge of the load platform.

Dismantle the parking stands when the load platform is positioned properly with regard to the sand spreader. In order to do this:

- Lower the machine onto the carrying vehicle's load platform by rising successively the parking stands by means of height adjustment mechanism (3) (FIG. 4.1).
- When the machine is fully supported on the load platform, remove linchpins (2) and pins (1) that secure stands in guides (FIG. 4.3).
- Dismantle front stands (3) and rear stands (4) and keep them for further use.

4.3.2 SECURING THE MACHINE TO THE CARRYING VEHICLE'S LOAD PLATFORM



DANGER

DO NOT use the machine if it is not properly secured to the carrying vehicle's load platform.

Secure the machine according to the rules for securing loads on vehicles moving on public roads.

The machine positioned on the carrying vehicle should be secured to load platform by means of fastening straps certified according to EN 12195-2 standard and fitted with a tightening mechanism. The sand spreader is fitted with eight attachment points for fastening straps (FIG. 4.4). In order to correctly secure the sand spreader, the carrying vehicle's load platform must be fitted with attachment points for fastening straps. Otherwise, install such points in a proper manner.

Permissible load of fastening straps and method of their attachment depend on a selected method of securing the machine to the carrying vehicle's load platform.



IMPORTANT

Install fastening straps in such a manner as to protect them against damage caused by sharp edges of the machine or carrying vehicle.

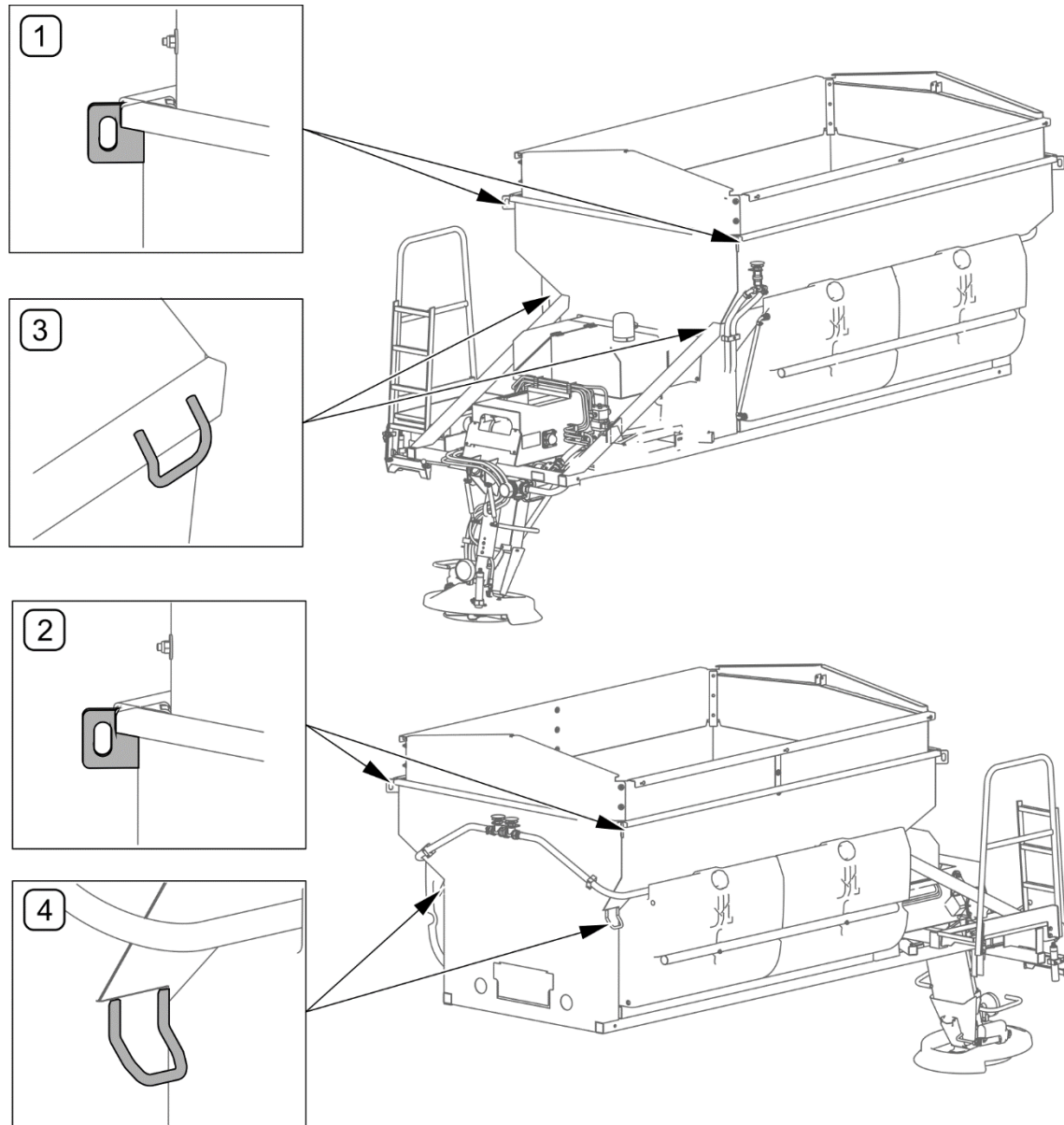

FIG. 4.4 Attachment points for fastening straps

(1) - rear, upper attachment points; (2) - front, upper attachment points; (3) - rear, lower attachment points; (4) - front, lower attachment points;



ATTENTION!

Fastening strap may be used only if it is not damaged and has a legible label with a proper certificate according to EN-12195-2

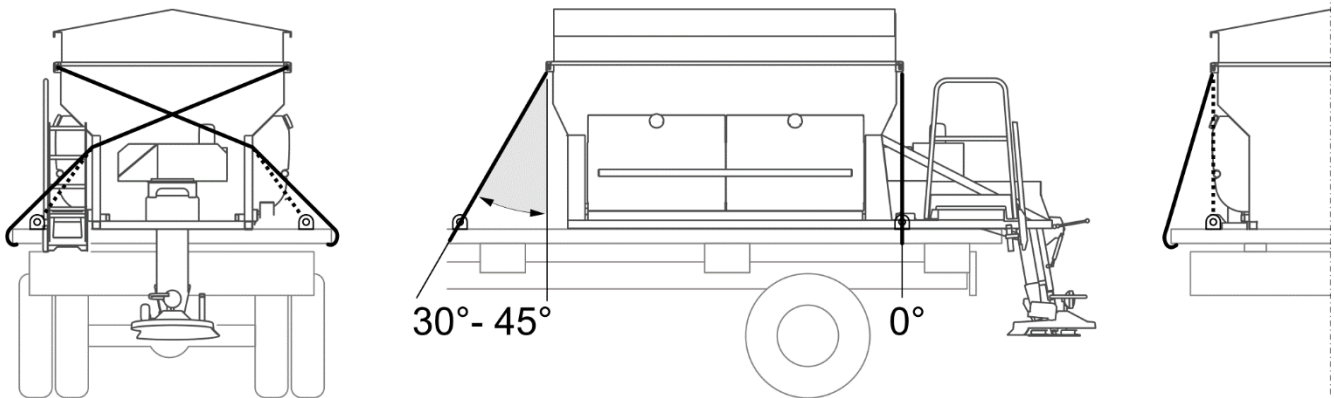

FIG. 4.5 Securing method 1

Securing method 1 (FIG. 4.5) is used in case of carrying vehicles with weak or without side walls of load platform. To secure the machine, use 4 LC 2 000 daN fastening straps according to EN 12195-2 standard and attach them to special catches on the load platform or to the load platform side.

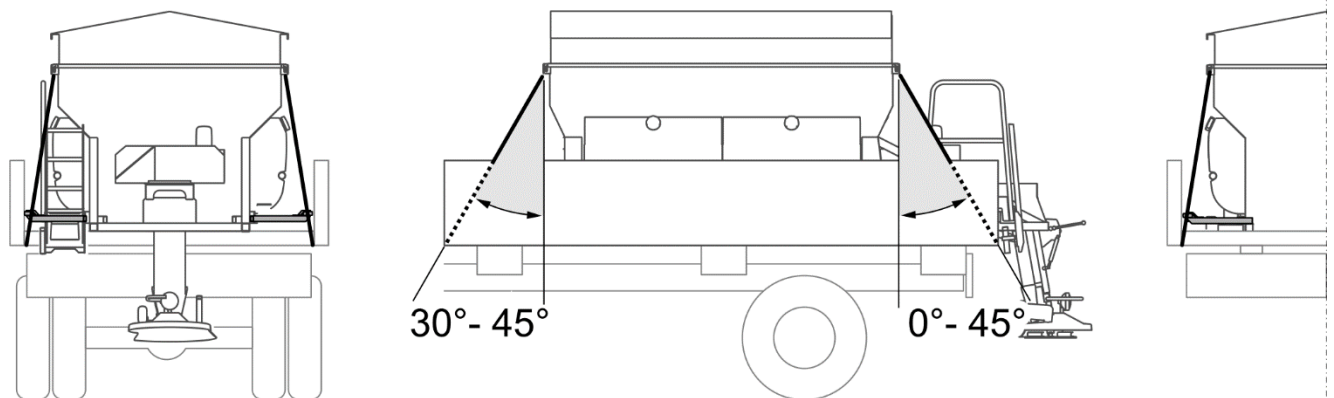

FIG. 4.6 Securing method 2

Securing method 2 (FIG. 4.6) is used in case of carrying vehicles with strengthened side walls of load platform. To secure the machine, use 4 LC 2 000 daN fastening straps according to EN 12195-2 standard and attach them to the load platform side.

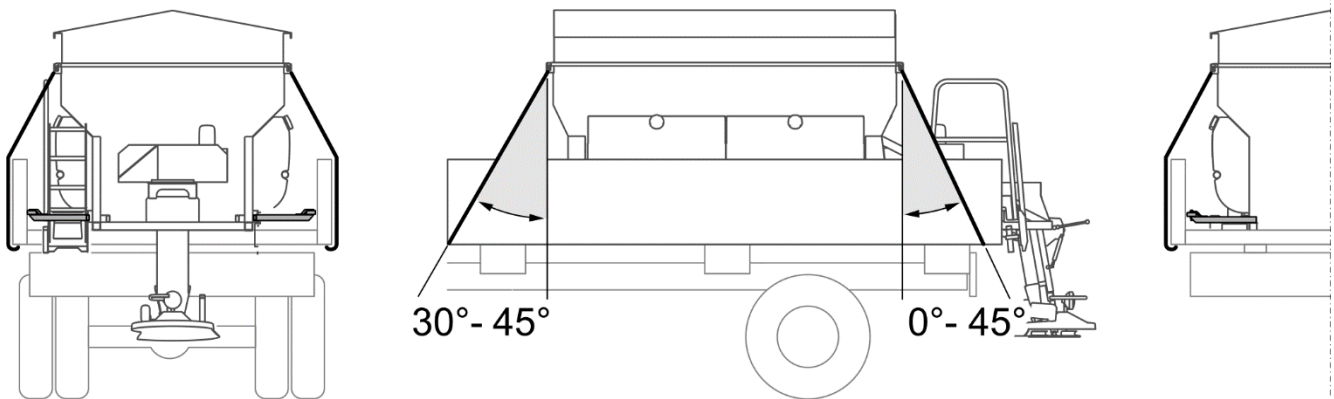

FIG. 4.7 Securing method 3

Securing method 3 (FIG. 4.7) is used in case of carrying vehicles with strengthened side walls of load platform. To secure the machine, use 4 LC 2 000 daN fastening straps according to EN 12195-2 standard.

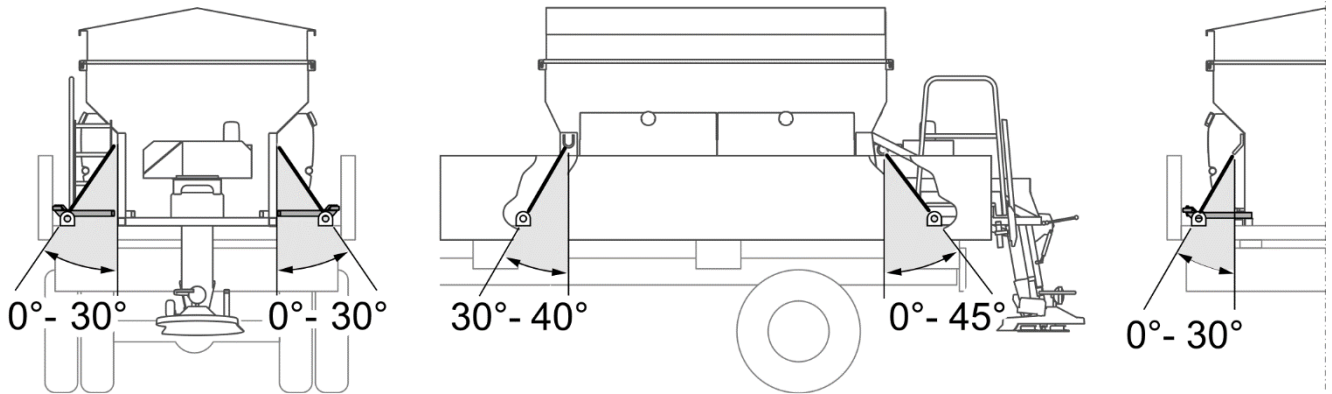

FIG. 4.8 Securing method 4

Securing method 4 (FIG. 4.8) is used in case of carrying vehicles with weak or without side walls of load platform. To secure the machine, use 4 LC 2 000 daN fastening straps according to EN 12195-2 standard and attach them to special catches on the load platform.

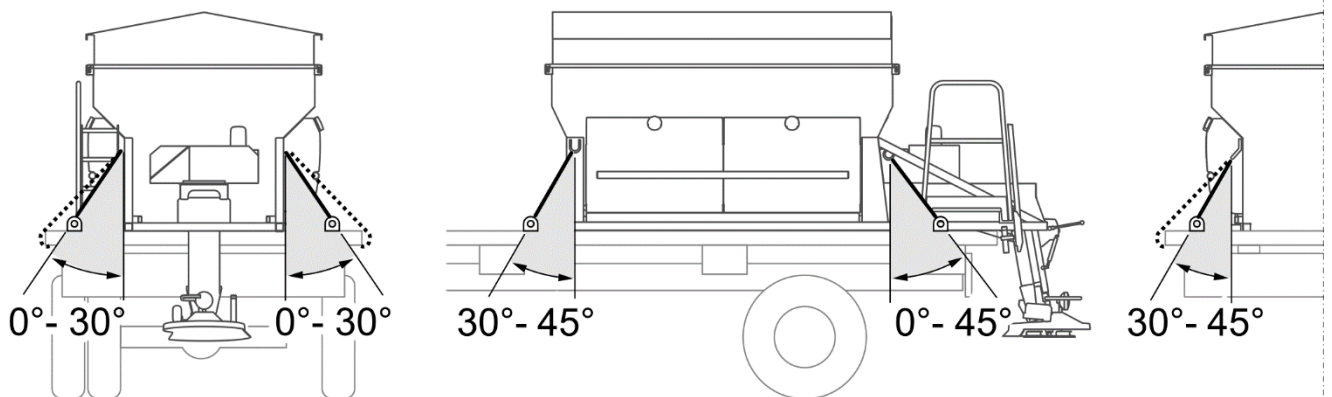

FIG. 4.9 Securing method 5

Securing method 5 (FIG. 4.9) is used in case of carrying vehicles with no side walls of load platform. To secure the machine, use 4 LC 2 000 daN fastening straps according to EN 12195-2 standard and attach them to special catches on the load platform or to the load platform side.



DANGER

If the carrying vehicle's load platform has "tipper" function, switch this function off or lock to prevent accidental use.

4.3.3 CONNECTING CONTROL ELECTRICAL SYSTEM

When connecting the sand spreader to carrying vehicle electrical system:

- Connect control panel's wiring harness with switch to control panel and place the complete set in the operator cab in an accessible place.
- Connect control panel's wiring harness with sand spreader's wiring harness through electrical connection.
- Connect supply leads of sand spreader's wiring harness to carrying vehicle's battery (24V). Connect red lead to the positive end of the vehicle's battery (+) and black lead to the negative battery end (-).

To ensure correct operation of the sand spreader's control system, the carrying vehicle should be equipped with a connection with travel speed pulse input according to ISO 16844-2.



DANGER

Prior to connecting individual system lines the user must carefully read the carrying vehicle operator's manual and observe all Manufacturer's recommendations.



ATTENTION!

During operation, the connecting cables should be routed so that they do not get entangled in moving machine and carrying vehicle parts.

4.3.4 CONNECTING HYDRAULIC SYSTEM

The sand spreader is designed for connecting with the external hydraulic system of the carrying vehicle. Depending on the machine version, the sand spreader can be equipped with permanent hydraulic connections or hydraulic connections installed on hydraulic conduits (optional equipment).

Supply line should be connected to hydraulic socket (1) while plug (2) should be connected to oil return line to the carrying vehicle's hydraulic system (FIG. 4.10).



DANGER

Reduce pressure in the system prior to connecting the machine to the hydraulic system.

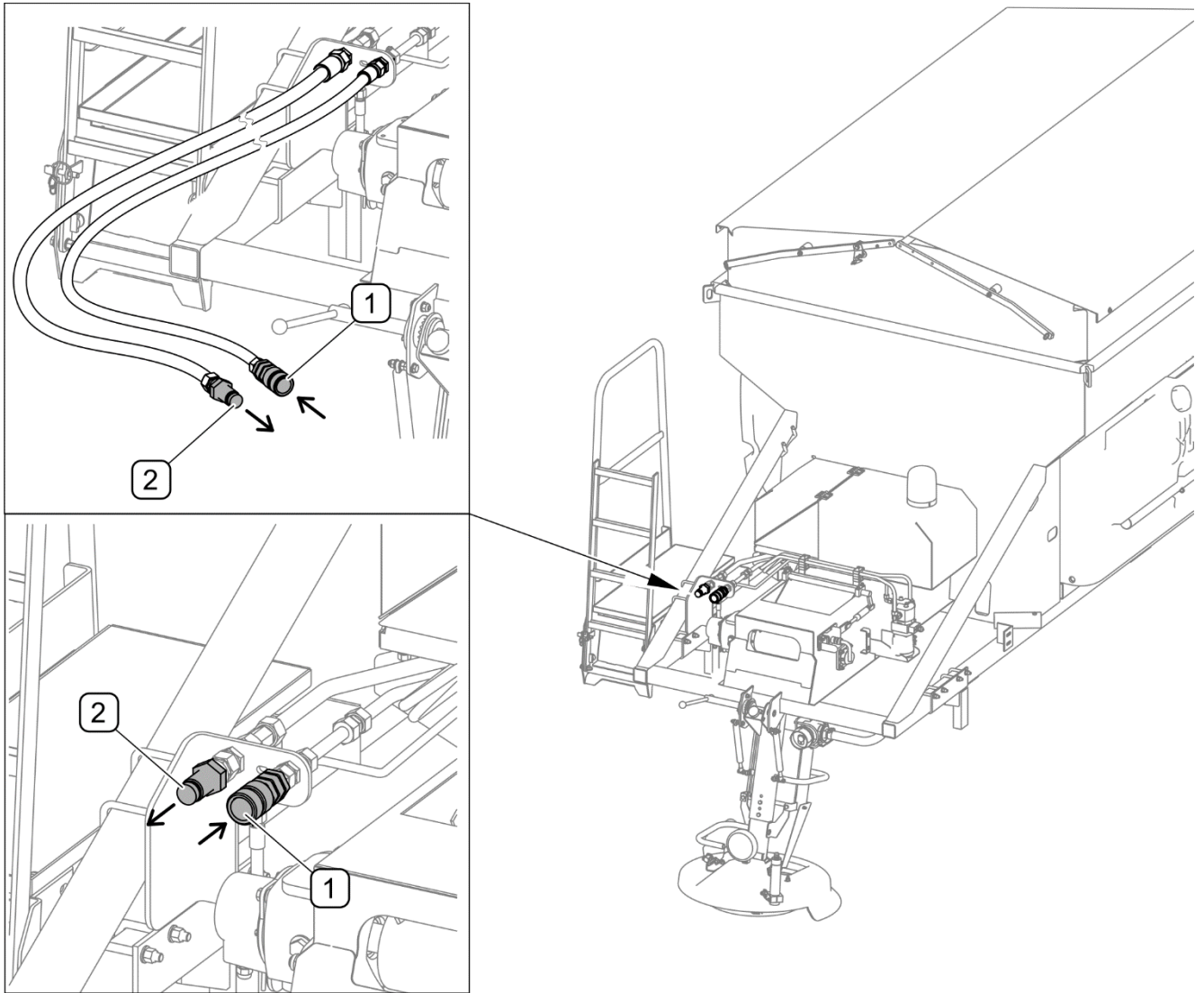

FIG. 4.10 **Connecting hydraulic system**

(1) - oil supply hydraulic socket; (2) - hydraulic plug of oil return to the carrying vehicle



TIP

After connecting the spreader, check the oil level in the external hydraulic system of the carrying vehicle.

4.4 PREPARING FOR WORK

4.4.1 SETTING THE SPREADING MECHANISM



DANGER

The spreading mechanism may be lowered, raised and set in any manner only when the machine installed on the carrying vehicle's load platform is switched off.

Before starting work, set the spreading mechanism in a proper manner. Adjustments are made after installing the machine on the carrying vehicle.

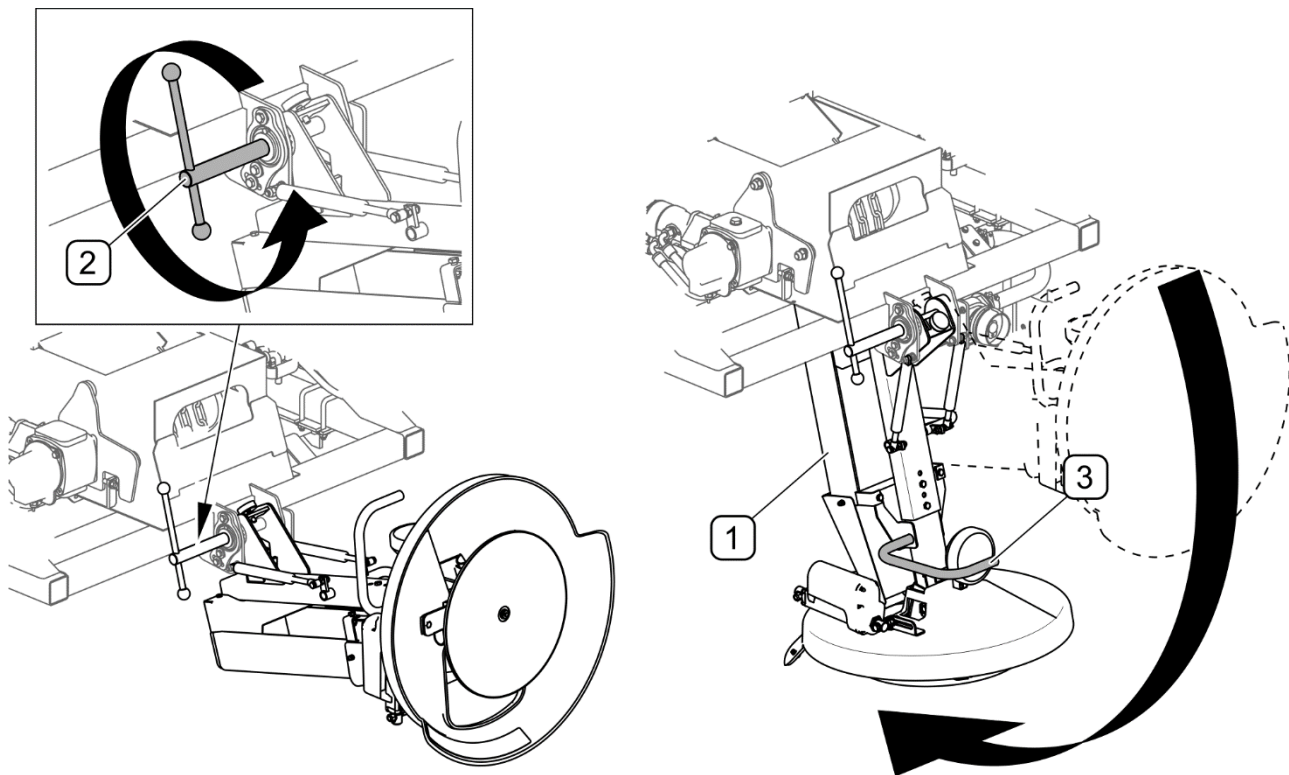

FIG. 4.11 Lowering the spreading mechanism

(1) - spreading mechanism; (2) - clamp bolt; (3) - grip

Lower the spreading mechanism (FIG. 4.11) to working position:

- loosen clamp bolt (2),
- lower the mechanism while holding grip (3),
- tighten clamp bolt (2).

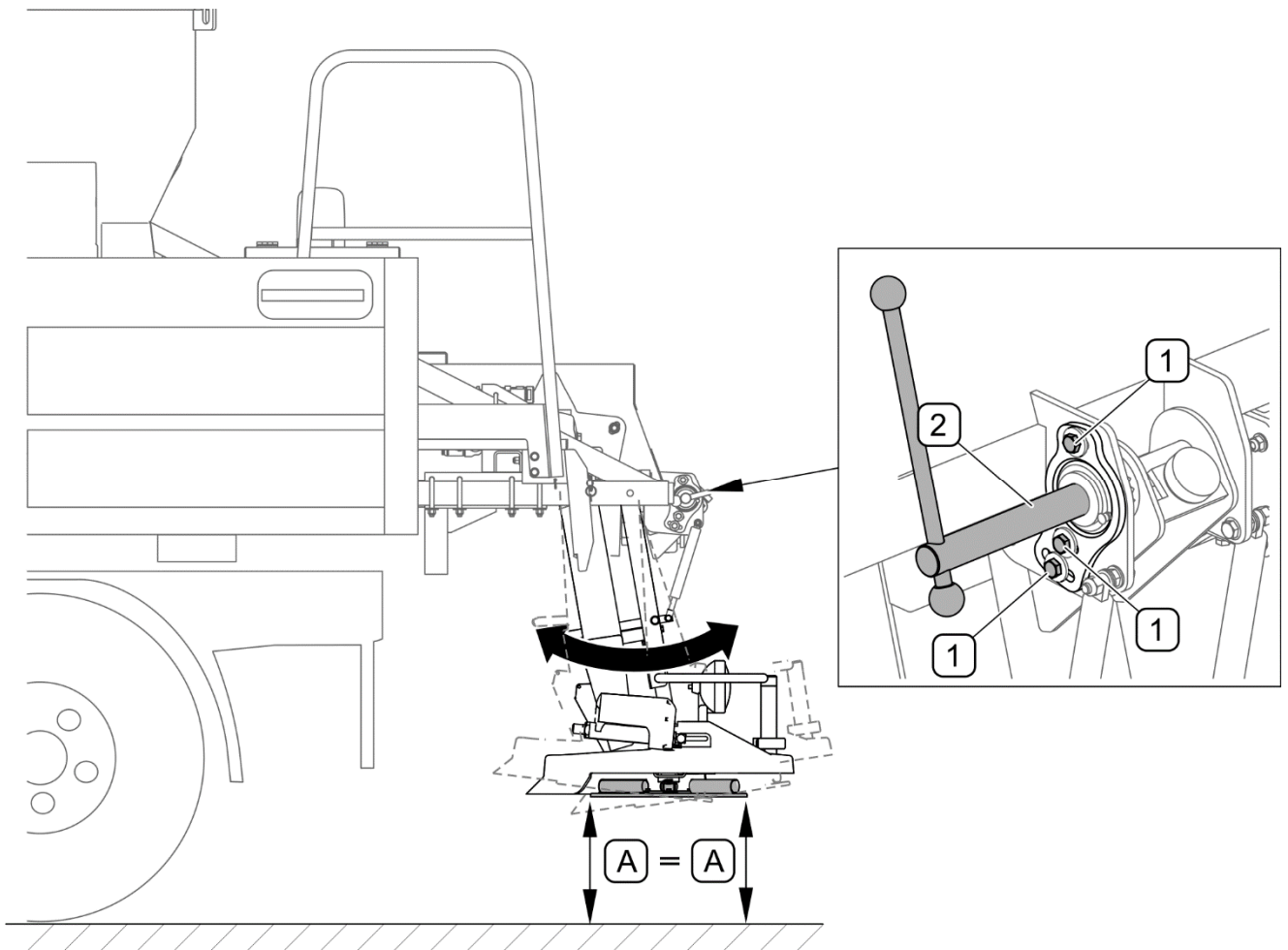

FIG. 4.12 **Levelling the spreading disc**

(1) - M10x35 bolt; (2) - clamp bolt

During operation, the spreading disc should be levelled. To check that the spreading disc is level, measure the distances between the disc and the ground in two extreme points (A) to confirm that the distances are the same (FIG. 4.12). Otherwise, make adjustment as follows:

- check that clamp bolt (2) is tightened,
- loosen three bolts (1),
- shift the spreading mechanism forwards or backwards in order to set the spreading disc in such a manner that distances (A) are the same,
- tighten bolts (1).

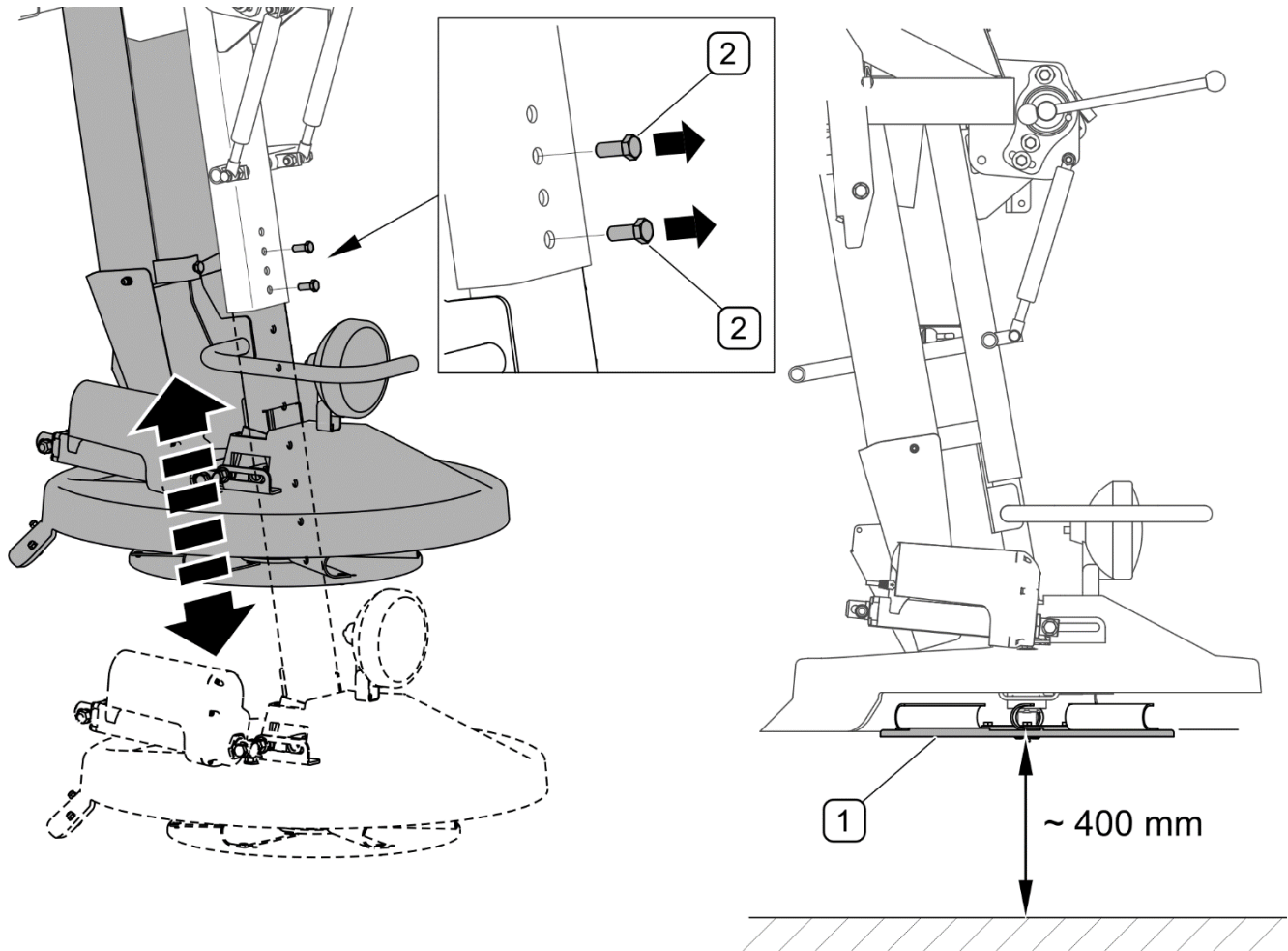

FIG. 4.13 **Setting the distance between the spreading disc and road surface**

(1) - spreading disc; (2) - M10x25 bolt

After levelling the spreading disc, check its height above the road surface. After lowering of the spreading mechanism, correctly set spreading disc should be located at the height of 400 ± 15 mm above road surface (FIG. 4.13).

To set the distance between the spreading disc and road surface (FIG. 4.13):

- unscrew two bolts (2) while holding the spreading mechanism,
- set the spreading mechanism so as to ensure that the distance between spreading disc (1) and road surface is approximately 400 ± 15 mm,
- screw bolts (2) into proper holes of the guide.

The distance between the spreading disc and road surface is recommended to be checked again after loading the tank and filling the tank with brine. Please note that spreading width depends on the height of spreading disc above the road surface.

4.5 LOADING THE MACHINE

4.5.1 LOADING THE TANK



DANGER

Loading may be performed only if the sand spreader is switched off and mounted on the carrying vehicle's load platform. Be especially careful when loading the machine.

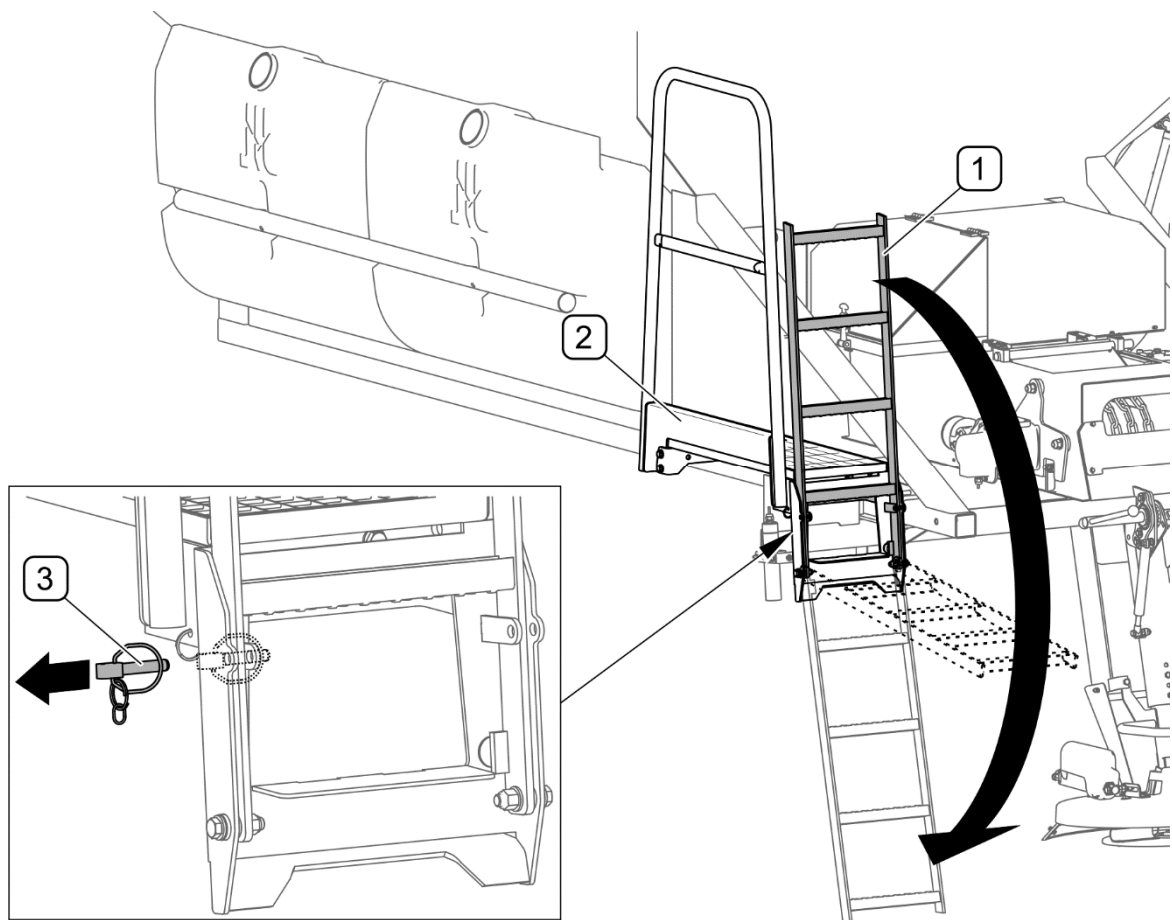

FIG. 4.14 Ladder and platform

(1) - ladder; (2) - platform; (3) - securing cotter pin

The platform (FIG. 4.14) fitted with ladder (1) facilitates raising and lowering of tarpaulin cover.

To lower the ladder (FIG. 4.14):

- hold the ladder (1) and remove securing cotter pin (3),
- lower the ladder (1).

Release catch (3) by pulling a cord and raise tarpaulin cover by means of frame lever. Tarpaulin cover rising sequence (I) - (II) is shown in (FIG. 4.15).

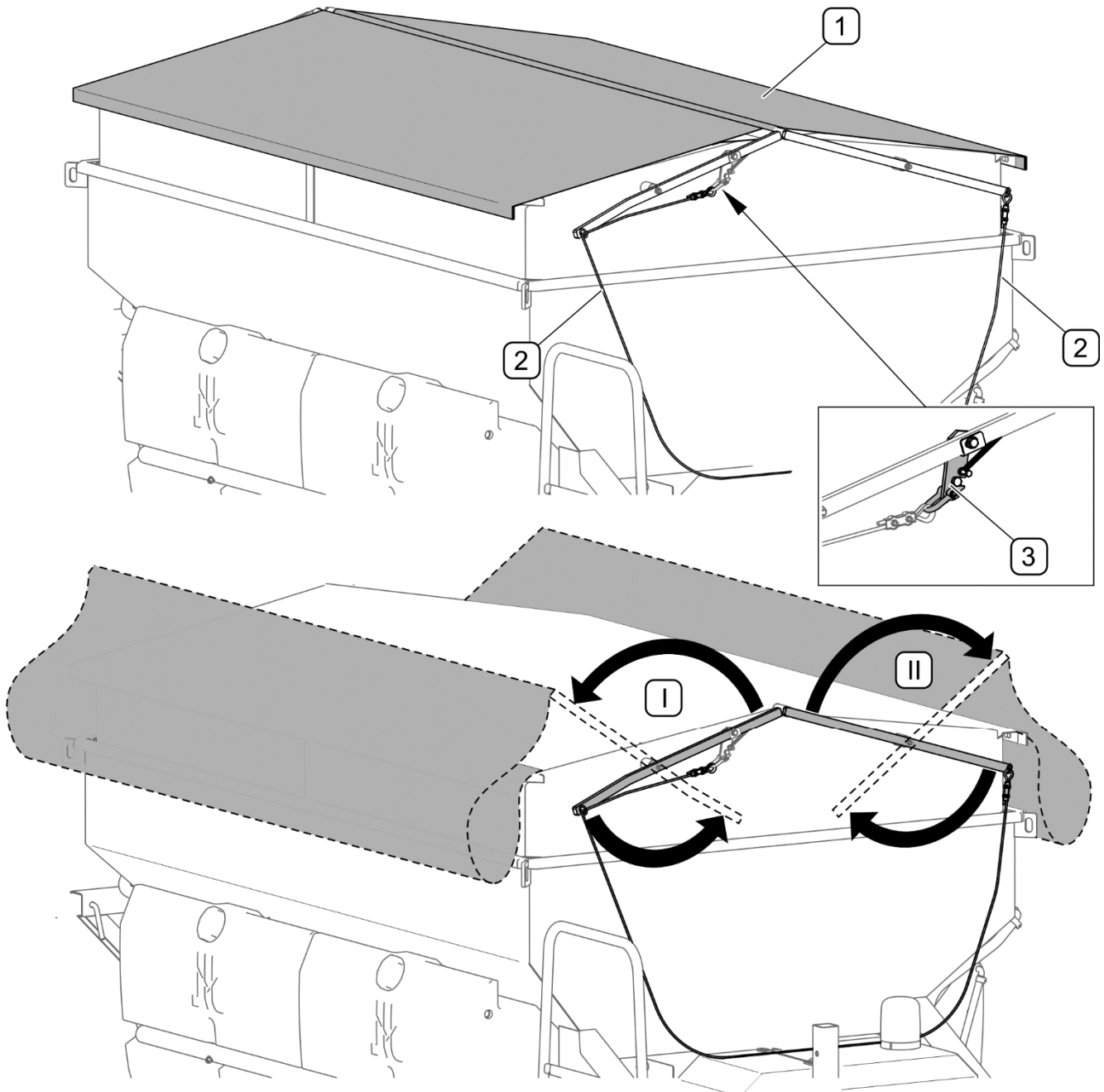

FIG. 4.15 Raising the tank's tarpaulin cover

(1) - tarpaulin cover; (2) - catch; (3) - frame lever

Before loading, check that there are no foreign objects (tools, stones etc.) in the tank. The tank should be loaded from above through the screen that prevents lumps of material from entering the tank. When loading the tank, it is recommended to use a front loader or belt conveyor. Efforts should be made to evenly distribute the load in the tank in order to ensure proper stability of the sand spreader. Avoid throwing material into the tank from a great height. After loading, cover the tank with tarpaulin (FIG. 4.15) and make sure that the pawl (2) is locked.

**ATTENTION!**

Spreading agents must be prepared in accordance with the regulations concerning winter road maintenance in force in the country in which the sand spreader is used. Spreading agents other than those recommended by the Manufacturer must not be used.

4.5.2 FILLING THE TANK WITH BRINE**DANGER**

Filling the tanks with brine should be performed only if the sand spreader is switched off and mounted on the carrying vehicle's load platform. Be especially careful when filling the tanks.

The tanks can be filled with brine (FIG. 4.16) through tank openings secured with plugs (1) or through STORZ 52C connection (2) secured with a plug (3).

In order to fill the tanks with brine (FIG. 4.16) through connection (2):

- set valve lever (4) in position (B),
- unscrew plug (3) and connect filling hose to connection (2),
- set valve lever (4) in position (A) and start filling,
- brine level is checked on brine level indicator (5) located on the tank,
- when filling is completed, set lever (4) to position (B),
- disconnect filling hose and tighten plug (3).

To fill the tanks directly through filler opening, unscrew plug (1) and insert filling hose to filler opening. It is enough to fill one tank only, because all tanks are connected. When filling is completed, tighten the tank plug.

**TIP**

If filling with brine is performed too quickly, the tank to which brine is poured directly may be filled faster than the other tanks. In such a case, stop filling and wait until level of liquid in all tanks is the same.

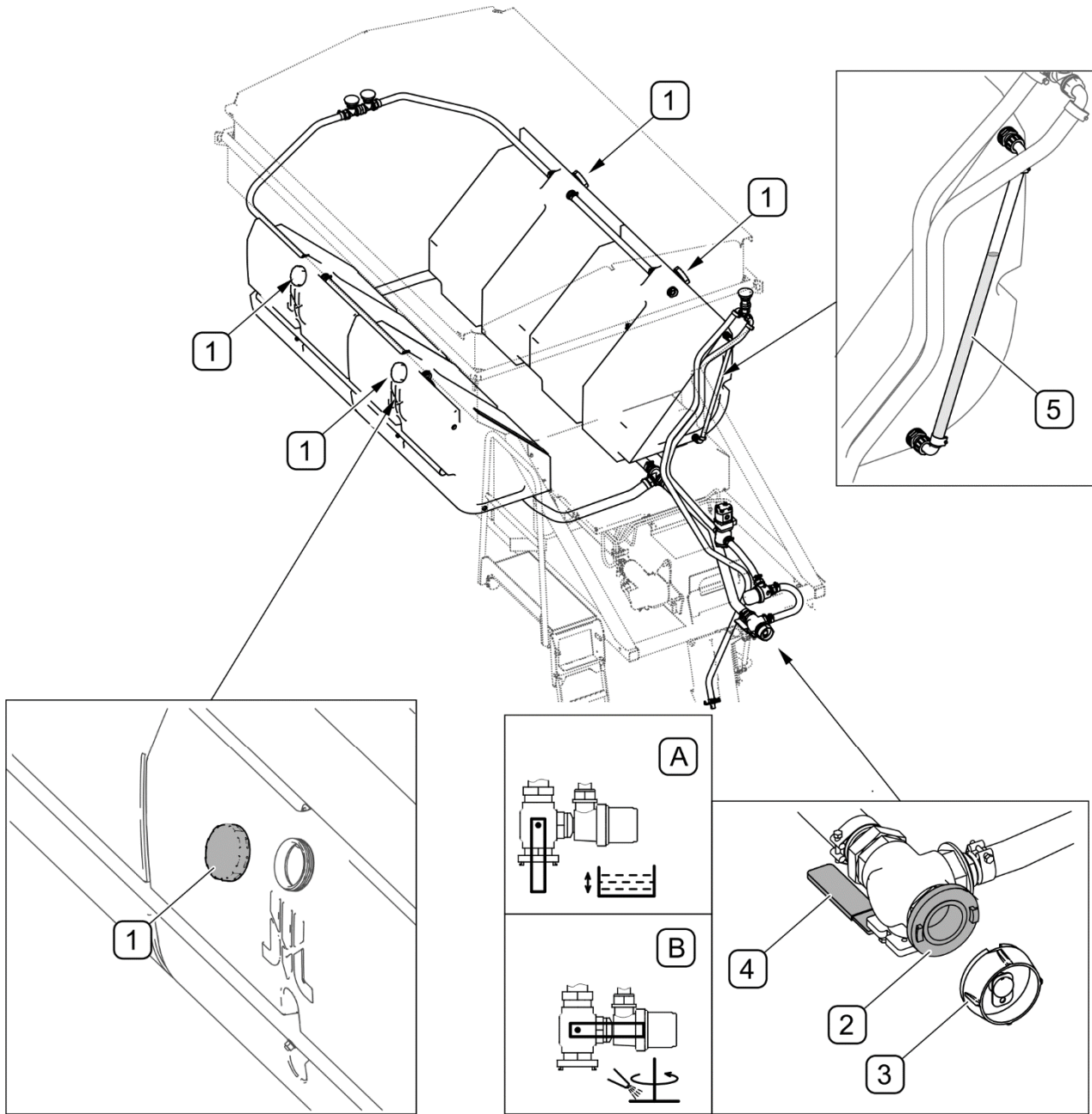

FIG. 4.16 Filling the tank with brine

(1) - tank plug; (2) - STORZ 52C valve connection; (3) - valve plug; (4) - valve lever; (5) - brine level indicator; (A) - valve in position „filling/emptying”; B) - valve in position "brine spraying";

4.6 CONTROL PANEL

4.6.1 GENERAL DESIGN AND OPERATION

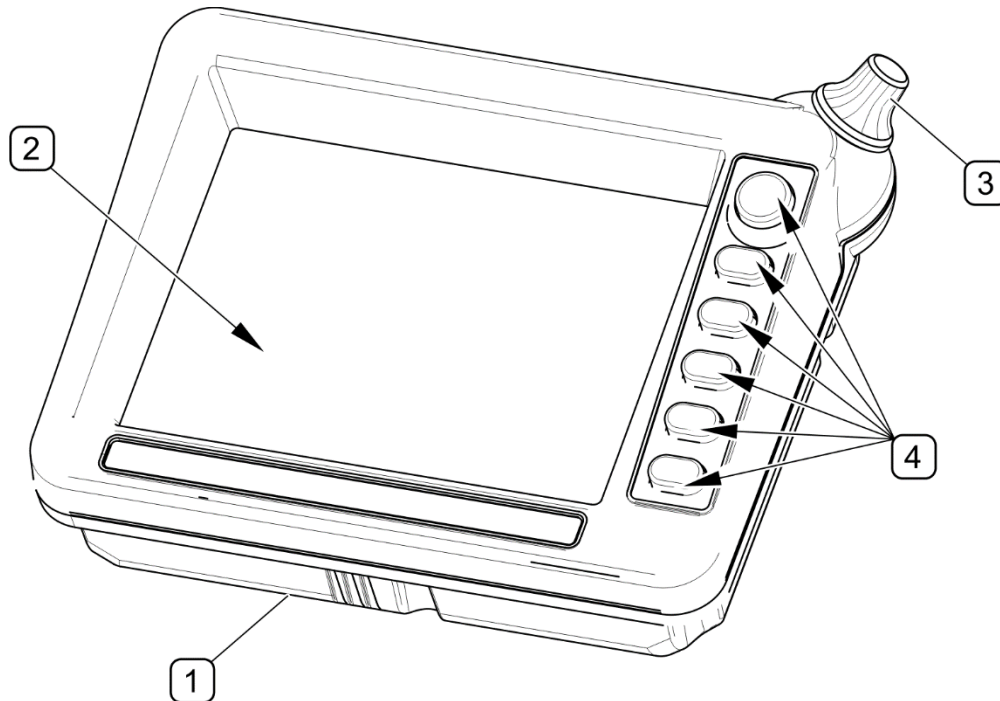

FIG. 4.17 General design of control panel

(1) - enclosure; (2) - LCD display ; (3) - parameter change knob; (4) - function push-buttons

Control panel (FIG. 4.17) consists of enclosure (1), colour LCD display (2), parameter change knob (3) and six function push-buttons (4).

Depending on a display menu page selected, (FIG. 4.18) currently assigned functions (B) are displayed next to function push-buttons (2),(3),(4),(5),(6),(7). On each display menu page, different functions are displayed for a given push-button. Empty function field next to push-buttons (3),(4),(6) means that the push-buttons are not active at the moment (FIG. 4.18). Knob (1) is used for moving to another field (C) and for changing values of parameters in field (D).

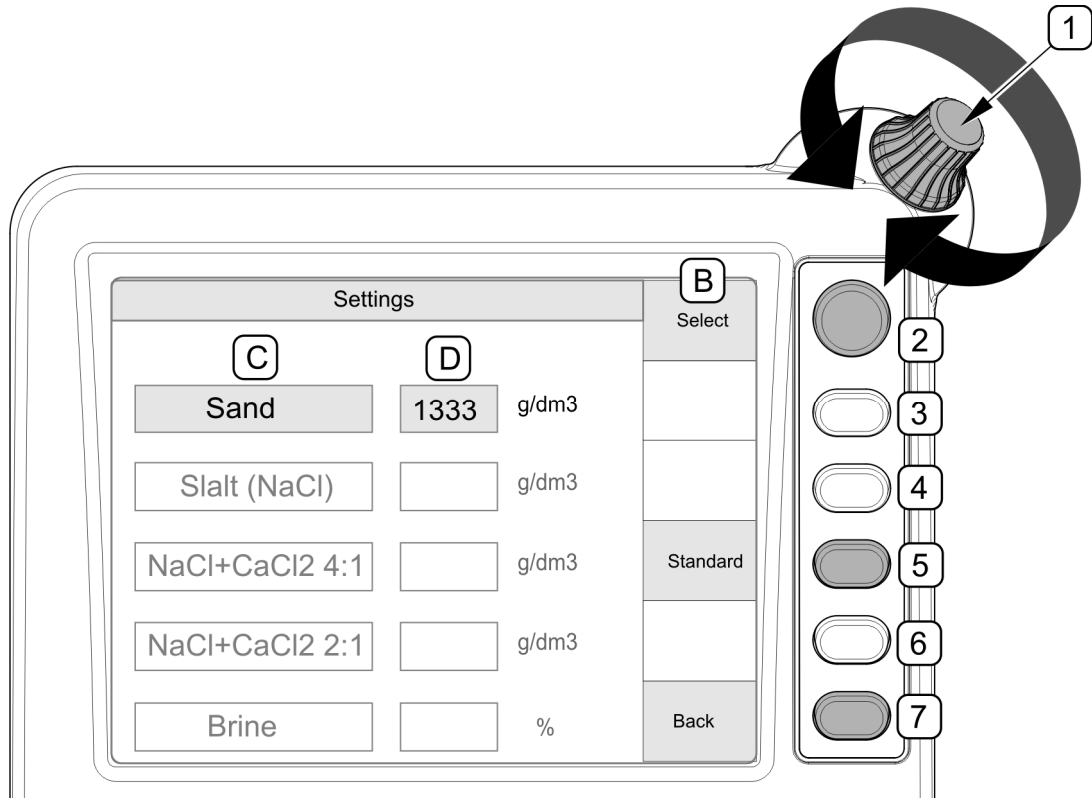

FIG. 4.18 Example of control panel operation

(1) - parameter change knob; (2), (3), (4),(5), (6), (7) - function push-buttons; (B) - push-button function; (C) - parameter name field; (D) - parameter value field

4.6.2 DESCRIPTION OF CONTROL PANEL MENU

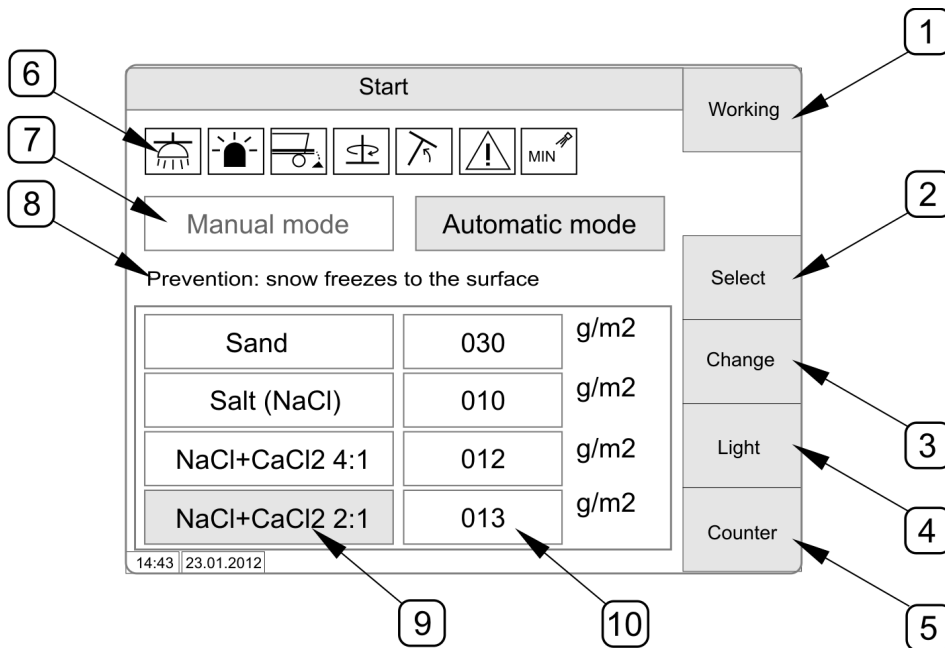

FIG. 4.19 Home page of control panel display

Description of home page functions is included in TAB. 4.2

TAB. 4.2 Description of functions on control panel home page

MARKING FIG. 4.19	FUNCTION NAME	DESCRIPTION
1	„Working”	Moving to working page
2	„Select”	Selecting a field for editing: - automatic mode / manual mode - selecting a spreading material
3	„Change”	Editing a selected field
4	„Light”	Turning on warning lights
5	„Counter”	Moving to counter page
6	-	Control icons
7	„Manual mode” „Automatic mode”	Manual or automatic working mode is active (option)
8	„Prevention.....”	One of the automatic working modes is active (option).
9	„NaCl+CaCl2 2:1”	Currently selected spreading material
10	"013 g/m2"	Preliminary setting of spreading density for a currently selected material

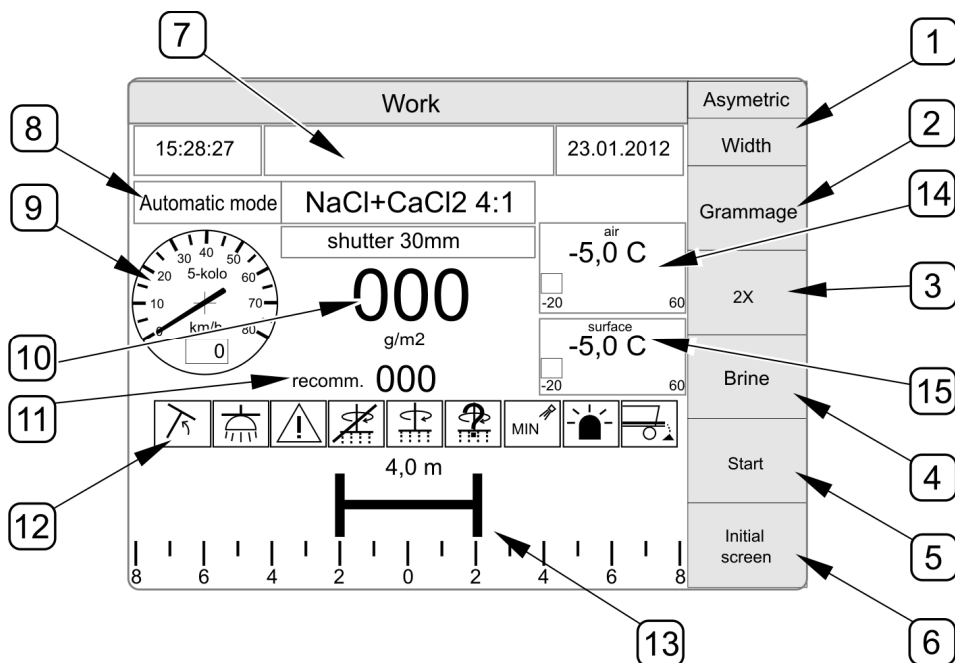

FIG. 4.20 Working page of control panel display

Description of working page functions is included in TAB. 4.3

TAB. 4.3 Description of functions on control panel working page

MARKING FIG. 4.20	FUNCTION NAME	DESCRIPTION
1	„Asymetric” „Width”	Editing of asymmetry and spreading width
2	„Grammage”	Editing of spreading density
3	"2X"	Double dose
4	„Brine”	Activation of brine spraying
5	"Start"	Activation of spreading
6	„Initial screen”	Moving to home page
7	-	Message window
8	„Automatic mode” „NaCl+CaCl ₂ 4:1” "shutter - 30mm"	Currently selected working conditions
9	"0 km/h"	Current working speed or speed simulation (available in service mode)
10	"000 g/m ² "	Defined density
11	"recomm. 000"	Recommended density in automatic mode
12	-	Control icons
13	"4 m"	Spreading pattern (width and asymmetry)
14	"air -5,0 C"	Air temperature (option)
15	"surface -5,0C"	Road surface temperature (option)

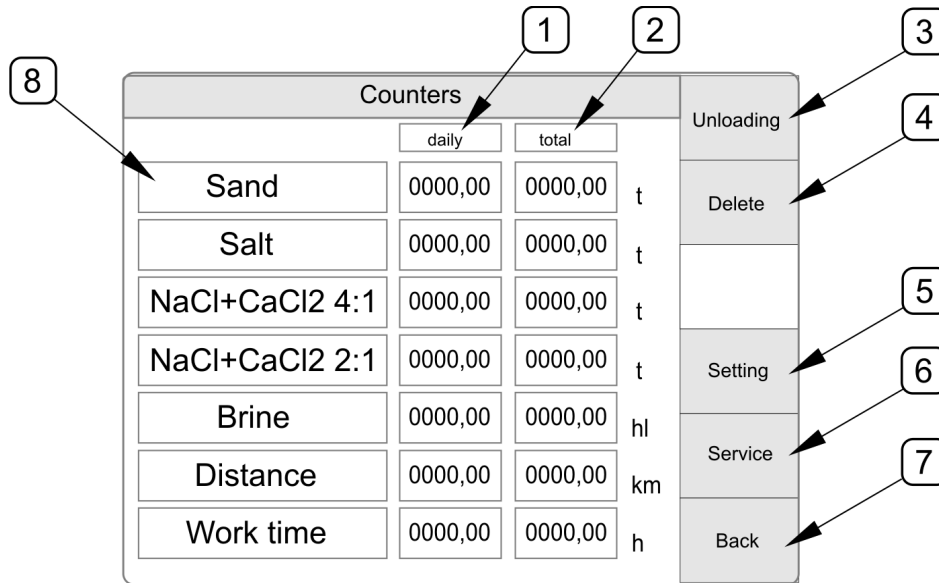

FIG. 4.21 Counter page of control panel display

Description of counter page functions is included in TAB. 4.4

TAB. 4.4 Description of functions on control panel counter page

MARKING FIG. 4.21	FUNCTION NAME	DESCRIPTION
1	"daily"	Daily counter of given material- resettable
2	"total"	Total counter of given material- non-resettable
3	„Unloading”	Start of unloading
4	„Delete”	Resetting (zeroing) of daily counter
5	„Setting”	Moving to page with settings
6	„Service”	Moving to service page (access password must be given)
7	„Back”	Back to previous page
8	„Sand”	Type of material

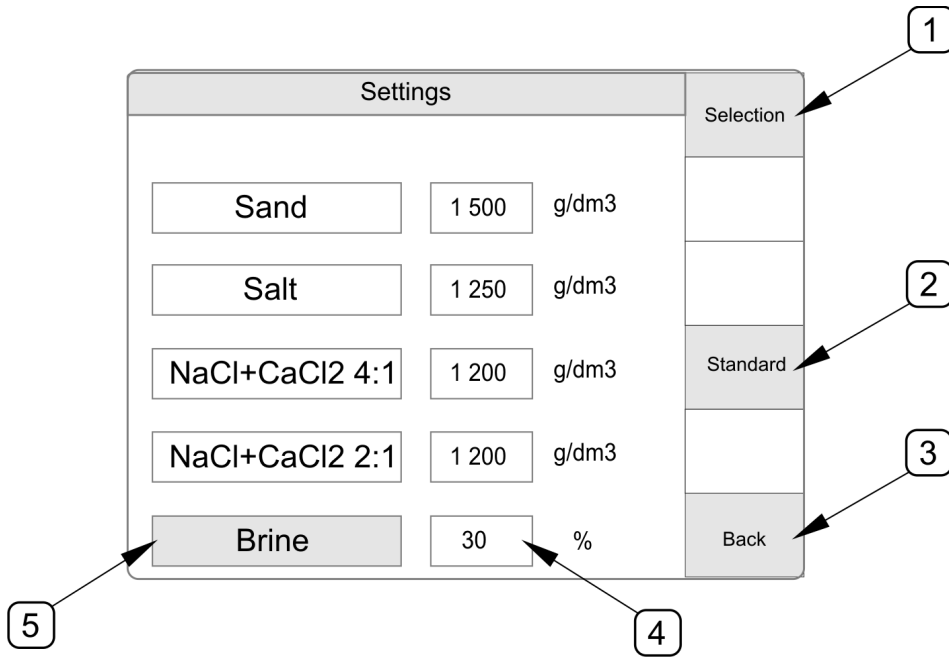

FIG. 4.22 Material setting page of control panel display

Description of setting page functions is included in TAB. 4.5

TAB. 4.5 Description of material setting page functions

MARKING FIG. 4.22	FUNCTION NAME	DESCRIPTION
1	„Selection”	Selecting a type of spreading material
2	„Standard”	Selecting standard values
3	„Back”	Back to previous page
4	"100 g/dm3" "30 %"	Setting of specific gravity of material and percentage content of brine
5	„Brine”	Marked type of material to change

Parametres			Parameter
width adjustment - sand	0	rpm	
width adjustment - salt	0	rpm	
width adj. NaCl+CaCl2 4:1	0	rpm	
width adj. NaCl+CaCl2 2:1	0	rpm	
grammage adjustment - sand	0	%	
grammage adjustment - salt	0	%	
grammage adj. NaCl+CaCl2 4:1	0	%	
grammage adj. NaCl+CaCl2 2:1	0	%	
weight adjustment - brine	0	%	
			Back

FIG. 4.23 Parameter correction page

Description of parameter page functions is included in TAB. 4.6



TIP

A password must be given in order to enter the parameter correction page "Parameters".

TAB. 4.6 Description of parameter correction page functions

MARKING FIG. 4.23	FUNCTION NAME	DESCRIPTION
1	„Parameter”	Selecting a parameter
2	„Back”	Back to previous page
3	"width adjustment - sand"	Selecting a type of correction and type of material
4	"0 rpm" or "0%"	Parameter correction value rpm - correction of rotations per minute % - percentage correction

4.7 MACHINE OPERATION

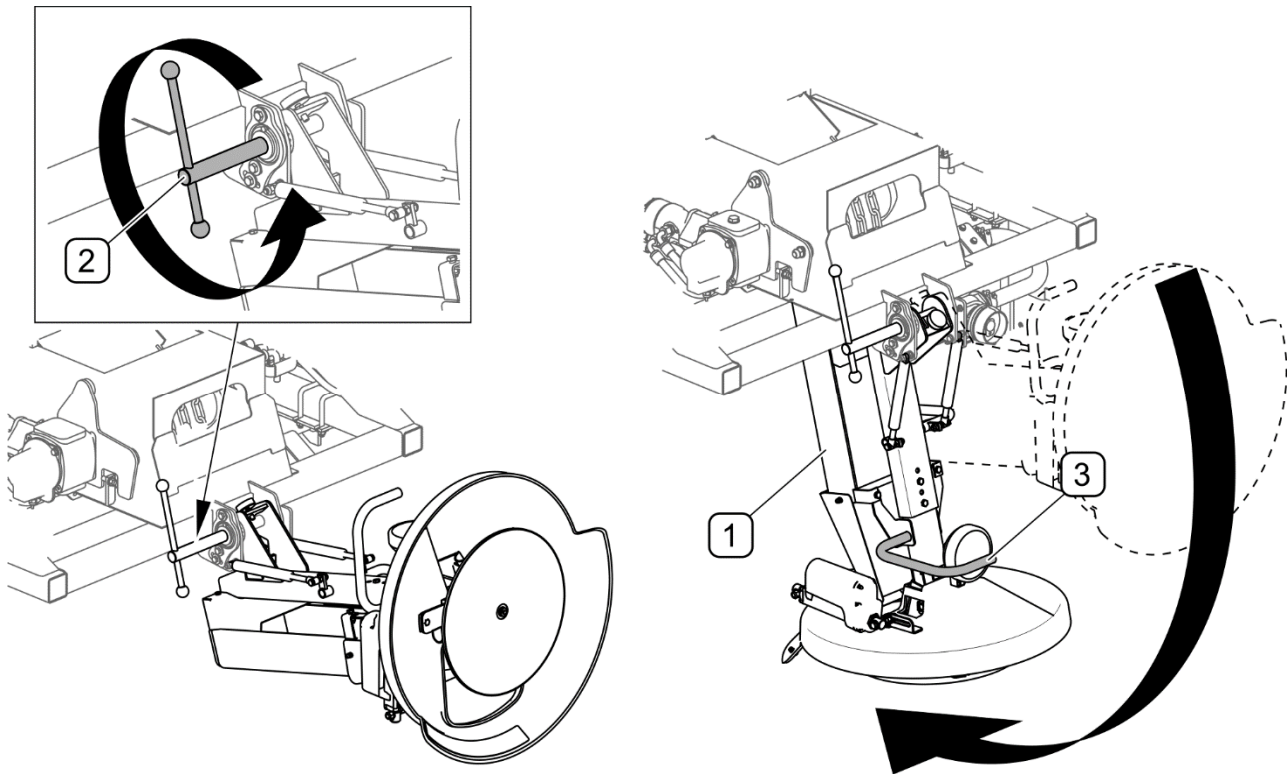

FIG. 4.24 Lowering the spreading mechanism

(1) - spreading mechanism; (2) - clamp bolt; (3) - grip



DANGER

The spreading mechanism may be lowered and raised only if the machine is switched off.

Lower the spreading mechanism (FIG. 4.24) to working position (if it was raised before). In order to do this:

- loosen clamp bolt (2),
- lower the spreading mechanism (1) while holding grip (3),
- tighten clamp bolt (2).

Depending on spreading material, belt conveyor shutter (FIG. 4.25) should be set in one of the three positions:

- Position (A) – salt spreading (conveyor shutter opening: 30 mm).
- Position (B) – sand spreading (conveyor shutter opening: 120 mm).
- Position (C) – tank emptying (conveyor shutter maximally opened)

To change position of shutter (1), turn and pull pin (2), move slide (3) to selected position (A), (B) and lock pin (2) in proper slide opening. To set position (C), pull out slide (3) completely and leave locking pin (2) in pulled out position. Position (C) is used only when unloading material from the tank of parked sand spreader (see.4.9 UNLOADING)

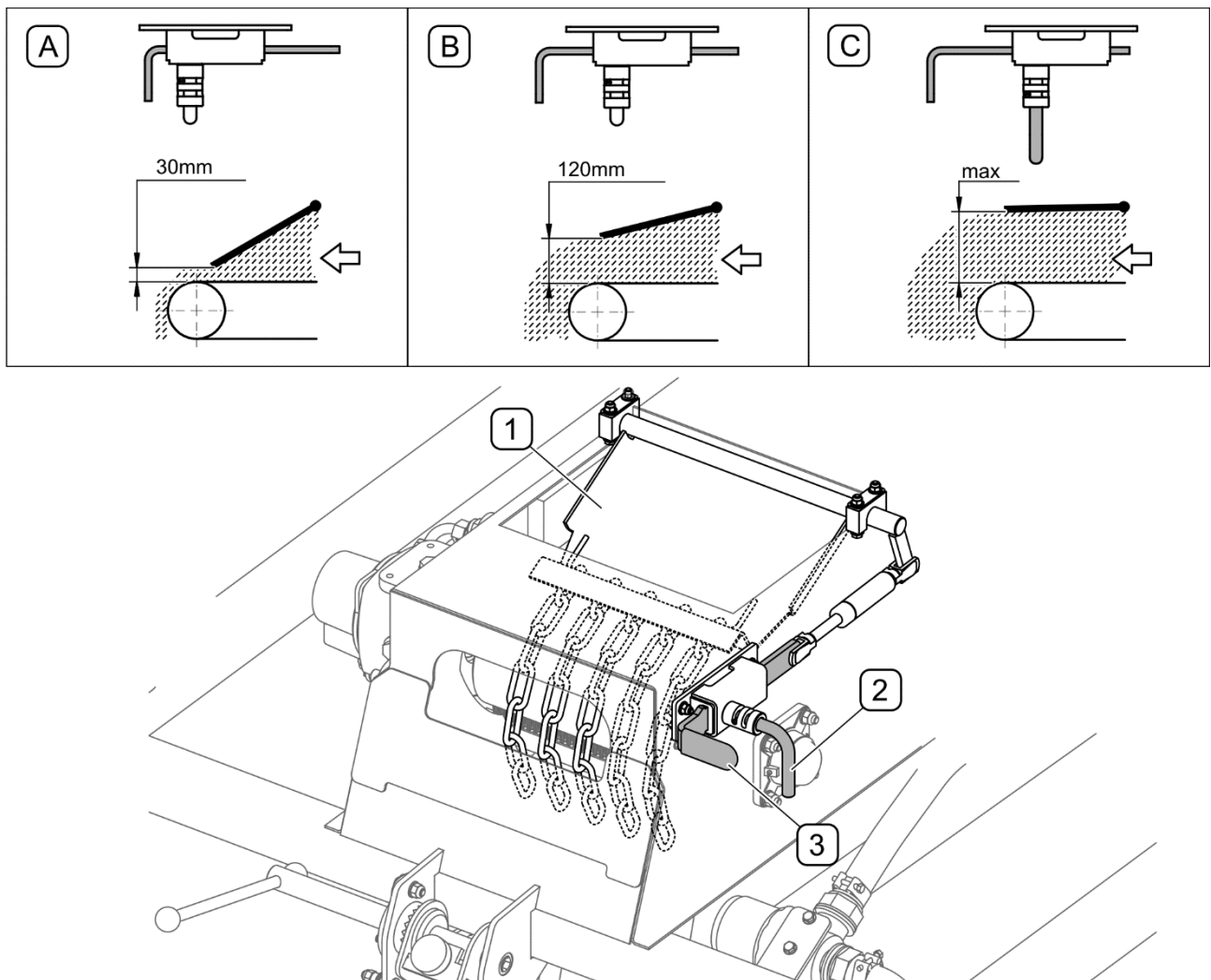

FIG. 4.25 **Setting the belt conveyor shutter**

(A) - salt spreading; (B) - sand spreading; (C) - tank emptying; (1) - shutter; (2) - locking pin; (3) - slide;

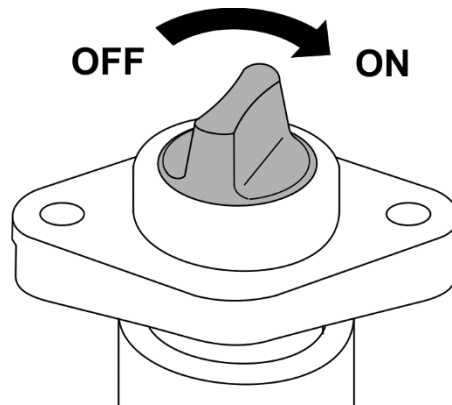

FIG. 4.26 Main switch of control panel

(ON) - switched on; (OFF) - switched off

To switch on power supply, turn main switch (FIG. 4.26) clockwise to (ON) position - switched on. The switch is installed on the control panel power lead.

Mark mode selection field (A) on „START” home page of the control panel (FIG. 4.27) by means of push-button (1) „Selection”. Select "Manual mode" by means of push-button (2) "Change". Move to field (B) by means of push-button (1) „Selection” and select the type of material to be spread. By means of „Change” push-button, select the type of material to be spread that is currently in the tank. By means of push-button (3), turn on warning lamp (5) at the rear of the machine and lamp (6) near the spreading disc. Move to working page "OPERATION" by means of push-button (4)

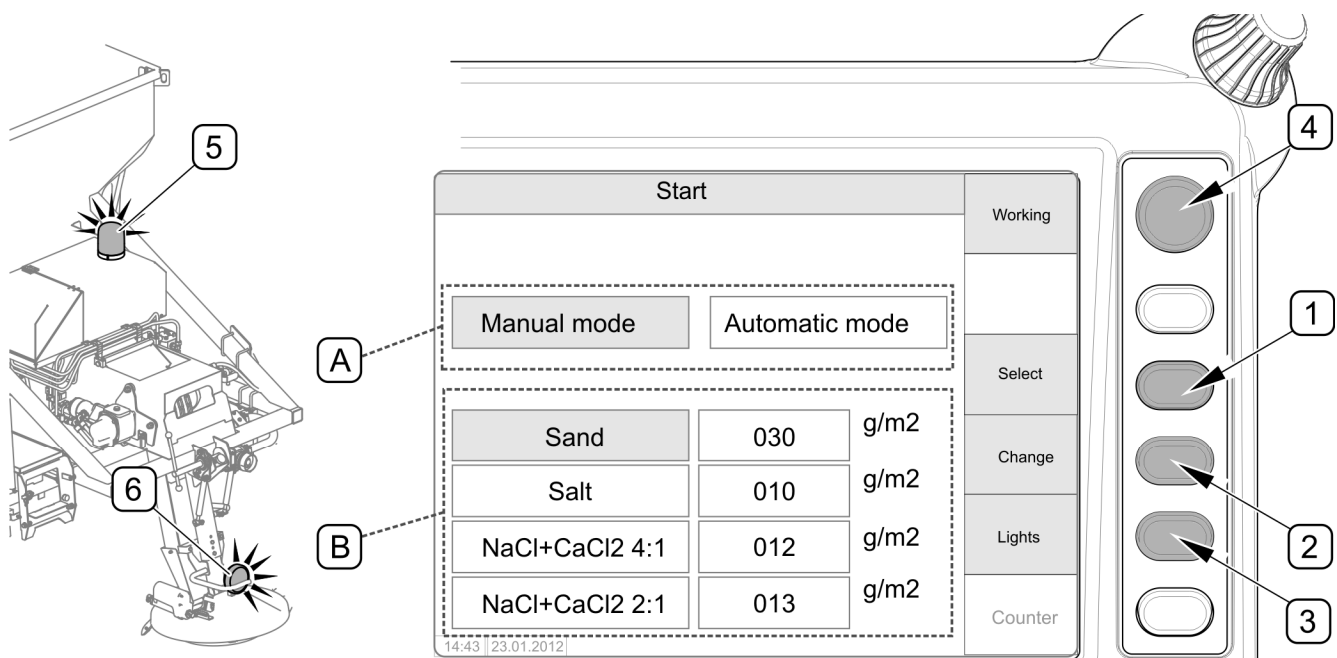

FIG. 4.27 Activating individual functions on control panel home page

(A) - working mode selection field; (B) - material selection field; (1),(2),(3),(4) - function push-buttons; (5) - beacon light; (6) - rear light

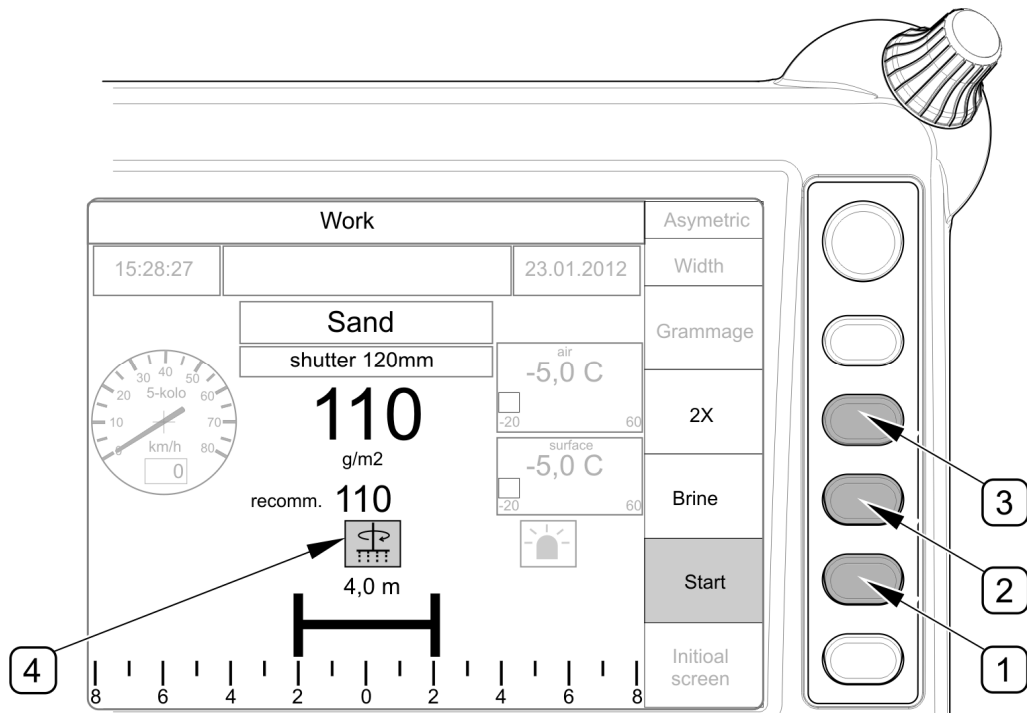

FIG. 4.28 Activation of spreading

(1) - spreading activation push-button; (2) - brine spraying activation push-button; (3) - double dose push-button; (4) - control icon of activated spreading

On control panel working page "Operation" (FIG. 4.28), activate spreading by means of push-button (1); "Start" function will be highlighted. Activation of spreading disc drive and belt conveyor is signalled by control icon (4). Brine spraying is switched on and off by means of push-button (2) "Brine". Push-button (3), marked „2X", is used for momentary doubling of spreading material dose.

When spreading is activated, start driving. Adjust travelling speed to road conditions and spreading material:

- travelling speed during sand spreading: 10 – 40 km/h
- travelling speed during salt spreading: 10 – 70 km/h



DANGER

There must be no bystanders within the sand spreader working zone.

4.7.1 CHANGING WIDTH AND ASYMMETRY OF SPREADING

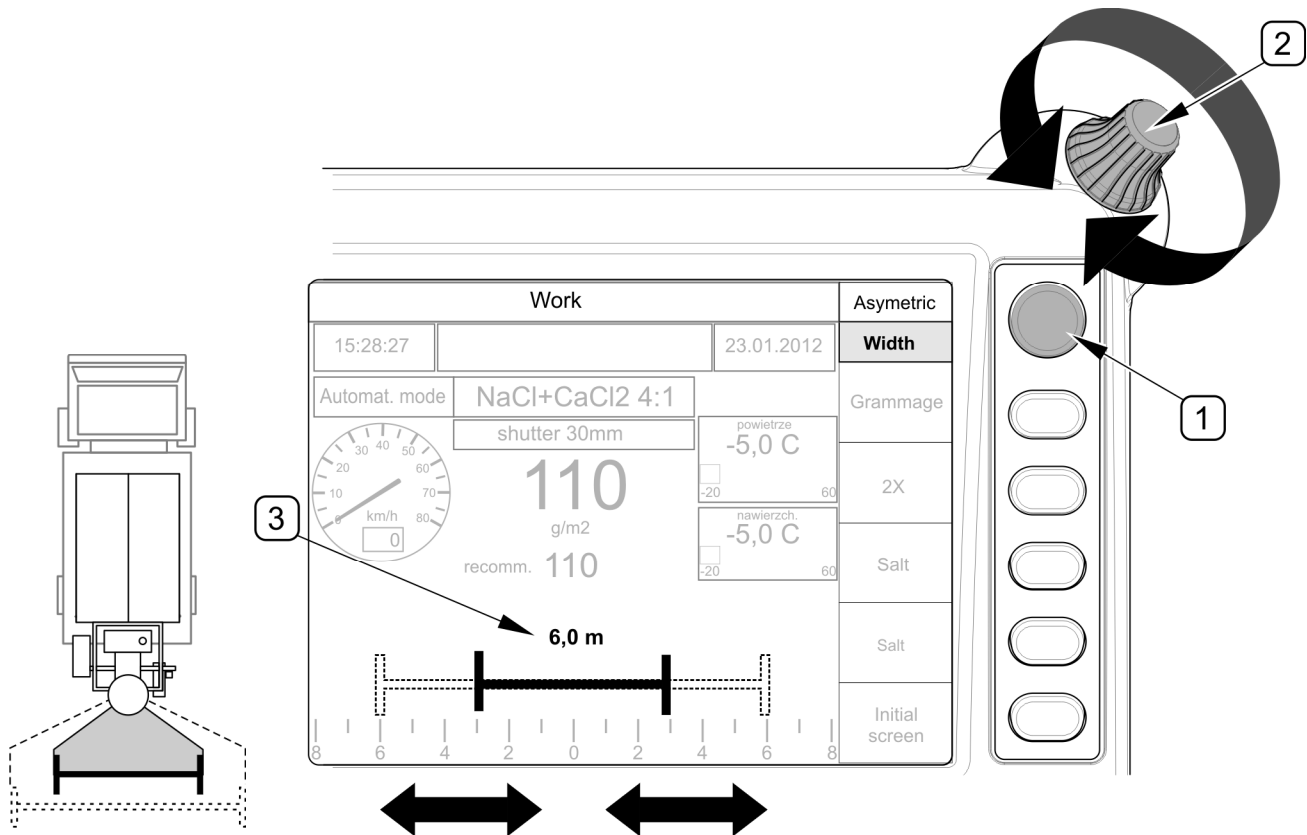

FIG. 4.29 Adjustment of spreading width

(1) - selection push-button "Asymetric-Width"; (2) - parameter value change knob; (3) - current spreading width

Spreading width is changed from the operator cab, on control panel working page ("OPERATION"). To change spreading width:

- highlight "Width" function by means of push-button (1)
- turn knob (2) to set a required width (3) from 2 m ÷ 12 m

To change asymmetry of spreading, highlight "Asymmetry" field on working page "Operation" by means of push-button (1). Turn knob (2) to move current spreading width to the right or to the left (FIG. 4.30).

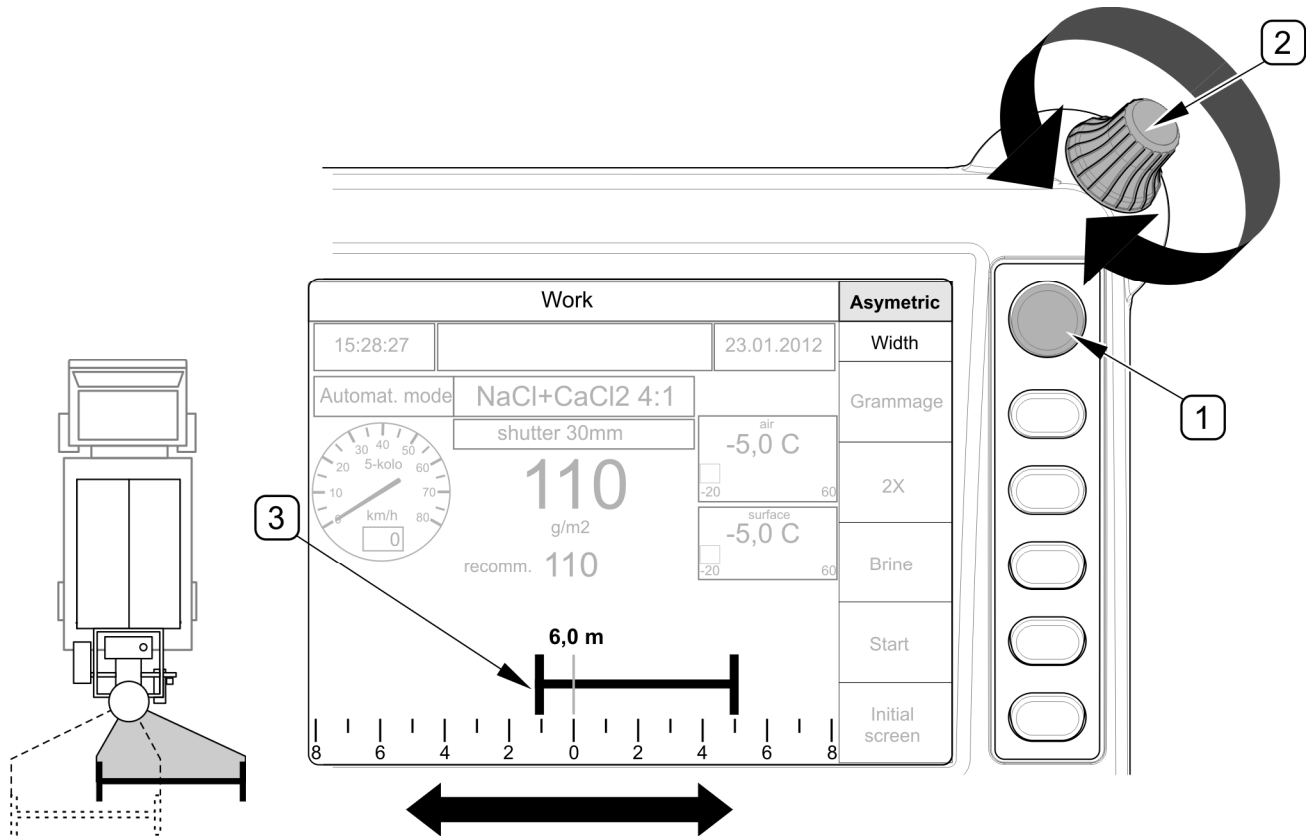

FIG. 4.30 Changing asymmetry of spreading

(1) - selection push-button "Asymetric-Width"; (2) - parameter change knob;
 (3) - graphic image of spreading asymmetry

For example, in the figure above, for spreading width of 6 m, spreading asymmetry is shifted to the right.

4.7.2 OPERATION IN AUTOMATIC MODE (OPTION)

Optionally, the sand spreader can operate in automatic working mode. In automatic working mode, the electronic system selects a proper dose of material on the basis of road surface temperature measurement and selected, defined working mode. Three working modes are defined in the automatic working mode:

- prevention of formation of black ice, glazed frost, hoarfrost,
- prevention of snow freezing to road surface,
- elimination of black ice, hoarfrost, thin layers of compacted or icy snow, remains of fresh snow

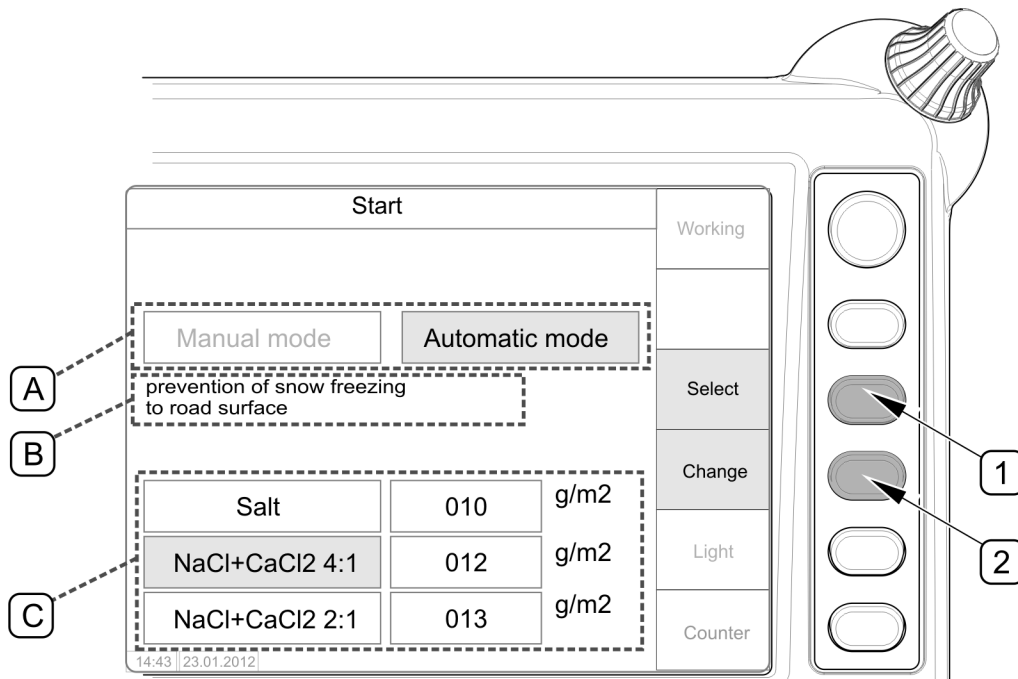

FIG. 4.31 Selection of automatic mode (option)

(1) - push-button for selecting field A,B or C for editing; (2) - push-button for changing a marked field;(A) - field of working mode type (automatic/manual); (B) - field for selecting automatic mode type T1, T2, T3; (B) - field for selecting a spreading material

To select automatic mode (option):

- mark working mode type selection field (A) on „Start” home page of the control panel (FIG. 4.31) by means of push-button (1),
- select "Automatic mode" by means of push-button (2) "Change"
- select one of the three defined modes T1,T2,T3 by means of push-button (1) "Selection",
- by means of push-button (1), mark field (C) and then, by means of push-button (2) „Change”, select (C) type of material to be spread that is currently in the tank (automatic mode can not be selected for „Sand”)

On control panel working page ("Operation") (FIG. 4.32), the operator can correct the dose for a defined automatic mode after selecting "Spreading density" function by means of push-button (1). Correction is made by means of knob (5). Recommended density (3) for a defined mode T1, T2 or T3 is displayed below spreading density set by the operator (2) (FIG. 4.32)

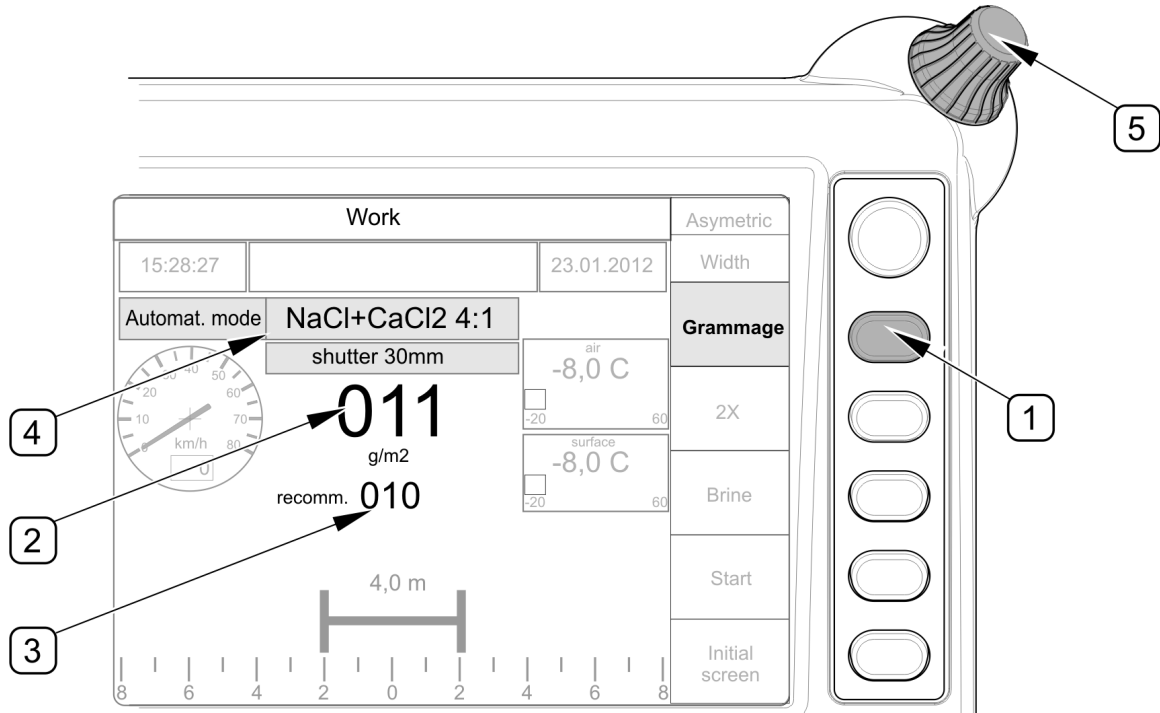

FIG. 4.32 Correction in automatic mode (option)

(1) - dose correction push-button; (2) - values set by the operator; (3) - recommended value; (4) - previously selected material and working mode; (5) - parameter change knob

TAB. 4.7 Examples of specific weights of spreading materials

TYPE OF MATERIAL	MATERIAL NAME	Specific weight [kg/dm ³]	Weight per m ³ [kg]
Solid material	Medium sand	1.60	1,600
	Coarse sand	1.60	1,600
	Fine salt (NaCl)	1.20	1,200
	Coarse salt (NaCl)	1.32	1,320
TYPE OF MATERIAL	MATERIAL NAME	Specific weight [kg/dm ³]	Weight per 1 000 litres [kg]
Liquid	Calcium solution (CaCl ₂)	1.16	1,160
	Saline solution (NaCl)	1.20	1,200

TIP

When road surface temperature change is detected, while working in auto mode electronic system will change preset spreading density while maintaining the value added or subtracted previously by the operator.

If spreading density is not corrected by the operator in automatic mode, the preset value and recommended value will be equal.

4.8 DRIVING ON PUBLIC ROADS

When driving on public or private roads, respect the road traffic regulations, exercise caution and prudence. Make sure that the machine is correctly attached to the carrying vehicle. During operation, ensure that there is suitable visibility, turn on the orange beacon light at the rear of the machine. Special attention should be paid to the bystanders likely to be near the working machine.

DANGER

During spreading, adjust travelling speed to the prevailing road conditions and do not exceed the following values:

- travelling speed during sand spreading: 10 – 40 km/h
- travelling speed during salt spreading: 10 – 70 km/h

Avoid ruts, depressions, ditches or driving on roadside slopes. Driving across such obstacles could cause the carrying vehicle and the machine to suddenly tilt. Driving near ditches or canals is dangerous as there is a risk of the slope collapsing. Speed must be sufficiently reduced before making a turn or driving on an uneven road or a slope. For the period of sand spreader operation, protect the lifting system of the carrying vehicle's load platform (if any) against automatic or accidental activation. If the machine will not be used during travel, raising of hydraulic system drive wheel is recommended.

4.9 UNLOADING

4.9.1 EMPTYING THE TANK



DANGER

Before leaving the cab, turn off the vehicle's engine, engage the parking brake and secure the vehicle's cab against access of third persons.

Exercise caution while unloading.

Before dismounting the sand spreader from the carrying vehicle's load platform, before adjusting works, repairs and in case of spreading material change, the machine's tank should be completely emptied. In order to do this:

- raise the spreading unit and lock it in the upper position (FIG. 4.33)
- set belt conveyor shutter to maximally open position (FIG. 4.34),
- On control panel "Counters" page, select "Unloading" function,
- run an external hydraulic circuit of the carrying vehicle

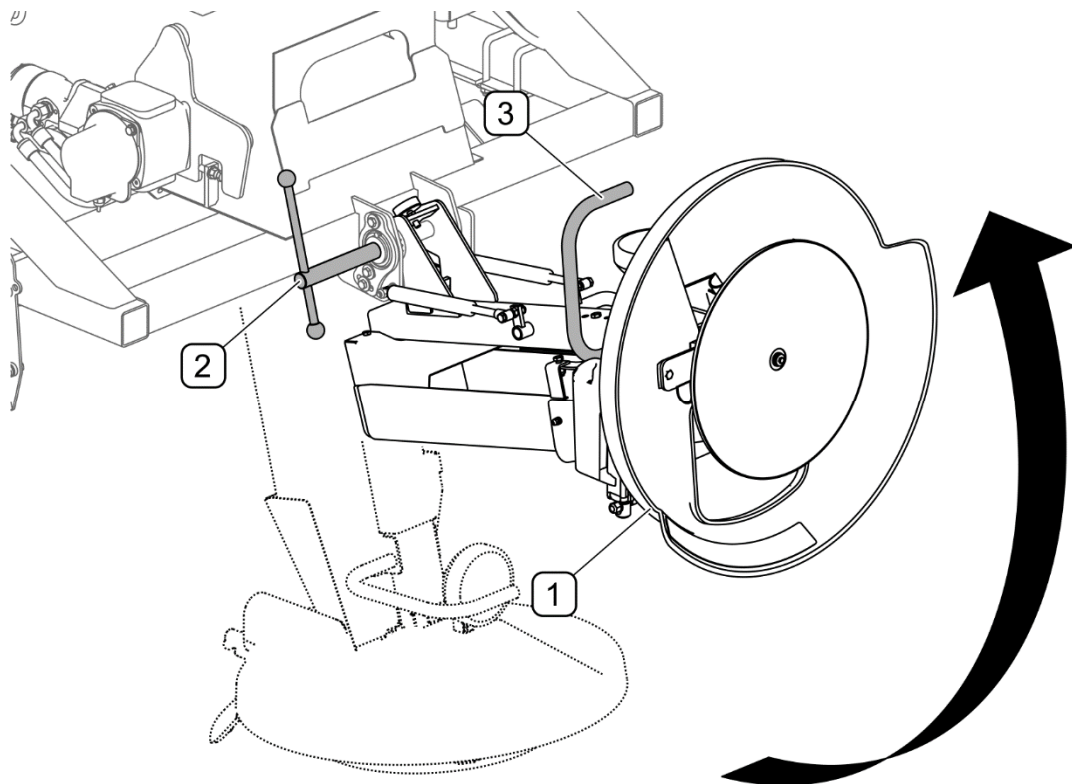

FIG. 4.33 Raising the spreading mechanism

(1) - spreading mechanism; (2) - clamp bolt; (3) - grip

To raise the spreading mechanism for unloading (FIG. 4.33) do the following:

- loosen clamp bolt (2),
- raise spreading mechanism (1) while holding grip (3),
- tighten clamp bolt (2).

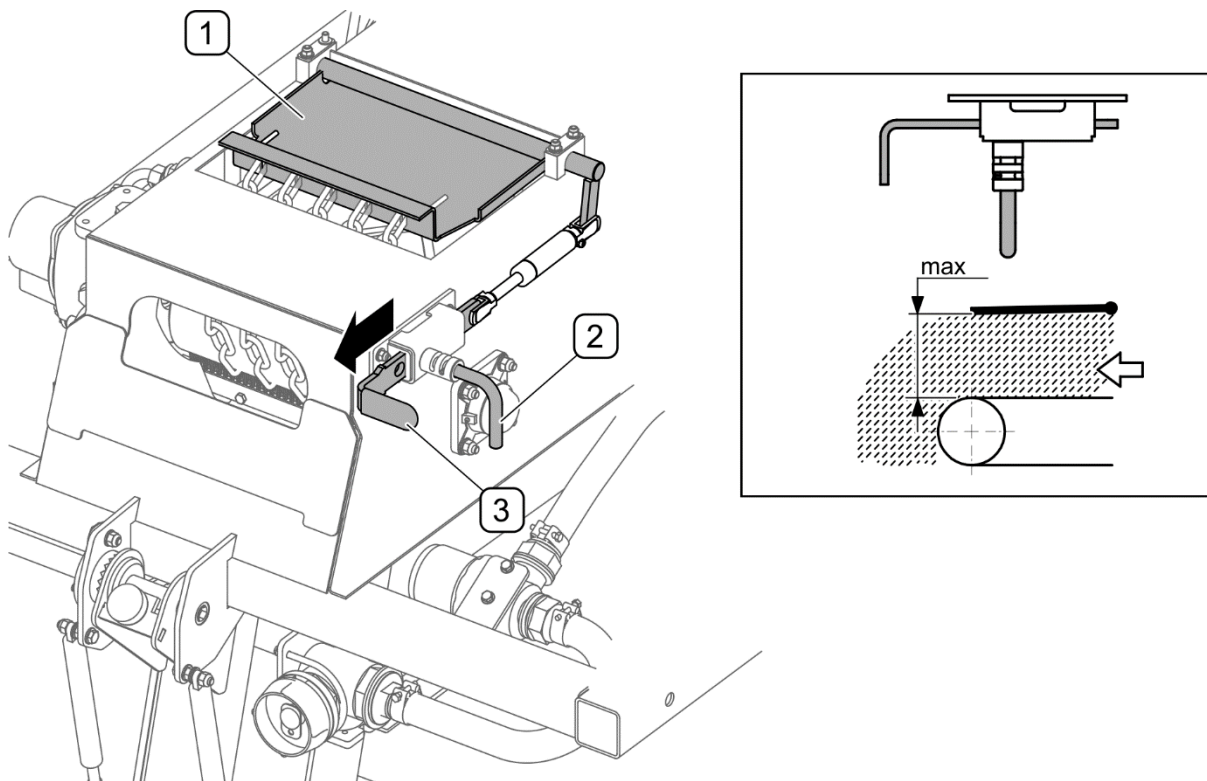

FIG. 4.34 Setting the belt conveyor shutter for unloading

(1) - shutter; (2) - locking pin; (3) - slide;

After complete emptying the tank, turn off external hydraulic system of the carrying vehicle and deactivate "Unloading" function on control panel. Lower the spreading system to working position and set belt conveyor shutter to proper position.

To set the shutter (1) for unloading, (FIG. 4.34) turn and pull pin (2) and raise the shutter by pulling the slide (3). The shutter is set to maximally open position (FIG. 4.34) only when material is being unloaded from the tank.

4.9.2 EMPTYING BRINE TANKS

Before dismantling the sand spreader from the carrying vehicle's load platform and before repairs of spray system, empty the brine tanks.

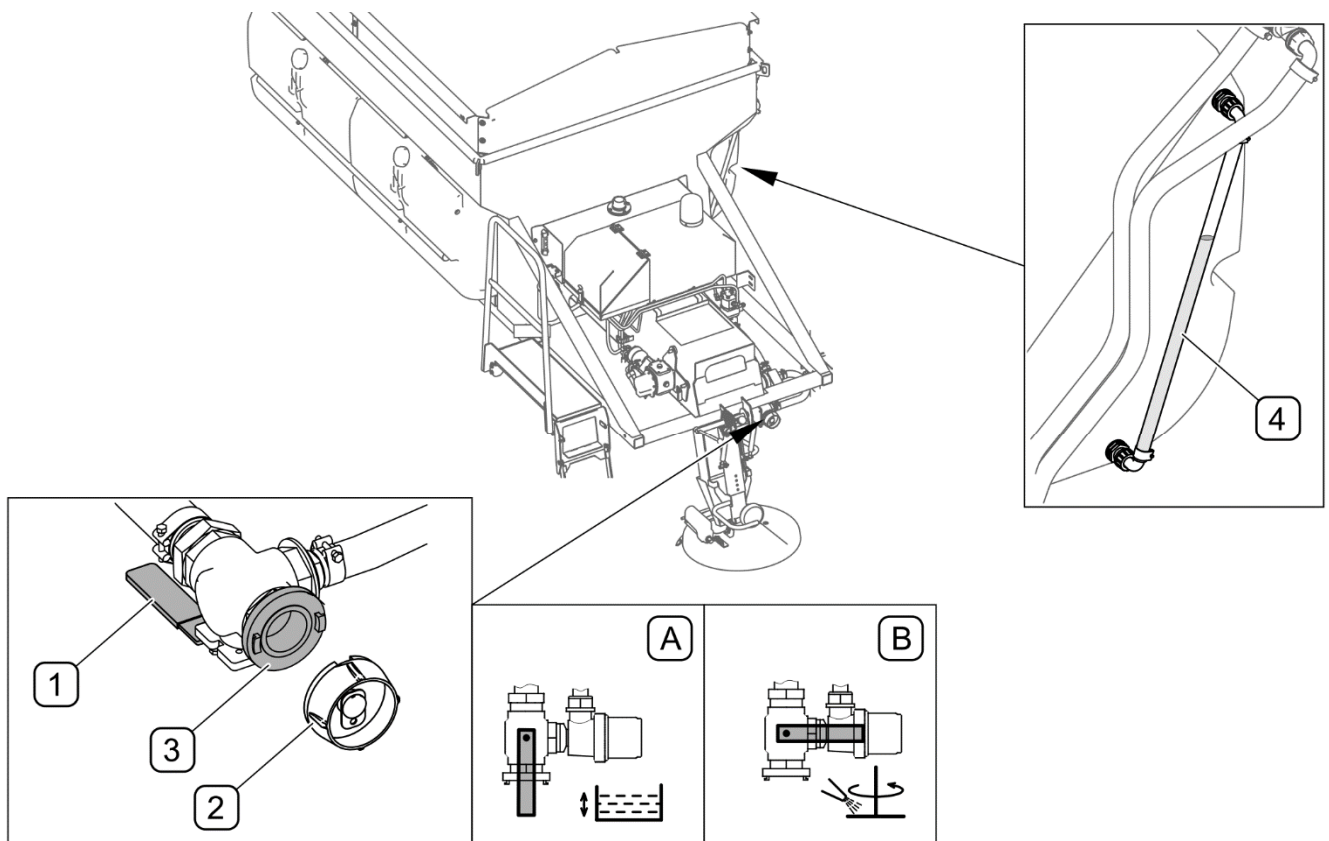
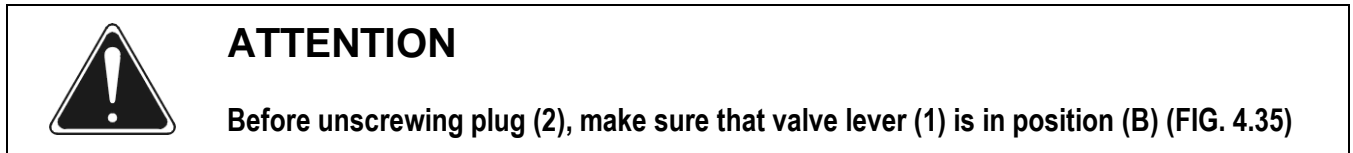

FIG. 4.35 Emptying brine tanks

(1) - valve lever; (2) - valve plug; (3) - STORZ 52C valve connection; (4) - brine level indicator; (A) - valve in „filling/emptying” position; (B) - valve in "brine spraying" position;

To empty the brine tanks proceed as follows:

- prepare a container for brine,
- set valve lever (1) in position (B),
- unscrew plug (2) and connect proper drain hose to connection (3),
- set valve lever (1) to position (A) and start emptying the tanks,
- brine level is checked on brine level indicator (4) located on the tank,

- after emptying the tanks, set lever (1) to position (B),
- disconnect drain hose from connection (3) and tighten drain plug (2).

4.10 DISMOUNTING THE MACHINE FROM THE CARRYING VEHICLE'S LOAD PLATFORM

DANGER



Before dismounting the machine from the carrying vehicle's load platform, turn off the vehicle's engine, engage the parking brake and secure the vehicle's cab against access of third persons.

Exercise particular caution when dismounting the machine.

DANGER



Reduce pressure prior to disconnecting the machine from hydraulic system of the carrying vehicle.

ATTENTION



Before dismounting the machine from the carrying vehicle's load platform, the spreading material tank and brine tanks should be completely emptied.

Machine removed from the carrying vehicle must be placed on parking stands, on level, sufficiently hard surface in such a manner as to ensure that it is possible to connect it again.

To dismount the machine from the carrying vehicle's load platform proceed as follows:

- Place the carrying vehicle's load platform in the area where the machine is to be stored.
- Disconnect control panel, electrical leads and hydraulic quick couplers.
- Remove straps fastening the machine to the carrying vehicle's load platform.
- Install front (1) and rear (2) parking stands (FIG. 4.36) and lock them using (2) linchpins (3) and cotter pins (4).
- Raise the parking stands uniformly by means of height adjustment mechanism.

- When the sand spreader is completely raised above the carrying vehicle's load platform, drive the carrying vehicle away from the machine.

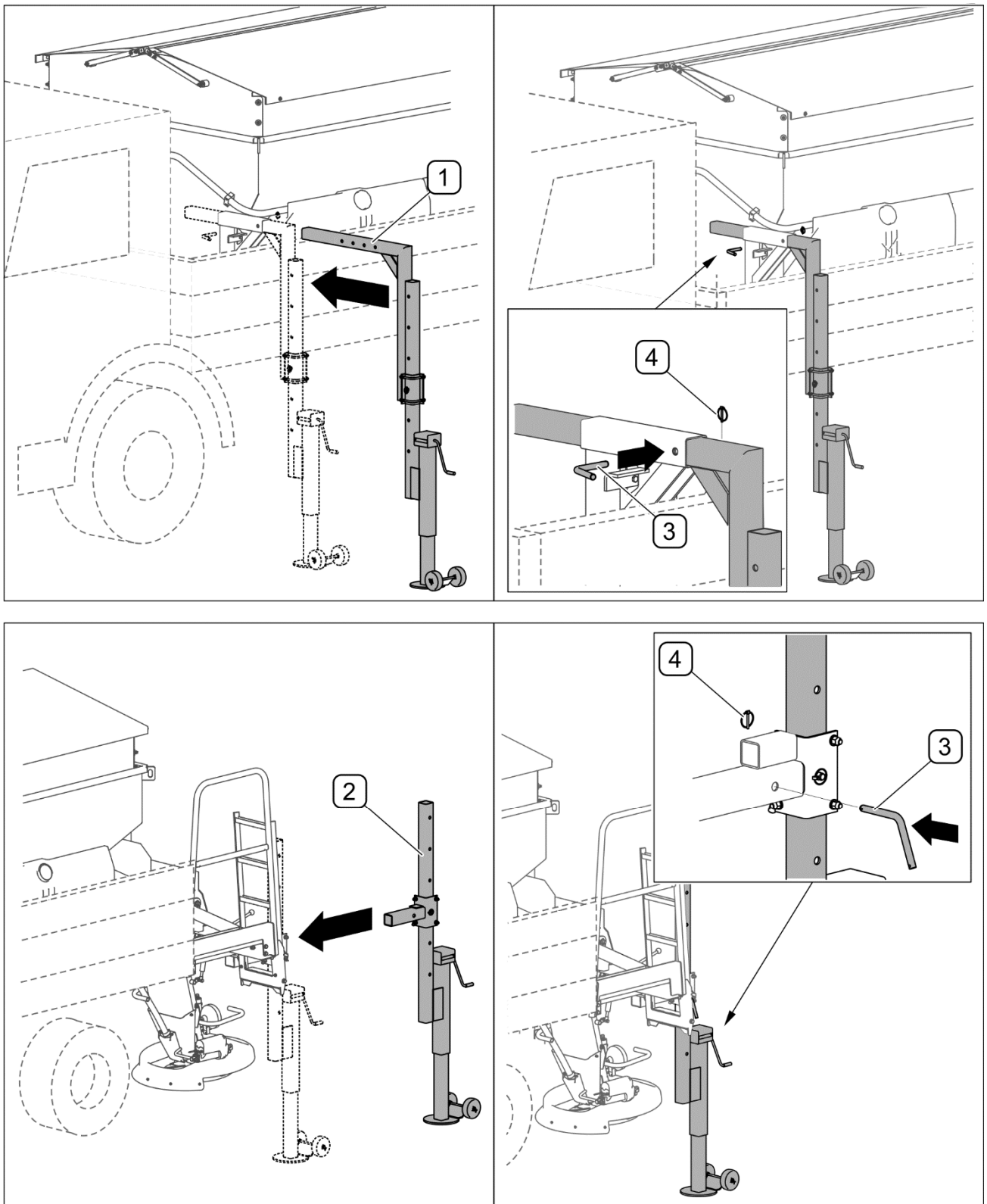

FIG. 4.36 Installing the parking stands

(1) - front parking stand; (2) - rear parking stand; (3) - pin; (4) - linchpin



ATTENTION

Hydraulic quick couplers disconnected from the carrying vehicle should be protected against contamination.

SECTION

5

MAINTENANCE

5.1 HYDRAULIC SYSTEM OPERATION

The duties of the operator connected with the hydraulic system include:

- visual inspection of tightness of hydraulic pumps, motors and connections,
- checking technical condition of conduits,
- visual inspection of hydraulic conduits,
- periodical replacement and cleaning of filter cartridges (option)



DANGER

Do not repair hydraulic system on your own. All hydraulic system repairs must be performed only by suitably qualified personnel.



ATTENTION!

Before you begin, visually inspect the hydraulic system components.



DANGER

During work on hydraulic systems use the appropriate personal protection equipment i.e. protective clothing, footwear, gloves and eye protection. Avoid contact of skin with oil.

In the event of contact of oil with skin wash the place of contact with water and soap. Do NOT apply organic solvents (petrol, kerosene). Contaminated clothing should be changed to prevent access of oil to skin. In the event of contact of oil with eye, rinse with large quantity of water and in the event of the occurrence of irritation consult a doctor.



DANGER

Oil fires should be quenched with carbon dioxide (CO₂), foam or extinguisher steam. Do NOT use water for fire extinguishing!

Spilt oil should be immediately collected and placed in marked tight container. Used oil should be taken to the appropriate facility dealing with the re-use of this type of waste.

The hydraulic system should be completely tight sealed. Minimum leaks are permissible with symptoms of "sweating", however in the event of noticing leaks in the form of "droplets" stop using the machine until faults are remedied.

ATTENTION!



The machine with a leaking hydraulic system must NOT be used.

The hydraulic system is under high pressure when operating.

Regularly check the technical condition of the connections and the hydraulic conduits.

The hydraulic system is filled with L-HL-32 hydraulic oil.



The condition of hydraulic system should be inspected regularly while using the machine.

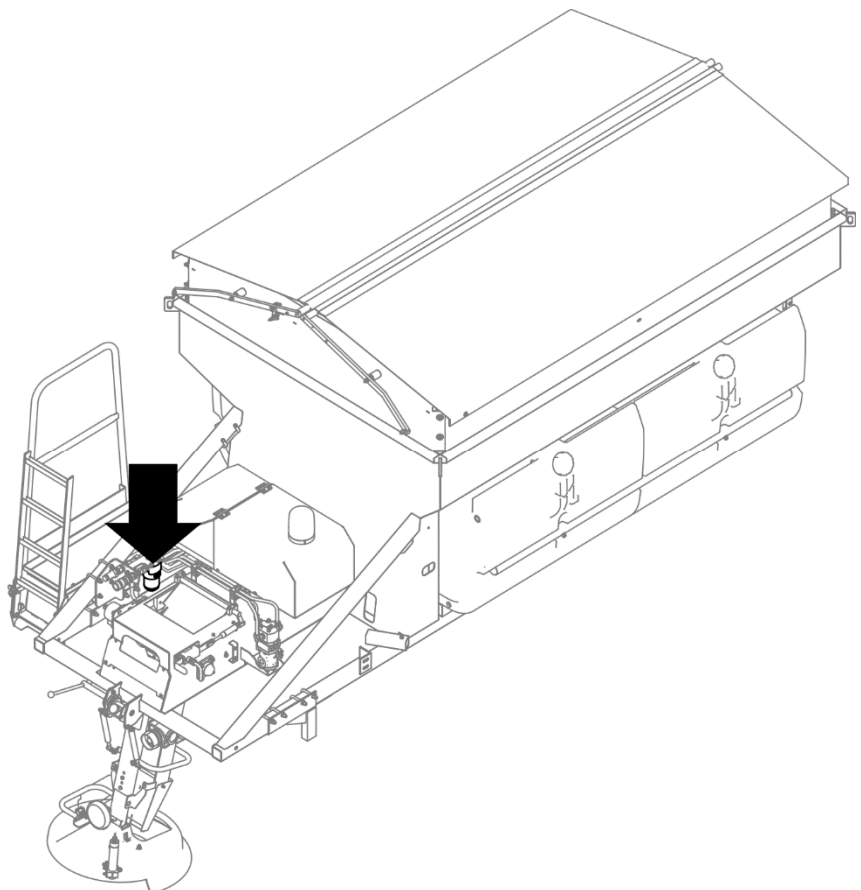
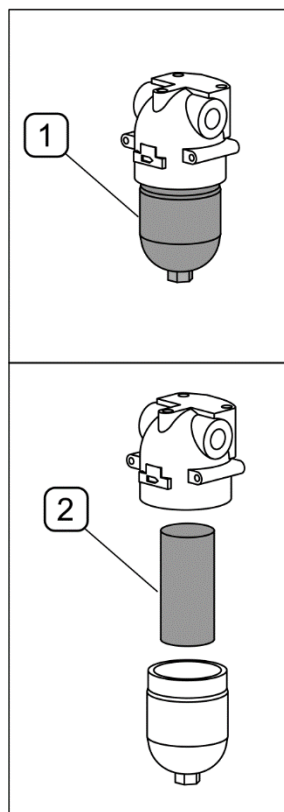

FIG. 5.1 Replacement of oil filter (option)

(1) - oil filter housing; (2) - replaceable filter cartridge

The sand spreader can be also equipped with a pressure oil filter (FIG. 5.1) installed in the hydraulic supply line. Oil filter cartridge (1) should be periodically replaced. Before installing a

new filter, oil the gasket surface. The hydraulic system is vented automatically during machine operation.

**TIP**

Replaceable filter cartridge is installed in the hydraulic system (option) part number CCH306FS1



Cartridge of pressure oil filter (option) (FIG. 5.1) should be replaced every 500 engine working hours or once a year.



Hydraulic conduits must be changed every 4 years regardless of their technical condition.

5.2 ELECTRICAL SYSTEM MAINTENANCE

**DANGER**

Do not independently repair electrical system, except items described in chapter ELECTRICAL SYSTEM MAINTENANCE. All electrical system repairs must be performed only by suitably qualified personnel.

Electrical system maintenance is conducted during the periodical checking the operation of control system and lighting system.

**ATTENTION!**

Before beginning work on electrical system, disconnect the machine from power source.

In case of bulb burnout in beacon light or fog light, replace the bulbs. List of bulbs is shown in TAB. 5.1

TAB. 5.1 LIST OF LIGHTING COMPONENTS

LAMP TYPE	BULB TYPE	NUMBER OF BULBS
Beacon light 2RL-007 550-021	H1, 24V	1
Red fog light M56 56/03/01	BA15S (P21W), 24V	1

In case of electrical system failure, check fuses located under cover (1) at the rear of the sand spreader (FIG. 5.2). Open cover (1) by removing rubber protection (2) from catch (3). Fuses and relays are located in a holder under small cover (4). Remove a blown fuse from the holder and replace it with a new one. List of fuses is shown in TAB. 5.2

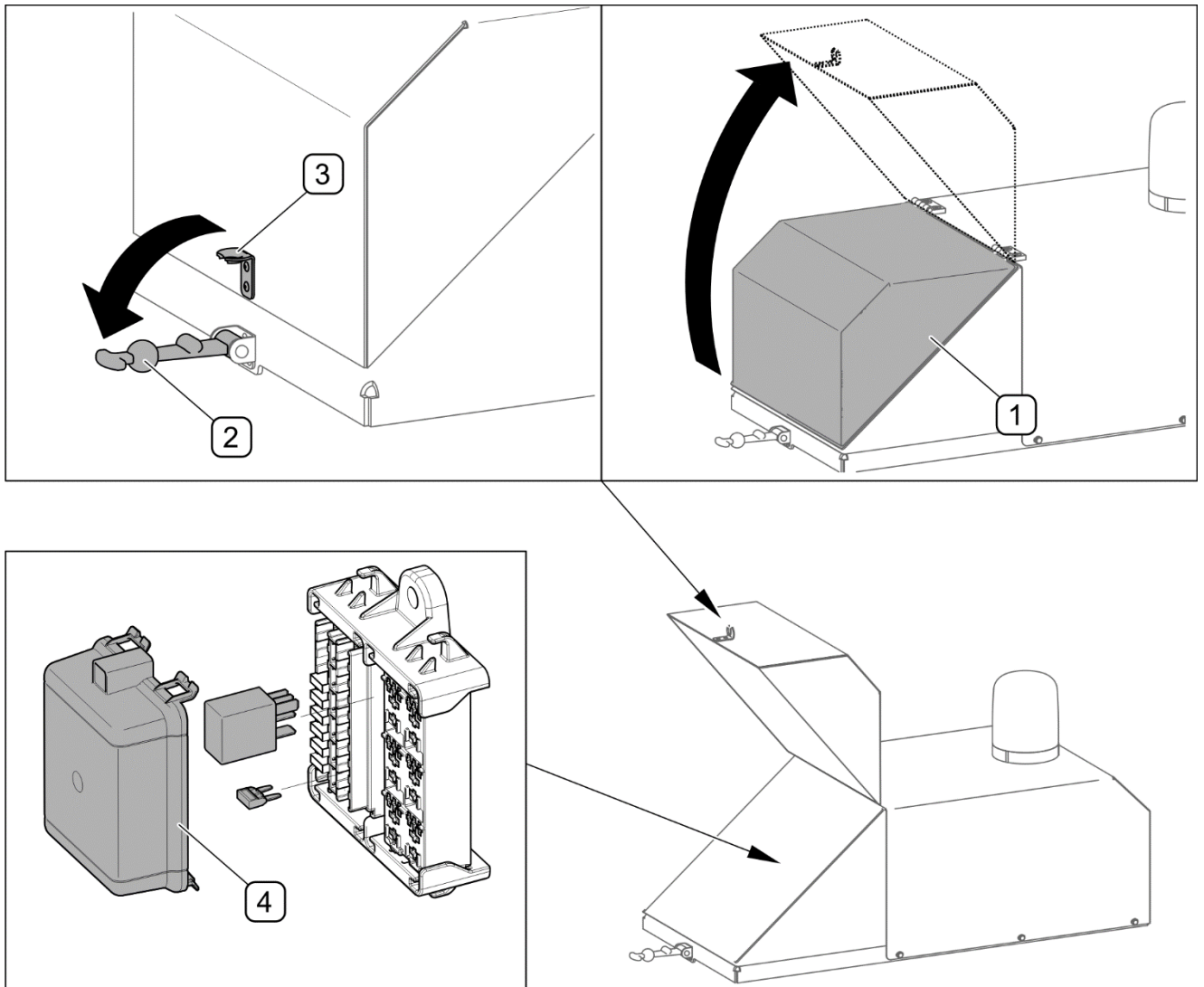

FIG. 5.2 Location of fuse box

(1) - cover; (2) - protection; (3) - catch; (4) - fuse holder cover



TIP

In the fuse box, there are four relays (9), (10), (11) (FIG. 5.3) marked with 10/20A 24V symbol, with part number of K2-1103-0011, and MINIVAL fuses (see TAB. 5.2)

TAB. 5.2 FUSES

MARKING (FIG. 5.3)	PROTECTED CIRCUIT	SAFETY DEVICE
1	Sensors of main controller RC2-2	2A
2	Main controller RC2-2	3A
3	Extension module RCE12/4	20A
4	Extension module sensors RCE12/4	2A
5	Main controller RC2-2	3A
6	Extension module RCE12/4	3A
7	Control panel	5A
8	Spare fuses	2A, 3A, 5A, 20A

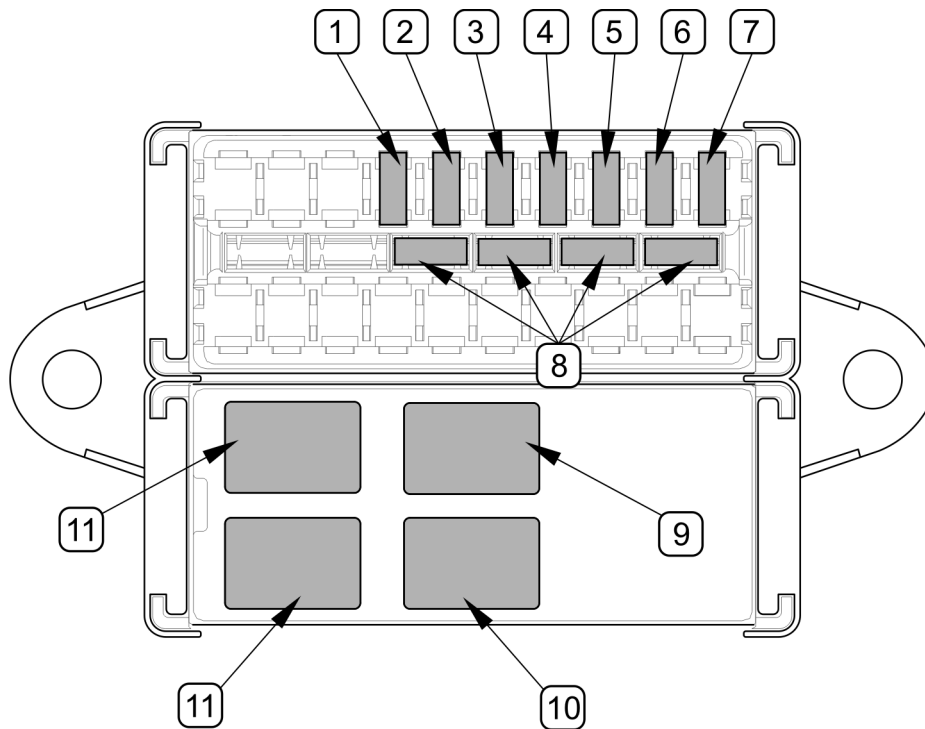

FIG. 5.3 Fuses and relays

(1)...(8) - fuses; (9) - relay of the light near the spreading disc, (10) - beacon light relay, (11) - relays of electrical spreading direction adjusting cylinder

5.3 MAINTENANCE OF BELT CONVEYOR

5.3.1 CHANGING OIL IN THE CONVEYOR DRIVE TRANSMISSION



DANGER

When checking oil level and changing oil, use the appropriate personal protection equipment i.e. protective clothing, footwear, gloves eye protection. Avoid contact of skin with oil.

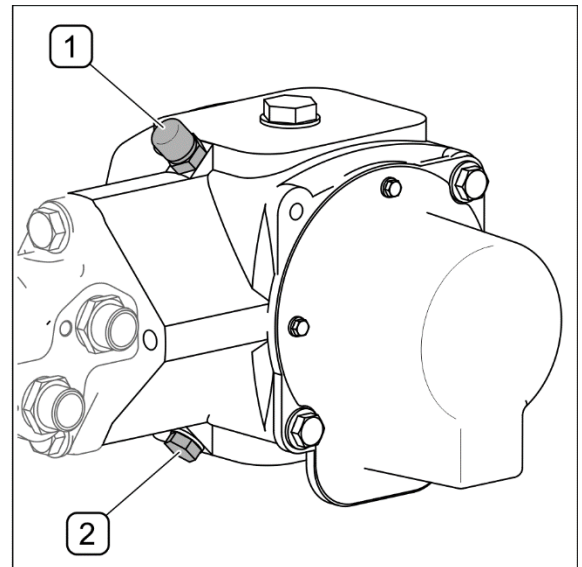
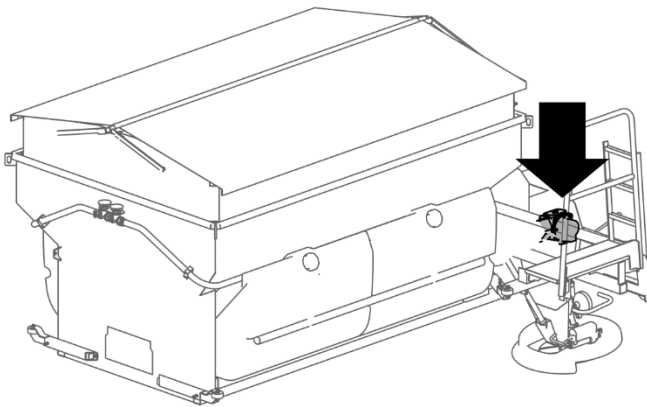

FIG. 5.4 Changing oil in the belt conveyor drive transmission

(1) - oil filler plug with air vent; (2) - drain plug



It is recommended to check oil in the belt conveyor drive transmission before commencing the working season but no less frequently than once a year. Possible oil change is carried out during transmission repair.

Maintenance of belt conveyor drive transmission involves periodical checking of oil level and changing oil. Before changing oil in the belt conveyor drive transmission:

- unscrew filler plug (1) (FIG. 5.4)
- unscrew drain plug (2) and drain oil to previously prepared basin,
- tighten drain plug (2) and pour new oil through filler plug opening (1)
- check that air vent in filler plug (1) is not blocked, if necessary clean the air vent
- tighten drain plug (2).

**TIP**

To lubricate the belt conveyor drive transmission use gear oil of SAE 90 EP class, in the amount of 0,6 L (litres).

Used oil should be taken to the appropriate facility dealing with the re-use of this type of waste.

If a leak is noticed, carefully inspect seals and check oil level. Transmission operation with insufficient oil may cause permanent damage of the mechanism.

Repair of transmission during warranty period may only be performed at authorised mechanical workshops.

5.3.2 ADJUSTMENT OF CONVEYOR BELT

Moving conveyor belt should be positioned in the middle of the conveyor roller. Make adjustments if the conveyor belt is shifted sideways to the edge of the conveyor roller.

**DANGER**

Conveyor belt adjustment is performed when the sand spreader is parked and the conveyor drive is switched on. Be especially careful when making the adjustment.

Before starting conveyor belt adjustment (FIG. 5.5), unscrew bolts (4) and (5) and remove cover (3). Start the carrying vehicle's external hydraulic circuit that supplies the machine. Activate "Unloading" function in "Counters" menu on the control panel. A detailed description can be found in section *4.9 UNLOADING*.

Conveyor belt is adjusted during conveyor operation by means of tensioning bolts (1) and (2) located on the front wall of the tank (FIG. 5.5). Depending on shifting of conveyor belt (FIG. 5.5), choose proper rotation direction of tensioning bolts (1) and (2). During the adjustment, make one turn of each bolt and wait for some time to see the effect of the adjustment. Repeat the activity until moving conveyor belt is positioned in the middle of the conveyor roller.

**TIP**

In new sand spreaders and when replacing the conveyor belt, adjust the conveyor belt tension using the torque of 15 Nm. During normal operation of the machine, adjust the conveyor belt tension using the torque of 7 Nm.

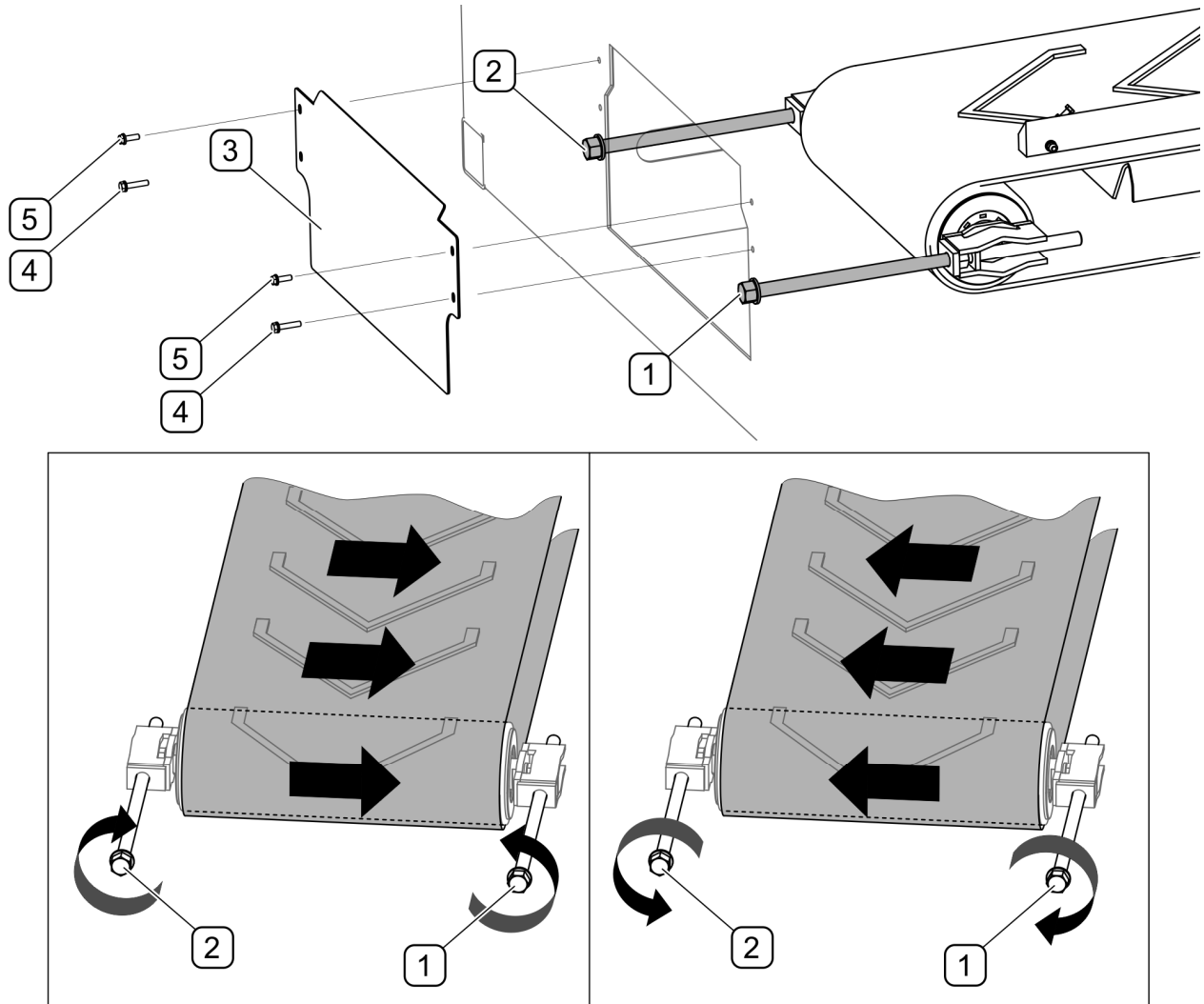

FIG. 5.5 Adjustment of tightening roller

(1), (2) - adjusting screws; (3) - cover; (4) - M6x30 bolt; (5) - M6x20 bolt



Check daily whether moving conveyor belt is positioned in the middle of the tightening roller and drive roller of the conveyor. Make adjustments if the conveyor belt is shifted sideways to the edge of the conveyor roller.

Tension of conveyor belt should be checked at least once a month during the working season.

Conveyor belt can be tightened when the conveyor drive is switched off. Conveyor belt is tightened by means of bolts (1) and (2) located on the front wall of the tank (FIG. 5.5). Turn both bolts (1) and (2) clockwise using force of about 15 Nm. To avoid shifting the belt sideways to the edge of the roller, turn both bolts by the same number of rotations.

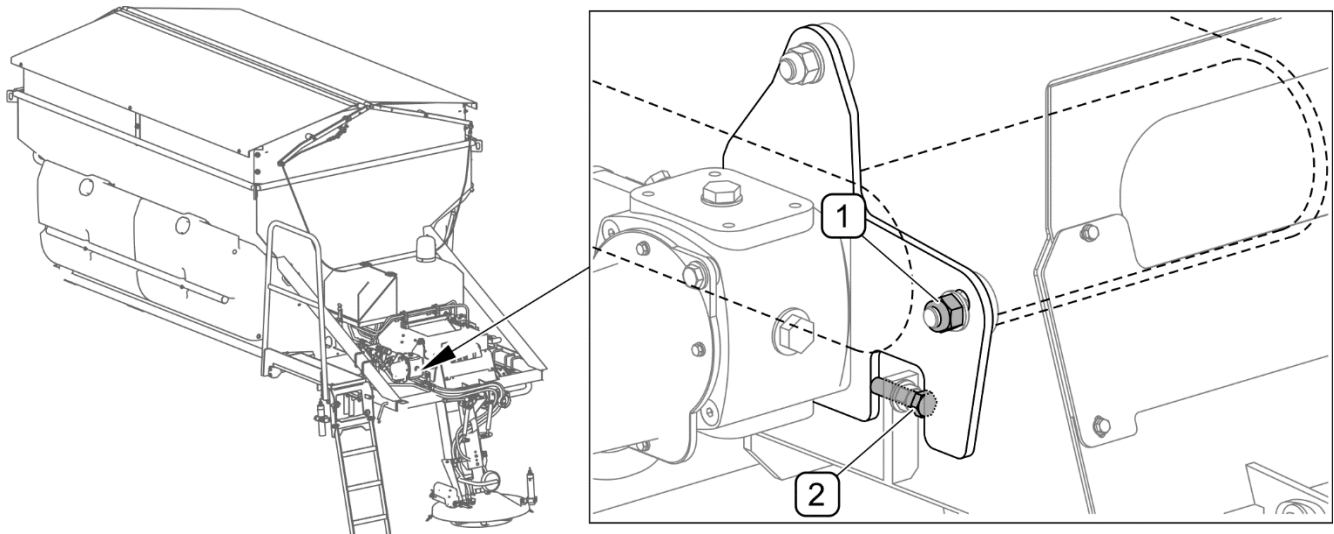

FIG. 5.6 Adjustment of drive roller

(1) - locking nut; (2) - adjusting screw

If the conveyor belt is shifted sideways to the edge of the conveyor drive roller (FIG. 5.6), make proper adjustment of the roller. The adjustment is made only on one side of the conveyor using bolt (2) by changing the position of the roller drive transmission bracket. Start the carrying vehicle's external hydraulic circuit that supplies the machine. Activate "Unloading" function in "Counters" menu on the control panel. A detailed description can be found in section 4.9 UNLOADING. Loosen nut (1) and position the belt in the middle of the roller by means of adjustment bolt (2). During the adjustment, make one turn of bolt (2) and wait for some time to see the effect of the adjustment. Repeat the activity until moving conveyor belt is positioned in the middle of the conveyor roller. After adjustment, disengage conveyor drive, tighten nut (1).

5.3.3 INSPECTION AND REPLACEMENT OF CONVEYOR BELT BRUSHES



DANGER

Before inspection or replacement of conveyor brushes, turn off the carrying vehicle's engine and secure the vehicle's cab against access of third persons.

Brushes are used for collecting remains of spreading material from conveyor belt. Belt conveyor is equipped with two brushes located under the belt, near the chute. Degree of wear of brushes should be checked periodically. Brushes should be pressed against the whole width of the lower side of the conveyor belt. In the event of confirmation of wear of the brushes, they must be replaced.



Regularly check the condition of brushes under the conveyor belt. In the event of confirmation of excessive wear of the brushes, they must be replaced.

The brushes should be inspected at least once a month during the working season.

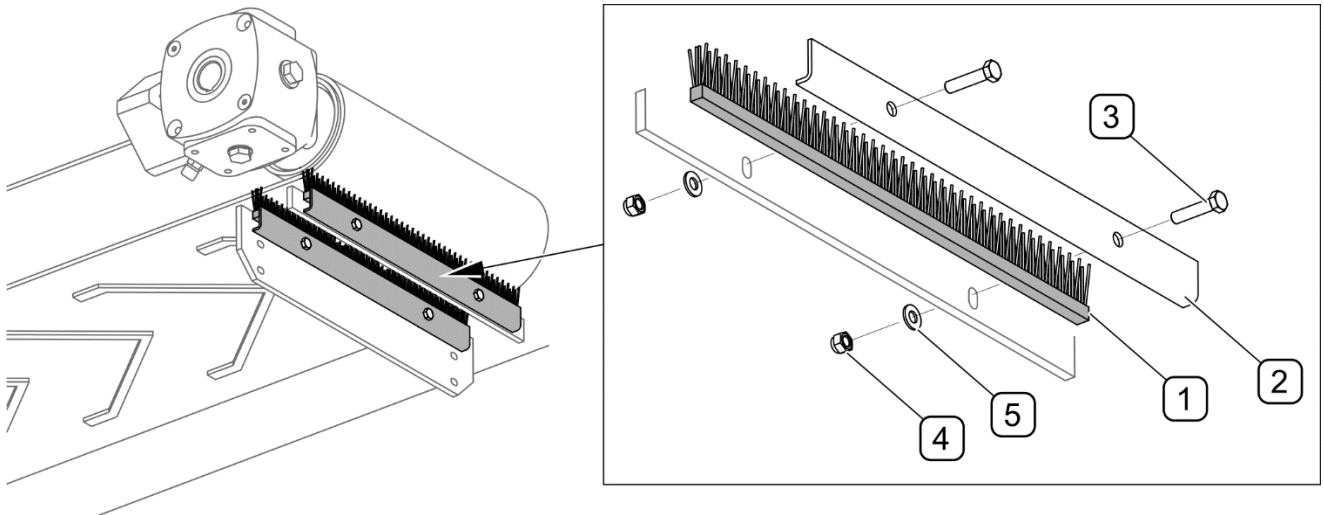

FIG. 5.7 Replacement of conveyor belt brushes

(1) - brush; (2) - clamping strip; (3) - M8x35-A2-70 bolt; (4) - M8-A4-70 nut; (5) - washer 8-200HV-A2



TIP

Belt conveyor is equipped with two replaceable brushes with the length of $L = 400$ mm, part number STL4999-255662, located under the drive roller.

To replace the brushes (FIG. 5.7):

- remove clamping strip (2) by unscrewing bolts (2),
- remove worn or damaged brush (1) and replace it with a new one,
- set the brush in parallel to the belt,
- assemble the complete unit performing the above activities in reverse sequence,
- replace the second brush in the same way

5.4 MAINTENANCE OF BRINE SPRAY SYSTEM

Maintenance of brine spray system involves periodical cleaning of filter, checking operation and tightness of the system.



Before filling the brine tank check and if necessary tighten the screws that mount the tank to the frame

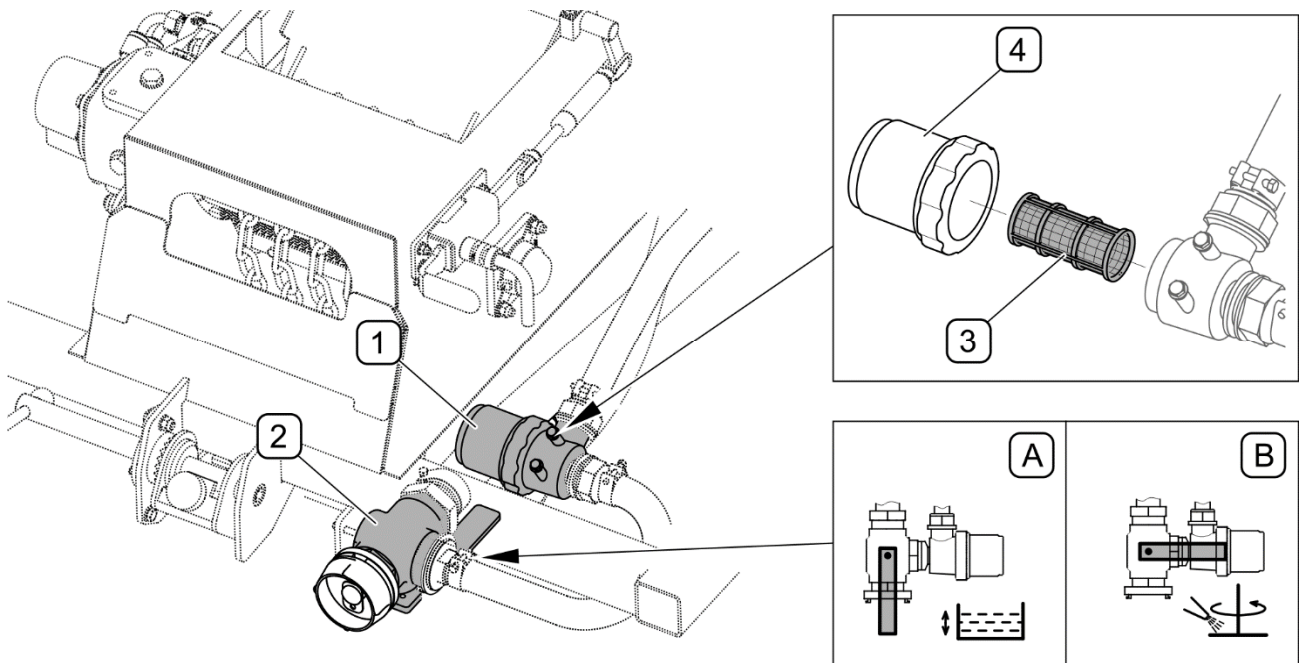



FIG. 5.8 Brine filter cleaning

(1) - brine filter; (2) - valve; (3) - mesh cartridge of filter; (4) - filter housing; (A) - valve in position "filling/emptying"; (B) - valve in position "brine spraying"



TIP

It is recommended to maintain such a level of brine as to ensure that the pump is filled with the solution at all times. This prevents corrosion of internal pump components and facilitates suction of fluid in the beginning of spraying.

In order to clean brine filter (1):

- Set valve in position (A) "filling/emptying".
- Unscrew filter housing (4).
- Remove filter cartridge (3) and wash it in water.

- Install the cartridge and tighten filter housing (4).
- Set valve in position (B) "brine spraying".

**TIP**

Filter of brine spray system is equipped with reusable mesh cartridge with part number of C00100036.

In the event of damage to the cartridge, replace it with a new one.



Brine filter cartridge should be cleaned at least once a month during the working season.

5.5 ADJUSTMENT OF SPREADING MECHANISM

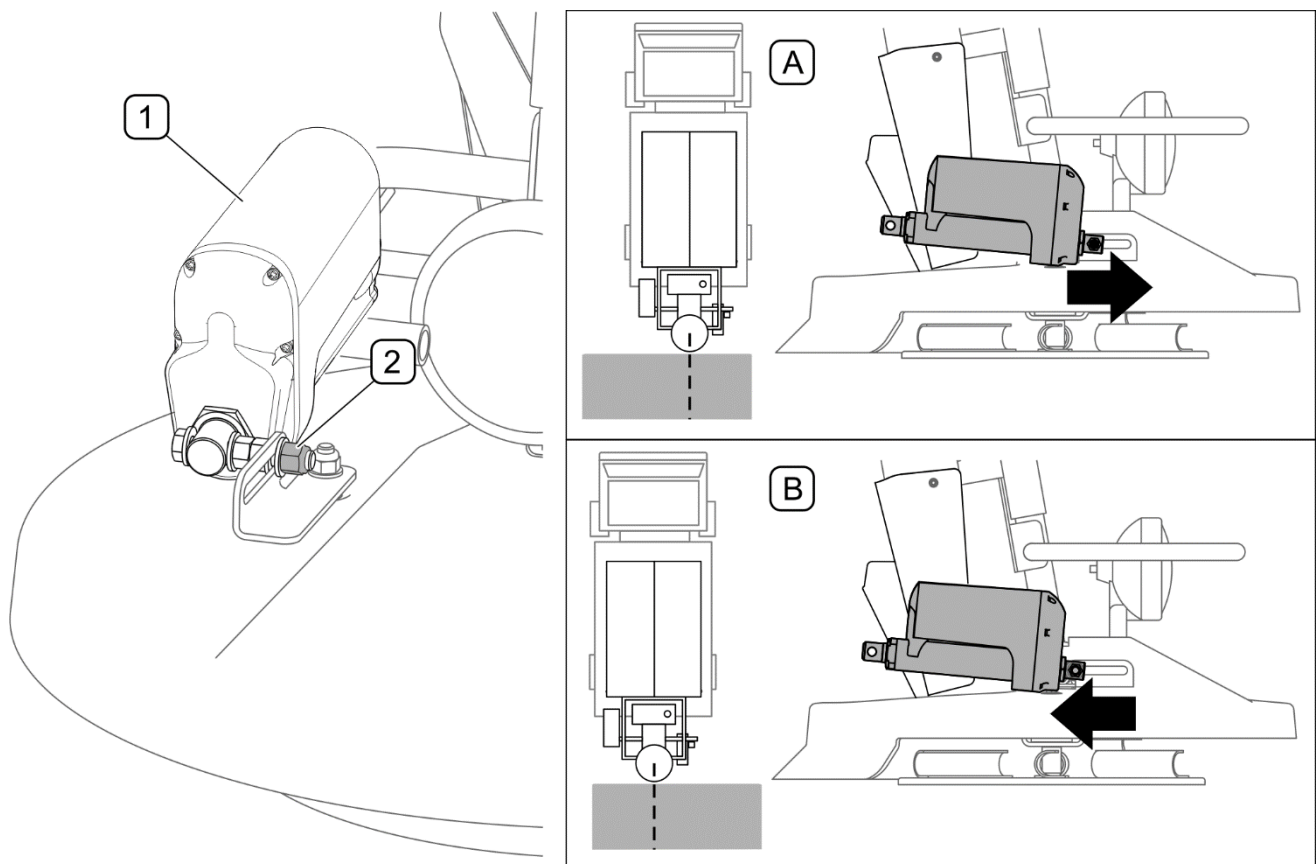

FIG. 5.9 Adjustment of spreading mechanism

(1) - spreading direction adjusting cylinder; (2) - nut; (A) - spreading zone excessively shifted to the left, (B) - spreading zone excessively shifted to the right,

If there are differences in spreading symmetry during spreading mechanism operation, with regard to values set on the control panel, it may be necessary to adjust the setting of the electric cylinder.

In order to adjust the spreading mechanism, set symmetric 4 meter-wide spreading zone on the control panel. Activate spreading and drive a short distance at a constant speed. Stop the vehicle and check effect of spreading. If spreading to the right side and to the left side is not the same, adjust spreading direction adjusting cylinder (1) (FIG. 5.9) as follows:

- Loosen nut (2).
- Move cylinder (1) forwards if spreading zone is excessively shifted to the left (A).
- Move cylinder (1) backwards if spreading zone is excessively shifted to the right (B).
- Tighten nut (2), conduct test spreading, if necessary, repeat the adjustment.

5.6 REPLACING SPREADING DISC BLADES

Technical condition of spreading mechanism disc blades should be checked periodically paying attention to mechanical damage, excessive wear and completeness of securing elements.



DANGER

Spreading disc blades may be checked and replaced only if the machine is switched off and secured.

In order to replace a spreading disc (FIG. 5.10) blade:

- undo nuts (3),
- remove bolts (2) and washers (4),
- replace blades (1) with new ones, check condition of bolts and nuts, if necessary replace (see TAB. 5.3)
- install in reverse order,

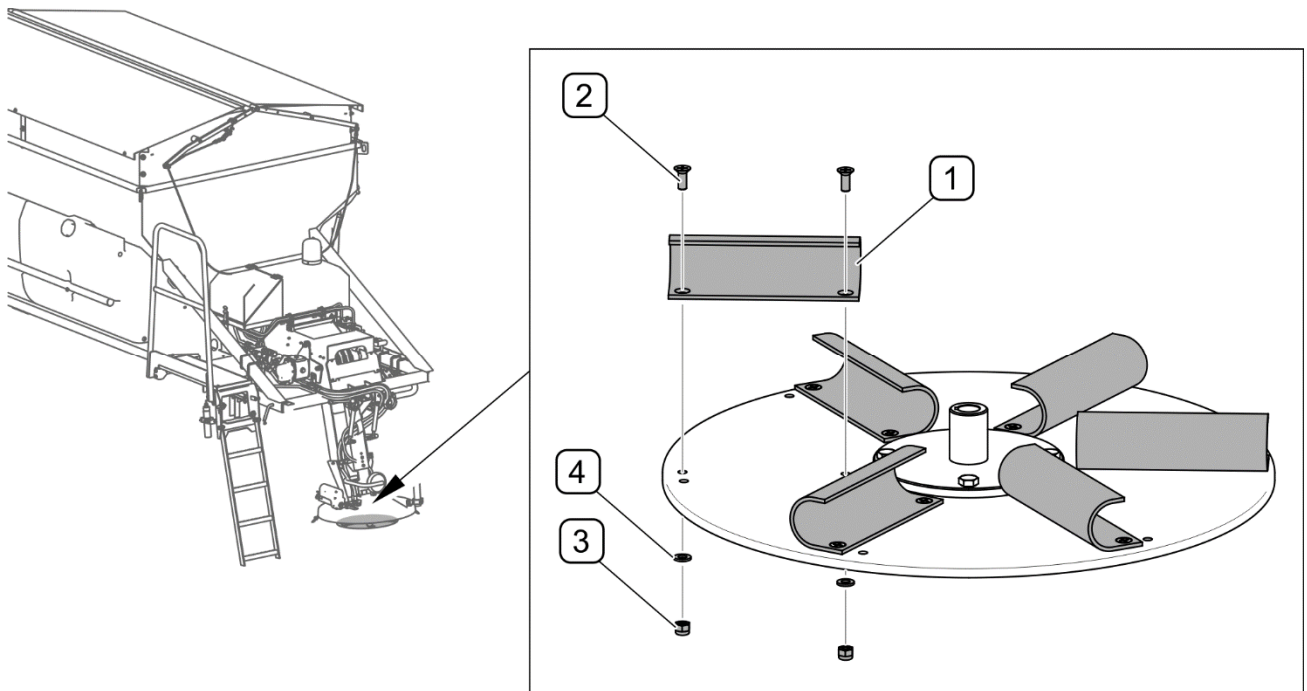

FIG. 5.10 Replacement of spreading mechanism disc blades

(1) - blade; (2) - bolt; (3) - nut; (4) - washers

TAB. 5.3 THE LIST OF WORKING COMPONENTS OF SPREADING DISC

Marking FIG. 5.10	Name / Catalogue No.	Number of items
1	Blade / 254-07000001	6
2	Bolt M6x16-A2-70 / PN-EN ISO 7046-2	12
3	Self locking nut M6-A4-70 PN-EN ISO 7040	12
4	Washer 6-200HV-A2 PN-EN ISO 7089	12

5.7 LUBRICATION

Before commencing lubrication insofar as is possible remove old grease and other contamination. Remove and wipe off excess oil or grease.



When using the machine the user is obliged to observe lubrication instructions according to attached schedule. Excess lubrication substance causes depositing additional contaminants in places requiring lubrication, therefore it is essential to keep individual machine elements clean.

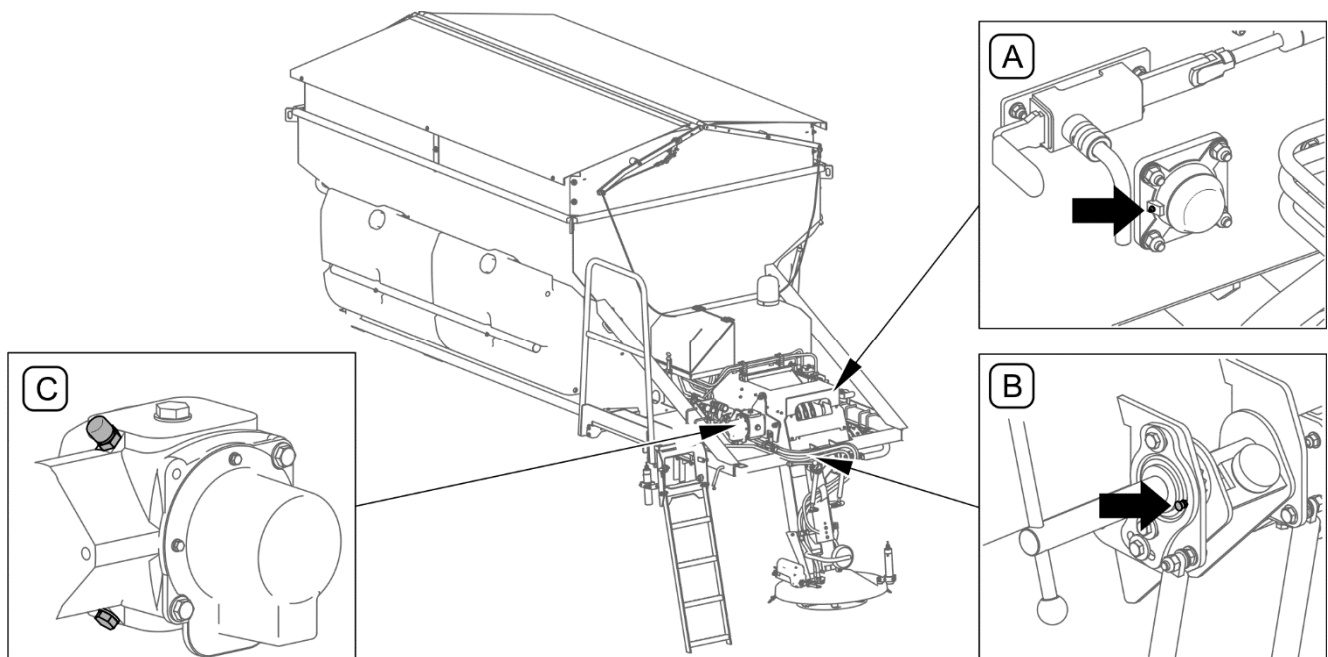

FIG. 5.11 Lubrication points

Lubrication points described in table 5.3

TAB. 5.4 LUBRICATION POINTS AND LUBRICATION FREQUENCY

ITEM	NAME	NUMBER OF LUBRICATION POINTS	TYPE OF GREASE	LUBRICATION FREQUENCY
A	Bearing of belt conveyor drive shaft	1	grease	every 20 hours of work
B	Pivot point of hopper system	1	grease	once a month
C	Conveyor drive transmission	1	oil	inspect once a year

Marking description in Item column (TAB. 5.4) conforms with numbering shown (FIG. 5.11)

5.8 STORAGE

After finishing work, machine should be thoroughly cleaned and washed with water jet.

After completed work, check and possibly remove material accumulated near the tightening roller and on the internal surface of the conveyor belt.

While washing do not direct a strong water or steam jet at information and warning decals or hydraulic conduits. Nozzle of pressure or steam washer should be kept at a distance of not less than 30 cm from cleaned surface.

After cleaning, inspect the whole machine, inspect technical condition of individual elements. Used or damaged elements should be repaired or replaced.

In the event of damage to the paint coat, clean rust and dust from damaged area, degrease and then paint with undercoat and after it is dry paint with surface coat paint retaining colour uniformity and even thickness of protective coating. Until the time of touch-up painting, the damaged place may be covered with a thin layer of grease or anticorrosion preparation. Machine should be kept in closed or roofed building.

If the machine shall not be used for a long period of time, protect it against adverse weather conditions. Disconnect control panel from the machine.

Lubricate machine according to the instructions provided. In the event of prolonged work stoppage, it is essential to lubricate all elements regardless of the period of the last lubrication process.

The sand spreader's tank should be emptied and covered with tarpaulin cover.



ATTENTION!

Remains of material containing salt cause quick corrosion of metal parts.

5.9 TIGHTENING TORQUE FOR NUT AND BOLT CONNECTIONS

During maintenance and repairs use appropriate torque for bolt connections (unless other is specified for a particular connection). Recommended torque values apply to non-greased steel bolts (TAB. 5.5)

TAB. 5.5 TIGHTENING TORQUE FOR NUT AND BOLT CONNECTIONS

THREAD DIAMETER [mm]	5.8	8.8	10.9
	TIGHTENING TORQUE [Nm]		
M6	8	10	15
M8	18	25	36
M10	37	49	72
M12	64	85	125
M14	100	135	200
M16	160	210	310
M20	300	425	610
M24	530	730	1,050



ATTENTION!

Should it be necessary to change individual parts, use only original parts or those indicated by the Manufacturer. Non-adherence to these requirements may put the user and other people's health and life at risk, and also damage the machine.

5.10 TROUBLESHOOTING

TAB. 5.6 TROUBLESHOOTING

TYPE OF FAULT	CAUSE	REMEDY
Control panel is not working	Main switch of control panel is off	Turn on the main switch (power supply)
	Electric lead is disconnected from control panel	Connect the power supply to control panel
	Burnt out fuse	Replace
	No contact in electrical connections	Clean or replace a connection
Belt conveyor does not move or does not move smoothly	Oil level in carrying vehicle hydraulic system is too low	Check and add oil if necessary
	Too slack belt is slipping on drive roller	Adjust according to operator's manual
	Hydraulic system is damaged	Repair at authorised service point
	Damaged transmission of conveyor belt drive	Repair at authorised service point
Hydraulic system works incorrectly	Oil level in carrying vehicle hydraulic system is too low	Check and add oil if necessary
	Leakage in hydraulic system	Check and correct the fault
Spreading disk works incorrectly	See " <i>Wrong operation of hydraulic system</i> "	See " <i>Wrong operation of hydraulic system</i> "
	Damaged hydraulic motor of spreading disc drive	Repair at authorised service point
Brine spray system does not work	Brine level in tanks is too low	Check brine level on the brine level indicator, supplement brine.
	Brine valve is set in position " <i>filling/emptying</i> "	Set valve in " <i>brine spraying</i> " position
	Oil level in system is too low	Check oil level in the carrying vehicle's system, add oil if necessary.
	Leakage in hydraulic system	Check and correct the fault
	Clogged brine filter	Check and clean if necessary
	Brine pump drive damaged	Repair at authorised service point
	Leakage in hydraulic system	Check and correct the fault
Incorrect spreading of material	Incorrect machine settings	Set the belt conveyor barrier in a manner suitable for a given type of spreading material, conduct a test and correct settings.
	Electrical spreading direction adjusting cylinder is incorrectly set	Check and adjust according to operator's manual
	Damaged relay in fuse box	Replace
	Damaged spreading disc blades	Replace
Lights do not work	Burned-out bulb	Replace
	Damaged relay	Replace

NOTES

A series of horizontal dotted lines for writing notes.