



PRONAR Sp. z o.o.

17-210 NAREW, UL. MICKIEWICZA 101A, PODLASKIE PROVINCE

phone:	+48 085 681 63 29	+48 085 681 64 29
	+48 085 681 63 81	+48 085 681 63 82
fax:	+48 085 681 63 83	+48 085 682 71 10

www.pronar.pl

OPERATOR'S MANUAL

CUTTING HEAD

PRONAR GK110 / PRONAR GK140

TRANSLATION OF THE ORIGINAL COPY OF THE MANUAL

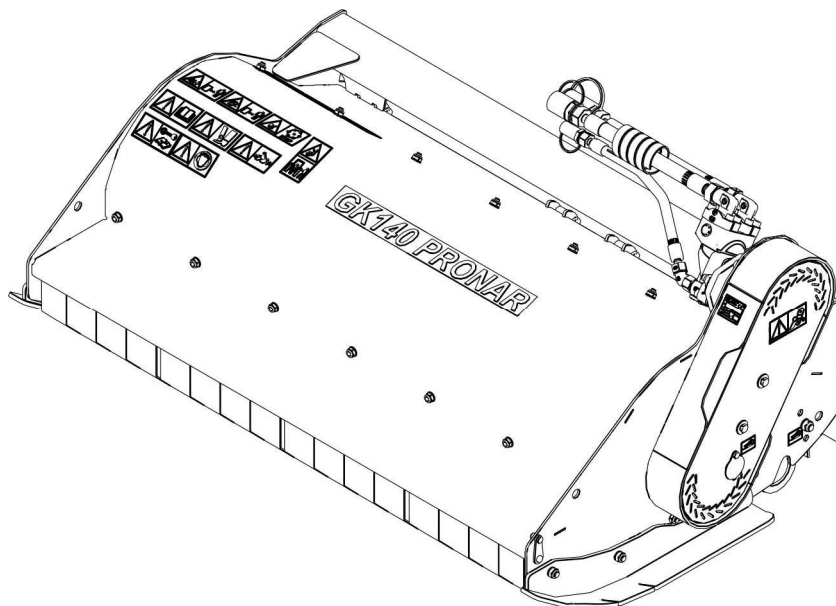

EDITION 1A-09-2012

PUBLICATION NO 265N-00000000-UM

EN

INTRODUCTION

Information contained herein is current at date of publication. As a result of improvements, some numerical values and illustrations contained in this publication may not correspond to the factual specification of the machine supplied to the user. The manufacturer reserves the right to introduce design changes in machines produced that facilitate operation and improve the quality of their work, without making minor amendments to this Operator's Manual.

This Operator's Manual is an integral part of the machine's documentation. Before using the machine, the user must carefully read this Operator's Manual and observe all recommendations. This guarantees safe operation and ensures malfunction free work of the machine. The machine is designed to meet obligatory standards, documents and legal regulations currently in force.

The manual describes the basic safety rules and operation of PRONAR GK110 / GK140 cutting heads. If the information stated in the Operator's Manual needs clarification then the user should refer for assistance to the sale point where the machine was purchased or to the Manufacturer.

MANUFACTURER'S ADDRESS:

*PRONAR Sp. z o.o.
ul. Mickiewicza 101A
17-210 Narew*

CONTACT TELEPHONES

+48 085 681 63 29

+48 085 681 64 29

+48 085 681 63 81

+48 085 681 63 82

SYMBOLS APPEARING IN THIS OPERATOR'S MANUAL

Information, descriptions of danger and precautions and also recommendations and prohibitions associated with user safety instructions are marked:



and also preceded by the word "**DANGER**". Failure to observe the instructions may endanger the machine operator's or other person's health or life.

Particularly important information and instructions, the observance of which is essential, are distinguished in the text by the sign:



and also preceded by the word "**ATTENTION**". Failure to observe the instructions may lead to damage to the machine as a result of improper operation, adjustment or use.

In order to focus the user's attention on the need to perform maintenance, the relevant section of the Operator's Manual is marked with the pictogram:



Additional tips and advice for machine operation are marked:



and also preceded by the word "**TIP**".

DIRECTIONS USED IN THIS OPERATOR'S MANUAL

Left side – side to the left hand of the operator facing in the direction of machine's forward travel.

Right side – side to the right hand of the operator facing in the direction of machine's forward travel.



PRONAR Sp. z o.o.

ul. Mickiewicza 101 A
17-210 Narew, Polska

tel./fax (+48 85) 681 63 29, 681 63 81, 681 63 82,
681 63 84, 681 64 29

fax (+48 85) 681 63 83

http://www.pronar.pl

e-mail: pronar@pronar.pl

EC DECLARATION OF CONFORMITY OF THE MACHINERY

PRONAR Sp. z o.o. declares with full responsibility, that the machine:

Description and identification of the machinery		
Generic denomination and function:	Cutting head	
Type:	GK110	GK140
Model:	—	—
Serial number:		
Commercial name:	Cutting head PRONAR GK110 Cutting head PRONAR GK140	

to which this declaration relates, fulfills all the relevant provisions of the Directive **2006/42/EC** of The European Parliament and of The Council of 17 May 2006 on machinery, and amending Directive 95/16/EC (Official Journal of the EU, L 157/24 of 09.06.2006).

The person authorized to compile the technical file is the Head of Research and Development Department at PRONAR Sp. z o.o., 17-210 Narew, ul. Mickiewicza 101A, Poland.

This declaration relates exclusively to the machinery in the state in which it was placed on the market, and excludes components which are added and/or operations carried out subsequently by the final user.

Narew, the 2011-03-24

Place and date

Z-CIA DYREKTORA
d/s technicznych
członek zarządu

Roman Gmieniuk

*Full name of the empowered person
position, signature*

TABLE OF CONTENTS

1	BASIC INFORMATION	1.1
1.1	IDENTIFICATION	1.2
1.2	PROPER USE	1.3
1.3	EQUIPMENT	1.5
1.4	TERMS & CONDITIONS OF WARRANTY	1.5
1.5	TRANSPORT	1.6
1.6	ENVIRONMENTAL HAZARDS	1.7
1.7	WITHDRAWAL FROM USE	1.8
2	SAFETY ADVICE	2.1
2.1	BASIC SAFETY RULES	2.2
2.1.1	USE OF MACHINE	2.2
2.1.2	LINKING AND DISCONNECTING FROM TRACTOR	2.3
2.1.3	HYDRAULIC SYSTEM	2.3
2.1.4	TRANSPORTING THE MACHINE	2.4
2.1.5	MAINTENANCE	2.5
2.1.6	CUTTING HEAD OPERATION	2.7
2.2	DESCRIPTION OF MINIMAL RISK	2.8
2.3	INFORMATION AND WARNING DECALS	2.9
3	DESIGN AND OPERATION	3.1
3.1	TECHNICAL SPECIFICATION	3.2
3.2	GENERAL DESIGN	3.3
3.3	DRIVE TRANSMISSION	3.4
3.4	CUTTING UNIT	3.5

4	CORRECT USE	4.1
4.1	PREPARING FOR WORK	4.2
4.2	CHECKING TECHNICAL CONDITION	4.5
4.3	HITCHING TO MULTIFUNCTION ARM	4.6
4.4	TRANSPORTING THE MACHIN	4.7
4.5	SETTING AND MOWING	4.8
4.5.1	SETTING THE MOWER IN WORKING POSITION	4.8
4.5.2	SETTING CUTTING HEIGHT	4.10
4.5.3	MOWING	4.11
4.5.4	REMOVING BLOCKAGES	4.13
4.6	UNHITCHING FROM MULTIFUNCTION ARM	4.13
5	MAINTENANCE	5.1
5.1	INSPECTION AND DISASSEMBLY OF SAFETY GUARDS	5.2
5.2	CHECKING AND REPLACING FLAIL BLADES	5.4
5.3	DRIVE SYSTEM MAINTENANCE	5.6
5.4	STORAGE	5.8
5.5	LUBRICATION	5.9
5.6	TIGHTENING TORQUE FOR NUT AND BOLT CONNECTIONS	5.11
5.7	TROUBLESHOOTING	5.12

SECTION

1

BASIC INFORMATION

1.1 IDENTIFICATION

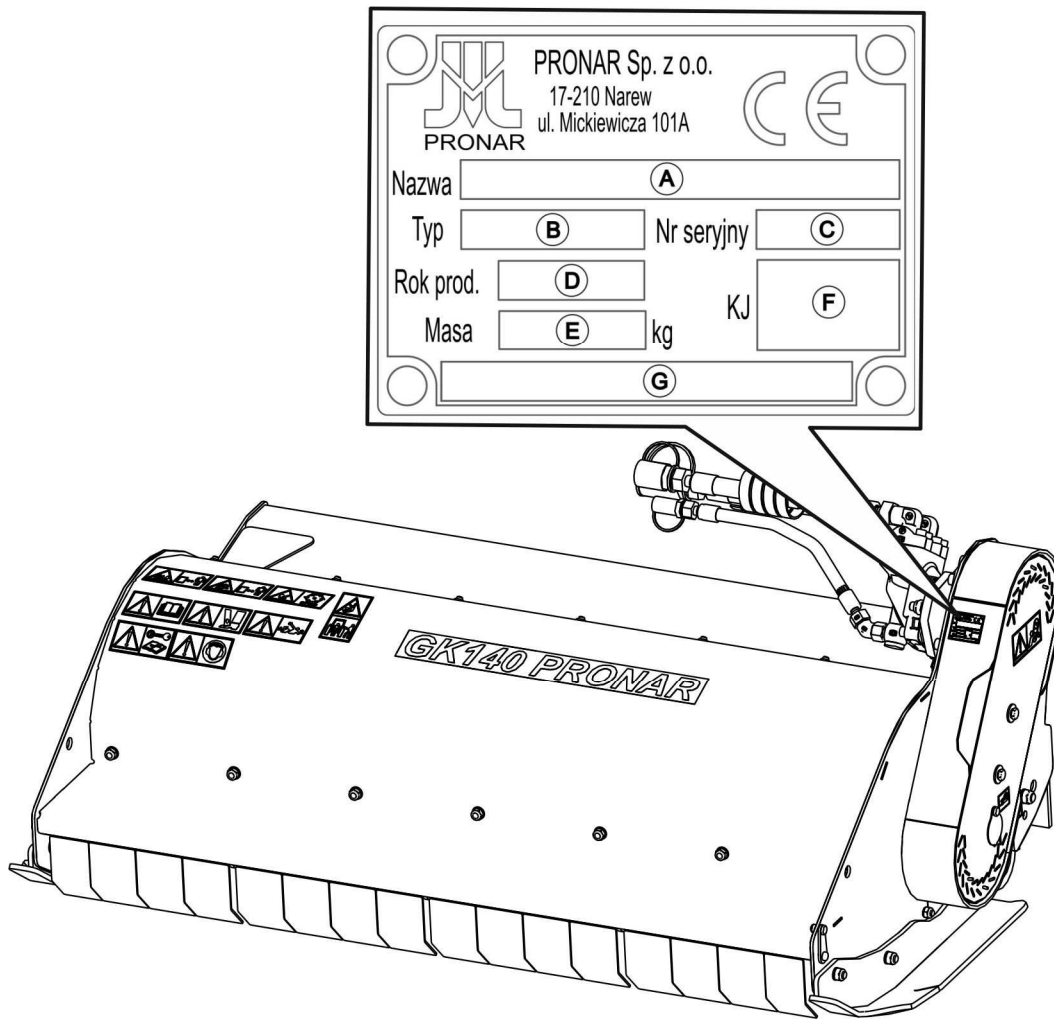

FIG. 1.1 Location of the data plate.

PRONAR GK110 / GK140 cutting heads are marked with the data plate located on the belt transmission housing. When buying the machine check that the serial numbers on the machine agree with the number written in the *WARRANTY BOOK*, in the sales documents and in the *OPERATOR'S MANUAL*.

The meanings of the individual fields found on the data plate (FIGURE 1.1) are presented in the table below:

A - machine name, B - machine type/symbol
C – serial number, D – year of manufacture,
E - tare weight [kg], F – Quality control stamp,
G – machine name, name extension

1.2 PROPER USE



IMPORTANT!

Cutting head PRONAR GK110 / GK140 cooperates with multifunction arm PRONAR WWP600, WWP500, WWP500U or WWP500UH.

Cutting head on multifunction arm WWP600 / WWP500 / WWP500U / WWP500UH is used for mowing grass, cutting all kinds of bushes and breaking up cut tree branches. Design of multifunction arm enables operation in hard to reach areas such as roadside ditches behind protective barriers, slopes, drainage ditches, roadsides. The cutting head is mounted on the self aligning multifunction floating arm for perfect ground surface tracking. The cutting head leaves the cutting area with evenly ground material, which also forms a fertilising layer.

Transporting people, animals or other materials on the cutting head is forbidden and regarded as contrary to the intended purpose. During the use of the machine comply with all road traffic regulations and transport regulations in force in the given country, and any breach of these regulations is regarded by the Manufacturer as use contrary to its intended purpose.



IMPORTANT!

The cutting head must not be used for purposes other than those for which it is intended, in particular:

- for transporting people and animals,
- for transport of whatever materials or objects.

Using it as intended involves all actions connected with the safe and proper operation and maintenance of the machine. In connection with this the user is obliged to:

- carefully read the *OPERATOR'S MANUAL* and comply with its recommendations,
- understand the machine's operating principle and how to operate it safely and correctly,

- adhere to the established maintenance and adjustment plans,
- comply with general safety regulations while working,
- prevent accidents,
- comply with the road traffic regulations and transport regulations in force in a given country, in which the machine is used,
- carefully read the Operator's Manual of the agricultural tractor and the Operator's Manual of the multifunction arm and comply with their recommendations.

The cutting head may only be used by persons, who:

- are familiar with the contents of this publication and with the contents of the Operator's Manual of the agricultural tractor and the Operator's Manual of the multifunction arm,
- have been trained in cutting head operation and safe operation,
- have the required authorisation to drive and are familiar with the road traffic regulations and transport regulations.

1.3 EQUIPMENT

TAB. 1.1 Equipment of PRONAR GK110 / GK140 cutting head

EQUIPMENT	STANDARD	OPTION
Operator's Manual	•	
Warranty book	•	

1.4 TERMS & CONDITIONS OF WARRANTY

PRONAR Sp. z o.o., Narew guarantees the reliable operation of the machine when it is used according to its intended purpose as described in the *OPERATOR'S MANUAL*. Defects discovered during the warranty period will be removed by the Warranty Service. The repair period is specified in the *WARRANTY BOOK*.

The warranty does not apply to those parts and sub-assemblies of the machine, which are subject to wear in normal usage conditions, regardless of the warranty period. Consumables include the following parts/sub-assemblies:

- flail blades,
- rubber and metal guards,
- bearings.

The warranty service only applies to factory defects and mechanical damage that is not due to the user's fault.

In the event of damage arising from:

- mechanical damage which is the user's fault, caused by road accidents,
- by inappropriate use, adjustment or maintenance, use of the cutting head for purposes other than those for which it is intended,
- use of damaged machine,
- repairs carried out by unauthorised persons, improperly carried out repairs,
- making unauthorised alterations to machine design,

the user will lose the right to warranty service.

**TIP**

Demand that the seller carefully and precisely fills out the Warranty Book and warranty repair coupons. A missing date of purchase or sale point stamp, may make the user ineligible for any warranty repair or refund.

The user is obliged to report immediately on noticing any wear in the paint coating or traces of corrosion, and to have the faults rectified whether they are covered by the warranty or not. For detailed Terms & Conditions of Warranty, please refer to the WARRANTY BOOK attached to each machine.

Modification of the cutting head without the written consent of the Manufacturer is forbidden. In particular, do NOT weld, drill holes in, cut or heat the main structural elements of the machine, which have a direct impact on the machine operation safety.

1.5 TRANSPORT

The cutting head is ready for sale completely assembled and does not require packing. Packing is only required for the machine's technical documentation and any extra fittings.

**IMPORTANT!**

Before transporting independently, the tractor driver must carefully read this operator's manual and observe its recommendations. When being transported on a motor vehicle the cutting head must be mounted on the vehicle's platform in accordance with the transport safety requirements. The driver of the vehicle should take particular care while driving. This is due to the vehicle's centre of gravity shifting upwards when loaded with the machine.

Delivery is either by transport on a vehicle or independently, after being attached to a tractor. Transport of the cutting head connected to the multifunction arm is allowed provided that the tractor driver is familiar with the Operator's Manual of the cutting head and the Operator's Manual of the multifunction arm, in particular, with information concerning safety and principles of hitching and transport of the cutting head on public roads. Do NOT drive the tractor with the multifunction arm and the cutting head connected when visibility is limited.

When loading and unloading the cutting head, comply with the general principles of workplace health and safety for reloading work. Persons operating reloading equipment must have the qualifications required to operate these machines.

The machine should be attached firmly to the platform of the vehicle using straps or chains fitted with a tightening mechanism. The fastening equipment used must have a valid safety

certificate. Exercise particular caution when lifting the machine. To keep lifted machine in the correct direction it is recommended to apply additional guy cables. During the loading work particular care should be taken not to damage paint coating.



IMPORTANT!

Nobody may be in the manoeuvring zone during transferring cutting head to other form of transport.

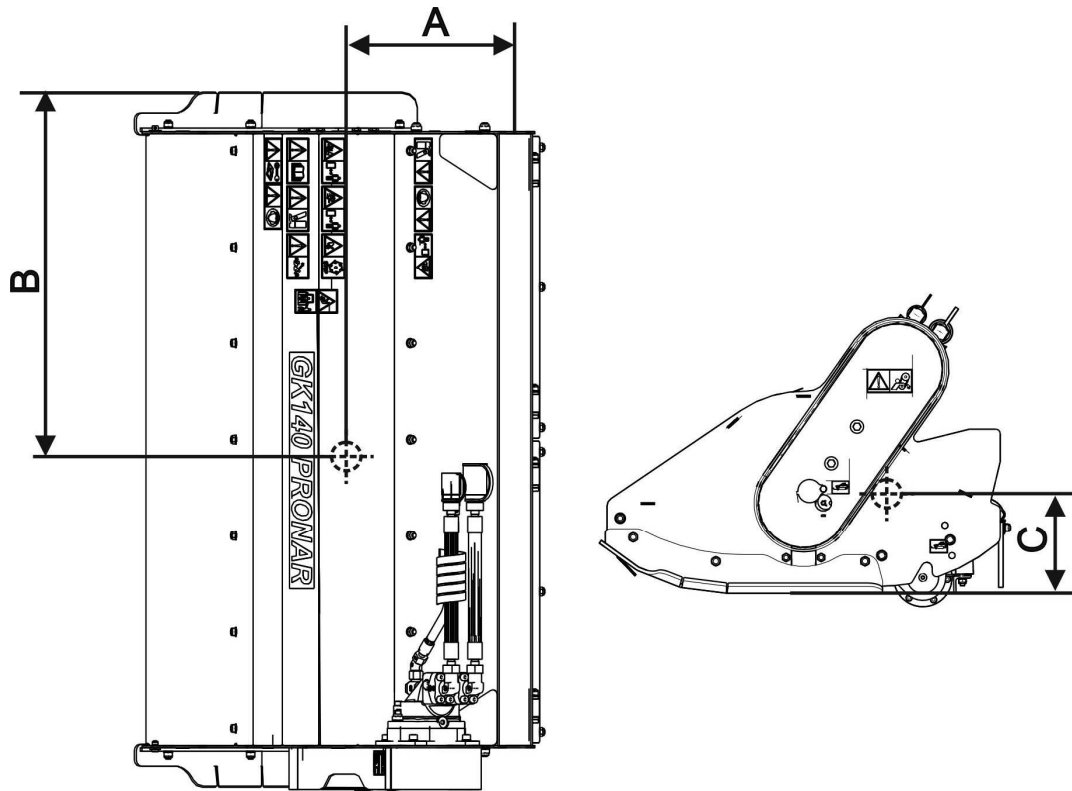

FIG. 1.2 Location of centre of gravity of the cutting head.

TAB. 1.2 Centre of gravity.

Dimension (FIGURE 1.2)	Unit	Mower model	
		GK110	GK140
A	mm	325	325
B	mm	770	880
C	mm	230	230

1.6 ENVIRONMENTAL HAZARDS

A hydraulic oil leak constitutes a direct threat to the natural environment owing to its limited biodegradability. While carrying out maintenance and repair work which involves the risk of an oil leak, this work should take place on an oil resistant floor or surface. In the event of oil leaking into the environment, first of all contain the source of the leak, and then collect the leaked oil using available means. Remaining oil should be collected using sorbents, or by mixing the oil with sand, sawdust or other absorbent materials. The oil pollution, once gathered up, should be kept in a sealed, marked, hydrocarbon resistant container, and then passed on to the appropriate oil waste recycling centre. The container should be kept away from heat sources, flammable materials and food.

Oil, which has been used up or is unsuitable for further use owing to a loss of its properties should be stored in its original packaging in the conditions described above.

1.7 WITHDRAWAL FROM USE

In the event of decision by the user to withdraw the machine from use, comply with the regulations in force in the given country concerning withdrawal from use and recycling of machines withdrawn from use.

Before proceeding to dismantle equipment, oil shall be completely removed from hydraulic system and transmission. Locations of drain plugs and method for draining oil are described in Section 5.

When spare parts are changed, worn out or damaged parts should be taken to a collection point for recyclable raw materials. Waste oil and also rubber and plastic elements should be taken to establishments undertaking the utilisation of such waste.



IMPORTANT!

During dismantling personal protection equipment shall be used i.e. protective clothing, boots, gloves and protective goggles etc.

Avoid contact of skin with oil. Do not allow used oil to spill.

SECTION

2

SAFETY ADVICE

2.1 BASIC SAFETY RULES

2.1.1 USE OF MACHINE

- Before using the machine, the user must carefully read this Operator's Manual and the *WARRANTY BOOK*. When operating the machine, the operator must comply with the recommendations.
- The cutting head may only be used and operated by persons qualified to drive agricultural tractors and agricultural machines and trained in the use of the machine. The cutting head can be operated by a single person only.
- If the information stated in the Operator's Manual is difficult to understand, contact a seller, who runs an authorised technical service on behalf of the manufacturer, or contact the manufacturer directly.
- Careless and improper use and operation of the machine, and non-compliance with the recommendations given in this operator's manual is dangerous to your health.
- Be aware of the existence of a minimal risk, and for this reason the fundamental basis for using this cutting head should be the application of safety rules and sensible behaviour.
- The machine must never be used by persons, who are not authorised to drive agricultural tractors, including children and people under the influence of alcohol or other drugs.
- Non-compliance with the safety rules of this Operator's Manual can be dangerous to the health and life of the operator and others.
- The machine must not be used for purposes other than those for which it is intended. Anyone who uses the cutting head other than the way intended takes full responsibility for himself for any consequences of this use. Use of the machine for purposes other than those for which it is intended by the Manufacturer may invalidate the warranty.
- The cutting head may only be used when all the safety guards and other protective elements are technically sound and correctly positioned. In the event of loss or destruction of the safety guards, they must be replaced with new ones.

- In order to limit occupational risks associated with exposure to noise during cutting head operation use individual protection (ear protectors). In order to reduce the level of noise during work the tractor cab window and door should be closed.

2.1.2 LINKING AND DISCONNECTING FROM TRACTOR

- Do NOT connect the cutting head to a multifunction arm of other type than the recommended by the manufacturer (PRONAR WWP600 / WWP500 / WWP500U / WWP500UH).
- After mounting the machine, check the safeguards. Carefully read the tractor Operator's Manual.
- Use only original bolts and protections to hitch the cutting head to the multifunction arm.
- The multifunction arm to which the cutting head will be hitched must be technically reliable and must fulfil the requirements of the cutting head Manufacturer.
- Be especially careful when hitching the machine.
- When hitching, there must be nobody between the cutting head and the multifunction arm and the tractor.
- Do NOT unhitch the cutting head from the multifunction arm if the cutting system is raised. Exercise caution when disconnecting the cutting head.
- Hitching and unhitching may only take place when the cutting head and the tractor are switched off.
- The cutting head disconnected from the multifunction arm must be placed in a stable manner on level surface.

2.1.3 HYDRAULIC SYSTEM

- The hydraulic system is under high pressure when operating.
- Regularly check the technical condition of the connections and the hydraulic lines. There must be no oil leaks.
- In the event of malfunction of the hydraulic system, the machine shall be disconnected from use until the malfunction is corrected.
- When connecting the hydraulic conduits to the hydraulic motor, make sure that the hydraulic system of the multifunction arm is not under pressure. If necessary reduce residual pressure in the system.
- In the event of injuries being caused by pressurised hydraulic oil, contact a doctor immediately. Hydraulic oil may find its way under the skin and cause infections. In the event of contact of oil with eye, rinse with large quantity of water and in the event of the occurrence of irritation consult a doctor. In the event of contact of oil with skin wash the area of contact with water and soap. Do NOT apply organic solvents (petrol, kerosene).
- Use the hydraulic oil recommended by the Manufacturer. Never mix two types of oil.
- After changing the hydraulic oil, the used oil should be properly disposed of. Used oil or oil, which has lost its properties, should be stored in original containers or replacement containers resistant to action of hydrocarbons. Replacement containers must be clearly marked and appropriately stored.
- Do not store hydraulic oil in packaging designed for storing food or foodstuffs.
- Rubber hydraulic conduits must be replaced every 4 years regardless of their technical condition.
- Repair and replacement of hydraulic system elements should be entrusted to the appropriately qualified persons.

2.1.4 TRANSPORTING THE MACHINE

- When driving on public roads, comply with the road traffic regulations. in force in the country, in which the machine is used.
- Do not exceed the permitted speed arising from road conditions and design limitations. Adjust travel speed to the prevailing road conditions and other limitations arising from road traffic regulations limits.
- Before driving off, the cutting head must be folded to transport position and mounted on the hitch of the multifunction arm.
- Do NOT leave machine raised and unsecured while the tractor is parked. When parked, the machine should be lowered.
- Do not transport the machine with the cutting assembly set in the working position.
- The cutting head may not be used or transported in conditions of limited visibility.
- Do NOT ride on the machine or transport any materials on it.
- Before using the machine always check its technical condition, especially in terms of safety. In particular, check the technical condition of the hitch system, the cutting system and elements connecting hydraulic system.
- Reckless driving and excessive speed may cause accidents.

2.1.5 MAINTENANCE

- During the warranty period, any repairs may only be carried out by Warranty Service authorised by the manufacturer. It is recommended that necessary repairs to machine should be undertaken by specialised workshops.
- In the event of any fault or damage whatsoever, do not use the cutting head until the fault has been corrected.
- During work use the proper, close-fitting protective clothing, gloves and appropriate tools. When working on hydraulic systems it is recommended to use oil resistant gloves and protective goggles.
- Any modification to the cutting head frees the manufacturer from any responsibility for damage or detriment to health, which may arise as a result.

- Before undertaking any work on the cutting head disconnect tractor engine and wait until all rotating parts come to a stop.
- Regularly check the technical condition of the safety devices and correct tightening of bolt connections.
- Regularly perform service inspections of machine as recommended by the Manufacturer.
- Do NOT perform service or repair work under raised and unsupported machine.
- Before beginning repair works on hydraulic systems, reduce oil pressure.
- Servicing and repair work should be carried out in line with the general principles of workplace health and safety. In the event of injury, the wound must be immediately cleaned and disinfected. In the event of more serious injuries, seek a doctor's advice.
- Repair, maintenance and cleaning work should be carried out with the tractor's engine turned off and the ignition key removed. Immobilise tractor with parking brake. Ensure that unauthorised persons do not have access to the tractor cab.
- Should it be necessary to change individual parts, use only original parts. Non-adherence to these requirements may put the user and other people's health and life at risk, and also damage the machine and invalidate the warranty.
- Regularly check technical condition and mounting of all guards and protective elements.
- In the event of work requiring the cutting head to be raised, use properly certified hydraulic or mechanical lift jacks for this purpose. After lifting the machine, stable and durable supports must also be used. Do NOT carry out work under the machine, which has only been raised with the multifunction arm.
- The machine must not be supported using fragile elements (bricks or concrete blocks).
- After completing work associated with lubrication, remove excess oil or grease.
- Damaged, missing or worn blades must be replaced in pairs (simultaneously with a blade located on the opposite side of the shaft axis) in order to maintain the balance of the flail shaft.

- In order to reduce the danger of fire the machine must be kept in a clean condition.

2.1.6 CUTTING HEAD OPERATION

- Before lowering or lifting the cutting head mounted on the multifunction arm, make sure there are no bystanders near the machine.
- Before starting cutting head drive, the cutting assembly must be lowered to working position.
- Before starting the cutting head, make sure that there are no bystanders (especially children) or animals in the danger zone. The machine operator is obliged to ensure proper visibility of the machine and the working area.
- Mowing should begin after reaching nominal speed of 1000 rpm of the multifunction arm's PTO (WWP600 / WWP500). Do NOT overload the cutting head.
- During cutting do NOT use PTO revolution speed greater than 1000 rpm (WWP600 / WWP500).
- When mowing on the edges of streets, public roads, on stony ground there is a risk that thrown out stones and foreign bodies may pose a risk to bystanders and other vehicles passing by.
- Do NOT leave the tractor cab, when the machine drive is engaged.
- Do NOT stand within the cutting head's working zone.
- Do NOT approach cutting unit guards until the rotating cutting parts come to a complete standstill.
- Do NOT operate the cutting head while reversing. While reversing lift the machine.
- Keep a safe distance from electric power lines during travel with raised cutting assembly.

2.2 DESCRIPTION OF MINIMAL RISK

Pronar Sp. z o. o. in Narew has made every effort to eliminate the risk of accidents. There is, however, a certain minimal risk, which could lead to an accident, and this is connected mainly with the actions described below:

- using the machine for purposes other than those for which it is intended,
- being between the tractor and the machine while the engine is running and when the machine is being attached,
- being on the machine while the engine is running,
- operating the cutting head with removed or faulty safety guards,
- not maintaining safe distance from the danger zone or being within the zones while the machine is operating,
- operation of the machine by persons under the influence of alcohol,
- cleaning, maintenance and technical checks when the multifunction arm is connected and working.

The minimal risk may be kept to a minimum by following the recommendations below:

- prudent and unhurried operation of the machine,
- sensible application of the remarks and recommendations stated in the Operator's Manual,
- carrying out repair and maintenance work in line with operating safety rules,
- carrying out repair and maintenance work by persons trained to do so,
- using close fitting protective clothing,
- ensuring unauthorised persons have no access to the machine, especially children.
- maintaining safe distance from forbidden or dangerous places
- a ban on being on the machine when it is operating

2.3 INFORMATION AND WARNING DECALS

The cutting head is labelled with the information and warning decals mentioned in table (2.1). The symbols are positioned as presented in figure (2.1). Throughout the time it is in use, the user of the machine is obliged to take care that notices and warning and information symbols located on the machine are clear and legible. In the event of their destruction, they must be replaced with new ones. Safety decals are available from your PRONAR dealer or directly from PRONAR customer service. New assemblies, changed during repair, must be labelled once again with the appropriate safety signs. During cutting head cleaning do not use solvents which may damage the coating of information label stickers and do not subject them to strong water jets.

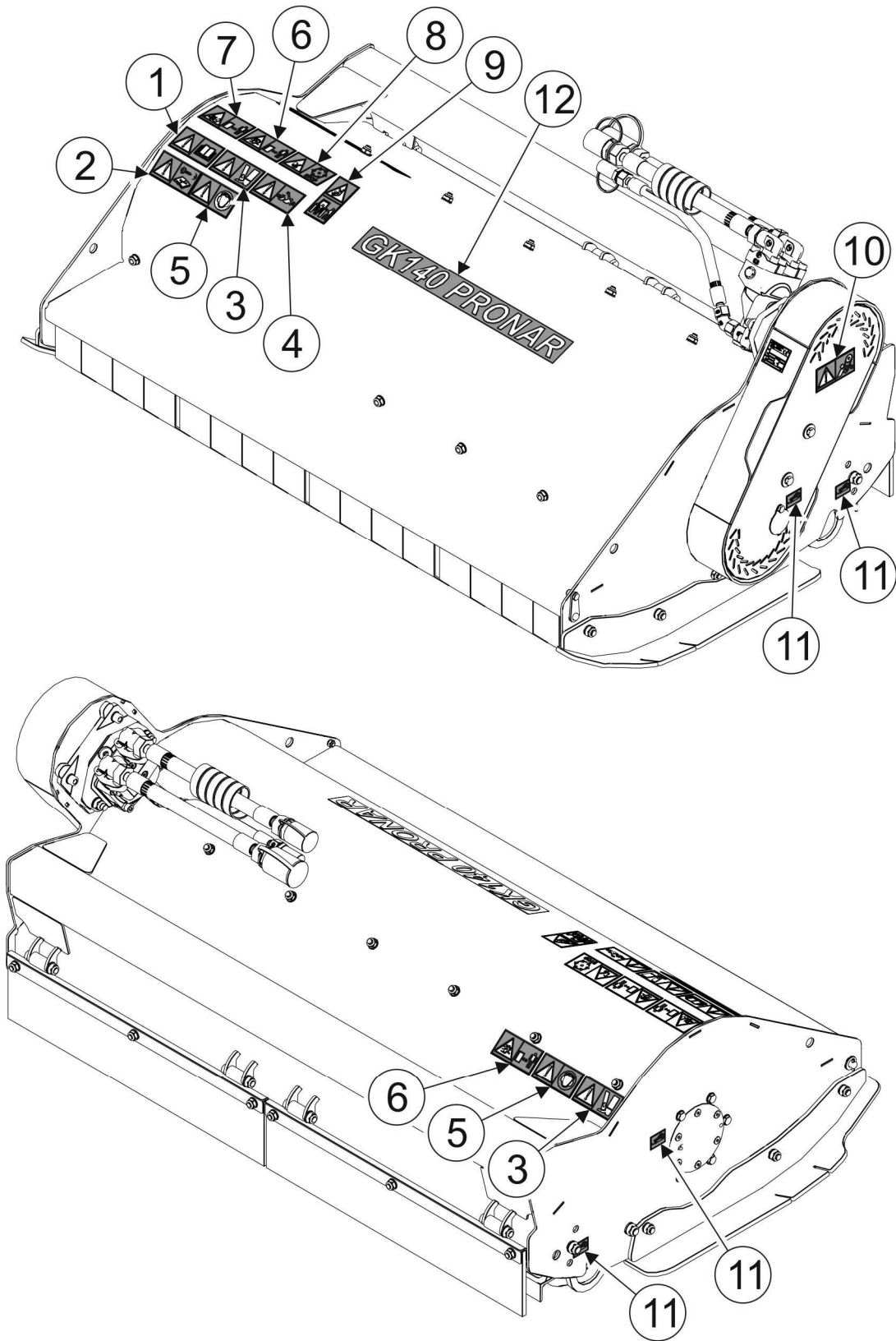

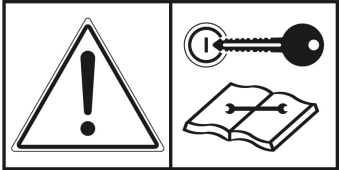



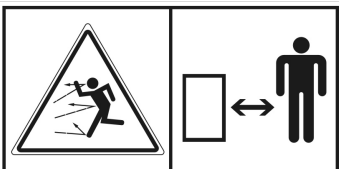
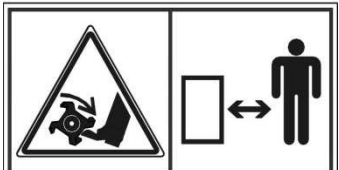
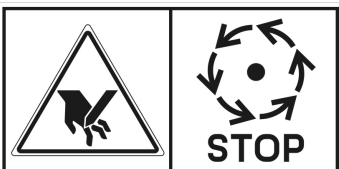





FIG. 2.1 Locations of information and warning decals.

Meaning of symbols (TAB. 2.1)

TAB. 2.1 Information and warning decals

ITEM	DECAL	MEANING
1		Before starting work, carefully read the Operator's Manual.
2		Before beginning servicing or repairs, switch off engine and remove key from ignition
3		Danger of crushing toes or feet.
4		Danger associated with the rotating PTO shaft.
5		High noise level warning.
6		Thrown out objects, endanger the whole body. Keep a safe distance from the operating machine.
7		Risk of injury to foot or leg. Keep a safe distance.
8		Do not touch any rotating elements until they come to a complete standstill.

ITEM	DECAL	MEANING
9		<p>Do not stand directly behind the tractor while operating the rear hitch.</p>
10		<p>Attention! Belt transmission, take extreme care.</p>
11		<p>Lubrication points</p>
12	<p style="text-align: center;">GK110 PRONAR</p> <p style="text-align: center;">or</p> <p style="text-align: center;">GK140 PRONAR</p>	<p>Machine type</p>

Numbers in the item column correspond to decals (FIG. 2.1)

SECTION

3

**DESIGN AND
OPERATION**

3.1 TECHNICAL SPECIFICATION

TABELA 3.1 BASIC TECHNICAL SPECIFICATION

	Unit	GK110	GK140
Dimensions			
Total length in transport setting	mm	920	
Width in transport setting:	mm	1370	1590
Height in transport setting:	mm	625	
Technical specification			
Cutting width	mm	1100	1400
Productivity	ha/h	0,4	0,6
Recommended mowing speed	km/h	4	4
Tare weight	kg	294	318
Maximum PTO speed	RPM	1000	
Linkage:		Multifunction arm WWP600 WWP500 WWP500U	
Flail shaft diameter	mm	Ø133	Ø133
Tracing shaft diameter	mm	Ø133	Ø133
Number of flail blades	item	10	12
Rotation speed of flail shaft	RPM	2550	2550

3.2 GENERAL DESIGN

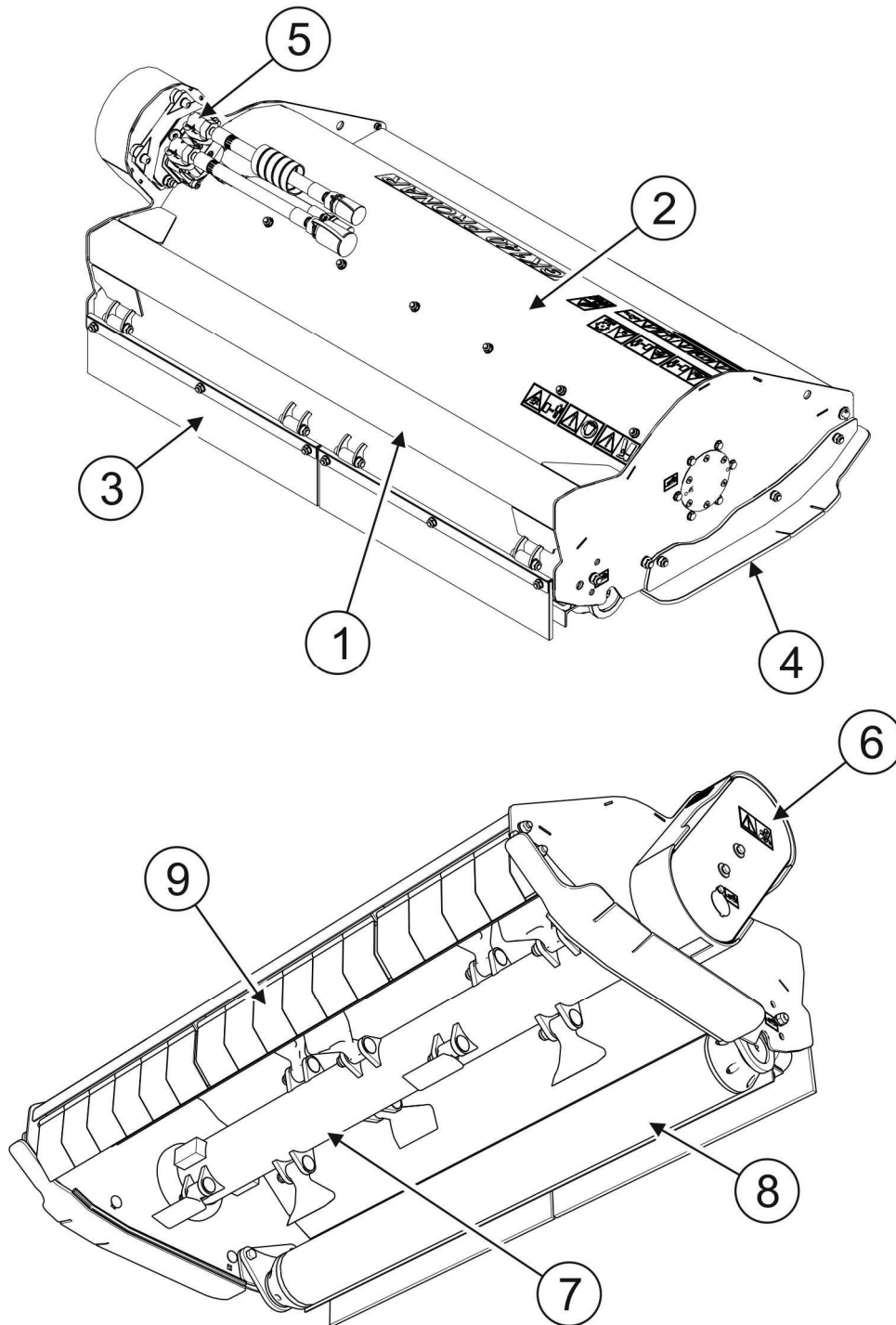

FIG. 3.1 General design

(1)- loadbearing beam; (2)- cutting unit housing; (3)- rubber guard; (4)- slide; (5)- hydraulic motor; (6)- belt transmission;
 (7)- flail shaft; (8)- tracking shaft; (9)- front guard;

The cutting head consists of loadbearing beam (1) that enables connection of the cutting head with the head of multifunction arm WWP600, WWP500 or WWP500U, the drive transmission system composed of hydraulic motor (5) and belt transmission (6) and the cutting unit composed of flail shaft (7) and tracking shaft (8). The complete cutting unit is shielded with housing (2) as well as front guards (9) and rubber guard (3).

3.3 DRIVE TRANSMISSION

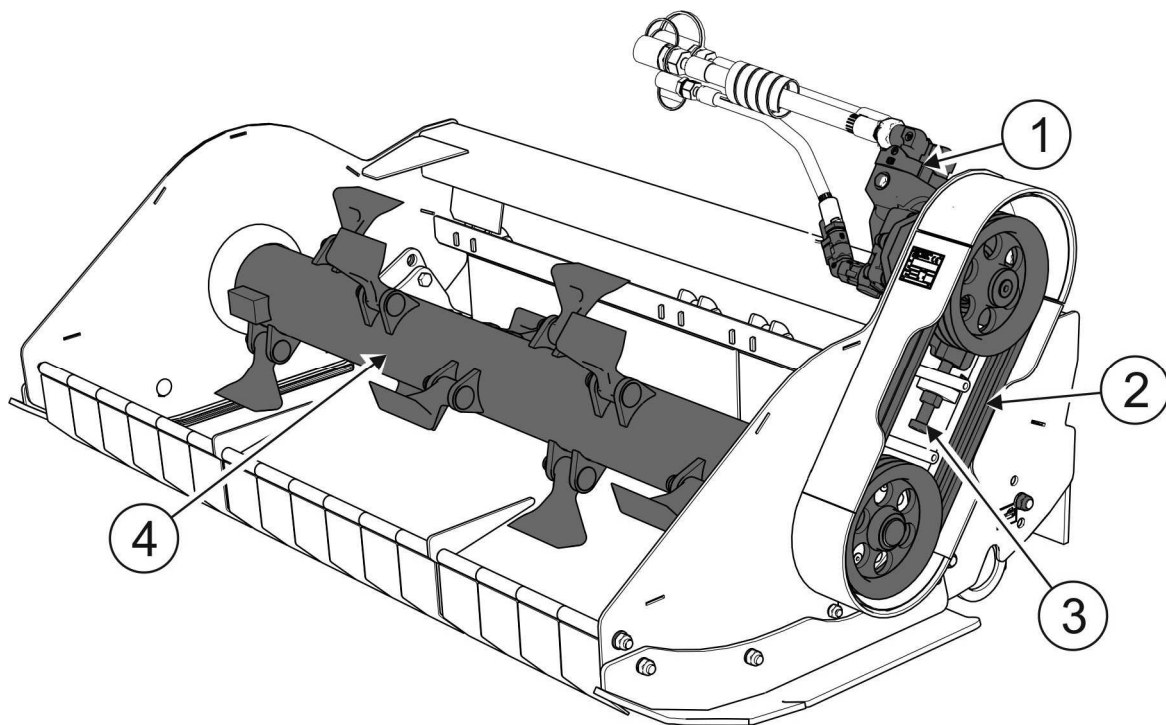

FIG. 3.2 Drive transmission.

(1)- hydraulic motor; (2)- belt transmission; (3)- adjustment bolt; (4)- flail shaft.

The cutting unit of cutting head is driven by hydraulic motor (1) that is supplied by hydraulic conduits running from the multifunction arm. The torque from the hydraulic motor is transmitted to flail shaft (4) by means of belt transmission (2). In this case, the belt transmission performs also the function of overload protection clutch.

3.4 CUTTING UNIT

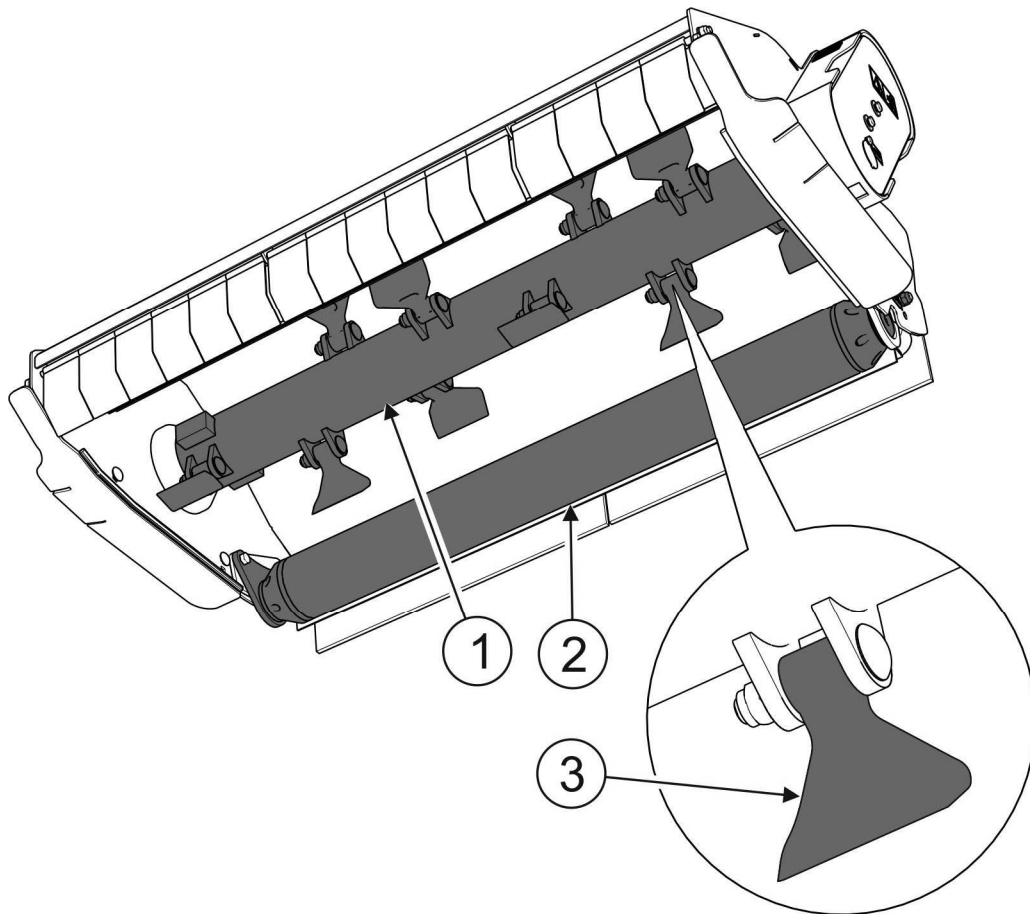

FIG. 3.3 **Cutting unit**

(1)- flail shaft; (2)- tracking shaft; (3)- flail blade.

The cutting unit of cutting head consists of flail shaft (1) on which flail blades are mounted (3). The flail blades are designed to swing and avoid obstacles which can not be cut. Cutting height is adjusted by changing the tracking shaft (2) setting. Flail shaft is mounted on bearings installed in the cutting unit housing.

SECTION

4

CORRECT USE

4.1 PREPARING FOR WORK

The manufacturer guarantees that the machine is fully operational and has been checked according to quality control procedures and is ready for use. This does not release the user from an obligation to check the machine's condition after delivery and before first use. The machine is delivered to the user completely assembled.



ATTENTION!

Before using the cutting head always check its technical condition. In particular check technical condition of cutting unit, drive unit and completeness of safety guards.

Before hitching to the multifunction arm, the machine operator must check the technical condition of the cutting head and prepare it for test start-up. In order to do this:

- the user must carefully read this Operator's Manual and observe all recommendations, understand the design and the principle of machine operation
- check the condition of protective paint coat,
- Inspect machine's individual components for mechanical damage resulting from incorrect transport (dents, piercing, bent or broken components),
- Check all the lubrication points, lubricate the machine according to recommendations provided in section 5 "MAINTENANCE",



ATTENTION!

Before beginning work lubricate flail shaft bearings and tracking shaft bearings until grease appears between the shaft and bearing housing.

- check technical condition of the hydraulic system;
- check if flail blades, cutting shaft, linkage and safety guards are correctly installed.

If all the above checks have been performed and there is no doubt as to the machine's good technical condition, hitch the machine to the multifunction arm. Start the tractor's engine, check all systems and perform a test run before beginning work. In order to inspect:

- hitch the cutting head to the multifunction arm (see „*HITCHING TO MULTIFUNCTION ARM*“)
- set in working position,

- start PTO drive and engage cutting head's drive by means of control panel.

Engage cutting head's drive for 3 minutes and check the following:

- that there is no knocking or noise in the drive system arising from scraping or grinding of metal elements,
- whether there is excessive vibration in the cutting unit,
- synchronised rotation of cutting unit (FIGURE 4.1).

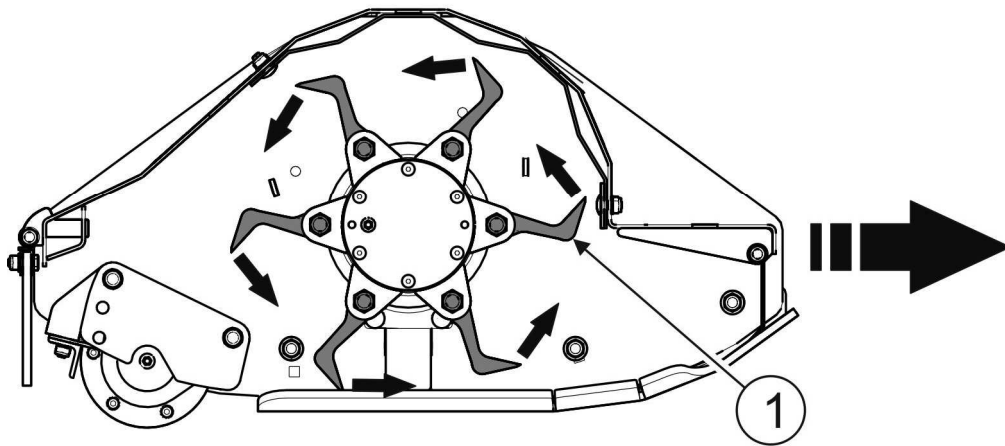

FIG. 4.1 **Rotation of cutting unit synchronised with direction of tractor travel.**

(1)- cutting unit



ATTENTION!

Before using the cutting head always check its technical condition. In particular check the technical condition of the cutting unit, linkage, drive system, and integrity of protective guards.

The cutting head's operation at no load should be smooth. Shaking of drive transmission, cutting unit and whole machine is not acceptable, nor is changed noise and vibrations coming from loose nut and bolt connections. After stopping cutting head, check fastening of flail blades. Confirm that oil does not leak from the hydraulic motor.

DANGER

Before using the cutting head, the user must carefully read this operator's manual.

Careless and improper use and operation of the cutting head, and non-compliance with the recommendations given in this operator's manual is dangerous to your health.

The cutting head must never be used by persons, who are not authorised to drive agricultural tractors, including children and people under the influence of alcohol or other drugs.

Non-compliance with the safety rules of this Operator's Manual can be dangerous to the health and life of the operator and others.

Before starting the cutting head, make sure that there are no bystanders in the danger zone.

If any faults are detected they must be identified and rectified. If a fault cannot be rectified or the repair could void the warranty, please contact retailer for additional clarifications.

4.2 CHECKING TECHNICAL CONDITION

When preparing the cutting head for normal use, check individual elements according to guidelines presented in table (4.1).

TABELA 4.1 TECHNICAL INSPECTION SCHEDULE

DESCRIPTION	SERVICE OPERATION	FREQUENCY
Condition of safety guards	Check technical condition of safety guards, if complete and correctly mounted.	Daily before beginning work
Check if hydraulic conduits and linkage are correctly installed	Check if correctly installed	
Technical condition of flail blades	Visually inspect and if necessary replace according to section „ <i>CHECKING AND REPLACING CUTTING KNIVES</i> ”	
Technical condition of drive system	For details please refer to section “ <i>DRIVE SYSTEM OPERATION</i> ”	
Tightening of all main nut and bolt connections	Torque values should be according to table (5.4)	Every six months
Lubrication	Lubricate elements according to table <i>LUBRICATION</i> .	According to table (5.3)



ATTENTION!

Do NOT use out of order cutting head.

4.3 HITCHING TO MULTIFUNCTION ARM

Cutting head PRONAR GK110 / GK140 can be hitched to multifunction arm WWP600, WWP500 or WWP500U.



ATTENTION!

Before hitching the cutting head, the user must carefully read the operator's manuals of the cutting head, tractor and multifunction arm and observe all instructions contained in the manuals.



DANGER

When hitching, there must be nobody between the machine and the tractor.
Exercise caution when hitching the machine.



DANGER

Before hitching the cutting head, turn off the tractor's engine and remove the key from the ignition. Ensure that unauthorised persons do not have access to the tractor.
Check technical condition of the cutting head's guards and general technical condition of the cutting head.

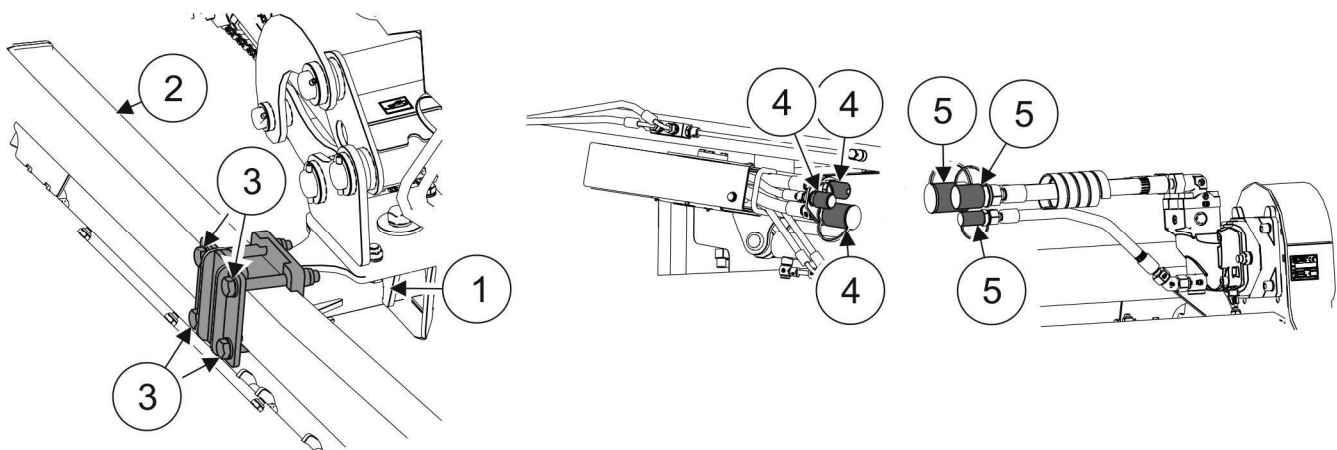

FIG. 4.2 Hitching to multifunction arm

(1)- head of multifunction arm; (2)- loadbearing beam of cutting head; (3)- cutting head fixing bolts; (4)- quick couplers of multifunction arm; (5)- quick couplers of the cutting head's hydraulic conduits.

In order to hitch the cutting head to the multifunction arm head (FIGURE 4.2), proceed as follows:

- Reverse the tractor and bring multifunction arm head (1) close to loadbearing beam (2) of cutting head.
- By means of control panel, set multifunction arm head (1) at the same height with loadbearing beam of cutting head.
- switch off tractor's engine and prevent it from moving.
- Connect multifunction arm head (1) with loadbearing beam of cutting head (2) using four fixing bolts (3).
- Connect quick couplers of the cutting head's hydraulic conduits (5) with quick couplers (4) of multifunction arm.
- Raise cutting head by means of control panel of multifunction arm.



DANGER

Prior to connecting individual hydraulic system conduits, the user must carefully read the operator's manual of the multifunction arm and observe all recommendations of the Manufacturer.



DANGER

When connecting the hydraulic quick couplers to the cutting head, make sure that the hydraulic system of the multifunction arm is not under pressure.

4.4 TRANSPORTING THE MACHINE

For transport to place of work and back, raise the cutting head and mount it on hitch (2) of multifunction arm head (1) (FIGURE 4.3).

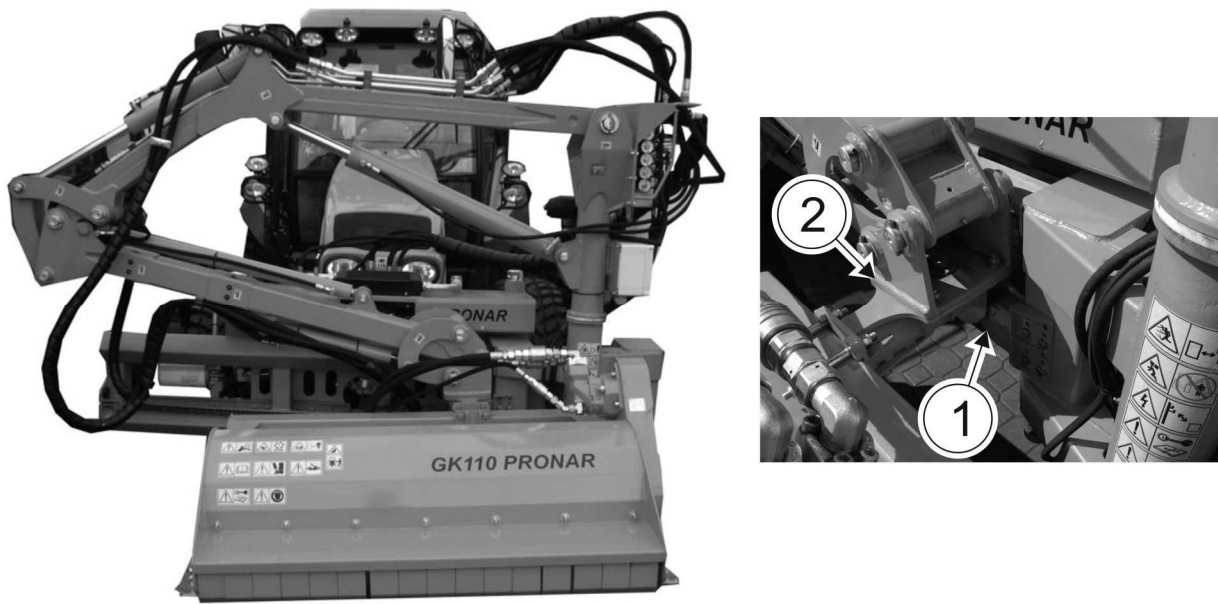

FIG. 4.3 **Transport position**

(1)- hitch of multifunction arm head; (2)- multifunction arm head;

4.5 SETTING AND MOWING

4.5.1 SETTING THE MOWER IN WORKING POSITION

To set the mower in working position:

- raise the cutting head above the hitch of the multifunction arm head
- controlling appropriate hydraulic circuits in the tractor, set the arms of the multifunction arm so as to place the cutting head in the mowing area (FIGURE 4.4)

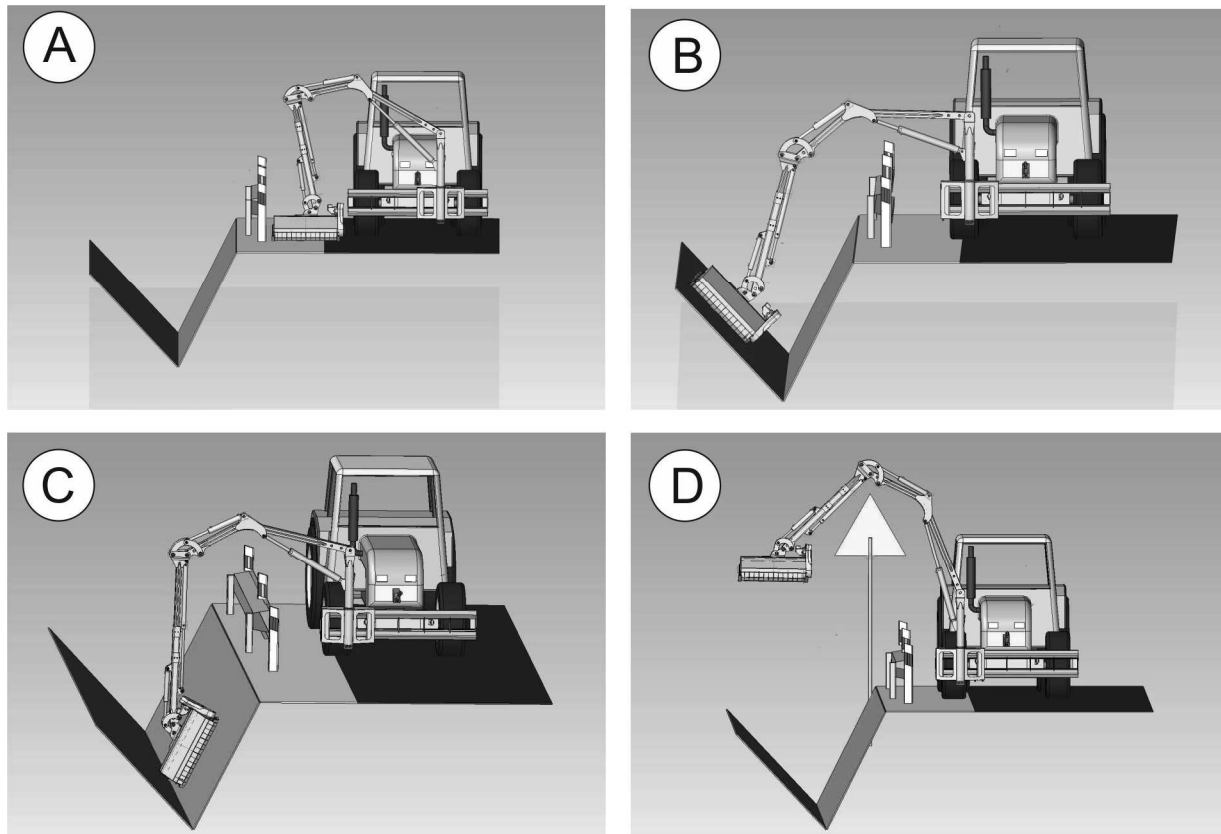

FIG. 4.4 **Setting the cutting head in working position**

(A)- working position for road shoulder mowing; (B)- working position for mowing the opposite slope of roadside ditch; (C)- working position for roadside ditch mowing; (D)- working position for moving the cutting head above a road sign.

- the cutting unit of the cutting head should be supported freely on the ground, on the tracking shaft. Slides should not touch the ground and the complete cutting unit should be set in parallel to the ground (FIGURE 4.5).

4.5.2 SETTING CUTTING HEIGHT

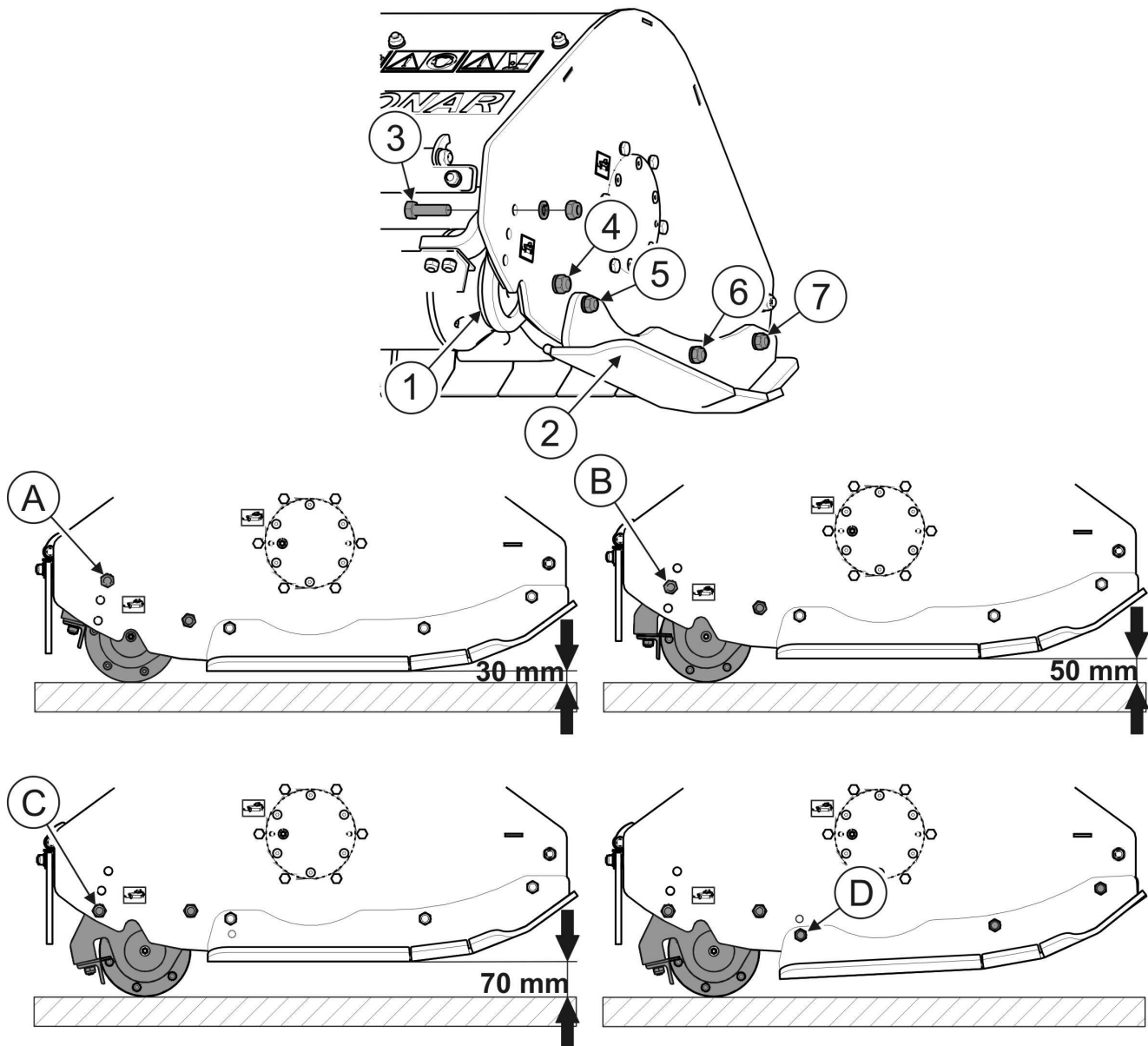

FIG. 4.5 Setting cutting height of the cutting head.

(1)- tracking shaft; (2)- slide; (3)- tracking shaft fixing bolt; (4)- nut; (5)- slide fixing bolt; (6)- nut; (7)- nut; (A)- position of the bolt setting cutting height of 30 mm; (B)- position of the bolt setting cutting height of 50 mm; (C)- position of the bolt setting cutting height of 70 mm; (D)- position of the bolt setting slide angle.

Adjust the multifunction arm in such a way as to ensure that the mower slides are set in parallel to the ground. Cutting height can be modified by changing the tracking shaft (1) position with regard to the mower housing. In order to do this (FIGURE 4.5):

- loosen nuts (4) of bolts on both sides of the tracking shaft (1) on which the tracking shaft will be turned;

- undo nuts and remove fixing bolts (3) on both sides of the tracking shaft
- turn the tracking shaft with bracket so as to ensure that the opening in the bracket aligns with the opening in the side of the mower housing, depending on the cutting height to be achieved: A (30 mm), B (50 mm) or C (70 mm),
- insert fixing bolts (3) into appropriate openings and screw on the nuts;
- tighten nuts (4) of the bolt on which the tracking shaft was turned, on both sides of the tracking shaft.

When changing cutting height to 50 mm or 70 mm, it is recommended to change slides (2) angle simultaneously. Consequently, the tracking shaft rake angle at the moment of collision with obstacle will be reduced. In order to do this:

- loosen nuts (6) and (7) of the bolts securing the slide;
- unscrew nut and take out bolt (5) fixing the slide;
- turn the slide so as to ensure that the slide opening aligns with the lower opening in the side of the cutting head housing (D) (FIGURE 4.5);
- insert fixing bolt (5) into the aligned openings and screw on the nut
- tighten nuts (6) and (7) of the bolts securing the slide.
- Angle of the slide located on the opposite side of the cutting head housing should be also changed.

4.5.3 MOWING



DANGER

The cutting head may only be started when all guards are in place and the cutting unit is set in working position.

Before engaging cutting head drive make sure that there are no bystanders, especially children, near the cutting head.

Other persons should be at a safe distance from the cutting head during work because of the danger that objects may be thrown (stones, branches from beneath rotating disks).

**ATTENTION!**

Before beginning work lubricate flail shaft bearings and tracking shaft bearings until grease appears between the shaft and bearing housing.

After setting the cutting head in working position and adjusting cutting height, the cutting head starting procedure may begin.

**HIGH NOISE LEVEL WARNING**

Depending on the working conditions, the tractor with the machine may generate noise exceeding the level of 85dB at the driver position. In such conditions the driver should apply individual protection (protective ear guards).

In order to reduce the level of noise during work the tractor cab window and door should be closed.

When mowing and chopping pay attention to uneven surface and obstacles in the mown crop. Mowing speed depends on the quantity and quality of mown crop but also on the type of terrain. The maximum recommended mowing speed is 4 km/h.

Mowing speed must be reduced if:

- mown ground is uneven,
- mown and chopped crop is very high and dense,
- there is a great risk of running into foreign bodies e.g. stones, thick branches, steel or concrete objects.

When driving across the road, pavement or other obstacles and when making turns, raise the cutting head by means of the multifunction arm and disengage the cutting head drive.

Be especially careful when mowing along ditches, furrows and slopes. If the drive belts slip in the belt transmission during mowing, disengage the drive and check the cause of the overload. Belt slipping may occur because of too low or excessive rotation speed of the cutting unit.

Do not exceed 1000 rpm of the multifunction arm's PTO (WWP600 / WWP500). Excessive rotation speed of the cutting head's flail shaft does not improve quality of mowing but increases load of hydraulic system which may cause damage to components of hydraulic systems of the multifunction arm or the cutting head.

4.5.4 REMOVING BLOCKAGES

DANGER



If the cutting head drive transmission system or cutting unit is blocked, switch off tractor engine and remove key from ignition. Secure tractor using parking brake and ensure that unauthorised persons, especially children, have no access to the tractor.

In the event of work requiring the cutting head to be raised, after lifting the machine, stable and durable supports must also be used. Do NOT carry out work under the machine, which has only been raised with the multifunction arm.

The machine must not be supported using fragile elements (bricks or concrete blocks).

If the belts slip in the belt transmission during mowing, disengage the drive and check the cause of blockage. If blockage occurs as a result of accumulation of mown crop or wrapping of mown crop around the cutting head's cutting unit or as a result of contact with foreign objects (stones, branches, heaps of soil), remove accumulated crop (using a sharp tool) and check condition of cutting elements and their mounting.

In order to reduce the risk of blockage of cutting elements to minimum, mowing speed must be reduced if:

- mown ground is uneven,
- mown and chopped crop is very high and dense,
- there is a great risk of running into foreign bodies e.g. stones, thick branches, steel or concrete objects.

4.6 UNHITCHING FROM MULTIFUNCTION ARM



DANGER

Reduce pressure prior to disconnecting the hydraulic system.

In order to unhitch the cutting head from the multifunction arm (FIGURE 4.2), proceed as follows:

- lower the cutting head by means of the multifunction arm to rest position, on level surface,

- switch off tractor engine and remove key from ignition,
- reduce residual pressure in the hydraulic system by movement of appropriate lever controlling hydraulic circuit,
- disconnect quick couplers (4) of the multifunction arm's hydraulic system from hydraulic conduits (5) of the cutting head and secure them with stoppers,
- disconnect multifunction arm head (1) from loadbearing beam (2) of the cutting head by unscrewing four bolts (3) that fix the head to the loadbearing beam,

The cutting head unhitched from the multifunction arm should be supported on the tracking shaft.

SECTION

5

MAINTENANCE

5.1 INSPECTION AND DISASSEMBLY OF SAFETY GUARDS

The cutting head may only be used when all the safety guards and other protective elements are technically sound and correctly positioned. Safety guards should protect against stones and other foreign objects thrown from the mower. In the event of loss or destruction of the safety guards, they must be replaced with new ones.



DANGER

Before inspecting or dismantling the guards, switch off the tractor's engine and remove the key from the ignition. Cutting head must rest on the ground. Ensure unauthorised persons, especially children, have no access to the machine.

Method of disassembly of safety guards is shown in FIGURE 5.1.

When disassembling rubber guards (1) unscrew nuts (7) that fix clamping strips (2) and then remove clamping strips (2) and rubber guards (1) from fixing bolts (6).

When disassembling front guard (4) unscrew nuts (7) fixing the rod (5) on which the front guard elements are suspended (1) and then slide the rod out so as to enable removal of a damaged element and replacement with a new one.

Front guards (4) are most exposed to damage due to direct contact with objects located on mown surface. Damaged guards (4) should be straightened or replaced with new ones (they are not covered by the guarantee).

Pay special attention to correct mounting of safety guards. Bolts should be tightened using appropriate tightening torque according to TABLE 5.3. TIGHTENING TORQUE FOR NUT AND BOLT CONNECTIONS.



IMPORTANT!

The cutting head must not be started if safety guards are damaged, incorrectly mounted or unsecured.

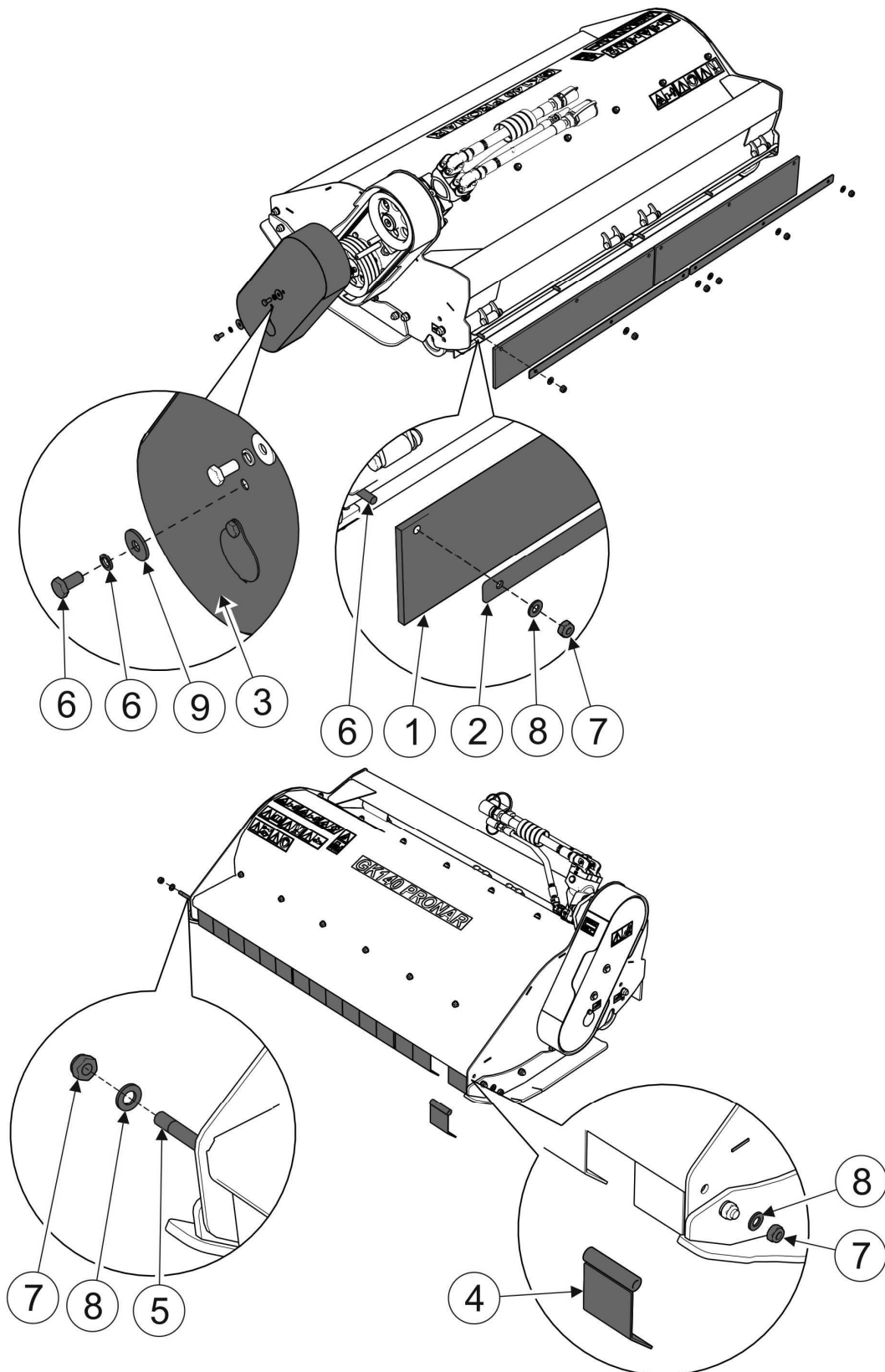

FIG. 5.1 Disassembling safety guards

(1)- rubber guard; (2)- clamping strip; (3)- belt transmission guard; (4)- front guard; (5)- front guard fixing rod; (6)- guard fixing bolt; (7)- nut; (8)- washer; (9)- washer

5.2 CHECKING AND REPLACING FLAIL BLADES



DANGER

Before inspecting or replacing the flail blades, switch off the tractor's engine and remove the key from the ignition. The cutting head must be mounted on the hitch of the multifunction arm's head in transport position and supported on stable and strong supports.

Inspections of flail blades must be carried out regularly. Visual inspection involves checking the blade condition and its mounting. Blades should be worn down uniformly and have the same weight and be of the same type. A bent or damaged blade must be replaced with a new one provided by the mower Manufacturer (Catalogue No.: 18063-RM-4). Flail blades must be replaced in pairs (simultaneously with a blade located on the opposite side of the shaft axis) in order to maintain the balance of the flail shaft. Before proceeding to replace the blades, clean the residue of mown material from the flail shaft.

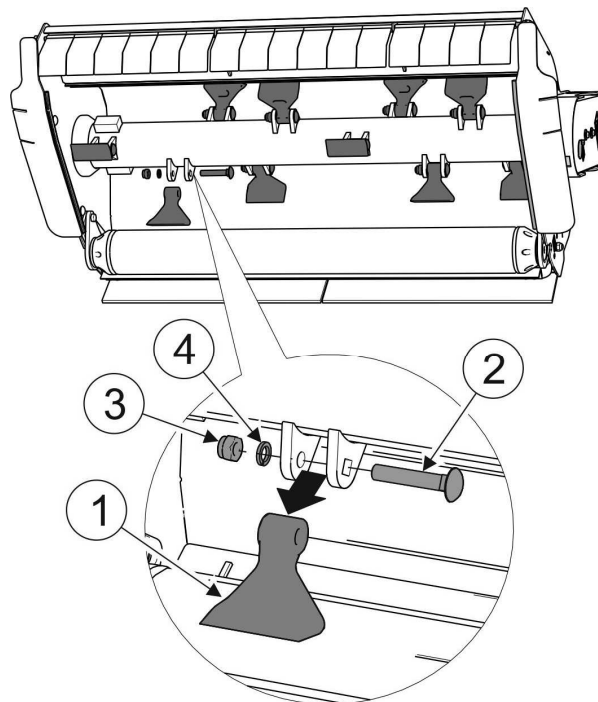

FIG. 5.2 Replacement of cutting knives

(1)- flail blade; (2)- blade fixing bolt; (3)- nut; (4)- spring washer

When replacing blades (1) pay attention to the condition of bolts (2) securing blade to the flail shaft. Excessively worn or damaged bolt must be replaced with a new one of the same strength class (class 10.9). Bolt nut (3) should be tightened so that flail blades can move freely in the lugs of the flail shaft.

**TIP**

Damaged or worn blades must be changed in pairs (simultaneously with a blade located on the opposite side of the shaft axis) in order to maintain the balance of the flail shaft.

**ATTENTION!**

Missing blade or its fragment will cause imbalance and excessive flail shaft vibration and may damage the cutting head.

**DANGER**

Use only the blades provided by the cutting head Manufacturer.

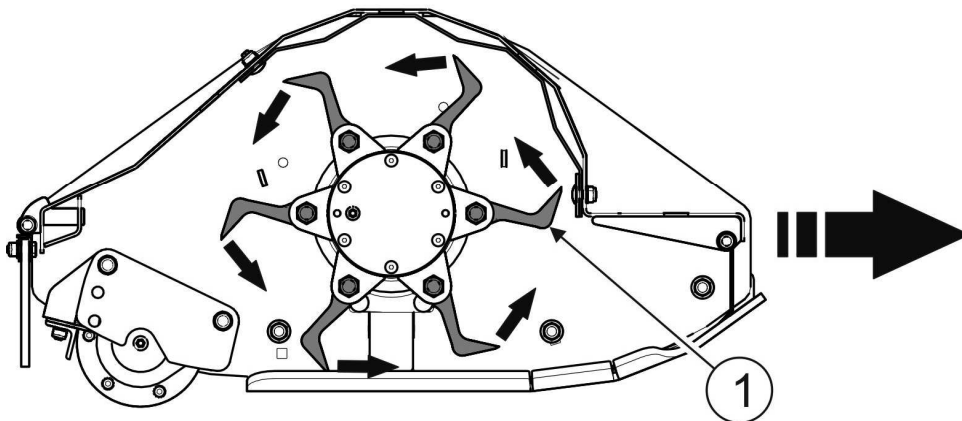

FIG. 5.3 Method of flail blade mounting depending on the rotation direction of the flail shaft and the tractor travel direction.

(1)- flail blades

When replacing blades pay attention to blade mounting with regard to the rotation direction of the flail shaft and the tractor travel direction. Blades should be mounted as shown on FIGURE 5.3.

**ATTENTION!**

Check the technical condition of blades and then mounting on each occasion after driving over obstacle e.g. stone, piece of wood, metal etc.

5.3 DRIVE SYSTEM MAINTENANCE

Drive system maintenance involves periodic inspection, adjustment and possible replacement of vee-belts and inspection of the condition of the hydraulic motor's hydraulic conduits.

Inspection of vee-belts (FIGURE 5.4) involves checking of the belt tension. Deflection of vee-belts measured between transmission's pulleys after application of 10 kG force should not exceed 5 mm. Belts tension may be altered using screw (3) of tensioner. In order to adjust tension of vee-belts, loosen securing nut (2) and bolts (4) that fix the hydraulic motor bracket. After adjustment of belt tension by means of bolt (3), tighten nut (2) and bolts (4) that fix the hydraulic motor bracket. If one of the belts is damaged the whole belt set should be changed. There are 4 SPA-1257 belts in the drive transmission system. To replace the vee-belts, loosen bolts (4) that fix the hydraulic motor bracket and shift the hydraulic motor together with the pulley downwards by means of adjustment bolt (3) until the vee-belts can be removed from the pulley.

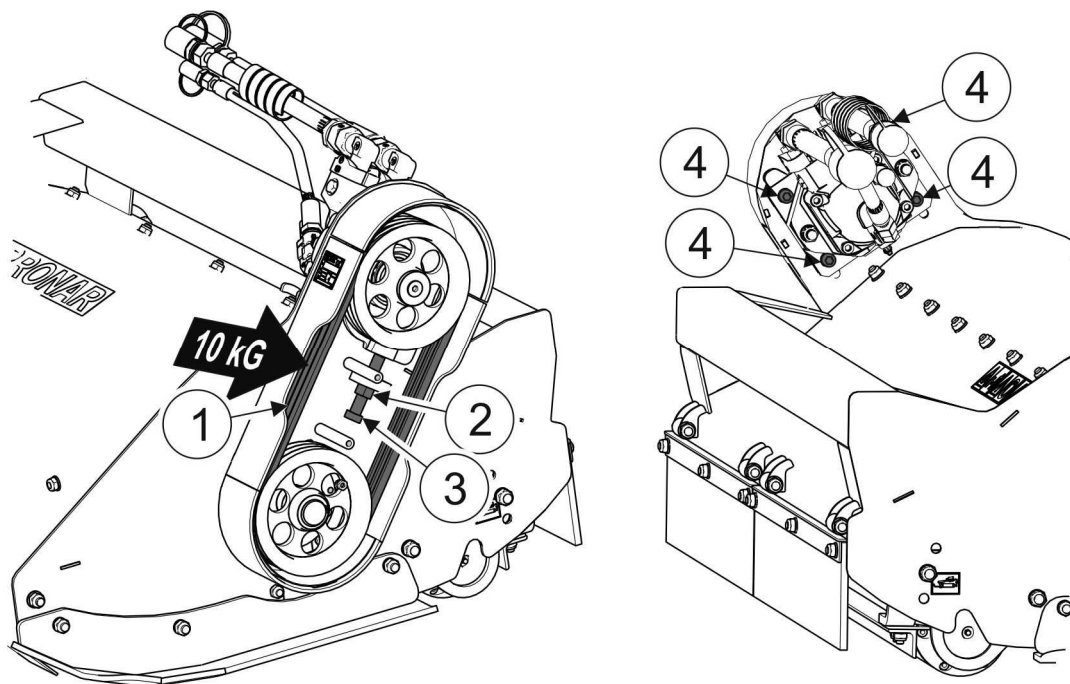

FIG. 5.4 Checking and adjusting tension of vee-belts

(1)- vee-belts; (2)- securing nut; (3)- adjustment bolt; (4)- bolts of hydraulic motor bracket.

ATTENTION!

Excessive tension of vee-belts may eliminate belt slip when the cutting unit is blocked. In such a situation, components of the hydraulic systems of the multifunction arm or the cutting head may get damaged. Excessively tensioned vee-belts apply excessive load to flail shaft bearings and hydraulic motor bearings, which may cause their premature wear.

**DANGER**

Do NOT perform service or repair work under raised and unsupported machine.



Connections of hydraulic conduits supplying hydraulic motor should be checked daily.

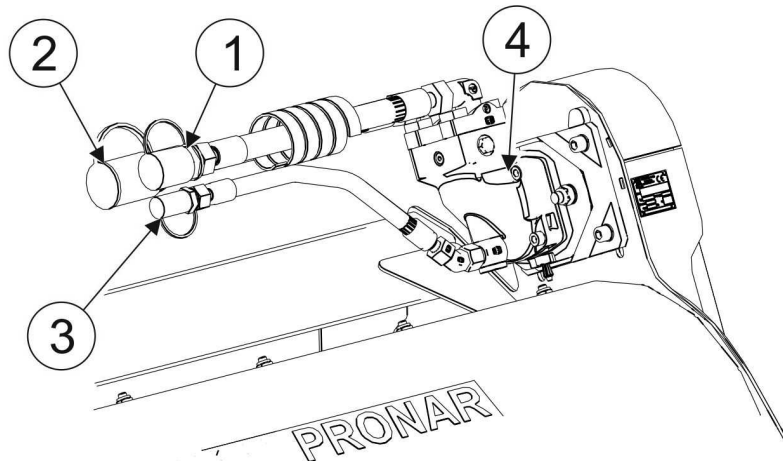

FIG. 5.5 Inspecting connections of quick couplers of hydraulic motor's hydraulic conduits.

(1)- quick coupler; (2)- quick coupler; (3)- quick coupler; (4)- hydraulic motor.

5.4 STORAGE

After completion of work the cutting head should be carefully cleaned and washed with a water jet. While washing do not direct a strong water or steam jet at information and warning decals, bearings or hydraulic lines. Nozzle of pressure or steam washer should be kept at a distance of not less than 30 cm from cleaned surface.

After cleaning, inspect the whole machine, inspect technical condition of individual elements. Used or damaged elements should be repaired or replaced.

In the event of damage to the paint coat, clean rust and dust from damaged area, degrease and then paint with undercoat and after it is dry paint with surface coat paint retaining colour uniformity and even thickness of protective coating. Until the time of touch-up painting, the damaged place may be covered with a thin layer of grease or anticorrosion preparation. Cutting head should be kept in closed or roofed building.

If the cutting head shall not be used for a long period of time, protect it against adverse weather conditions. Lubricate the cutting head according to the instructions provided. In the event of prolonged work stoppage, it is essential to lubricate all elements regardless of the period of the last lubrication process.

5.5 LUBRICATION

Machine lubrication should be performed with the aid of a manually or foot operated grease gun, filled with generally available permanent grease. Before commencing lubrication insofar as is possible remove old grease and other contamination. Remove and wipe off excess oil or grease



When using the machine the user is obliged to observe lubrication instructions according to attached schedule. Excess lubrication substance causes depositing additional contaminants in places requiring lubrication, therefore it is essential to keep individual machine elements clean.

Lubrication points are shown in figure 5.6 and detailed in Table 5.1.

TABLE 5.1 LUBRICATION POINTS

ITEM	NAME	NUMBER OF LUBRICATION POINTS	TYPE OF GREASE	LUBRICATION FREQUENCY
1	Flail shaft bearing	2	grease	daily
2	Tracking shaft bearing	2	grease	daily

Marking description in Item column (TABLE 5.1) conforms with numbering shown on (FIGURE 5.6)

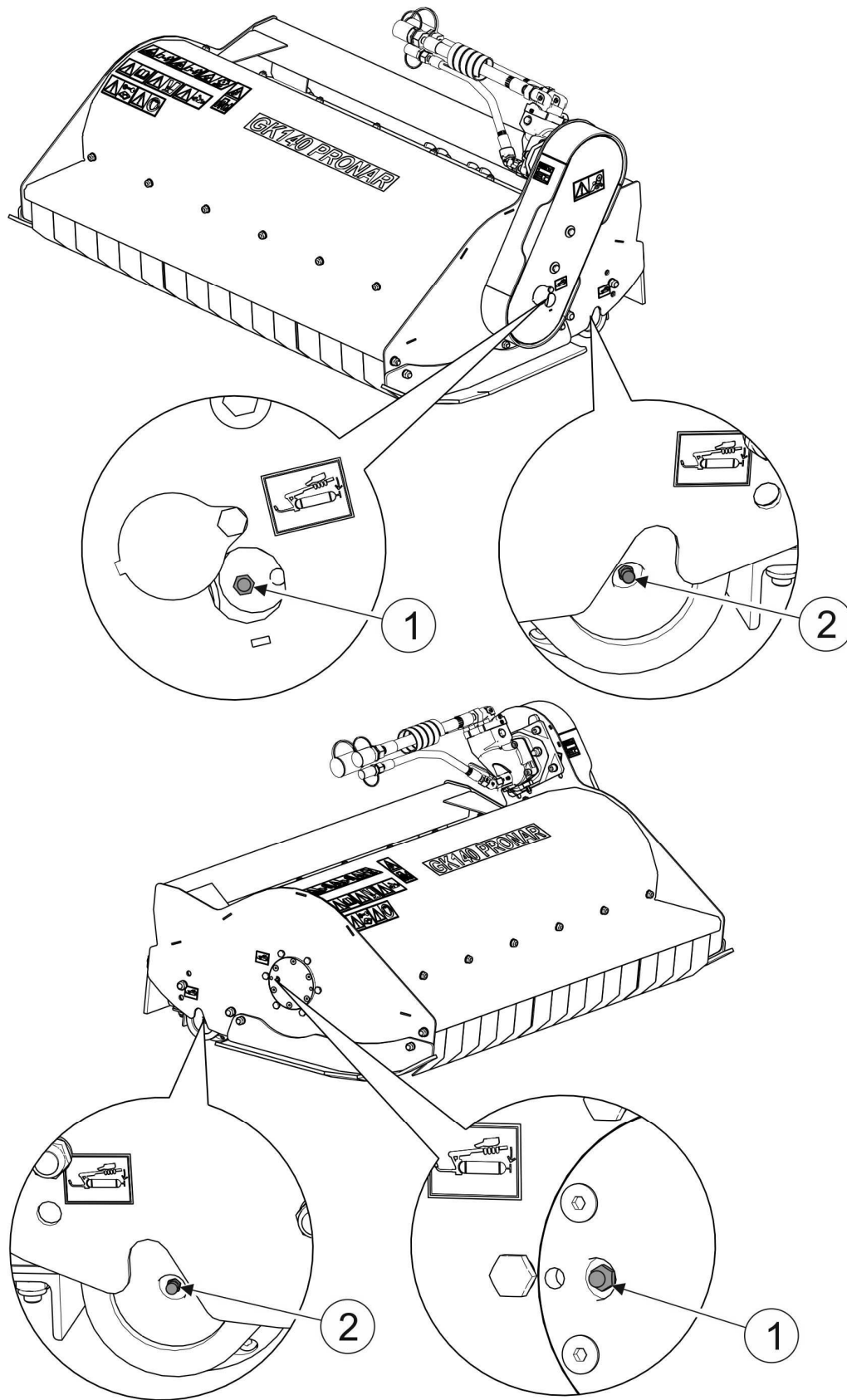

FIG. 5.6 Lubrication points
Lubrication points described in table 5.2

5.6 TIGHTENING TORQUE FOR NUT AND BOLT CONNECTIONS

Unless other tightening parameters are given, during maintenance repair work apply appropriate torque to tightening nut and bolt connections. Recommended torque values apply to non-greased steel bolts.



ATTENTION!

Should it be necessary to change individual parts, use only original parts or those indicated by the Manufacturer. Non-adherence to these requirements may put the user and other people's health and life at risk, and also damage the machine.

TABLE 5.2 TIGHTENING TORQUE FOR NUT AND BOLT CONNECTIONS

THREAD DIAMETER [mm]	5.8	8.8	10.9
	TIGHTENING TORQUE [Nm]		
M6	8	10	15
M8	18	25	36
M10	37	49	72
M12	64	85	125
M14	100	135	200
M16	160	210	310
M20	300	425	610
M24	530	730	1 050
M27	820	1,150	1,650
M30	1050	1 450	2 100
M32	1050	1 450	2 100

5.7 TROUBLESHOOTING

TABLE 5.3 TROUBLESHOOTING

TYPE OF FAULT	CAUSE	REMEDY
It is impossible to start the cutting head drive	Incorrectly connected or damaged quick couplers of the multifunction arm	Check quick couplers and manner of their connection
	Hydraulic system of multifunction arm is out of order	Check condition of the multifunction arm's hydraulic system
It is impossible to set the cutting head by means of the multifunction arm	The tractor's hydraulic system is out of order	Check condition of the multifunction arm's hydraulic system
Excessive vibration during work	Damaged or missing flail blade	Check flail blades, if necessary replace
	Damaged bearings of the flail shaft	Repair at authorised service point
Cutting head drive stops during mowing	Belt slip on belt drive transmission	Disconnect power from mower; remove collected grass or foreign body from cutting unit. Check condition and tension of belts.
	The multifunction arm's hydraulic system or the cutting head's hydraulic motor is out of order	Repair at authorised service point

NOTES

A series of horizontal dotted lines for writing notes.



